



IITK bmtpc

Earthquake Tips

Learning

Earthquake Design

and

Construction



Department of Civil Engineering
Indian Institute of Technology Kanpur
Kanpur

Building Materials & Technology Promotion Council
Ministry of Housing & Urban Poverty Alleviation
Government of India
New Delhi

AUGUST, 2015

IITK BIMTEC

Earthquake Tips

Learning

Earthquake Design

and

Construction

Department of Civil Engineering
Indian Institute of Technology Kanpur
Kanpur

Building Materials & Technology Promotion Council
Ministry of Housing & Urban Poverty Alleviation
Government of India
New Delhi

AUGUST, 2015

ISBN : 978-81-928379-1-8

August, 2015

Published by:

Building Materials & Technology Promotion Council,
Ministry of Housing & Urban Poverty Alleviation, Govt. of India
Core-5A, First Floor, India Habitat Centre,
Lodhi Road, New Delhi - 110 003

Phones: +91-11-2463 6705, 2463 8096;

Fax: +91-11-2464 2849

E-mail: bmtpc@del2.vsnl.net.in

Website: www.bmtpc.org

Price: Rs.200/-

PREFACE

Recurrent earthquakes in Indian sub-continent have been causing loss to properties and lives of people at regular intervals. The Latur earthquake in 1993, Jabalpur earthquake in 1997, Chamoli earthquake in 1999, Bhuj earthquake in 2001, Kashmir earthquake in 2005, Sikkim earthquake in 2011, Doda earthquake in 2012, and most recently Nepal Earthquake in 2015, have clearly demonstrated the earthquake vulnerability profile of our country. Even though at national level, the Government is conscious and has initiated proactive pre-disaster mitigation measures, its implementation at ground level is only possible, if general awareness is created among professionals associated with construction activities, as well as the non-professionals, who are directly and indirectly affected, on earthquake occurrences, their unpredictability, their effect on different types of buildings and measures required to be taken to make buildings safe.

Keeping the above in view, the Indian Institute of Technology Kanpur (IITK) and the Building Materials & Technology Promotion Council (BMTPC), a constituent of Ministry of Housing and Urban Poverty Alleviation, Gol (erstwhile Ministry of Urban Employment & Poverty Alleviation) launched the IITK-BMTPC series of Earthquake Tips in early 2002. Professor C.V.R. Murty was entrusted to take up the daunting task of expressing the concepts in very simple language for the benefit of readers ranging from school kids, non-professionals to professionals.

In the 1st Phase of this exercise, 24 Tips, covering general concept of earthquake occurrences and its measurement, its effect on masonry and RCC buildings, concept of earthquake resistant design and construction; importance of Indian Standard Codes on earthquake resistant structures and advanced techniques to reduce the damaging effect of earthquake, were published. Utmost care was taken to ensure that despite complexity of the concepts, the Tips are simple to comprehend and unambiguous. To ensure the highest quality of technical contents, each Tip is carefully reviewed by two or more experts both within and outside India and their feedback is incorporated before finalizing the Tips.

Seeing the interest of readers in the Tips and considering the potential of creating awareness through the Tips, it was decided to extend it further by adding 8 more Tips, covering features of confined masonry, importance of quality control, earthquake resistant foundation, protection of non-structural elements, liquefaction of soils, importance of loads paths in buildings. This 2nd Phase version of the publication contains all the 32 Tips brought out so far. We hope this volume will be useful in understanding the basics of earthquakes, it's effect on buildings and various aspect of earthquakes resistant design and construction of buildings in the most simplest manner. It is hoped that these Tips may also serve as reference book on earthquake engineering education, and go a long way in BMTPC's effort to make India, an earthquake resilient society.

To have wider outreach, the Tips were released for publication to all interested journals, magazines and newspapers also. Further, the Tips were placed at the website of the National Informal Centre of Earthquake Engineering (NICEE) (www.nicee.org) and Building Materials & Technology Promotion Council (BMTPC) (www.bmtpc.org). The project has succeeded way beyond our expectations. A large number of journals of architects, construction and structural engineering and many prestigious newspapers have published some or all the Tips. NICEE organizes regular quiz programme of School Children on the earthquake tips.

We are grateful to Professor C.V.R. Murty (IIT Madras; currently at IIT Jodhpur) and Professor Sudhir K. Jain (IIT Kanpur; currently in IIT Gandhinagar) for their efforts and dedication, inspite of their added responsibility of running their respective Institutes, to work on the additional Tips. We also take this opportunity to thank numerous reviewers who have willingly spent time in reviewing the Tips. A complete list of reviewers is available at the NICEE website, but a special mention may made here of Ms. Alpa Sheth of Mumbai and Dr. Svetlana Nikolic-Brzev of Vancouver (Canada), who have reviewed these Tips. Finally, we thank numerous newspapers, journals and magazines, who came forward to publish these Tips, at times making an exception of their editorial policy or exclusivity.

Also, we welcome comments and suggestions which can be emailed to nicee@iitk.ac.in or to bmtpc@del2.vsnl.net.in, so as to improve it further.

Dr. Shailesh Kr.Agrawal
Executive Director
Building Materials & Technology Promotion Council
New Delhi

CONTENTS

Preface

Seismic Map of India

Seismic Zones based on Bureau of Indian Standards

[IS:1893 (Part-1)-2002] and Base Map as per digitised data of Survey of India

- Earthquake Tip No. 1 : What Causes Earthquakes?
- Earthquake Tip No. 2 : How the Ground Shakes?
- Earthquake Tip No. 3 : What are Magnitude and Intensity?
- Earthquake Tip No. 4 : Where are Seismic Zones in India?
- Earthquake Tip No. 5 : What are the Seismic Effects on Structures?
- Earthquake Tip No. 6 : How Architectural Features Affect Buildings During Earthquakes?
- Earthquake Tip No. 7 : How Buildings Twist During Earthquakes?
- Earthquake Tip No. 8 : What is the Seismic Design Philosophy for Buildings?
- Earthquake Tip No. 9 : How to Make Buildings Ductile for Good Seismic Performance?
- Earthquake Tip No.10 : How Flexibility of Buildings Affects their Earthquake Response?
- Earthquake Tip No.11 : What are the Indian Seismic Codes?
- Earthquake Tip No.12 : How Do Brick Masonry Houses Behave During Earthquakes?
- Earthquake Tip No.13 : Why should Masonry Buildings have Simple Structural Configuration?
- Earthquake Tip No.14 : Why are Horizontal Bands Necessary in Masonry Buildings?
- Earthquake Tip No.15 : Why is Vertical Reinforcement Required in Masonry Buildings?
- Earthquake Tip No.16 : How to Make Stone Masonry Buildings Earthquake Resistant?
- Earthquake Tip No.17 : How do Earthquakes Affect Reinforced Concrete Buildings?
- Earthquake Tip No.18 : How do Beams in RC Buildings Resist Earthquakes?
- Earthquake Tip No.19 : How do Columns in RC Buildings Resist Earthquakes?
- Earthquake Tip No.20 : How do Beam-Column Joints in RC Buildings Resist Earthquakes?
- Earthquake Tip No.21 : Why are Open-Ground Storey Buildings Vulnerable in Earthquakes?
- Earthquake Tip No.22 : Why are Short Columns more Damaged During Earthquakes?
- Earthquake Tip No.23 : Why are Buildings with Shear Walls Preferred in Seismic Regions?
- Earthquake Tip No.24 : How to Reduce Earthquake Effects on Buildings?
- Earthquake Tip No.25 : Why are Load Paths Important in Buildings?
- Earthquake Tip No.26 : What Harms Load Paths in Buildings?
- Earthquake Tip No.27 : How can Non-structural Elements be protected against Earthquakes?
- Earthquake Tip No.28 : What is a Confined Masonry Construction?
- Earthquake Tip No.29 : What are the Essential Features of Confined Masonry Houses?
- Earthquake Tip No.30 : What is Important in Foundations of Earthquake-Resistant Buildings?
- Earthquake Tip No.31 : Why do Buildings Sink into the Ground during Earthquakes?
- Earthquake Tip No.32 : Why is Quality critical in Earthquake-Resistant Buildings?

India Seismic Zones

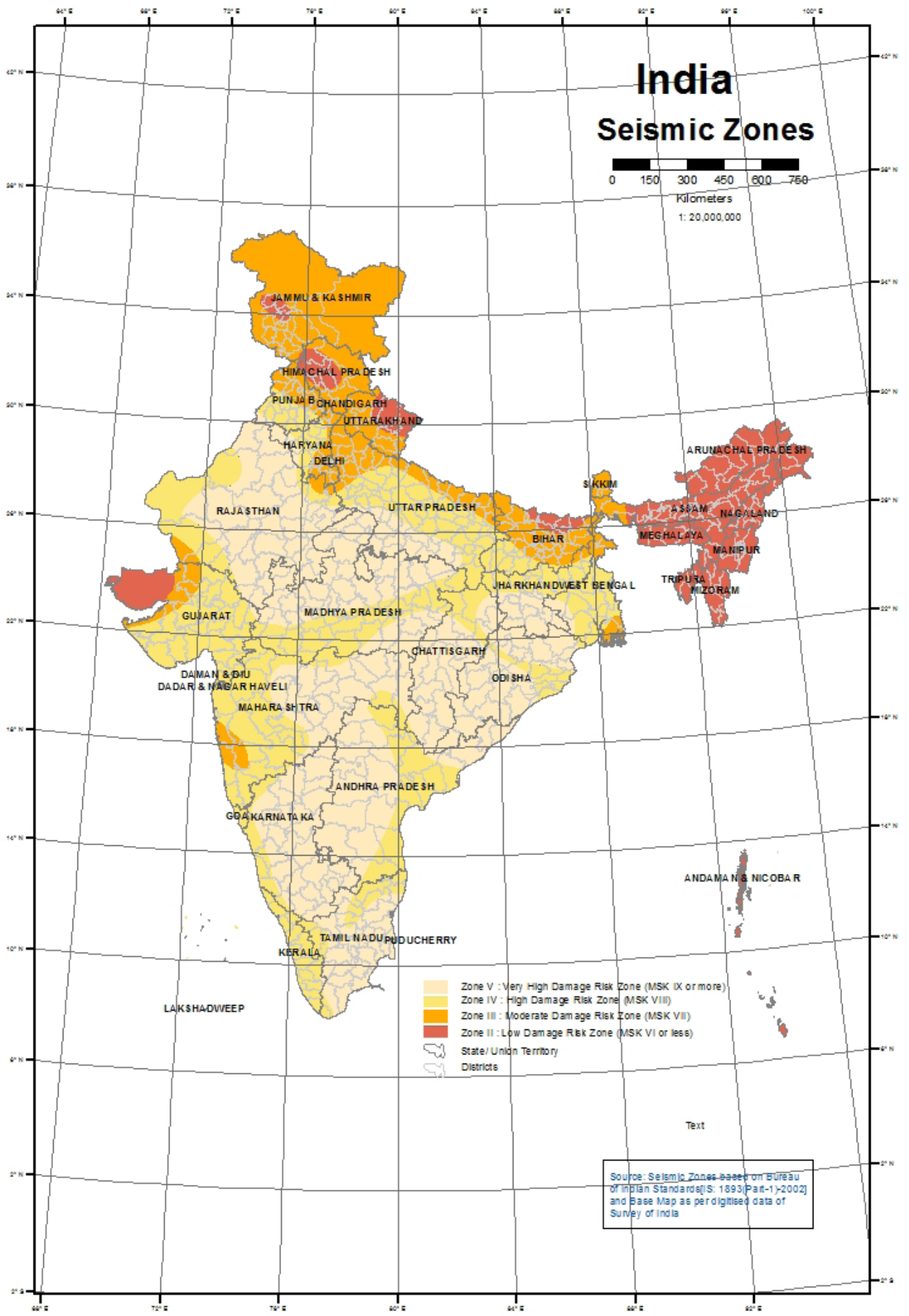
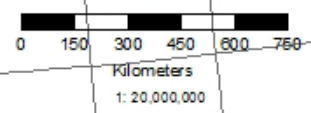

- Zone V : Very High Damage Risk Zone (MSK IX or more)
- Zone IV : High Damage Risk Zone (MSK VIII)
- Zone III : Moderate Damage Risk Zone (MSK VII)
- Zone II : Low Damage Risk Zone (MSK VI or less)
- State/Union Territory
- Districts

Source: Seismic Zones based on Bureau of Indian Standards (IS: 1893 Part-1-2002) and Base Map as per digitised data of Survey of India

What Causes Earthquakes?

The Earth and its Interior

Long time ago, a large collection of material masses coalesced to form the Earth. Large amount of heat was generated by this fusion, and slowly as the Earth cooled down, the heavier and denser materials sank to the center and the lighter ones rose to the top. The differentiated Earth consists of the *Inner Core* (radius $\sim 1290\text{km}$), the *Outer Core* (thickness $\sim 2200\text{km}$), the *Mantle* (thickness $\sim 2900\text{km}$) and the *Crust* (thickness ~ 5 to 40km). Figure 1 shows these layers. The Inner Core is solid and consists of heavy metals (e.g., nickel and iron), while the Crust consists of light materials (e.g., basalts and granites). The Outer Core is liquid in form and the Mantle has the ability to flow. At the Core, the temperature is estimated to be $\sim 2500^\circ\text{C}$, the pressure ~ 4 million *atmospheres* and density $\sim 13.5\text{ gm/cc}$; this is in contrast to $\sim 25^\circ\text{C}$, 1 *atmosphere* and 1.5 gm/cc on the surface of the Earth.

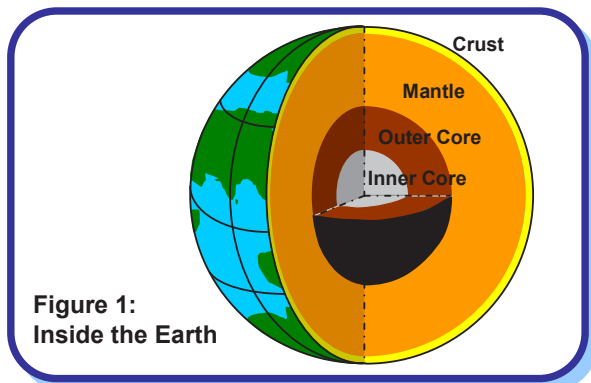

Figure 1:
Inside the Earth

The Circulations

Convection currents develop in the viscous Mantle, because of prevailing high temperature and pressure gradients between the Crust and the Core, like the convective flow of water when heated in a beaker (Figure 2). The energy for the above circulations is derived from the heat produced from the incessant decay of radioactive elements in the rocks throughout the Earth's interior. These convection currents result in a *circulation* of the earth's mass; hot molten lava comes out and the cold rock mass goes into the Earth. The mass absorbed eventually melts under high temperature and pressure and becomes a part of the Mantle, only to come out again from another location, someday. Many such local circulations are taking place at different regions underneath the Earth's surface, leading to different portions of the Earth undergoing different directions of movements along the surface.

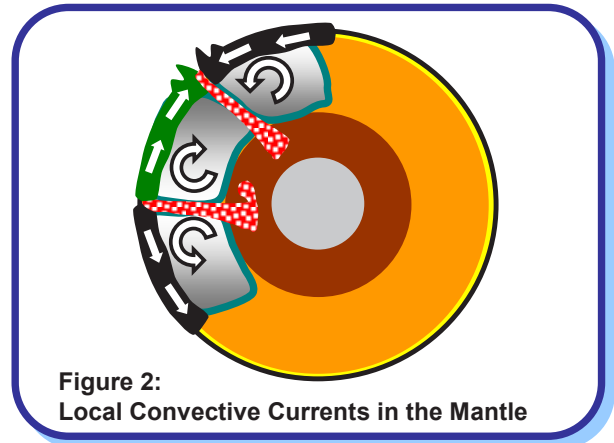

Figure 2:
Local Convective Currents in the Mantle

Plate Tectonics

The convective flows of Mantle material cause the Crust and some portion of the Mantle, to slide on the hot molten outer core. This sliding of Earth's mass takes place in pieces called *Tectonic Plates*. The surface of the Earth consists of seven major tectonic plates and many smaller ones (Figure 3). These plates move in different directions and at different speeds from those of the neighbouring ones. Sometimes, the plate in the front is slower; then, the plate behind it comes and collides (and *mountains* are formed). On the other hand, sometimes two plates move away from one another (and *rifts* are created). In another case, two plates move side-by-side, along the same direction or in opposite directions. These three types of inter-plate interactions are the *convergent*, *divergent* and *transform* boundaries (Figure 4), respectively. The convergent boundary has a peculiarity (like at the Himalayas) that sometimes neither of the colliding plates wants to sink. The relative movement of these plate boundaries varies across the Earth; on an average, it is of the order of a couple to tens of *centimeters per year*.

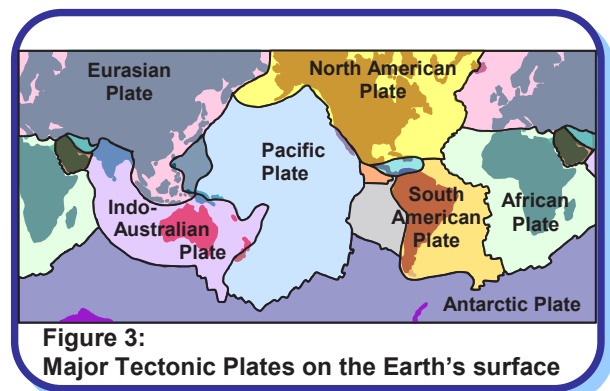

Figure 3:
Major Tectonic Plates on the Earth's surface

What Causes Earthquakes?

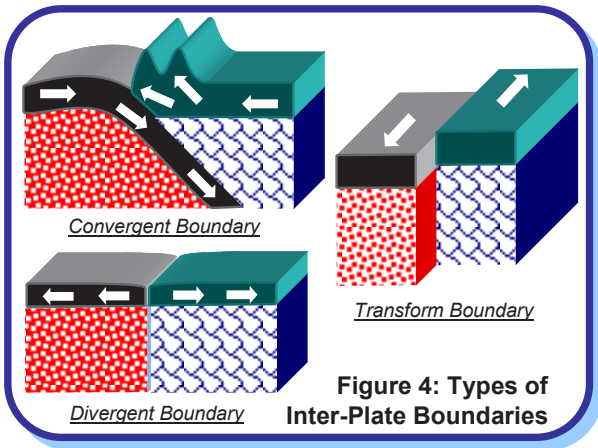

Figure 4: Types of Inter-Plate Boundaries

The Earthquake

Rocks are made of elastic material, and so elastic strain energy is stored in them during the deformations that occur due to the gigantic tectonic plate actions that occur in the Earth. But, the material contained in rocks is also very brittle. Thus, when the rocks along a weak region in the Earth's Crust reach their strength, a sudden movement takes place there (Figure 5); opposite sides of the *fault* (a crack in the rocks where movement has taken place) suddenly *slip* and release the large elastic strain energy stored in the interface rocks. For example, the energy released during the 2001 Bhuj (India) earthquake is about 400 times (or more) that released by the 1945 Atom Bomb dropped on Hiroshima!!

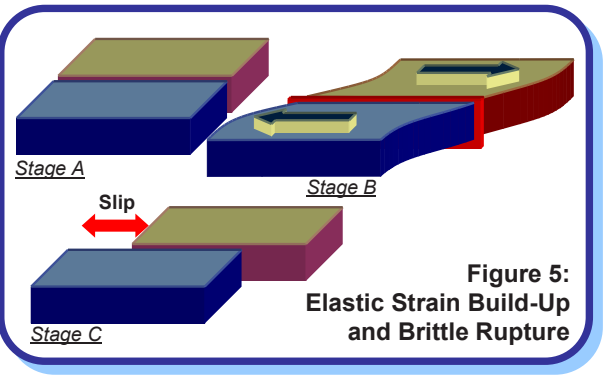

Figure 5: Elastic Strain Build-Up and Brittle Rupture

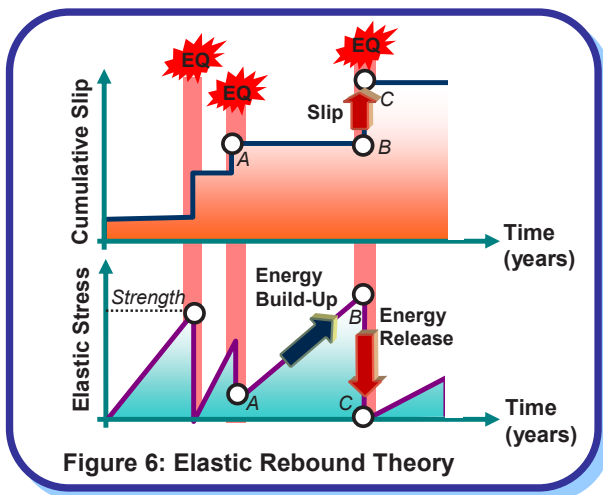

Figure 6: Elastic Rebound Theory

The sudden slip at the fault causes *the earthquake*... a violent shaking of the Earth when large elastic strain energy released spreads out through seismic waves that travel through the body and along the surface of the Earth. And, after the earthquake is over, the process of strain build-up at this modified interface between the rocks starts all over again (Figure 6). Earth scientists know this as the *Elastic Rebound Theory*. The material points at the fault over which slip occurs usually constitute an oblong three-dimensional volume, with its long dimension often running into tens of kilometers.

Types of Earthquakes and Faults

Most earthquakes in the world occur along the boundaries of the tectonic plates and are called *Inter-plate Earthquakes* (e.g., 1897 Assam (India) earthquake). A number of earthquakes also occur within the plate itself away from the plate boundaries (e.g., 1993 Latur (India) earthquake); these are called *Intra-plate Earthquakes*. In both types of earthquakes, the slip generated at the fault during earthquakes is along both vertical and horizontal directions (called *Dip Slip*) and lateral directions (called *Strike Slip*) (Figure 7), with one of them dominating sometimes.

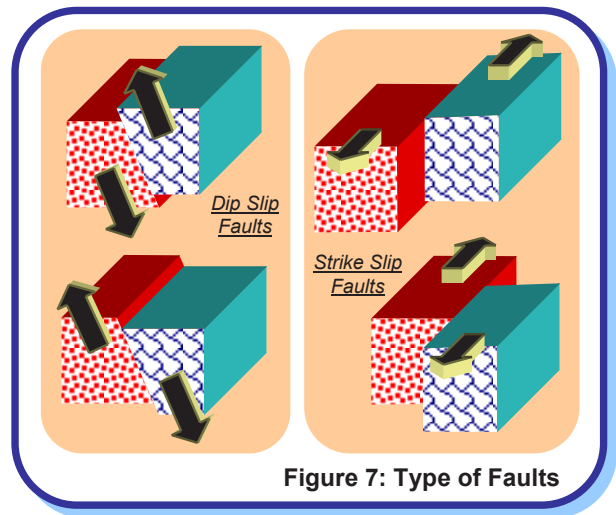

Figure 7: Type of Faults

Reading Material

- Bolt, B.A., (1999), *Earthquakes*, Fourth Edition, W. H. Freeman and Company, New York, USA
- <http://earthquake.usgs.gov/faq/>
- http://neic.usgs.gov/neis/general/handouts/general_seismicity.html
- <http://www.fema.gov/kids/quake.htm>

Authored by:
 C.V.R.Murty
 Indian Institute of Technology Kanpur
 Kanpur, India
 Sponsored by:
 Building Materials and Technology Promotion
 Council, New Delhi, India

This release is a property of IIT Kanpur and BMTPC New Delhi. It may be reproduced without changing its contents and with due acknowledgement. Suggestions/comments may be sent to: ecqtips@iitk.ac.in

How the ground shakes?

Seismic Waves

Large strain energy released during an earthquake travels as seismic waves in all directions through the Earth's layers, reflecting and refracting at each interface. These waves are of two types - *body waves* and *surface waves*; the latter are restricted to near the Earth's surface (Figure 1). Body waves consist of *Primary Waves (P-waves)* and *Secondary Waves (S-waves)*, and surface waves consist of *Love waves* and *Rayleigh waves*. Under P-waves, material particles undergo extensional and compressional strains along direction of energy transmission, but under S-waves, oscillate at right angles to it (Figure 2). Love waves cause surface motions similar to that by S-waves, but with no vertical component. Rayleigh wave makes a material particle oscillate in an elliptic path in the vertical plane (with horizontal motion along direction of energy transmission).

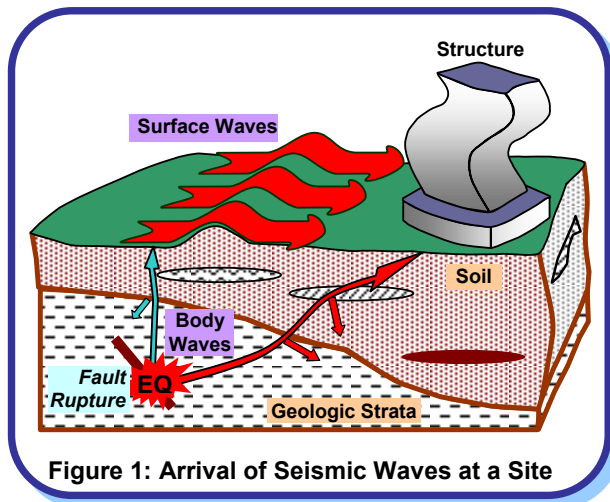
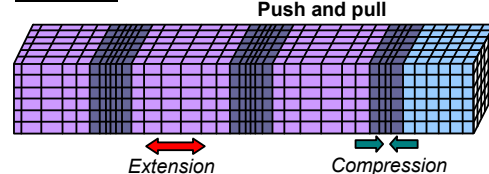

Figure 1: Arrival of Seismic Waves at a Site

P-waves are fastest, followed in sequence by S-, Love and Rayleigh waves. For example, in granites, P- and S-waves have speeds ~ 4.8 km/sec and ~ 3.0 km/sec, respectively. S-waves do not travel through liquids. S-waves in association with effects of Love waves cause maximum damage to structures by their racking motion on the surface in both vertical and horizontal directions. When P- and S-waves reach the Earth's surface, most of their energy is reflected back. Some of this energy is returned back to the surface by reflections at different layers of soil and rock. Shaking is more severe (about twice as much) at the Earth's surface than at substantial depths. This is often the basis for designing structures buried underground for smaller levels of acceleration than those above the ground.

P-Waves



S-Waves

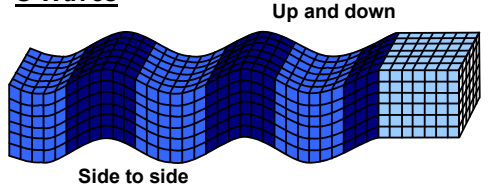

Love Waves

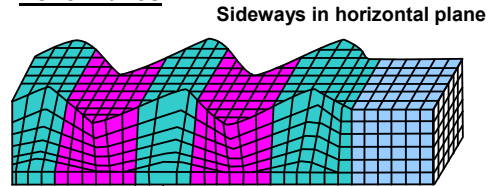

Rayleigh Waves

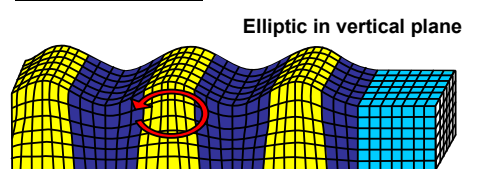

Figure 2:
Motions caused by Body and Surface Waves
(Adapted from FEMA 99, *Non-Technical
Explanation of the NEHRP Recommended
Provisions*)

Measuring Instruments

The instrument that measures earthquake shaking, a *seismograph*, has three components - the *sensor*, the *recorder* and the *timer*. The principle on which it works is simple and is explicitly reflected in the early seismograph (Figure 3) - a pen attached at the tip of an oscillating simple pendulum (a mass hung by a string from a support) marks on a chart paper that is held on a drum rotating at a constant speed. A magnet around the string provides required damping to control the amplitude of oscillations. The pendulum mass, string, magnet and support together constitute the *sensor*; the drum, pen and chart paper constitute the *recorder*; and the motor that rotates the drum at constant speed forms the *timer*.

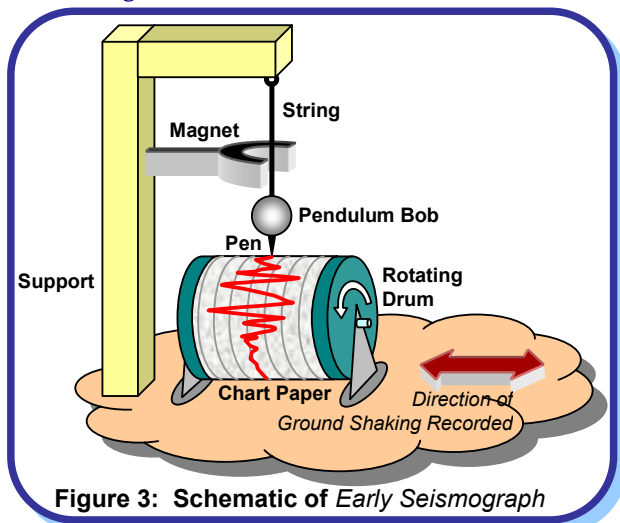

Figure 3: Schematic of Early Seismograph

One such instrument is required in each of the two orthogonal horizontal directions. Of course, for measuring vertical oscillations, the *string* pendulum (Figure 3) is replaced with a *spring* pendulum oscillating about a fulcrum. Some instruments do not have a timer device (*i.e.*, the drum holding the chart paper does not rotate). Such instruments provide only the maximum extent (or scope) of motion during the earthquake; for this reason they are called *seismoscopes*.

The analog instruments have evolved over time, but today, *digital instruments* using modern computer technology are more commonly used. The digital instrument records the ground motion on the memory of the microprocessor that is in-built in the instrument.

Strong Ground Motions

Shaking of ground on the Earth's surface is a net consequence of motions caused by seismic waves generated by energy release at each material point within the three-dimensional volume that ruptures at the fault. These waves arrive at various instants of time, have different amplitudes and carry different levels of energy. Thus, the motion at any site on ground is random in nature with its amplitude and direction varying randomly with time.

Large earthquakes at great distances can produce weak motions that may not damage structures or even be felt by humans. But, sensitive instruments can record these. This makes it possible to locate distant earthquakes. However, from engineering viewpoint, strong motions that can possibly damage structures are of interest. This can happen with earthquakes in the vicinity or even with large earthquakes at reasonable medium to large distances.

Characteristics of Strong Ground Motions

The motion of the ground can be described in terms of displacement, velocity or acceleration. The variation of ground acceleration with time recorded at a point on ground during an earthquake is called an *accelerogram*. The nature of accelerograms may vary (Figure 4) depending on energy released at source, type of slip at fault rupture, geology along the travel path from fault rupture to the Earth's surface, and

local soil (Figure 1). They carry distinct information regarding ground shaking; *peak amplitude*, *duration of strong shaking*, *frequency content* (*e.g.*, amplitude of shaking associated with each frequency) and *energy content* (*i.e.*, energy carried by ground shaking at each frequency) are often used to distinguish them.

Peak amplitude (*peak ground acceleration, PGA*) is physically intuitive. For instance, a horizontal PGA value of $0.6g$ (= 0.6 times the acceleration due to gravity) suggests that the movement of the ground can cause a maximum horizontal force on a rigid structure equal to 60% of its weight. In a rigid structure, all points in it move with the ground by the same amount, and hence experience the same maximum acceleration of PGA. Horizontal PGA values greater than $1.0g$ were recorded during the 1994 Northridge Earthquake in USA. Usually, strong ground motions carry significant energy associated with shaking of frequencies in the range 0.03-30Hz (*i.e.*, *cycles per sec*).

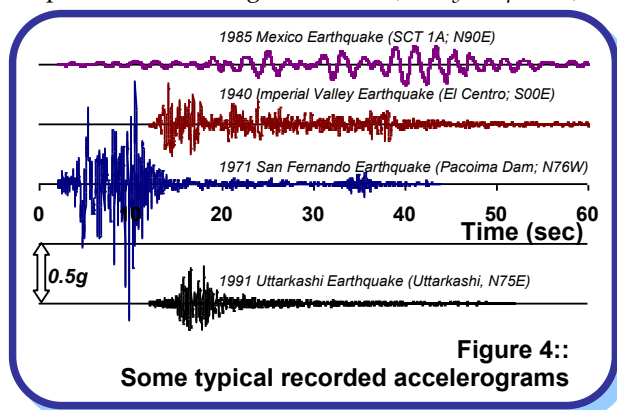

Figure 4: Some typical recorded accelerograms

Generally, the maximum amplitudes of horizontal motions in the two orthogonal directions are about the same. However, the maximum amplitude in the vertical direction is usually less than that in the horizontal direction. In design codes, the vertical design acceleration is taken as $1/2$ to $2/3$ of the horizontal design acceleration. In contrast, the maximum horizontal and vertical ground accelerations *in the vicinity* of the fault rupture do not seem to have such a correlation.

Resource Material

Bolt, B.A., (1999), *Earthquakes*, Fourth Edition, W. H. Freeman and Company, New York, USA

Authored by:

C.V.R.Murty
Indian Institute of Technology Kanpur
Kanpur, India

Sponsored by:

Building Materials and Technology Promotion
Council, New Delhi, India

This release is a property of IIT Kanpur and BMTPC New Delhi. It may be reproduced without changing its contents and with due acknowledgement. Suggestions/comments may be sent to: egtips@iitk.ac.in.

To see other IITK-BMTPC Earthquake Tips, see www.nicce.org

What are Magnitude and Intensity?

Terminology

The point on the fault where slip starts is the *Focus* or *Hypocenter*, and the point vertically above this on the surface of the Earth is the *Epicenter* (Figure 1). The depth of focus from the epicenter, called as *Focal Depth*, is an important parameter in determining the damaging potential of an earthquake. Most of the damaging earthquakes have shallow focus with focal depths less than about 70km. Distance from epicenter to any point of interest is called *epicentral distance*.

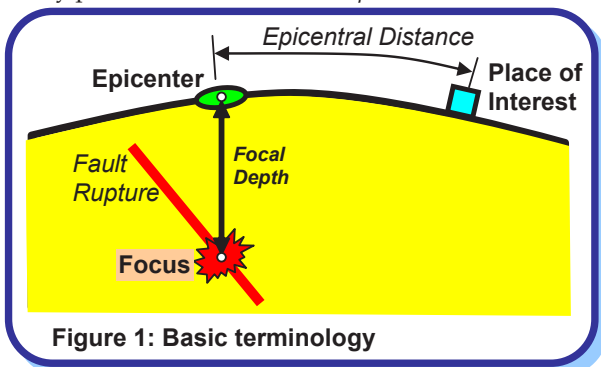

Figure 1: Basic terminology

A number of smaller size earthquakes take place before and after a big earthquake (*i.e.*, the *Main Shock*). Those occurring before the big one are called *Foreshocks*, and the ones after are called *Aftershocks*.

Magnitude

Magnitude is a *quantitative* measure of the actual size of the earthquake. Professor Charles Richter noticed that (a) at the same distance, seismograms (records of earthquake ground vibration) of larger earthquakes have bigger wave amplitude than those of smaller earthquakes; and (b) for a given earthquake, seismograms at farther distances have smaller wave amplitude than those at close distances. These prompted him to propose the now commonly used magnitude scale, the *Richter Scale*. It is obtained from the seismograms and accounts for the dependence of waveform amplitude on epicentral distance. This scale is also called *Local Magnitude* scale. There are other magnitude scales, like the *Body Wave Magnitude*, *Surface Wave Magnitude* and *Wave Energy Magnitude*. These *numerical* magnitude scales have no upper and lower limits; the magnitude of a very small earthquake can be zero or even negative.

An increase in magnitude (M) by 1.0 implies 10 times higher waveform amplitude and about 31 times higher energy released. For instance, energy released in a $M7.7$ earthquake is about 31 times that released in a $M6.7$ earthquake, and is about 1000 ($\approx 31 \times 31$) times that released in a $M5.7$ earthquake. Most of the energy

released goes into heat and fracturing the rocks, and only a small fraction of it (fortunately) goes into the seismic waves that travel to large distances causing shaking of the ground en-route and hence damage to structures. (*Did you know?* The energy released by a $M6.3$ earthquake is equivalent to that released by the 1945 Atom Bomb dropped on Hiroshima!!)

Earthquakes are often classified into different groups based on their size (Table 1). Annual average number of earthquakes across the Earth in each of these groups is also shown in the table; it indicates that on an average one *Great Earthquake* occurs each year.

Table 1: Global occurrence of earthquakes

Group	Magnitude	Annual Average Number
Great	8 and higher	1
Major	7 - 7.9	18
Strong	6 - 6.9	120
Moderate	5 - 5.9	800
Light	4 - 4.9	6,200 (estimated)
Minor	3 - 3.9	49,000 (estimated)
Very Minor	< 3.0	M2-3: ~1,000/day; M1-2: ~8,000/day

Source: <http://neic.usgs.gov/neis/eqlists/eqstats.html>

Intensity

Intensity is a *qualitative* measure of the actual shaking at a location during an earthquake, and is assigned as *Roman Capital Numerals*. There are many intensity scales. Two commonly used ones are the *Modified Mercalli Intensity (MMI) Scale* and the *MSK Scale*. Both scales are quite similar and range from I (least perceptible) to XII (most severe). The intensity scales are based on three features of shaking – perception by people and animals, performance of buildings, and changes to natural surroundings. Table 2 gives the description of Intensity VIII on MSK Scale.

The distribution of intensity at different places during an earthquake is shown graphically using *isoseismals*, lines joining places with equal seismic intensity (Figure 2).

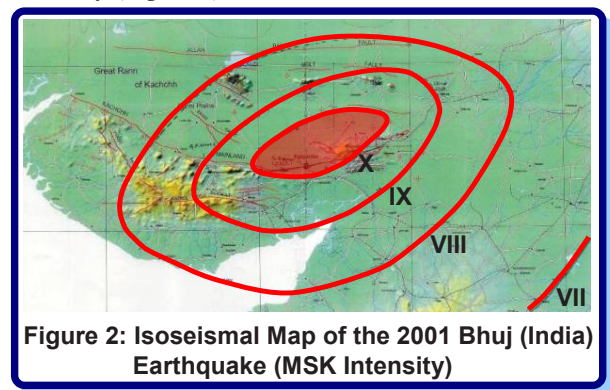

Figure 2: Isoseismal Map of the 2001 Bhuj (India) Earthquake (MSK Intensity)

Source:

<http://www.nicee.org/nicee/EQReports/Bhuj/isoseismal.html>

Table 2: Description of shaking intensity VIII as per MSK scale

Intensity VIII - Destruction of Buildings	
(a)	Fright and panic. Also, persons driving motorcars are disturbed. Here and there branches of trees break off. Even heavy furniture moves and partly overturns. Hanging lamps are damaged in part.
(b)	Most buildings of Type C suffer damage of Grade 2, and few of Grade 3. Most buildings of Type B suffer damage of Grade 3, and most buildings of Type A suffer damage of Grade 4. Occasional breaking of pipe seams occurs. Memorials and monuments move and twist. Tombstones overturn. Stonewalls collapse.
(c)	Small landslips occur in hollows and on banked roads on steep slopes; cracks develop in ground up to widths of several centimeters. Water in lakes becomes turbid. New reservoirs come into existence. Dry wells refill and existing wells become dry. In many cases, changes in flow and level of water are observed.
Note:	
<ul style="list-style-type: none"> • Type A structures - rural constructions; Type B - ordinary masonry constructions; Type C - Well-built structures • Single, Few - about 5%; Many - about 50%; Most - about 75% • Grade 1 Damage - Slight damage; Grade 2 - Moderate damage; Grade 3 - Heavy damage; Grade 4 - Destruction; Grade 5 - Total damage 	

Basic Difference: Magnitude versus Intensity

Magnitude of an earthquake is a measure of its size. For instance, one can measure the size of an earthquake by the amount of strain energy released by the fault rupture. This means that the magnitude of the earthquake is a single value for a given earthquake. On the other hand, intensity is an indicator of the severity of shaking generated at a given location. Clearly, the severity of shaking is much higher near the epicenter than farther away. Thus, during the same earthquake of a certain magnitude, different locations experience different levels of intensity.

To elaborate this distinction, consider the analogy of an electric bulb (Figure 3). The illumination at a location near a 100-Watt bulb is higher than that farther away from it. While the bulb releases 100 Watts of energy, the intensity of light (or illumination, measured in lumens) at a location depends on the wattage of the bulb and its distance from the bulb. Here, the size of the bulb (100-Watt) is like the magnitude of an earthquake, and the illumination at a location like the intensity of shaking at that location.

Magnitude and Intensity in Seismic Design

One often asks: *Can my building withstand a magnitude 7.0 earthquake?* But, the M7.0 earthquake causes different shaking intensities at different locations, and the damage induced in buildings at these locations is different. Thus, indeed it is particular levels of intensity of shaking that buildings and structures are designed to resist, and not so much the magnitude. The peak ground acceleration (PGA), i.e., maximum acceleration experienced by the ground during shaking, is one way of quantifying the severity of the ground shaking. Approximate empirical correlations are available between the MM intensities and the PGA that may be experienced (e.g., Table 3). For instance, during the 2001 Bhuj earthquake, the area

enclosed by the isoseismal VIII (Figure 2) may have experienced a PGA of about 0.25-0.30g. However, now strong ground motion records from seismic instruments are relied upon to quantify destructive ground shaking. These are critical for cost-effective earthquake-resistant design.

Table 3: PGAs during shaking of different intensities

MMI	V	VI	VII	VIII	IX	X
PGA (g)	0.03-0.04	0.06-0.07	0.10-0.15	0.25-0.30	0.50-0.55	>0.60

Source: B.A.Bolt, Earthquakes, W.H.Freeman and Co., New York, 1993

Based on data from past earthquakes, scientists Gutenberg and Richter in 1956 provided an approximate correlation between the Local Magnitude M_L of an earthquake with the intensity I_0 sustained in the epicentral area as: $M_L \approx \frac{2}{3} I_0 + 1$. (For using this equation, the Roman numbers of intensity are replaced with the corresponding Arabic numerals, e.g., intensity IX with 9.0). There are several different relations proposed by other scientists.

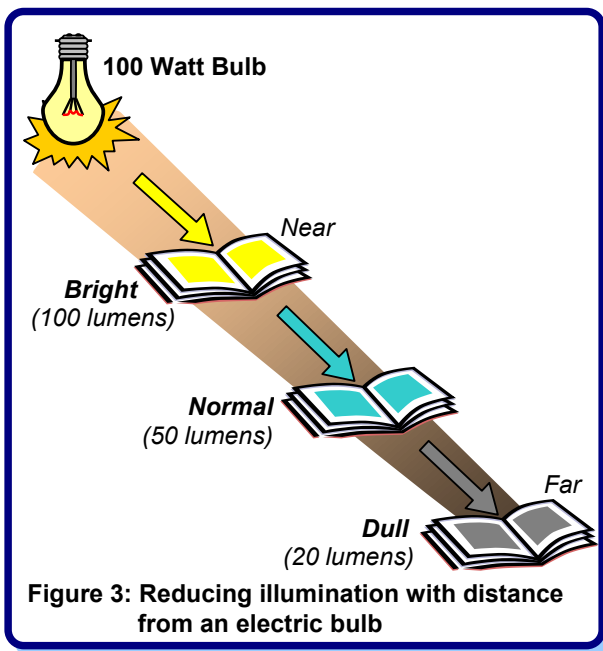

Figure 3: Reducing illumination with distance from an electric bulb

Resource Material

Richter,C.F., (1958), *Elementary Seismology*, W. H. Freeman and Company Inc, San Francisco, USA. (Indian Reprint in 1969 by Eurasia Publishing House Private Limited, New Delhi)
http://neic.usgs.gov/neis/general/handouts/magnitude_intensity.html

Authored by:
 C.V.R.Murty
 Indian Institute of Technology Kanpur
 Kanpur, India
 Sponsored by:
 Building Materials and Technology Promotion
 Council, New Delhi, India

This release is a property of IIT Kanpur and BMTPC New Delhi. It may be reproduced without changing its contents and with due acknowledgement.
 Suggestions/comments may be sent to: eqtips@iitk.ac.in
 To see other IITK-BMTPC Earthquake Tips, visit www.nicee.org



Where are the Seismic Zones in India?

Basic Geography and Tectonic Features

India lies at the northwestern end of the *Indo-Australian Plate*, which encompasses India, Australia, a major portion of the Indian Ocean and other smaller countries. This plate is colliding against the huge *Eurasian Plate* (Figure 1) and going under the Eurasian Plate; this process of one tectonic plate getting under another is called *subduction*. A sea, *Tethys*, separated these plates before they collided. Part of the lithosphere, the Earth's Crust, is covered by oceans and the rest by the continents. The former can undergo subduction at great depths when it converges against another plate, but the latter is buoyant and so tends to remain close to the surface. When continents converge, large amounts of shortening and thickening takes place, like at the Himalayas and the Tibet.

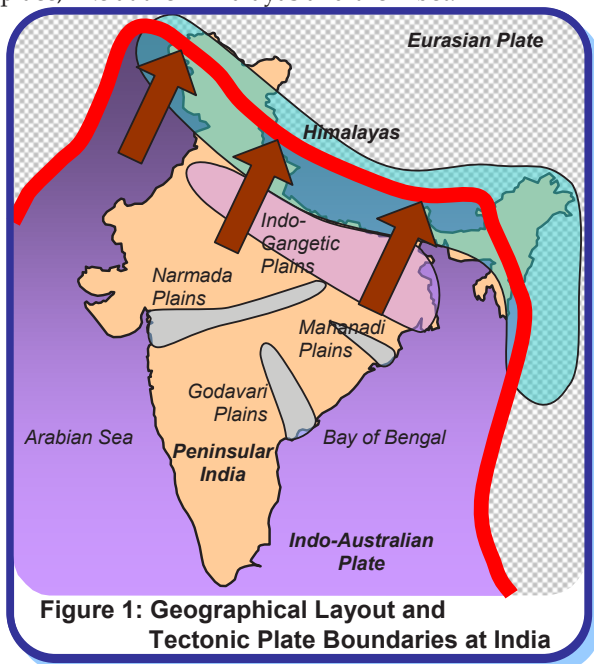

Figure 1: Geographical Layout and Tectonic Plate Boundaries at India

Three chief tectonic sub-regions of India are the mighty *Himalayas* along the north, the plains of the Ganges and other rivers, and the peninsula. The Himalayas consist primarily of sediments accumulated over long geological time in the *Tethys*. The Indo-Gangetic basin with deep alluvium is a great depression caused by the load of the Himalayas on the continent. The peninsular part of the country consists of ancient rocks deformed in the past Himalayan-like collisions. Erosion has exposed the roots of the old mountains and removed most of the topography. The rocks are very hard, but are softened by weathering near the surface. Before the Himalayan collision, several tens of millions of years ago, lava flowed

across the central part of peninsular India leaving layers of basalt rock. Coastal areas like Kachchh show marine deposits testifying to submergence under the sea millions of years ago.

Prominent Past Earthquakes in India

A number of significant earthquakes occurred in and around India over the past century (Figure 2). Some of these occurred in populated and urbanized areas and hence caused great damage. Many went unnoticed, as they occurred deep under the Earth's surface or in relatively un-inhabited places. Some of the damaging and recent earthquakes are listed in Table 1. Most earthquakes occur along the Himalayan plate boundary (these are *inter-plate* earthquakes), but a number of earthquakes have also occurred in the peninsular region (these are *intra-plate* earthquakes).

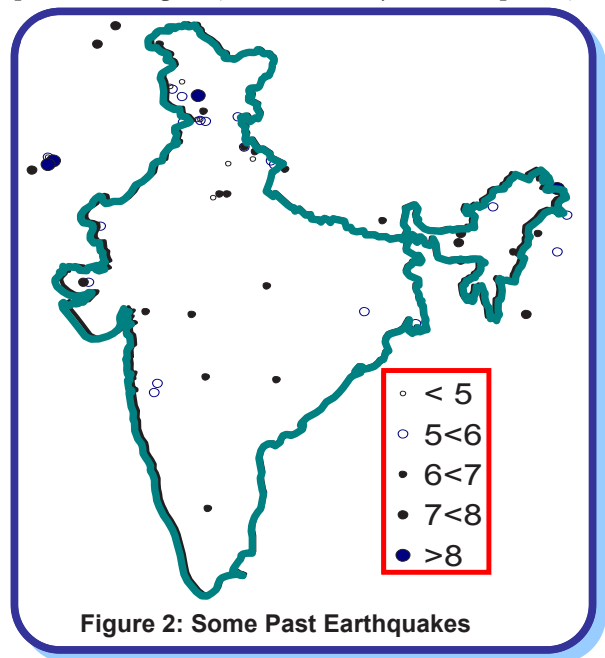

Figure 2: Some Past Earthquakes

Four Great earthquakes ($M > 8$) occurred in a span of 53 years from 1897 to 1950; the January 2001 Bhuj earthquake ($M 7.7$) is almost as large. Each of these caused disasters, but also allowed us to learn about earthquakes and to advance earthquake engineering. For instance, 1819 Cutch Earthquake produced an unprecedented $\sim 3m$ high uplift of the ground over $100km$ (called *Allah Bund*). The 1897 Assam Earthquake caused severe damage up to $500km$ radial distances; the type of damage sustained led to improvements in the intensity scale from I-X to I-XII. Extensive liquefaction of the ground took place over a length of $300km$ (called the *Slump Belt*) during 1934 Bihar-Nepal earthquake in which many structures went afloat.

Where are the Seismic Zones in India?

Table 1: Some Past Earthquakes in India

Date	Event	Time	Magnitude	Max. Intensity	Deaths
16 June 1819	Cutch	11:00	8.3	VIII	1,500
12 June 1897	Assam	17:11	8.7	XII	1,500
8 Feb. 1900	Coimbatore	03:11	6.0	X	Nil
4 Apr. 1905	Kangra	06:20	8.6	X	19,000
15 Jan. 1934	Bihar-Nepal	14:13	8.4	X	11,000
31 May 1935	Quetta	03:03	7.6	X	30,000
15 Aug. 1950	Assam	19:31	8.5	X	1,530
21 Jul. 1956	Anjar	21:02	7.0	IX	115
10 Dec. 1967	Koyna	04:30	6.5	VIII	200
23 Mar. 1970	Bharuch	20:56	5.4	VII	30
21 Aug. 1988	Bihar-Nepal	04:39	6.6	IX	1,004
20 Oct. 1991	Uttarkashi	02:53	6.6	IX	768
30 Sep. 1993	Killari (Latur)	03:53	6.4	IX	7,928
22 May 1997	Jabalpur	04:22	6.0	VIII	38
29 Mar. 1999	Chamoli	12:35	6.6	VIII	63
26 Jan. 2001	Bhuj	08:46	7.7	X	13,805

The timing of the earthquake during the day and during the year critically determines the number of casualties. Casualties are expected to be high for earthquakes that strike during cold winter nights, when most of the population is indoors.

Seismic Zones of India

The varying geology at different locations in the country implies that the likelihood of damaging earthquakes taking place at different locations is different. Thus, a seismic zone map is required to identify these regions. Based on the levels of intensities sustained during damaging past earthquakes, the 1970 version of the zone map subdivided India into five zones - I, II, III, IV and V (Figure 3). The maximum Modified Mercalli (MM) intensity of seismic shaking expected in these zones were V or less, VI, VII, VIII, and IX and higher, respectively. Parts of Himalayan boundary in the north and northeast, and the Kachchh area in the west were classified as zone V.

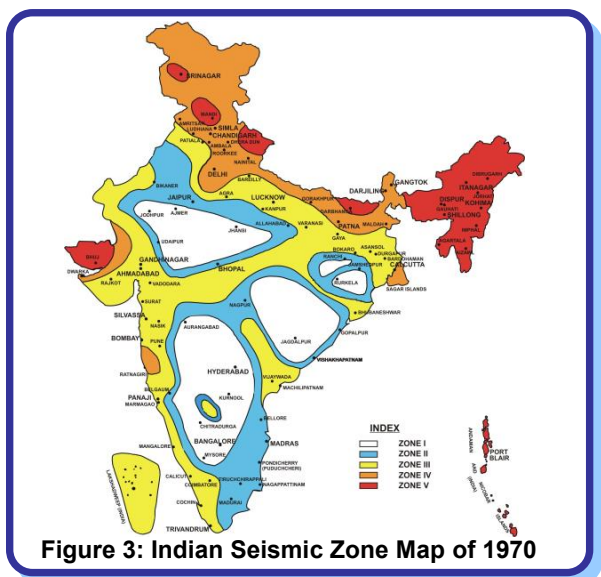

Figure 3: Indian Seismic Zone Map of 1970

The seismic zone maps are revised from time to time as more understanding is gained on the geology, the seismotectonics and the seismic activity in the country. The Indian Standards provided the first seismic zone map in 1962, which was later revised in

1967 and again in 1970. The map has been revised again in 2002 (Figure 4), and it now has only four seismic zones - II, III, IV and V. The areas falling in seismic zone I in the 1970 version of the map are merged with those of seismic zone II. Also, the seismic zone map in the peninsular region has been modified. Madras now comes in seismic zone III as against in zone II in the 1970 version of the map. This 2002 seismic zone map is not the final word on the seismic hazard of the country, and hence there can be no sense of complacency in this regard.

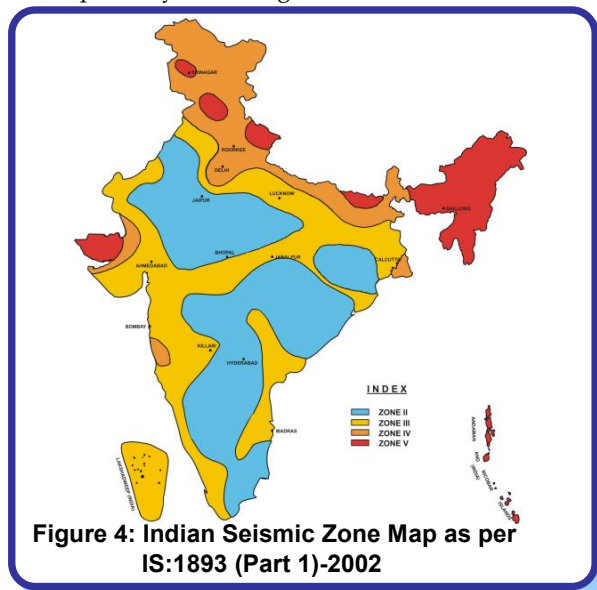

Figure 4: Indian Seismic Zone Map as per IS:1893 (Part 1)-2002

The national Seismic Zone Map presents a large-scale view of the seismic zones in the country. Local variations in soil type and geology cannot be represented at that scale. Therefore, for important projects, such as a major dam or a nuclear power plant, the seismic hazard is evaluated specifically for that site. Also, for the purposes of urban planning, metropolitan areas are microzoned. Seismic microzonation accounts for local variations in geology, local soil profile, etc.,

Resource Material

- BMTPC, (1997), *Vulnerability Atlas of India*, Building Materials and Technology Promotion Council, Ministry of Urban Development, Government of India, New Delhi.
- Dasgupta,S., et al, (2000), *Seismotectonic Atlas of Indian and its Environs*, Geological Survey of India.
- IS:1893, (1984), *Indian Standard Criteria for Earthquake Resistant Design of Structures*, Bureau of Indian Standards, New Delhi.

Authored by:
 C.V.R.Murty
 Indian Institute of Technology Kanpur
 Kanpur, India
 Sponsored by:
 Building Materials and Technology Promotion
 Council, New Delhi, India

This release is a property of IIT Kanpur and BMTPC New Delhi. It may be reproduced without changing its contents and with due acknowledgement.
 Suggestions/comments may be sent to: eqtips@iitk.ac.in
 To see other IITK-BMTPC Earthquake Tips, visit www.nicee.org
 July 2002; Revised August 2004

What are the Seismic Effects on Structures?

Inertia Forces in Structures

Earthquake causes shaking of the ground. So a building resting on it will experience motion at its base. From *Newton's First Law of Motion*, even though the base of the building moves with the ground, the roof has a tendency to stay in its original position. But since the walls and columns are connected to it, they drag the roof along with them. *This is much like the situation that you are faced with when the bus you are standing in suddenly starts; your feet move with the bus, but your upper body tends to stay back making you fall backwards!!* This tendency to continue to remain in the previous position is known as *inertia*. In the building, since the walls or columns are flexible, the motion of the roof is different from that of the ground (Figure 1).

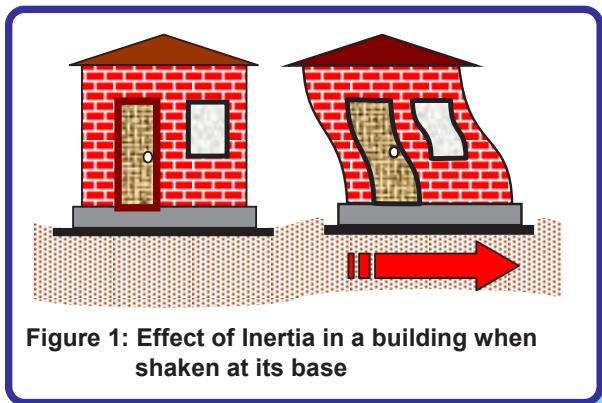

Figure 1: Effect of Inertia in a building when shaken at its base

Consider a building whose roof is supported on columns (Figure 2). *Coming back to the analogy of yourself on the bus: when the bus suddenly starts, you are thrown backwards as if someone has applied a force on the upper body.* Similarly, when the ground moves, even the building is thrown backwards, and the roof experiences a force, called *inertia force*. If the roof has a mass M and experiences an acceleration a , then from *Newton's Second Law of Motion*, the *inertia force* F_i is mass M times acceleration a , and its direction is opposite to that of the acceleration. Clearly, more mass means higher inertia force. Therefore, lighter buildings sustain the earthquake shaking better.

Effect of Deformations in Structures

The inertia force experienced by the roof is transferred to the ground via the columns, causing forces in columns. These forces generated in the columns can also be understood in another way. During earthquake shaking, the columns undergo relative movement between their ends. In Figure 2, this movement is shown as quantity u between the roof and the ground. But, given a free option, columns

would like to come back to the straight vertical position, *i.e.*, columns resist deformations. In the straight vertical position, the columns carry no horizontal earthquake force through them. But, when forced to bend, they develop internal forces. The larger is the relative horizontal displacement u between the top and bottom of the column, the larger this internal force in columns. Also, the stiffer the columns are (*i.e.*, bigger is the column size), larger is this force. For this reason, these internal forces in the columns are called *stiffness forces*. In fact, the stiffness force in a column is the column stiffness times the relative displacement between its ends.

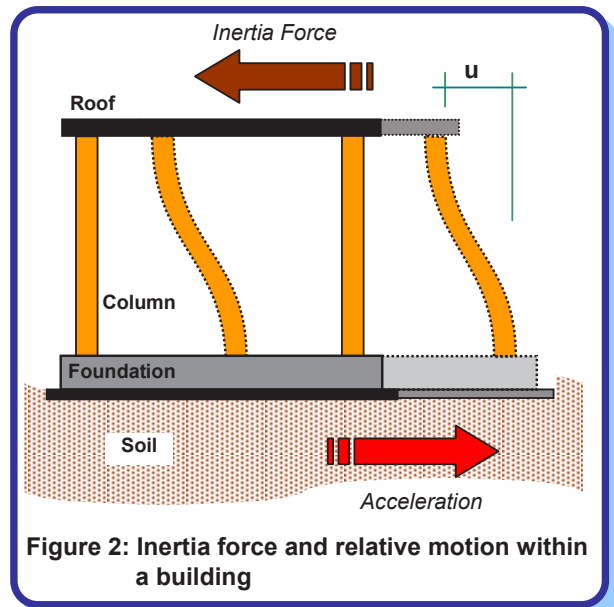

Figure 2: Inertia force and relative motion within a building

Horizontal and Vertical Shaking

Earthquake causes shaking of the ground in all three directions - along the two horizontal directions (X and Y , say), and the vertical direction (Z , say) (Figure 3). Also, during the earthquake, the ground shakes randomly *back and forth* (- and +) along each of these X , Y and Z directions. All structures are primarily designed to carry the gravity loads, *i.e.*, they are designed for a force equal to the mass M (this includes mass due to own weight and imposed loads) times the acceleration due to gravity g acting in the vertical downward direction ($-Z$). The downward force Mg is called the *gravity load*. The vertical acceleration during ground shaking either adds to or subtracts from the acceleration due to gravity. Since factors of safety are used in the design of structures to resist the gravity loads, usually most structures tend to be adequate against vertical shaking.

What are the Seismic Effects on Structures?

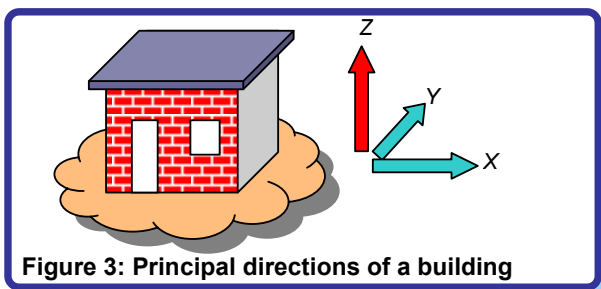

Figure 3: Principal directions of a building

However, horizontal shaking along X and Y directions (both + and - directions of each) remains a concern. Structures designed for gravity loads, in general, may not be able to safely sustain the effects of horizontal earthquake shaking. Hence, it is necessary to ensure adequacy of the structures against horizontal earthquake effects.

Flow of Inertia Forces to Foundations

Under horizontal shaking of the ground, horizontal inertia forces are generated at level of the mass of the structure (usually situated at the floor levels). These lateral inertia forces are transferred by the floor slab to the walls or columns, to the foundations, and finally to the soil system underneath (Figure 4). So, each of these structural elements (floor slabs, walls, columns, and foundations) and the connections between them must be designed to safely transfer these inertia forces through them.

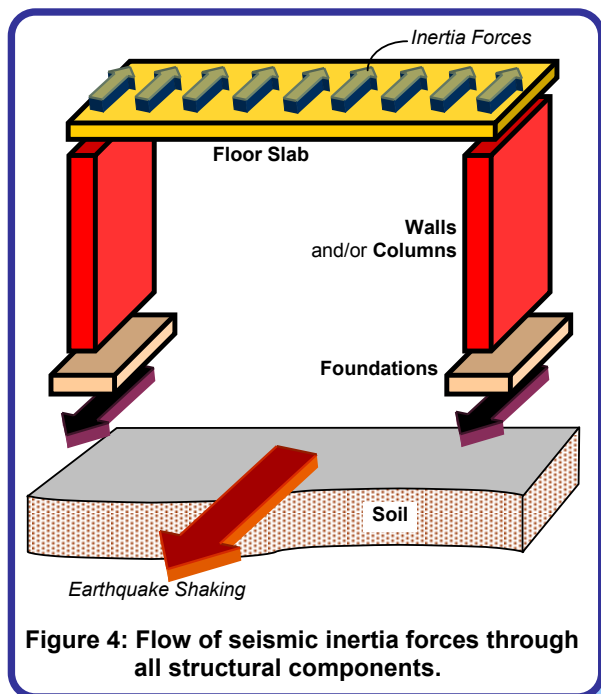
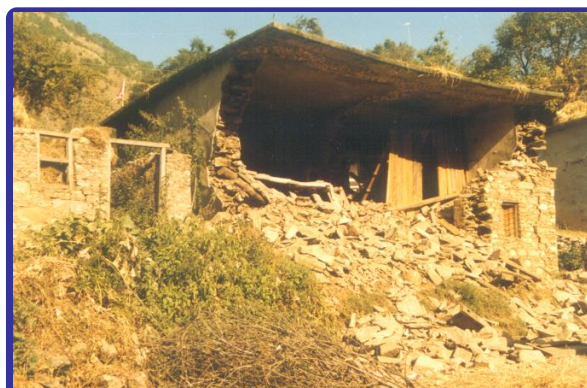

Figure 4: Flow of seismic inertia forces through all structural components.

Walls or columns are the most critical elements in transferring the inertia forces. But, in traditional construction, floor slabs and beams receive more care and attention during design and construction, than walls and columns. Walls are relatively thin and often made of brittle material like masonry. They are poor in carrying horizontal earthquake inertia forces along the

direction of their thickness. Failures of masonry walls have been observed in many earthquakes in the past (e.g., Figure 5a). Similarly, poorly designed and constructed reinforced concrete columns can be disastrous. The failure of the ground storey columns resulted in numerous building collapses during the 2001 Bhuj (India) earthquake (Figure 5b).



(a) Partial collapse of stone masonry walls during 1991 Uttarkashi (India) earthquake



(b) Collapse of reinforced concrete columns (and building) during 2001 Bhuj (India) earthquake

Figure 5: Importance of designing walls/columns for horizontal earthquake forces.

Resource Material

Chopra,A.K., (1980), *Dynamics of Structures - A Primer*, EERI Monograph, Earthquake Engineering Research Institute, USA.

Next Upcoming Tip

What is the Influence of Architectural Features on Earthquake Behaviour of Buildings?

Authored by:

C.V.R.Murty
Indian Institute of Technology Kanpur
Kanpur, India

Sponsored by:

Building Materials and Technology Promotion Council, New Delhi, India

This release is a property of IIT Kanpur and BMTPC New Delhi. It may be reproduced without changing its contents and with due acknowledgement.

Suggestions/comments may be sent to: eqtips@iitk.ac.in

To see previous IITK-BMTPC Earthquake Tips, visit www.nicee.org

How Architectural Features Affect Buildings During Earthquakes?

Importance of Architectural Features

The behaviour of a building during earthquakes depends critically on its overall shape, size and geometry, in addition to how the earthquake forces are carried to the ground. Hence, at the planning stage itself, architects and structural engineers must work together to ensure that the unfavourable features are avoided and a good building configuration is chosen.

The importance of the configuration of a building was aptly summarised by Late Henry Degenkolb, a noted Earthquake Engineer of USA, as:

"If we have a poor configuration to start with, all the engineer can do is to provide a band-aid - improve a basically poor solution as best as he can. Conversely, if we start-off with a good configuration and reasonable framing system, even a poor engineer cannot harm its ultimate performance too much."

Architectural Features

A desire to create an aesthetic and functionally efficient structure drives architects to conceive wonderful and imaginative structures. Sometimes the *shape* of the building catches the eye of the visitor, sometimes the *structural system* appeals, and in other occasions *both shape and structural system* work together to make the structure a marvel. However, each of these choices of shapes and structure has significant bearing on the performance of the building during strong earthquakes. The wide range of structural damages observed during past earthquakes across the world is very educative in identifying structural configurations that are desirable versus those which must be avoided.

Size of Buildings: In tall buildings with large height-to-base size ratio (Figure 1a), the horizontal movement of the floors during ground shaking is large. In short but very long buildings (Figure 1b), the damaging effects during earthquake shaking are many. And, in buildings with large plan area like warehouses (Figure 1c), the horizontal seismic forces can be excessive to be carried by columns and walls.

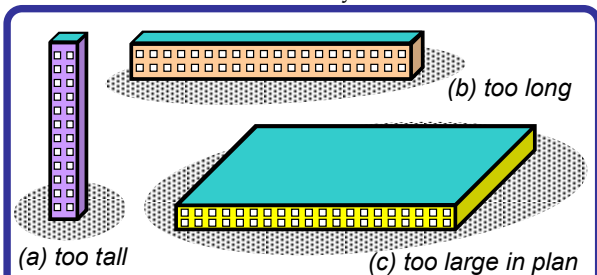

Figure 1: Buildings with one of their overall sizes much larger or much smaller than the other two, do not perform well during earthquakes.

Horizontal Layout of Buildings: In general, buildings with simple geometry in plan (Figure 2a) have performed well during strong earthquakes. Buildings with re-entrant corners, like those U, V, H and + shaped in plan (Figure 2b), have sustained significant damage. Many times, the bad effects of these interior corners in the plan of buildings are avoided by making the buildings in two parts. For example, an L-shaped plan can be broken up into two rectangular plan shapes using a separation joint at the junction (Figure 2c). Often, the plan is simple, but the columns/walls are not equally distributed in plan. Buildings with such features tend to twist during earthquake shaking. A discussion in this aspect will be presented in the upcoming IITK-BMTPC Earthquake Tip 7 on How Buildings Twist During Earthquakes?

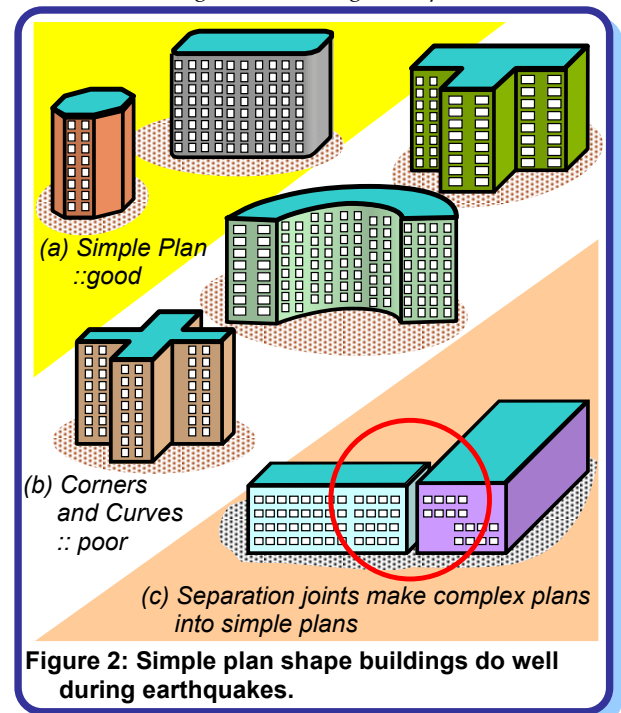

Figure 2: Simple plan shape buildings do well during earthquakes.

Vertical Layout of Buildings: The earthquake forces developed at different floor levels in a building need to be brought down along the height to the ground by the shortest path; any deviation or discontinuity in this load transfer path results in poor performance of the building. Buildings with vertical setbacks (like the hotel buildings with a few storeys wider than the rest) cause a sudden jump in earthquake forces at the level of discontinuity (Figure 3a). Buildings that have fewer columns or walls in a particular storey or with unusually tall storey (Figure 3b), tend to damage or collapse which is initiated in

How Architectural Features Affect Buildings During Earthquakes?

that storey. Many buildings with an open ground storey intended for parking collapsed or were severely damaged in Gujarat during the 2001 Bhuj earthquake.

Buildings on slopy ground have unequal height columns along the slope, which causes ill effects like twisting and damage in shorter columns (Figure 3c). Buildings with columns that hang or float on beams at an intermediate storey and do not go all the way to the foundation, have discontinuities in the load transfer path (Figure 3d). Some buildings have reinforced concrete walls to carry the earthquake loads to the foundation. Buildings, in which these walls do not go all the way to the ground but stop at an upper level, are liable to get severely damaged during earthquakes.

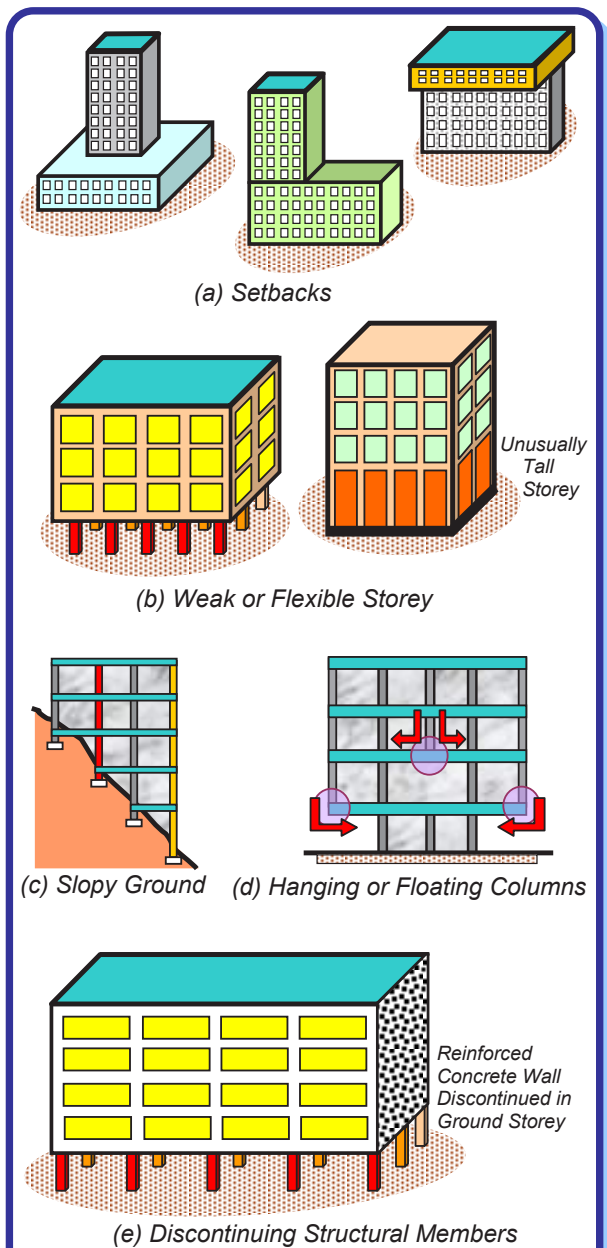

Figure 3: Sudden deviations in load transfer path along the height lead to poor performance of buildings.

Adjacency of Buildings: When two buildings are too close to each other, they may pound on each other during strong shaking. With increase in building height, this collision can be a greater problem. When building heights do not match (Figure 4), the roof of the shorter building may pound at the mid-height of the column of the taller one; this can be very dangerous.

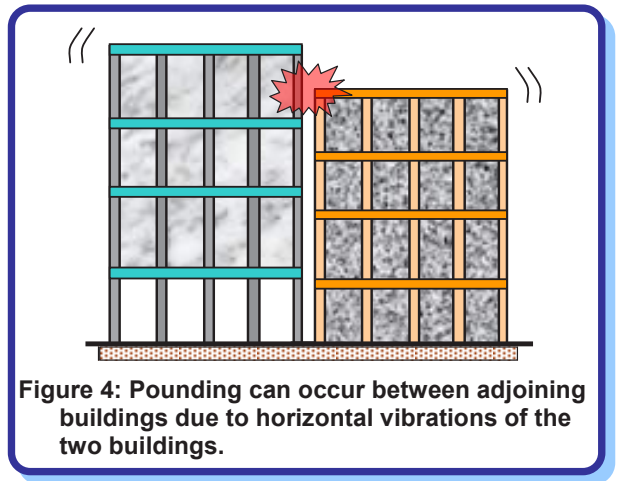

Figure 4: Pounding can occur between adjoining buildings due to horizontal vibrations of the two buildings.

Building Design and Codes...

Looking ahead, of course, one will continue to make buildings interesting rather than monotonous. However, this need not be done at the cost of poor behaviour and earthquake safety of buildings. Architectural features that are detrimental to earthquake response of buildings should be avoided. If not, they must be minimised. When irregular features are included in buildings, a considerably higher level of engineering effort is required in the structural design and yet the building may not be as good as one with simple architectural features.

Decisions made at the planning stage on building configuration are more important, or are known to have made greater difference, than accurate determination of code specified design forces.

Resource Material

Arnold,C., and Reitherman,R., (1982), *Building Configuration and Seismic Design*, John Wiley, USA.
Lagorio,HJ, (1990), *EARTHQUAKES An Architect's Guide to Non-Structural Seismic Hazard*, John Wiley & Sons, Inc., USA.

Next Upcoming Tip

How Buildings Twist During Earthquakes?

Authored by:
 C.V.R.Murty
 Indian Institute of Technology Kanpur
 Kanpur, India
 Sponsored by:
 Building Materials and Technology Promotion
 Council, New Delhi, India

This release is a property of IIT Kanpur and BMTPC New Delhi. It may be reproduced without changing its contents and with due acknowledgement.

Suggestions/comments may be sent to: eqtips@iitk.ac.in

To see previous IITK-BMTPC Earthquake Tips, visit www.nicee.org

September 2002

How Buildings Twist During Earthquakes?

Why a Building Twists

In your childhood, you must have sat on a rope swing - a wooden cradle tied with coir ropes to the sturdy branch of an old tree. The more modern versions of these swings can be seen today in the children's parks in urban areas; they have a plastic cradle tied with steel chains to a steel framework. Consider a rope swing that is tied identically with two equal ropes. It swings equally, when you sit in the middle of the cradle. Buildings too are like these rope swings; just that they are inverted swings (Figure 1). The vertical walls and columns are like the ropes, and the floor is like the cradle. Buildings vibrate back and forth during earthquakes. Buildings with more than one storey are like rope swings with more than one cradle.

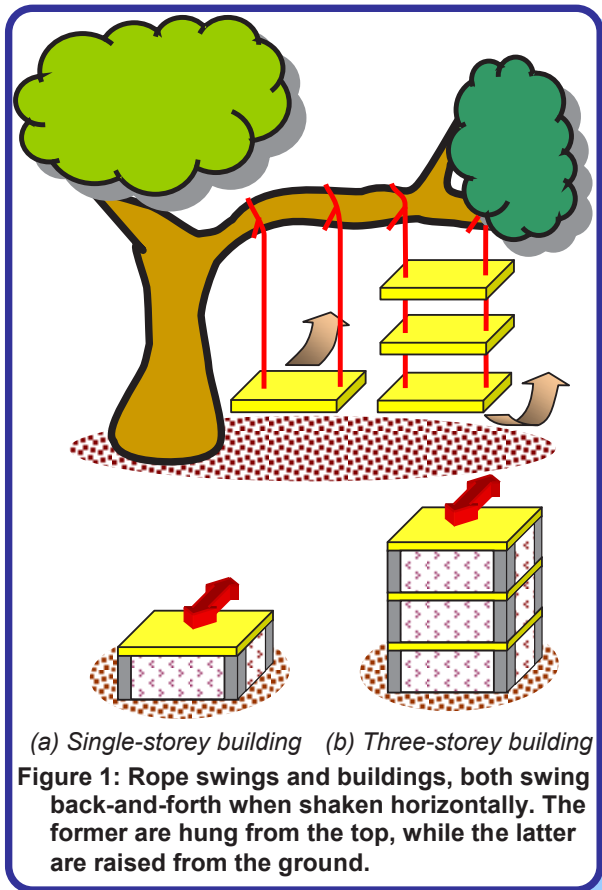

Figure 1: Rope swings and buildings, both swing back-and-forth when shaken horizontally. The former are hung from the top, while the latter are raised from the ground.

Thus, if you see from sky, a building with identical vertical members and that are uniformly placed in the two horizontal directions, when shaken at its base in a certain direction, swings back and forth such that all points on the floor move horizontally by the same amount in the direction in which it is shaken (Figure 2).

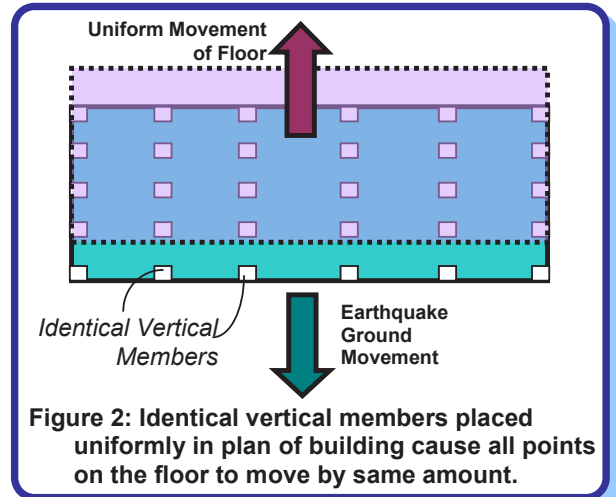

Figure 2: Identical vertical members placed uniformly in plan of building cause all points on the floor to move by same amount.

Again, let us go back to the rope swings on the tree: if you sit at one end of the cradle, it *twists* (i.e., moves more on the side you are sitting). This also happens sometimes when more of your friends bunch together and sit on one side of the swing. Likewise, if the mass on the floor of a building is more on one side (for instance, one side of a building may have a storage or a library), then that side of the building moves more under ground movement (Figure 3). This building moves such that its floors displace horizontally as well as rotate.

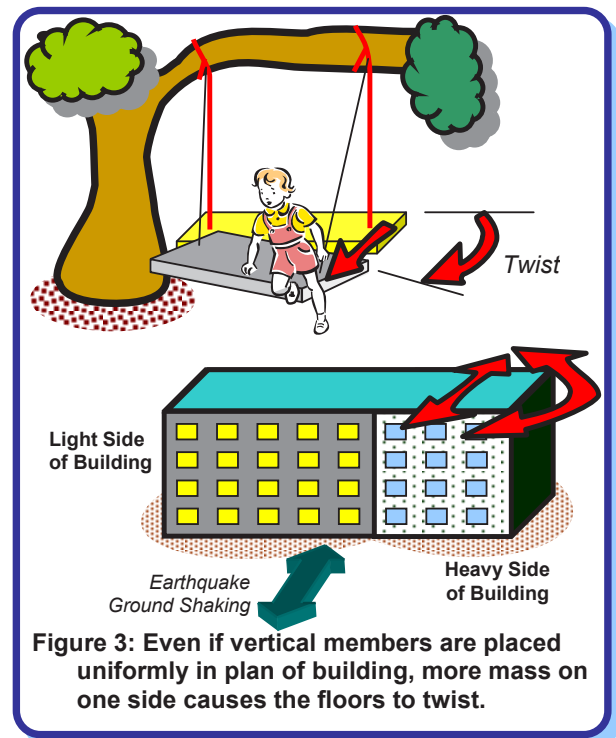
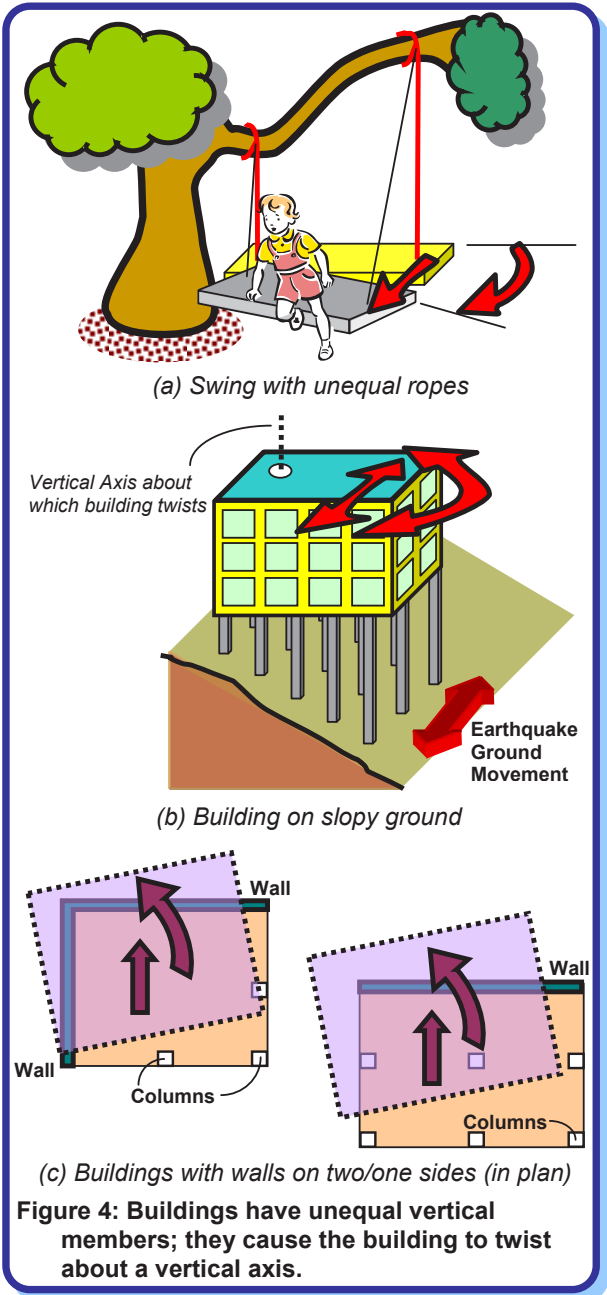

Figure 3: Even if vertical members are placed uniformly in plan of building, more mass on one side causes the floors to twist.

How Buildings Twist During Earthquakes?

Once more, let us consider the rope swing on the tree. This time let the two ropes with which the cradle is tied to the branch of the tree be different in length. Such a swing also *twists* even if you sit in the middle (Figure 4a). Similarly, in buildings with unequal vertical members (*i.e.*, columns and/or walls) also the floors twist about a vertical axis (Figure 4b) and displace horizontally. Likewise, buildings, which have walls only on two sides (or one side) and thin columns along the other, twist when shaken at the ground level (Figure 4c).



Buildings that are irregular shapes in plan tend to twist under earthquake shaking. For example, in a propped overhanging building (Figure 5), the overhanging portion swings on the relatively slender columns under it. The floors twist and displace horizontally.

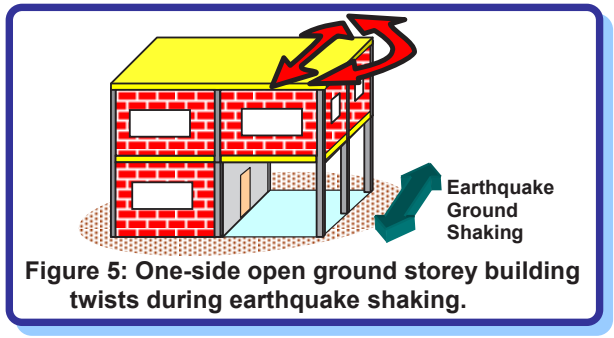

What Twist does to Building Members

Twist in buildings, called *torsion* by engineers, makes different portions at the same floor level to move horizontally by different amounts. This induces more damage in the columns and walls on the side that moves more (Figure 6). Many buildings have been severely affected by this excessive torsional behaviour during past earthquakes. It is best to minimize (if not completely avoid) this twist by ensuring that buildings have symmetry in plan (*i.e.*, uniformly distributed mass and uniformly placed vertical members). If this twist cannot be avoided, special calculations need to be done to account for this additional shear forces in the design of buildings; the Indian seismic code (IS 1893, 2002) has provisions for such calculations. But, for sure, buildings with twist will perform poorly during strong earthquake shaking.

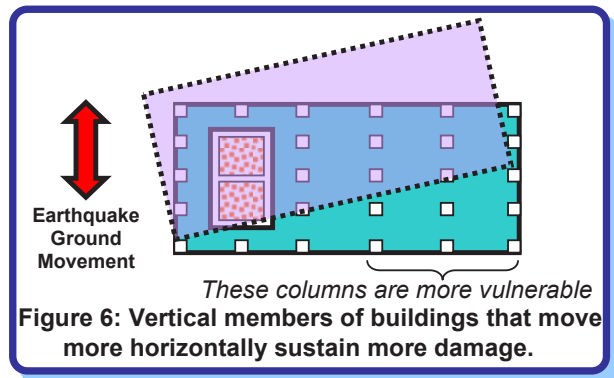

Resource Material

Arnold,C., and Reitherman,R., (1982), *Building Configuration and Seismic Design*, John Wiley, USA.
 Lagorio,H,J, (1990), *EARTHQUAKES An Architect's Guide to Non-Structural Seismic Hazard*, John Wiley & Sons, Inc., USA.

Next Upcoming Tip

What is the Seismic Design Philosophy for Buildings?

Authored by:
 C.V.R.Murty
 Indian Institute of Technology Kanpur
 Kanpur, India
Sponsored by:
 Building Materials and Technology Promotion
 Council, New Delhi, India

*This release is a property of IIT Kanpur and BMTPC New Delhi. It may be reproduced without changing its contents and with due acknowledgement.
 Suggestions/comments may be sent to: eqtips@iitk.ac.in
 To see previous IITK-BMTPC Earthquake Tips, visit www.nicee.org
 October 2002*

What is the Seismic Design Philosophy for Buildings?

The Earthquake Problem

Severity of ground shaking at a given location during an earthquake can be *minor*, *moderate* and *strong*. Relatively speaking, minor shaking occurs frequently, moderate shaking occasionally and strong shaking rarely. For instance, on average annually about 800 earthquakes of magnitude 5.0-5.9 occur in the world while the number is only about 18 for magnitude range 7.0-7.9 (see Table 1 of IITK-BMTPC Earthquake Tip 03 at www.nicee.org). So, should we design and construct a building to resist that *rare* earthquake shaking that may come only once in 500 years or even once in 2000 years at the chosen project site, even though the life of the building itself may be only 50 or 100 years? Since it costs money to provide additional earthquake safety in buildings, a conflict arises: *Should we do away with the design of buildings for earthquake effects? Or should we design the buildings to be "earthquake proof" wherein there is no damage during the strong but rare earthquake shaking?* Clearly, the former approach can lead to a major disaster, and the second approach is too expensive. Hence, the design philosophy should lie somewhere in between these two extremes.

Earthquake-Resistant Buildings

The engineers do not attempt to make *earthquake-proof buildings* that *will not* get damaged even during the rare but strong earthquake; such buildings will be too robust and also too expensive. Instead, the engineering intention is to make buildings *earthquake-resistant*; such buildings resist the effects of ground shaking, although they may get damaged severely but would not collapse during the strong earthquake. Thus, safety of people and contents is assured in earthquake-resistant buildings, and thereby a disaster is avoided. This is a major objective of seismic design codes throughout the world.

Earthquake Design Philosophy

The earthquake design philosophy may be summarized as follows (Figure 2):

- Under minor but frequent shaking, the main members of the building that carry vertical and horizontal forces should not be damaged; however building parts that do not carry load may sustain repairable damage.
- Under moderate but occasional shaking, the main members may sustain repairable damage, while the other parts of the building may be damaged such that they may even have to be replaced after the earthquake; and
- Under strong but rare shaking, the main members

may sustain severe (even irreparable) damage, but the building should not collapse.

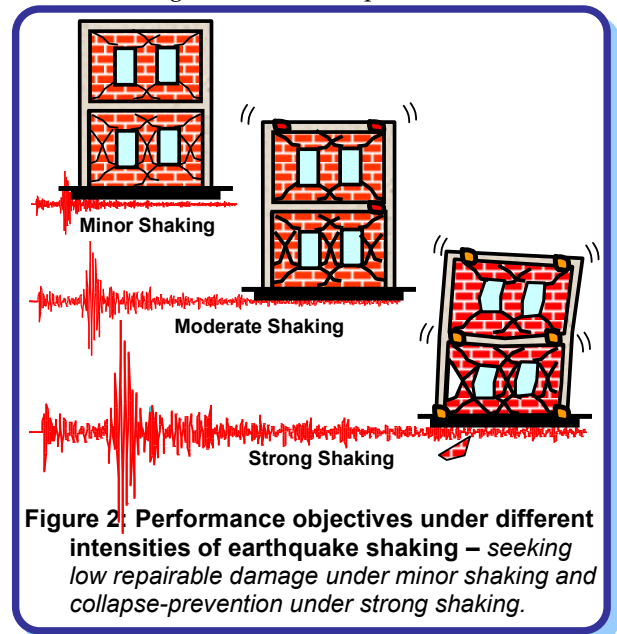

Figure 2: Performance objectives under different intensities of earthquake shaking – seeking low repairable damage under minor shaking and collapse-prevention under strong shaking.

Thus, after minor shaking, the building will be fully operational within a short time and the repair costs will be small. And, after moderate shaking, the building will be operational once the repair and strengthening of the damaged main members is completed. But, after a strong earthquake, the building may become dysfunctional for further use, but will stand so that people can be evacuated and property recovered.

The consequences of damage have to be kept in view in the design philosophy. For example, important buildings, like hospitals and fire stations, play a critical role in post-earthquake activities and must remain functional immediately after the earthquake. These structures must sustain very little damage and should be designed for a higher level of earthquake protection. Collapse of dams during earthquakes can cause flooding in the downstream reaches, which itself can be a secondary disaster. Therefore, dams (and similarly, nuclear power plants) should be designed for still higher level of earthquake motion.

Damage in Buildings: Unavoidable

Design of buildings to resist earthquakes involves *controlling the damage to acceptable levels at a reasonable cost*. Contrary to the common thinking that any crack in the building after an earthquake means the building is unsafe for habitation, engineers designing earthquake-resistant buildings recognize that some

What is the Seismic Design Philosophy for Buildings?

damage is unavoidable. Different types of damage (mainly visualized through cracks; especially so in concrete and masonry buildings) occur in buildings during earthquakes. Some of these cracks are acceptable (in terms of both their size and location), while others are not. For instance, in a reinforced concrete frame building with masonry filler walls between columns, the cracks between vertical columns and masonry filler walls are acceptable, but diagonal cracks running through the columns are not (Figure 3). In general, qualified technical professionals are knowledgeable of the causes and severity of damage in earthquake-resistant buildings.



Figure 3: Diagonal cracks in columns jeopardize vertical load carrying capacity of buildings - unacceptable damage.

Earthquake-resistant design is therefore concerned about ensuring that the damages in buildings during earthquakes are of the *acceptable* variety, and also that they occur at the right places and in right amounts. This approach of earthquake-resistant design is much like the use of electrical fuses in houses: to protect the entire electrical wiring and appliances in the house, you sacrifice some small parts of the electrical circuit, called fuses; these fuses are easily replaced after the electrical over-current. Likewise, to save the building from collapsing, you need to allow some pre-determined parts to undergo the acceptable type and level of damage.

Acceptable Damage: Ductility

So, the task now is to identify acceptable forms of damage and desirable building behaviour during earthquakes. To do this, let us first understand how different materials behave. Consider *white chalk* used to write on blackboards and *steel pins* with solid heads used to hold sheets of paper together. Yes... a chalk breaks easily!! On the contrary, a steel pin allows it to be bent back-and-forth. Engineers define the property that allows steel pins to bend back-and-forth by large amounts, as *ductility*; chalk is a *brittle* material.

Earthquake-resistant buildings, particularly their main elements, need to be built with ductility in them. Such buildings have the ability to sway back-and-forth during an earthquake, and to withstand earthquake effects with some damage, but without collapse (Figure 4). Ductility is one of the most important

factors affecting the building performance. Thus, earthquake-resistant design strives to predetermine the locations where damage takes place and then to provide good detailing at these locations to ensure ductile behaviour of the building.

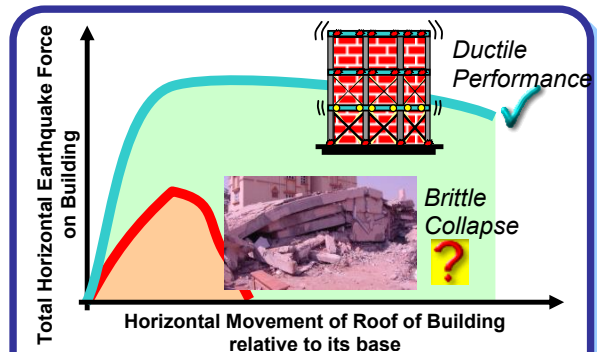

(a) Building performances during earthquakes: two extremes – the ductile and the brittle.



(b) Brittle failure of a reinforced concrete column

Figure 4: Ductile and brittle structures – seismic design attempts to avoid structures of the latter kind.

Resource Material

Naeim,F., Ed., (2001), *The Seismic Design Handbook*, Kluwer Academic Publishers, Boston, USA.
 Ambrose,J., and Vergun,D., (1999), *Design for Earthquakes*, John Wiley & Sons, Inc., New York.

Next Upcoming Tip

How to make buildings ductile for good seismic performance?

Authored by:

C.V.R.Murty
 Indian Institute of Technology Kanpur
 Kanpur, India

Sponsored by:

Building Materials and Technology Promotion
 Council, New Delhi, India

This release is a property of IIT Kanpur and BMTPC New Delhi. It may be reproduced without changing its contents and with due acknowledgement.

Suggestions/comments may be sent to: eqtips@iitk.ac.in

To see previous IITK-BMTPC Earthquake Tips, visit www.nicee.org

November 2002

How to Make Buildings Ductile for Good Seismic Performance?

Construction Materials

In India, most non-urban buildings are made in masonry. In the plains, masonry is generally made of burnt clay bricks and cement mortar. However, in hilly areas, stone masonry with mud mortar is more prevalent; but, in recent times, it is being replaced with cement mortar. Masonry can carry loads that cause *compression* (i.e., pressing together), but can hardly take load that causes *tension* (i.e., pulling apart) (Figure 1).

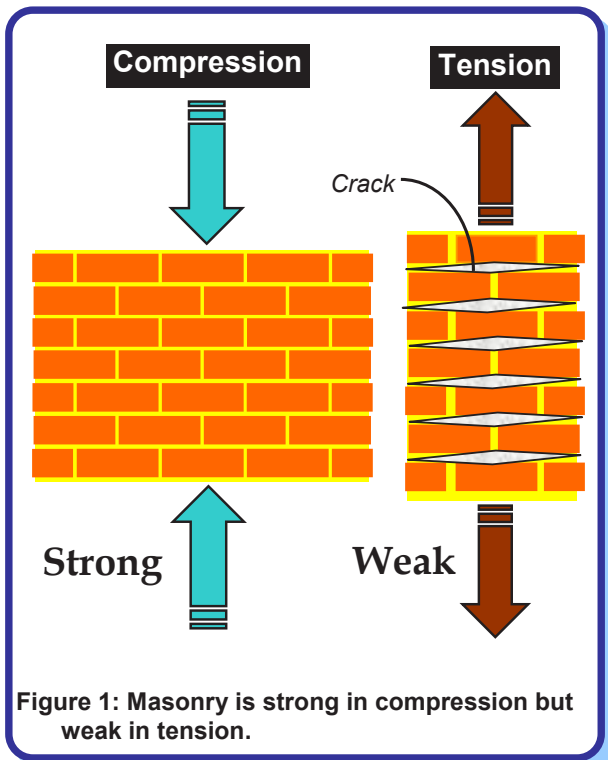

Concrete is another material that has been popularly used in building construction particularly over the last four decades. Cement concrete is made of crushed stone pieces (called *aggregate*), sand, cement and water mixed in appropriate proportions. Concrete is much stronger than masonry under *compressive* loads, but again its behaviour in tension is poor. The properties of concrete critically depend on the amount of water used in making concrete; too much and too little water, both can cause havoc. In general, both masonry and concrete are brittle, and fail suddenly.

Steel is used in masonry and concrete buildings as reinforcement bars of diameter ranging from 6mm to 40mm. Reinforcing steel can carry both tensile and compressive loads. Moreover, steel is a *ductile material*. This important property of ductility enables steel bars to undergo large elongation before breaking.

Concrete is used in buildings along with steel reinforcement bars. This composite material is called *reinforced cement concrete* or simply *reinforced concrete* (RC). The amount and location of steel in a member should be such that the failure of the member is by steel reaching its strength in tension before concrete reaches its strength in compression. This type of failure is *ductile failure*, and hence is preferred over a failure where concrete fails first in compression. Therefore, contrary to common thinking, providing too much steel in RC buildings can be harmful even!!

Capacity Design Concept

Let us take two bars of same length and cross-sectional area - one made of a ductile material and another of a brittle material. Now, pull these two bars until they break!! You will notice that the ductile bar elongates by a large amount before it breaks, while the brittle bar breaks suddenly on reaching its maximum strength at a relatively small elongation (Figure 2). Amongst the materials used in building construction, steel is *ductile*, while masonry and concrete are *brittle*.

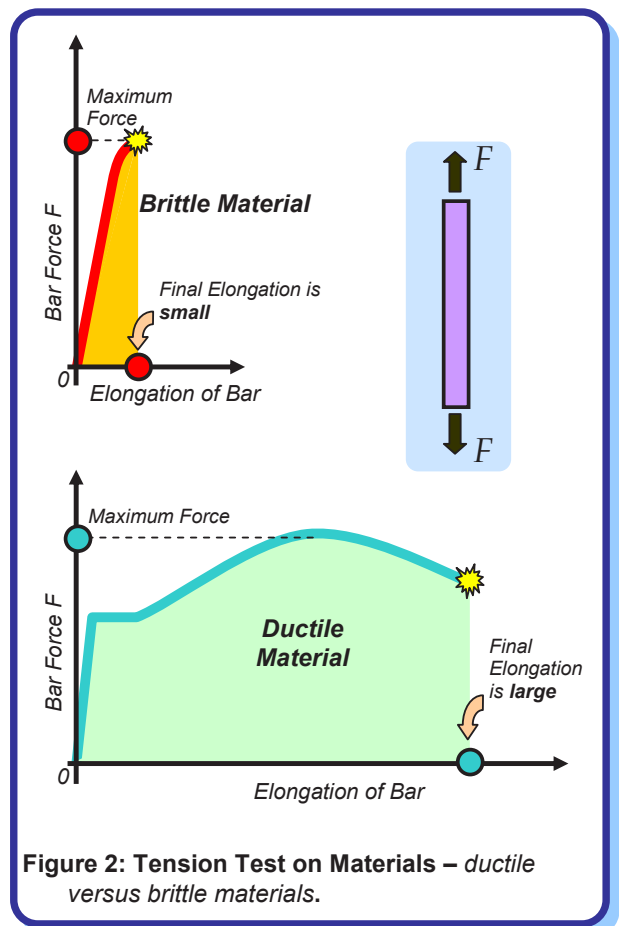

Now, let us make a chain with links made of *brittle* and *ductile* materials (Figure 3). Each of these links will fail just like the bars shown in Figure 2. Now, hold the last link at either end of the chain and apply a force F . Since the same force F is being transferred through all the links, the force in each link is the same, *i.e.*, F . As more and more force is applied, eventually the chain will break when the *weakest link* in it breaks. If the ductile link is the *weak* one (*i.e.*, its capacity to take load is less), then the chain will show large final elongation. Instead, if the brittle link is the weak one, then the chain will fail suddenly and show small final elongation. Therefore, if we want to have such a *ductile* chain, we have to make the ductile link to be the *weakest* link.

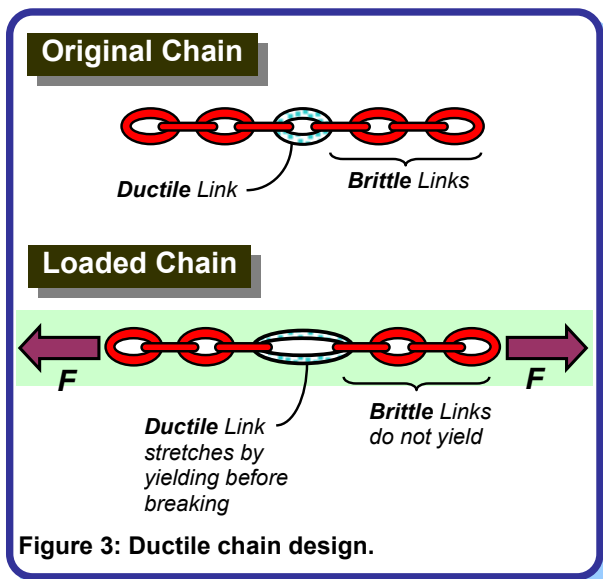

Figure 3: Ductile chain design.

Earthquake-Resistant Design of Buildings

Buildings should be designed like the ductile chain. For example, consider the common urban residential apartment construction - the multi-storey building made of reinforced concrete. It consists of horizontal and vertical members, namely *beams* and *columns*. The seismic inertia forces generated at its floor levels are transferred through the various *beams* and *columns* to the ground. The correct building components need to be made ductile. The failure of a column can affect the stability of the whole building, but the failure of a beam causes localized effect. Therefore, it is better to make *beams* to be the ductile weak links than *columns*. This method of designing RC buildings is called the *strong-column weak-beam* design method (Figure 4).

By using the *routine* design codes (meant for design against non-earthquake effects), designers may not be able to achieve a ductile structure. Special design provisions are required to help designers improve the ductility of the structure. Such provisions are usually put together in the form of a special *seismic* design code, *e.g.*, IS:13920-1993 for RC structures. These codes also ensure that adequate ductility is provided in the members where damage is expected.

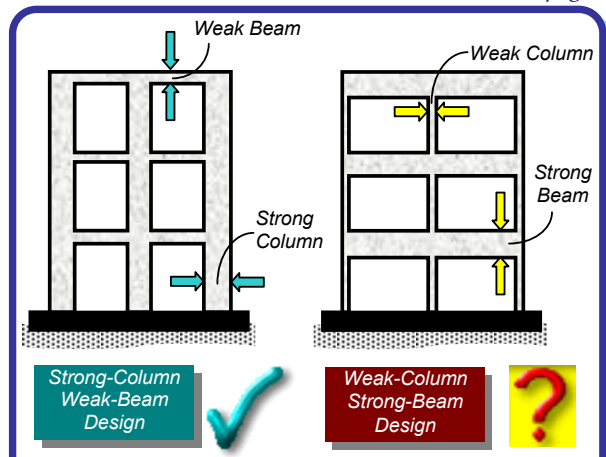

Figure 4: Reinforced Concrete Building Design: the beams must be the weakest links and not the columns – this can be achieved by appropriately sizing the members and providing correct amount of steel reinforcement in them.

Quality Control in Construction

The capacity design concept in earthquake-resistant design of buildings will fail if the strengths of the brittle links fall below their minimum assured values. The strength of brittle construction materials, like masonry and concrete, is highly sensitive to the quality of construction materials, workmanship, supervision, and construction methods. Similarly, special care is needed in construction to ensure that the elements meant to be ductile are indeed provided with features that give adequate ductility. Thus, strict adherence to prescribed standards of construction materials and construction processes is essential in assuring an earthquake-resistant building. Regular testing of construction materials at qualified laboratories (at site or away), periodic training of workmen at professional training houses, and on-site evaluation of the technical work are elements of good quality control.

Resource Material

Paulay,T., and Priestley,M.J.N., (1992), *Seismic Design of Reinforced Concrete Buildings and Masonry*, John Wiley, USA.
Mazzolani,F.M., and Piluso,V., (1996), *Theory and Design of Seismic-Resistant Steel Frames*, E&FN Spon, UK.

Next Upcoming Tip

How flexibility of buildings affects their earthquake response?

Authored by:

C.V.R.Murty
Indian Institute of Technology Kanpur
Kanpur, India

Sponsored by:

Building Materials and Technology Promotion
Council, New Delhi, India

This release is a property of IIT Kanpur and BMTPC New Delhi. It may be reproduced without changing its contents and with due acknowledgement.

Suggestions/comments may be sent to: eqtips@iitk.ac.in
To see previous IITK-BMTPC Earthquake Tips, visit www.nicee.org

December 2002

How Flexibility of Buildings Affects their Earthquake Response?

Oscillations of Flexible Buildings

When the ground shakes, the base of a building moves with the ground, and the building swings back-and-forth. If the building were rigid, then every point in it would move by the same amount as the ground. But, most buildings are flexible, and different parts move back-and-forth by different amounts.

Take a fat coir rope and tie one end of it to the roof of a building and its other end to a motorized vehicle (say a tractor). Next, start the tractor and pull the building; it will move in the direction of pull (Figure 1a). For the same amount of pull force, the movement is larger for a more flexible building. Now, cut the rope! The building will oscillate back-and-forth horizontally and after some time come back to the original position (Figure 1b); these oscillations are periodic. The time taken (*in seconds*) for each complete cycle of oscillation (*i.e.*, one complete *back-and-forth* motion) is the same and is called *Fundamental Natural Period T* of the building. Value of *T* depends on the building flexibility and mass; more the flexibility, the longer is the *T*, and more the mass, the longer is the *T*. In general, taller buildings are more flexible and have larger mass, and therefore have a longer *T*. On the contrary, low- to medium-rise buildings generally have shorter *T* (less than 0.4 sec).

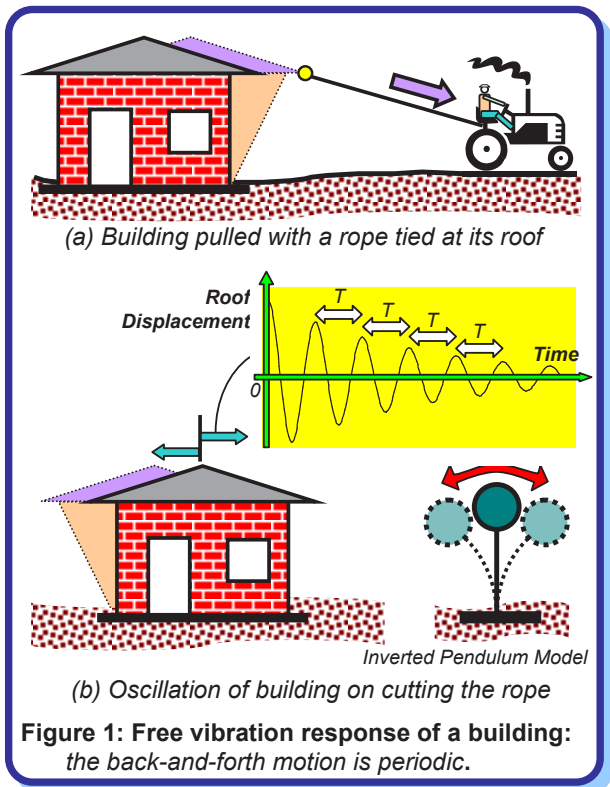

Fundamental natural period *T* is an inherent property of a building. Any alterations made to the building will change its *T*. Fundamental natural periods *T* of normal single storey to 20 storey buildings are usually in the range 0.05-2.00 sec. Some examples of natural periods of different structures are shown in Figure 2.

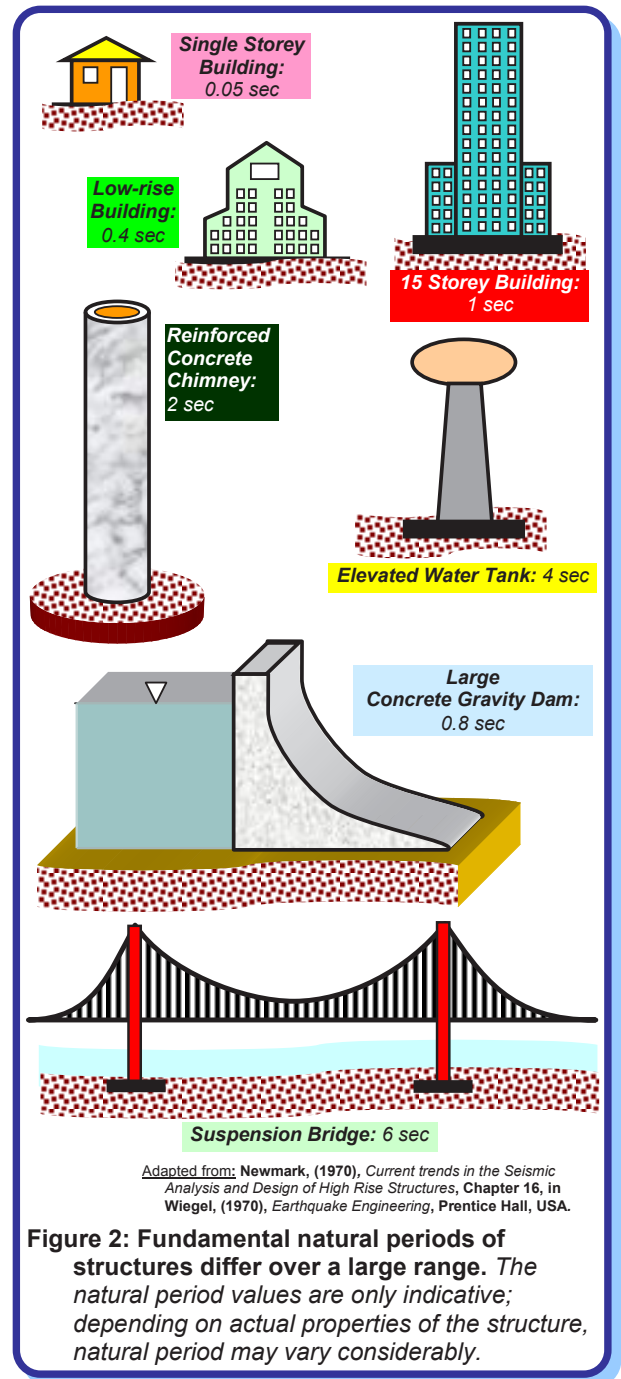

Importance of Flexibility

The ground shaking during an earthquake contains a mixture of many sinusoidal waves of different frequencies, ranging from short to long periods (Figure 3). The time taken by the wave to complete one cycle of motion is called *period of the earthquake wave*. In general, earthquake shaking of the ground has waves whose periods vary in the range 0.03-33sec. Even within this range, some earthquake waves are stronger than the others. Intensity of earthquake waves at a particular building location depends on a number of factors, including the *magnitude* of the earthquake, the *epicentral distance*, and the type of ground that the earthquake waves travelled through before reaching the location of interest.

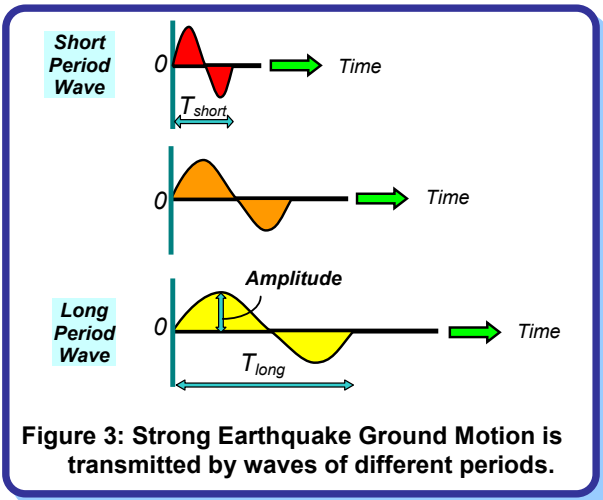

Figure 3: Strong Earthquake Ground Motion is transmitted by waves of different periods.

In a typical city, there are buildings of many different sizes and shapes. One way of categorizing them is by their *fundamental natural period T*. The ground motion under these buildings varies across the city (Figure 4a). If the ground is shaken back-and-forth by earthquake waves that have short periods, then *short period buildings* will have large response. Similarly, if the earthquake ground motion has long period waves, then *long period buildings* will have larger response. Thus, depending on the value of *T* of the buildings and on the characteristics of earthquake ground motion (*i.e.*, the periods and amplitude of the earthquake waves), some buildings will be shaken more than the others.

During the 1967 Caracas earthquake in South America, the response of buildings was found to depend on the thickness of soil under the buildings. Figure 4b shows that for buildings 3-5 storeys tall, the damage intensity was higher in areas with underlying soil cover of around 40-60m thick, but was minimal in areas with larger thickness of soil cover. On the other hand, the damage intensity was just the reverse in the case of 10-14 storey buildings; the damage intensity was more when the soil cover was in the range 150-300m, and small for lower thickness of soil cover. Here, the soil layer under the building plays the role of a filter, allowing some ground waves to pass through and filtering the rest.

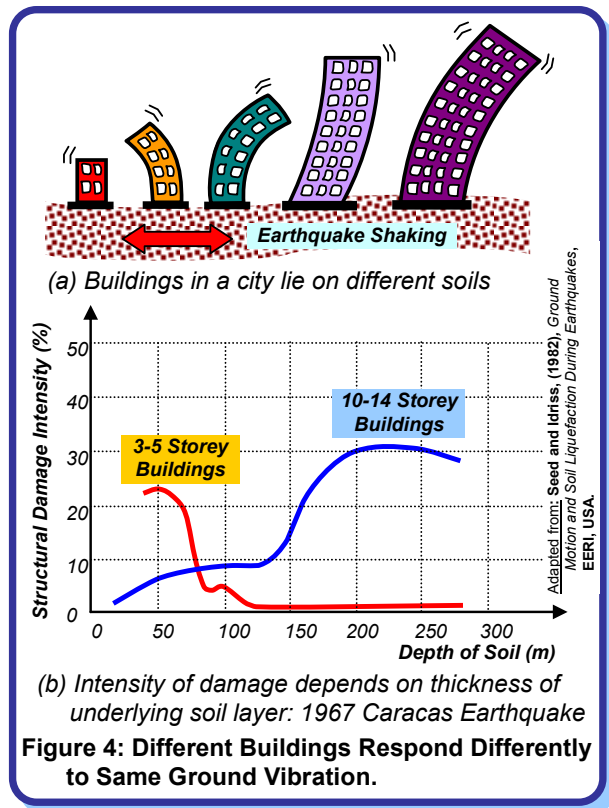

Figure 4: Different Buildings Respond Differently to Same Ground Vibration.

Flexible buildings undergo larger relative horizontal displacements, which may result in damage to various nonstructural building components and the contents. For example, some items in buildings, like glass windows, cannot take large lateral movements, and are therefore damaged severely or crushed. Unsecured shelves might topple, especially at upper stories of multi-storey buildings. These damages may not affect safety of buildings, but may cause economic losses, injuries and panic among its residents.

Related IITK - BMTPC Tip

- IITK-BMTPC Earthquake Tip 2: How the Ground Shakes?
- IITK-BMTPC Earthquake Tip 5: What are the Seismic Effects on Structures?

Resource Material

Wiegel,R., (1970), *Earthquake Engineering*, Prentice Hall Inc., USA.
 Chopra,A.K., (1980), *Dynamics of Structures - A Primer*, Earthquake Engineering Research Institute, USA.

Next Upcoming Tip

What are the Indian Seismic Codes?

Authored by:
 C.V.R.Murty
 Indian Institute of Technology Kanpur
 Kanpur, India
Sponsored by:
 Building Materials and Technology Promotion
 Council, New Delhi, India

This release is a property of IIT Kanpur and BMTPC New Delhi. It may be reproduced without changing its contents and with due acknowledgement. Suggestions/comments may be sent to: egtips@iitk.ac.in. Visit www.nicee.org or www.bmtpc.org to see previous IITK-BMTPC Earthquake Tips.

What are the Indian Seismic Codes?

Importance of Seismic Design Codes

Ground vibrations during earthquakes cause forces and deformations in structures. Structures need to be designed to withstand such forces and deformations. Seismic codes help to improve the behaviour of structures so that they may withstand the earthquake effects without significant loss of life and property. Countries around the world have procedures outlined in seismic codes to help design engineers in the planning, designing, detailing and constructing of structures. An earthquake-resistant building has four *virtues* in it, namely:

- Good Structural Configuration:** Its size, shape and structural system carrying loads are such that they ensure a direct and smooth flow of inertia forces to the ground.
- Lateral Strength:** The maximum lateral (horizontal) force that it can resist is such that the damage induced in it does not result in collapse.
- Adequate Stiffness:** Its lateral load resisting system is such that the earthquake-induced deformations in it do not damage its contents under low-to-moderate shaking.
- Good Ductility:** Its capacity to undergo large deformations under severe earthquake shaking even after yielding, is improved by favourable design and detailing strategies.

Seismic codes cover all these aspects.

Indian Seismic Codes

Seismic codes are unique to a particular region or country. They take into account the local seismology, accepted level of seismic risk, building typologies, and materials and methods used in construction. Further, they are indicative of the level of progress a country has made in the field of earthquake engineering.

The first formal seismic code in India, namely IS 1893, was published in 1962. Today, the Bureau of Indian Standards (BIS) has the following seismic codes: IS 1893 (Part I), 2002, *Indian Standard Criteria for Earthquake Resistant Design of Structures* (5th Revision) IS 4326, 1993, *Indian Standard Code of Practice for Earthquake Resistant Design and Construction of Buildings* (2nd Revision) IS 13827, 1993, *Indian Standard Guidelines for Improving Earthquake Resistance of Earthen Buildings* IS 13828, 1993, *Indian Standard Guidelines for Improving Earthquake Resistance of Low Strength Masonry Buildings* IS 13920, 1993, *Indian Standard Code of Practice for Ductile Detailing of Reinforced Concrete Structures Subjected to Seismic Forces*

IS 13935, 1993, *Indian Standard Guidelines for Repair and Seismic Strengthening of Buildings*

The regulations in these standards do not ensure that structures suffer *no damage* during earthquake of *all magnitudes*. But, to the extent possible, they ensure that structures are able to respond to earthquake shakings of *moderate intensities* without *structural damage* and of *heavy intensities* without *total collapse*.

IS 1893

IS 1893 is the main code that provides the seismic zone map (Figure 1) and specifies seismic design force. This force depends on the mass and seismic coefficient of the structure; the latter in turn depends on properties like seismic zone in which structure lies, importance of the structure, its stiffness, the soil on which it rests, and its ductility. For example, a building in Bhuj will have 2.25 times the seismic design force of an identical building in Bombay. Similarly, the seismic coefficient for a single-storey building may have 2.5 times that of a 15-storey building.

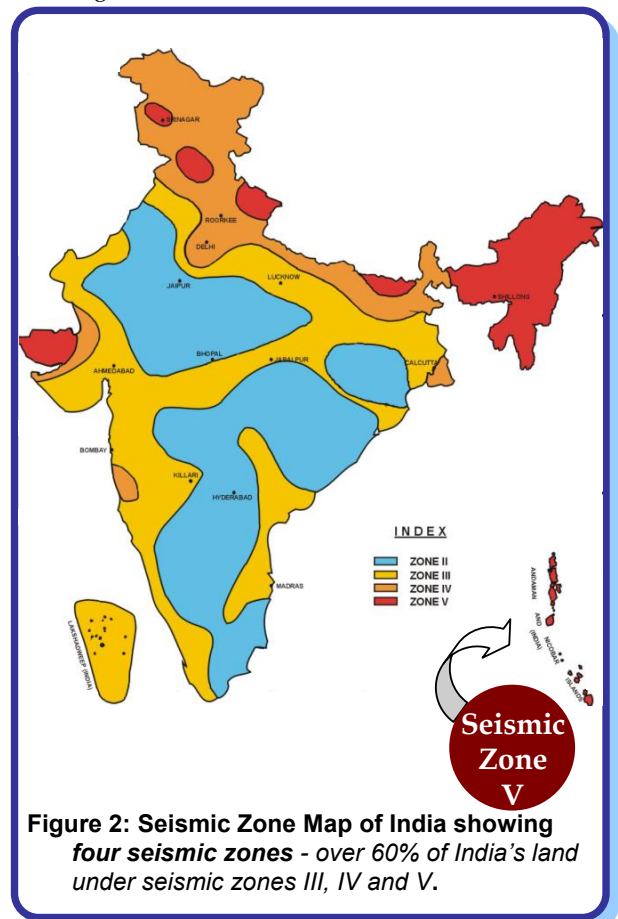

Figure 2: Seismic Zone Map of India showing four seismic zones - over 60% of India's land under seismic zones III, IV and V.

What are the Indian Seismic Codes?

The revised 2002 edition, Part 1 of IS1893, contains provisions that are general in nature and those applicable for buildings. The other four parts of IS 1893 will cover: Liquid-Retaining Tanks, both elevated and ground supported (*Part 2*); Bridges and Retaining Walls (*Part 3*); Industrial Structures including Stack-Like Structures (*Part 4*); and Dams and Embankments (*Part 5*). These four documents are under preparation. In contrast, the 1984 edition of IS1893 had provisions for all the above structures in a single document.

Provisions for Bridges

Seismic design of bridges in India is covered in three codes, namely *IS 1893 (1984)* from the BIS, *IRC 6 (2000)* from the Indian Roads Congress, and *Bridge Rules (1964)* from the Ministry of Railways. All highway bridges are required to comply with IRC 6, and all railway bridges with Bridge Rules. These three codes are conceptually the same, even though there are some differences in their implementation. After the 2001 Bhuj earthquake, in 2002, the IRC released interim provisions that make significant improvements to the IRC6 (2000) seismic provisions.

IS 4326, 1993

This code covers general principles for earthquake resistant buildings. Selection of materials and *special features* of design and construction are dealt with for the following types of buildings: timber constructions, masonry constructions using rectangular masonry units, and buildings with prefabricated reinforced concrete roofing/flooring elements.

IS 13827, 1993 and IS 13828, 1993

Guidelines in IS 13827 deal with empirical design and construction aspects for *improving* earthquake-resistance of *earthen houses*, and those in IS 13828 with general principles of design and special construction features for *improving* earthquake resistance of buildings of *low-strength masonry*. This masonry includes burnt clay brick or stone masonry in weak mortars, like clay-mud. These standards are applicable in seismic zones III, IV and V. Constructions based on them are termed non-engineered, and are not totally free from collapse under seismic shaking intensities VIII (MMI) and higher. Inclusion of features mentioned in these guidelines may only enhance the seismic resistance and reduce chances of collapse.

IS 13920, 1993

In India, reinforced concrete structures are designed and detailed as per the Indian Code IS 456 (2002). However, structures located in *high seismic regions* require ductile design and detailing. Provisions for the ductile detailing of *monolithic* reinforced concrete frame and shear wall structures are specified in IS 13920 (1993). After the 2001 Bhuj earthquake, this code has been made mandatory for all structures in zones III, IV and V. Similar provisions for seismic design and ductile detailing of steel structures are not yet available in the Indian codes.

IS 13935, 1993

These guidelines cover general principles of seismic strengthening, selection of materials, and techniques for repair/seismic strengthening of masonry and wooden buildings. The code provides a brief coverage for *individual reinforced concrete members* in such buildings, but does not cover *reinforced concrete frame* or *shear wall buildings* as a whole. Some guidelines are also laid down for *non-structural* and *architectural components* of buildings.

In Closure...

Countries with a history of earthquakes have well developed earthquake codes. Thus, countries like Japan, New Zealand and the United States of America, have detailed seismic code provisions. Development of building codes in India started rather early. Today, India has a fairly good range of seismic codes covering a variety of structures, ranging from mud or low-strength masonry houses to modern buildings. However, the key to ensuring earthquake safety lies in having a robust mechanism that enforces and implements these design code provisions in actual constructions.

Related IITK-BMTPC Tip

Tip 4: Where are the seismic zones in India?

Tip 8: What is the seismic design philosophy of buildings?

Tip 9: How to make buildings ductile for good seismic performance?

Tip 10: How flexibility of buildings affects their earthquake response?

Resource Material

BMTPC, (2000), *Guidelines: Improving Earthquake Resistance of Housing, Building Materials and Technology Promotion Council, New Delhi.*

Bridge Rules, (1964), Rules Specifying the Loads for the Design of Super-Structure and Sub-Structure of Bridges and for Assessment of the Strength of Existing Bridges, Government of India, Ministry of Railways (Railway Board).

IRC 6, (2000), *Standard Specifications and Code of Practice for Road Bridges - Section II: Loads and Stresses, Indian Roads Congress, New Delhi.*

IS 456, (2000), *Indian Standard Code of Practice for Plain and Reinforced Concrete, Bureau of Indian Standards, New Delhi.*

SP 22 (S&T), (1982), *Explanatory Handbook on Codes for Earthquakes Engineering - IS 1893:1975 and IS 4326:1976, Bureau of Indian Standards, New Delhi.*

Next Upcoming Tip

How do masonry buildings behave during earthquakes?

Authored by:

C.V.R.Murty

Indian Institute of Technology Kanpur
Kanpur, India

Sponsored by:

Building Materials and Technology Promotion
Council, New Delhi, India

This release is a property of IIT Kanpur and BMTPC New Delhi. It may be reproduced without changing its contents and with due acknowledgement. Suggestions/comments may be sent to: egtips@iitk.ac.in. Visit www.nicee.org or www.bmtpc.org, to see previous IITK-BMTPC Earthquake Tips.

February 2003

How do brick masonry houses behave during earthquakes?

Behaviour of Brick Masonry Walls

Masonry buildings are brittle structures and one of the most vulnerable of the entire building stock under strong earthquake shaking. The large number of human fatalities in such constructions during the past earthquakes in India corroborates this. Thus, it is very important to improve the seismic behaviour of masonry buildings. A number of earthquake-resistant features can be introduced to achieve this objective.

Ground vibrations during earthquakes cause inertia forces at locations of mass in the building. These forces travel through the roof and walls to the foundation. The main emphasis is on ensuring that these forces reach the ground without causing major damage or collapse. Of the three components of a masonry building (*roof, wall and foundation*) (Figure 1a), the walls are most vulnerable to damage caused

by horizontal forces due to earthquake. A wall topples down easily if pushed horizontally at the top in a direction perpendicular to its plane (termed *weak direction*), but offers much greater resistance if pushed along its length (termed *strong direction*) (Figure 1b).

The ground shakes simultaneously in the vertical and two horizontal directions during earthquakes (IITK-BMTPC Earthquake Tip 5). However, the horizontal vibrations are the most damaging to normal masonry buildings. Horizontal inertia force developed at the roof transfers to the walls acting either in the weak or in the strong direction. If all the walls are not tied together like a box, the walls loaded in their weak direction tend to topple (Figure 2a).

To ensure good seismic performance, all walls must be joined properly to the adjacent walls. In this way, walls loaded in their weak direction can *take advantage* of the good lateral resistance offered by walls loaded in their strong direction (Figure 2b). Further, walls also need to be tied to the roof and foundation to preserve their overall integrity.

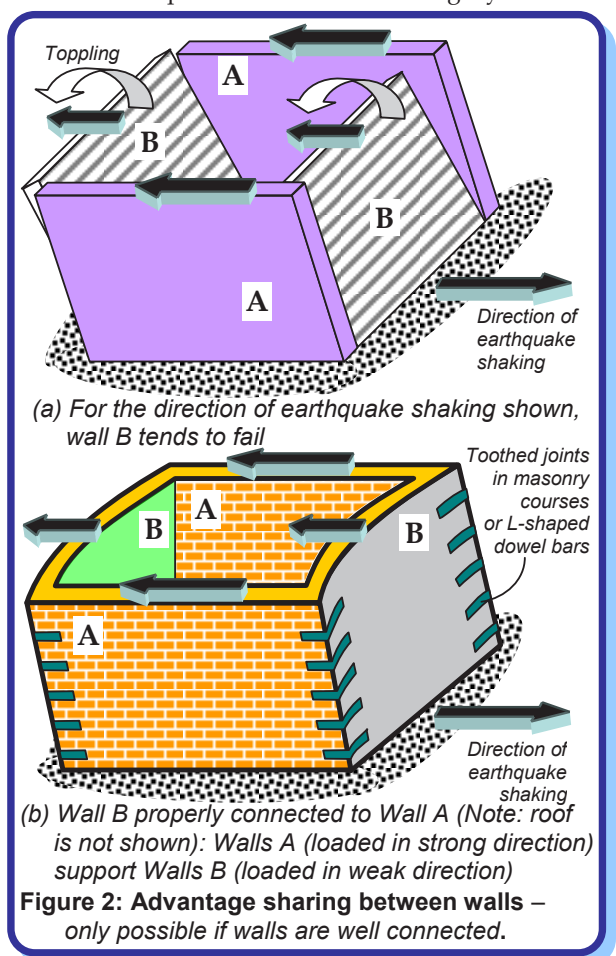
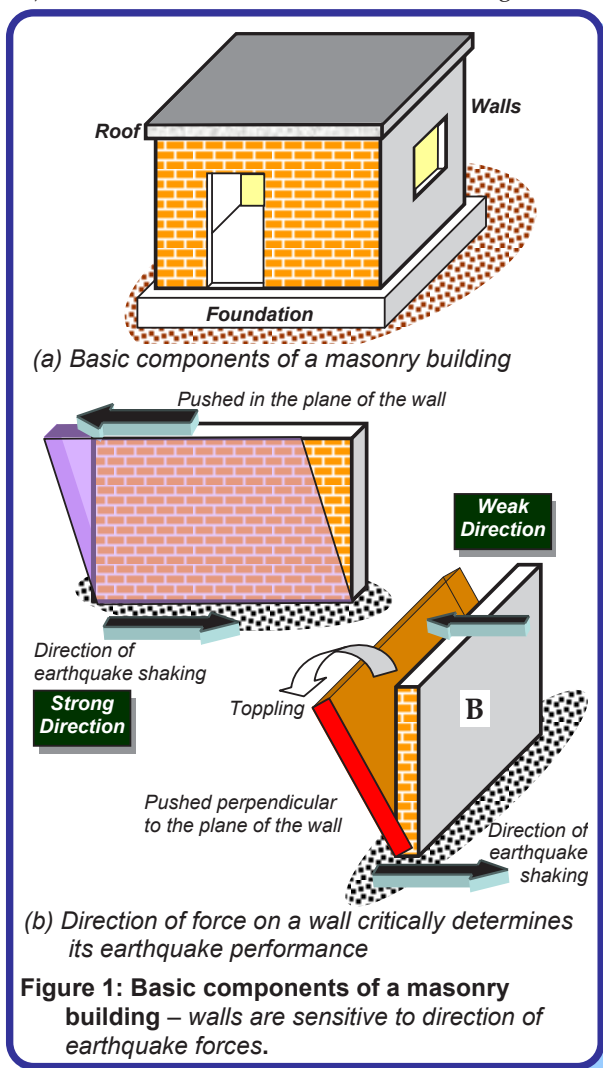

How to Improve Behaviour of Masonry Walls

Masonry walls are slender because of their small thickness compared to their height and length. A simple way of making these walls behave well during earthquake shaking is by making them act together as a box along with the roof at the top and with the foundation at the bottom. A number of construction aspects are required to ensure this box action. Firstly, connections between the walls should be good. This can be achieved by (a) ensuring good interlocking of the masonry courses at the junctions, and (b) employing horizontal bands at various levels, particularly at the lintel level. Secondly, the sizes of door and window openings need to be kept small. The smaller the openings, the larger is the resistance offered by the wall. Thirdly, the tendency of a wall to topple when pushed in the weak direction can be reduced by limiting its length-to-thickness and height-to-thickness ratios (Figure 3). Design codes specify limits for these ratios. A wall that is too tall or too long in comparison to its thickness, is particularly vulnerable to shaking in its weak direction (Figure 3).

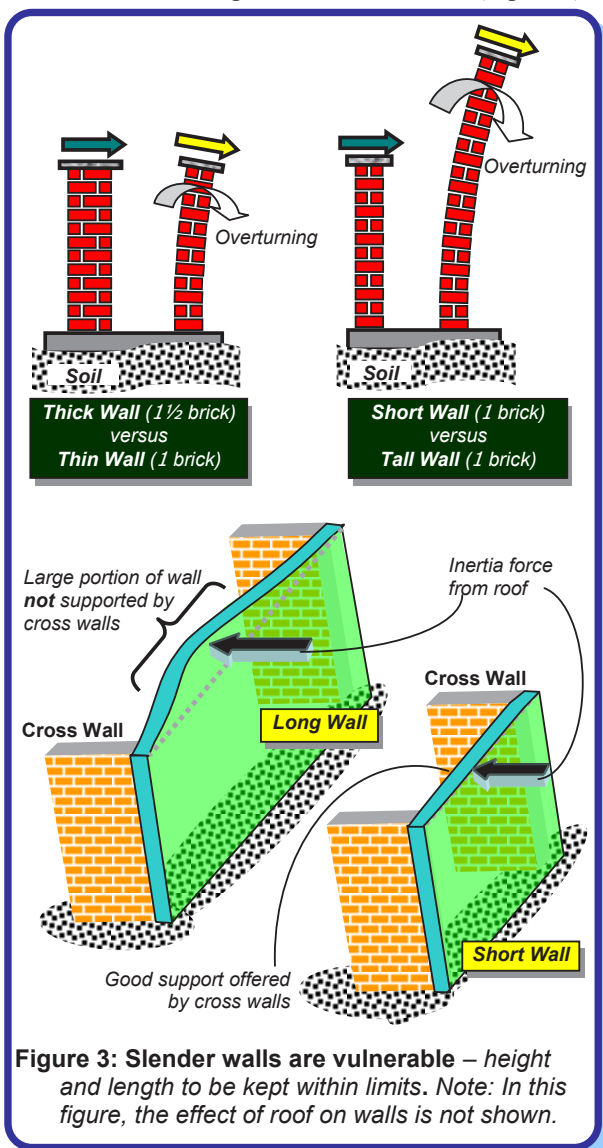

Figure 3: Slender walls are vulnerable – height and length to be kept within limits. Note: In this figure, the effect of roof on walls is not shown.

Choice and Quality of Building Materials

Earthquake performance of a masonry wall is very sensitive to the properties of its constituents, namely masonry units and mortar. The properties of these materials vary across India due to variation in raw materials and construction methods. A variety of masonry units are used in the country, e.g., clay bricks (burnt and unburnt), concrete blocks (solid and hollow), stone blocks. *Burnt clay bricks* are most commonly used. These bricks are inherently porous, and so they absorb water. Excessive porosity is detrimental to good masonry behaviour because the bricks suck away water from the adjoining mortar, which results in poor bond between brick and mortar, and in difficulty in positioning masonry units. For this reason, bricks with low porosity are to be used, and they must be soaked in water before use to minimise the amount of water drawn away from the mortar.

Various mortars are used, e.g., mud, cement-sand, or cement-sand-lime. Of these, *mud mortar* is the weakest; it crushes easily when dry, flows outward and has very low earthquake resistance. *Cement-sand mortar with lime* is the most suitable. This mortar mix provides excellent workability for laying bricks, stretches without crumbling at low earthquake shaking, and bonds well with bricks. The earthquake response of masonry walls depends on the relative strengths of brick and mortar. Bricks must be stronger than mortar. Excessive thickness of mortar is not desirable. A 10mm thick mortar layer is generally satisfactory from practical and aesthetic considerations. Indian Standards prescribe the preferred types and grades of bricks and mortars to be used in buildings in each seismic zone.

Related IITK – BMTPC Earthquake Tip

Tip 5: What are the seismic effects on structures?

Resource Material

- IS 1905, (1987), *Indian Standard Code of Practice for Structural Use of Unreinforced Masonry*, Bureau of Indian Standards, New Delhi.
- IS 4326, (1993), *Indian Standard Code of Practice for Earthquake Resistant Design and Construction of Buildings*, Bureau of Indian Standards, New Delhi.
- IS 13828, (1993), *Indian Standard Guidelines for Improving Earthquake Resistance of Low-strength Masonry Buildings*, Bureau of Indian Standards, New Delhi.
- Paulay, T., and Priestley, M.J.N., (1992), *Seismic Design of Reinforced Concrete and Masonry Buildings*, John Wiley & Sons, New York.

Next Upcoming Tip

Why should masonry houses have simple structural configuration?

Authored by:

C.V.R.Murty
Indian Institute of Technology Kanpur
Kanpur, India

Sponsored by:

Building Materials and Technology Promotion
Council, New Delhi, India

This release is a property of IIT Kanpur and BMTPC New Delhi. It may be reproduced without changing its contents and with due acknowledgement. Suggestions/comments may be sent to: egtips@iitk.ac.in. Visit www.nicee.org or www.bmtpc.org, to see previous IITK-BMTPC Earthquake Tips.

March 2003

Why should masonry buildings have simple structural configuration?

Box Action in Masonry Buildings

Brick masonry buildings have large mass and hence attract large horizontal forces during earthquake shaking. They develop numerous cracks under both compressive and tensile forces caused by earthquake shaking. The focus of *earthquake resistant* masonry building construction is to ensure that these effects are sustained without major damage or collapse. Appropriate choice of structural configuration can help achieve this.

The structural configuration of masonry buildings includes aspects like (a) overall shape and size of the building, and (b) distribution of mass and (horizontal) lateral load resisting elements across the building. Large, tall, long and unsymmetric buildings perform poorly during earthquakes (IITK-BMTPC Earthquake Tip 6). A strategy used in making them earthquake-resistant is developing good *box action* between all the elements of the building, *i.e.*, between roof, walls and foundation (Figure 1). Loosely connected roof or unduly slender walls are threats to good seismic behaviour. For example, a horizontal band introduced at the lintel level ties the walls together and helps to make them behave as a single unit.

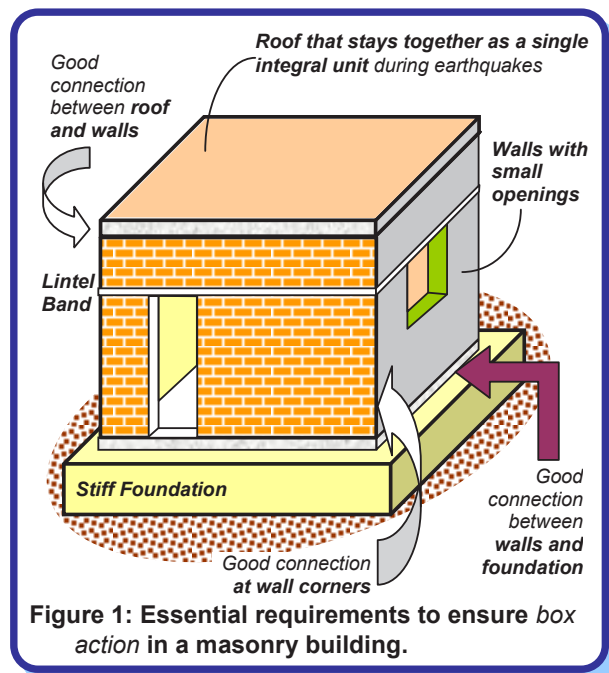

Influence of Openings

Openings are functional necessities in buildings. However, location and size of openings in walls assume significance in deciding the performance of masonry buildings in earthquakes. To understand this,

consider a four-wall system of a single storey masonry building (Figure 2). During earthquake shaking, inertia forces act in the strong direction of some walls and in the weak direction of others (See IITK-BMTPC Earthquake Tip 12). Walls shaken in the weak direction seek support from the other walls, *i.e.*, walls B1 and B2 seek support from walls A1 and A2 for shaking in the direction shown in Figure 2. To be more specific, wall B1 pulls walls A1 and A2, while wall B2 pushes against them. At the next instance, the direction of shaking could change to the horizontal direction perpendicular to that shown in Figure 2. Then, walls A and B change their roles; Walls B1 and B2 become the strong ones and A1 and A2 weak.

Thus, walls transfer loads to each other at their junctions (and through the lintel bands and roof). Hence, the masonry courses from the walls meeting at corners must have good interlocking. For this reason, openings near the wall corners are detrimental to good seismic performance. Openings too close to wall corners hamper the flow of forces from one wall to another (Figure 3). Further, large openings weaken walls from carrying the inertia forces in their own plane. Thus, it is best to keep all openings as small as possible and as far away from the corners as possible.

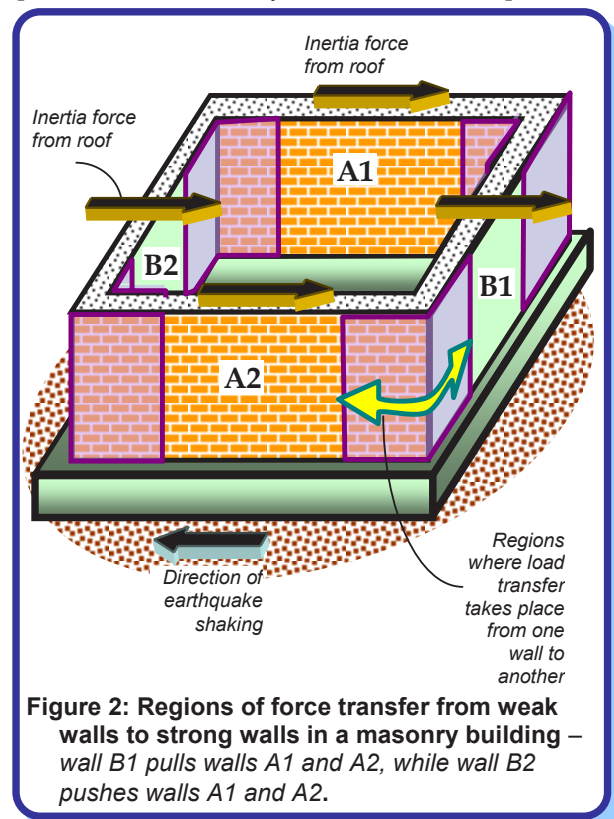

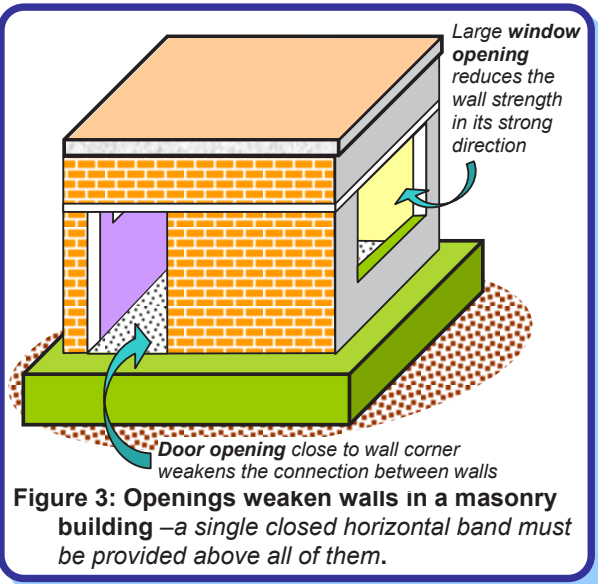

Figure 3: Openings weaken walls in a masonry building – a single closed horizontal band must be provided above all of them.

Earthquake-Resistant Features

Indian Standards suggest a number of earthquake-resistant measures to develop good *box-type* action in masonry buildings and improve their seismic performance. For instance, it is suggested that a building having horizontal projections when seen from the top, e.g., like a building with plan shapes L, T, E and Y, be separated into (almost) simple rectangular blocks in plan, each of which has simple and good earthquake behaviour (IITK-BMTPC Earthquake Tip 6). During earthquakes, separated blocks can oscillate independently and even hammer each other if they are too close. Thus, adequate gap is necessary between these different blocks of the building. The Indian Standards suggest minimum seismic separations between blocks of buildings. However, it may not be necessary to provide such separations between blocks, if horizontal projections in buildings are small, say up to ~15-20% of the length of building in that direction.

Inclined staircase slabs in masonry buildings offer another concern. An integrally connected staircase slab acts like a cross-brace between floors and transfers large horizontal forces at the roof and lower levels (Figure 4a). These are areas of potential damage in masonry buildings, if not accounted for in staircase design and construction. To overcome this, sometimes, staircases are completely separated (Figure 4b) and built on a separate reinforced concrete structure. Adequate gap is provided between the staircase tower and the masonry building to ensure that they do not pound each other during strong earthquake shaking.

Resource Material

- IS 1905, (1987), *Indian Standard Code of Practice for Structural Use of Unreinforced Masonry*, Bureau of Indian Standards, New Delhi.
- IS 42326, (1993), *Indian Standard Code of Practice for Earthquake Resistant Design and Construction of Buildings*, Bureau of Indian Standards, New Delhi.
- IS 13828, (1993), *Indian Standard Guidelines for Improving Earthquake Resistance of Low-strength Masonry Buildings*, Bureau of Indian Standards, New Delhi.
- Tomazevic, M., (1999), *Earthquake Resistant Design of Masonry Buildings*, Imperial College Press, London, UK.

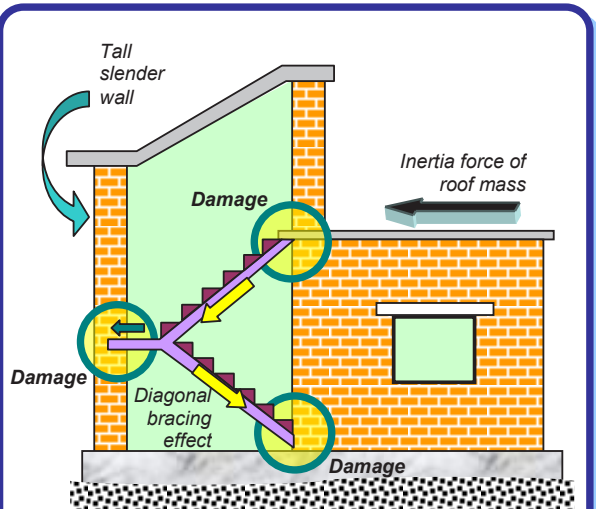

(a) Damage in building with rigidly built-in staircase

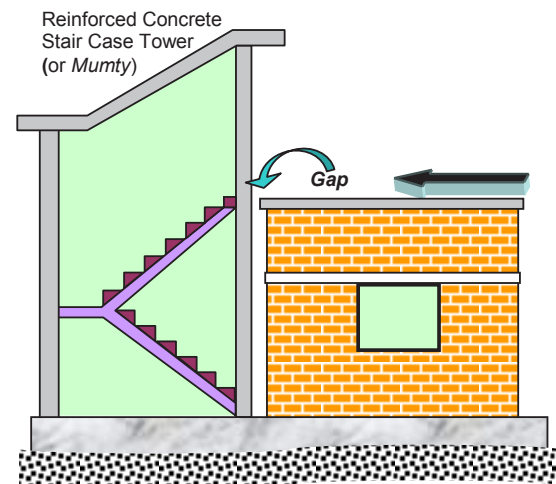

(b) Building with separated staircase

Figure 4: Earthquake-resistant detailing of staircase in masonry building – must be carefully designed and constructed.

Related IITK – BMTPC Earthquake Tip

- Tip 5: What are the seismic effects on structures?
- Tip 6: How architectural features affect buildings during earthquakes?
- Tip 12: How brick masonry houses behave during earthquakes?

Next Upcoming Tip

Why are horizontal bands necessary in masonry buildings?

Authored by:
 C.V.R.Murty
 Indian Institute of Technology Kanpur
 Kanpur, India

Sponsored by:
 Building Materials and Technology Promotion
 Council, New Delhi, India

This release is a property of IIT Kanpur and BMTPC New Delhi. It may be reproduced without changing its contents and with due acknowledgement. Suggestions/comments may be sent to: egtips@iitk.ac.in. Visit www.nicee.org or www.bmtpc.org, to see previous IITK-BMTPC Earthquake Tips.

Why are horizontal bands necessary in masonry buildings?

Role of Horizontal Bands

Horizontal bands are the most important earthquake-resistant feature in masonry buildings. The bands are provided to hold a masonry building as a single unit by tying all the walls together, and are similar to a closed belt provided around cardboard boxes. There are four types of bands in a typical masonry building, namely *gable band*, *roof band*, *lintel band* and *plinth band* (Figure 1), named after their location in the building. The lintel band is the most important of all, and needs to be provided in almost all buildings. The gable band is employed only in buildings with pitched or sloped roofs. In buildings with flat *reinforced concrete* or *reinforced brick* roofs, the roof band is not required, because the roof slab also plays the role of a band. However, in buildings with

flat timber or CGI sheet roof, roof band needs to be provided. In buildings with pitched or sloped roof, the roof band is very important. Plinth bands are primarily used when there is concern about uneven settlement of foundation soil.

The lintel band ties the walls together and creates a support for walls loaded along weak direction from walls loaded in strong direction. This band also reduces the unsupported height of the walls and thereby improves their stability in the weak direction. During the 1993 Latur earthquake (Central India), the intensity of shaking in Killari village was IX on MSK scale. Most masonry houses sustained partial or complete collapse (Figure 2a). On the other hand, there was one masonry building in the village, which had a lintel band and it sustained the shaking very well with hardly any damage (Figure 2b).

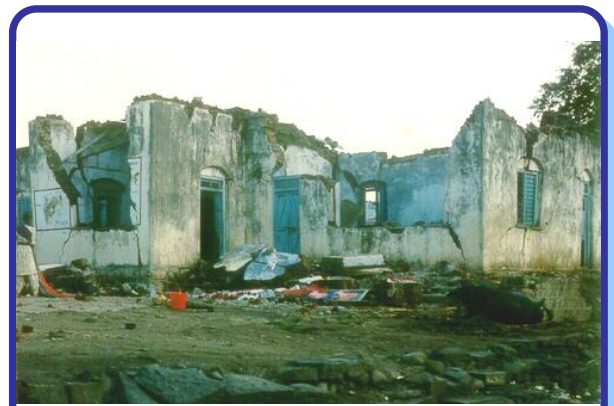
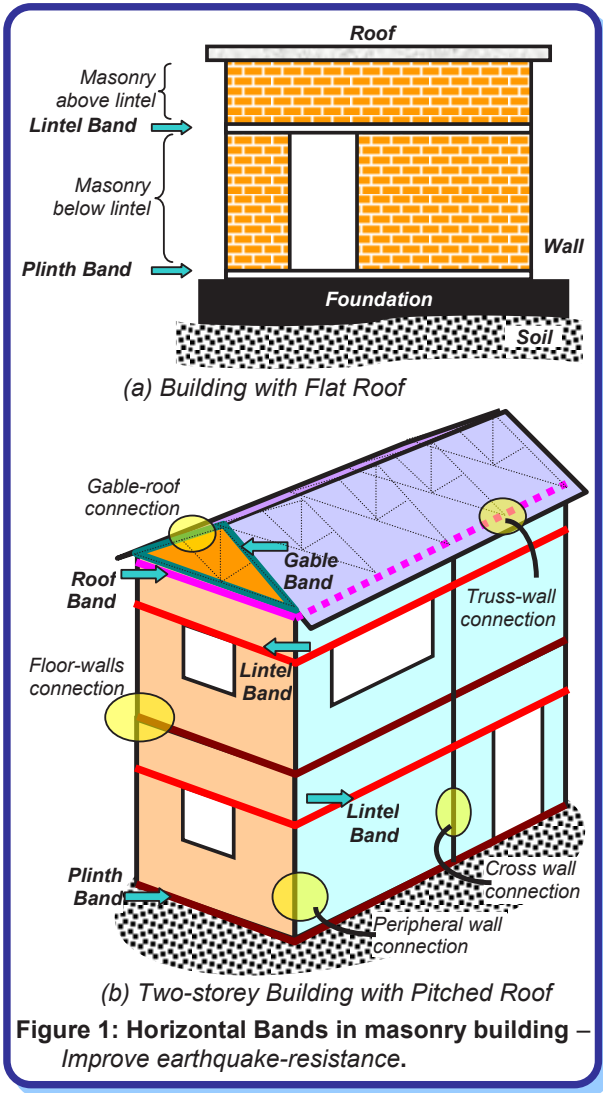

(a) Building with no horizontal lintel band: collapse of roof and walls



(b) A building with horizontal lintel band in Killari village: no damage

Figure 2: The 1993 Latur Earthquake (Central India) - one masonry house in Killari village had horizontal lintel band and sustained the shaking without damage.

Design of Lintel Bands

During earthquake shaking, the lintel band undergoes bending and pulling actions (Figure 3). To resist these actions, the construction of lintel band requires special attention. Bands can be made of wood (including bamboo splits) or of reinforced concrete (RC) (Figure 4); the RC bands are the best. The straight lengths of the band must be properly connected at the wall corners. This will allow the band to support walls loaded in their weak direction by walls loaded in their strong direction. Small lengths of wood spacers (in wooden bands) or steel links (in RC bands) are used to make the straight lengths of wood runners or steel bars act together. In wooden bands, proper nailing of straight lengths with spacers is important. Likewise, in RC bands, adequate anchoring of steel links with steel bars is necessary.

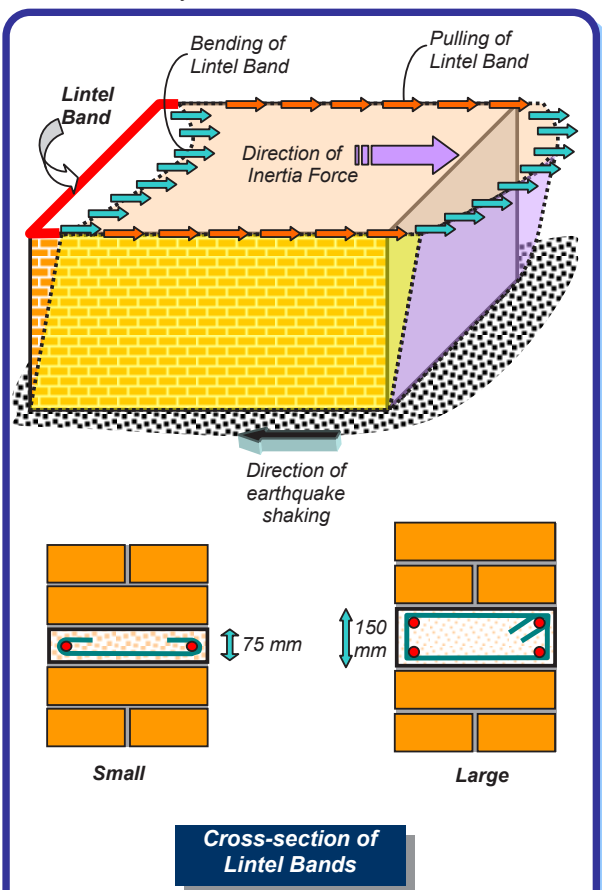

Figure 3: Bending and pulling in lintel bands – Bands must be capable of resisting these.

Indian Standards

The Indian Standards IS:4326-1993 and IS:13828 (1993) provide sizes and details of the bands. When wooden bands are used, the cross-section of runners is to be at least 75mm×38mm and of spacers at least 50mm×30mm. When RC bands are used, the minimum thickness is 75mm, and at least two bars of 8mm diameter are required, tied across with steel links of at least 6mm diameter at a spacing of 150 mm centers.

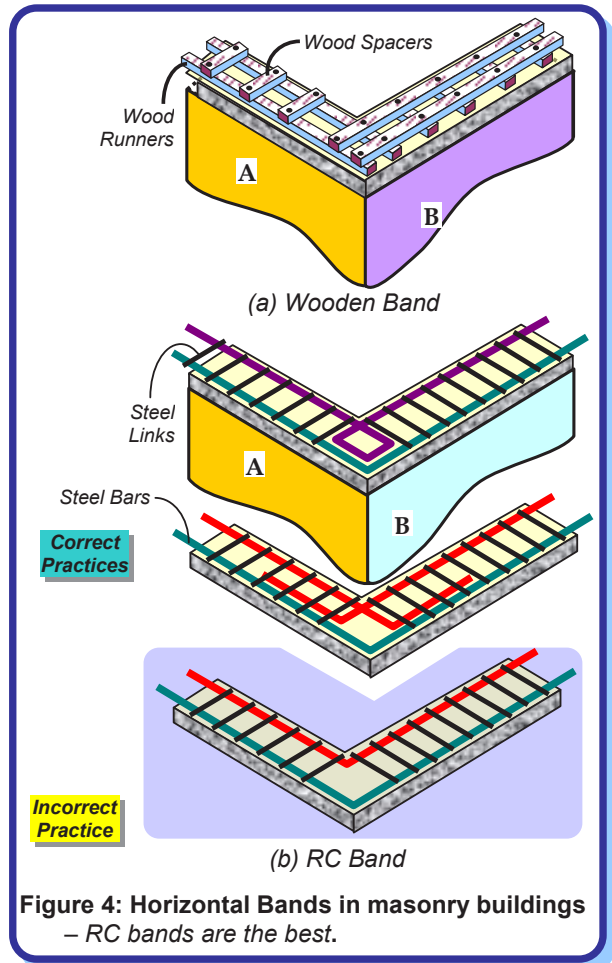

Figure 4: Horizontal Bands in masonry buildings – RC bands are the best.

Related IITK – BMTPC Earthquake Tip

- Tip 5: What are the seismic effects on structures?
- Tip12: How brick masonry houses behave during earthquakes?
- Tip13: Why masonry buildings should have simple structural configuration?

Resource Material

- IAEE, (1986), *Guidelines for Earthquake Resistant Non-Engineered Construction*, International Association for Earthquake Engineering, Tokyo, available on www.nicee.org.
- IS 4326, (1993), *Indian Standard Code of Practice for Earthquake Resistant Design and Construction of Buildings*, Bureau of Indian Standards, New Delhi.
- IS 13828, (1993), *Indian Standard Guidelines for Improving Earthquake Resistance of Low-strength Masonry Buildings*, Bureau of Indian Standards, New Delhi.

Next Upcoming Tip

Why is vertical reinforcement required in masonry buildings?

Authored by:
 C.V.R.Murty
 Indian Institute of Technology Kanpur
 Kanpur, India
Sponsored by:
 Building Materials and Technology Promotion
 Council, New Delhi, India

This release is a property of IIT Kanpur and BMTPC New Delhi. It may be reproduced without changing its contents and with due acknowledgement. Suggestions/comments may be sent to: egtips@iitk.ac.in. Visit www.nicee.org or www.bmtpc.org, to see previous IITK-BMTPC Earthquake Tips.



Why is vertical reinforcement required in masonry buildings?

Response of Masonry Walls

Horizontal bands are provided in masonry buildings to improve their earthquake performance. These bands include *plinth band*, *lintel band* and *roof band*. Even if horizontal bands are provided, masonry buildings are weakened by the openings in their walls (Figure 1). During earthquake shaking, the masonry walls get grouped into three sub-units, namely *spandrel masonry*, *wall pier masonry* and *sill masonry*.

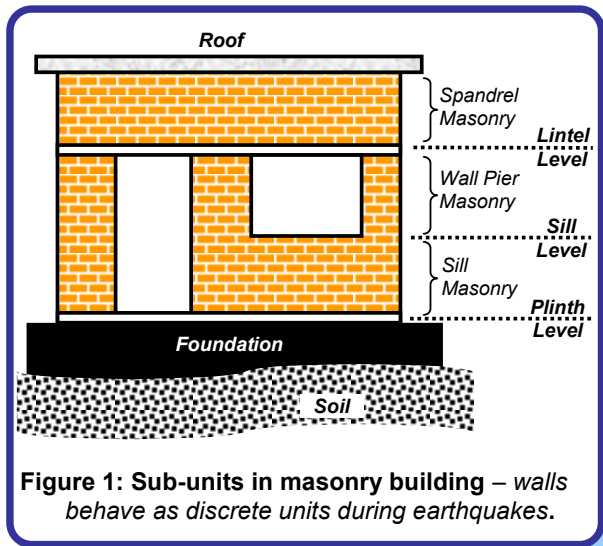

Figure 1: Sub-units in masonry building – walls behave as discrete units during earthquakes.

Consider a hipped roof building with two window openings and one door opening in a wall (Figure 2a). It has *lintel* and *plinth bands*. Since the roof is a hipped one, a *roof band* is also provided. When the ground shakes, the inertia force causes the small-sized masonry *wall piers* to disconnect from the masonry above and below. These masonry sub-units rock back and forth, developing contact only at the opposite diagonals (Figure 2b). The rocking of a masonry pier can crush the masonry at the corners. Rocking is possible when masonry piers are slender, and when weight of the structure above is small. Otherwise, the piers are more likely to develop diagonal (*X-type*) shear cracking (Figure 2c); this is the most common failure type in masonry buildings.

In un-reinforced masonry buildings (Figure 3), the cross-section area of the masonry wall reduces at the opening. During strong earthquake shaking, the building may *slide* just under the roof, below the lintel band or at the sill level. Sometimes, the building may also slide at the plinth level. The exact location of sliding depends on numerous factors including building weight, the earthquake-induced inertia force, the area of openings, and type of doorframes used.

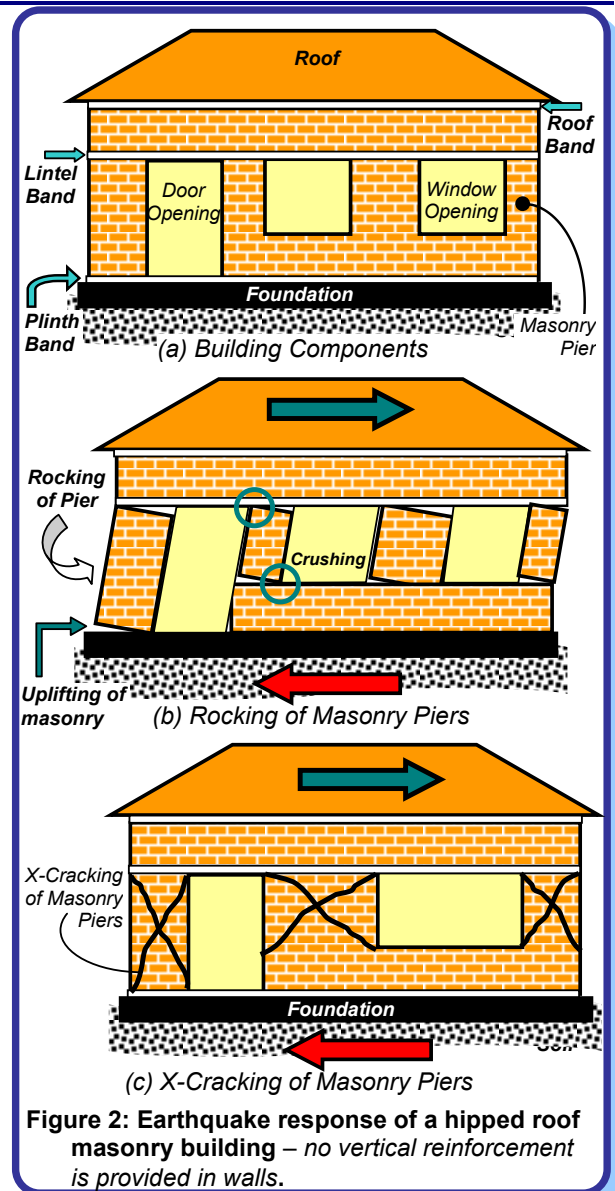

Figure 2: Earthquake response of a hipped roof masonry building – no vertical reinforcement is provided in walls.

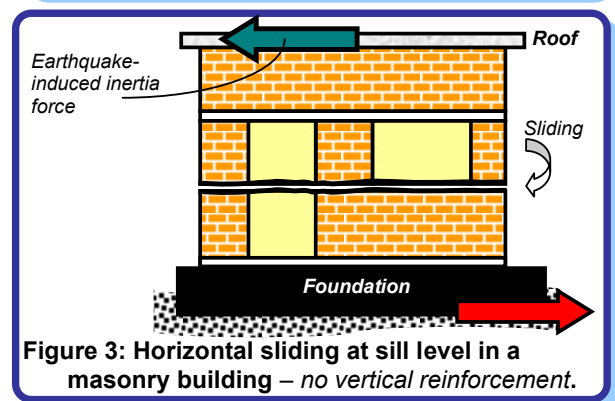
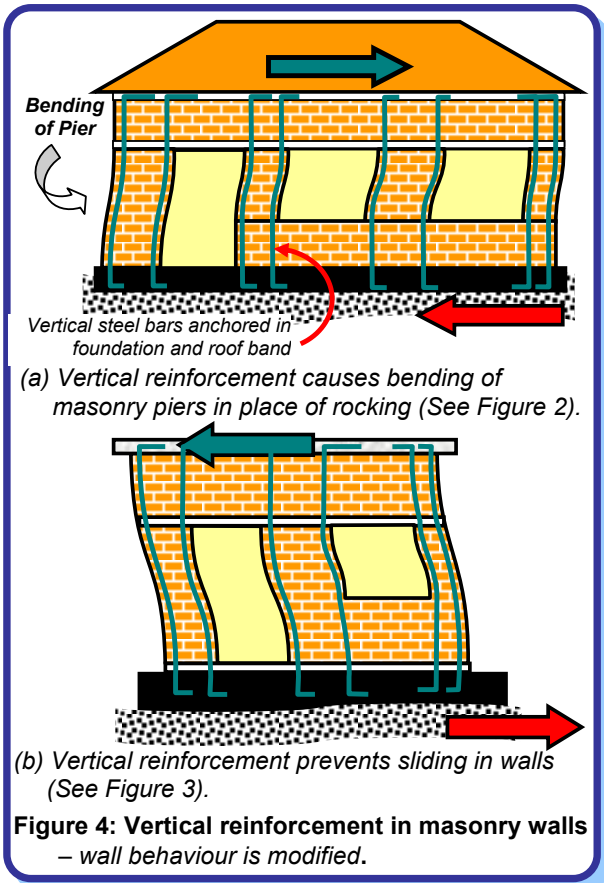

Figure 3: Horizontal sliding at sill level in a masonry building – no vertical reinforcement.

How Vertical Reinforcement Helps

Embedding vertical reinforcement bars in the edges of the wall piers and anchoring them in the foundation at the bottom and in the roof band at the top (Figure 4), forces the slender masonry piers to undergo *bending* instead of *rocking*. In wider wall piers, the vertical bars enhance their capability to resist horizontal earthquake forces and delay the X-cracking. Adequate cross-sectional area of these vertical bars prevents the bar from yielding in tension. Further, the vertical bars also help protect the wall from sliding as well as from collapsing in the weak direction.



Protection of Openings in Walls

Sliding failure mentioned above is rare, even in unconfined masonry buildings. However, the most common damage, observed after an earthquake, is diagonal X-cracking of wall piers, and also inclined cracks at the corners of door and window openings. When a wall with an opening deforms during earthquake shaking, the shape of the opening distorts and becomes more like a *rhombus* - two opposite corners move away and the other two come closer. Under this type of deformation, the corners that come closer develop cracks (Figure 5a). The cracks are bigger when the opening sizes are larger. Steel bars provided in the wall masonry all around the openings restrict these cracks at the corners (Figure 5b). In summary, lintel and sill bands above and below openings, and vertical reinforcement adjacent to vertical edges, provide protection against this type of damage.

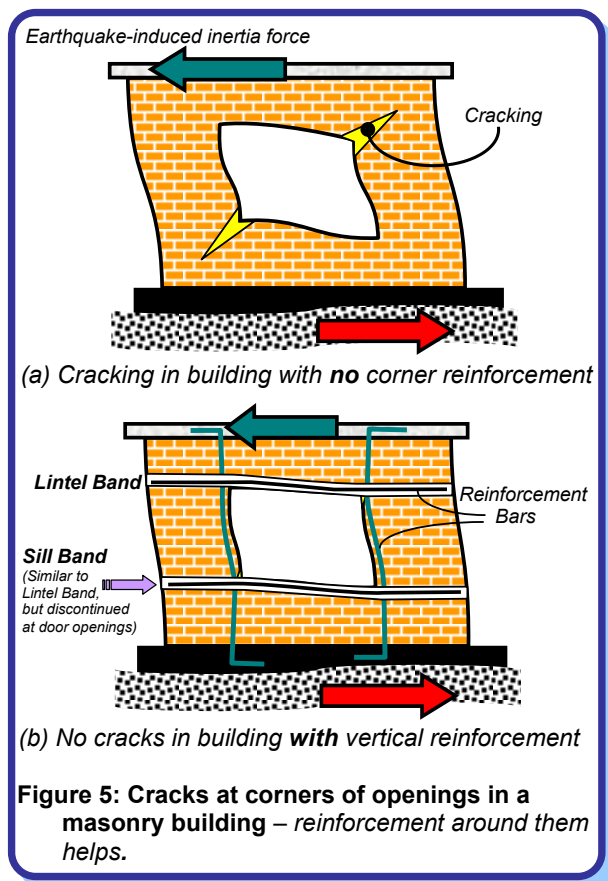

Related IITK - BMTPC Earthquake Tip

- Tip 5: What are the seismic effects on structures?
- Tip12: How brick masonry houses behave during earthquakes?
- Tip13: Why masonry buildings should have simple structural configuration?
- Tip14: Why horizontal bands are required in masonry buildings?

Resource Material

Amrose, J., (1991), *Simplified Design of Masonry Structures*, John Wiley & Sons, Inc., New York, USA.

BMTPC, (2000), *Guidelines: Improving Earthquake Resistance of Housing*, Building Materials and Technology Promotion Council, New Delhi.

IS 4326, (1993), *Indian Standard Code of Practice for Earthquake Resistant Design and Construction of Buildings*, Bureau of Indian Standards, New Delhi.

IS 13828, (1993), *Indian Standard Guidelines for Improving Earthquake Resistance of Low-strength Masonry Buildings*, Bureau of Indian Standards, New Delhi.

Next Upcoming Tip

How to improve seismic behaviour of stone masonry buildings?

Authored by:
 C.V.R.Murty
 Indian Institute of Technology Kanpur
 Kanpur, India
Sponsored by:
 Building Materials and Technology Promotion
 Council, New Delhi, India

This release is a property of IIT Kanpur and BMTPC New Delhi. It may be reproduced without changing its contents and with due acknowledgement. Suggestions/comments may be sent to: egtips@iitk.ac.in. Visit www.nicee.org or www.bmtpc.org, to see previous IITK-BMTPC Earthquake Tips.

How to make Stone Masonry Buildings Earthquake Resistant?

Behaviour during Past India Earthquakes

Stone has been used in building construction in India since ancient times since it is durable and locally available. There are huge numbers of stone buildings in the country, ranging from rural houses to royal palaces and temples. In a typical rural stone house, there are thick stone masonry walls (thickness ranges from 600 to 1200 mm) built using rounded stones from riverbeds bound with mud mortar. These walls are constructed with stones placed in a random manner, and hence do not have the usual layers (or *courses*) seen in brick walls. These uncoursed walls have two exterior vertical layers (called *wythes*) of large stones, filled in between with loose stone rubble and mud mortar. A typical *uncoursed random (UCR)* stone masonry wall is illustrated in Figure 1. In many cases, these walls support heavy roofs (for example, timber roof with thick mud overlay).

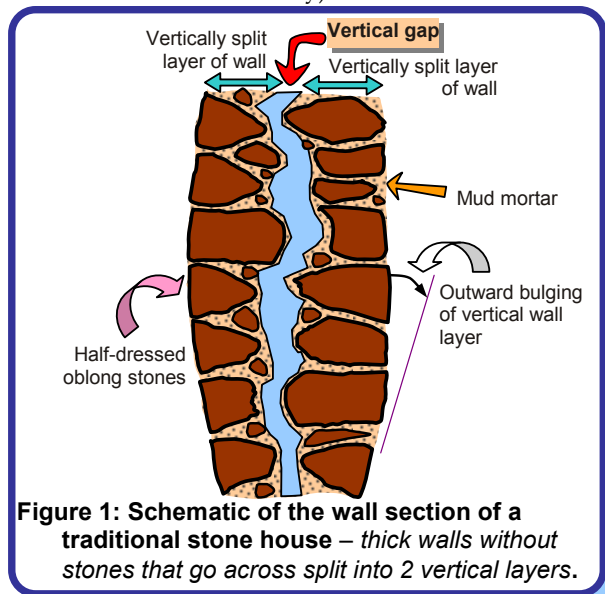

Figure 1: Schematic of the wall section of a traditional stone house – thick walls without stones that go across split into 2 vertical layers.

Laypersons may consider such stone masonry buildings robust due to the large wall thickness and robust appearance of stone construction. But, these buildings are one of the most deficient building systems from earthquake-resistance point of view. The main deficiencies include excessive wall thickness, absence of any connection between the two wythes of the wall, and use of *round* stones (instead of *shaped* ones). Such dwellings have shown very poor performance during past earthquakes in India and other countries (e.g., Greece, Iran, Turkey, former Yugoslavia). In the 1993 Killari (Maharashtra) earthquake alone, over 8,000 people died, most of them buried under the rubble of traditional stone

masonry dwellings. Likewise, a majority of the over 13,800 deaths during 2001 Bhuj (Gujarat) earthquake is attributed to the collapse of this type of construction.

The main patterns of earthquake damage include: (a) bulging/separation of walls in the horizontal direction into two distinct *wythes* (Figure 2a), (b) separation of walls at corners and T-junctions (Figure 2b), (c) separation of poorly constructed roof from walls, and eventual collapse of roof, and (d) disintegration of walls and eventual collapse of the whole dwelling.

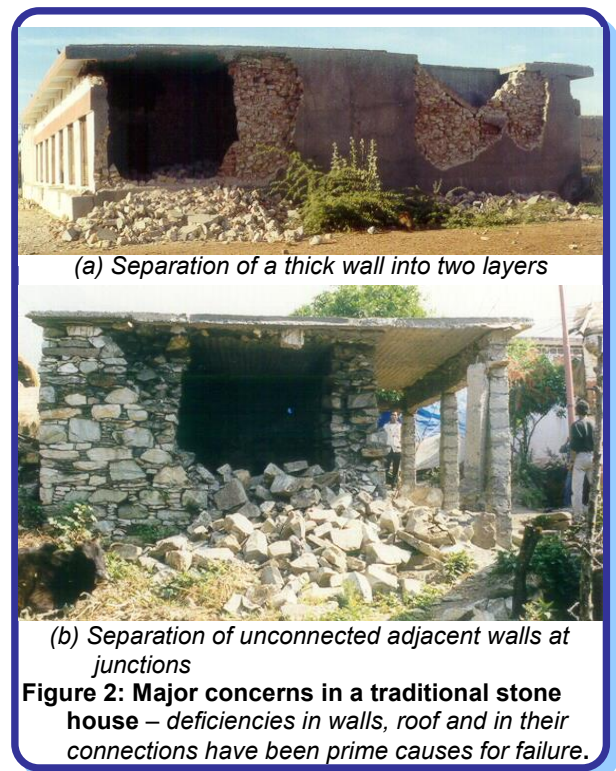

Figure 2: Major concerns in a traditional stone house – deficiencies in walls, roof and in their connections have been prime causes for failure.

Earthquake Resistant Features

Low strength stone masonry buildings are weak against earthquakes, and should be avoided in high seismic zones. The Indian Standard IS:13828-1993 states that inclusion of special earthquake-resistant design and construction features may raise the earthquake resistance of these buildings and reduce the loss of life. However, in spite of the seismic features these buildings may not become totally free from heavy damage and even collapse in case of a major earthquake. The contribution of the each of these features is difficult to quantify, but qualitatively these features have been observed to improve the performance of stone masonry dwellings during past earthquakes. These features include:

How to make Stone Masonry Buildings Earthquake Resistant?

- (a) *Ensure proper wall construction* The wall thickness should not exceed 450mm. Round stone boulders should not be used in the construction! Instead, the stones should be shaped using chisels and hammers. Use of mud mortar should be avoided in higher seismic zones. Instead, cement-sand mortar should be 1:6 (or richer) and lime-sand mortar 1:3 (or richer) should be used.
- (b) *Ensure proper bond in masonry courses:* The masonry walls should be built in construction lifts not exceeding 600mm. Through-stones (each extending over full thickness of wall) or a pair of overlapping bond-stones (each extending over at least 3/4ths thickness of wall) must be used at every 600mm along the height and at a maximum spacing of 1.2m along the length (Figure 3).

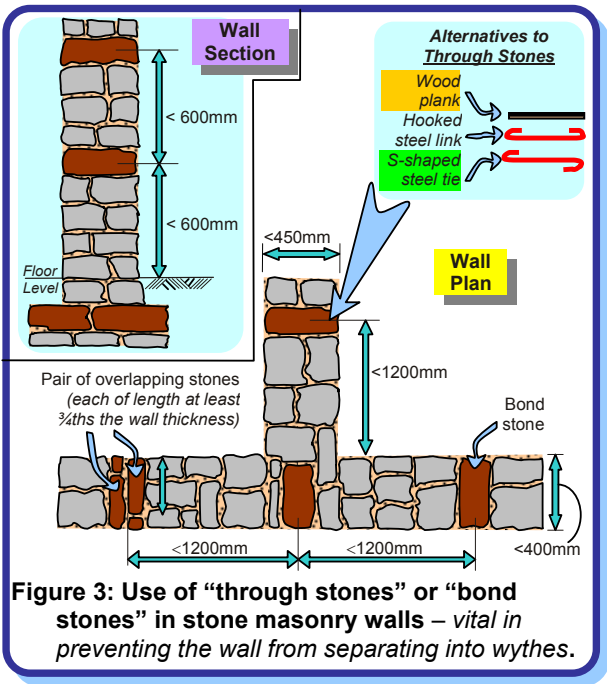

Figure 3: Use of “through stones” or “bond stones” in stone masonry walls – vital in preventing the wall from separating into wythes.

- (c) *Provide horizontal reinforcing elements:* The stone masonry dwellings must have horizontal bands (See IITK-BMTPC Earthquake Tip 14 for plinth, lintel, roof and gable bands). These bands can be constructed out of wood or reinforced concrete, and chosen based on economy. It is important to provide at least one band (either lintel band or roof band) in stone masonry construction (Figure 4).
- (d) *Control on overall dimensions and heights:* The unsupported length of walls between cross-walls should be limited to 5m; for longer walls, cross supports raised from the ground level called buttresses should be provided at spacing not more than 4m. The height of each storey should not exceed 3.0m. In general, stone masonry buildings should not be taller than 2 storeys when built in cement mortar, and 1 storey when built in lime or mud mortar. The wall should have a thickness of at least one-sixth its height.

Although, this type of stone masonry construction practice is deficient with regards to earthquake

resistance, its extensive use is likely to continue due to tradition and low cost. But, to protect human lives and property in future earthquakes, it is necessary to follow proper stone masonry construction as described above (especially features (a) and (b) in seismic zones III and higher). Also, the use of seismic bands is highly recommended (as described in feature (c) above and in IITK-BMTPC Earthquake Tip 14).

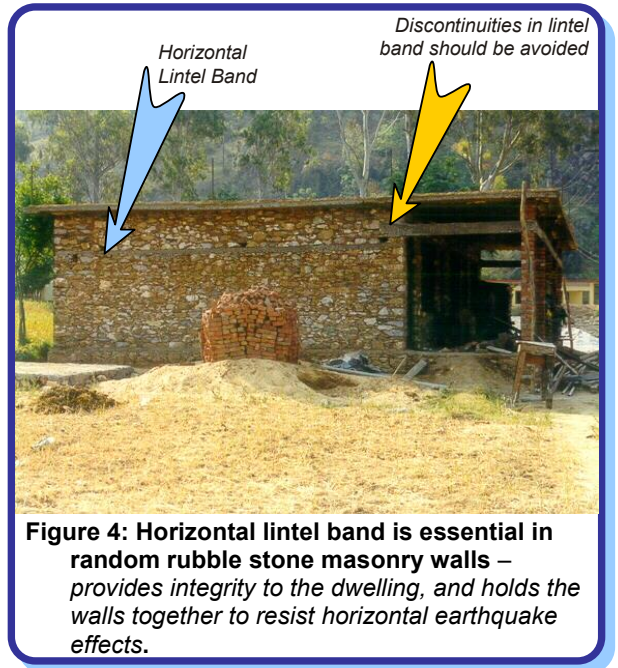

Figure 4: Horizontal lintel band is essential in random rubble stone masonry walls – provides integrity to the dwelling, and holds the walls together to resist horizontal earthquake effects.

Related IITK - BMTPC Earthquake Tip

Tip14: Why horizontal bands are required in masonry buildings?

Resource Material

Brzev,S., Greene,M. and Sinha,R. (2001), “Rubble stone masonry walls with timber walls and timber roof,” *World Housing Encyclopedia* (www.world-housing.net), India/Report 18, published by EERI and IAEE.

IAEE, (1986), *Guidelines for Earthquake Resistant Non-Engineered Construction*, The ACC Limited, Thane, 2001 (See www.niceee.org).

IS 13828, (1993), *Indian Standard Guidelines - Improving Earthquake Resistance of Low-Strength Masonry Buildings*, Bureau of Indian Standards, New Delhi.

Publications of Building Materials and Technology Promotion Council, New Delhi (www.bmtpc.org):

- (a) *Retrofitting of Stone Houses in Marathwada Area of Maharashtra*
- (b) *Guidelines For Improving Earthquake Resistance of Housing*
- (c) *Manual for Repair and Reconstruction of Houses Damaged in Earthquake in October 1991 in the Garhwal Region of UP*

Next Upcoming Tip

What are the seismic effects on RC frame buildings?

Authored by:
 C.V.R.Murty
 Indian Institute of Technology Kanpur
 Kanpur, India
Sponsored by:
 Building Materials and Technology Promotion Council, New Delhi, India

This release is a property of IIT Kanpur and BMTPC New Delhi. It may be reproduced without changing its contents and with due acknowledgement. Suggestions/comments may be sent to: egtips@iitk.ac.in. Visit www.nicee.org or www.bmtpc.org, to see previous IITK-BMTPC Earthquake Tips.

How do Earthquakes Affect Reinforced Concrete Buildings?

Reinforced Concrete Buildings

In recent times, *reinforced concrete* buildings have become common in India, particularly in towns and cities. Reinforced concrete (or simply RC) consists of two primary materials, namely concrete with *reinforcing steel bars*. Concrete is made of *sand, crushed stone (called aggregates)* and *cement*, all mixed with pre-determined amount of water. Concrete can be molded into any desired shape, and steel bars can be bent into many shapes. Thus, structures of complex shapes are possible with RC.

A typical RC building is made of horizontal members (*beams and slabs*) and vertical members (*columns and walls*), and supported by *foundations* that rest on ground. The system comprising of RC columns and connecting beams is called a *RC Frame*. The RC frame participates in resisting the earthquake forces. Earthquake shaking generates inertia forces in the building, which are proportional to the building mass. Since most of the building mass is present at floor levels, earthquake-induced inertia forces primarily develop at the floor levels. These forces travel downwards - through *slab and beams* to *columns and walls*, and then to the foundations from where they are dispersed to the ground. As inertia forces accumulate downwards from the top of the building, the columns and walls at lower storeys experience higher earthquake-induced forces (Figure 1) and are therefore designed to be stronger than those in storeys above.

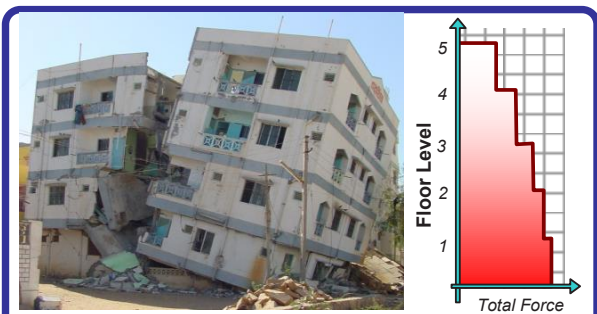

Figure 1: Total horizontal earthquake force in a building increases downwards along its height.

Roles of Floor Slabs and Masonry Walls

Floor slabs are horizontal plate-like elements, which facilitate functional use of buildings. Usually, beams and slabs at one storey level are cast together. In residential multi-storey buildings, thickness of slabs is only about 110-150mm. When beams bend in the vertical direction during earthquakes, these thin slabs bend along with them (Figure 2a). And, when beams move with columns in the horizontal direction, the slab usually forces the beams to move together with it.

In most buildings, the geometric distortion of the slab is negligible in the horizontal plane; this behaviour is known as the *rigid diaphragm action* (Figure 2b). Structural engineers must consider this during design.

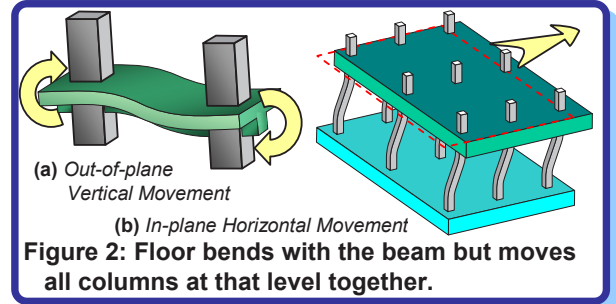

Figure 2: Floor bends with the beam but moves all columns at that level together.

After columns and floors in a RC building are cast and the concrete hardens, vertical spaces between columns and floors are usually filled-in with masonry walls to demarcate a floor area into functional spaces (rooms). Normally, these masonry walls, also called *infill walls*, are not connected to surrounding RC columns and beams. When columns receive horizontal forces at floor levels, they try to move in the horizontal direction, but masonry walls tend to resist this movement. Due to their heavy weight and thickness, these walls attract rather large horizontal forces (Figure 3). However, since masonry is a brittle material, these walls develop cracks once their ability to carry horizontal load is exceeded. Thus, infill walls act like sacrificial fuses in buildings; they develop cracks under severe shaking but help share the load of the beams and columns until cracking. Earthquake performance of infill walls is enhanced by mortars of good strength, making proper masonry courses, and proper packing of gaps between RC frame and masonry infill walls. However, an infill wall that is unduly tall or long in comparison to its thickness can fall *out-of-plane* (i.e., along its thin direction), which can be life threatening. Also, placing infills irregularly in the building causes ill effects like *short-column effect* and *torsion* (these will be discussed in subsequent IITK-BMTPC Earthquake Tips).

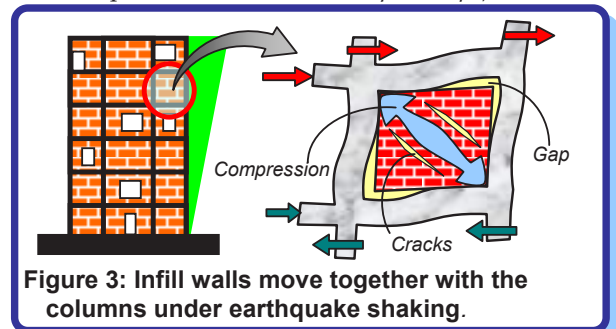

Figure 3: Infill walls move together with the columns under earthquake shaking.

Horizontal Earthquake Effects are Different

Gravity loading (due to self weight and contents) on buildings causes RC frames to bend resulting in stretching and shortening at various locations. Tension is generated at surfaces that stretch and compression at those that shorten (Figure 4b). Under gravity loads, tension in the beams is at the bottom surface of the beam in the central location and is at the top surface at the ends. On the other hand, earthquake loading causes tension on beam and column faces at locations different from those under gravity loading (Figure 4c); the relative levels of this tension (in technical terms, bending moment) generated in members are shown in Figure 4d. The level of bending moment due to earthquake loading depends on severity of shaking and can exceed that due to gravity loading. Thus, under strong earthquake shaking, the beam ends can develop tension on either of the top and bottom faces. Since concrete cannot carry this tension, steel bars are required on both faces of beams to resist reversals of bending moment. Similarly, steel bars are required on all faces of columns too.

Strength Hierarchy

For a building to remain safe during earthquake shaking, columns (which receive forces from beams) should be stronger than beams, and foundations

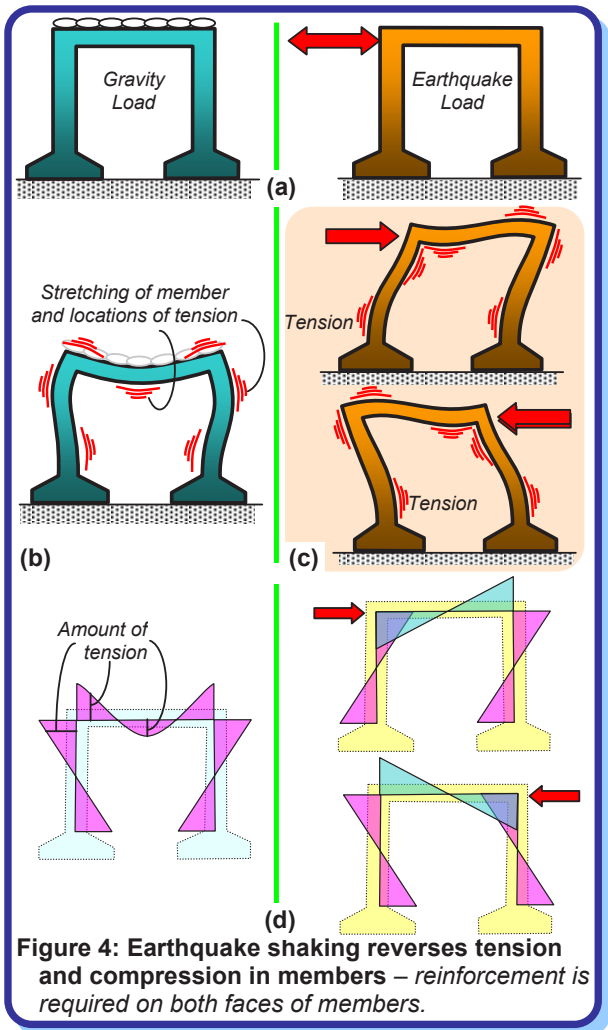

(which receive forces from columns) should be stronger than columns. Further, connections between beams & columns and columns & foundations should not fail so that beams can safely transfer forces to columns and columns to foundations.

When this strategy is adopted in design, damage is likely to occur first in beams (Figure 5a). When beams are detailed properly to have large ductility, the building as a whole can deform by large amounts despite progressive damage caused due to consequent yielding of beams. In contrast, if columns are made weaker, they suffer severe local damage, at the top and bottom of a particular storey (Figure 5b). This localized damage can lead to collapse of a building, although columns at storeys above remain almost undamaged.

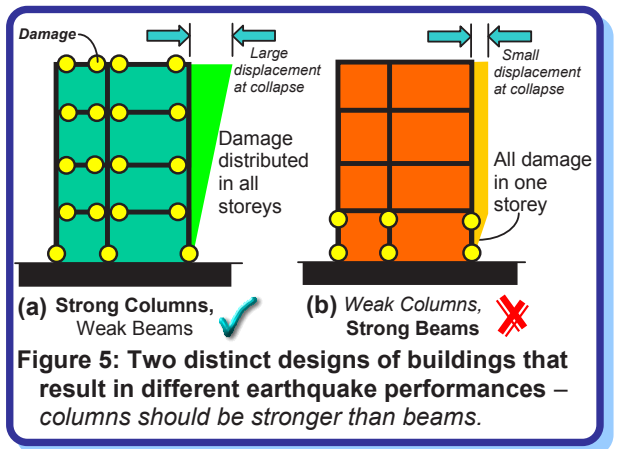

Relevant Indian Standards

The Bureau of Indian Standards, New Delhi, published the following Indian standards pertaining to design of RC frame buildings: (a) Indian Seismic Code (IS 1893 (Part 1), 2002) – for calculating earthquake forces, (b) Indian Concrete Code (IS 456, 2000) – for design of RC members, and (c) Ductile Detailing Code for RC Structures (IS 13920, 1993) – for detailing requirements in seismic regions.

Related IITK - BMTPC Earthquake Tip

Tip 5: What are the seismic effects on structures?

Resource Material

Englekirk, R.E., *Seismic Design of Reinforced and Precast Concrete Buildings*, John Wiley & Sons, Inc., USA, 2003.
 Penelis, G.G., and Kappos, A.J., *Earthquake Resistant Concrete Structures*, E&FN SPON, UK, 1997.

Next Upcoming Tip

How do Beams in RC Buildings Resist Earthquakes?

Authored by:
 C.V.R.Murty
 Indian Institute of Technology Kanpur
 Kanpur, India
 Sponsored by:
 Building Materials and Technology Promotion
 Council, New Delhi, India

This release is a property of IIT Kanpur and BMTPC New Delhi. It may be reproduced without changing its contents and with due acknowledgement. Suggestions/comments may be sent to: egtips@iitk.ac.in. Visit www.nicee.org or www.bmtpc.org, to see previous IITK-BMTPC Earthquake Tips.

How do Beams in RC Buildings Resist Earthquakes?

Reinforcement and Seismic Damage

In RC buildings, the vertical and horizontal members (*i.e.*, the *beams* and *columns*) are built integrally with each other. Thus, under the action of loads, they act together as a *frame* transferring forces from one to another. This Tip is meant for beams that are part of a building frame and carry earthquake-induced forces.

Beams in RC buildings have two sets of steel reinforcement, namely: (a) long straight bars (called *longitudinal bars*) placed along its length, and (b) closed loops of small diameter steel bars (called *stirrups*) placed vertically at regular intervals along its full length (Figure 1).

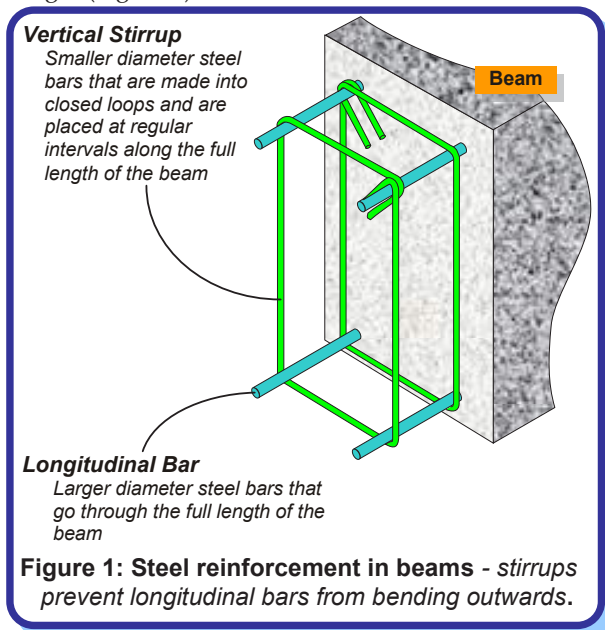

Beams sustain two basic types of failures, namely:

(a) **Flexural (or Bending) Failure:** As the beam sags under increased loading, it can fail in two possible ways. If relatively more steel is present on the tension face, concrete *crushes in compression*; this is a *brittle* failure and is therefore undesirable. If relatively less steel is present on the tension face, the steel yields first (it *keeps elongating* but does not snap, as steel has ability to stretch large amounts before it snaps; see *IITK-BMTPC Earthquake Tip 9*) and redistribution occurs in the beam until eventually the concrete *crushes in compression*; this is a *ductile* failure and hence is desirable. Thus, more steel on tension face is not necessarily desirable! The ductile failure is characterized with many vertical cracks starting from the stretched beam face, and going towards its mid-depth (Figure 2a).

(b) **Shear Failure:** A beam may also fail due to shearing action. A shear crack is inclined at 45° to the horizontal; it develops at mid-depth near the support and grows towards the top and bottom faces (Figure 2b). Closed loop stirrups are provided to avoid such shearing action. Shear damage occurs when the area of these stirrups is *insufficient*. Shear failure is brittle, and therefore, shear failure must be avoided in the design of RC beams.

Design Strategy

Designing a beam involves the selection of *its material properties* (*i.e.*, grades of steel bars and concrete) and *shape and size*; these are usually selected as a part of an overall design strategy of the whole building. And, the *amount and distribution of steel* to be provided in the beam must be determined by performing design calculations as per IS:456-2000 and IS13920-1993.

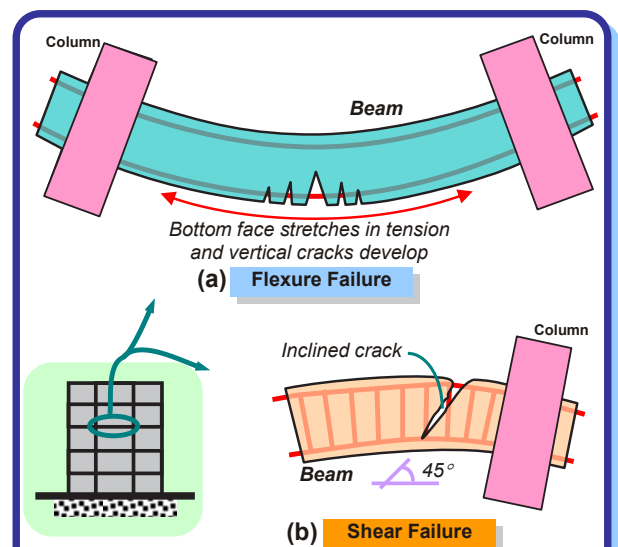

Longitudinal bars are provided to resist flexural cracking on the side of the beam that stretches. Since both top and bottom faces stretch during strong earthquake shaking (*IITK-BMTPC Earthquake Tip 17*), longitudinal steel bars are required on both faces at the ends and on the bottom face at mid-length (Figure 3). The Indian Ductile Detailing Code IS13920-1993 prescribes that:

- At least two bars go through the full length of the beam at the top as well as the bottom of the beam.
- At the ends of beams, the amount of steel provided at the bottom is at least half that at top.

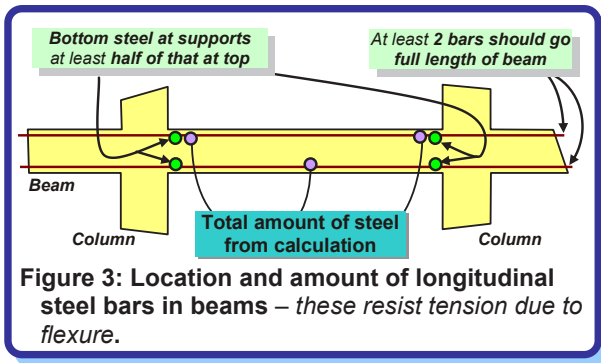

Stirrups in RC beams help in three ways, namely (i) they carry the vertical shear force and thereby resist diagonal shear cracks (Figure 2b), (ii) they protect the concrete from bulging outwards due to flexure, and (iii) they prevent the buckling of the compressed longitudinal bars due to flexure. In moderate to severe seismic zones, the Indian Standard IS13920-1993 prescribes the following requirements related to stirrups in reinforced concrete beams:

- (a) The diameter of stirrup must be at least 6mm; in beams more than 5m long, it must be at least 8mm.
- (b) Both ends of the vertical stirrups should be bent into a 135° hook (Figure 4) and extended sufficiently beyond this hook to ensure that the stirrup does not open out in an earthquake.
- (c) The spacing of vertical stirrups in any portion of the beam should be determined from calculations
- (d) For a length of twice the depth of the beam from the face of the column, an even more stringent spacing of stirrups is specified, namely half the spacing mentioned in (c) above (Figure 5).

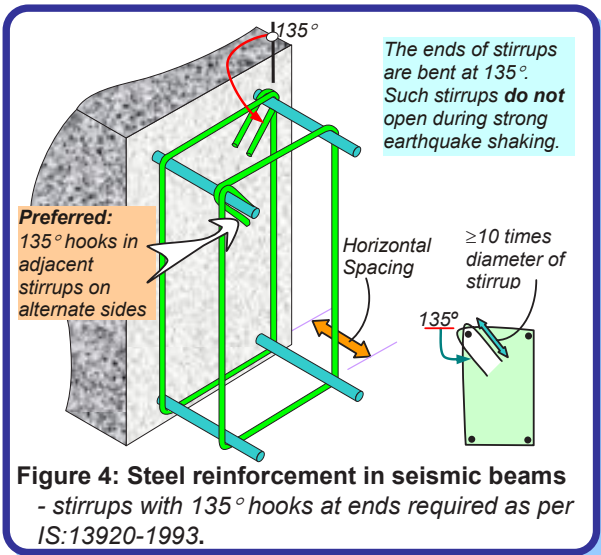

Steel reinforcement bars are available usually in lengths of 12-14m. Thus, it becomes necessary to overlap bars when beams of longer lengths are to be made. At the location of the lap, the bars transfer large forces from one to another. Thus, the Indian Standard IS:13920-1993 prescribes that such laps of longitudinal

bars are (a) made away from the face the column, and (b) not made at locations where they are likely to stretch by large amounts and yield (e.g., bottom bars at mid-length of the beam). Moreover, at the locations of laps, vertical stirrups should be provided at a closer spacing (Figure 6).

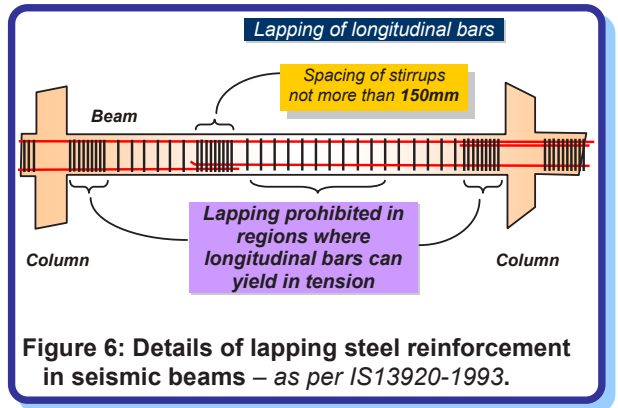
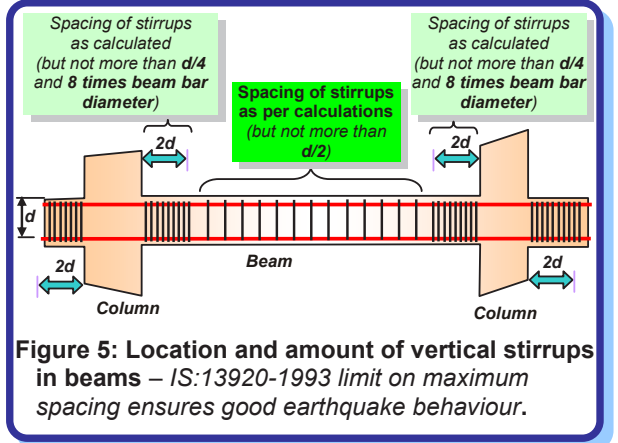

Related IITK - BMTPC Earthquake Tip

Tip 9: How to Make Buildings Ductile for Good Seismic Performance?

Tip 17: How do Earthquakes Affect Reinforced Concrete Buildings?

Resource Material

IS 13920, (1993), Indian Standard Code of Practice for Ductile Detailing of Reinforced Concrete Structures Subjected to Seismic Forces, Bureau of Indian Standards, New Delhi.

Paulay,T., and Priestley,M.J.N., Seismic Design of Masonry and Reinforced Concrete Buildings, John Wiley & Sons, USA, 1992.

McGregor,J.M., Reinforced Concrete Mechanics and Design, Third Edition, Prentice Hall, USA, 1997.

Next Upcoming Tip

How do Columns in RC Buildings Resist Earthquakes?

Authored by:
 C.V.R.Murty
 Indian Institute of Technology Kanpur
 Kanpur, India
Sponsored by:
 Building Materials and Technology Promotion
 Council, New Delhi, India

This release is a property of IIT Kanpur and BMTPC New Delhi. It may be reproduced without changing its contents and with due acknowledgement. Suggestions/comments may be sent to: egtips@iitk.ac.in. Visit www.nicee.org or www.bmtpc.org, to see previous IITK-BMTPC Earthquake Tips.

How do Columns in RC Buildings Resist Earthquakes?

Possible Earthquake Damage

Columns, the vertical members in RC buildings, contain two types of steel reinforcement, namely: (a) long straight bars (called *longitudinal bars*) placed vertically along the length, and (b) closed loops of smaller diameter steel bars (called *transverse ties*) placed horizontally at regular intervals along its full length (Figure 1). Columns can sustain two types of damage, namely *axial-flexural (or combined compression-bending) failure* and *shear failure*. Shear damage is brittle and must be avoided in columns by providing transverse ties at close spacing (Figure 2b).

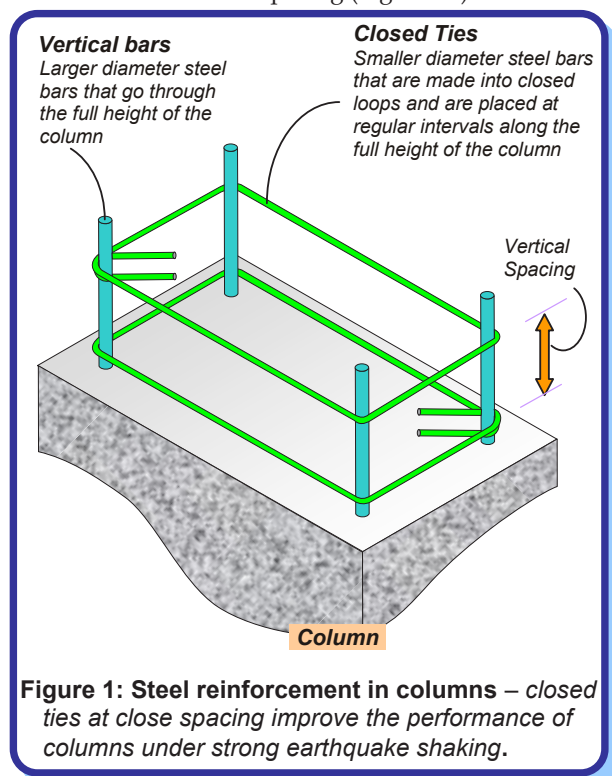

Design Strategy

Designing a column involves selection of *materials to be used (i.e., grades of concrete and steel bars)*, choosing *shape and size of the cross-section*, and calculating *amount and distribution of steel reinforcement*. The first two aspects are part of the overall design strategy of the whole building. The Indian Ductile Detailing Code IS:13920-1993 requires columns to be at least 300mm wide. A column width of up to 200mm is allowed if unsupported length is less than 4m and beam length is less than 5m. Columns that are required to resist earthquake forces must be designed to prevent *shear failure* by a skillful selection of reinforcement.

Vertical Bars tied together with Closed Ties

Closely spaced horizontal closed ties help in three ways, namely (i) they carry the horizontal shear forces induced by earthquakes, and thereby resist diagonal shear cracks, (ii) they hold together the vertical bars and prevent them from excessively bending outwards (in technical terms, this bending phenomenon is called *buckling*), and (iii) they contain the concrete in the column within the closed loops. The ends of the ties must be bent as 135° hooks (Figure 2). Such hook ends prevent opening of loops and consequently buckling of concrete and buckling of vertical bars.

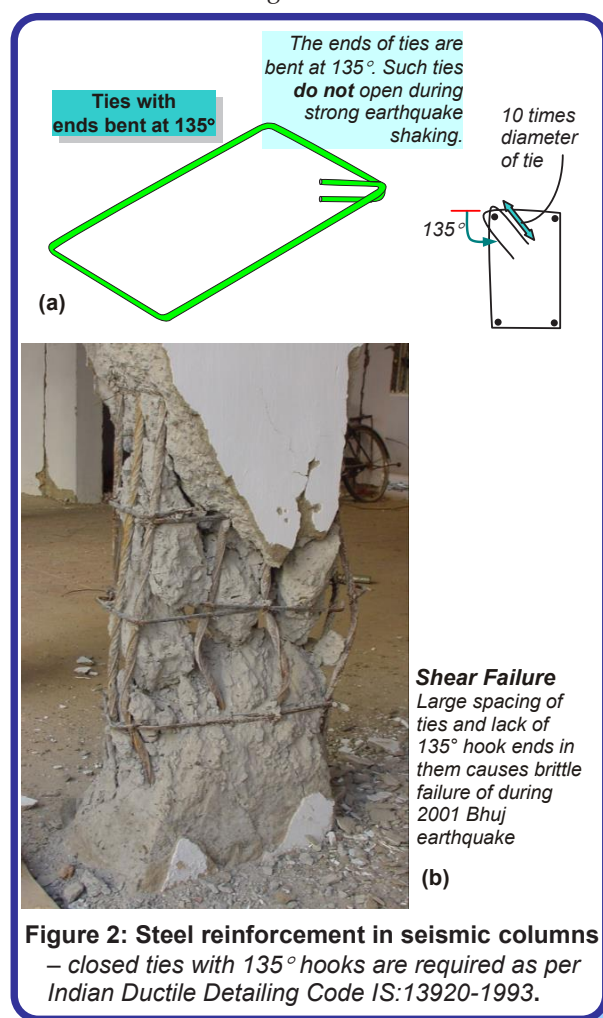

The Indian Standard IS13920-1993 prescribes following details for earthquake-resistant columns:

- (a) Closely spaced ties must be provided at the two ends of the column over a length not less than larger dimension of the column, *one-sixth* the column height or 450mm.

How do Columns in RC Buildings Resist Earthquakes?

- (b) Over the distance specified in item (a) above and below a beam-column junction, the vertical spacing of ties in columns should not exceed $D/4$ for where D is the smallest dimension of the column (e.g., in a rectangular column, D is the length of the small side). This spacing need not be less than 75mm nor more than 100mm. At other locations, ties are spaced as per calculations but not more than $D/2$.
- (c) The length of tie beyond the 135° bends must be at least 10 times diameter of steel bar used to make the closed tie; this extension beyond the bend should not be less than 75mm.

Construction drawings with clear details of closed ties are helpful in the effective implementation at construction site. In columns where the spacing between the corner bars exceeds 300mm, the Indian Standard prescribes additional links with 180° hook ends for ties to be effective in holding the concrete in its place and to prevent the buckling of vertical bars. These links need to go around both vertical bars and horizontal closed ties (Figure 3); special care is required to implement this properly at site.

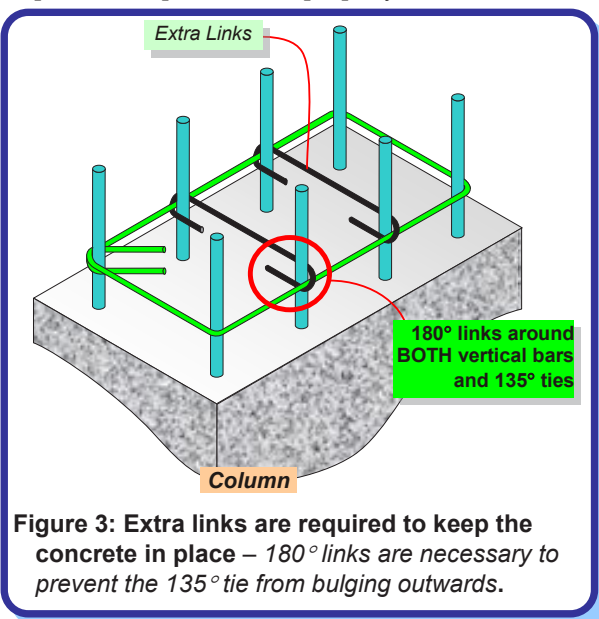

Figure 3: Extra links are required to keep the concrete in place – 180° links are necessary to prevent the 135° tie from bulging outwards.

Lapping Vertical Bars

In the construction of RC buildings, due to the limitations in available length of bars and due to constraints in construction, there are numerous occasions when column bars have to be joined. A simple way of achieving this is by overlapping the two bars over at least a minimum specified length, called lap length. The lap length depends on types of reinforcement and concrete. For ordinary situations, it is about 50 times bar diameter. Further, IS:13920-1993 prescribes that the lap length be provided ONLY in the middle half of column and not near its top or bottom ends (Figure 4). Also, only half the vertical bars in the column are to be lapped at a time in any storey. Further, when laps are provided, ties must be provided along the length of the lap at a spacing not more than 150mm.

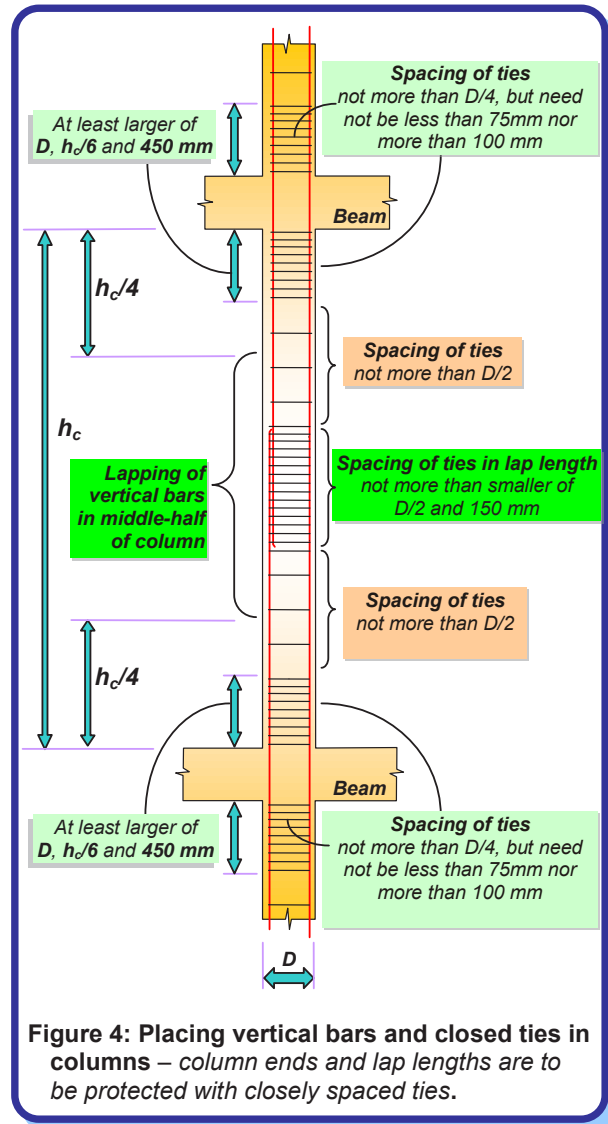

Figure 4: Placing vertical bars and closed ties in columns – column ends and lap lengths are to be protected with closely spaced ties.

Related IITK - BMTPC Earthquake Tip

- Tip17: How do Earthquakes Affect Reinforced Concrete Buildings?
- Tip18: How do Beams in RC Buildings Resist Earthquakes?

Resource Material

IS 13920, (1993), Indian Standard Code of Practice for Ductile Detailing of Reinforced Concrete Structures Subjected to Seismic Forces, Bureau of Indian Standards, New Delhi.
 Paulay, T., and Priestley, M.J.N., Seismic Design of Masonry and Reinforced Concrete Buildings, John Wiley & Sons, USA, 1992.

Next Upcoming Tip

How do Beam-Column Joints in RC Buildings Resist Earthquakes?

Authored by:
 C.V.R.Murty
 Indian Institute of Technology Kanpur
 Kanpur, India
 Sponsored by:
 Building Materials and Technology Promotion
 Council, New Delhi, India

This release is a property of IIT Kanpur and BMTPC New Delhi. It may be reproduced without changing its contents and with due acknowledgement. Suggestions/comments may be sent to: egtips@iitk.ac.in. Visit www.nicee.org or www.bmtpc.org, to see previous IITK-BMTPC Earthquake Tips.

How do Beam-Column Joints in RC Buildings Resist Earthquakes?

Why Beam-Column Joints are Special

In RC buildings, portions of *columns* that are common to *beams* at their intersections are called *beam-column joints* (Figure 1). Since their constituent materials have limited strengths, the joints have *limited force carrying capacity*. When forces larger than these are applied during earthquakes, joints are severely damaged. Repairing damaged joints is difficult, and so damage must be avoided. Thus, beam-column joints must be designed to resist earthquake effects.

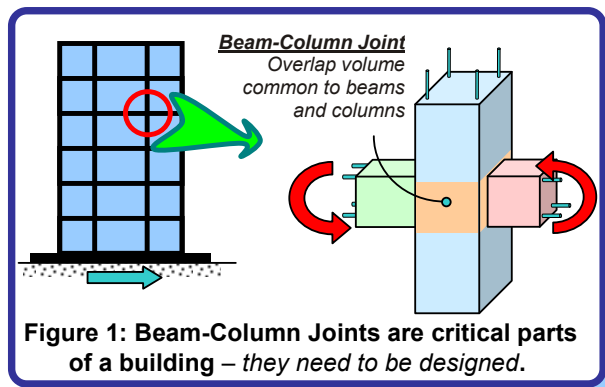

Earthquake Behaviour of Joints

Under earthquake shaking, the beams adjoining a joint are subjected to moments in the same (clockwise or counter-clockwise) direction (Figure 1). Under these moments, the top bars in the beam-column joint are pulled in one direction and the bottom ones in the opposite direction (Figure 2a). These forces are balanced by bond stress developed between concrete and steel in the joint region. If the column is not wide enough or if the strength of concrete in the joint is low, there is insufficient grip of concrete on the steel bars. In such circumstances, the bar slips inside the joint region, and beams lose their capacity to carry load.

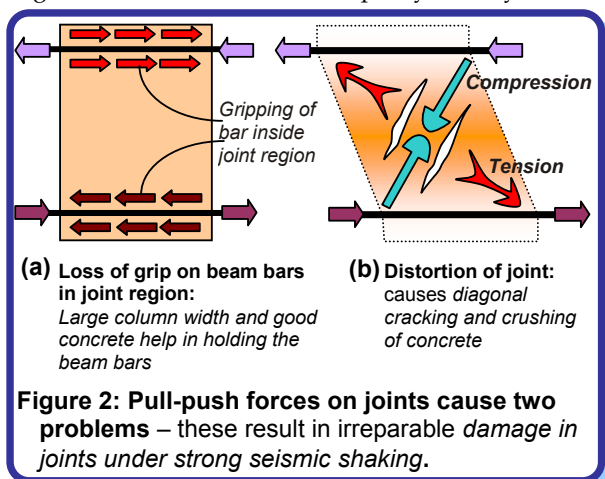

Further, under the action of the above pull-push forces at top and bottom ends, joints undergo geometric distortion; one diagonal length of the joint elongates and the other compresses (Figure 2b). If the column cross-sectional size is insufficient, the concrete in the joint develops diagonal cracks.

Reinforcing the Beam-Column Joint

Problems of diagonal cracking and crushing of concrete in the joint region can be controlled by two means, namely *providing large column sizes* and *providing closely spaced closed-loop steel ties* around column bars in the joint region (Figure 3). The ties hold together the concrete in the joint and also resist shear force, thereby reducing the cracking and crushing of concrete.

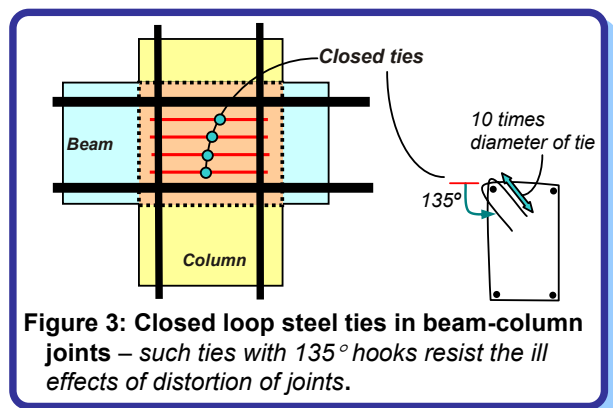

Providing closed-loop ties in the joint requires some extra effort. Indian Standard IS:13920-1993 recommends continuing the transverse loops around the column bars through the joint region. In practice, this is achieved by preparing the cage of the reinforcement (both *longitudinal bars* and *stirrups*) of all beams at a floor level to be prepared on top of the beam formwork of that level and lowered into the cage (Figures 4a and 4b). However, this may not always be possible particularly when the beams are long and the entire reinforcement cage becomes heavy.

Anchoring Beam Bars

The gripping of beam bars in the joint region is improved *first* by using columns of reasonably large cross-sectional size. As explained in *Earthquake Tip 19*, the Indian Standard IS:13920-1993 requires building columns in seismic zones III, IV and V to be at least 300mm wide in each direction of the cross-section when they support beams that are longer than 5m or when these columns are taller than 4m between floors (or beams). The American Concrete Institute recommends a column width of at least 20 times the diameter of largest longitudinal bar used in adjoining beam.

How do Beam-Column Joints in RC Buildings Resist Earthquakes?

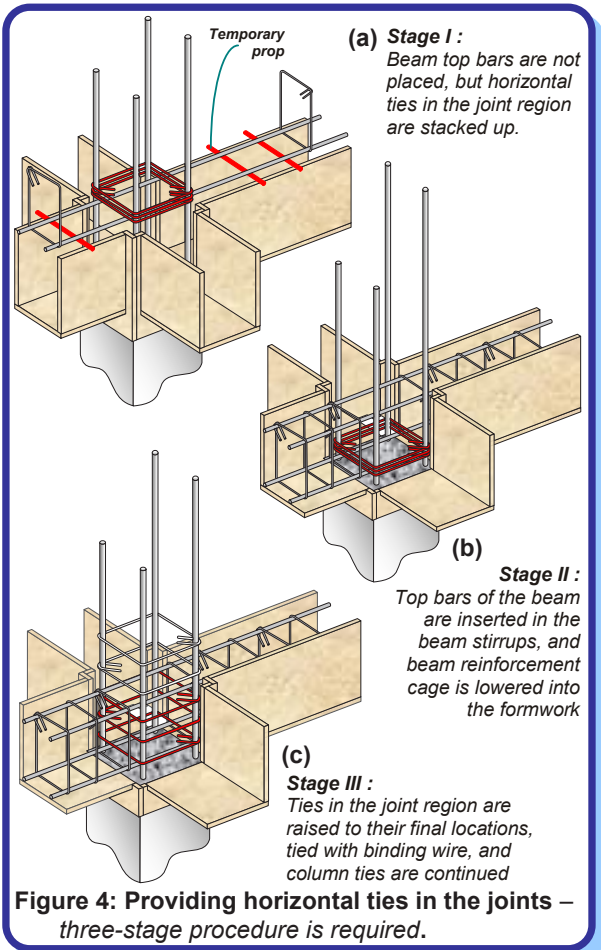

In exterior joints where beams terminate at columns (Figure 5), longitudinal beam bars need to be anchored into the column to ensure proper gripping of bar in joint. The length of anchorage for a bar of grade Fe415 (characteristic tensile strength of 415MPa) is about 50 times its diameter. This length is measured from the face of the column to the end of the bar anchored in the column. In columns of small widths and when beam bars are of large diameter (Figure 5a), a portion of beam top bar is embedded in the column that is cast up to the soffit of the beam, and a part of it overhangs. It is difficult to hold such an overhanging

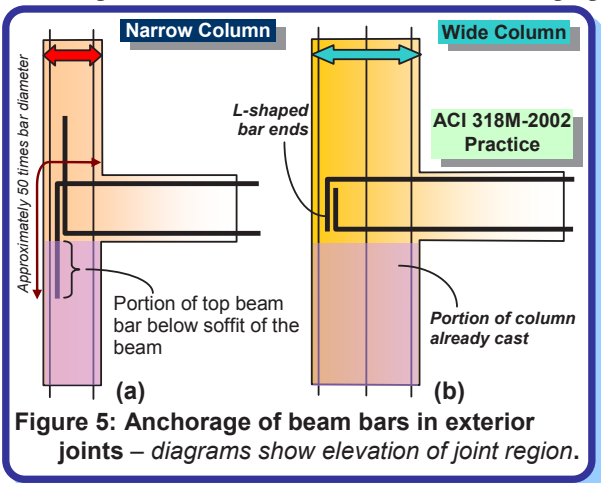

beam top bar in position while casting the column up to the soffit of the beam. On the other hand, if column width is large, the beam bars may not extend below the soffit of the beam (Figure 5b). Thus, it is preferable to have columns with sufficient width. Such an approach has been used in the American practice [ACI318M, 2002].

In interior joints, the beam bars (both top and bottom) need to go through the joint without any cut in the joint region. Also, these bars must be placed within the column bars and with no bends (Figure 6).

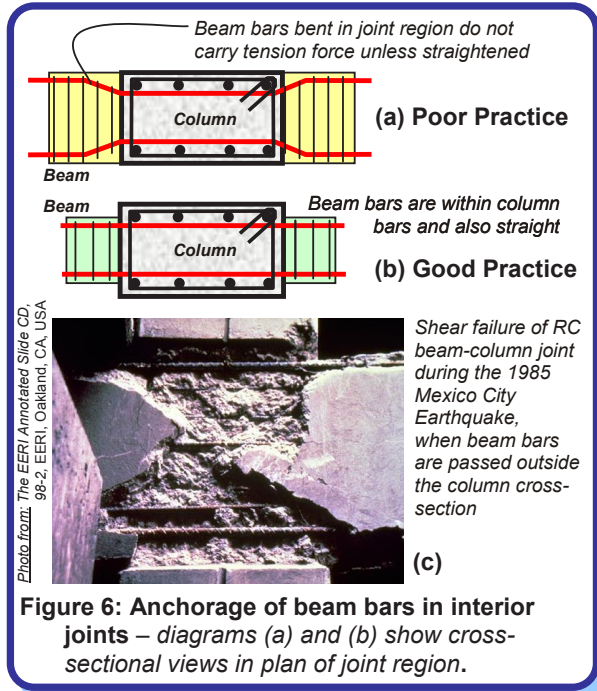

Related IITK - BMTPC Earthquake Tip

- Tip17: How do Earthquakes Affect Reinforced Concrete Buildings?
- Tip18: How do Beams in RC Buildings Resist Earthquakes?
- Tip19: How do Columns in RC Buildings Resist Earthquakes?

Resource Material

- ACI 318M, (2002), *Building Code Requirements for Structural Concrete and Commentary*, American Concrete Institute, Farmington Hills, (MI), USA.
- IS 13920, (1993), *Indian Standard Code of Practice for Ductile Detailing of Reinforced Concrete Structures Subjected to Seismic Forces*, Bureau of Indian Standards, New Delhi.
- SP 123, *Design of Beam-Column Joints for Seismic Resistance*, Special Publication, American Concrete Institute, USA, 1991

Next Upcoming Tip

Why are Open-Ground Storey Buildings Dangerous in Earthquakes?

Authored by:
C.V.R.Murthy
Indian Institute of Technology Kanpur
Kanpur, India
Sponsored by:
Building Materials and Technology Promotion
Council, New Delhi, India

This release is a property of IIT Kanpur and BMTPC New Delhi. It may be reproduced without changing its contents and with due acknowledgement. Suggestions/comments may be sent to: egtips@iitk.ac.in. Visit www.nicce.org or www.bmtpc.org, to see previous IITK-BMTPC Earthquake Tips.

November 2003

Why are Open-Ground Storey Buildings Vulnerable in Earthquakes?

Basic Features

Reinforced concrete (RC) frame buildings are becoming increasingly common in urban India. Many such buildings constructed in recent times have a special feature – the ground storey is left *open* for the purpose of parking (Figure 1), *i.e.*, columns in the ground storey do not have any partition walls (of either masonry or RC) between them. Such buildings are often called *open ground storey buildings* or *buildings on stilts*.



Figure 1: Ground storeys of reinforced concrete buildings are left open to facilitate parking – this is common in urban areas in India.

An open ground storey building, having *only columns* in the ground storey and *both partition walls and columns* in the upper storeys, have two distinct characteristics, namely:

- It is relatively *flexible* in the ground storey, *i.e.*, the relative horizontal displacement it undergoes in the ground storey is much larger than what each of the storeys above it does. This flexible ground storey is also called *soft storey*.
- It is relatively *weak* in ground storey, *i.e.*, the total horizontal earthquake force it can carry in the ground storey is significantly smaller than what each of the storeys above it can carry. Thus, the open ground storey may also be a *weak storey*.

Often, open ground storey buildings are called *soft storey buildings*, even though their ground storey may be *soft and weak*. Generally, the soft or weak storey usually exists at the ground storey level, but it could be at any other storey level too.

Earthquake Behaviour

Open ground storey buildings have consistently shown poor performance during past earthquakes across the world (for example during 1999 *Turkey*, 1999 *Taiwan* and 2003 *Algeria* earthquakes); a significant number of them have collapsed. A large number of buildings with open ground storey have been built in India in recent years. For instance, the city of

Ahmedabad alone has about 25,000 *five-storey* buildings and about 1,500 *eleven-storey* buildings; majority of them have open ground storeys. Further, a huge number of similarly designed and constructed buildings exist in the various towns and cities situated in moderate to severe seismic zones (namely III, IV and V) of the country. The collapse of more than a hundred RC frame buildings with open ground storeys at Ahmedabad (~225km away from epicenter) during the 2001 Bhuj earthquake has emphasised that such buildings are *extremely* vulnerable under earthquake shaking.

The presence of walls in upper storeys makes them much stiffer than the open ground storey. Thus, the upper storeys move almost together as a single block, and most of the horizontal displacement of the building occurs in the soft ground storey itself. In common language, this type of buildings can be explained as a building on chopsticks. Thus, such buildings swing *back-and-forth* like *inverted pendulums* during earthquake shaking (Figure 2a), and the columns in the open ground storey are severely stressed (Figure 2b). If the columns are weak (do not have the required strength to resist these high stresses) or if they do not have adequate ductility (See *IIT-BMTPC Earthquake Tip 9*), they may be severely damaged (Figure 3a) which may even lead to collapse of the building (Figure 3b).

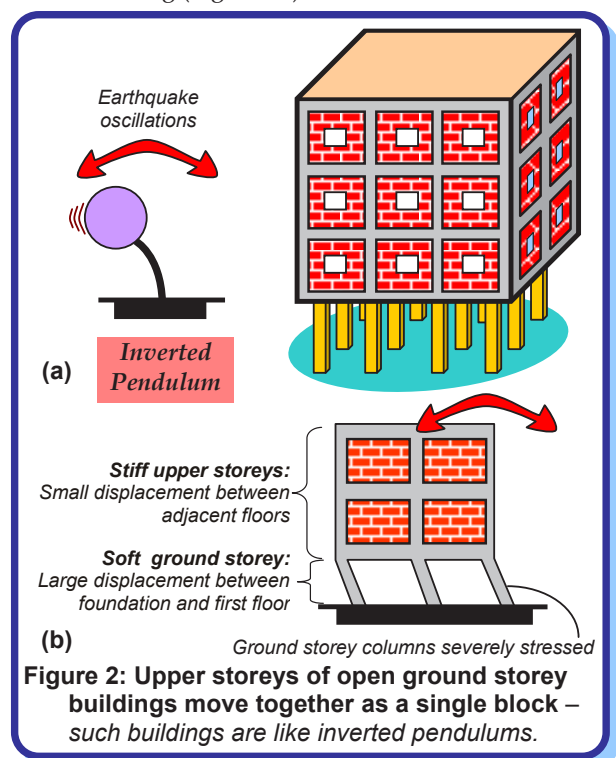

Figure 2: Upper storeys of open ground storey buildings move together as a single block – such buildings are like inverted pendulums.

Why are Open-Ground Storey Buildings Vulnerable in Earthquakes?



Photo Courtesy: The EERI Annotated Slide Set CD, Earthquake Engineering Research Institute, Oakland (CA), USA, 1998.

(a) 1971 San Fernando Earthquake



(b) 2001 Bhuj Earthquake

Figure 3: Consequences of open ground storeys in RC frame buildings – severe damage to ground storey columns and building collapses.

The Problem

Open ground storey buildings are *inherently poor* systems with sudden drop in stiffness and strength in the ground storey. In the current practice, *stiff* masonry walls (Figure 4a) are neglected and only *bare frames* are considered in design calculations (Figure 4b). Thus, the inverted pendulum effect is not captured in design.

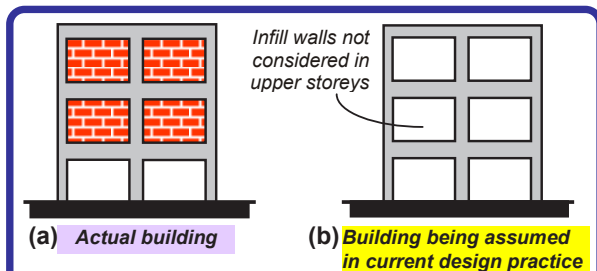

Figure 4: Open ground storey building – assumptions made in current design practice are not consistent with the actual structure.

Improved design strategies

After the collapses of RC buildings in 2001 Bhuj earthquake, the Indian Seismic Code IS:1893 (Part 1) - 2002 has included special design provisions related to soft storey buildings. Firstly, it specifies when a building should be considered as a *soft* and a *weak* storey building. Secondly, it specifies higher design forces for the soft storey as compared to the rest of the

structure. The Code suggests that the forces in the columns, beams and shear walls (if any) under the action of seismic loads specified in the code, may be obtained by considering the *bare frame* building (without any infills) (Figure 4b). However, beams and columns in the *open ground storey* are required to be designed for 2.5 times the forces obtained from this bare frame analysis.

For all *new RC frame buildings*, the best option is to avoid such sudden and large decrease in stiffness and/or strength in any storey; it would be ideal to build walls (either masonry or RC walls) in the ground storey also (Figure 5). Designers can avoid dangerous effects of flexible and weak ground storeys by ensuring that too many walls are not discontinued in the ground storey, *i.e.*, the drop in stiffness and strength in the ground storey level is not abrupt due to the absence of infill walls.

The *existing open ground storey buildings* need to be strengthened suitably so as to prevent them from collapsing during strong earthquake shaking. The owners should seek the services of qualified structural engineers who are able to suggest appropriate solutions to increase seismic safety of these buildings.

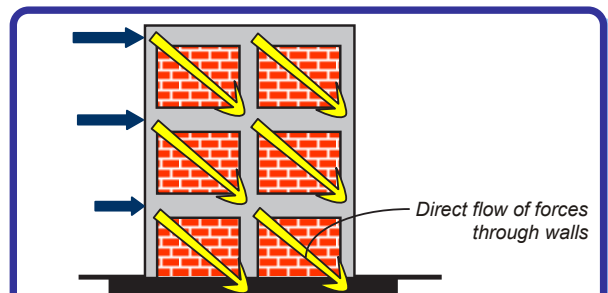

Figure 5: Avoiding open ground storey problem – continuity of walls in ground storey is preferred.

Related IITK - BMTPC Earthquake Tip

Tip 6: How Architectural Features Affect Buildings During Earthquakes?

Tip17: What are the Earthquake Effects on Reinforced Concrete Buildings?

Resource Material

IS 1893(Part 1) (2002), Indian Standard Code of Practice for Criteria for Design of Earthquake Resistant Structures, Bureau of Indian Standards, New Delhi.

Next Upcoming Tip

Why are short columns more damaged during earthquakes?

Authored by:

C.V.R.Murty
Indian Institute of Technology Kanpur
Kanpur, India

Sponsored by:

Building Materials and Technology Promotion
Council, New Delhi, India

This release is a property of IIT Kanpur and BMTPC New Delhi. It may be reproduced without changing its contents and with due acknowledgement. Suggestions/comments may be sent to: eqtips@iitk.ac.in. Visit www.nicee.org or www.bmtpc.org, to see previous IITK-BMTPC Earthquake Tips.

Why are Short Columns more Damaged During Earthquakes?

Which Columns are short?

During past earthquakes, reinforced concrete (RC) frame buildings that have columns of different heights within one storey, suffered more damage in the shorter columns as compared to taller columns in the same storey. Two examples of buildings with short columns are shown in Figure 1 – buildings on a sloping ground and buildings with a mezzanine floor.

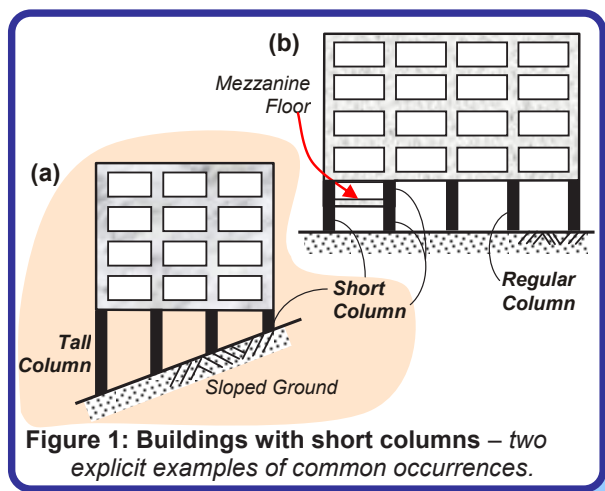

Poor behaviour of short columns is due to the fact that in an earthquake, a tall column and a short column of same cross-section move horizontally by same amount Δ (Figure 2). However, the short column is stiffer as compared to the tall column, and it attracts larger earthquake force. Stiffness of a column means resistance to deformation – the larger is the stiffness, larger is the force required to deform it. If a short column is not adequately designed for such a large force, it can suffer significant damage during an earthquake. This behaviour is called *Short Column Effect*. The damage in these short columns is often in the form of X-shaped cracking – this type of damage of columns is due to *shear failure* (see IITK-BMTPC Earthquake Tip 19).

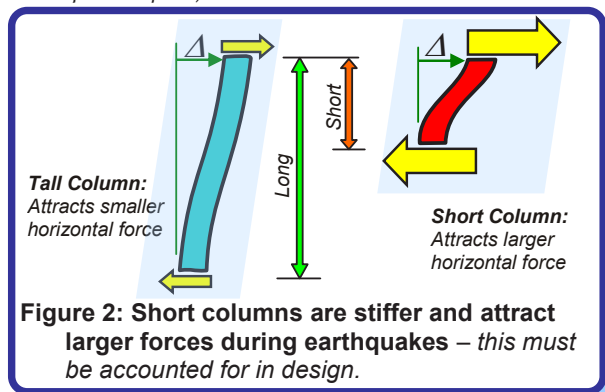

The Short Column Behaviour

Many situations with short column effect arise in buildings. When a building is rested on sloped ground (Figure 1a), during earthquake shaking all columns move horizontally by the same amount along with the floor slab at a particular level (this is called *rigid floor diaphragm action*; see IITK-BMTPC Earthquake Tip 17). If short and tall columns exist within the same storey level, then the short columns attract several times larger earthquake force and suffer more damage as compared to taller ones.

The short column effect also occurs in columns that support mezzanine floors or loft slabs that are added in between two regular floors (Figures 1b).

There is another special situation in buildings when short-column effect occurs. Consider a wall (masonry or RC) of partial height built to fit a window over the remaining height. The adjacent columns behave as short columns due to presence of these walls. In many cases, other columns in the same storey are of regular height, as there are no walls adjoining them. When the floor slab moves horizontally during an earthquake, the upper ends of these columns undergo the same displacement (Figure 3). However, the stiff walls restrict horizontal movement of the lower portion of a short column, and it deforms by the full amount over the *short height* adjacent to the window opening. On the other hand, regular columns deform over the *full height*. Since the effective height over which a short column can freely bend is small, it offers more resistance to horizontal motion and thereby attracts a larger force as compared to the regular column. As a result, short column sustains more damage. Figure 4 shows X-cracking in a column adjacent to the walls of partial height.

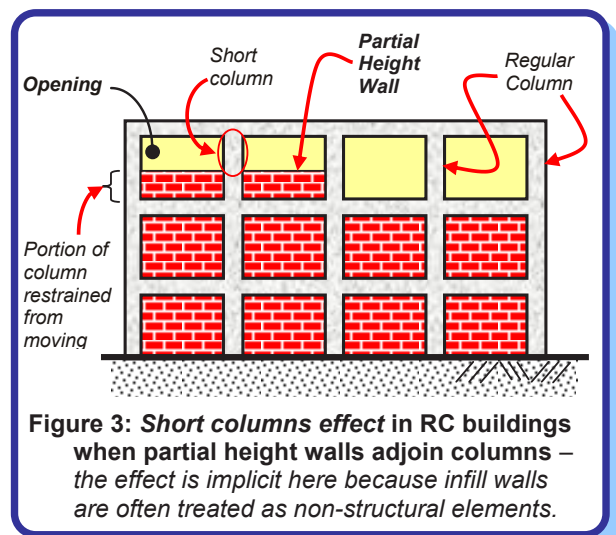

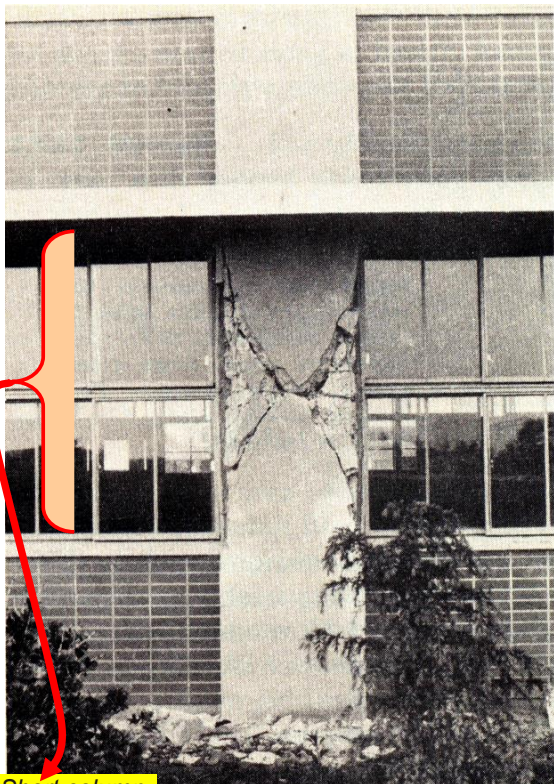

Short column between lintel and sill of window

Source: Wakabayashi, M., *Design of Earthquake-Resistant Buildings*, McGraw Hill Book Company, New York,

Figure 4: Effective height of column over which it can bend is restricted by adjacent walls – this short-column effect is most severe when opening height is small.

The Solution

In new buildings, *short column effect* should be avoided to the extent possible during *architectural design* stage itself. When it is not possible to avoid short columns, this effect must be addressed in structural design. The Indian Standard IS:13920-1993 for ductile detailing of RC structures requires special confining reinforcement to be provided over the *full height* of columns that are likely to sustain short column effect. The special confining reinforcement (i.e., closely spaced closed ties) must extend beyond the short column into the columns vertically above and below by a certain distance as shown in Figure 5. See *IITK-BMTPC Earthquake Tip 19* for details of the special confinement reinforcement.

In existing buildings with short columns, different retrofit solutions can be employed to avoid damage in future earthquakes. Where walls of partial height are present, the simplest solution is to close the openings by building a wall of full height – this will eliminate the short column effect. If that is not possible, short columns need to be strengthened using one of the well established retrofit techniques. The retrofit solution should be designed by a qualified structural engineer with requisite background.

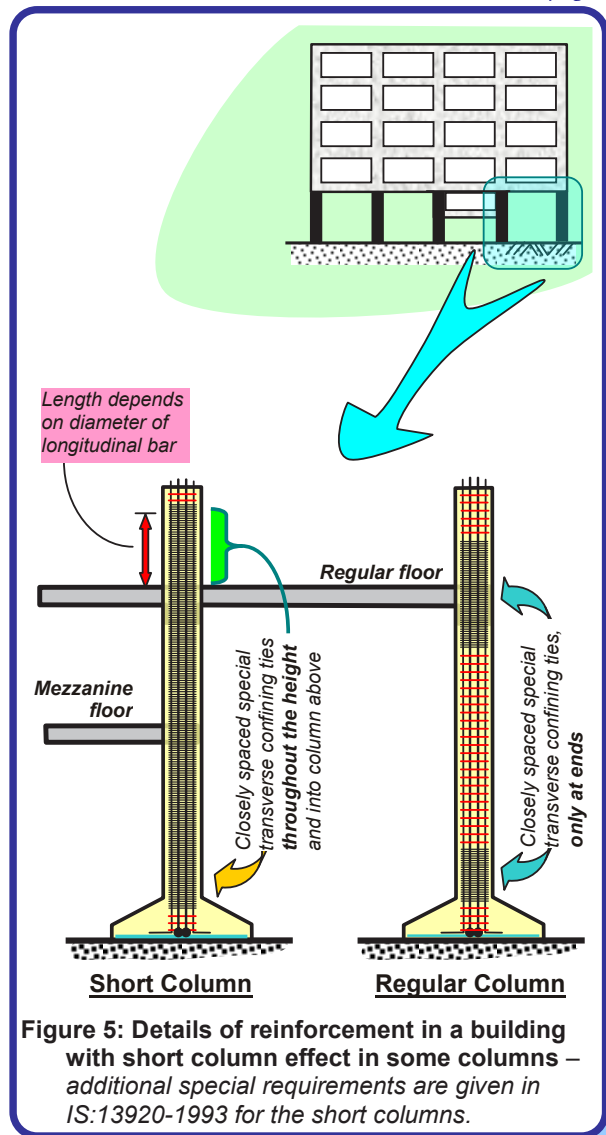

Figure 5: Details of reinforcement in a building with short column effect in some columns – additional special requirements are given in IS:13920-1993 for the short columns.

Related IITK - BMTPC Earthquake Tip

- Tip 6: How Architectural Features Affect Buildings During Earthquakes?
- Tip 17: How do Earthquakes Affect Reinforced Concrete Buildings?
- Tip 19: How do Columns in RC Buildings Resist Earthquakes?

Resource Material

IS 13920, (1993), *Indian Standard Code of Practice for Ductile Detailing of Reinforced Concrete Structures Subjected to Seismic Forces*, Bureau of Indian Standards, New Delhi.

Next Upcoming Tip

Why are buildings with shear walls preferred in seismic regions?

Authored by:
 C.V.R.Murty
 Indian Institute of Technology Kanpur
 Kanpur, India
 Sponsored by:
 Building Materials and Technology Promotion
 Council, New Delhi, India

This release is a property of IIT Kanpur and BMTPC New Delhi. It may be reproduced without changing its contents and with due acknowledgement. Suggestions/comments may be sent to: egtips@iitk.ac.in. Visit www.nicce.org or www.bmtpc.org, to see previous IITK-BMTPC Earthquake Tips.
 January 2004

Why are Buildings with Shear Walls Preferred in Seismic Regions?

What is a Shear Wall Building

Reinforced concrete (RC) buildings often have *vertical plate-like* RC walls called *Shear Walls* (Figure 1) in addition to slabs, beams and columns. These walls generally start at foundation level and are continuous throughout the building height. Their thickness can be as low as 150mm, or as high as 400mm in high rise buildings. Shear walls are usually provided along *both* length and width of buildings (Figure 1). Shear walls are like *vertically-oriented wide beams* that carry earthquake loads downwards to the foundation.

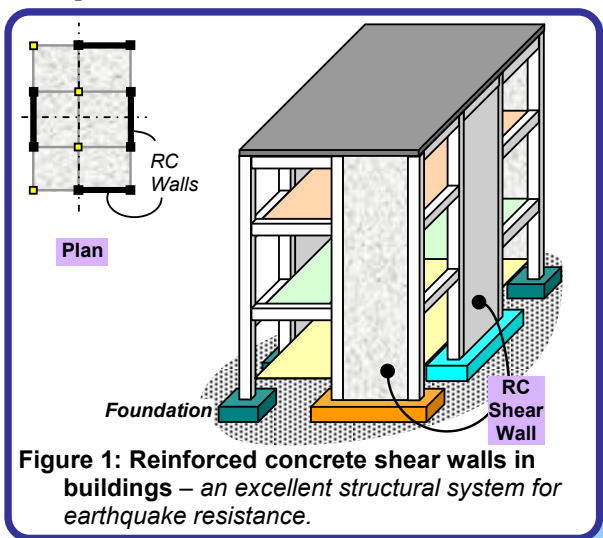

Figure 1: Reinforced concrete shear walls in buildings – an excellent structural system for earthquake resistance.

Advantages of Shear Walls in RC Buildings

Properly designed and detailed buildings with shear walls have shown *very good* performance in past earthquakes. The overwhelming success of buildings with shear walls in resisting strong earthquakes is summarised in the quote:

"We cannot afford to build concrete buildings meant to resist severe earthquakes without shear walls."

:: Mark Fintel, a noted consulting engineer in USA

Shear walls in high seismic regions require special detailing. However, in past earthquakes, even buildings with sufficient amount of walls that were not specially detailed for seismic performance (but had enough well-distributed reinforcement) were saved from collapse. Shear wall buildings are a popular choice in many earthquake prone countries, like Chile, New Zealand and USA. Shear walls are easy to construct, because reinforcement detailing of walls is relatively straight-forward and therefore easily implemented at site. Shear walls are efficient, both in terms of construction cost and effectiveness in minimizing earthquake damage in structural and non-

structural elements (like glass windows and building contents).

Architectural Aspects of Shear Walls

Most RC buildings with shear walls also have columns; these columns primarily carry *gravity* loads (*i.e.*, those due to self-weight and contents of building). Shear walls provide large strength and stiffness to buildings in the direction of their orientation, which significantly reduces lateral sway of the building and thereby reduces damage to structure and its contents. Since shear walls carry *large* horizontal earthquake forces, the overturning effects on them are large. Thus, design of their foundations requires special attention. Shear walls should be provided along preferably *both* length and width. However, if they are provided along only one direction, a proper grid of beams and columns in the vertical plane (called a *moment-resistant frame*) must be provided along the other direction to resist strong earthquake effects.

Door or window openings can be provided in shear walls, but their size must be small to ensure least interruption to force flow through walls. Moreover, openings should be symmetrically located. Special design checks are required to ensure that the net cross-sectional area of a wall at an opening is sufficient to carry the horizontal earthquake force.

Shear walls in buildings must be symmetrically located in plan to reduce ill-effects of twist in buildings (Figure 2). They could be placed symmetrically along one or both directions in plan. Shear walls are more effective when located along exterior perimeter of the building – such a layout increases resistance of the building to twisting.

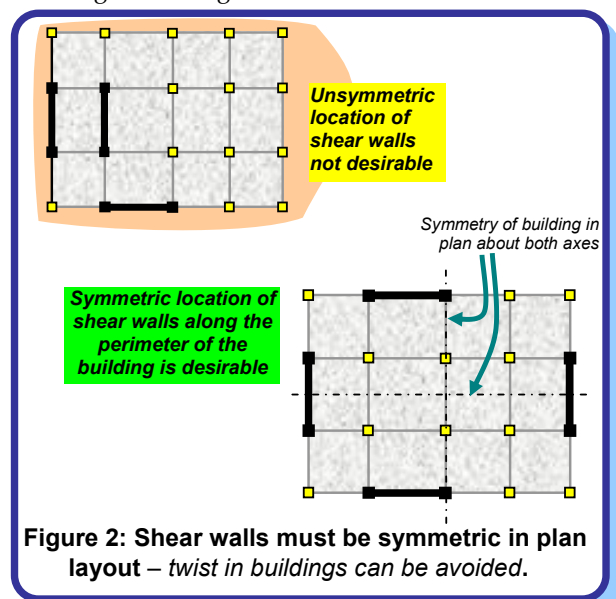

Figure 2: Shear walls must be symmetric in plan layout – twist in buildings can be avoided.

Why are Buildings with Shear Walls Preferred in Seismic Regions?

Ductile Design of Shear Walls

Just like reinforced concrete (RC) beams and columns, RC shear walls also perform much better if designed to be ductile. Overall geometric proportions of the wall, types and amount of reinforcement, and connection with remaining elements in the building help in improving the ductility of walls. The Indian Standard *Ductile Detailing Code* for RC members (IS:13920-1993) provides special design guidelines for ductile detailing of shear walls.

Overall Geometry of Walls: Shear walls are oblong in cross-section, i.e., one dimension of the cross-section is much larger than the other. While rectangular cross-section is common, L- and U-shaped sections are also used (Figure 3). Thin-walled hollow RC shafts around the elevator core of buildings also act as shear walls, and should be taken advantage of to resist earthquake forces.

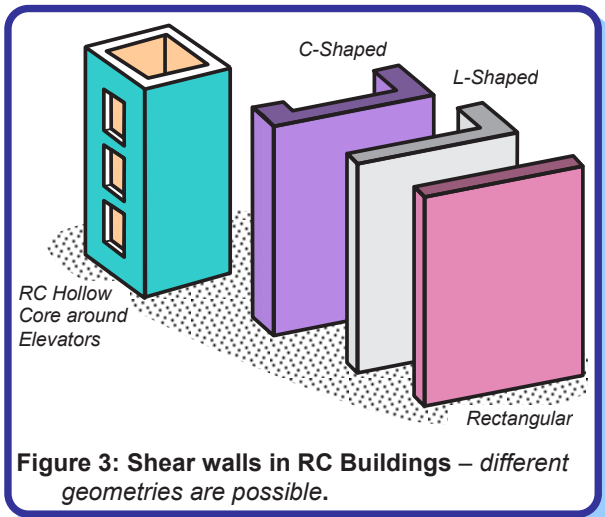

Reinforcement Bars in RC Walls: Steel reinforcing bars are to be provided in walls in regularly spaced vertical and horizontal grids (Figure 4a). The vertical and horizontal reinforcement in the wall can be placed in one or two parallel layers called curtains. Horizontal reinforcement needs to be anchored at the ends of walls. The minimum area of reinforcing steel to be provided is 0.0025 times the cross-sectional area, along each of the horizontal and vertical directions. This vertical reinforcement should be distributed uniformly across the wall cross-section.

Boundary Elements: Under the large overturning effects caused by horizontal earthquake forces, edges of shear walls experience high compressive and tensile stresses. To ensure that shear walls behave in a ductile way, concrete in the wall end regions must be reinforced in a special manner to sustain these load reversals without losing strength (Figure 4b). End regions of a wall with increased confinement are called boundary elements. This special confining transverse reinforcement in boundary elements is similar to that provided in columns of RC frames (See IITK-BMTPC Earthquake Tip 19). Sometimes, the thickness of the shear wall in these boundary elements is also

increased. RC walls with boundary elements have substantially higher bending strength and horizontal shear force carrying capacity, and are therefore less susceptible to earthquake damage than walls without boundary elements.

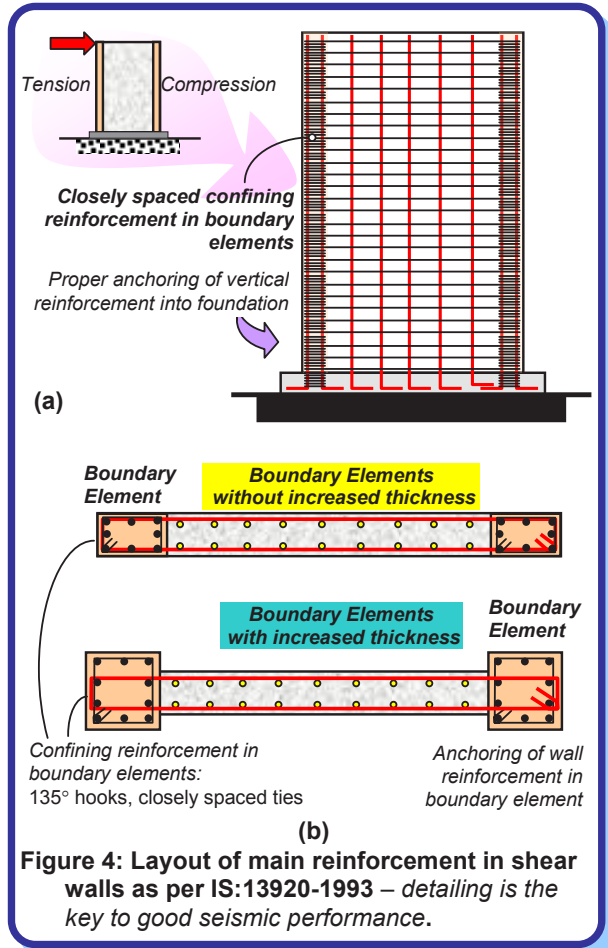

Related IITK - BMTPC Earthquake Tip

Tip 6: How Architectural Features Affect Buildings During Earthquakes?

Tip 19: How do Columns in RC Buildings Resist Earthquakes?

Resource Material

IS 13920, (1993), Indian Standard Code of Practice for Ductile Detailing of Reinforced Concrete Structures Subjected to Seismic Forces, Bureau of Indian Standards, New Delhi.

Paulay, T., and Priestley, M.J.N., (1992), *Seismic Design of Reinforced Concrete and Masonry Buildings*, John Wiley & Sons, USA

Next Upcoming Tip

How to Reduce Earthquake Effects on Buildings?

Authored by:
 C.V.R.Murty
 Indian Institute of Technology Kanpur
 Kanpur, India
 Sponsored by:
 Building Materials and Technology Promotion
 Council, New Delhi, India

This release is a property of IIT Kanpur and BMTPC New Delhi. It may be reproduced without changing its contents and with due acknowledgement. Suggestions/comments may be sent to: egtips@iitk.ac.in. Visit www.nicee.org or www.bmtpc.org, to see previous IITK-BMTPC Earthquake Tips.

How to Reduce Earthquake Effects on Buildings?

Why Earthquake Effects are to be Reduced

Conventional seismic design attempts to make buildings that do not collapse under strong earthquake shaking, but may sustain damage to non-structural elements (like glass facades) and to some structural members in the building. This may render the building non-functional after the earthquake, which may be problematic in some structures, like hospitals, which need to remain functional in the aftermath of the earthquake. Special techniques are required to design buildings such that they remain practically undamaged even in a severe earthquake. Buildings with such improved seismic performance usually cost more than normal buildings do. However, this cost is justified through improved earthquake performance.

Two basic technologies are used to protect buildings from damaging earthquake effects. These are *Base Isolation Devices* and *Seismic Dampers*. The idea behind *base isolation* is to detach (*isolate*) the building from the ground in such a way that earthquake motions are not transmitted up through the building, or at least greatly reduced. *Seismic dampers* are special devices introduced in the building to absorb the energy provided by the ground motion to the building (much like the way shock absorbers in motor vehicles absorb the impacts due to undulations of the road).

Base Isolation

The concept of base isolation is explained through an example building resting on frictionless *rollers* (Figure 1a). When the ground shakes, the rollers freely roll, but the building above does not move. Thus, no force is transferred to the building due to shaking of the ground; simply, *the building does not experience the earthquake*. Now, if the same building is rested on flexible pads that offer resistance against lateral movements (Figure 1b), then *some* effect of the ground shaking will be transferred to the building above. If the flexible pads are properly chosen, the forces induced by ground shaking can be a few times smaller than that experienced by the building built directly on ground, namely a *fixed base building* (Figure 1c).

The flexible pads are called *base-isolators*, whereas the structures protected by means of these devices are called *base-isolated buildings*. The main feature of the base isolation technology is that it introduces flexibility in the structure. As a result, a robust medium-rise masonry or reinforced concrete building becomes extremely flexible. The isolators are often designed to absorb energy and thus add damping to the system. This helps in further reducing the seismic response of the building. Several commercial brands of base isolators are available in the market, and many of

them look like large rubber pads, although there are other types that are based on sliding of one part of the building relative to the other. A careful study is required to identify the most suitable type of device for a particular building. Also, base isolation is not suitable for all buildings. Most suitable candidates for base-isolation are low to medium-rise buildings rested on hard soil underneath; high-rise buildings or buildings rested on soft soil are not suitable for base isolation.

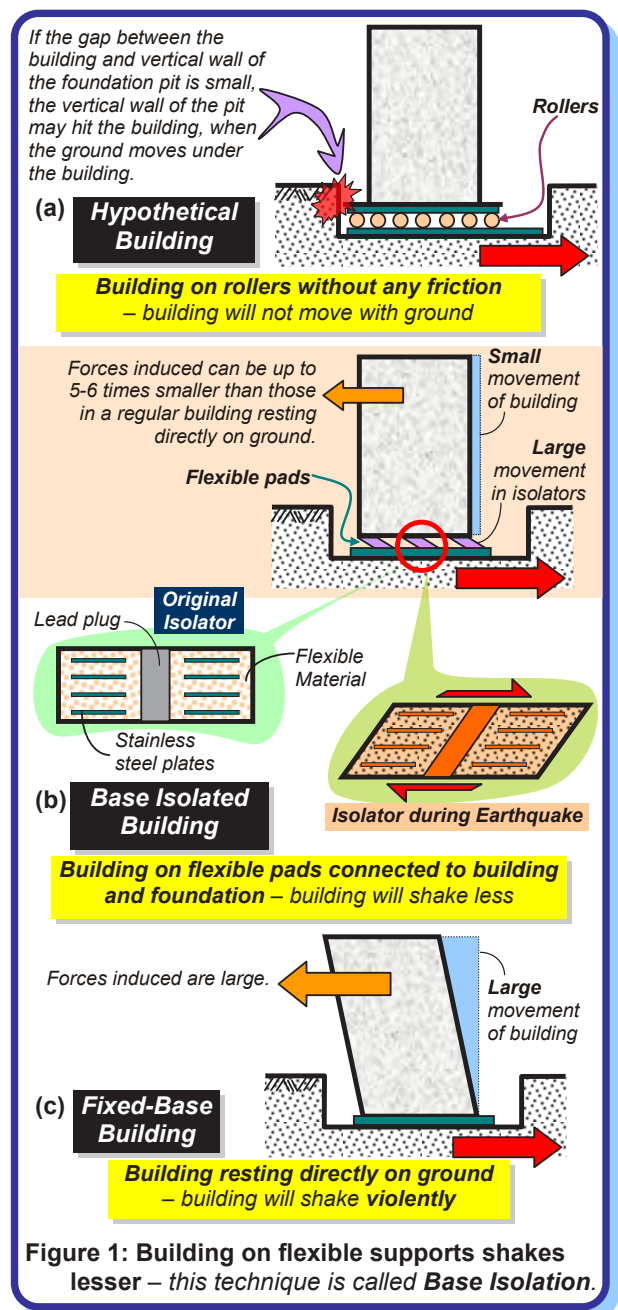

How to Reduce Earthquake Effects on Buildings?

Base Isolation in Real Buildings

Seismic isolation is a relatively recent and evolving technology. It has been in increased use since the 1980s, and has been well evaluated and reviewed internationally. Base isolation has now been used in numerous buildings in countries like Italy, Japan, New Zealand, and USA. Base isolation is also useful for retrofitting important buildings (like hospitals and historic buildings). By now, over 1000 buildings across the world have been equipped with seismic base isolation. In India, base isolation technique was first demonstrated after the 1993 Killari (Maharashtra) Earthquake [EERI, 1999]. Two single storey buildings (one school building and another shopping complex building) in newly relocated Killari town were built with rubber base isolators resting on hard ground. Both were brick masonry buildings with concrete roof. After the 2001 Bhuj (Gujarat) earthquake, the four-storey Bhuj Hospital building was built with base isolation technique (Figure 2).

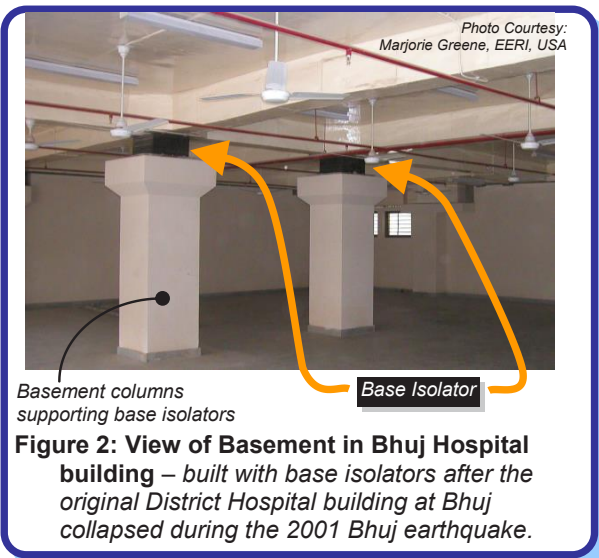

Seismic Dampers

Another approach for controlling seismic damage in buildings and improving their seismic performance is by installing seismic dampers in place of structural elements, such as diagonal braces. These dampers act like the hydraulic shock absorbers in cars – much of the sudden jerks are absorbed in the hydraulic fluids and only little is transmitted above to the chassis of the car. When seismic energy is transmitted through them, dampers absorb part of it, and thus damp the motion of the building. Dampers were used since 1960s to protect tall buildings against wind effects. However, it was only since 1990s, that they were used to protect buildings against earthquake effects. Commonly used types of seismic dampers include viscous dampers (energy is absorbed by silicone-based fluid passing between piston-cylinder arrangement), friction dampers (energy is absorbed by surfaces with friction between them rubbing against each other), and yielding dampers (energy is absorbed by metallic components that yield) (Figure 3). In India, friction dampers have been

provided in a 18-storey RC frame structure in Gurgaon (See <http://www.palldynamics.com/main.htm>).

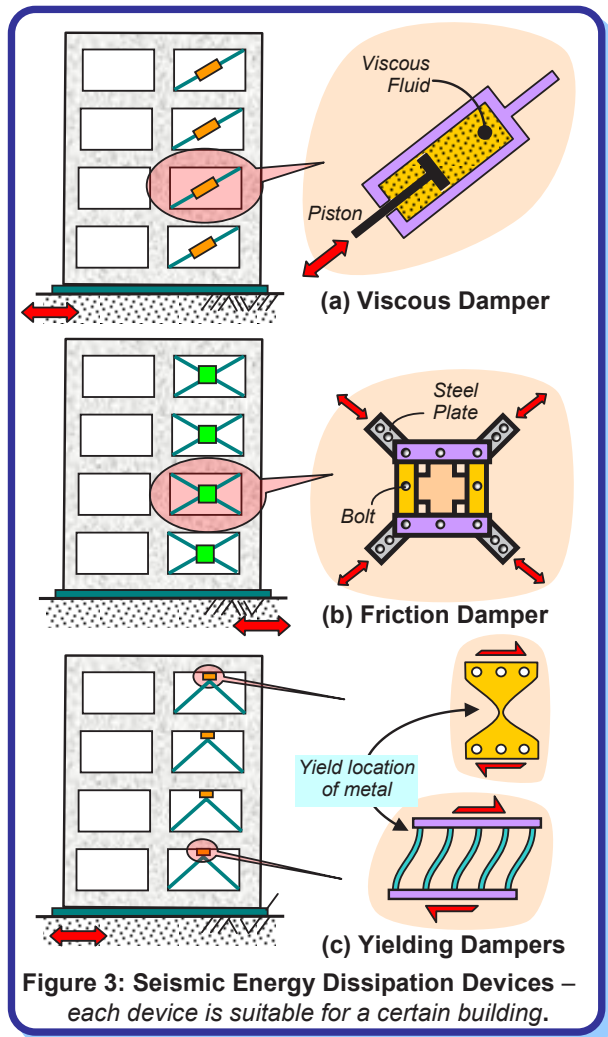

Related IITK - BMTPC Earthquake Tip

- Tip 5: What are the Seismic Effects on Structures?
- Tip 8: What is the Seismic Design Philosophy for Buildings?

Resource Material

EERI, (1999), *Lessons Learnt Over Time – Learning from Earthquakes Series: Volume II Innovative Recovery in India*, Earthquake Engineering Research Institute, Oakland (CA), USA; also available at http://www.nicee.org/readings/EERI_Report.htm.
 Hanson,R.D., and Soong,T.T., (2001), *Seismic Design with Supplemental Energy Dissipation Devices*, Earthquake Engineering Research Institute, Oakland (CA), USA.
 Skinner,R.I., Robinson,W.H., and McVerry,G.H., (1999), *An Introduction to Seismic Isolation*, John Wiley & Sons, New York.

Authored by:
 C.V.R.Murty
 Indian Institute of Technology Kanpur
 Kanpur, India
 Sponsored by:
 Building Materials and Technology Promotion
 Council, New Delhi, India

This release is a property of IIT Kanpur and BMTPC New Delhi. It may be reproduced without changing its contents and with due acknowledgement. Suggestions/comments may be sent to: eqtips@iitk.ac.in. Visit www.nicee.org or www.bmtpc.org, to see previous IITK-BMTPC Earthquake Tips.

Why are Load Paths Important in Buildings?

What are Load Paths?

Mass is present all through in a building - from roof parapet to foundation. Earthquake ground shaking induces inertia forces in a building where mass is present. These inertia forces are transferred downwards through horizontally and vertically aligned *structural elements* to foundations, which, in turn, transmit these forces to the soil underneath. The paths along which these inertia forces are transferred through building are *Load Paths* (Figure 1a). Buildings may have *multiple load paths* running between locations of mass and foundations. Load paths are as much a concern for transmitting vertical loads (e.g., self-weight, occupancy load, and snow; Figure 1b) as for horizontal loads (e.g., earthquake and wind; Figure 1c). Structural elements in buildings that constitute load paths include:

- Horizontal diaphragm elements laid in horizontal plane, i.e., roof slabs, floor slabs or trussed roofs and bracings;
- Vertical elements spanning in vertical plane along height of building, i.e., planar frames (beams and columns interconnected at different levels), walls (usually made of RC or masonry), & planar trusses;
- Foundations and Soils, i.e., isolated and combined footings, mats, piles, wells, soil layers and rock; and
- Connections between the above elements.

Importance of Load Paths

Buildings perform best in earthquakes, when inertia forces generated in them are transmitted to foundation by continuous and direct load paths *without being bent or interrupted*. When some structural elements are discontinued along a direct load path, loads have to bend and take detours to other load paths; buildings with *discontinuous or indirect load paths* are undesirable, because *brittle damage* can occur in structural elements at the interruptions or bends.

Horizontal Diaphragms

Floor and roof slabs are thin, wide structural elements laid in a horizontal plane at different levels. They transfer inertia forces induced by their own masses, to vertical elements on which they rest. During earthquake shaking, horizontal diaphragms act like *beams in their own horizontal plane* and transmit inertia forces to vertical elements, such as *structural walls* or *planar frames*. Slabs that are long in plan (i.e., flexible in their own plane), bend and undergo undesirable *stretching* along one edge and *shortening* along the other (Figure 2); they perform best when relative deformations are minimal and in-plane stiffness and strength sufficiently large. In general, slabs should be rectangular with *plan length/plan width ratio* less than 3.

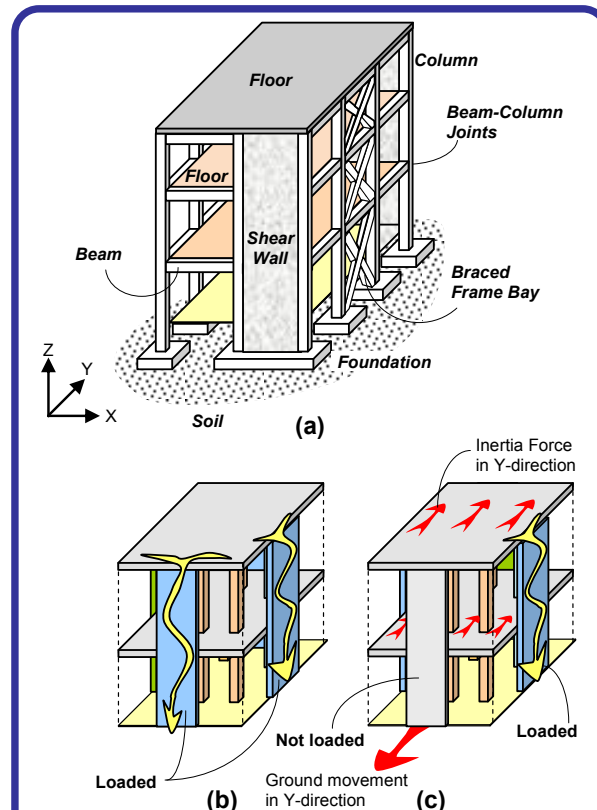

Figure 1: Load paths for different load actions – (a) key structural elements constituting load paths, (b) vertical load paths, and (c) lateral load paths

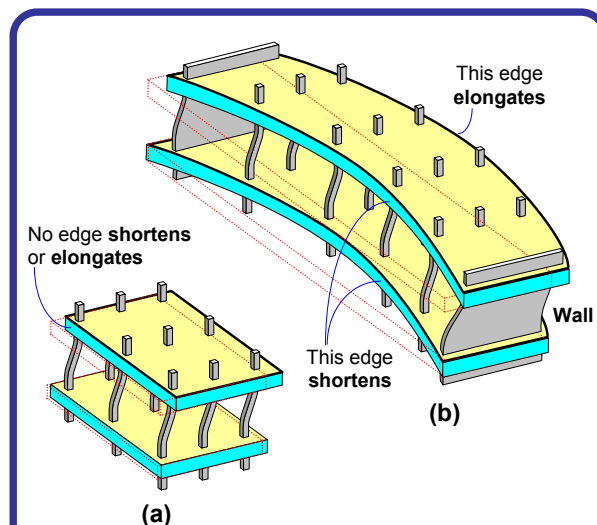

Figure 2: In-plane deformation in horizontal diaphragms – (a) absent, if plan aspect ratio is up to 3, and (b) present, if plan aspect ratio exceeds 5

Why are Load Paths Important in Buildings?

Horizontal floors can effectively resist and transfer earthquake forces through direct load paths, provided that they do not have significant openings. Large openings or cut-outs in floors interrupt load paths and may prevent smooth, direct transfer of forces to vertical elements. Openings in floors are necessary, e.g., to allow for elevator core or staircase to pass through. But, these should be as small as possible, and as few as possible. Their locations should be carefully considered; the ideal location for openings is close to center of floor slabs in plan.

Vertical Elements

Typical structural elements (present in vertical planes) of buildings are *columns*, *braces* and *structural walls* or a combination of these (Figure 3). They collect gravity and (*horizontal* and *vertical*) earthquake inertia forces from floor diaphragms at different levels, and bring them down to the foundations below.

It is possible to design and construct earthquake-resistant buildings with various structural systems, including *Moment Resisting Frames* (MRFs), *Frames with Brace Members* (called *Braced Frames* (BFs)), *Structural Walls* (SWs; also called *Shear Walls*), or a combination of these. Some of these systems require more advanced knowledge of design and higher quality control during construction than others, as reflected by their relative performance during earthquakes. For instance, buildings with SWs are easy to design and construct, and generally perform better during earthquakes, than buildings with MRFs alone.

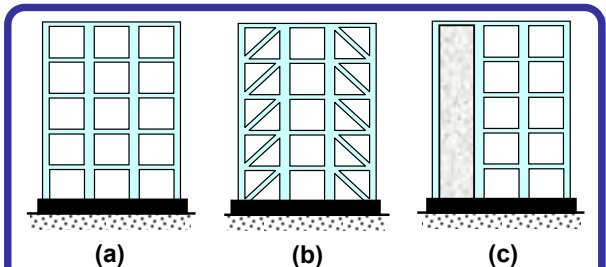

Figure 3: Structural systems in buildings that help resist lateral earthquake-induced inertia loads – (a) MRFs : moment-resisting frames, (b) BFs : braced frames, and (c) frame-wall dual systems

Key Requirements of Load Paths

Earthquake performances of buildings are determined by *soundness* of their load paths, independent of the material with which buildings are built, e.g., masonry, RC or structural steel. Earthquake codes require designers to ensure presence of adequate lateral load paths in buildings in two horizontal plan directions. Salient requirements of load paths are:

- (a) *Load paths must exist in all directions of a building:* Earthquake shaking occurs in all directions, and can be expressed as a combination of shaking in *one vertical* and *two (mutually perpendicular) horizontal directions*. Hence, adequate load paths are needed along the *vertical* and the two mutually perpendicular *horizontal directions*.

- (b) *Load path geometry must be simple:* Uninterrupted, direct load paths should be provided at regular intervals along length and width of the building;
- (c) *Load paths must be symmetrical in plan:* A building will sway uniformly in two horizontal directions, when structural elements constituting load paths are placed *symmetrically in plan*. Otherwise, it may twist about a vertical axis, which is detrimental to its earthquake performance.
- (d) *Robust connections are needed between structural elements along load paths:* In an earthquake-resistant structure, *every* connection is tested during *strong* earthquake shaking. These connections should be *stiff* and *strong* to offer continuous load paths without being damaged during strong earthquake shaking (Figure 4).



Photo Courtesy: Sudhir K. Jain

Figure 4: Deficient connection between slabs and vertical elements – collapse of an RC frame building during 2001 Bhuj (India) earthquake

Related IITK - BMTPC Earthquake Tip

Tip 5: What are seismic effects on structures?

Tip 6: How architectural features affect buildings during earthquakes?

Resource Material

Arnold,C., and Reitherman,R., (1982), *Building Configuration and Seismic Design*, John Wiley, USA
 Ambrose,J., and Vergun,D., (1999), *Design for Earthquakes*, John Wiley & Sons, Inc., USA

Authored by:

C.V.R.Murty

Indian Institute of Technology Jodhpur, India

Sponsored by:

Building Materials and Technology Promotion Council, New Delhi, India

This release is a property of IIT Kanpur and BMTPC. It may be reproduced without changing its contents with due acknowledgement. Suggestions or comments may be sent to: nicee@iitk.ac.in. To see all IITK-BMTPC Earthquake Tips, visit www.nicee.org or www.bmtpc.org.

What Harms Load Paths in Buildings?

Buildings with Moment Resisting Frames

Smooth transfer of inertia forces in a *Moment Resisting Frame* (MRF) building is critically dependant on the geometry of the frame grid. Some desirable features of a frame grid include:

- Several distinct planar, regular MRFs placed parallel to each other, in each of the two perpendicular plan directions of the building;
- Columns running through full height and beams through full width of the building;
- Uniform spacing between parallel planar MRFs in each plan direction; and
- Beams within each planar frame slender enough to deform in flexure: Concrete beams of very short span may damage in shear, which is undesirable.

Poor Frame Grid -

For smooth load transfer in an MRF, it is necessarily for beams and columns to intersect and to form a *well-defined grid*. Of the two MRF buildings shown in plan in Figure 1, the first one has regular frames in both plan directions (Figure 1a), while the second has irregular beam and column layout consisting of a small MRF in the X-direction and limited frame action in the Y-direction (Figure 1b); this is NOT an acceptable earthquake-resistant solution.

Large detours in load paths result in stress concentration in the frame and in poor performance. This can happen, if frame lines are discontinuous (*i.e.*, beam lines jog out-of-plane), and if beams frame into each other instead of into columns.

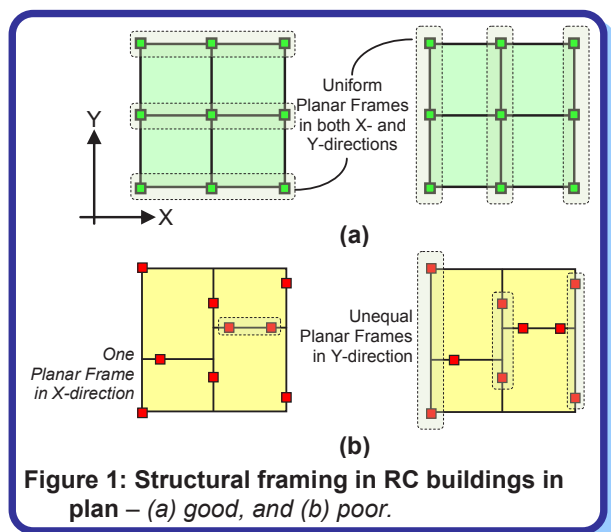

Figure 1: Structural framing in RC buildings in plan – (a) good, and (b) poor.

Discontinuity in Vertical Elements:

Floating Columns and Setback Columns -

Discontinuing a load carrying member along its length or height is *harmful* to earthquake performance of the building. It is not desirable to discontinue a

column in the lower storey of a building (Figure 2a); such columns are called *floating columns*. When a column is pushed out of the vertical line in a lower storey, the forces carried by the upper portion of the column have to bend at the setback location to continue towards the foundation (Figure 2b); such columns are called *setback columns*. Presence of a setback column also leads to poor building performance in an earthquake; brittle damage is expected in beam-column joints and beams adjoining the setback location.

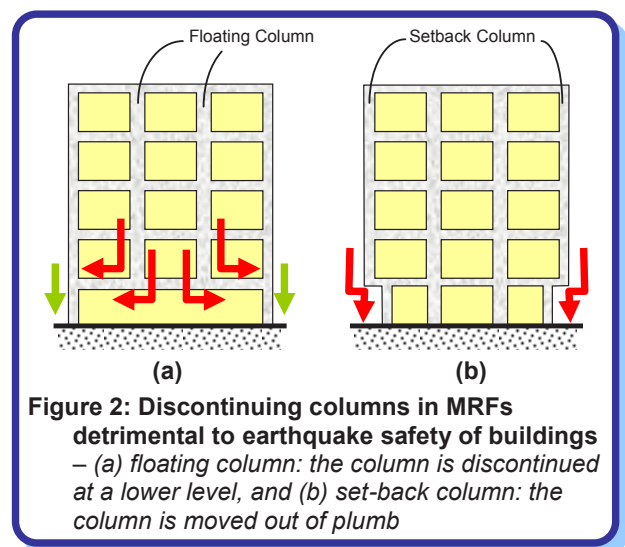

Figure 2: Discontinuing columns in MRFs detrimental to earthquake safety of buildings – (a) floating column: the column is discontinued at a lower level, and (b) set-back column: the column is moved out of plumb

Buildings with Structural Walls

Structural walls (SWs; also called *Shear Walls*) have large lateral stiffness and lateral strength in the length direction and provide very good load paths. Buildings with SWs have *performed well* during past earthquakes. Some desirable features of buildings with SWs include:

- Continuous SWs running through full building height generally offer direct load paths for inertia forces collected from diaphragms at different floor levels to be carried down to the foundation;
- Uniformly distributed SWs in both plan directions; and
- Sufficient wall density, *i.e.*, total cross-section area of structural walls in plan as a percentage of plan area of building.

Situations arise when departure occurs from good earthquake behaviour. These include:

(a) Large and/or irregular openings

SWs with smaller and uniform openings behave better (Figure 3a). In SWs with large and random openings, there are multiple load paths and each of those has long detours. As a result, the load paths become long and convoluted instead of being short

What Harms Load Paths in Buildings?

and direct (Figure 3b). This creates undesirable interrupted load transfer along the SW height. Design codes require special attention in the design and detailing of walls between openings, to reduce negative effects of openings and ensure desirable ductile behaviour of buildings with SWs.

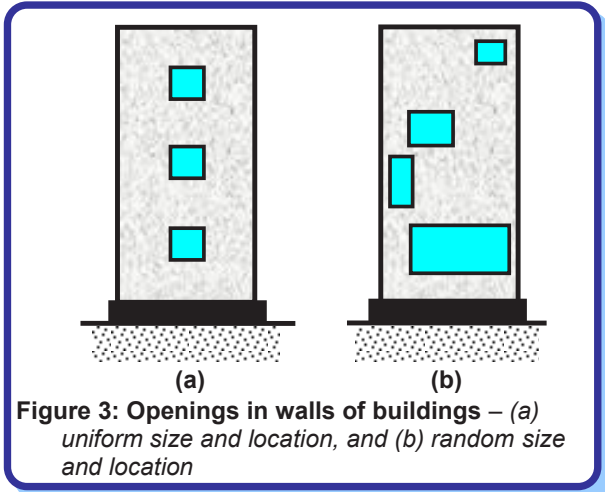

Figure 3: Openings in walls of buildings – (a) uniform size and location, and (b) random size and location

(b) Discontinuity, out-of-plane offsets and in-plane offsets in SWs in lower elevations

Sometimes, in the lower storeys of buildings, SWs are discontinued completely (Figures 4a and 5a), discontinued but moved *in-plane* (Figures 4b and 5b), or discontinued and moved *out-of-plane* (Figures 4c and 5c). This leads to abrupt changes in load path. Buildings with such wall configurations perform poorly in earthquakes. Such options should be avoided in earthquake-resistant buildings.

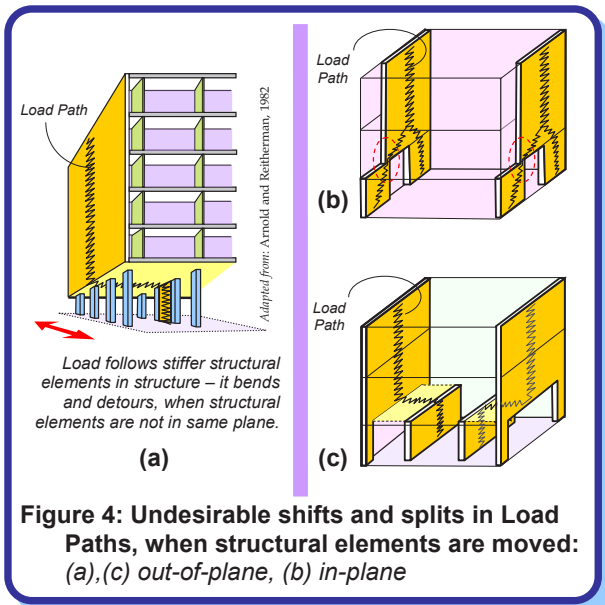

Figure 4: Undesirable shifts and splits in Load Paths, when structural elements are moved: (a),(c) out-of-plane, (b) in-plane

(c) Truncating structural walls in upper elevations

When SWs are discontinued at upper elevations over a part of their width (Figure 6a), or over the full width at a certain height (Figure 6b), abrupt changes occur in stiffness and strength of the building within a vertical plane. These practices should be avoided in earthquake-resistant buildings.

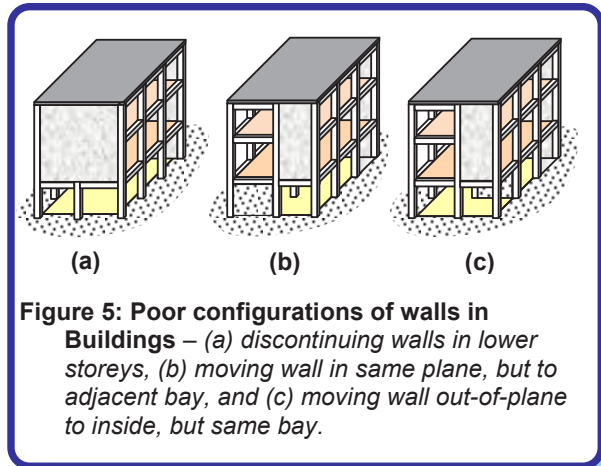

Figure 5: Poor configurations of walls in Buildings – (a) discontinuing walls in lower storeys, (b) moving wall in same plane, but to adjacent bay, and (c) moving wall out-of-plane to inside, but same bay.

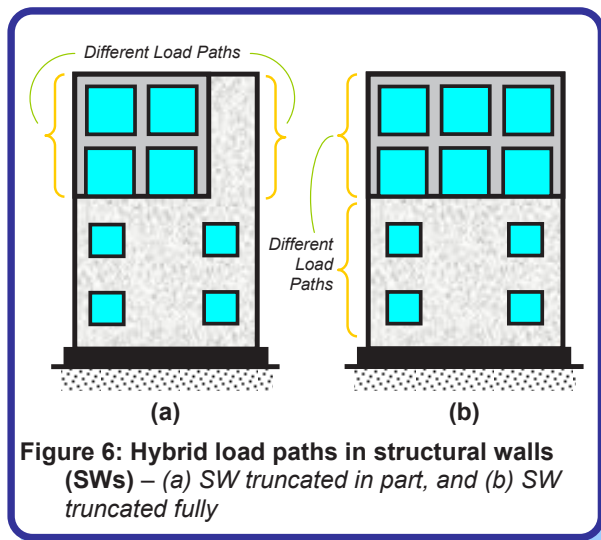

Figure 6: Hybrid load paths in structural walls (SWs) – (a) SW truncated in part, and (b) SW truncated fully

Related IITK - BMTPC Earthquake Tip

- Tip 7: How buildings twist during earthquakes?
- Tip 18: How do beams in RC buildings resist earthquake effects?
- Tip 20: How do beam-column joints in RC buildings resist earthquakes?
- Tip 21: Why are open ground storey buildings vulnerable in earthquakes?
- Tip 23: Why are buildings with shear walls preferred in seismic regions?

Resource Material

Arnold,C., and Reitherman,R., (1982), *Building Configuration and Seismic Design*, John Wiley, USA
 Ambrose,J., and Vergun,D., (1999), *Design for Earthquakes*, John Wiley & Sons, Inc., USA

Authored by:
 C.V.R.Murty
 Indian Institute of Technology Jodhpur, India
 Sponsored by:
 Building Materials and Technology Promotion
 Council, New Delhi, India

This release is a property of IIT Kanpur and BMTPC. It may be reproduced without changing its contents with due acknowledgement. Suggestions or comments may be sent to: nicee@iitk.ac.in. To see all IITK-BMTPC Earthquake Tips, visit www.nicee.org or www.bmtpc.org.

How can Non-structural Elements be protected against Earthquakes?

Non-Structural Elements

Structural Elements (SEs) in a building have a primary role of resisting the effects of earthquakes ground shaking, and of protecting life and property of building occupants. But, buildings contain many other items, such as *contents, appendages and services & utilities*, which are attached to and/or supported by SEs, and affected by earthquake ground shaking; these items are called *Non-Structural Elements* (NSEs).

NSEs can be classified into three groups, namely:

- (a) *Contents of buildings*: Items required for functionally enabling the use of spaces, such as (i) furniture and other items, *e.g.*, storage shelves, (ii) facilities and equipment, *e.g.*, refrigerators, multi-level material stacks, false ceilings, and (iii) door and window panels and frames, or ply board or aluminum partitions;
- (b) *Appendages to buildings*: Items projecting out from buildings, either horizontally or vertically, such as chimneys, exterior glass or stone cladding (*pasted* on the building surface as *façades*), parapets, small water tanks rested on top of buildings, sunshades, advertisement hoardings and communication antennas atop buildings;
- (c) *Services and utilities*: Items required for facilitating essential activities in the buildings, such as water mains, electricity cables, air-conditioning ducts, rainwater drain pipes, and elevators.

Earthquake Effects on NSEs

During strong earthquake shaking, NSEs can (a) *slide or topple*, or (b) *move or swing*, if they are not secured well to SEs of the building. These actions can cause loss to functionality of NSEs and potential secondary disasters, *e.g.*, spill of chemicals leading to laboratory fires (Figure 1a). Loss of functionality of an NSE can be small or substantive depending on its importance, the function it serves, and its cost. For instance, if book shelves of a library are not properly secured, they can distort (Figure 1b) or topple; the former may only dislodge books, but the latter can cause threat to life. If gas pipelines are pulled apart or electric control panels are toppled (Figure 1c), then both direct and indirect losses can be significant. With increasing sophistication in building systems, seismic performance of NSEs is becoming more important. In many earthquakes, economic losses due to damages in NSEs have been very substantial.

Protecting Non-Structural Elements

NSEs can demonstrate either *acceleration-sensitive* or *displacement-sensitive* behaviour during earthquakes.

- (a) *Acceleration-sensitive* NSEs may topple or slide, if

not anchored adequately to SEs (*e.g.*, a diesel generator unit on a floor, and expensive contents of museums). Thus, the SEs and the anchors by which NSEs are secured to SEs should be designed to resist the induced forces corresponding to the accelerations developed in these NSEs.

- (b) *Displacement-sensitive* NSEs may bend, compress or stretch by large amounts during earthquake shaking (*e.g.*, glass facades, water and gas pipes running between floors of a building, and electric lines running from a street pole to a building). Also, NSEs are significantly affected by the flexibility of SEs and their deformations. The connection of NSEs with SEs should be designed to accommodate *relative displacements* generated between support points on SEs with adequate slack.

Some NSEs are both *displacement* and *acceleration-sensitive*, and they have to be designed for both *forces* and *relative displacements*. For example, false ceilings suspended from floor slabs above, may not only pull out vertically from slabs, but also swing laterally and knock on walls.

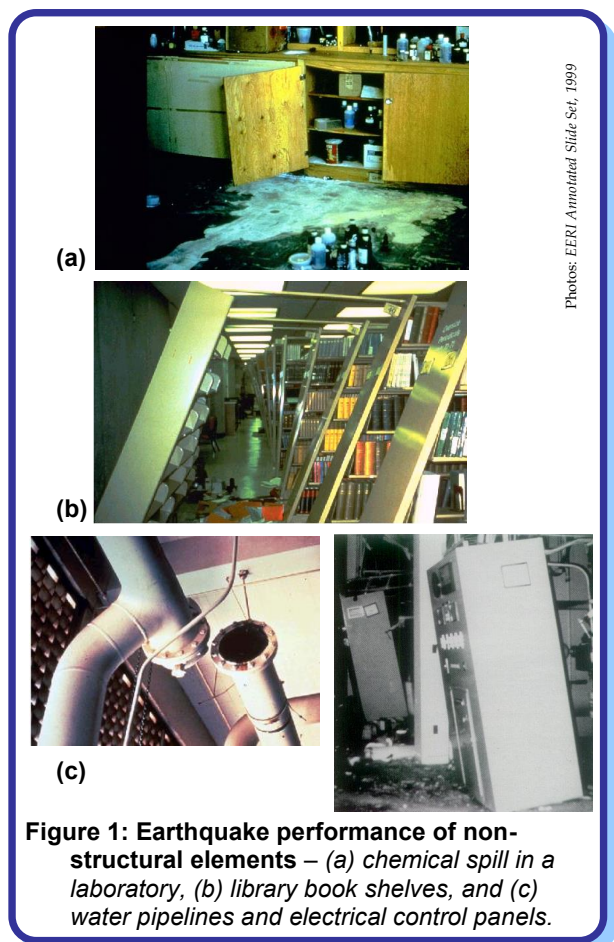

Figure 1: Earthquake performance of non-structural elements – (a) chemical spill in a laboratory, (b) library bookshelves, and (c) water pipelines and electrical control panels.

Three strategies are adopted for design of NSEs in a building and their connections with SEs, namely:

- (i) *Non-Engineered Strategy*: generic NSEs (e.g., glass bottles on shelves, and crockery) cannot be individually secured, but can be protected with simple strategies (e.g., hold-back strings) (Figure 2);
- (ii) *Prescriptive Strategy*: factory-made, reasonably large NSEs (e.g., cupboards, refrigerators, laboratory equipment and large panel glass windows) often have manufacturer prescribed protection or anchorage details provided at the time of purchase (Figure 3), and
- (iii) *Engineered Design Strategy*: large, specialised, massive NSEs (e.g., cooling plant of central air-conditioning systems, billboards) and those whose failure can be critical (e.g., fire hydrant pipes running along building height) require formal design calculations for protecting them (Figure 4).

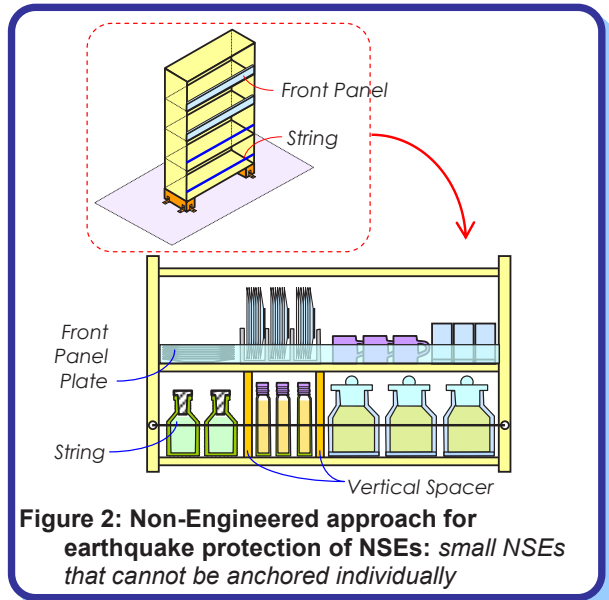

Figure 2: Non-Engineered approach for earthquake protection of NSEs: small NSEs that cannot be anchored individually

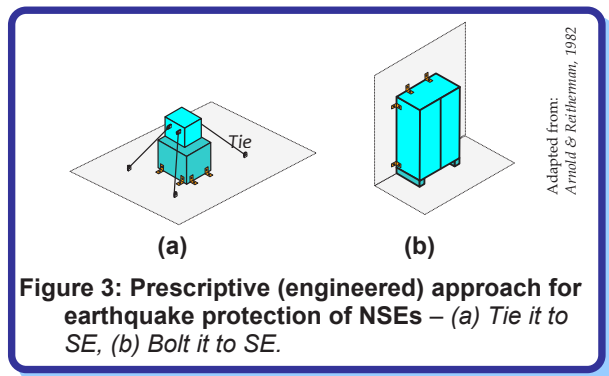

Figure 3: Prescriptive (engineered) approach for earthquake protection of NSEs – (a) Tie it to SE, (b) Bolt it to SE.

NSEs located in upper levels of buildings and their connections to SEs must be designed for shaking expected at those floor levels (Figure 5); this floor shaking can be different and even of higher intensity than the shaking at the ground level. Hence, NSEs that project vertically or horizontally from buildings at the upper elevations needs special attention. Some countries (e.g., USA) have provisions for *engineered design* of NSEs and their connections with SEs.

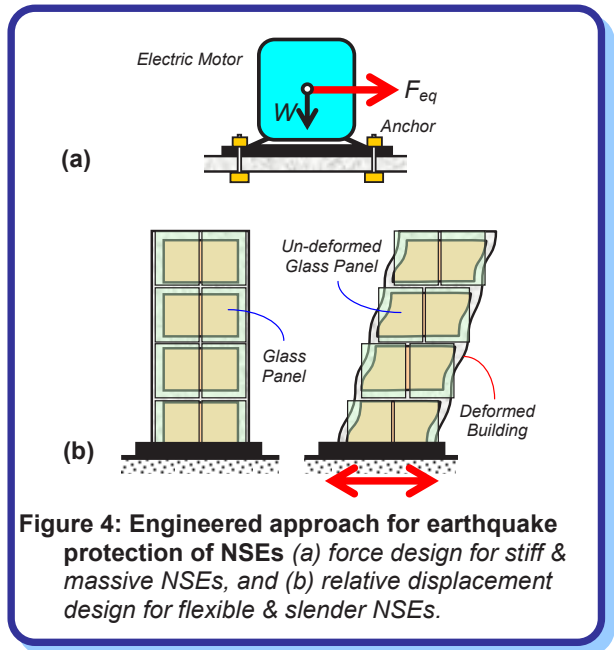

Figure 4: Engineered approach for earthquake protection of NSEs (a) force design for stiff & massive NSEs, and (b) relative displacement design for flexible & slender NSEs.

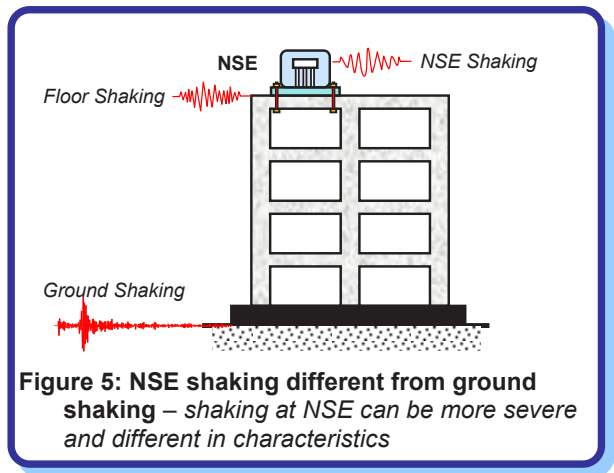

Figure 5: NSE shaking different from ground shaking – shaking at NSE can be more severe and different in characteristics

Related IITK - BMTPC Earthquake Tip

Tip 23: Why are buildings with shear walls preferred in seismic regions?

Resource Material

FEMA E-74, (2011), *Reducing the Risks of Non-structural Earthquake Damage - A Practical Guide*, Applied Technology Council, USA
 Mondal,G., and Jain,S.K., (2005), "Design of Non-Structural Elements for Buildings: A review of codal provisions," August 2005; and "Proposed Draft for IS:1893 on Design of Non-Structural Elements," October 2005, *The Indian Concrete Journal*, ACC Limited, Thane, India

Authored by:
 C.V.R.Murty
 Indian Institute of Technology Jodhpur, India
 Sponsored by:
 Building Materials and Technology Promotion Council, New Delhi, India

This release is a property of IIT Kanpur and BMTPC. It may be reproduced without changing its contents with due acknowledgement. Suggestions or comments may be sent to: nicee@iitk.ac.in. To see all IITK-BMTPC Earthquake Tips, visit www.nicee.org or www.bmtpc.org.

What is a Confined Masonry Construction?

Basics of Confined Masonry

Confined Masonry (CM) construction typically consists of: traditional *strip foundation* (in masonry); reinforced concrete (RC) *plinth beam*; masonry walls (in bricks or concrete block units) built on top of plinth beam; small RC *vertical & horizontal confining elements* built around these masonry walls; and RC *floor and roof slabs* built monolithically with the confining elements (Figure 1a). These vertical and horizontal confining elements are called *tie-columns* and *tie-beams*, respectively. CM construction has a mandatory *plinth beam* on top of plinth masonry. CM is a good construction technology for *low- and medium-rise* houses in seismic areas (Figure 1b).

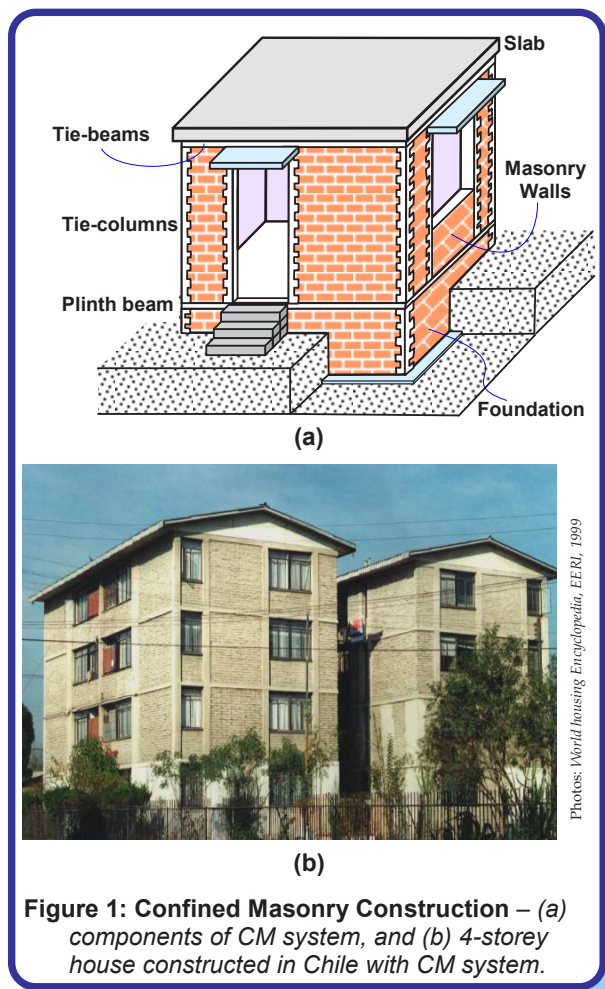

Figure 1: Confined Masonry Construction – (a) components of CM system, and (b) 4-storey house constructed in Chile with CM system.

Construction of CM building with RC *confining elements* involves making masonry walls in small panels, each of which is confined on all four sides by vertical and horizontal RC elements. Concrete is poured in vertical and horizontal confining elements

after walls are built. RC confining elements hold the masonry in place and improve integrity of the house during seismic shaking (Figure 2). CM houses performed well even in several severe earthquakes, such as the 2010 Chile earthquake (Magnitude 8.8), while many unreinforced masonry (URM) and even RC buildings suffered damage during the same events.

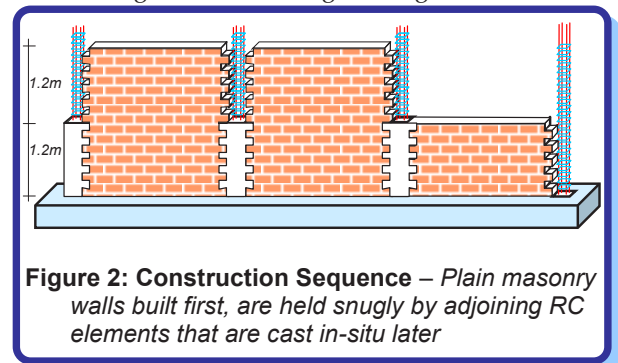

Figure 2: Construction Sequence – Plain masonry walls built first, are held snugly by adjoining RC elements that are cast-in-situ later

The concept of masonry wall construction confined with wood elements has been used for centuries in many earthquake-prone regions along the *Alpine-Himalayan belt*. For example, in the Kashmir Valley in J&K State (India), *Dhajji Dewari* constructions consists of large masonry walls broken into smaller panels with wood verticals, horizontals and diagonals. These houses showed *excellent* performance in many past earthquakes and helped avoid loss of life. These houses have simple architectural design, good quality materials and good quality of construction.

CM is different from MRF with URM Infills

CM houses are different substantially from RC *moment resisting frame* (MRF) houses with masonry infills, even though both technologies use the same constituent structural materials (concrete and masonry) and have very similar appearance when the buildings are completed. The key differences are:

(a) Different Behaviour:

CM houses are *load-bearing structures*, because *masonry walls* carry both *gravity* and *earthquake-induced lateral forces*. This is similar to *unreinforced masonry* (URM) construction, which has been used in India for many centuries. URM houses perform well under gravity loads, but experience significant damage during earthquake shaking, because masonry cannot take tension that develops during earthquake shaking. On the other hand, RC MRF houses classify under *moment-resisting frame system*. RC frames are infilled with unreinforced masonry walls in some countries, e.g., India (see *IITK-BMTPC Earthquake Tips 17, 21 and 22*), and with engineered infills in others, e.g., New Zealand.

What is a Confined Masonry Construction?

(b) Different Construction Sequence:

Construction sequence is distinctly different for the two construction types, namely CM and MRF with masonry infills. In CM construction, masonry walls are built simultaneously with reinforcement in vertical and horizontal RC confining elements, and concrete is poured in these elements at the end (Figure 3a). In RC MRF construction with masonry infills, first the RC frame is built (i.e., footings, columns, beams, and slabs) and then the masonry wall panels are infilled in open bays between RC columns and beams (Figure 3b).

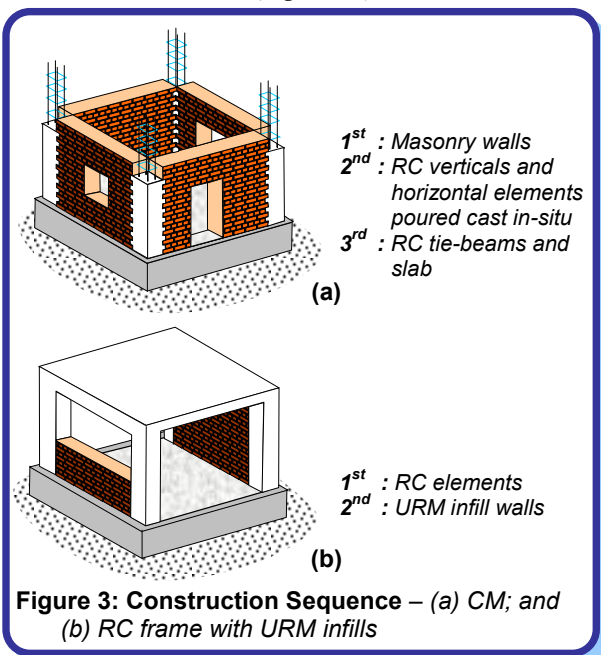

(c) Different Design Complexity:

In CM houses, RC elements act primarily in compression and tension (similar to posts in wood construction), and the connections between these elements are pinned (there is no flexure); hence, RC tie-beams and tie-columns are smaller in size and require less reinforcement compared to RC frame members. In RC MRF houses, RC members largely undergo bending and shearing, and therefore they need to be larger in terms of size and amount of reinforcement. Prescriptive approach may be adequate for design of low-rise CM houses with typical room sizes and floor heights (See Meli et al, 2011; Brzev, 2008), but engineered design approach is required for RC MRF houses. Thus, design effort may be considerably smaller for CM houses than for RC MRF houses.

RC confining elements in CM construction (Figure 4) enhance stability and strength of brittle masonry walls, e.g., interaction between masonry walls, structural integrity, and containment of earthquake damage within the masonry walls. These advantages lead to superior (more ductile) earthquake performance of CM houses over those of alternative concrete and masonry building technologies, with relatively lower level of technical effort. Also, CM houses are more

economical for the same functional use. For these reasons, confined masonry construction is more suitable for low- and medium-rise housing in earthquake prone areas than for RC MRF construction.

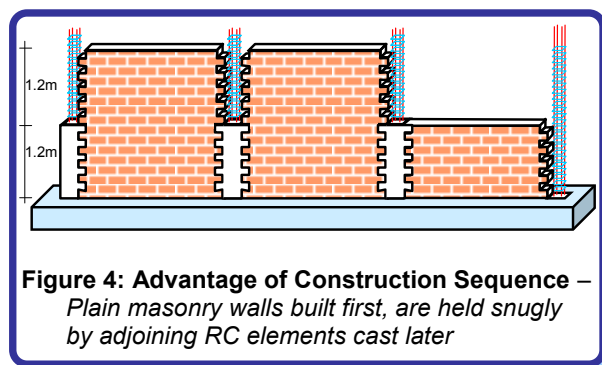

Construction of Buildings with Confined Masonry

Design Codes for CM houses have been in place for more than 50 years in several countries, like Chile, Mexico and Argentina. But, CM construction has not been practiced in many countries, including India; hence, code provisions were not available in these countries for many years, but now some are being developed (See Brzev, 2008; Schacher, 2009). Most design codes lay down prescriptive guidelines for architectural, structural and constructional aspects of low-rise CM buildings, and provide requirements for engineered design of tall CM buildings. These design codes are based on experimental verification in laboratories, analytical research as well as earthquake performance of such constructions in past earthquakes.

Related IITK - BMTPC Earthquake Tips

Tip 12: How do brick masonry buildings behave during earthquakes?

Tip 13: Why should masonry buildings have simple structural configuration?

Tip 17: How do earthquakes affect reinforced concrete buildings?

Tip 29: What are the essential features of confined masonry houses?

Resource Material

Brzev, S.N., (2008), *Earthquake-Resistant Confined Masonry Construction*, National Information Center of Earthquake Engineering, IIT Kanpur, www.nicee.org

Meli, R., et al (2011), *Seismic Design Guide for Low-Rise Confined Masonry Buildings*, Earthquake Engineering Research Institute, and International Association for Earthquake Engineering

Schacher, T., (2009), *Confined Masonry for one and two storey buildings in low-tech environments*, A guidebook for technicians and artisans, National Information Center of Earthquake Engineering, IIT Kanpur, www.nicee.org

Authored by:

C.V.R.Murthy

Indian Institute of Technology Jodhpur, India

Sponsored by:

Building Materials and Technology Promotion Council, New Delhi, India

This release is a property of IIT Kanpur and BMTPC. It may be reproduced without changing its contents with due acknowledgement. Suggestions or comments may be sent to: nicee@iitk.ac.in. To see all IITK-BMTPC Earthquake Tips, visit www.nicee.org or www.bmtpc.org.

What are the Essential Features of Confined Masonry Houses?

Scope of Construction of Buildings with Confined Masonry

Confined Masonry (CM) system is *suitable* for construction of *low-* and *medium-rise* buildings, and can be implemented with relatively lower engineering inputs and technical supervision. Some countries permit construction of CM houses of up to six storeys tall, supported by *design codes* and *engineering inputs*. CM system is *not intended* for use in the construction of commercial buildings or large span buildings.

Architectural Guidelines

Architectural configuration critically determines overall earthquake behaviour of CM houses.

(a) Overall Geometry

The overall shape of houses should be regular in both plan and elevation. Best performance is achieved in CM buildings, when, in plan, they (i) are rectangular, (ii) have no significant re-entrant corners and no interior cut-outs, and (iii) have plumb vertical walls along the entire building perimeter (Figure 1a). Buildings with re-entrant corners, cut-outs, vertical offsets and large cantilever overhangs (Figure 1b) perform poorly during earthquakes.

Plan aspect ratio, i.e., ratio of longer and shorter plan dimension (L/B), of a CM house should not exceed 4 (Figure 2); seismic gap can be used in buildings with elongated plan shapes. Typical storey height should not exceed about 3m. Even though buildings up to 6 storeys high have been built in *high seismic regions* in Mexico, Chile and Peru, the recommended maximum number of storeys is 4, 3 and 2 in seismic zones III, IV and V of India, respectively (for now as design codes are unavailable) (Figure 2).

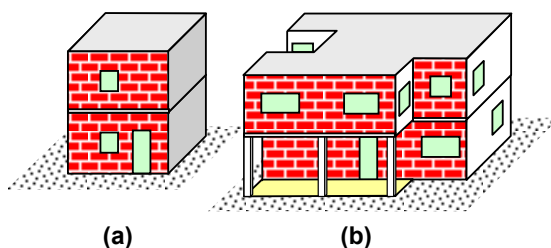

Figure 1: Overall geometry features – (a) desirable regular building, and (b) undesirable irregular building

(b) Wall Configuration

Walls in a CM house should be aligned preferably on a rectangular grid that is symmetrical in plan (Figure 3). Further, all walls must run through from the base of the building to the roof, without being terminated at any intermediate level.

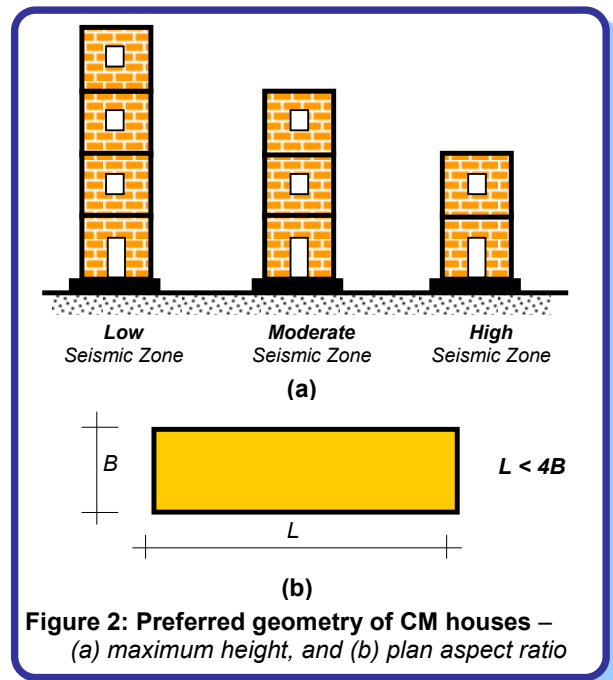

Figure 2: Preferred geometry of CM houses – (a) maximum height, and (b) plan aspect ratio

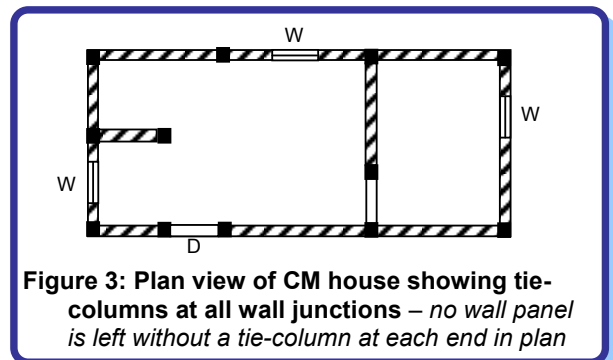

Figure 3: Plan view of CM house showing tie-columns at all wall junctions – no wall panel is left without a tie-column at each end in plan

Openings in walls deteriorate earthquake performance of CM buildings. Hence, openings should ideally be kept to a minimum in number and size. Larger openings must be confined by cast-in-situ RC elements all around, otherwise a wall with large openings is considered as unconfined. Openings in all storeys must be positioned at the same location along the height of the building.

Structural Guidelines

Wall thickness required in a building will depend on loads and masonry strength. This should be carefully checked. Masonry walls should be at least *110 mm* thick; their height should not exceed *25 times* thickness. Storey height should not exceed *3 m*, even if thicker walls are used. Ideally, all masonry walls should be *fully-confined* with RC tie-columns on both sides of openings and at wall intersections, and RC tie-

What are the Essential Features of Confined Masonry Houses?

beams above and below it. Earthquake behaviour improves with the number of *fully-confined* masonry walls. For good earthquake behavior, at least a reasonable wall density should be available of *fully confined masonry* (as a percentage of plinth area of the building) in each plan direction of the building; this depends on a number of factors including the expected ground acceleration, number of storeys, and masonry compressive and shear strength. This reasonable wall density varies from 2% to 5%. Minimum depth (height) of RC plinth beams should be 300 mm.

Many options have been practiced with regard to foundations of CM houses, namely RC tie-column starts from (1) plinth beam (house has no foundation beam), (2) foundation beam (house has plinth beam), and (3) foundation PCC (house has no foundation beam, but plinth beam is used). Option (3) is used commonly (Figure 4).

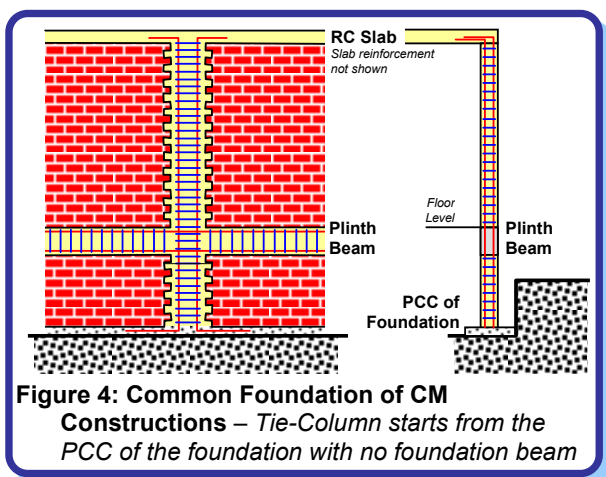

Figure 4: Common Foundation of CM Constructions – Tie-Column starts from the PCC of the foundation with no foundation beam

RC tie-columns should be as wide as the thickness of masonry wall, say 230mm in standard burnt clay brick masonry walls in India, although half brick walls are used in many countries, including Mexico and Indonesia. Usually, RC tie-columns provided at wall junctions should be square in cross-section (say 230×230mm), while RC tie-columns adjacent to openings should be as deep as the wall thickness, but may be less wide in the wall direction (say 115×230 mm). Proper connections are essential between RC tie-columns and tie-beams, and between tie-beams meeting at wall corners (Figure 5).

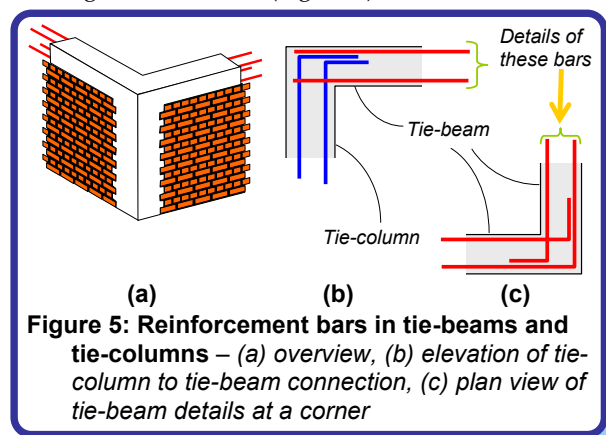

Figure 5: Reinforcement bars in tie-beams and tie-columns – (a) overview, (b) elevation of tie-column to tie-beam connection, (c) plan view of tie-beam details at a corner

In tie-columns, at least 4 deformed steel bars of 10 mm diameter should be provided, and tied with 6 mm diameter mild steel ties at 200 mm centers (Figure 6a); closely spaced ties are required in top and bottom portion of a tie-column, with spacing of 100 mm. Ties should have 135° hook ends. In RC tie-beams, minimum reinforcement to be provided is somewhat similar.

Constructional Guidelines

Using quality materials, ensuring good workmanship and faithfully implementing architectural and structural guidelines are vital in construction of CM buildings. For improved earthquake performance, the interface between masonry walls and tie-columns should be toothed, *i.e.*, bricks of masonry courses are staggered at the interface with tie-columns (Figure 5a). This ensures that masonry walls are held snugly between tie-columns. Toothing should be such that the minimum gap from bars of tie-column is 25mm to the nearest brick face and 75mm to the farthest brick face.

Maximum vertical lift per day of masonry walls should be 1.2 m. And, concrete for the tie-columns should be poured before the next lift of 1.2 m of masonry wall is built. This ensures that concrete in tie-columns is reasonably compacted, especially when it is hand compacted.

The formwork is butted against the masonry wall segment for pouring concrete in tie-columns of CM construction. This is the main strength of this construction – snug fit between masonry walls and concrete poured in-situ after the masonry walls are in place. Hence, significant care is required in preparing the formwork (made of wood or steel) and ensuring that gaps are plugged between masonry walls and formwork, before pouring the in-situ concrete of tie-columns.

Related IITK - BMTPC Earthquake Tip

Tip 12: How do Masonry Houses Behave during Earthquakes?
Tip 28: What is confined masonry construction?

Resource Material

Brzev, S.N. (2008), *Earthquake-Resistant Confined Masonry Construction*, NICEE, IIT Kanpur, www.nicee.org
Meli, R., et al. (2011), *Seismic Design Guide for Low-Rise Confined Masonry Buildings*, EERI and IAEE, www.confinedmasonry.org
Blondet, M. (Ed.) (2005), *Construction and Maintenance of Masonry Houses – for Masons and Craftsmen*, Earthquake Engineering Research Institute (USA), Pontificia Universidad Católica del Perú (Peru) and SENCICO, (Peru)

Authored by:

C.V.R. Murty

Indian Institute of Technology Jodhpur, India

Sponsored by:

Building Materials and Technology Promotion Council, New Delhi, India

This release is a property of IIT Kanpur and BMTPC. It may be reproduced without changing its contents with due acknowledgement. Suggestions or comments may be sent to: nicee@iitk.ac.in. To see all IITK-BMTPC Earthquake Tips, visit www.nicee.org or www.bmtpc.org.

What is Important in Foundations of Earthquake-Resistant Buildings?

Selecting Site for Earthquake-Resistant Buildings

The site of a building should be free from any collateral damage due to earthquake-related effects. Ideal sites are:

- Away from a potential *fault rupture zone*;
- Above the level of *inundation under tsunami waves* generated in the adjoining ocean by earthquakes (Figure 1);
- Beyond the forest or wooded areas with potential *fire hazard* arising from earthquakes; and
- Free from detrimental earthquake actions in the ground, like *liquefaction*, *settlement* and *lateral spreading* (See IITK-BMTPC Earthquake Tip 31).

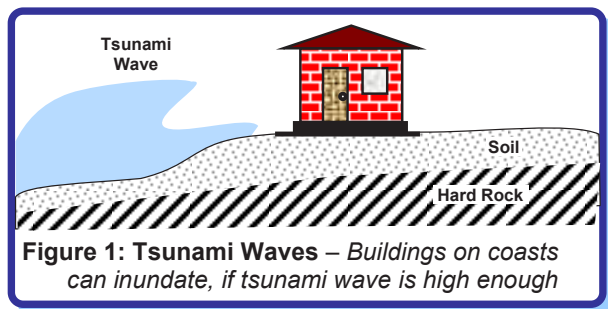

Even if the site is devoid of the above, steep slopes or vertical cuts in natural hills (otherwise safe under other loads acting on them) can slide during earthquakes (Figure 2). Vulnerable soil embankments can *slide* or *spread laterally* due to liquefaction. Other earthquake hazards at hill slope sites include *rolling stones* and *debris*. When the ground shakes underneath *buildings with elongated plan* or *long span structures* (e.g., suspension bridges), the motion at different supports may not be *synchronous*. Differential shaking of such structures at their supports induces additional effects, and should be accounted for in their design.

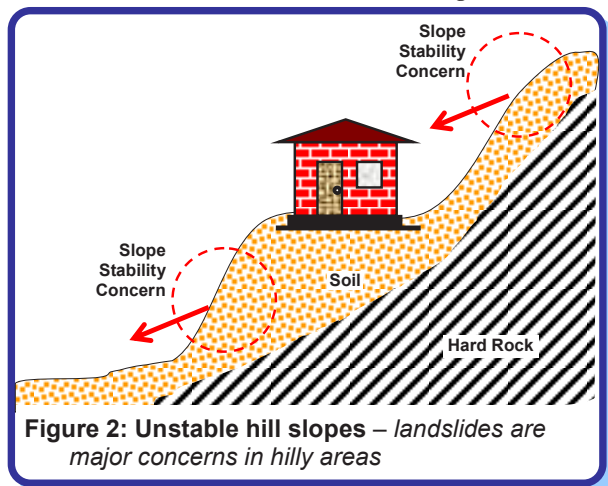

Effect on Ground Shaking on Building Site

Even if local soil stratum underneath a proposed structure is stable, ground shaking may be modified when earthquake waves propagate through the soil overlying rock layers; this phenomenon is referred to as *Site Effect*. Even when shaking at the base rock is *moderate*, the motion at a site may be amplified by soil above rock, and this needs to be accounted for in design. *Site effect* was noticed first in the 1819 Kutch earthquake in India. It was very prominent in 1985 earthquake that affected Mexico City; ground response was amplified by up to 7-8 times at building sites located on lake bed (which was akin to a bowl of jelly) in contrast to those located on hard rock (Figure 3) in Mexico City. *Peak Ground Acceleration* (PGA) is a measure of severity of shaking of ground. During the 1985 earthquake, PGA at soft soil site (SCT) was significantly larger than at rocky site (UNAM) (Figure 3b).

Amplification of ground motion depends on soil properties (e.g., shear modulus, damping, soil layers and their properties, saturated *versus* dry soil, and loose *versus* dense soil), and ground motion characteristics. In general, stiff soils have lower amplification, while soft soils higher. Seismic design codes provide design spectra for underlying soil strata of different soil types.

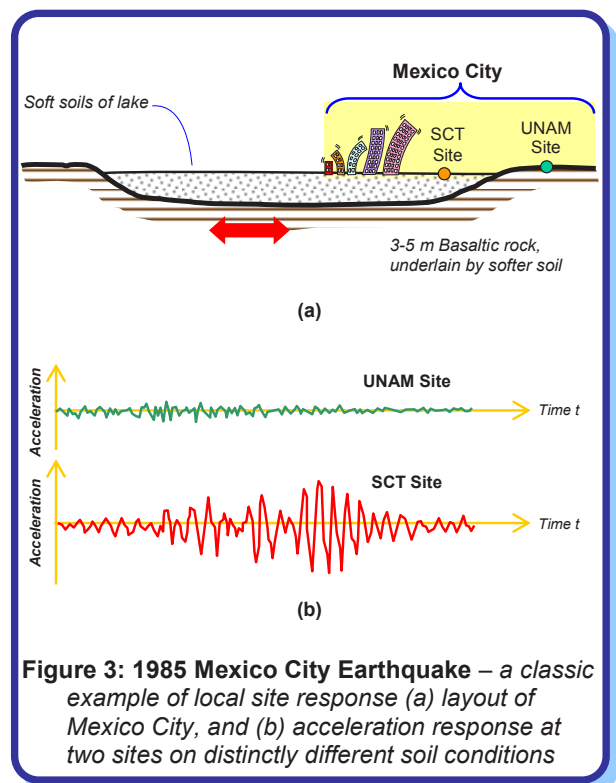

Figure 3: 1985 Mexico City Earthquake – a classic example of local site response (a) layout of Mexico City, and (b) acceleration response at two sites on distinctly different soil conditions

Seismic Design of Foundations

No structure can perform well, if it does not have a good foundation supported on strata that is stable during earthquakes. All principles applicable in foundation design of structures subjected to gravity loads, are applicable in foundation design of earthquake-resistant structures also. Concepts of foundation engineering, like *Bearing Capacity* and *Settlement Criteria*, are relevant to earthquake-resistant buildings also. Thorough geotechnical investigations at the site are a must for most design projects. In addition to traditional *Standard* and *Cone Penetration Tests*, other in-situ tests (e.g., *Shear Wave Velocity Test* and *Pressure-meter Test*) may be performed.

Depending on geotechnical conditions, structural configuration and loads, a suitable type of foundation must be chosen. If soil type is hard, isolated footings may suffice under individual columns. But, these foundations must be tied to each other with beams at top of footings or within the footing depth to resist relative movement between column bases (Figure 3). On the other hand, if soil underneath is soft, other foundation types may become necessary, e.g., raft or pile foundations.

If the site is susceptible to liquefaction, either ground improvement must be undertaken or the foundation must be carefully designed, such that it can carry the load even after the vulnerable soil layers have liquefied (Figure 4). For instance, in case of pile and well foundations, layers susceptible to liquefaction should be neglected in estimating stiffness and strength of the soil system.

In case of lateral spreading, investigations beyond the property boundaries (lines) of the building under consideration may become necessary, especially in when plots are small. Also, lateral thrust offered by liquefied soil layers must be included in estimating force demands on foundations.

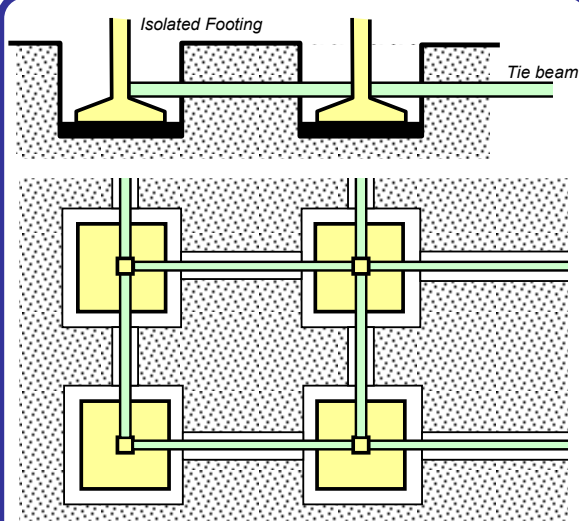

Figure 3: Good foundation design practice in non-liquefiable soil conditions – RC tie-beams between columns at the top of the isolated footings

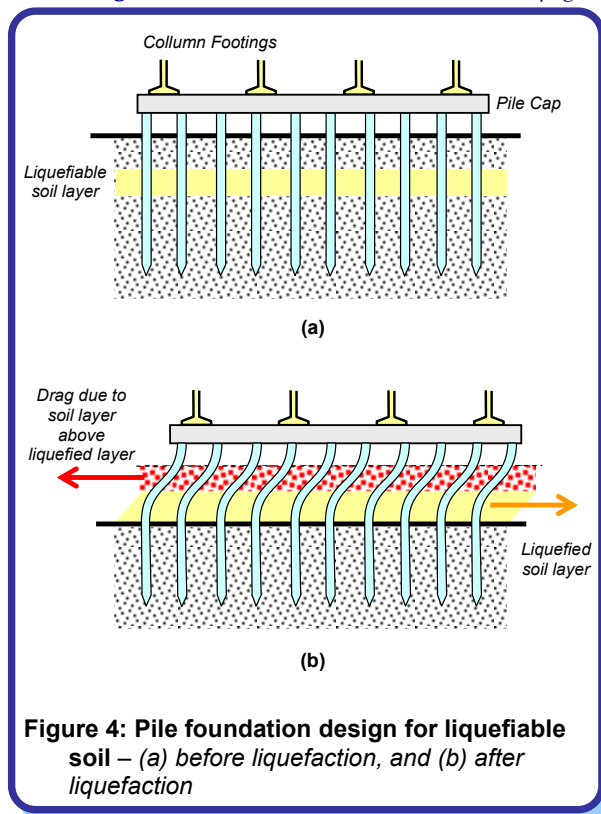

Figure 4: Pile foundation design for liquefiable soil – (a) before liquefaction, and (b) after liquefaction

Capacity Design of Foundations

It is difficult to inspect and repair foundations after a severe earthquake. Further, damage to foundation can be detrimental to the stability of the structure. Hence, in seismic design, column damage in columns is preferred over foundation damage during strong shaking. This is achieved by adopting *Capacity Design Concept* (See IITK-BMTPC Earthquake Tip 9); the foundation system needs to be designed for loads higher than the ultimate flexural capacity of columns (Figure 4) or of structural walls.

Related IITK - BMTPC Earthquake Tip

Tip 9: How to make buildings ductile for good seismic performance?
Tip 31: Why do buildings sink into the ground during earthquakes?

Resource Material

Kramer, S.L., (1996), *Geotechnical Earthquake Engineering*, Prentice Hall, Inc., New Jersey, USA
Towhata, I., (2008), *Geotechnical Earthquake Engineering*, Springer-Verlag, Berlin

Authored by:

C.V.R. Murty

Indian Institute of Technology Jodhpur, India

Sponsored by:

Building Materials and Technology Promotion Council, New Delhi, India

This release is a property of IIT Kanpur and BMTPC. It may be reproduced without changing its contents with due acknowledgement. Suggestions or comments may be sent to: nicee@iitk.ac.in. To see all IITK-BMTPC Earthquake Tips, visit www.nicee.org or www.bmtpc.org.

Why do Buildings Sink into the Ground during Earthquakes?

What is Liquefaction of Soils?

A special situation arises during earthquake shaking in sandy (cohesionless) soils that are loose and saturated with water. Horizontal shaking of the earth at the bedrock level is transmitted upwards to overlying layer(s) of soil. Saturated loose cohesionless soils have voids between soil particles filled with water. During strong ground shaking, loose sand tends to densify; this tends to compress water, but because water is incompressible, it tends to escape out. Water cannot drain out quickly from the soil (Figure 1a), and therefore pore water pressure increases in soil; this reduces the effective stress between soil particles. At some stage the effective stress may become almost zero. In that situation, since soil strength depends on this effective stress, the soil may lose its shear strength completely and behave like a liquid; this phenomenon is called liquefaction. Buildings and structures rested on such soils can topple and sink into the ground (Figure 1b). Depending on soil properties and ground motion characteristics, the earthquake may impose shear stress demand in soil at some depth that exceeds shear strength capacity of soil; soil liquefies over this depth (Figure 2).

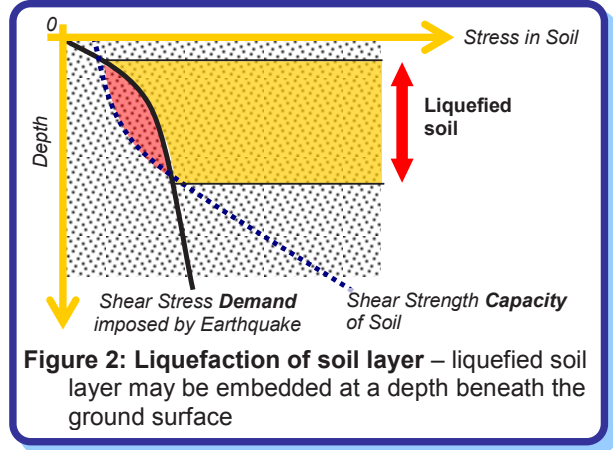

Figure 2: Liquefaction of soil layer – liquefied soil layer may be embedded at a depth beneath the ground surface

Physical Consequences of Liquefaction

During liquefaction, cohesionless soil-water mixture tends to behave like a liquid, and hence the ground tends to flatten out. For instance, embankments may collapse while the depth of ponds may reduce. This can have serious detrimental effects on structures.

(1) Sinking and uplifting of structures

As the cohesionless soil-water mixture liquefies, structures tend to settle or sink into the ground (Figure 3). In many cases, some parts of the building may sink more than the others, leading to tilting of the building. Similarly, buried structures tend to uplift and float up to the surface, because their overall density is lower than the liquefied soil.

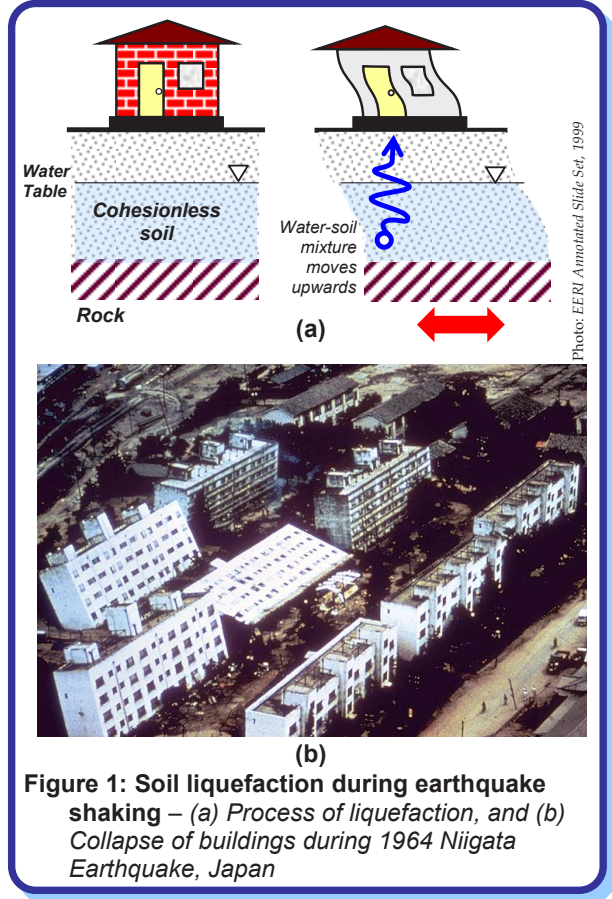

Figure 1: Soil liquefaction during earthquake shaking – (a) Process of liquefaction, and (b) Collapse of buildings during 1964 Niigata Earthquake, Japan

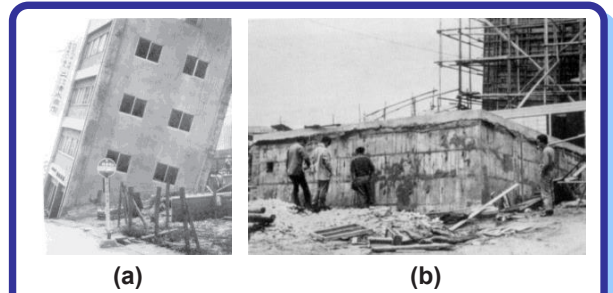

Figure 3: Sinking and uplift of structures – (a) Sinking of a building, and (b) uplift of sewage tank, during 1964 Niigata Earthquake, Japan

(2) Slope failures and lateral spreading

When soil at a lower level loses its strength to hold any load, the overlying soil layer may slide laterally, especially when slope is steep (>~5%) and the original soil is loose. This can cause landslides extending over hundreds of meters of motion of soil mass (Figure 4a). In both loose and dense soils, when the slope is gentle (<~3%), forward movement of a large soil mass can cause

Why do Buildings Sink into the Ground during Earthquakes?

disintegration of the large soil mass behind it. Therefore, structures may sink and destabilize, if supported by such soil (Figure 4b). Soil movement due to lateral spreading can exert significant stresses and damage in foundations and bridge abutments causing damages.

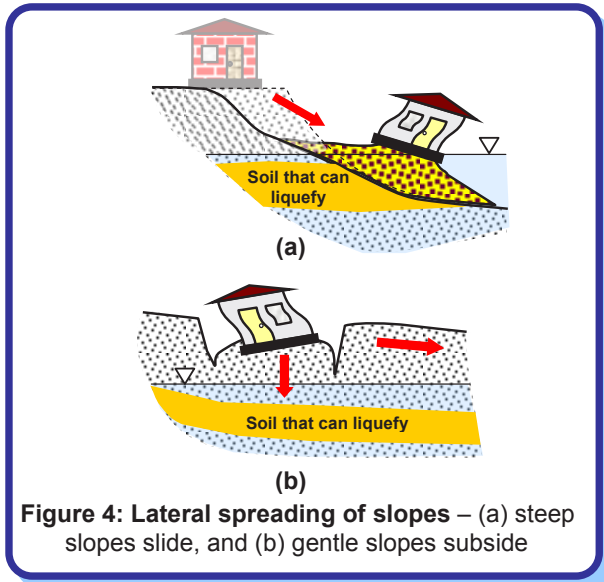

Figure 4: Lateral spreading of slopes – (a) steep slopes slide, and (b) gentle slopes subside

Parameters Influencing Liquefaction

Susceptibility of a site to liquefaction depends on following factors:

- (1) *Soil properties*: Uniformly-graded, fully-saturated cohesionless (sandy) soils are more prone to liquefaction than well-graded soils. Also, fine sands are more susceptible to liquefaction than coarse sands, gravelly soils, silts or clays. Sands with some clay content also can liquefy. Loose sands have much higher tendency to liquefy than dense sands.
- (2) *Earthquake shaking characteristics*: As shaking intensity increases, soil is subjected to higher stresses and strains, and is more susceptible to liquefaction. Also, strong shaking with longer duration causes a larger number of stress and strain cycles in soil; this increases chances for liquefaction.
- (3) *Geologic conditions*: Some geologic processes sort soils into uniform grain size and deposit them loosely, as in *Aeolian*, *Fluvial* and *Colluvial* deposits; such soils are candidates for liquefaction.

Measures to overcome Liquefaction

To overcome liquefaction one may:

- (a) *Increase liquefaction-resistance of soil*, e.g., densify loose deposits (by vibro-compaction, impact compaction and pressure grouting) or replace susceptible soil (by vibro-replacement) (Figure 5a);
- (b) *Reduce earthquake demand on soil*, e.g., release of pore water pressure by allowing drainage of water (by stone columns), or increase confinement by adding a surcharge (Figure 5b);
- (c) *Remove soil layers that can liquefy*, or use anchored piles as foundations going through liquefiable soil layers (Figure 5c).

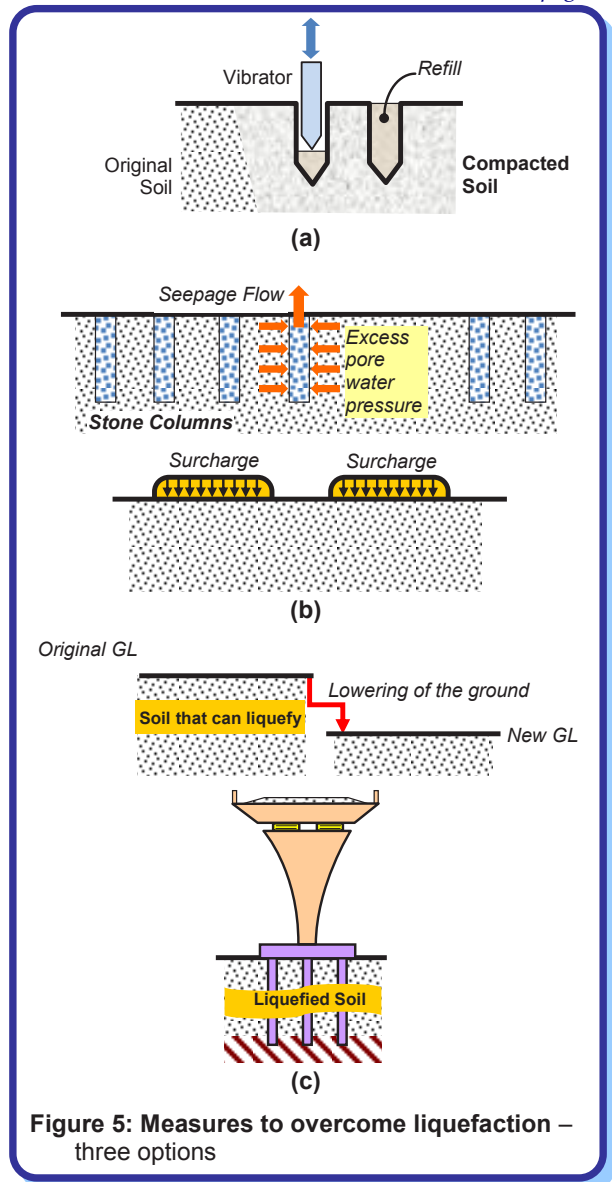

Figure 5: Measures to overcome liquefaction – three options

Related IITK - BMTPC Earthquake Tip

Tip 31: What is important in foundations of earthquake-resistant buildings?

Resource Material

Kramer, S.L., (1996), *Geotechnical Earthquake Engineering*, Prentice Hall, Inc., New Jersey, USA
 Towhata, L., (2008), *Geotechnical Earthquake Engineering*, Springer-Verlag, Berlin

Authored by:
 C.V.R.Murty
 Indian Institute of Technology Jodhpur, India
 Sponsored by:
 Building Materials and Technology Promotion Council, New Delhi, India

This release is a property of IIT Kanpur and BMTPC. It may be reproduced without changing its contents with due acknowledgement. Suggestions or comments may be sent to: nicee@iitk.ac.in. To see all IITK-BMTPC Earthquake Tips, visit www.nicee.org or www.bmtpc.org.

Why is Quality critical in Earthquake-Resistant Buildings?

Quality and Earthquake Safety

Quality is critical for ensuring safety of buildings during earthquakes. Appropriate measures are required to control quality in all activities related to development of *earthquake-resistant* buildings; if not, the weakest link will fail. While quality control is important also for buildings meant to resist effects other than those meant to resist earthquake shaking, there is a difference. Buildings meant to resist only *gravity loads* are designed to resist loads *much higher* (say about 2 to 3 times more) than the gravity loads that may arise during lifetime of the building. And hence, no damage occurs in buildings with minor structural deficiencies in individual members, because of availability of adequate margin in design. Thus, some error can be tolerated in design or workmanship without serious consequences or getting noticed.

On the other hand, buildings meant to *resist earthquake effects* are designed for lateral earthquake loads *much smaller* (up to about 10 times smaller) than what may be experienced during severe shaking, if the building were to sustain no damage during severe earthquake shaking. This is because earthquakes occur rarely. Hence, ordinary buildings are *expected* to undergo damage during strong shaking. Every structural element is expected to respond in a certain way, and is tested to its limit when strong shaking is experienced. Thus, deficiencies in structural elements can result in premature, unwanted or unwarranted failures. Because there is no margin, effects of poor quality are clearly noticed; the negative consequences of *poor quality* are most visible during severe shaking. Therefore, quality is *far more important* in buildings exposed to *earthquake effects* than in those exposed only to *other load effects* (e.g., gravity loads).

What is Quality Control?

Quality control means *adopting and ensuring* formal procedures and processes that are based on scientific principles and professionally agreed norms. The need to ensure quality arises at every step of the building development process. These steps include:

- (1) *Conceptualizing* structural configuration - *Architects* and *Structural Engineers* need to work together to adopt a good configuration;
- (2) *Designing* the structure - *Structural Engineers* need to take utmost care while performing required calculations as per sound *structural safety concepts* and *relevant design standards*;
- (3) *Preparing* structural drawings - *Structural Engineers* and *Draftsmen* need to comprehensively and accurately present structural design intent in well detailed drawings;

- (4) *Selecting* construction materials - *Contractors* need to take utmost care in selecting the *intended* construction materials, and adopting construction procedures as per standard specifications;
- (5) *Converting* structural drawings at site - *Competent Site Engineers* need to faithfully follow structural drawings to ensure that the design intent is actually realized in the building working with *Certified Artisans*, as per good construction practices laid down in standards and specifications; and
- (6) *Undertaking* post-construction activities - *Maintenance Engineers* need to embed long-term maintenance steps (like preventing leaks), thereby avoiding structural damage) in post-construction handling of structures, and preventing damage to buildings (especially to *critical structural members*).

What is Quality Assurance?

Rigorous, independent monitoring and correction need to be undertaken by competent *third party* professionals or professional agencies (other than those involved in the *Quality Control* effort) to ensure that the design intent is actually realized in buildings. This is referred to as *Quality Assurance*, and is required in each of the activities mentioned above.

How Quality can be Ensured

Owners and developers have the responsibility of ensuring that their buildings are *functional, safe* and *durable*, in addition to being *economical* and *aesthetic*. Quality must be ensured by all stakeholders involved in the building delivery process, including architects, structural engineers, draughtsman, contractors, site engineers, artisans (e.g., bar benders, carpenters and masons), and maintenance engineers. Each activity needs to adhere to a pre-specified procedure laid down in design codes and standards. There is no single activity that is more important than the others, which alone determines the quality of the building being built. For instance, just designing the building for a higher seismic lateral force to compensate for poor quality in construction will not ensure a safe building. Even if *one* of the key stakeholders fails to deliver quality, overall earthquake safety of building may be jeopardised.

Building owners *need to seek* professional services that comply with: (1) proper understanding and estimation of earthquake *hazard* at the site, (2) rigorous design, compliance with prevalent standards, specifications and bye-laws, (3) independent design review (peer review), (4) procurement of intended quality materials, (5) careful construction of the building, (6) independent construction audit, and (7) approved occupancy and use of buildings. Any

Why is Quality critical in Earthquake-Resistant Buildings?

shortfall in understanding or implementing (to the fullest) any of these aspects leads to compromising safety of life and property in the building.

Services of *competent* professional architects and engineers are essential to incorporate the above aspects in buildings; these professionals need to have past experience of having successfully provided such services. Building owners are faced with many challenges in *earthquake-resistant design and construction*. These include:

- (1) *Identifying competent architects and design engineers:* There are many standards and specifications for *earthquake-resistant design and construction* of buildings, which architects and design engineers need to be conversant with. The mandatory curricula in architecture and engineering colleges often do not ensure that the required background is provided to graduates. Thus, it is unlikely that *all* architects and engineers practicing today understand earthquake behavior of structures, and the design techniques required to incorporate earthquake-resistance in them. So, building owners face a challenge related to selecting *competent* professionals to undertake earthquake-resistant design of their buildings. Governments need to establish robust systems for identifying competence-based *licensing of engineers*, who could assist building owners;
- (2) *Complying with Building Codes & Municipal Controls:* Local governments require architects and design engineers to ensure safety of buildings through faithful compliance with various *building codes* and *municipal bye-laws*. This cannot happen only on the basis of voluntary effort by professionals – it is the responsibility of municipal authorities to enforce compliance. But, a severe shortage of suitable adequately trained personnel in municipal offices can be a bottleneck for ensuring compliance on part of local governments. Alternate strategies are required to build a robust system for *Enforcement of Earthquake Safety*, e.g., independent peer review by consulting engineers of good standing; and
- (3) *Undertaking hazard estimation studies:* Seismic hazard assessment must consider many uncertainties. For ordinary buildings, it is best to adopt seismic design codes of the country. But, for projects of importance, site-specific studies are required, for which owners will require services of *competent earthquake geologists, seismologists, earthquake geotechnical engineers and seismic structural engineers*.

Faithfully converting construction drawings of buildings into actual structures is critical for ensuring earthquake safety of buildings. *Competent* contractors must be appointed by building owners to implement formal construction strategies and construct earthquake-resistant buildings. Quality control needs to be exercised at all stages of construction by *Contractors*. But, independent agencies need to test quality of all construction materials before accepting

them. Similarly, independent competent engineers employed for site-supervision need to examine that work being is done as intended. These independent engineers employed for site inspection need to have requisite *competence*. Therefore, *Competence-Based Licensing of Construction Engineers and Certification of Artisans* are essential.

Professional Ethics

Earthquake-resistant design and construction is possible only with high ethical standards employed by all personnel involved. A project can be successfully executed only by avoiding all three types of errors – *Error of Intention, Error of Concept* and *Error of Execution*. *Error of intention* is really an issue of *ethics*, while errors of *concept* and *execution* are of *competence*. For instance, a professional accepting an assignment beyond one's competence is indulging in unethical practice. Similarly, if a professional realizes that one is unable to follow correct procedures and still proceeds with the project, it is an unethical practice. And finally, an engineer not following code provisions to reduce structural cost, indulges in unethical practice.

In civil constructions, society takes performance of a structure for granted. For instance, one drives over a bridge unconsciously, assuming it is safe. Hence, it is critically important to ensure and enforce highest levels of ethical standards in the practice of engineering. It is not possible to legislate virtues. But, the situation can be alleviated to some extent by putting in place systems and procedures, e.g., (a) *competence-based licensing*, wherein license to practice is given only after establishing that the person has at least a minimum set of skills required to practice design and construction, which may be revoked in case of a malpractice, and (b) a robust regulatory legal system, with a rigorous enforcement protocol and implementation mechanism that allows for swift penalties and punishments to erring individuals. Such systems have been effective in many countries, and must be established in countries like India.

Related IITK - BMTPC Earthquake Tip

Tip 9: How do make buildings ductile for good seismic performance?

Resource Material

Bellet,D., (2006), *Fundamental Concepts and Principles for Assuring Acceptable Performance of Schools and the Education System*, Chapter 10, *Keeping Schools Safe in Earthquakes*, Overseas Press India Private Limited, New Delhi

Authored by:

C.V.R.Murty

Indian Institute of Technology Jodhpur, India

Sponsored by:

Building Materials and Technology Promotion Council, New Delhi, India

This release is a property of IIT Kanpur and BMTPC. It may be reproduced without changing its contents with due acknowledgement. Suggestions or comments may be sent to: nicee@iitk.ac.in. To see all IITK-BMTPC Earthquake Tips, visit www.nicee.org or www.bmtpc.org.

For more information, please write to:

The Executive Director
Building Materials & Technology Promotion Council
Ministry of Housing & Urban Poverty Alleviation, Govt. of India
Core-5A, First Floor, India Habitat Centre,
Lodhi Road, New Delhi 110 003
Tel: 91-11-2463 6705, 2463 8096; Fax: 91-11-2464 2849
E-mail: bmtpc@del2.vsnl.net.in
Website: www.bmtpc.org

The Coordinator
National Information Centre of Earthquake Engineering
Indian Institute of Technology Kanpur
Kanpur 208 016
Tel: 0512 259 7866
Fax: 0512 259 7866; 259 7395
E-mail: nicee@iitk.ac.in
Website: www.nicee.org

