



# Illustrated Owners and Parts Manual



Made In  
The USA



## **ROKON International Inc.**

50 Railroad Avenue  
Rochester, NH 03839  
Tel: 603 335-3200  
Fax: 603 335-4400  
e-mail: [parts@rokon.com](mailto:parts@rokon.com)  
web site: [www.rokon.com](http://www.rokon.com)



Welcome to the growing group of ROKON owners. All operators must read and familiarize themselves with this owners manual and the safety information.

The ROKON Warranty Statement is enclosed with this manual. For it to be validated, the complete ROKON Utility Vehicle Registration Card must be signed and returned to ROKON within 10 days of the date of purchase.

We congratulate you on your decision to purchase a ROKON Utility Vehicle. By following the procedures and suggestions outlined in this manual, you will be rewarded with many hours of reliable, gratifying performance that others have come to expect from ROKON Utility Vehicles.

## **BEFORE YOU OPERATE YOUR NEW ROKON, THE FOLLOWING IMPORTANT POINTS MUST BE OBSERVED.**

- 1.** Children under 16 should not operate a ROKON.
- 2.** Carefully read and follow the instructions in the safety section of this manual.
- 3.** Carefully read and follow the setup procedure on the yellow card attached to your ROKON (See yellow card instructions, also on page 56 of this manual).
- 4.** Follow the Pre-Operation Checklist.

## **TABLE OF CONTENTS**

<b>SECTION:</b>	<b>Page</b>
<b>1. Safety Information</b>	3-4
<b>2. Description and Machine Identification</b>	5
<b>3. Control Functions</b>	6-7
<b>4. Pre-Operation Checks</b>	8
<b>5. Operating Your Rokon</b>	9-10
<b>6. Periodic Maintenance and Adjustment</b>	11-15
<b>7. Repair Procedures</b>	16-21
<b>8. Torque and other specification charts</b>	22
<b>9. Limited Warranty</b>	23
<b>10. Illustrated Parts Manual</b>	24-53

## Section 1

# Safety Information

Always wear an approved motorcycle helmet that fits properly, eye protection (goggles or face shield), gloves, sturdy boots, long sleeve shirt, jacket and pants while operating a ROKON.

Never consume alcohol or drugs before or while operating a ROKON.

The ROKON is a go slow vehicle. Never operate at speeds too fast for your skills or the conditions. Always operate at a speed that is appropriate for the terrain, visibility and operating conditions and your experience.

**DANGER-SERIOUS INJURY MAY RESULT!** Never attempt wheelies, jumps or other stunts of any kind while operating a ROKON.

Always keep both hands on the handlebars during operation.

Always go slow and be extra careful when operating on unfamiliar terrain. Always be alert to changing terrain conditions when operating a ROKON.

Never operate on excessively rough, slippery or loose terrain until you have learned and practiced the skills necessary to control the ROKON on such terrain.

Never operate on hills too steep for the ROKON or for your abilities. Never exceed a 60% grade (or 31 degrees). Practice on smaller hills before attempting larger hills.

Always follow proper procedures for climbing hills as described in this manual. Check the terrain carefully before you start up any hill. Never climb hills with excessively slippery or loose surfaces. Shift your weight forward when on an incline.

Always follow proper procedures for going down hills and for braking on hills as described in this manual on pages 9 and 10. Check the terrain carefully before you start down any hill. Shift your weight rearward. Never go down a hill at high speed. Shift into 1st range and keep the torque converter engaged for engine braking as described on page 9 in this manual. Use the rear brake only in down hill corners. Apply the rear brake before the front brake when going straight down.

Always maintain proper tire pressure.

Never modify your ROKON. Use only ROKON parts. Follow instructions, and properly install ROKON parts.

# Safety Information



**WARNING:**  
Potential bodily injury.  
Never operate a ROKON without the chain guards and side covers in place and securely attached with all fasteners properly tightened.



Never exceed the stated load capacity. Cargo should be properly distributed and securely attached. Reduce speed and follow instructions in this manual for carrying cargo or pulling a trailer. Be careful to allow greater distances for braking when carrying cargo or operating with a trailer.

Read your engine manual completely and follow all safety instructions.



**WARNING:**  
Potential Hazard- Improper Handling of Gasoline can catch fire and you could be burned.

Always turn off the engine when refueling. Do not refuel right after the engine has been running and is still very hot. Do not spill gasoline on the engine or exhaust pipe/muffler when refueling. Never refuel while smoking, or while in the vicinity of sparks, open flames or other sources of ignition such as the pilot lights of water heaters and clothes dryers. When transporting the machine in another vehicle be sure that it is kept upright and that the fuel cock is in the "OFF" position (see page 6 of manual). Otherwise, fuel may leak out of the carburetor and flood the engine.

Gasoline is poisonous and can cause injuries. If you should swallow some gasoline or inhale a lot of gasoline vapor, or get some gasoline in your eyes, see your doctor immediately. If gasoline spills on your skin, wash with soap and water. If gasoline spills on your clothes, change your clothes.



**WARNING**  
Potential Hazard- Starting or running the engine in a closed area.

Exhaust fumes are poisonous and may cause loss of consciousness and death within a short time. Always operate your machine in an area with adequate ventilation

## Section 2

# Description and Machine identification

Record the Vehicle Identification number and Engine Number in the spaces below to facilitate ordering spare parts or for reference if the vehicle is stolen

VIN \_\_\_\_\_

Engine Number \_\_\_\_\_



The Engine number is on the front of the engine facing the front wheel.



The Vehicle identification number is on the center frame tube beneath the driver seat.



## Section 3

# Control Functions

The Shut Off Switch is black in color and is located on the left hand side of the handlebar. Pressing the “kill” switch will shut off the engine. This is a safety feature and will allow the operator to immediately shut off the engine in an emergency.



The Fuel Petcock located on the right hand side under the fuel tank shuts off fuel flow to the engine. The down position is for fuel flow. The up position shuts fuel off. Shut the fuel off when storing or transporting your ROKON.



Throttle. The engine is accelerated by twisting the throttle grip on the right hand side of the handlebar counterclockwise. The throttle grip is spring loaded and will automatically close the throttle and slow the engine when released.



Brakes. The ROKON Utility Vehicle is equipped with separate front and rear disc brakes. The left brake lever is for the rear brake. The right brake lever is for the front brake.



The Choke is used to start a cold engine and should be in the rearward position to choke. It is located on the right hand side of the engine. As soon as the engine starts, the choke should gradually be moved forward as the engine warms up. It should be left fully forward for regular operation.



Recoil Starter. Firmly grasp the handle and pull slightly until engagement can be felt. Then pull forcefully, being careful not to pull the rope all the way out. Return the starter rope gently.



Rider Seat Suspension. The seat suspension spring can be adjusted to suit the rider's weight and riding conditions. Adjust the spring per load as follows: To increase the spring preload, turn the adjuster clockwise. To decrease the spring preload, turn the adjuster counterclockwise.



Transmission: The three range transmission is a ratio selector and when coupled with the automatic torque converter, gives the vehicle extremely broad capabilities, from steep climbing to normal transporting. The torque converter provides a large overlap of speed and torque between gears. This makes frequent gear changes unnecessary. Therefore, the transmission has not been designed to shift in motion. **STOP THE VEHICLE BEFORE SHIFTING.** Shift only at low idle or when the engine is off. Feel the gears into engagement, rocking the bike, if necessary, to synchronize the gears. The shift pattern is from inside out: 3-N-2-N-Low.



Automatic Torque Converter: The torque converter is designed especially for ROKON and provides smooth automatic clutching and ratio changing in response to throttle control and terrain requirements. The front drive pulley tends to shift into high as engine speed is increased. The rear driven pulley follows this speed change. If torque requirements increase, the cam in the torque-sensing rear pulley overrides the front pulley and forces a down shift without a loss of engine revs and power.



**WARNING:**  
Potential Hazard- Starting the engine in gear. could cause the Rokon to move forward unexpectedly. **PUT THE TRANSMISSION IN NEUTRAL BEFORE STARTING THE ENGINE.** Stand on the left hand side, put the front Brake on with 2 fingers of your left hand, throttle closed, reach over the ROKON and pull the starter handle.



## Section 4

# Pre-operation Checks

***Before using this machine, check the following points.***

Front and Rear Brake. Check brake action. Check pucks to see that they are not over worn. There should be visible brake material on both sides of the brake disc. See Section 6.

Fuel Tank. Check fuel level. Fill as necessary. Use super unleaded for altitudes above 10,000 ft.

Engine Oil. The engine holds .6 qt. of SAE10W30/40 motor oil. Fill to the dipstick "full" line.

Miter Box and Transmission. They are filled at the factory and need not be checked at the start. The miter box should have 2.5 oz. of EP 80W90 gear lube oil. The transmission takes 6 oz. of EP 80W90 gear lube oil. The transmission has a fill to plug near the bottom of the transmission( shown on page 46). There is no fill level for the miter box. Over filling of either the miter box or transmission will result in leakage.

Throttle. Check for proper throttle cable operation. Look for smooth response to twist action.

Wheels and Tires. Check Tire pressure, wear and damage.

Fittings and Fasteners. Check all fittings and fasteners.

Drive Chains. Check chains for tension and lubrication. Adjust tension for 1/2" - 3/4" deflection at mid point.

Engine Manual. Read your engine manual completely and follow all instructions.

FAILURE TO INSPECT YOUR ROKON BEFORE OPERATION  
INCREASES THE POSSIBILITY OF AN ACCIDENT OR EQUIPMENT  
DAMAGE. ALWAYS INSPECT YOUR ROKON EACH TIME YOU USE IT  
TO MAKE SURE IT IS IN SAFE OPERATING CONDITION.

## Section 5

# Operating Your ROKON

When starting your ROKON, place the range selector in neutral. Stand on left hand side, put the front brake on with two fingers of your left hand, throttle closed, reach over the Rokon and pull the starter handle. For a cold start put the choke on. Once the engine turns over, set the choke off. Pull on the starter again and the vehicle will start. Engage the three-range selector in the desired gear range. Put the ball of the foot, rather than the instep on the footrest. Accelerate and ride. Use braking as necessary. Pre-plan your route before attempting to negotiate difficult terrain. Lean into the hill when climbing switch backs. Descend steep slopes at slow speed in low range. Apply rear brake pressure before front brake application.



### WARNING

Potential Hazard: Failure to use extra care when operating a ROKON on unfamiliar terrain. Go slow and be extra careful on unfamiliar terrain. You can come upon hidden rocks, bumps, or holes, without enough time to react. Always be alert to changing terrain conditions when operating a ROKON.

Traversing a sloping surface requires you to properly position your weight to maintain proper balance. As you travel across or up a slope, lean your body in the uphill direction. It may be necessary to correct the steering when riding on loose surfaces by pointing the front wheel slightly uphill. When riding on slopes be sure not to make sharp turns either up or down hill, which could cause a ROKON to turn over and cause the rider injury.



When riding downhill, shift your weight as far to the rear and uphill side as possible. Use low gear and engage the throttle slightly to allow the engine compression to provide braking. Whenever possible ride straight downhill. Turn into corners with the rear brake only, so as not to slide the front wheel and lose steering control.





The ROKON can be used to cross slow moving shallow water of up to a maximum of 24 inches in depth. Before entering the water, choose your path carefully. Enter where there is no sharp drop off, and avoid rocks or other obstacles which may be slippery or upset the ROKON. Drive slowly and carefully. Never change your course in the middle of a stream or you will find that slippery rocks and currents might throw you out of balance.



If the water is over 24" in depth, always float your machine across (hollow wheels only). Keep the air intake out of the water to avoid flooding the engine compartment.

Riding over rough terrain should be done with caution. Look out for obstacles which could cause damage to the ROKON or lead to an upset or an accident. Avoid jumping the ROKON as loss of control and damage may result.



The real secret to riding perfection is throttle control. Remember that gradual acceleration will take you anywhere you desire with the proper gear selection. Your throttle is designed to retract upon release of the hand as a safety measure for the rider. Always grasp your throttle with ease, and never with full force.

The ROKON is designed with individual disc brakes on the front and rear gear boxes. The right hand front brake will stop both wheels through the gear train. When braking with the front brake, the machine should be in a "straight away" position. Hard braking, with a turned front wheel, can cause a loss of steering which can result in loss of control. The left hand rear brake should be used more often for going down steep slopes.



# Periodic Maintenance and Adjustment

**Routine care of your ROKON vehicle is easily done and is important for rider safety and vehicle longevity.**

1. Inspect all fasteners for tightness.
2. The drive chains require adjustment at intervals, depending on the mileage and the care which the operator has given the chains. Initial wear must be taken up by adjustment after the first few hours of use. Total deflection should be 1/2" to 3/4" when measured midway between the two sprockets of the most loose position. To adjust the chains, loosen the axle bolts and the adjusting bolt lock nuts, and turn the adjusting bolts equally in or out as required to give the chain the proper setting. After adjusting the chain, rotate the wheel and check to make sure the chain is aligned properly. Periodically, the chains should be removed from the machine and cleaned in solvent and re-lubricated. They should be lubricated with one of the chain lubricants on the market which can be applied to the chain in a liquid form and will penetrate to the inner parts of the rollers.
3. Clean the air filter based on use. See Engine Manual.
4. Use normal repair procedures for tires and tubes. Re-seat the tire beads with 40 PSI , then deflate to the 3 -5 PSI operating pressure.
5. The Miter Box and Transmission should not require service other than checking the oil level or replacing oil seals. The Miter Box should be removed and oil changed yearly. The Miter Box is assembled with special tooling to determine the correct tooth engagement and backlash. It is not advisable to attempt to dismantle the unit, unless necessary. The transmission should be drained and refilled on the same yearly schedule. There is a drain plug on the bottom of the transmission, a fill level plug partway up, and a fill plug on the top. The Miter box takes 2.5 fluid oz. of EP 80W90 gear lube oil. The transmission takes 6 fluid oz. of EP 80W90 gear lube oil.
6. Check Belt for wear. Belts last at least a year and generally average 4-5 years.
7. Check the throttle for full return and feel.

**Storing your ROKON**

1. Close the gasoline shut-off valve, this will prevent fuel leakage when transporting or storing your ROKON. This is a key item when transporting your ROKON for example on the wheel free carrier.
2. Start the engine and allow it to run until it stops from lack of fuel. This will use up all the fuel in the carburetor and prevent the formation of deposits due to evaporation of fuel.
3. Disconnect fuel line and permit all fuel to drain from the gasoline tank. Replace the fuel line.

**Trouble Shooting**

SYMPTOM	PROBABLE CAUSE
<p><b>1. Twist grip sticks.</b></p>	<p>Twist grip end rubbing on handlebar.                      Deposit buildup under twist grip.                      Worn or broken twist grip or throttle cable.                      Throttle linkage improperly adjusted.                      Moisture under grip freezing in cold temp.</p>
<p><b>2. Chains loosen frequently.</b></p>	<p>Improperly seated chain adjustment bolts.                      Loose axle bolts.                      Improper chain alignment.                      Chains need lubrication.                      Twisted or distorted chains.</p>
<p><b>3. Excessive end play in wheel.</b></p>	<p>Loose axle bolts.                      Improper axle or wheel spacer thickness.                      Defective wheel bearings.                      Distorted bearing retainer housing in wheel.</p>
<p><b>4. Chain scoring tire sidewall.</b></p>	<p>Improper chain alignment.                      Improper axle spacer thickness.                      Defective wheel bearings.</p>

**Trouble Shooting**

SYMPTOM	PROBABLE CAUSE
<p><b>5. Noisy driveline.</b></p>	<p>Driveline improperly seated.                      Worn or broken override spring.                      Worn, broken or loose carrier bearing or bearing retainer.                      Worn bosses leading into override spring.                      Worn universal joint.</p>
<p><b>6. Noisy front miter box.</b></p>	<p>Low oil level.                      Loose gearbox mounting bolts.                      Worn or broken bevel gears.                      Worn shaft bearings.                      Improper gear mesh.</p>
<p><b>7. Rear wheel won't drive.</b></p>	<p>Wheel chain off sprocket.                      Sheared roll pin on drive sprocket</p>
<p><b>8. Front wheel won't drive.</b></p>	<p>Wheel chain off sprockets.                      Sheared roll pin in sprocket.                      Broken override spring on driveline.                      Worn bosses leading to override spring.                      Defective transmission.</p>
<p><b>9. Engine stalls when machine stops.</b></p>	<p>Debris in carburetor.                      Improperly adjusted throttle linkage.                      Ice in system.                      Idle set too low.</p>
<p><b>10. Valve core disappears within wheel. (only tubed tires)</b></p>	<p>Tire pressure too low.                      Tube not secured by stem kit.</p>

## Trouble Shooting Engine

SYMPTOM	PROBABLE CAUSE
<b>1. Engine will not start.</b>	No fuel in tank or shut-off valve closed. Spark plug not firing. Fuel not being delivered to combustion chamber. Engine flooded. Too much fuel in combustion chamber. Improper spark plug gap. Plugged fuel filter.
<b>2. Engine hard to start.</b>	Water or dirt in fuel or stale fuel mixture. Weak ignition spark. Plugged air filter. Engine over or under choked. Gasket or seal leaks. Spark plug fouled.
<b>3. Engine starts but will not continue to run.</b>	Insufficient fuel supply. Fuel line clogged. Vent on filler cap plugged. Dirty carburetor. Air leak in fuel system. Defective or fouled spark plug. Idle screw not adjusted properly.
<b>4. Engine misses.</b>	Dirt in fuel system. Spark plug fouled or defective. Faulty magneto or improper ignition coil air gap setting. Idle screw not adjusted properly.
<b>5. Engine lacks power.</b>	Air cleaner clogged. Incorrect spark plug – gap too wide or too narrow. Incorrect air gap on ignition coil. Worn or stuck piston rings or leaky head gasket. Ice in system. Hi altitude running. (use hi altitude jet)

**Trouble Shooting Engine**

SYMPTOM	PROBABLE CAUSE
<p><b>6. Engine overheats.</b></p>	<p>Engine overloaded.                      Oil too low in crankcase.                      Incorrect spark plug.                      Ignition timing over-advanced.                      Scored piston or cylinder wall.                      Lean Mixture.                      Dirty air filter / blocked air intake.</p>
<p><b>7. Engine noisy or knocking.</b></p>	<p>Loose flywheel.                      Worn bearings.                      Broken or loose parts inside engine.                      Lack of oil in crankcase.</p>
<p><b>8. Engine stalls under load.</b></p>	<p>Fuel line restricted or tank vent closed.                      Engine overloaded.</p>
<p><b>9. Poor acceleration.</b></p>	<p>Air cleaner clogged.                      Ignition timing over-advanced or retarded.                      Leaking gaskets.                      Air gap too wide.                      Exhaust restriction.                      Low compression.</p>
<p><b>10. Poor high speed performance.</b></p>	<p>Low compression.                      Pre-ignition.                      Spark plug or air gap improper.                      Belt worn.                      Brakes dragging.</p>



## Care and Adjustment of ROKON Brakes

**General:**

Rokon all wheel drive vehicles have individual front and rear disc brakes. They are cable operated by hand levers on the handlebars. The left lever controls the rear brakes and, in the forward direction, stops the rear wheel. The overrunning clutch in the driveline allows the front wheel to continue rotating. The right lever operates the front brake and stops both wheels. The discs are high mounted to keep them out of water and mud. Though small, they are powerful due to the torque multiplication of the sprocket ratio.

**Refer to the Rokon Parts Manual for help with part names and assembly sequence.**

**Maintenance:**

The brakes operate with little or no maintenance, but work more smoothly and last longer if kept clean and lubricated.

Be sure that all parts including the moveable pucks move freely and that the levers return fully.

Be sure that all fasteners are secure. Use self locking nuts, locktite or cotter pins on all fasteners.

Lubricate shaft and keys, push pins and cam, as needed, with a drop of motor oil.

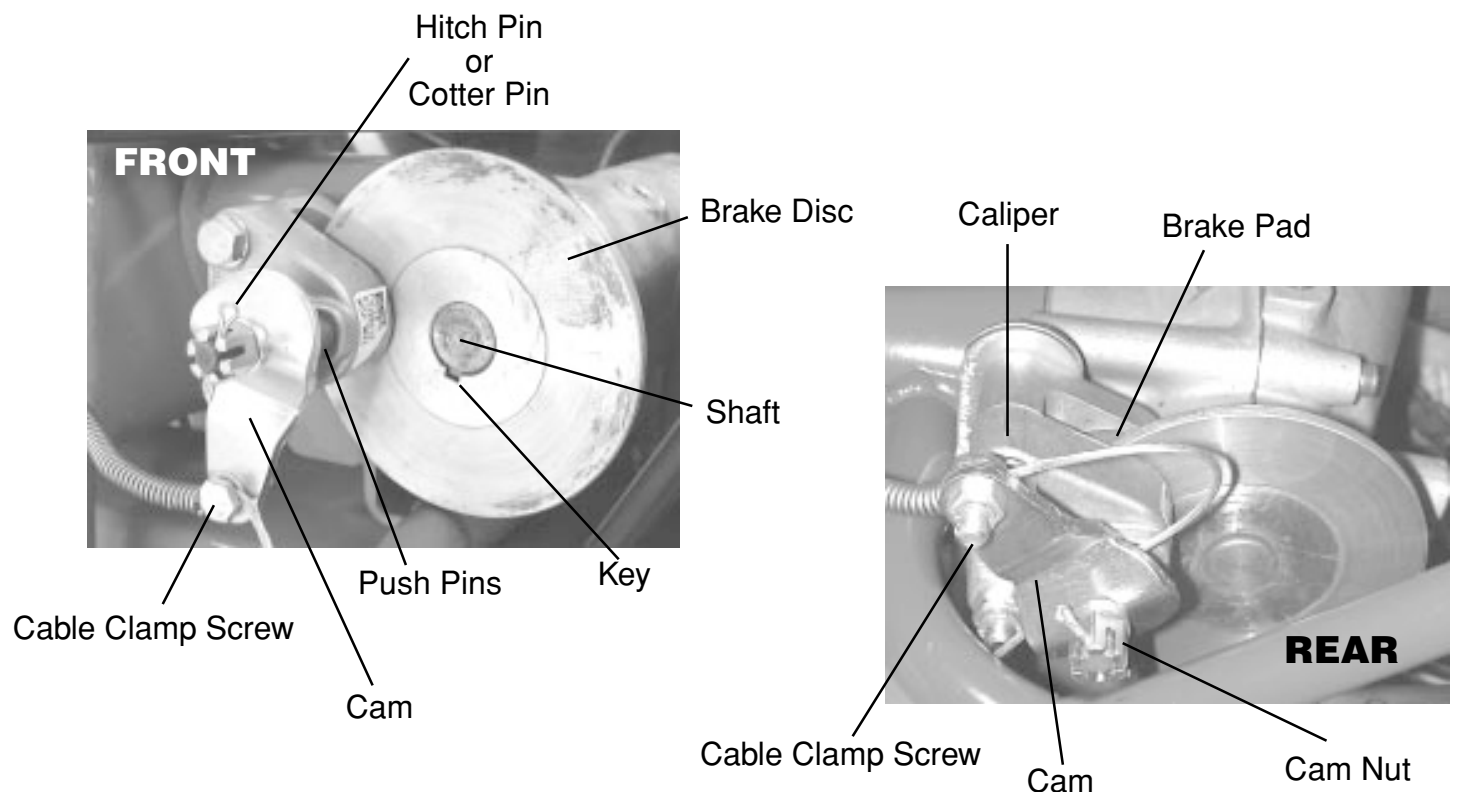

**Maintenance:**

Cables are plastic lined and do not require lubrication though it is OK to do so.

Be aware that a drop of water in a cable may freeze and prevent braking. Use boots and lubricants to prevent this. Test before riding off in freezing weather.

Replace pucks when they are down to 1/4 inch thick. The moveable puck is loose, but the stationary puck is secured to the caliper with a small slotted head screw. Locktite this screw.

**Adjustment:**

New Pucks.

After installing new pucks, reassemble the calipers and securely tighten the two 5/16" screws. Remove the cotter pin and finger tighten the cam nut so that the cam push pins are at the bottom of the cam. This is the starting point. Now at the hand lever, set the cable housing adjusting screw out about 1/4 inch and lock it up by finger tightening the lock nut. At the cam, loosen the cable clamp screw and pull the cable through snugly and clamp it up. Now loosen the cam nut so you can ride with a few fingers holding the brake lever, but with enough lever stroke left for locking up the brakes if need be. Check for good braking and snappy return.

In The Field.

A quick adjustment for brake wear can be made without tools at the handlebar by loosening its locknut and extending the cable housing adjusting screw. Retighten the locknut. It is best not to go too far with his adjustment as the overextended adjustment screw may then get hit and broken. When you can, return the cable housing adjusting screw to its normal 1/4 inch extension and take up pad wear at the caliper by pulling the hitch or cotter pin, tightening the cam retaining nut and replacing the pin.



Brake Lever

Lock Nut

Cable Housing  
Adjusting Screw

Cable Housing

**I. TRANSMISSION AND DRIVELINE REMOVAL PROCEDURE****Section 1, Procedure for transmission removal:**

1. Elevate and secure the bike firmly to a non-moving stand. Bike should be elevated so that the rear wheel is not touching the ground.
2. Remove all fiberglass side covers from the bike.
3. Shut fuel valve. Disconnect fuel line and plug, if necessary. Remove fuel tank.
4. Remove front seat. This is accomplished by removing the two attaching bolts on each side of the front seat bracket and the bottom shock absorber attaching bolt. The whole assembly can be removed and put aside.
5. If transmission and driveline need to be removed, the rear wheel and rear fender will need to be taken off the bike. If only the transmission needs to be removed, the rear wheel may stay intact. *See Section 2 for Drive Line Removal.*
6. Remove the rear drive chain by locating the master link and separating it from the chain.
7. Remove the rear driveline roll pin. (If transmission and driveline are to be taken out as one unit, leave roll pin attached for ease of disassembly.) This is done by inserting a pin punch into the roll pin access hole (located under the front seat, which was removed), and driving the pin straight downward. Note: Rotate rear wheel until hole lines up.
8. Remove drive belt.
9. Remove driven clutch. Loosen the three Allen screws behind the clutch. Note: Driven clutch may be frozen on to the shaft. A small piece of wood and a mallet from behind the clutch should ease removal. Care must be taken, not to damage clutch. Use pry bars if necessary.
10. Remove muffler header pipe. (Loosen two 12mm nuts. Pull muffler off engine seat. Pull muffler out of sleeve).
11. Remove rear brake caliper assembly. Take caution not to undo the brake line from the spring assembly. Disconnect cotter pin and back off brake tension. Remove brake caliper assembly and brake bracket as a complete unit. (Remove the two 1/2 " bolts under the brake disc.). Slide Brake Disc off shaft. Take note the way the caliper and brake disc came off for reassembly.

12. Remove all four transmission attaching bolts, three on the frame mount, and one next to the upper cross shaft. (Two should already be removed from the brake bracket as described in step 11).

**At this point:** Transmission can be removed, by moving left to right to loosen it from the Driveline clutch, sliding back into fender well, and carefully turning sideways and pulling upward. Note: If the transmission can be shifted into 3rd gear, it will ease removal, by having the shift ball closer to the transmission.

Reverse disassembly procedure for assembling.

**Note:** Replace worn parts as needed. (ie.: roll pins, Worn nuts or bolts, drive belt, etc.) Use thread lock compound on transmission bolts upon reassembly.

## Section 2, Procedure for Transmission and Driveline Removal:

1. Follow steps 1-5 in Section 1.
2. Remove in order: rear wheel, tail section of muffler, and rear fender.
3. Remove the two carrier bearing bolts, which are located under the fuel tank.
4. Remove front chain guard cover, front drive chain, and headlight. Note: Ground wire for the headlight must be routed behind front miter box assembly.
5. Remove front brake caliper assembly. Note: Take caution not to undo the brake line from the spring assembly. Disconnect cotter pin and relieve brake tension. Remove two 1/2" bolts that secure the assembly to the bracket. Swing out of the way. Remove brake disc.
6. Remove front miter box assembly. (This is done by removing the two 1/2" bolts from behind the miter box assembly.) Pull miter box assembly straight out of bore, with universal joint attached. Set aside.
7. Remove transmission assembly and drive line as one unit (Ease disassembly by making sure the transmission is shifted into the highest gear. Shift ball closest to the transmission.) Pull the assembly straight out of the bore.
8. Reverse procedure for reassembly.

**II. Front Miter Box and Universal Joint Removal Procedure**

1. Remove front chain guard and front chain. Use a 1/2-inch wrench or socket to remove chain guard. Then find master link and loosen chain. Remove master link. Take chain off.
2. Remove headlight. Using 1/2 inch wrench loosen and remove nut that attaches light to fender. Unplug power lead & disconnect ground that is attached at miter box mounting bolt. Set aside.
3. Remove brake caliper and disc. Using 1/2 inch wrench & socket remove both bolts that hold caliper in place. Remove caliper & replace bolt and nuts to keep pucks in place and let caliper hang off the side of the bike & remove brake disc.
4. Remove miter box. At this point you should have removed the bolt on the left side of the bike (this attached ground for headlight). Remove the left bolt and pull miter box straight out (the universal joint will come with the miter box).
5. Replace broken or worn parts as needed including universal joint, gears or seals.
6. After repairs are made and with the universal joint in place, slide miter box (gently) into place. You will feel it hit the drive shaft. Slide your index & middle fingers of your right hand between the fork and where the universal joint is located. Pinch the universal joint with these two fingers. Slide the brake disc into place and use this to spin miter box. As you are spinning miter box you should feel it locate itself on the woodruff key as it catches back into place. To make sure the universal joint is located properly, lock the rear brake and spin disc counter clockwise. If the disc doesn't spin, it has been installed properly. If the miter box does spin, remove and check to see if woodruff key is in place. If it has slipped out, you can retrieve the key by tilting the bike up on its nose and it will fall out. Replace the key by means of long needle nose pliers or your finger and repeat the procedure.
7. When you have the miter box installed properly, reverse procedure 1-5.

## III. FRONT DRIVE LINE SYSTEMS CHECK

1. Elevate bike so wheels are not touching the ground.
2. Apply front brake.
3. Rotate rear tire in forward direction.
4. While rotating rear tire (in forward direction), check front universal joint for rotation. If the universal joint is spinning, check roll pin that attaches front drive sprocket. If roll pin is not damaged, then the internal miter box roll pin is sheared. If the universal joint is not spinning, look into rear inspection holes, under the seat, to see if slip clutch is turning.
5. If slip clutch turns then the roll pin attaching the drive shaft to the slip clutch is sheared. If slip clutch is not spinning, check to see if roll pin attaching slip clutch to the transmission is sheared. If roll pin is not sheared, then an internal transmission roll pin is sheared.
6. If miter box is damaged, it must be removed. Miter box must be disassembled and repaired as needed.
7. If this roll pin connecting the drive shaft to the slip clutch is sheared, it is recommended that the drive shaft be replaced. Line up pin hole and replace.
8. If the internal transmission damage is suspected, transmission must be removed and repaired as necessary. Contact ROKON for transmission repair.

## Section 8

# Torque and other Specification Charts

Torque and Threadlocking Specifications For Fasteners On Rokon 2WD Vehicles

Fastener Size	Location	Thread locking	Torque	
			In. lbs.	Ft. lbs.
10-32	Foot Rest Tube	Lock Washer	25	2
1/4			84	7
5/16	Transmission	Loctite 242 + Lock Washer	180	15
	Brake Mounting	Self Locking Nuts		
	Wheel Bearings	Loctite 242		
	Foot Rest	Self Locking Nuts		
3/8	Engine Mounting		360	30
1/2			720	60
3/4	Steering	Loctite 242	2400	200
M5			25	2
M6			84	7
M8			180	15
M10			360	30

### Miscellaneous Specs

Tire Pressure 3 - 5 PSI

*See Engine Manual for engine details.*

## ROKON WARRANTY SYSTEM

ROKON International Inc. warranties to the original purchaser, new ROKON Utility vehicles to be free of defects that are the result of faulty workmanship or material, for a period of one year from the date of purchase for new year model ROKONs only. In the case of competition machines, no warranty is expressed or implied. The entire risk to the quality and performance of competition machines is with the buyer.

Warranty will be honored through any authorized ROKON dealer or the factory. To validate warranty, Purchaser must: Complete and return Warranty registration Card to ROKON International, Inc. within ten (10) days of purchase.

Notify ROKON of any and all defects made within ten (10) days of malfunction and make machine immediately available for inspection at a place to be determined by ROKON.

Have warranty service performed by an authorized Rokon agent as directed by ROKON.

Warranty will not cover:

- Parts replaced as a result of normal wear. (ie.: spark plugs, tires, tubes , and so forth)
- Parts subject to misuse, neglect, or modification.
- Parts damaged as a result of accident or collision.
- Machines used for rental and/or lease.
- Machines used in competitive events.
- Machine abuse.

ROKON International Inc.'s liability shall be limited to that set forth herein, and no other claims for consequential damage or injury to person or property will be admissible. All other conditions and warranties, statutory or otherwise, and whether expressed or implied, including, but not limited to, implied warranties of merchantability or fitness for a particular use, are hereby excluded. This implied warranty exclusion is not applicable in states having laws to the contrary.





# Illustrated Parts Manual

## Index of Illustrations

<b>Page</b>	<b>Nomenclature</b>
25	Brakes
26	Chain Parts
27	Decals
28	Electrical
29	Engine Honda
30 & 31	Engine Kohler
32 & 33	Frame
34	Front fork
35	Cargo Rack Assembly
36	Fuel Tank Assembly
37	Muffler
38 & 39	Handlebar Assembly
40	Pullstarter
41	Front Seat
42	Rear Seat
43	Torque Converter Drive Pulley
44	Torque Converter Driven Pulley
45	Tow Bar
46	Transmission Complete
47	Transmission with Attachments
48 & 49	Transmission in Sequence
50	Miter Box
51	Transmission to Miter Box
52	Aluminum Wheels
53	Steel Wheels
54	Wiring Diagram

# Brake

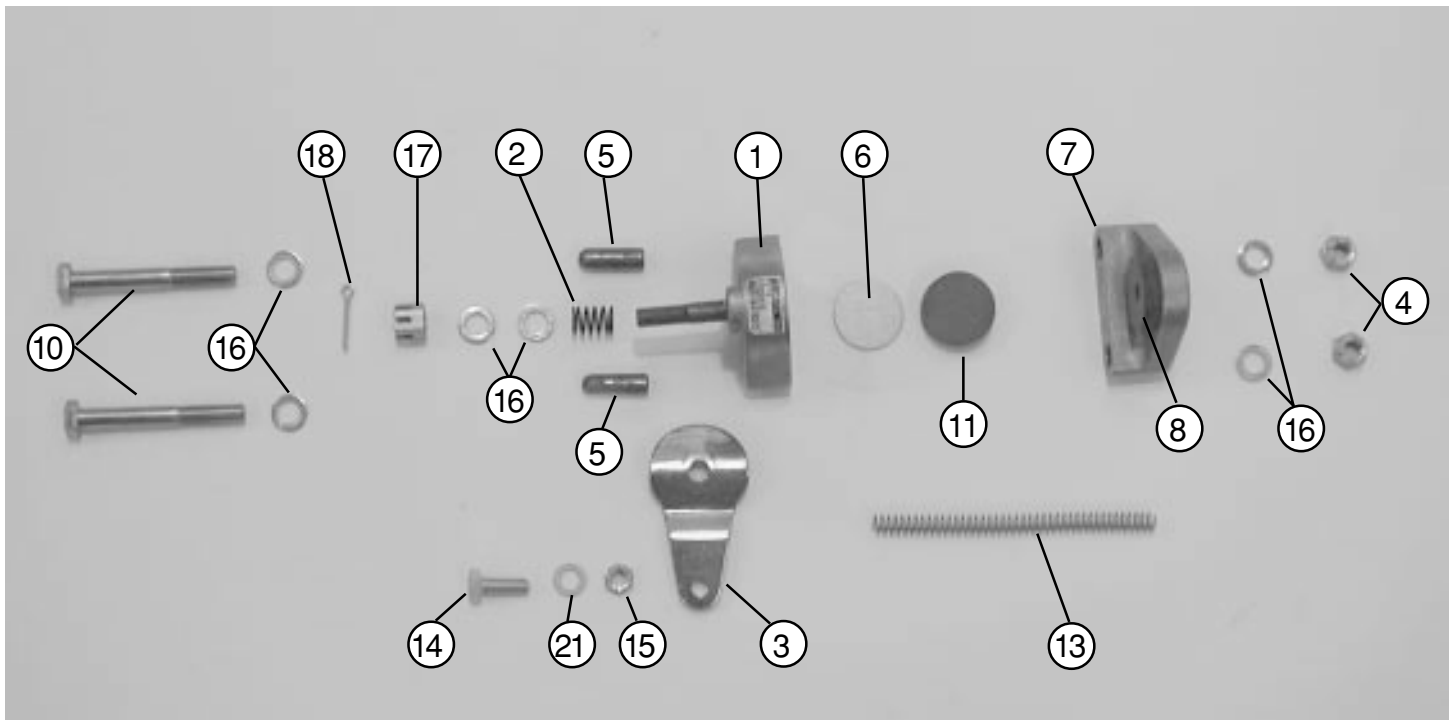

Item	Part Number	Name	Description	Qty
1	108023	Live Side Housing		1
2	108024	Compression Spring		1
3	108025	Lever Arm		1
4	108026	Locking Nut		2
5	108027	Actuating Pin		2
6	108028	Back Plate		1
7	108029	Dead Side Housing		1
8	108030	Dead Side Puck		1
9	108031	Flat Head Screw		1
10	108032	Hex Head Bolt		2
11	108033	Live Side Puck		1
12	108002	Caliper Assembly		1
13	100788	Brake Spring		1
14	100509	Brake HH Bolt	1/4-28 x 3/4 Hole for Cable	1
15	100169	Nut		1
16	100202	Washer	5/16	4
17	108982	Castle Nut		1
18	101673	Cotter Pin		1
19	100481	Brake Puck Set	Includes 108030 & 108033	1
20	108002	Brake Caliper Assy.	Includes everything except 13	1
21	100254	Washer	1/4	1

# Chain

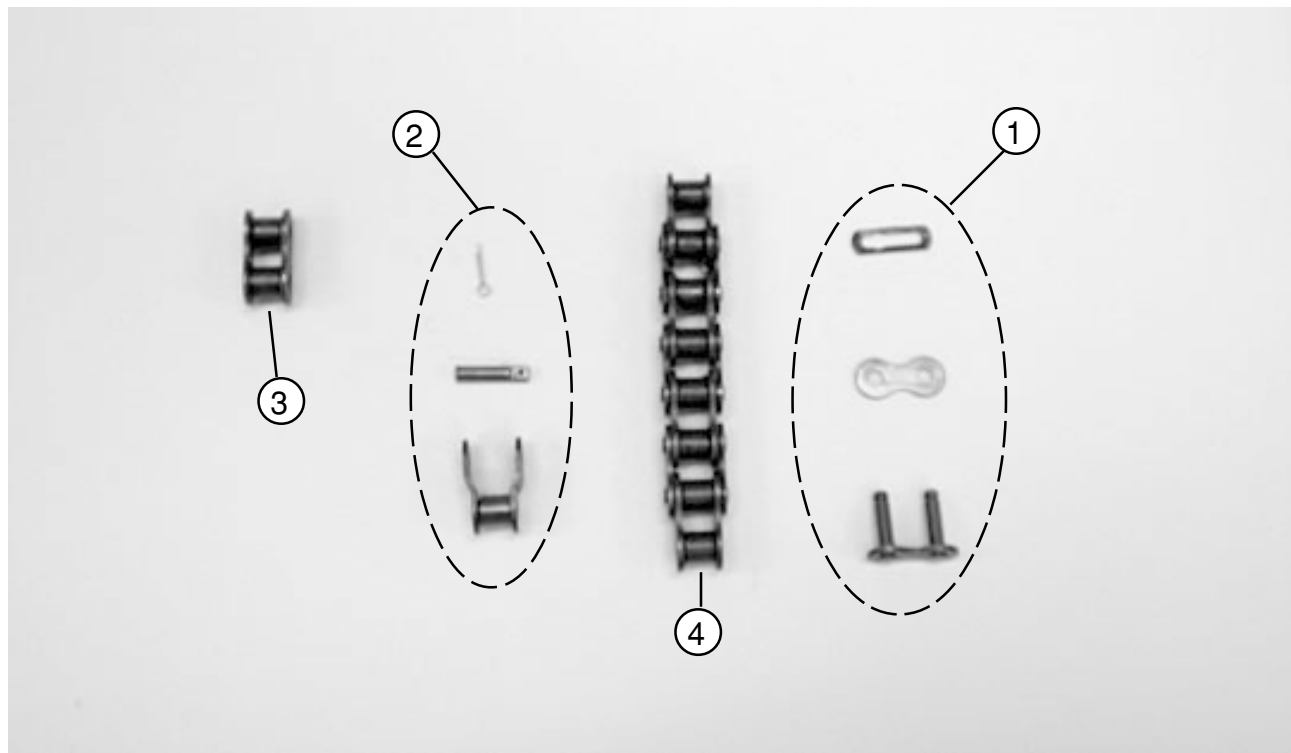

Item	Part Number	Name	Description	Qty
1	100356	Master Link		2
2	100355	Offset Link	as needed	
3	100354	Full Link	as needed	
4	108984	Chain Length	as needed	
5	101568	Front Chain 107P	not shown	1
6	101570	Rear Chain 117P	not shown	1

# Decals

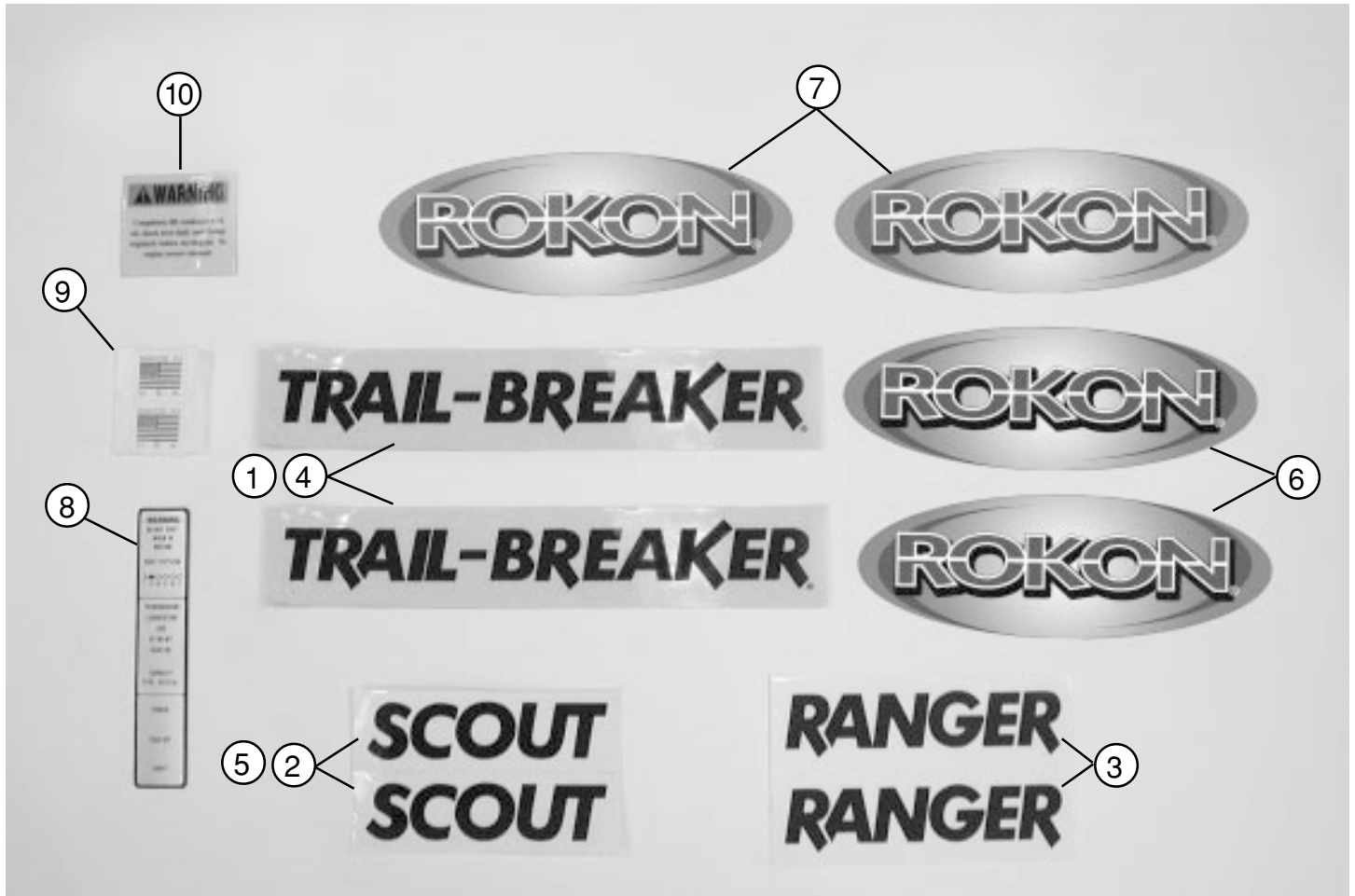

Item	Part Number	Name	Qty
1	108039	Decal "Trail-Breaker" in Black	2
2	101595	Decal "Scout" in Black	2
3	108041	Decal "Ranger" in Black	2
4	108040	Decal "Trail-Breaker" in Red	2
5	108043	Decal "Scout" in Red	2
6	108990	Decal "Rokon" Oval in Red	2
7	108991	Decal "Rokon" Oval in Brown	2
8	101626	Decal "Shift Instructions"	1
9	108057	Decal Made in USA	2
10	108988	Decal Oil Warning	1
11	108972	Decal Handlebar "Rokon"	1

# Electrical

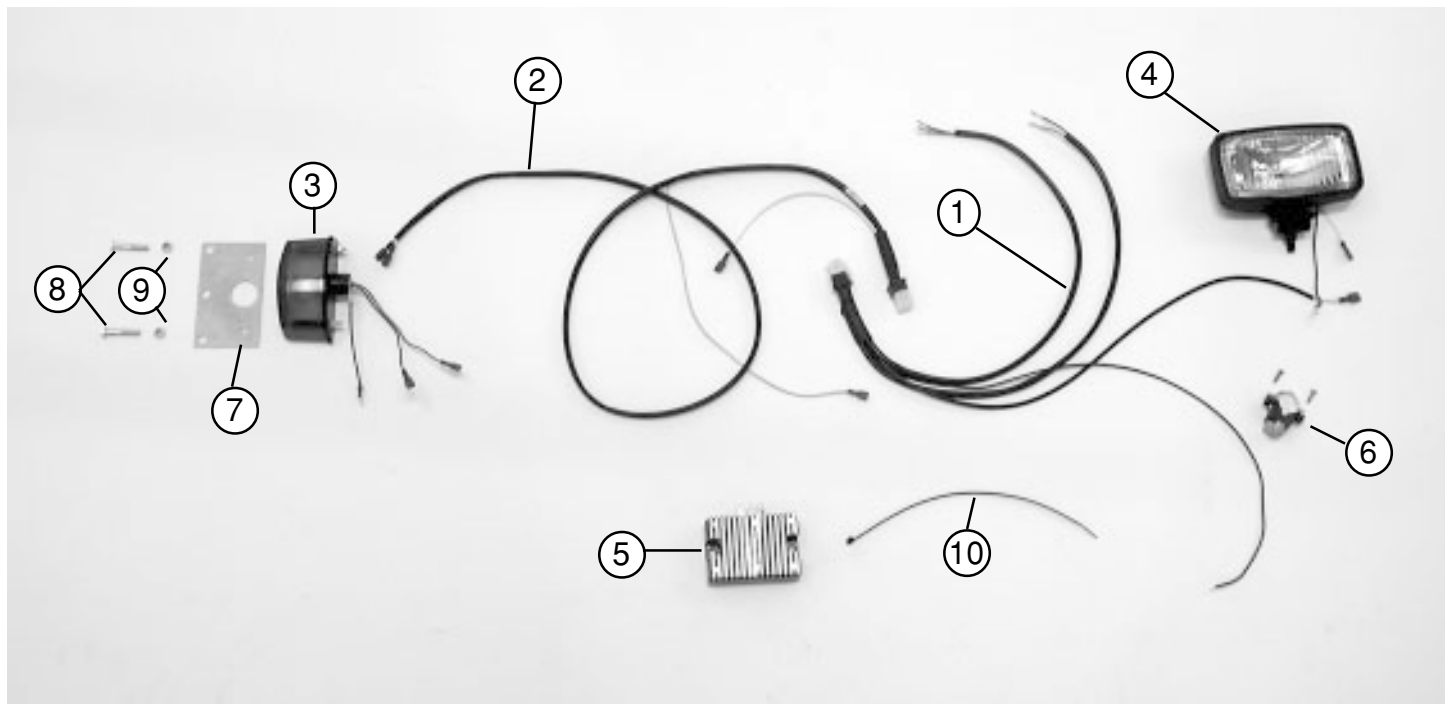

Item	Part Number	Name	Description	Qty
1	108177	Wiring Harness Front		1
2	108178	Wiring Harness Rear		1
3	104315	Rear Tail Light		1
4	104313	Headlight		1
5	108126	Voltage Regulator		1
6	100190	Kill Switch Assembly		1
7	101135	Brake Light Mounting Plate		1
8	100170	Bolt	HH Bolt 1/4-28 x 1 1/2	2
9	100169	Nut	Lock Nut 1/4-28	2
10	100448	Cable Tie (Long)	As Necessary	2
11	100449	Cable Tie (Short)	As Necessary	6

# Honda Engine

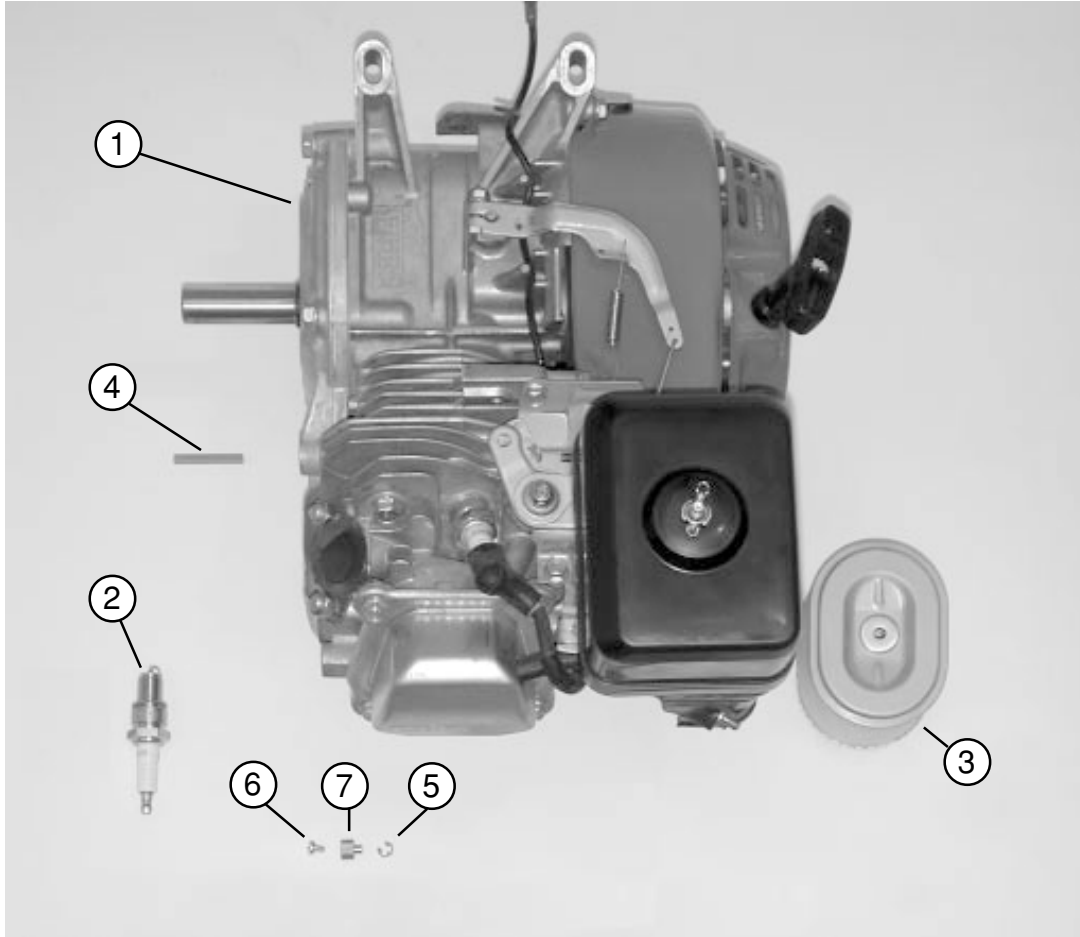

Item	Part Number	Name	Description	Qty
1	HONGX160	Honda Engine	GX160	1
2	100369H	Spark Plug		1
3	HON5247408	Air Filter		1
4	101548H	Crank Key		1
5	108253	E Clip		1
6	108254	Screw	M4 Size, 6 mm length, .7mm pitch	1
7	108256	Cable Holder		1

# Kohler Engine

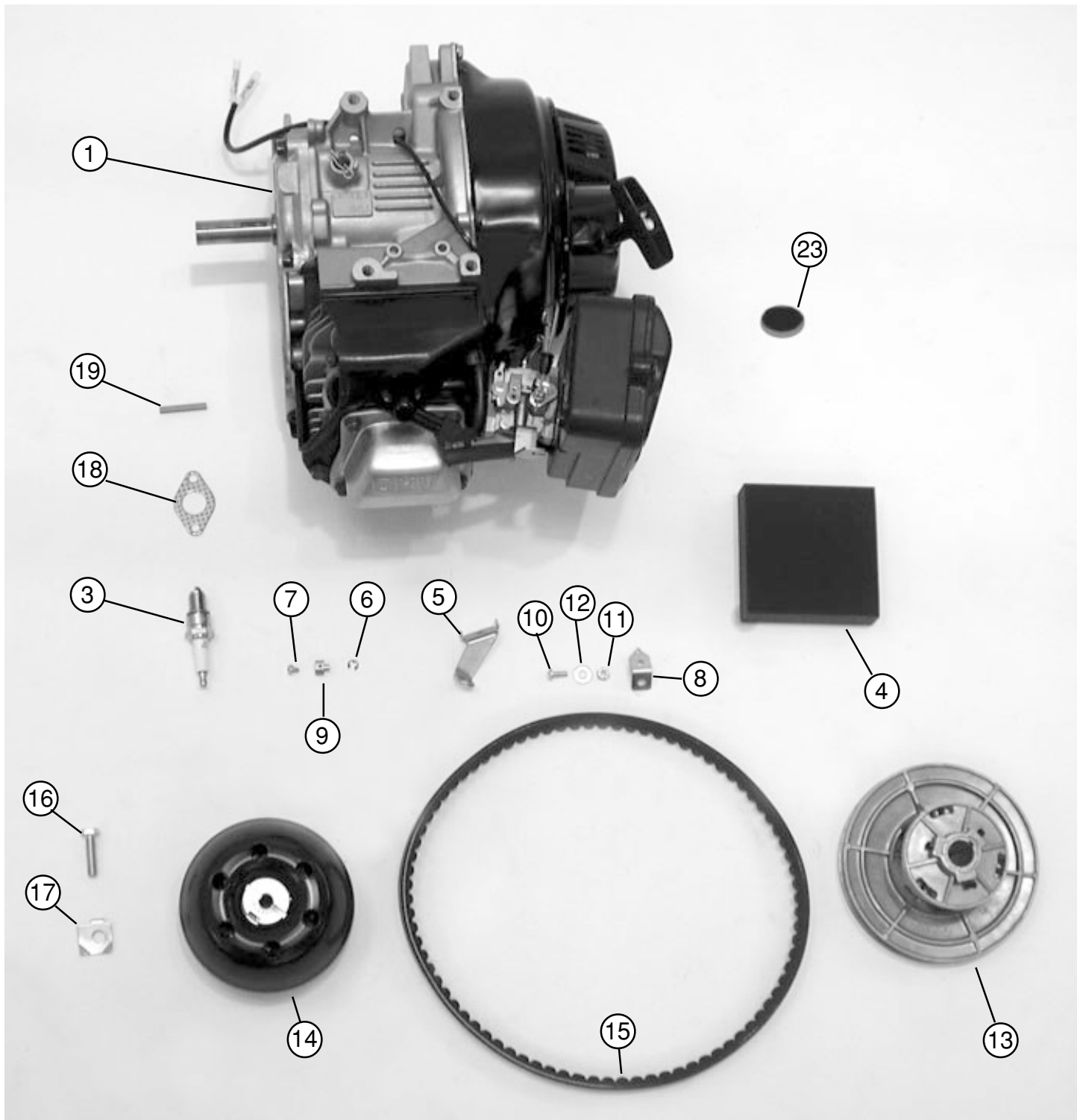

# Kohler Engine

Item	Part Number	Name	Description	Qty
1	KOH PA911512	6.6 Hp Kohler Command PS		1
2	KOH PA911513	6.6 Hp Kohler Command ES	not shown	1
3	100369K	Spark Plug		1
4	KOH6308306-S	Air Filter		1
5	108235	Throttle Bracket		1
6	108253	E Clip		1
7	108254	Screw	M4 Size, 6 mm length .7mm pitch	1
8	108246	Choke Bracket		1
9	108256	Cable Holder		1
10	100034	Screw	Pan Head Screw 10-32 x 1/2	1
11	100037	Nut	Hex Nut Self Lock 10-32	1
12	100165	Washer	Washer #10 flat	1
13	100884	Rear Driven Pulley		1
14	100885	Torque Converter Drive Pulley		1
15	108137	Drive Belt		1
16	108123	Clutch Bolt		1
17	108983	Locking Clip		1
18	KOH6304121-S	Exhaust Gasket		1
19	KOH6334005-S	Key Crank		1
20	KOH6385304-S	Carburetor Complete	not shown separately	
21	KOH6375704-S	Carburetor Repair Kit	not shown	
22	KOH Air Box Assy	Kohler Air Box Assembly	not shown separately	
23	108968	Nylon Snap In Plug		1



# Frame



# Frame

Item	Part Number	Name	Description	Qty
1	105066	Frame		1
2	108243	Rear Fender Kohler		1
3	108994	Fairing LHS		1
4	108995	Fairing RHS Front		1
5	108996	Fairing RHS Rear		1
6	100386	Kickstand		1
7	100223	Kickstand Spring		1
8	100285	Clevis Pin	5/16" x 1 3/8"	1
9	100290	Cotter Pin	1/8" x 3/4"	1
10	108272	Foot Rest RHS Cleated		1
11	108271	Foot Rest LHS Cleated		1
12	100343	Passenger Foot Rest (Set of 2)		1
13	101572	Rubber Chain Guard		1
14	101629	Stud for Fairing		6
15	101630	Receptacle for Fairing		6
16	100126	Bolt	1/4-20 x 5/8 HH Bolt	2
17	100255	Washer		2
18	100573	Wheel Adjuster Bolt		2
19	100036	Nut	3/8-24 Jam	2
20	108087	Rear Fender Honda	not shown	1
21	100273	Bolt	Pan Head Screw 10-32 x 1/4	6
22	100275	Lock Washer	Lock Washer #10	6
23	100034	Screw	Pan Head Screw 10-32 x 1/2	2
24	100037	Nut	Hex Nut Self Lock 10-32	2
25	108123	Bolt	HHCS gr 5 5/16-24X 1 1/2 ZN	2
26	100551	Nut	Locknut 5/16-24 Hex	2

# Front Fork

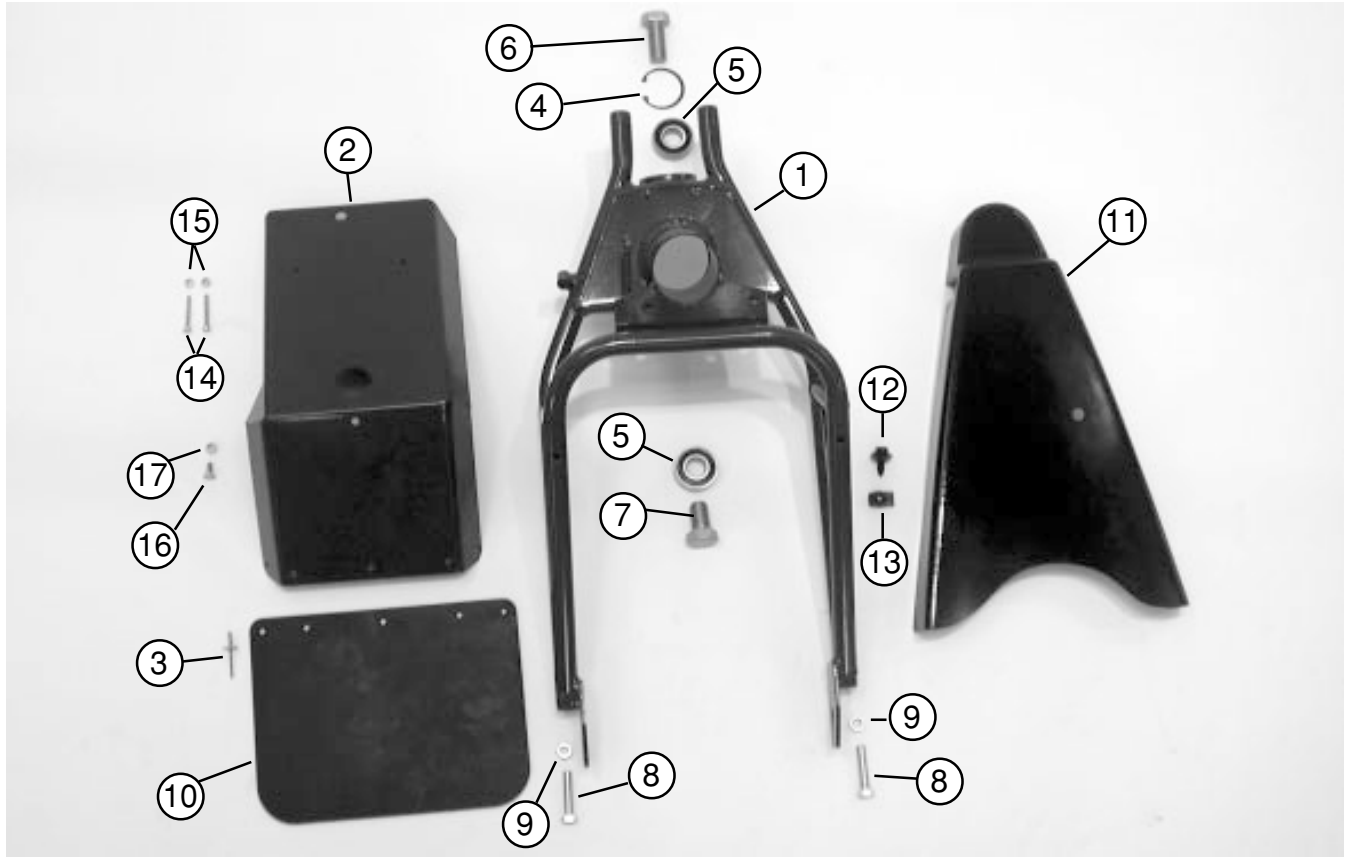

Item	Part Number	Name	Description	Qty
1	105064	Front Fork Weldment		1
2	100453	Front Fender		1
3	100935	Pop Rivet		5
4	103136	Snap Ring		1
5	100772	Bearing	Sealed	2
6	107026	Upper Fork Bolt	Use Locktite 242	1
7	107025	Lower Fork Bolt	Use Locktite 242	1
8	100573	Wheel Adjuster Bolt	HH Bolt 3/8-24 x 1 3/4 Fully Threaded	2
9	100036	Nut	Hex Nut Jam 3/8-24	2
10	100427	Front Mud Flap		1
11	108106	Front Chain Guard		1
12	101629	Stud		1
13	101630	Receptacle		1
14	100035	Screw	Pan Head Screw 10-32 x 1 1/2	2
15	100037	Nut	Hex Nut Self Lock 10-32	2
16	100167	Bolt	1/4-28 x 1/2 HH Bolt	1
17	100169	NutLock	Nut 1/4-28	1

# Front Cargo Rack



Item	Part Number	Name	Description	Qty
1	100423	Front Cargo Rack		1
2	100167	Screw	HH 1/4-20 x 1/2	2
3	100281	Washer	1/4" Lock Washer	2
4	100170	Screw	HH 1/4-28 x 1 1/2	2
5	100255	Washer		2
6	100169	Nut	1/4 x 28 Locking	2
7	100892	Front Cargo Rack Kit	Includes all items above	

# Fuel Tank



Item	Part Number	Name	Description	Qty
1	103120-GR	Fuel Tank Forest Green		1
2	102843	Fuel Cap		1
3	102766	Fuel Filter		1
4	101295	Shut off Valve		1
5	100122	Fuel Line		3
6	102594	O Ring		1
7	102593	Nut	9/16"-18	1
8	102590	Fuel Tank Fitting		1
9	101969	Rubber Fuel Tank Washer		1
10	101970	Bolt	HH 1/2-20 x 3/4	1
11	102589	Flat Washer		1
12	103120-RED	Fuel Tank Red	not shown	
13	103120-OD	Fuel Tank Olive Drab	not shown	
14	103120-BLK	Fuel Tank Black	not shown	

# Muffler

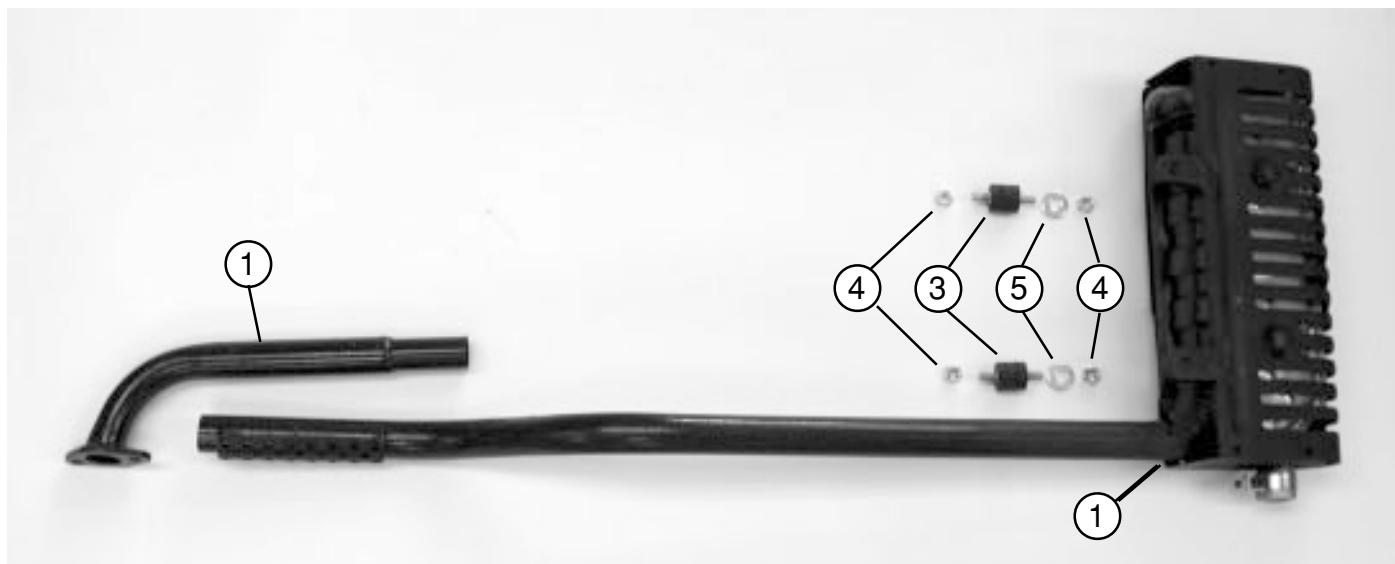

Item	Part Number	Name	Description	Qty
1	108236	Muffler Kohler		1
2	108150	Muffler Honda	not shown	1
3	108998	Sandwich Mount		2
4	108997	Nut	1/4-20 Jam Nut Nylock	4
5	100255	Washer		2
6	KOH6331402-S	Muffler Guard	not shown	

# Handle Bar

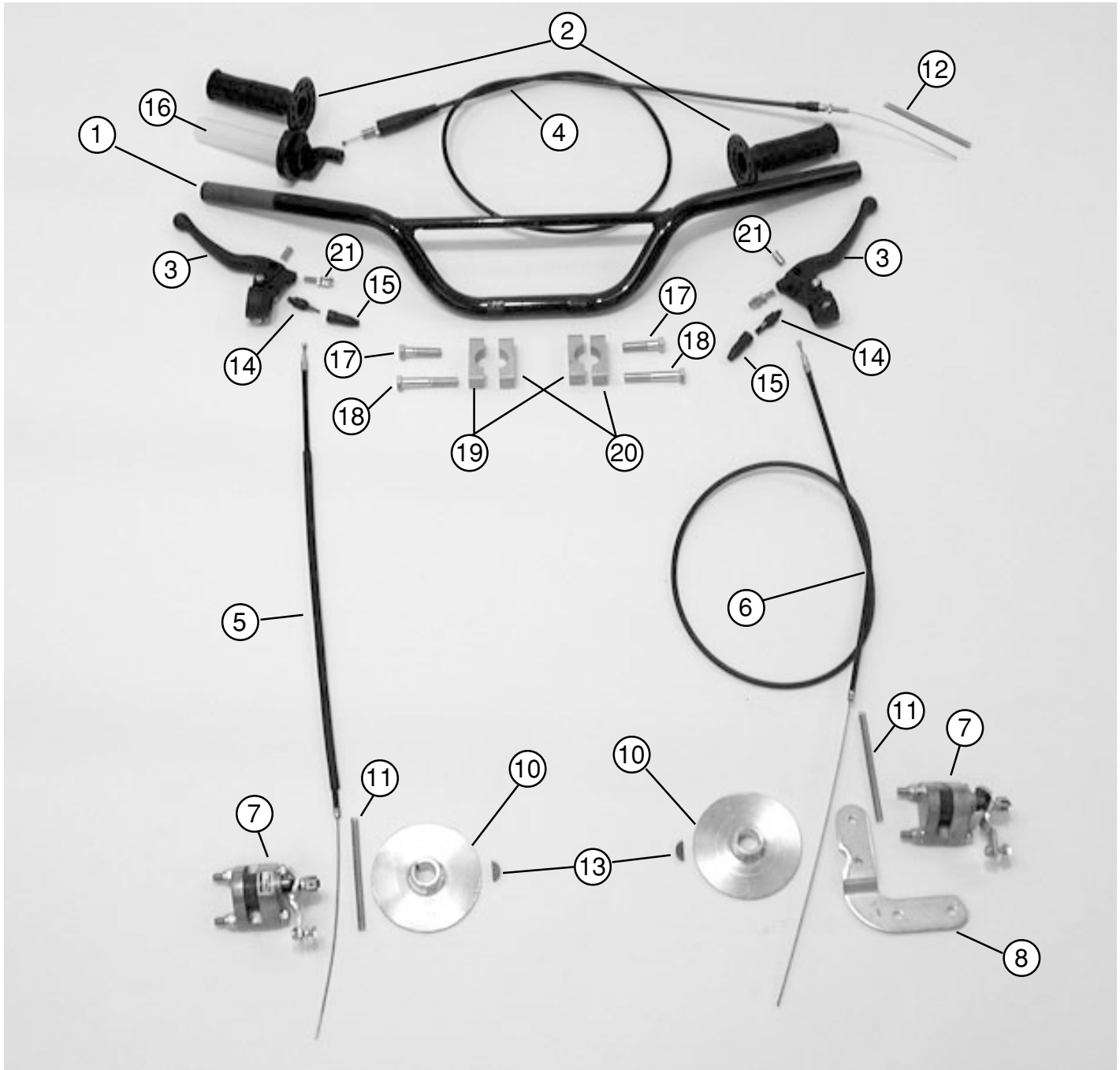

# Handle Bar

Item	Part Number	Name	Description	Qty
1	100466	Handlebar		1
2	100071	Grip Set		1
3	100820	Brake Lever		2
4	107036	Throttle Cable		1
5	100015B	Front Brake Cable		1
6	100014HB	Rear Brake Cable		1
7	108002	Brake Caliper		2
8	108234	Rear Brake Bracket (Kohler Only)		1
9	108001	Rear Brake Bracket (Honda Only)	not shown	1
10	100610	Brake Disc		2
11	100788	Brake Spring		2
12	100559	Throttle Spring		1
13	100043	Woodruff Key	#9	2
14	104309	Brake Switch		2
15	107033	Boot		2
16	103113	Twist Grip		1
17	108173	Handlebar Clamp Bolt Short	3/8-24 x 1 1/2	2
18	108174	Handlebar Clamp Bolt Long	3/8-24 x 2 1/4	2
19	108115	Handlebar Clamp Upper		2
20	108116	Handlebar Clamp Lower		2
21	103116	Cable Adjuster		2



# Pullstarter

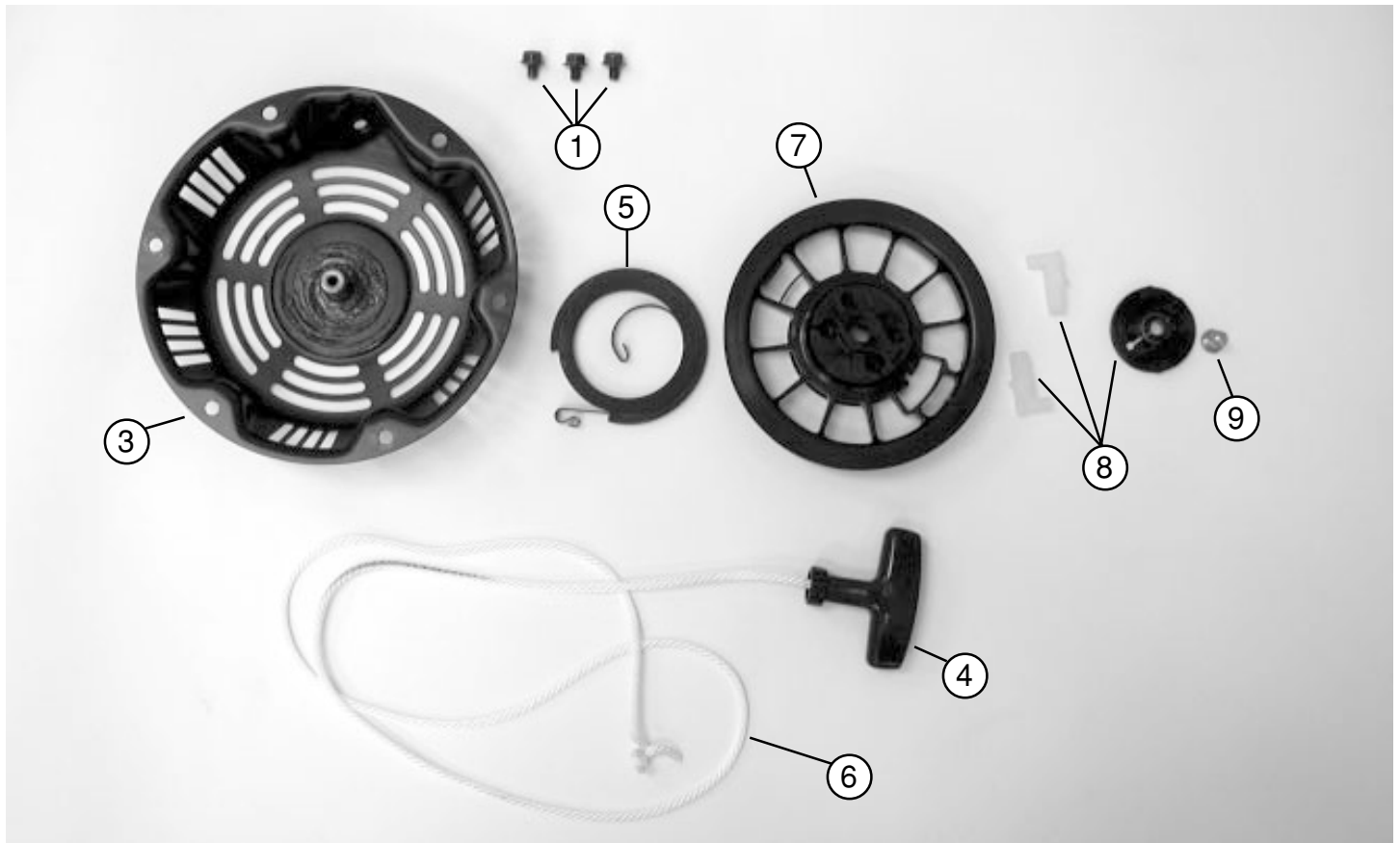

Item	Part Number	Name	Description	Qty
1	KOH6308619-S	Screw, hex flange		3
2	KOH6316502-S	Starter, retractable	includes 3-9	1
3	KOH6308105-S	Housing Assembly		1
4	KOH6316601-S	Starter, handle		1
5	KOH6308921-S	Recoil Spring		1
6	15585	Pull Rope		1
7	KOH6309302-S	Pulley		1
8	KOH6375706-S	Kit, pawl repair	includes 9	1
9	KOH6308652-S	Screw		1
10	KOH6310902-S	Starter Cup		1

# Front Seat

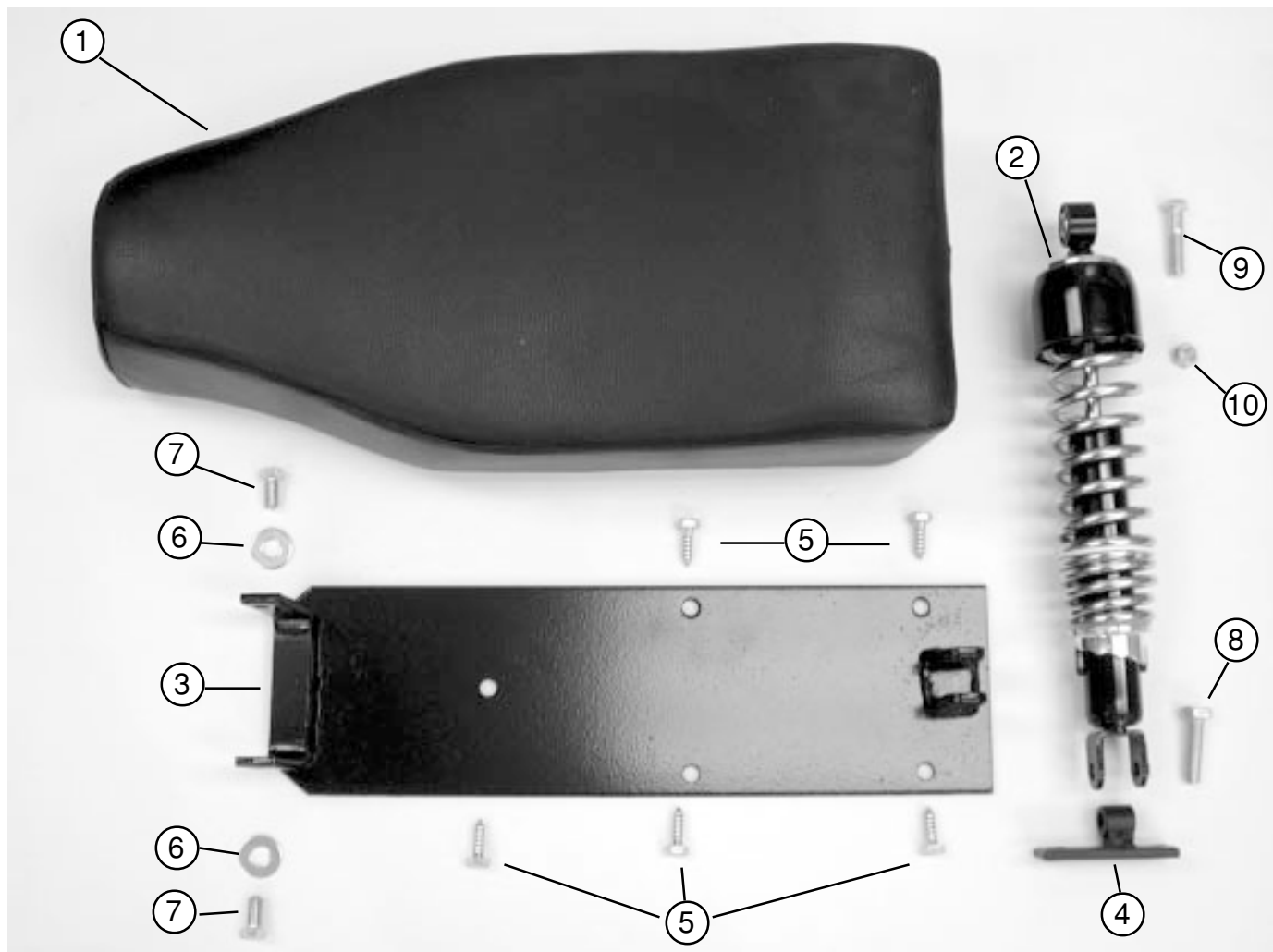

Item	Part Number	Name	Description	Qty
1	100451H	Front Seat		1
2	109002S	Shock		1
3	108063	Seat Base Plate		1
4	108062	Lower Shock Mount		1
5	101629S	Bolt	Lag	5
6	100208	Washer 1/2 Flat		2
7	101970	Bolt	HH Bolt 1/2-20 x 3/4	2
8	108999	Bolt		1
9	101181	Bolt	HH Bolt 3/8-24 x 1 3/4	1
10	100212	Nut	Lock Nut 3/8-24	1
11	100168	Bolt	Not Pictured for Lower Shock Mount	2
11	100169	Nut	Not Pictured for Lower Shock Mount	2

# Rear Seat

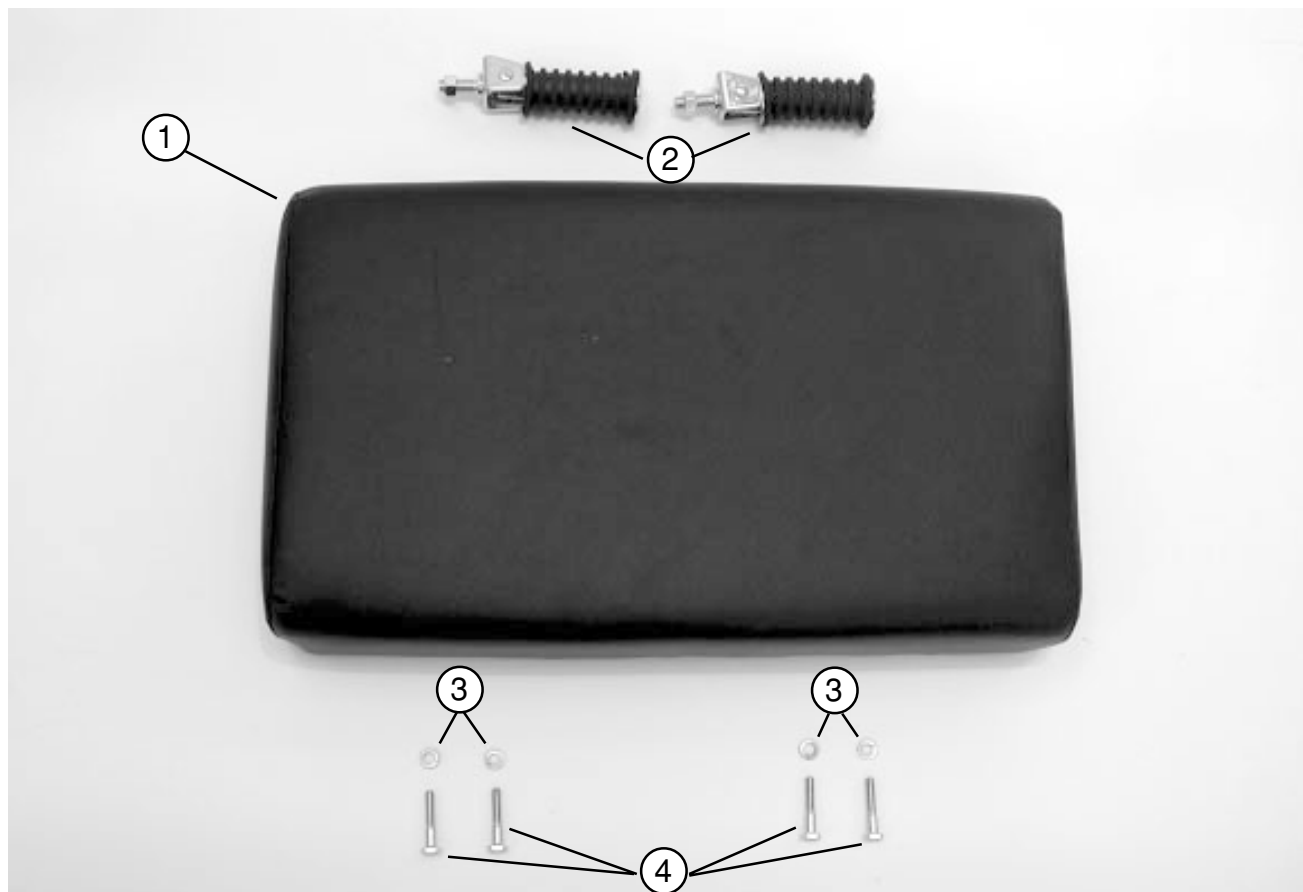

Item	Part Number	Name	Description	Qty
1	100340	Rear Seat		1
2	100343	Passenger Foot Peg Set		1
3	100281	Locking Washer	Lock Washer 1/4 Spring	4
4	105037	Hex Head Bolt	HH Bolt 1/4-20 x 1 3/8	4

# Torque Converter Drive Pulley

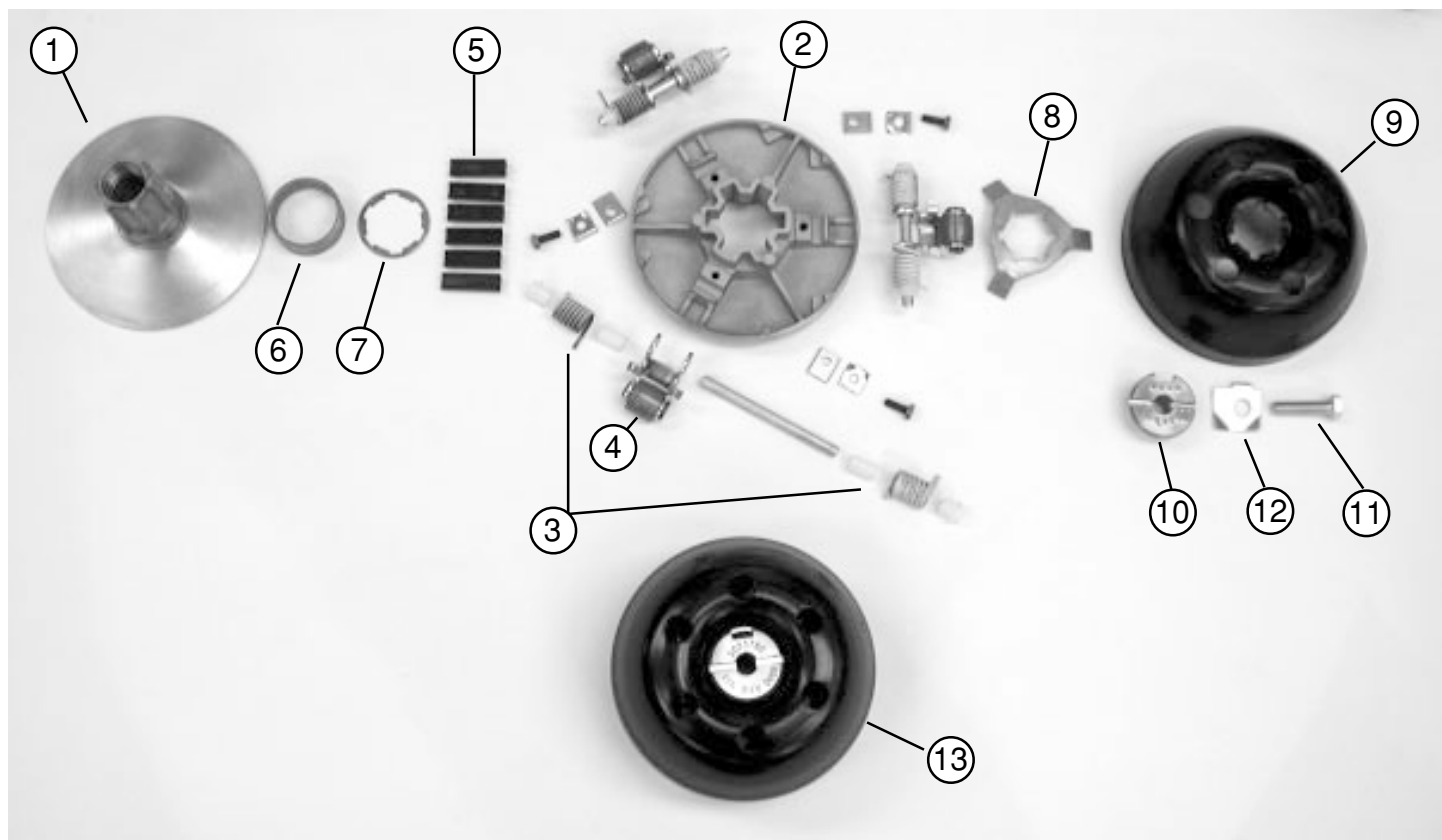

Item	Part Number	Name	Description	Qty
1	703209	Fixed Face and Hub Assy		1
2	601319	Moveable Face Assy		1
3	690144	Spring Kit	not shown	1
4	690146	Roller Arm Kit	not shown	1
5	703128	Liner Spline		6
6	703116	Bearing	Idler Bearing	1
7	703127	Washer		1
8	703129	Retractor		1
9	703151	Plate		1
10	703211	Washer	Ramp Plate Retaining	1
11	108123	Clutch Bolt		1
12	108983	Locking Clip		1
13	100885	Torque Converter Drive Complete	Includes 1-10	1

# Torque Converter Driven Pulley

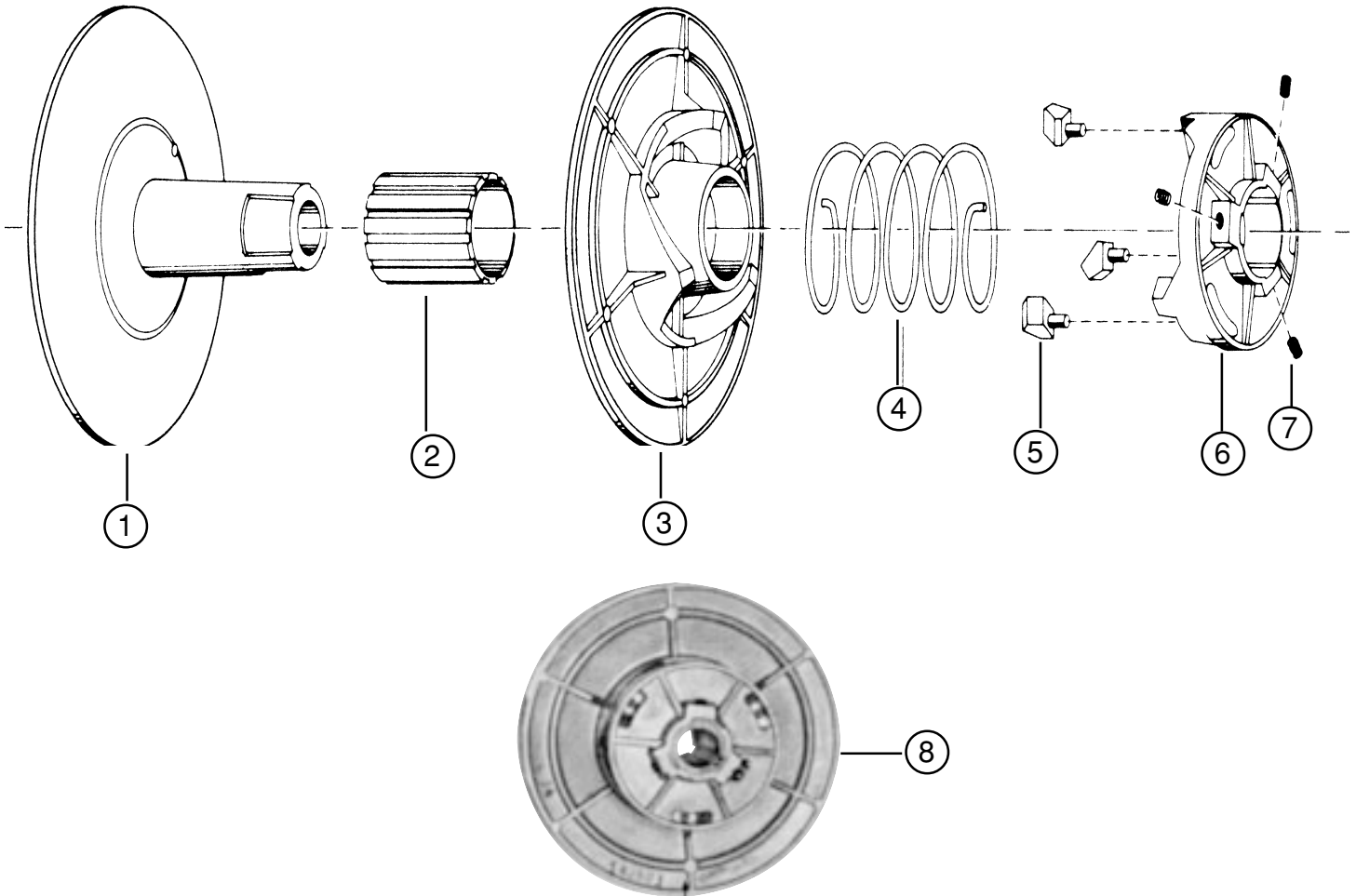

Item	Part Number	Name	Description	Qty
1	601311	Hub Fixed Face		1
2	703110	Bearing		1
3	703109	Movable Face		1
4	703111	Spring		1
5	703305	Button Shoe Ramp		3
6	601406	Torque Bracket	Includes Items 5 & 7	1
7	901709	Set Screw		3
8	100884	Driven Pulley	Rear Includes 1-7	1

# Tow Bar

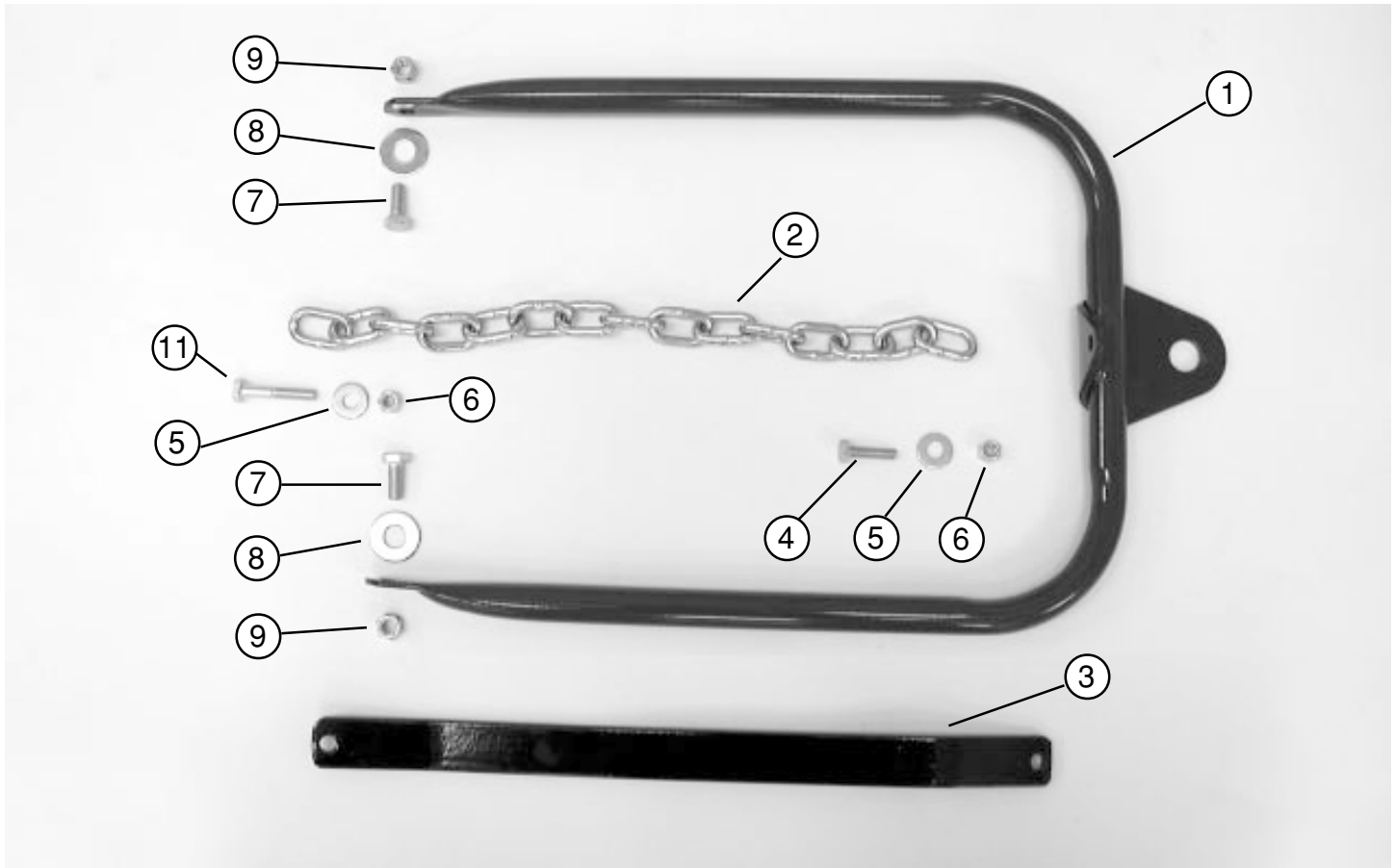

Item	Part Number	Name	Description	Qty
1	100349	Tow Bar		1
2	100007	Chain		1
3	103181	Rigid Tow Bar	Accessory	1
4	100166	Bolt	HH 1/4-28 x 1	1
5	100255	Washer		2
6	100169	Nut	Lock Nut 1/4-28	2
7	100848	Bolt	HHCS 5/16-24 x 3/4	2
8	100208	Washer	Flat Washer 3/8	2
9	100551	Nut	Locknut 5/16-24 Hex	2
10	100893	Tow Bar Kit	Includes all except 3	
11	100170	Bolt	HH 1/4-28 x 1 1/2	1

# Transmission Complete

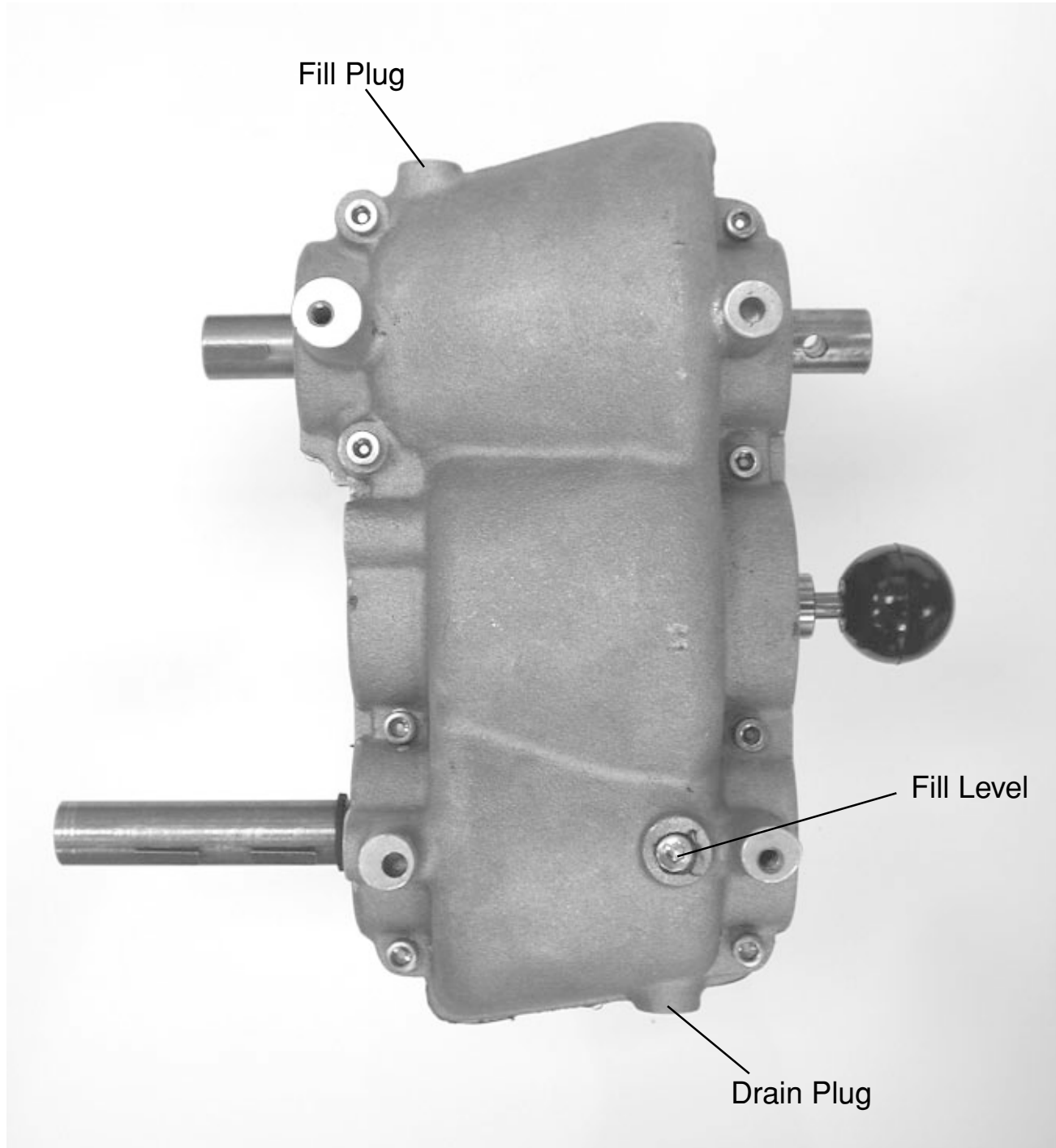

# Transmission with Attachments

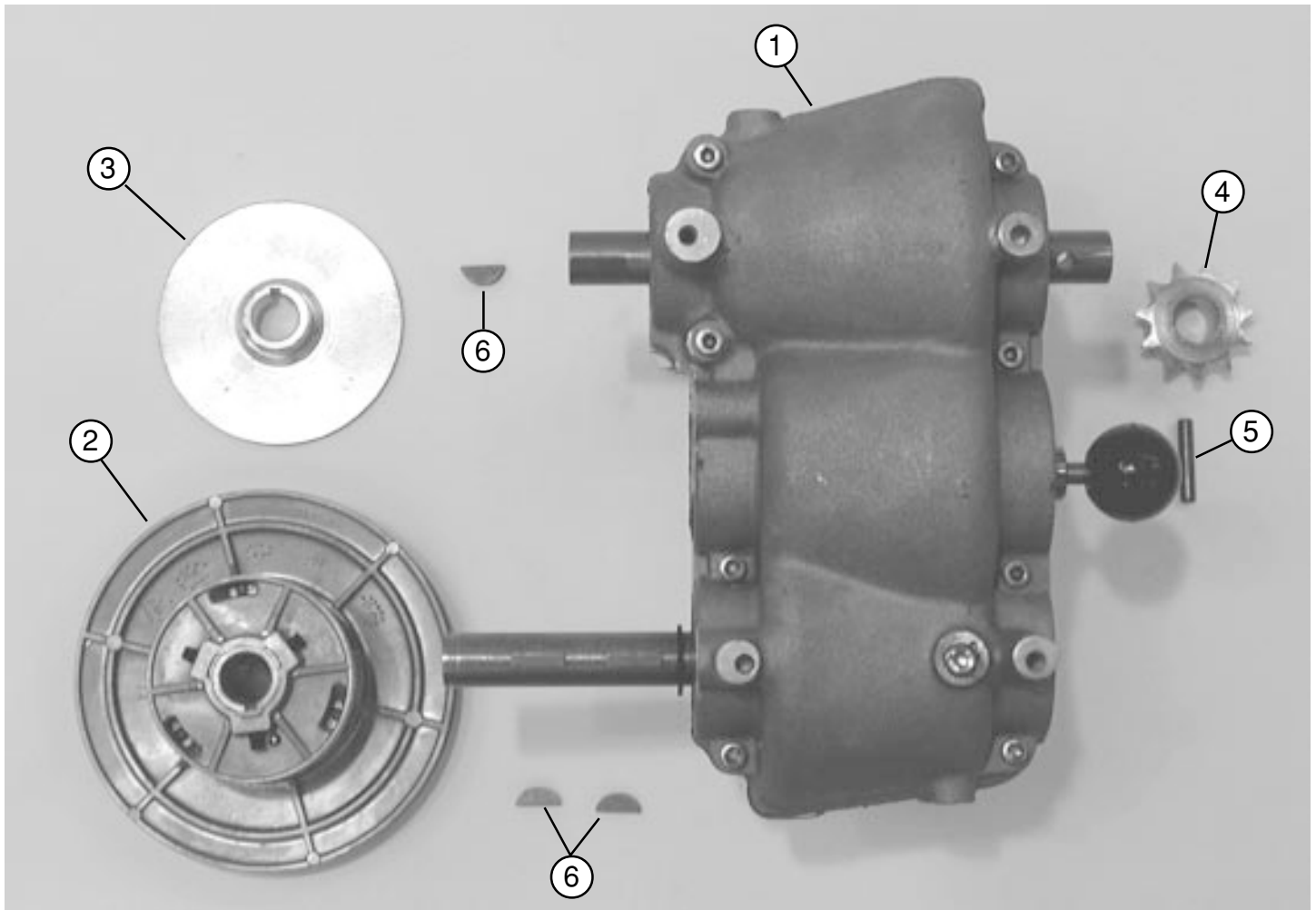

Item	Part Number	Name	Description	Qty
1	101680	Transmission Assembly		1
2	100884	Rear Driven Clutch		1
3	100610	Brake Disc		1
4	100040	11 Tooth Sprocket		1
5	100270	Roll Pin		1
6	100043	Woodruff Key		3



# Transmission in Sequence

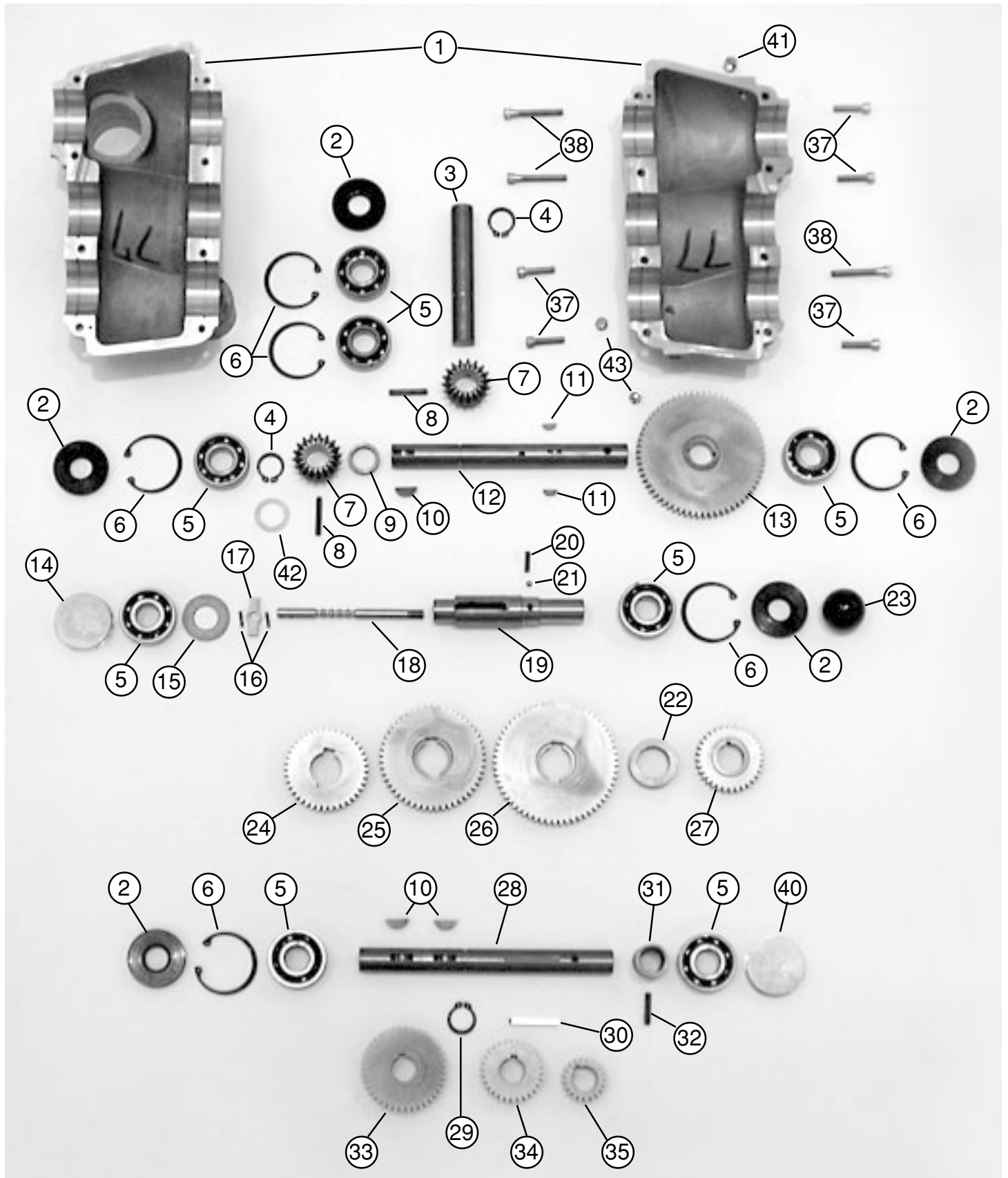

# Transmission in Sequence

Item	Part Number	Name	Description	Qty
1	101502	Transmission Casting Machined	2 halves	1
2	101523	Oil Seal		5
3	103142	Shaft	Front Output	1
4	103134	Snap Ring		2
5	100158	Bearing		8
6	103136	Snap Ring		6
7	100160	Miter Gear		2
8	100045	Roll Pin	3/16" x 1 1/4"	2
9	101519	Spacer		1
10	100043	Woodruff Key	#9	3
11	101506	Key	#3	3
12	103143	Shaft	Rear Output	1
13	101517	Gear	64T Drive	1
14	105082-2	End Cap		1
15	101511	Spacer		1
16	101637	Roll Pin	3/32" x 1/2"	2
17	101633	Gear Selector		1
18	101634	Shift Rod		1
19	101632	Selector Shaft		1
20	101528	Spring		1
21	101527	Ball		1
22	101530	Spacer		1
23	101541	Shift Knob		1
24	101631-3	Gear	40T	1
25	101631-2	Gear	51T	1
26	101631-1	Gear	60T	1
27	101516	Gear	32T	1
28	107039	Shaft	Input	1
29	101505	Snap Ring		1
30	101548	Key	Straight Cut	1
31	101510	Spacer		1
32	100047	Roll Pin	3/16" x 1"	1
33	101509-3	Gear	40T	1
34	101509-2	Gear	29T	1
35	101509-1	Gear	20T	1
36	100163	Plug		2
37	101525	Screw	1/4"-20 X 1"	1
38	101524	Screw	1/4"-20 X 1 3/4"	1
39	101939	Dowel Pin		2
40	105082	End Cap		1
41	108987	Pressure Relief Valve		1
42	101615	Shim	.005	1
43	100163	Plug		2

# Miter Box

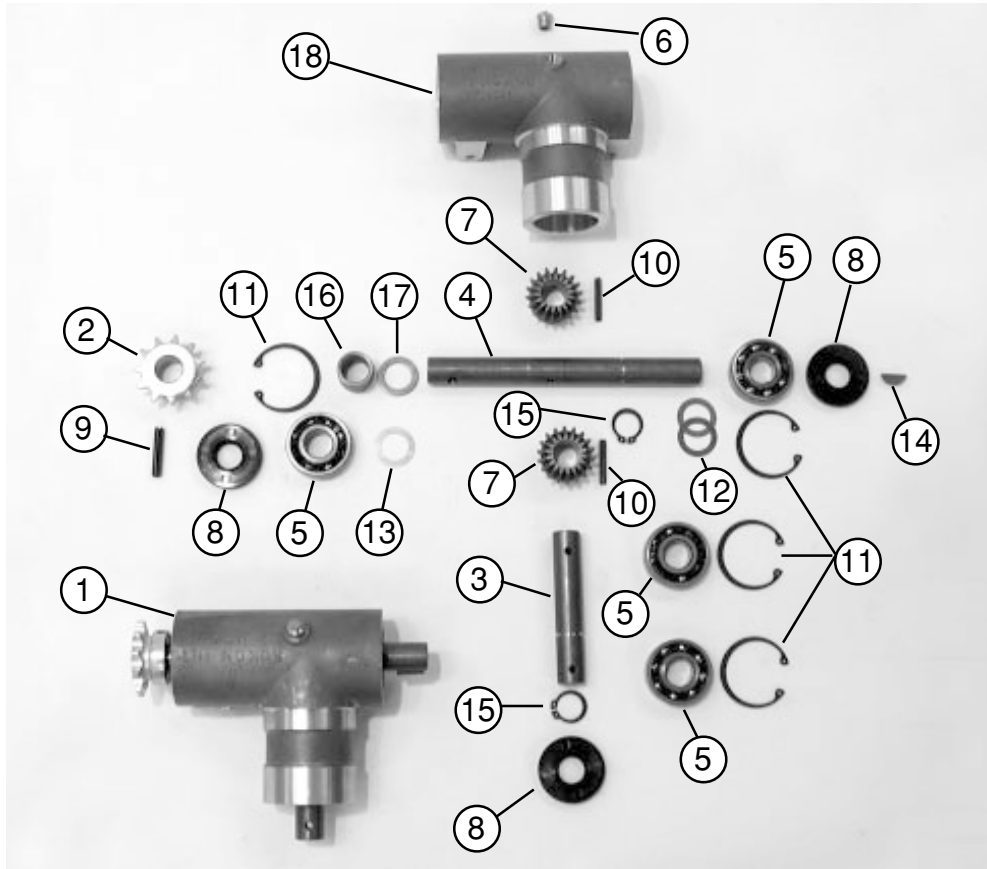

Item	Part Number	Name	Description	Qty
1	103131	Miter Box Assembly		1
2	100040	11 T Sprocket		1
3	108053	Miter Box Drive Shaft		1
4	103132	Miter Box Driven Shaft		1
5	100158	Bearing		4
6	108987	Pressure Relief Vent		1
7	100160	Miter Gear		2
8	101523	Oil Seal		3
9	100270	Roll Pin		1
10	100045	Roll Pin		2
11	103136	Snap Ring		4
12	101615	Shim ID 3/4" OD 1 1/8" .005	more as needed	1
13	101616	Shim ID 3/4" OD 1 1/8" .010	more as needed	1
14	100043	Woodruff Key	Connects to Brake Disc	1
15	101505	Snap Ring		2
16	100108	Spacer		1
17	100853	Spacer		1
18	100100	Miter Box		1

# Transmission to Miter Box

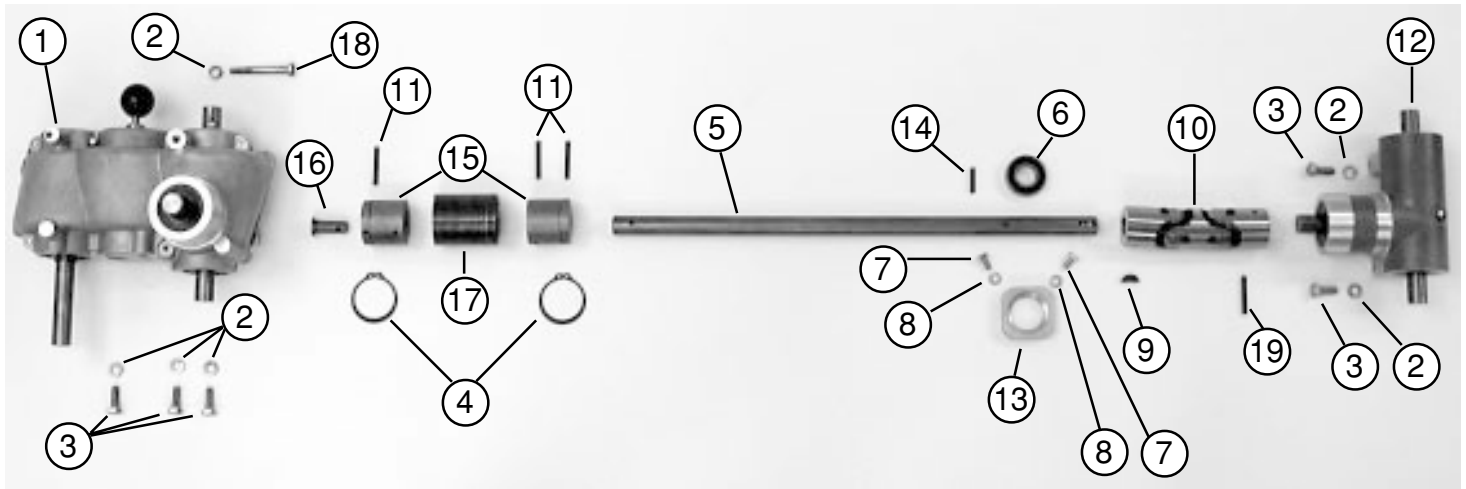

Item	Part Number	Name	Description	Qty
1	101680	Transmission Case Assembly	Three Speed	1
2	100039	Lock Washer	5/16	6
3	100038	Screw	5/16-18 x 7/8	5
4	100307	Snap Ring		2
5	108079	Drive Shaft	Four Stroke Models	1
6	100314	Drive Line Bearing		1
7	100252	Screw	1/4-20 x 1/2	2
8	100281	Lock Washer	1/4	2
9	100043	Drive Line Key	#9 Woodruff	1
10	108054	Universal Joint		1
11	100046	Roll Pin	3/16 x 1 1/2	3
12	100100	Miter Box Assembly	Front All Models	1
13	100312	Bearing Retainer	Drive Line Support	1
14	100047	Roll Pin	3/16 x 1	1
15	101655	Drive Line Boss		2
16	101656	Retaining Pin		1
17	100002	Override Spring		1
18	101529	Screw	HH Bolt 5/16-18 x 2 1/4	1
19	100045	Roll Pin		1
20	101640	Drive Line Assembly		1

# Aluminum Wheels

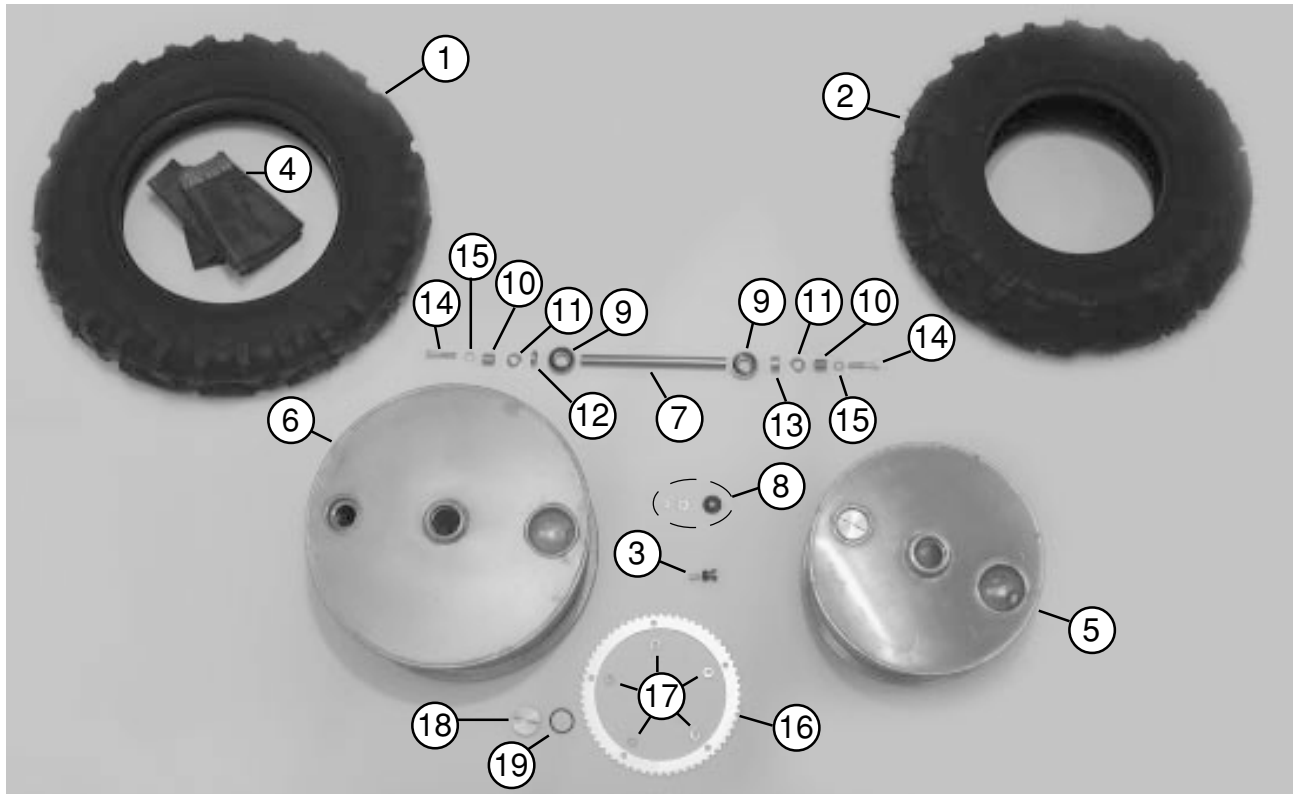

Item	Part Number	Name	Description	Qty
1	100519	Tire 5.90 X 15	Goodyear Implement	2
2	100836	Tire 8 X 12	Titan 489 XT	2
3	100542	Valve Stem	12" only	2
4	100521	Tube	15" only	2
5	108156	Aluminum Wheel 12"		2
6	108129	Aluminum Wheel 15"		2
7	100405	Axle		2
8	105030	Valve Stem Kit	15" only (not shown)	1
9	100772	Bearing		4
10	100522	Axle Spacer		4
11	100208	Washer		4
12	100756	Spacer	Dead Side	2
13	100758	Spacer	Sprocket Side	2
14	101181	Bolt	3/8-24 x 1 3/4"	4
15	100288	Lockwasher	3/8" Lock	4
16	108112	Sprocket	60T	2
17	100036	Jam Nut		10
18	100523	Plug		2
19	100516	O Ring		2

# Steel Wheels

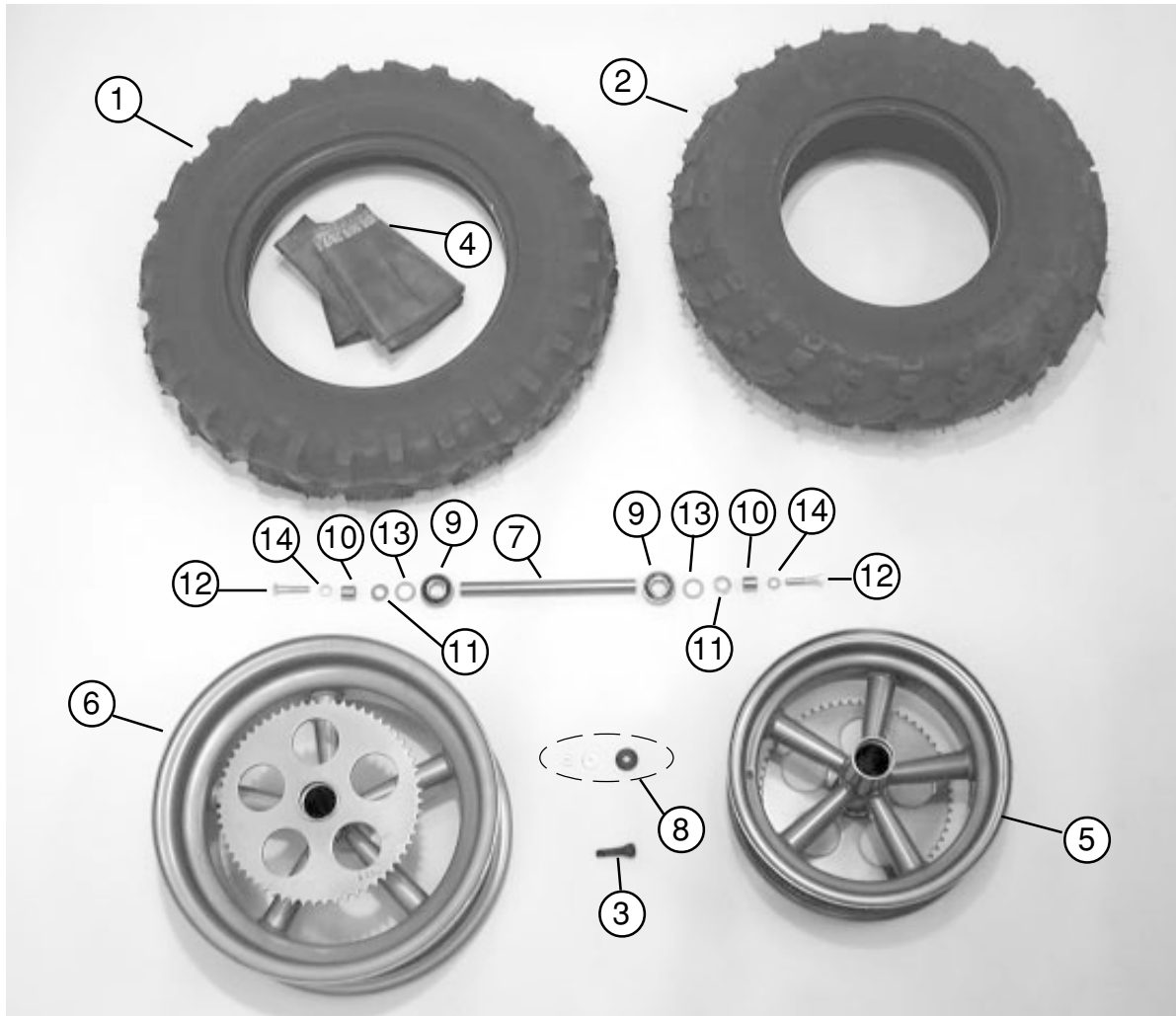

Item	Part Number	Name	Description	Qty
1	100519	Tire 5.90 X 15	Goodyear Implement	2
2	100836	Tire 8 x 12	Titan 489 XT	2
3	100541	Valve Stem	12" only	2
4	100521	Tube	15" only	2
5	100116	Wheel	12" Steel	2
6	100117	Wheel	15" Steel	2
7	100405	Axle		2
8	105030	Valve Stem Kit	15" only (not shown)	1
9	100772	Bearing		2
10	100522	Axle Spacer		2
11	100208	Washer		2
12	101181	Bolt	3/8-24 x 1 3/4"	2
13	100853	Shim		2
14	100288	Lockwasher	3/8" Lock	2

# Wiring Diagram

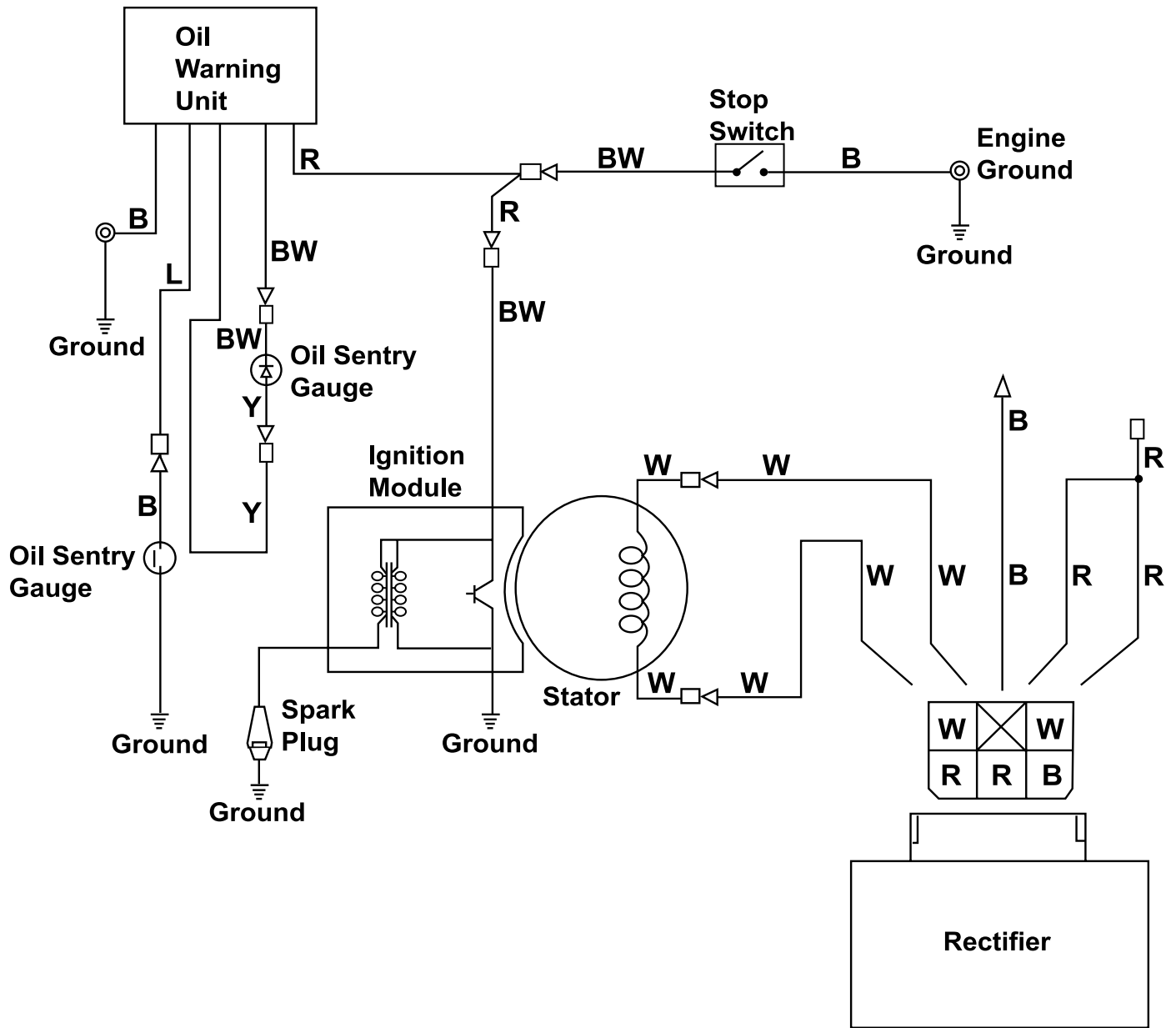





# STOP

## **IMPORTANT – PLEASE COMPLY WITH THE FOLLOWING OWNER PREPARATION STEPS PRIOR TO OPERATION OF YOUR NEW ROKON:**

- 1) READ AND BECOME THOROUGHLY FAMILIAR WITH THE MATERIAL IN YOUR OWNERS MANUAL.
- 2) REDUCE THE TIRE PRESSURE TO 3<sup>1</sup>/<sub>2</sub> PSI IN THE FRONT TIRE AND 2<sup>1</sup>/<sub>2</sub> PSI IN THE REAR TIRE.
- 3) HANDLEBAR INSTALLATION: HANDLEBAR HAS BEEN DISASSEMBLED FOR SHIPMENT. REINSTALL AND POSITION HANDLEBAR AND TORQUE HANDLEBAR MOUNTING BOLTS TO 20 FT/LBS. ALL WIRES, BRAKE CABLES AND THROTTLE CABLE MUST PASS BETWEEN HANDLE BAR MOUNTING TOWERS.
- 4) COMPLETELY FILL CRANKCASE WITH SAE 10W-30/40 MOTOR OIL. FOLLOW START UP PROCEDURES IN ENGINE MANUAL.
- 5) ADD UNLEADED FUEL TO TANK. USE SUPER UNLEADED FOR OPERATION AT OR ABOVE 10,000 FEET.
- 6) DURING THE FIRST FOUR (4) HOURS OF OPERATION, INSPECT THE DRIVE CHAINS FOR EXCESSIVE LOOSENING. ADJUST AND LUBRICATE DRIVE CHAINS PER OWNERS MANUAL.

**ROKON**<sup>®</sup>

50 RAILROAD AVE  
ROCHESTER, NH 03839

[www.rokon.com](http://www.rokon.com)

TEL: 603-335-3200

FAX: 603-335-4400