

NATIONAL TRANSPORTATION SAFETY BOARD

WASHINGTON, D.C. 20594

AIRCRAFT ACCIDENT REPORT

IN-FLIGHT LOSS OF PROPELLER BLADE
AND UNCONTROLLED COLLISION WITH TERRAIN
MITSUBISHI MU-2B-60, N86SD
ZWINGLE, IOWA
APRIL 19, 1993

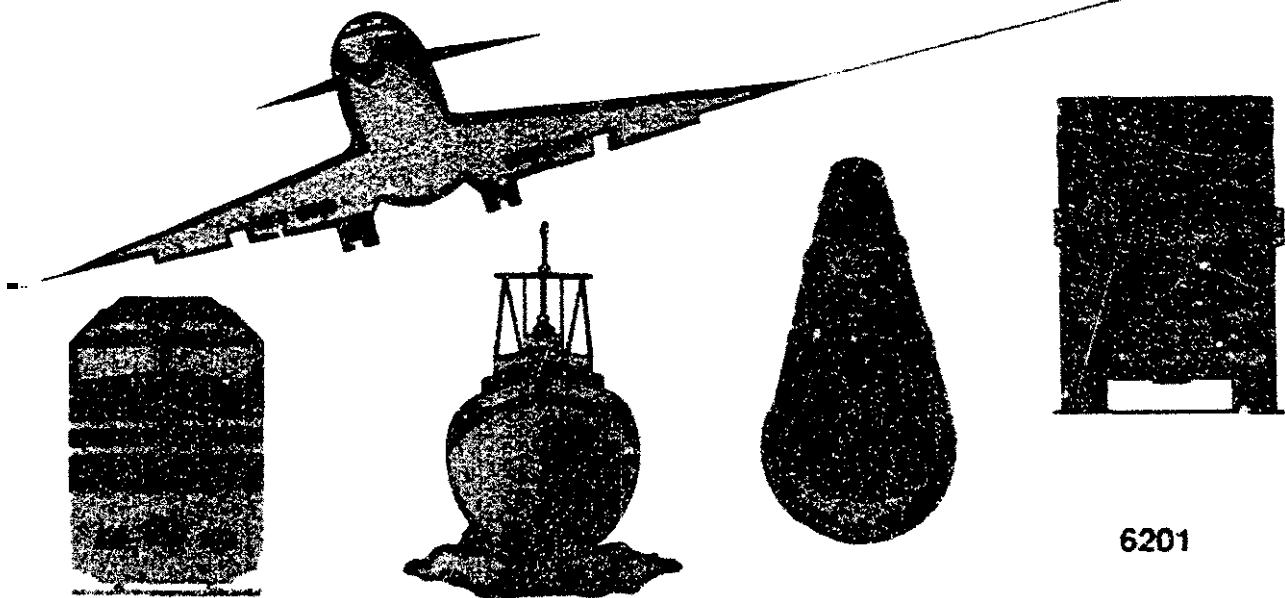

6201

The National Transportation Safety Board is an independent Federal agency dedicated to promoting aviation, railroad, highway, marine, pipeline, and hazardous materials safety. Established in 1967, the agency is mandated by Congress through the Independent Safety Board Act of 1974 to investigate transportation accidents, determine the probable causes of the accidents, issue safety recommendations, study transportation safety issues, and evaluate the safety effectiveness of government agencies involved in transportation. The Safety Board makes public its actions and decisions through accident reports, safety studies, special investigation reports, safety recommendations, and statistical reviews.

Information about available publications may be obtained by contacting:

National Transportation Safety Board
Public Inquiries Section, RE-51
490 L'Enfant Plaza, S.W.
Washington, D.C. 20594
(202)382-6735

Safety Board publications may be purchased, by individual copy or by subscription, from:

National Technical Information Service
5285 Port Royal Road
Springfield, Virginia 22161
(703)487-4600

**NATIONAL TRANSPORTATION
SAFETY BOARD
WASHINGTON, D.C. 20594**

AIRCRAFT ACCIDENT REPORT

**IN-FLIGHT LOSS OF PROPELLER BLADE
AND UNCONTROLLED COLLISION WITH TERRAIN
MITSUBISHI MU-2B-60, N86SD
ZWINGLE, IOWA
APRIL 19, 1993**

**Adopted: November 16, 1993
Notation 6201**

Abstract: This report explains the in-flight loss of propeller blade and subsequent crash of an MU-2B-60 airplane, operated by the South Dakota Department of Transportation, while the flight crew was attempting an approach to an emergency landing at Dubuque Regional Airport, Dubuque, Iowa, on April 19, 1993. The safety issues discussed in the report include the propeller hub design, certification and continuing airworthiness, and air traffic control training. Recommendations concerning these issues were made to the Federal Aviation Administration.

CONTENTS

	EXECUTIVE SUMMARY	vi
1.	FACTUAL INFORMATION	
1.1	h istory of the Flight	1
1.2	Injuries to Persons	6
1.3	Damage to Airplane	6
1.4	O ther Damage	6
1.5	Personnel Information	6
1.5.1	T he Flightcrew	6
1.5.2	The Air Traffic Controllers	8
1.5.2.1	Controller Emergency Procedure T rainng	8
1.6	Airplane Information	9
1.6.1	General	9
1.6.2	N86SD Maintenance Program	9
1.6.3	E ngine and Propeller Information	10
1.6.4	Weight and B alance	10
1.6.5	Maintenance R ecords Review	11
1.7	M eteorological Information	11
1.7.1	S urface Weather Observations	11
1.7.2	A IRMETs and S IGMETs	13
1.7.3	C enter Weather Advisory	14
1.7.4	Severe Weather Forecast Alert	14
1.8	Aids to Navigation	15
1.9	Communications	15
1.10	Aerodrome Information	16
1.11	Flight Recorders	16
1.12	Wreckage and Impact Information	17
1.12.1	Debris Field Description	17
1.12.2	Fuselage Damag	17
1.12.3	Wing Damage	20
1.12.4	Empennage Damage	20
1.12.5	E ngine Damage	21
1.12.5.1	L eft Engine M ount Damage	22
1.13	Medical and Pathological Information	24
1.14	F ire	24
1.15	S urvival Aspects	24

1.16	Tests and Research	25
1.16.1	Propeller Examinations	25
1.16.1.1	The Left Propeller	25
1.16.1.2	The Right Propeller.....	27
1.16.1.3	Propeller Configuration	27
1.16.1.4	Laboratory Examination of Left Propeller Hub and Blades	27
1.16.2	Recorded Radar Information.....	32
1.16.3	Fuel Analysis	32
1.17	Additional Information	33
1.17.1	South Dakota DOT Aviation Services Section Information	33
1.17.1.1	Aviation Services Section Training	34
1.17.2	Hartzell HC-B4 Propeller Description	35
1.17.2.1	General Description	35
1.17.2.2	Normal Loads	36
1.17.3	Certification of HC-B4 Propeller for MU-2B Application	37
1.17.4	Production History and Other Applications of HC-B4 Propellers	39
1.17.5	Previous Hartzell Propeller Blade Failures	41
1.17.6	Previous Failure of a Hartzell HC-B4 Propeller Hub	41
1.17.6.1	September 17, 1991, Accident	41
1.17.6.2	Resulting Safety Board Recommendations	42
1.17.7	FAA Action: Following the Zwingle, Iowa, Accident	43
1.17.8	Results of Postaccident Hub Inspections	44
1.17.9	Postaccident Hub Tests - Vibration and Stress Survey	45
1.17.10	Air Traffic Control	47
1.17.10.1	Procedures	47
1.17.10.2	Small Airport Information Available to Controllers	47
1.17.10.3	Air Traffic Controller Weather Retrieval Methodology	48
2.	ANALYSIS	
2.1	General	49
2.2	Analysis of the Hub Arm	49
2.2.1	Surface Discontinuities and Metallurgical Factors	51
2.2.2	Normal Operating Stresses as a Source of Crack Initiation	53
2.2.3	Reactionless Mode as a Source of Stress	54
2.2.4	Analysis of Corrective Actions	58
2.3	Pilot Actions	59
2.3.1	Effects of Damage on Drag and Rate of Climb	60
2.3.2	Effects of Damage on Lateral Control	61
2.3.3	Pilot Decisions on Flying the Airplane	62

2.4	Air Traffic Control Actions	63
2.4.1	Lack of Weather Sequence Reports Provided for Controllers	65
2.4.2	The Need for Additional Guidance for Controllers in Emergencies	66
3.	CONCLUSIONS	
3.1	Findings	68
3.2	Probable Cause	70
4.	RECOMMENDATIONS	71
5.	APPENDIXES	
	Appendix A. Investigation and Hearing	73
	Appendix B. Relevant Radio Transcripts	74
	Appendix C Safety Board Recommendations A-92-81 through	
	-83 Correspondence	92
	Appendix D. ATC Handbook 7110.65H, Emergency Assistance	114
	Appendix E. Hartzell Propeller Airworthiness Directives	119

EXECUTIVE SUMMARY

On April 19, 1993, at 1552 central daylight time, a Mitsubishi MU-2B-60, registered in the United States as N86SD and operated by the South Dakota Department of Transportation, as a public use airplane, collided with a silo on a farm near Zwingle, Iowa, while attempting an approach to an emergency landing at Dubuque Regional Airport, Dubuque, Iowa. The airplane was destroyed in the collision and postcrash fire. The captain, first officer, and the six passengers aboard were fatally injured. Instrument meteorological conditions existed at the time. The flight originated from Cincinnati, Ohio, at 1406, on an instrument flight rules flight plan.

The National Transportation Safety Board determines that the probable cause of this accident was the fatigue cracking and fracture of the propeller hub arm. The resultant separation of the hub arm and the propeller blade damaged the engine, nacelle, wing, and fuselage, thereby causing significant degradation to aircraft performance and control that made a successful landing problematic.

The cause of the propeller hub arm fracture was a reduction in the fatigue strength of the material because of manufacturing and time-related factors (decarburization, residual stress, corrosion, mixed microstructure, and machining/scoring marks) that reduced the fatigue resistance of the material, probably combined with exposure to higher-than-normal cyclic loads during operation of the propeller at a critical vibration frequency (reactionless mode), which was not appropriately considered during the airplane/propeller certification process.

The safety issues in this report include the propeller hub design, certification and continuing airworthiness, and air traffic control training. Safety recommendations concerning these issues were addressed to the Federal Aviation Administration.

NATIONAL TRANSPORTATION SAFETY BOARD
WASHINGTON, D.C. 20594

AIRCRAFT ACCIDENT REPORT

IN-FLIGHT LOSS OF PROPELLER BLADE
AND UNCONTROLLED COLLISION WITH TERRAIN
MITSUBISHI MU-2B-60, N86SD
ZWINGLE, IOWA
APRIL 19, 1993

I. FACTUAL INFORMATION

1.1 History of the Flight

On April 19, 1993, at 1552 central daylight time (CDT),¹ a Mitsubishi MU-2B-60, registered in the United States as N86SD and operated by the South Dakota Department of Transportation (DOT), as a public use airplane, collided with a silo on a farm near Zwingle, Iowa, while attempting an approach to an emergency landing at Dubuque Regional Airport (DBQ), Dubuque, Iowa. The airplane was destroyed in the collision and postcrash fire. The captain, first officer, and the six passengers aboard were fatally injured. Instrument meteorological conditions existed at the time. The flight originated from Cincinnati, Ohio, at 1406, on an instrument flight rules (IFR) flight plan.

The airplane and crew departed Pierre, South Dakota, on April 19 about 0630 to carry a delegation of state officials (including the Governor of South Dakota) and businessmen to a meeting in Cincinnati and to return the same day. The airplane stopped in Sioux Falls and Brookings, South Dakota, to pick up other members of the delegation. The airplane departed Brookings with the two pilots and six passengers aboard, and arrived about 0930 at Lunken Field in Cincinnati. The passengers then departed for their meeting.

The pilots remained at the airport where they ate lunch and ordered fuel for the return flight, requesting full inboard and outboard wing tanks, and 75 gallons in each wing tip tank. Refueling records revealed that the airplane was

¹All times in this report, with the exception of those in appendix B, are in central daylight time.
²See appendix A for information regarding the jurisdiction for the investigation of this accident.

serviced with a total of **303** gallons of Jet **A** fuel. No other maintenance service was requested. Personnel of the Million Air fixed-base operation at Lunken Field recalled that the flightcrew was relaxed, businesslike, and displayed good humor.

At **1201**, a caller, using the call sign **N86SD** and naming the **captain** as pilot-in-command, telephoned the Dayton, Ohio, **flight** service station (**FSS**) to file two **IFR** flight plans and to obtain weather information for Cincinnati to **Sioux Falls to Pierre**. The first route segment to **Sioux Falls** was specified as "RNAV direct." The caller *Ned tu* depart **Lunken at 1330**, with a flight time of 2 1/2 hours to **Sioux Falls**, with 4 1/2 hours of fuel on board. Three passengers were to deplane at Sioux Falls, and the flight was to resume at **1615** with **2** hours of fuel remaining for a 40-minute flight to Pierre. The call was concluded at **1208**. There were *no* discussions about alternate fields and surface weather observations from airports other than **Sioux Falls** and Pierre.

The passengers returned about 1345 and boarded the airplane. The flightcrew radioed ground control at 1355 for flight clearance and taxi instructions. At **1359**, the airplane held on runway 20 to await an **IFR** release that was received at **1406** from the Lunken air traffic control tower.

The airplane took off and proceeded west-northwest. At 1428, the flightcrew of **N86SD** requested and was granted clearance to deviate from course to avoid weather buildups at flight level (FL) **230** over Indiana. (See figure 1). At **1509** and **1537**, the flightcrew again requested and obtained clearance to deviate around poor weather conditions at FL 240 over Illinois.

At **1540**, the flightcrew reported, "Chicago, sierra delta, we had a decompression," then "Mayday, Mayday, Mayday. **Six** sierra delta, we're going down here." The Chicago Air Route Traffic Control Center (ARTCC) controller acknowledged: "Roger, tell me what you need." The flightcrew replied, "The closest airport we can get to here." The controller informed **N86SD** that **DBQ** was 25 miles away at their 2:00 position and asked what altitude the airplane needed. The airplane's position was actually **37** miles from **DBQ**. At this time, the controller was **unaware of** the weather at **DBQ**. The flightcrew responded, "We need to get down to our oxygen level." The center controller then cleared the airplane to 8,000 feet.

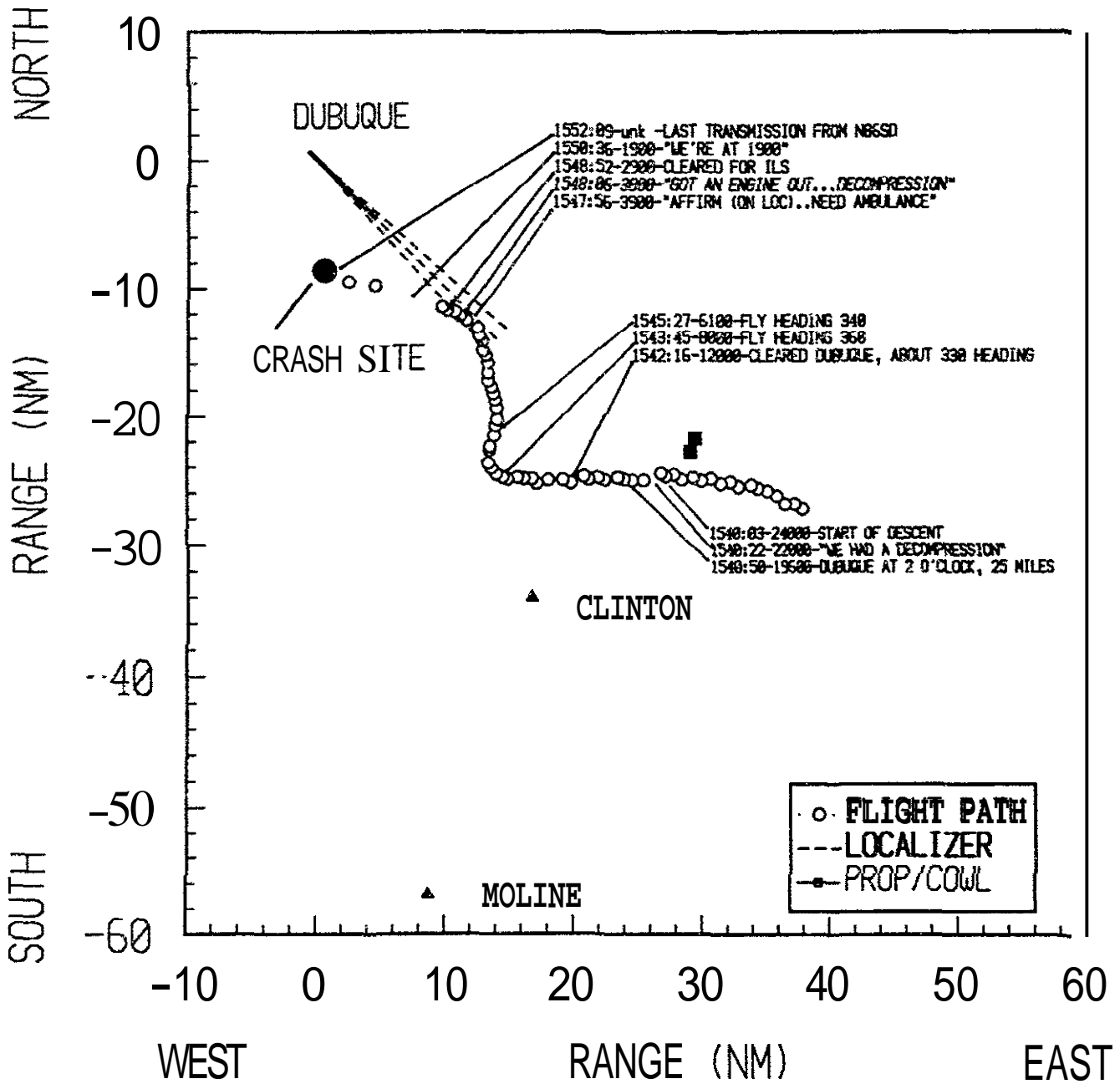

Figure 1.--N86SD ground track.

About **this** time, other airports were considered as divert options. The controller later stated that there were smaller airports in the area but that they were uncontrolled and unmanned. She considered Maquoketa Airport, but it only had a **nondirectional** radio beacon (NDB) instrument approach. She considered Quad City **Airport** (MLI), Moline, Illinois, but believed it was **farther** away from the airplane than DBQ.

At 1542:12, the flight requested DBQ weather conditions. The controller replied by clearing the **flight to** DBQ and stating that DBQ was at about a 330-degree heading, and that the airplane should fly "direct when able." She **also** reported the DBQ weather **as** 300 feet overcast, 1.5 miles visibility in rain and fog, **and** winds **of** 060 degrees at **20** knots.

At **that time**, DBQ was about 31 miles from the airplane. **Also** at that time, the current weather observation for MLI (about 33 miles away from N86SD) indicated visual meteorological conditions (YMC) on the surface. Also at that time, instrument landing system (**ILS**)-**equipped** Clinton Airport (CWI), Clinton, Iowa, was **9** miles south, with a ceiling of 400 feet, and a visibility of **5** miles. The air traffic controllers involved in the emergency situation did not query their computer for the MLI surface observation, which would have been available. The CWI surface observation is not available via a computer query.

About 1542, one of the controllers contacted Quad City approach control to point out to the approach controller that N86SD was descending, with the following land-line transmission: "Yeah, just, **ah** northeast of Davenport fifteen miles, that emergency squawk you're seeing, he's going down **to** eight right now."

At 1543:11, the controller asked the flight if it could change frequency. The flight answered in the **affirmative**, and contacted the low altitude radar controller. The DBQ radar controller assigned a heading to join the ILS final approach course for runway 31 at DBQ and asked **if** the flightcrew wanted emergency equipment standing by. The flightcrew replied, "We might need the equipment...."

At **1544**, the controller asked, "Can you hold altitude?" The flightcrew responded, "Well, standby." The controller then cleared the flight to 6,000 feet. At 1545, the airplane reported **difficulty** holding altitude, and the controller then cleared the flight **to** 4,000 feet and restated the heading to join the approach course.

Chicago ARTCC notified DBQ tower at 1545 that N86SD was diverting to DBQ with an emergency. At 1546, the flightcrew requested the distance to DBQ, and the controller replied that the airplane was 23 miles southeast of the airport. N86SD then requested vectors to the ILS. At 1547, the controller informed N86SD that his radar showed the airplane joining the approach course. N86SD acknowledged and asked, "...could you have an ambulance standing by?" At 1548:06, N86SD transmitted that they "had an engine out" as well as a decompression.

At 1549, the controller stated the airplane's altitude readout of 2,700 feet and asked "Can you hold...there?" N86SD answered, "I don't think so." Radar contact was lost at 1551, about 10 miles southeast of DBQ when the airplane was at 1,900 feet. The controller reported the loss of radar contact to the flightcrew and directed them to contact DBQ tower.

The flightcrew reported on DBQ tower frequency at 1551, was informed that emergency equipment was in position, and was cleared to land on runway 31. N86SD acknowledged and asked, "...how far out are we?" The tower controller, unable to answer the question because no equipment to determine the airplane's range was installed in the tower, stated that radar contact had been lost and asked if the airplane had distance measuring equipment. The flightcrew's affirmative response at 1552 was the last transmission received.'

A witness at Cottonville, Iowa, 4 miles east-southeast of the crash site, heard an airplane overhead about the time of the accident but did not see it because of clouds. A witness, 2 miles from the site, saw N86SD come out of the clouds to his east, pass about 100 feet overhead and continue west-northwest. He described the airplane as inclined right wing down, with the left propeller stopped. He stated that he saw a single left propeller blade, stationary above the left wing and bent forward.

Three witnesses driving south on US Highway 61 saw the airplane cross from east to west at low altitude, and later saw the eruption of fire at the crash site. One of these witnesses stopped on the side of the road and reported the accident to authorities by mobile telephone.

³Three individuals acquainted with both pilots listened to recorded communications between the airplane and Dubuque tower, and identified the first officer as the individual making the radio transmissions on N86SD.

The accident occurred during the hours of daylight at 42 degrees, 15 minutes, 21.6 seconds north latitude and 090 degrees, 41 minutes, 20.4 seconds west longitude. This location is about 8.5 miles south of DBQ. The elevation of the site was determined by a topographical map to be about 1,000 feet above mean sea level (msl).

1.2 Injuries to Persons

<u>Injuries</u>	<u>Flightcrew</u>	<u>Passengers</u>	<u>Other</u>	<u>Total</u>
Fatal	2	6	0	8
Serious	0	0	0	0
Minor/None	0	0	0	0
Total	2	6	0	8

1.3 Damage to Airplane

The airplane was destroyed during the impact and postcrash fire. Its estimated value was \$600,000.

1.4 Other Damage

A farm silo, a barn, several pieces of farm equipment, and several farm animals were destroyed. The estimated value of this property was \$160,000.

1.5 Personnel Information

1.5.1 The Flightcrew

The captain, age 52, held a second class medical certificate issued on December 10, 1992, with a limitation that he wear corrective lenses while flying. It could not be determined whether he was wearing corrective lenses during the accident sequence of events.

The captain held an airline transport pilot certificate, number 1972080, with endorsements for airplane single- and multi-engine land. The certificate was issued on September 5, 1979. He held a flight instructor certificate with ratings for single- and multiengine land airplanes, and an instrument rating. His total flight time was 10,607 hours, with 1,922 hours in the MU-2. In the last 30 days, he had

flown **26 hours**, **12** of which were in the MU-2. His instrument time totaled **921** hours in actual instrument conditions and **112** hours in simulated instrument conditions. He completed a recurrency check as **MU-2** pilot-in-command on **December 16, 1992**. He had been employed as a full-time pilot by the State of South Dakota DOT since March **1980**. He assumed the position of chief pilot in **1982**.

The captain had been married for 30 years and had two children. His son gave the following account of the captain's activity in the days before the accident. The captain flew a trip on the morning of April **16**, returned to his office by **1400**, and spent the evening at home. The son visited his father that evening, and his father mentioned a long trip the coming Monday. The captain went to bed between **2230** and **2300**, awoke early on Saturday, and spent the day at home. He and his wife grilled steaks for dinner, and he went to bed about **2330**. On Sunday, he and his wife attended church in the morning and visited friends that evening. The son said that his father probably went to bed at his usual time between **2330** and **2400**. He rose early on April **19**, withdrew money from an automatic teller machine at **0530** and went to work for a scheduled **0630** departure. The son recalled that his father was in the habit of beginning preflight preparations about an hour before departure.

The first officer, age **45**, held a second class medical certificate issued on **April 13, 1992**, without limitations.

He held a commercial pilot certificate, number **503606959**, with ratings for helicopter and airplane, single- and multi-engine land, and instrument airplane and helicopter. The certificate was issued on February 25, 1977. He held a flight instructor certificate with ratings for airplane, single- and multi-engine land, instrument airplane, and helicopter. His total flight time was **8,085** hours, with **982** hours in the **MU-2**. The first officer accumulated about **1,120** flight hours in rotorcraft as a U.S. Army pilot between 1968 and his military separation in the early 1970s. His instrument time totaled **270** hours actual and **180** hours simulated. He completed a recurrency check as **MU-2** pilot-in-command on December 16, 1992. While employed by the South Dakota Highway Patrol, he flew the accident airplane as a part-time pilot from 1983 through 1988. He joined the South Dakota DOT Aviation Services Section as a full-time pilot in November 1990.

The first officer had been married **21** years and had two children. His wife provided the following account of his activities in the **3 days** before the

accident. He flew a trip on Friday, returned home about 1700, and went to bed about 2230. **On** Saturday, he rose about 0500. He and his wife spent the day visiting a daughter at college and helping her move. They returned about **midnight**. On Sunday, he rose about 0900. He had lunch with another daughter, napped, and visited a friend in the evening. He went **to** bed about 2230. He left the house about 0430 on Monday. He told his wife that he had a long trip scheduled and that it would be a long day.

1.5.2 The Air Traffic Controllers

Federal Aviation Administration (FAA) facility records indicated that the Coton High position radar controller entered on duty with the FAA on December 4, 1986, and came **to** the Chicago ARTCC on June 8, 1987. She attained her area rating in the Northwest Area on June 30, 1991. Her most recent over-the-shoulder evaluation and tape talk were on November 11, 1992. Her most recent medical examination was on March 25, 1993, with no waivers or limitations.

The **DBQ** Low Sector radar controller entered on duty with the FAA at the Chicago ARTCC on December 30, 1959. His area **rating** in the **North** Area was on July 15, 1987. His most recent over-the-shoulder evaluation was on March 2, 1993, and his most recent tape talk was on April 7, 1993. **On** March 16th, 1993, he received his most recent medical, with the notation that he shall wear lenses that correct distant vision, and possess glasses that correct near vision while performing air traffic control (ATC) duties.

1.5.2.1 Controller Emergency Procedure Training

Supervisory personnel at the Chicago ARTCC stated that all controllers experience simulated emergencies during all phases of training. They said emergency situations are planned into simulation scenarios, and that situations very similar to the accident sequence of events are inserted into **training** sequences. Such situations resembling **the** N86SD sequence of events are also included in controller and supervisor annual refresher training, according to Chicago Center personnel.

1.6 Airplane Information

1.6.1 General

N86SD was purchased by the State of South Dakota on February 25, 1983, from Carlingswitch, Inc., the owner of the airplane since December 13, 1979. The airplane had been registered under four different numbers since its manufacture. The original registration number was N197MA. It was changed to N69PC after the airplane was sold to Carlingswitch, Inc. On January 26, 1983, the registration number was changed to N984MA, and, on June 10, 1983, it became N86SD after it was purchased by the State of South Dakota.

Communications and navigation equipment installed at the time of the accident included dual VHF radio transceivers, area navigation coupled to the autopilot, dual VOR receivers, DME, ADF/NDB, LORAN, ILS with marker beacon, and radar altimeter! The LORAN had a feature to display airports in proximity to the airplane's present position.

A telephone was installed in the airplane with handsets at the right pilot's station and the right rear passenger seat. The latter was used by passengers twice during the accident flight, but not during the accident sequence of events. See section 1.9. A cockpit indicator was installed to show the flightcrew when the telephone was in use.

1.6.2 N86SD Maintenance Program

Examination of N86SD's logbooks revealed that the airplane was inspected under Federal Aviation Regulations (FAR) Parts 91 and 43. The State of South Dakota's maintenance program for N86SD was found consistent with the manufacturers' (Mitsubishi, Garrett, and Hartzell) recommended maintenance programs. These programs are based on overhaul, life-limited, and on-condition maintenance processes.

⁴VHF - Very High Frequency; VOR - Very high frequency Omnidirectional Radio Range; DE-Distance Measuring Equipment; ADF/NDB - Automatic Direction Finding/Nondirectional Beacon; LORAN - Long Range Navigation; and ILS - Instrument Landing System.

1.6.3 Engine and Propeller Information

The airplane was powered by two Garrett Turbine Engine Division, model TPE-331-10-511M turboprop engines, rated at 940 shaft horsepower at takeoff⁵ each driving a Hartzell model HC-B4TN-5GL propeller (see section 1.17.2.1 for description of propeller). Airplane records disclosed that at the time of the accident, the left engine, Serial No. P-36130C, had accrued a total of 4,516 operating hours since new (TSN) and 929 hours since overhaul (TSO). The right engine, Serial No. P-36098, had accrued 4,546 hours TSN and 890 hours TSO. Both engines were overhauled by Teledyne Neosho, Neosho, Missouri, in November and December 1989, respectively.

The left propeller hub, Hartzell model HC-B4TN-5GL, Serial No. CD-975, was installed new by the airplane manufacturer at the time of original delivery and had remained with the airplane through its service life. At the time of the accident, *this* propeller hub had accrued a total operating time of 4,585 hours. Operating cycles were not recorded in the propeller records.

The overhaul of the MU-2's propellers was recommended every 3,000 hours of operation or 60 calendar months, whichever occurred first, according to Hartzell Service Letter (SL) 61R, dated February 28, 1992. There is no requirement to disassemble the hub to inspect the hub bores during the propeller overhaul. Records provided by the operator indicated that the last propeller overhaul on N86SD was performed at 3,914 hours of airframe total time (TT) on September 11, 1990, 671 hours before the accident.

1.6.4 Weight and Balance

Weight and balance were calculated for the accident flight using the following: 7,845 pounds empty weight, 1,422 pounds for flightcrew and passengers, and 2,425 pounds of fuel. The derived weights were 11,692 pounds at engine start and 10,825 pounds at accident. Center-of-gravity (CG) was calculated to be 195.2 inches at engine start and 196.3 inches at the time of the accident. The maximum takeoff weight for the airplane was 11,575 pounds, and its CG range was 190.9 inches to 199.4 inches.

⁵The engines are flat rated at 715 shaft horsepower, as installed on the MU-2B-60.

The South Dakota DOT pilots used a self-developed computer program to obtain weight and balance before flights from Pierre. Its use required entries for weights and the **distribution** of flightcrew, passengers, baggage and fuel. The program summed weights and calculated moment and CG. A representative calculation for a typical flight underreported **zero** fuel weight and **ramp** weight in the amount of one passenger's weight (first seat behind cockpit on **right** side), and miscalculated **CG** by **the** omission of moment for that passenger.

1.6.5 Maintenance Records Review

The maintenance records **for N86SD** included the airplane, propeller, engine, overhaul logbooks, **FAA form 337s** (Major Repair and Alteration), and **other** documents pertaining to the service history of the airplane. The last entry in the airplane logbook showed that **N86SD had** accumulated **4,570** hours TT on **April 12, 1993**, when a phase **5**, "Cabin & Cockpit" periodic inspection was accomplished.

The airplane logbooks described repairs **from** a gear-up landing of **N86SD**, with no reported damage **to** the propellers. **N86SD** was repaired on January **8, 1988**. At the time of the accident, the airplane logbook did not indicate my uncorrected discrepancies **or** open items.

The propeller logbooks showed that the **left** and right propellers were removed **for** newer model blade replacement by Aircraft Propeller Services, Inc., Wheeling, Illinois, on April 30, 1992, at the airplane TT of 4,340 hours, which was approximately 239 hours prior to the accident. The last recorded inspection **of** the propellers was performed on January 14, 1993. **The** inspection included an **examination of** the propellers **for** smooth rotation of the blades **or** the hub pilot tubes. The inspection of the propeller hub **for** cracks, required to be conducted **during** the 100-hour periodic inspection, **was** performed visually and was limited to the **exterior of** the hub **and** hub arm. The interior **pilot** tube **and** hub bore were not inspected at that time due to their inaccessibility.

1.7 Meteorological Information

1.7.1 Surface Weather Observations

DBQ Regional Airport (DBQ), Dubuque, Iowa:

1518 CDT...Special..Measured ceiling 300 feet overcast; visibility 1 1/2 miles; moderate rain, fog; winds 060 degrees at 20 knots; altimeter setting 29.45 inches of Hg.

1555 CDT...Record Special..Measured ceiling 200 feet overcast; visibility 1 1/2 miles; light rain, fog; temperature 46 degrees F; dew point 45 degrees F; winds 040 degrees at 16 knots; altimeter setting 29.46 inches of Hg.

1632 CDT...Special..Measured ceiling 300 feet overcast; visibility 2 miles variable; light rain, fog; winds 040 degrees at 20 knots gusting 27 knots; altimeter setting 29.44 inches of Hg.; visibility 1 1/2 miles variable 2 1/2 miles-

Quad City Airport (MLI), Moline, Illinois:

1516 CDT...Special..Measured ceiling 1,300 feet broken, 2,700 feet overcast; visibility 5 miles; fog; winds 180 degrees at 7 knots; altimeter setting 29.36 inches of Hg.

1550...Record..Measured ceiling 1,400 feet broken, 2,800 feet overcast; visibility 5 miles; fog; temperature 64 degrees F; dew point 60 degrees F; winds 180 degrees at 10 knots; altimeter setting 29.35 inches of Hg.

1650 CDT...Record Special..7,500 feet scattered, estimated ceiling 25,000 feet overcast; visibility 4 miles; fog; temperature 65 degrees F; dew point 61 degrees F; winds 180 degrees at 6 knots; altimeter setting 29.36 inches of Hg.

Clinton Airport (CWI), Clinton, Iowa:

1535 CDT...Ceiling 400 feet overcast; visibility 5 miles; temperature 54 degrees F dew point 51 degrees F; winds 070 degrees at 12 knots; altimeter setting 29.36 inches of Hg.

1540 CDT...Ceiling 400 feet overcast; visibility 5 miles; temperature 54 degrees F; dew point 50 degrees F; winds 070 degrees at 10 knots; altimeter setting 29.37 inches of Hg; .03 inches of precipitation measured between 1520 CDT to 1540CDT.

1555 CDT...Ceiling 300 feet overcast; visibility 5 miles; temperature 54 degrees F; dew point 50 degrees F; winds 060 degrees at 11 knots; altimeter setting 29.38 inches of Hg.

1.7.2 AIRMETs and SIGMETs

The following **airman's** meteorological information (AIRMET) and **significant** meteorological information (SIGMET) were *in* effect at **the** *time* of the accident:

AIRMET Zulu for Icing:

Issued on April 19, 1445 CDT, valid until April 19, 2100 CDT. "Occasional moderate rime icing in cloud and in precipitation from the freezing level to 18,000 feet" The area encompassed by this **AIRMET** included a 30 nautical mile radius of DBQ.

AIRMET Tango for Turbulence and Low Level Windshear (LLWS):

Issued on April 19, 1445 CDT, valid until April 19, 2100 CDT. "Occasional moderate turbulence below 10,000 feet in region of strong low level winds. LLWS potential over the area due to moderate to strong low level winds continuing beyond 2100 CDT." The area encompassed by **this** AIRMET included a 30 nautical mile radius of DBQ.

AIRMET Sierra for IFR:

Issued on April 19, 1445 CDT, valid until April 19, 2100 CDT. "Occasional ceiling below 1,000 feet/visibility below 3 miles precipitation/fog." The area encompassed by this **AIRMET** included a 30 nautical mile radius of DBQ.

Convective SIGMET 37C:

Issued on **April 19, 1455 CDT**, valid until **April 19, 1655 CDT**. From **30 nautical miles north of DBQ** to **30 nautical miles west-southwest of ORD** [Chicago, Illinois] to **20 nautical miles west of SBN** [South Bend, Indiana]: **Line** embedded thunderstorms **20 nautical miles** wide moving **from** 230 degrees at **30 knots** Tops to 40,000 feet.

Convective SIGMET 38C:

Issued on **April 19, 1455 CDT**, valid until **April 19, 1655 CDT**. From **30 nautical miles east of CID** [Cedar Rapids, Iowa] to **10 nautical miles southwest of BDF** [Bradford, Illinois] to **40 nautical miles south of BRL** [Burlington, Iowa] to **30 nautical miles east of CID**: Developing area of thunderstorms moving **from 230 degrees** at **25 knots**. **Tops** to 40,000 feet, tornadoes, hail **to 3 inches**, **wind gusts to 75 knots** possible.

1.7.3 Center Weather Advisory (CWA)

The following CWA, **issued** by the Chicago **Center (ZAU) Weather Service Unit**, National Weather Service meteorologist, was in effect at **the time of the accident**:

ZAU1 CWA 01/38C: **Issued on April 19, 1505 CDT**, valid until **April 19, 1705 CDT**. Over **ZAU** from **20 nautical miles north of DBQ** to **60 nautical miles northeast of IRK** [Kirksville, Missouri]. Rapidly **intensifying** broken line level **4 to 5** thunderstorms. Severe weather likely. Line moving east **25 knots**. Second line to develop next **2 hours** from **40 nautical miles northwest CID** to **40 nautical miles northeast of IRK**. Severe weather also likely as **cells** develop,

1.7.4 Severe Weather Forecast Alert

The following **Severe Weather Forecast Alert (AWW)** was in effect at **the time of the** accident:

AWW Number **142**: Valid on **April 19, 1400 CDT to April 19, 2000 CDT**. Tornado Watch **60 nautical miles** east and west of a line from **48 nautical miles south-southwest of SGF** [Springfield, Missouri] **to 40 nautical miles north of BRL**. Hail surface and aloft, **2 1/2 inches**. Wind **gust 75 knots**. **Maximum tops to 50,000 feet**.

1.8 Aids to Navigation

DBQ is equipped with the following instrument approaches: **an ILS to runway 31, an NDB to runway 31, a VOR to runway 36, a VOR to runway 31, a VOW to runway 13, and a LOC/DME BC to runway 13**. The only approach with weather minimums **at or above the minimum required at the time of the accident** was **the ILS to runway 31**.

MLI is equipped with the following instrument approaches: **an ILS to runway 09, a localizer to runway 27, an NDB to runway 09, and an RNAV to runway 31**. The weather at the time of **the** accident was above all approach **minimums**.

Instrument approach options at Clinton include **an ILS approach to runway 03, a VOR approach to runway 03, a VOR/DME approach to runway 21, an NDB approach to runway 03, and an NDB approach to runway 14**. The **ILS to runway 03 has a decision height that was at the ceiling at CWI at the time of the accident**. The **VOR to runway 03** would have also been available, provided **an airplane** was equipped with an **operating DME**.

1.9 Communications

Transcripts of pertinent recorded communications between the flightcrew and various FAA control facilities during the **in-flight** emergency are found in appendix **B** of **this** report.

South Dakota personnel **counted two** telephone calls **during the flight** that were **made** from the telephone installed in the airplane. About **1430**, the **office of one of the passengers** received a call from the passenger conveying that **the airplane was airborne out of Cincinnati**. About **1530**, another passenger called **his secretary in his office**. The **calls** were routine in nature **and did not indicate any airplane-difficulty**.

The accident site was in Jackson County, Iowa, which does not have 911 emergency service. The telephone call from the witness on the highway by the crash site was received by the Jones County Sheriff's Office, and the information was relayed to Jackson County at 1601.

1.10 Aerodrome Information

DBQ has no ATC radar. At the time of the accident, there were two controllers in the tower cab, and the tower manager was also on duty. The airport has two bidirectional runways: runway 13/31 (6,498 feet by 150 feet) and runway 18/36 (4,902 feet by 150 feet). Both runways are asphalt, and neither has an overrun. The field elevation is 1,076 feet msl. Runway 31 has a medium intensity approach lighting system with runway alignment indicator lights. Lighting on all runways was operational and had been turned to full intensity for the airplane's approach.

MLI is serviced by an ATC approach control radar. The airport has three bidirectional runways: 13/31 (concrete, 6,000 feet by 150 feet), 09/27 (asphalt, 8,509 feet by 150 feet), and 05/23 (asphalt, 4,909 feet by 150 feet). The field elevation is 589 feet msl. Runways 13/31 and 05/23 are equipped with medium intensity approach lighting, and runway 09/27 is equipped with high intensity approach lighting.

CWI is uncontrolled; however, a fixed-base operator on the field operates a UNICOM/CTAF [aeronautical advisory station/common traffic advisory frequency] radio. The airport has two bidirectional runways: 14/32 (asphalt, 3,700 feet by 100 feet), and 03/21 (asphalt, 5,204 feet by 100 feet). The field elevation is 708 feet. Pilot-controlled lighting is available for both runways. Weather information could be obtained directly from the airport via AWOS [automated weather observing system].

1.11 Flight Recorders

Flight recorders were not installed, nor were they required to be installed, on N86SD.

1.12 Wreckage and Impact Information

1.12.1 Debris Field Description

The airplane *came* to rest on a **heading** of **303 degrees** magnetic in a barnyard. During the **postcrash** fire, about 75 percent **of** the fuselage was consumed by fire. The **wreckage** path **began** at a demolished 75-foot concrete and steel **silo** and continued for about **498** feet on a magnetic **heading** of **between 290 and 320 degrees**. The farthest pieces of airplane debris that were found were the left and **right tip** tanks, which showed minor frontal damage and no fire damage. The fuselage was found to be heading **303** degrees and was largely consumed by fire from the front to the *aft* pressure bulkhead. (See figures 2 and 3).

The wreckage path **contained** pieces **of** the airplane **from** the nose to the tail and from the right wing tip **to** the left wing tip. One propeller blade, **one** blade tip, and the powerplant top cowling **from** the left engine nacelle could not be found at the accident site.⁶ Pieces of **silo** material were **found** throughout the wreckage **debris**.

1.12.2 Fuselage Damage

The fuselage structure was almost completely consumed by **fire from** the forward pressure bulkhead (forward of the rudder **pedals**) to the aft pressure bulkhead. The **nose of** the airplane was crushed inward into the cockpit area, a distance of about **4** feet. **Mortar**, concrete block and galvanized hardware were interspersed throughout the **nose** and cockpit areas. The fuselage area contained molten aluminum and unrecognizable fragments **of** metal. The empennage was *separated from the* fuselage at the factory joint (**the** attachment area between fuselage and **tail** structure) **and** was about **59** feet from the fuselage.

The fuselage debris was, for the **most** part, consumed by fire, eliminating the possibility of evidence of a propeller strike. No propeller material was **found in** the fuselage area.

⁶The left engine powerplant cowling and the missing L-3 propeller blade, blade clamp, and separated hub arm were found on May 14, 1993, about 4 miles north of the flightpath, about 27 miles east-southeast of the crash ~~site~~.

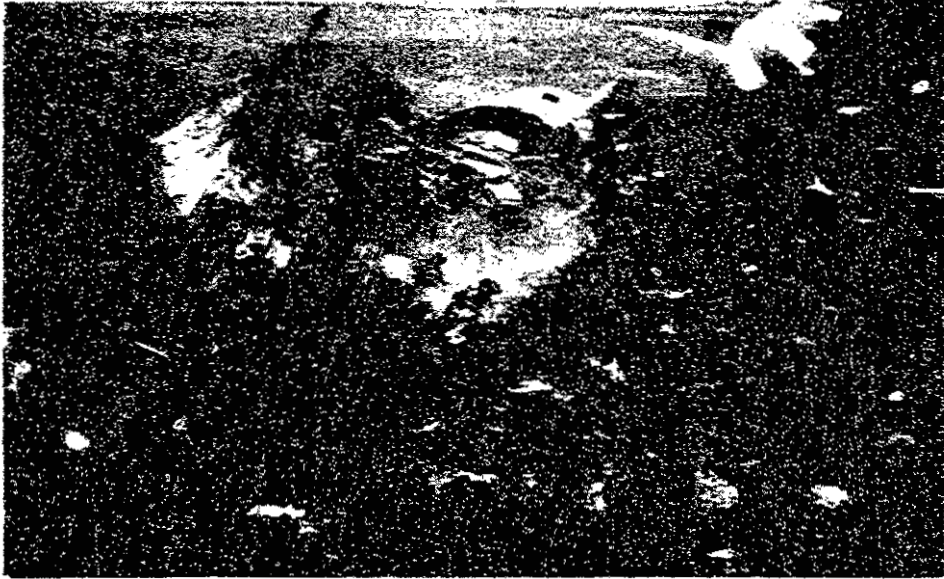

Figure 3.--Airplane wreckage.

1.12.3 Wing Damage

The **left** wing was found separated outboard of the left engine. The inboard portion of the wing, including the engine attach area, was found with the fuselage. It exhibited fire damage, consisting of scorched and melted metal, extreme crushing to the leading edge, and ruptured **fuel tanks**. The outboard wing section was **not** fire damaged and had minor damage to the leading edge. The left wing tip fuel tank separated from the wing at its attach points. The left aileron trim tab was positioned at **the full-tab-down** position (left wing up). The left inboard flap had separated from *the* wing **and** was found **in the** barnyard. The left outboard *flap* was partially separated from the wing and was attached by the left rail **trim** electrical cable. The left flap jackscrews were found in the flap retracted **position**. The **left** inboard spoiler was separated from the attachment **points**. The **left outboard** spoiler was attached to the wing. All of the fractures exhibited characteristics of overload failures.

The right wing was separated outboard of the right engine. The inboard **portion of** the wing, including the engine attach area, was found with the fuselage and exhibited **fire** damage, consisting of scorched and melted **metal**, extreme crushing to the leading edge, and **ruptured fuel tanks**. The outboard portion **of** the wing was not fire damaged and had minor damage to the leading edge. The **right** wing tip fuel tank separated from **the wing** at its attach points. The right aileron **trim** tab was positioned at the full tab up position (**right** wing down). The right inboard and outboard flaps were found separated from the wing. The **right** flap jackscrews were found in the retracted position. The right inboard spoiler was found separated from the wing. The right outboard spoiler was **integral** to the wing. All of the separated flight control surfaces were found throughout the wreckage path.

1.12.4 Empennage Damage

The empennage was found separated **from** the fuselage at **its** factory joint. The attach structure of the empennage-to-fuselage joint had broken in tensile overload. **The left** and right horizontal stabilizers and the **vertical** stabilizer leading edges were crushed rearward to their respective **front spars**. The left horizontal stabilizer was bent rearward 90 degrees with the rotation about the rear spar. The left elevator separated **from** the stabilizer **and was found** near the empennage. **Both** the left and right elevator counterweights were found near the empennage. The elevator trim setting was measured and was determined to be unlike either elevator

trim tab position. Continuity of the trim system could not be verified due to fire and impact damage, and the trim cables were found disconnected and free.

1.12.5 Engine Damage

Both the left and right engines were approximately 175 feet from the silo and adjacent to the severely burned cockpit/cabin section of the fuselage, the central point of the crash site. Both the left and right propellers were attached to their respective engine output shafts. Initial examination disclosed that the propeller blade operating cylinder and piston assembly, and the entire No. 3 blade, had separated from the left propeller. The remaining three blades were attached but severely damaged. The right propeller, except for the cylinder and piston assembly, was complete. However, all four blades were severely damaged.

The left engine was broken into three major pieces and the major fracture point was in an irregular tangential line through the inlet duct and around the tunnel housing that encloses the main engine rotor drive for the reduction gearbox (RGB). Two of the three major sections were found at approximately 83-degree angles to each other on a heading of 150 degrees and 67 degrees, respectively. They were connected only by miscellaneous tubing and electrical wire bundles. The third piece, the lower left section of the RGB, was about 6 feet east-northeast of the RGB section. The RGB separated as a basic assembly with the propeller attached to the engine output shaft.

The right engine was split into two pieces, the propeller/RGB section and the power section. The propeller/RGB assembly came to rest on a heading of 256 degrees and was adjacent to the right side of the burned section of the airplane cockpit. The power section was approximately 10 feet east-southeast of the RGB assembly on a heading of 211 degrees. The engine fracture line was along a ragged vertical plane through the engine inlet duct and accessory housing, basically in line with the face of the rear cover of the accessory mount section of the housing. The right propeller with all four blades was attached to the engine output shaft. The RGB section was found inverted and partially imbedded into the soft ground surface. The fracture and surrounding cracks in the housing were typical of overload separations.

1.12.5.1 Left Engine Mount Damage

The left side panel beam separated from the front wing spar, with the beam hinge type attachment and bolt intact; the separation occurred at the wing spar riveted joint. (See figure 4). The left beam was bent at mid length to the right (*aft* looking forward) approximately 50 degrees and slightly twisted in a clockwise direction. The cover and vibration isolator were intact and relatively free of damage. The engine mount spindle plate was attached to the vibration isolator, however, the spindle plate separated from the accessory gear box (AGB) when the threaded inserts were stripped from the cast aluminum AGB housing. The inserts made multiple imprints at the attach point on the engine. The right beam also separated at the wing spar in tension and in a forward direction. The separation was at the web just *aft* of the vertical bolt. However, the right beam was not bent or twisted. The spindle or the right beam spindle plate failed at the minor diameter, and the separated piece of the spindle remained with the vibration isolator.

The triangular truss support fractured into several pieces on impact, and all of the pieces were not recovered. The largest piece recovered was the apex section of the triangle that housed the front top vibration isolator and was attached to the top front engine mount.

The separation occurred almost equidistant from the Center of the apex and several inches behind the rear face of the isolator housing. Both side sections of the truss between the isolator housing and the left and right side beam attachment fitting were either not recovered or not identifiable. The truss end fitting that attached to the right side beam fractured in overload through the bolt hole. Ninety percent of the right fitting and a portion of the truss were recovered. The truss end fitting for the left side beam was intact and attached to the beam. However, sections of the triangular truss on either side of the left beam fitting were missing and not recovered.

The rear engine mount was separated with evidence of multiple rubbing marks. The left and right engine mounts from the left engine were placed in their respective positions relative to the left wing. Damage to the wing leading edge indicated that the left mount had rotated about 30 degrees inboard.

The "horse collar" broke on both sides of the top vibration isolator housing and at its attachment point on the nacelle. Two major pieces were recovered and were twisted and deformed.

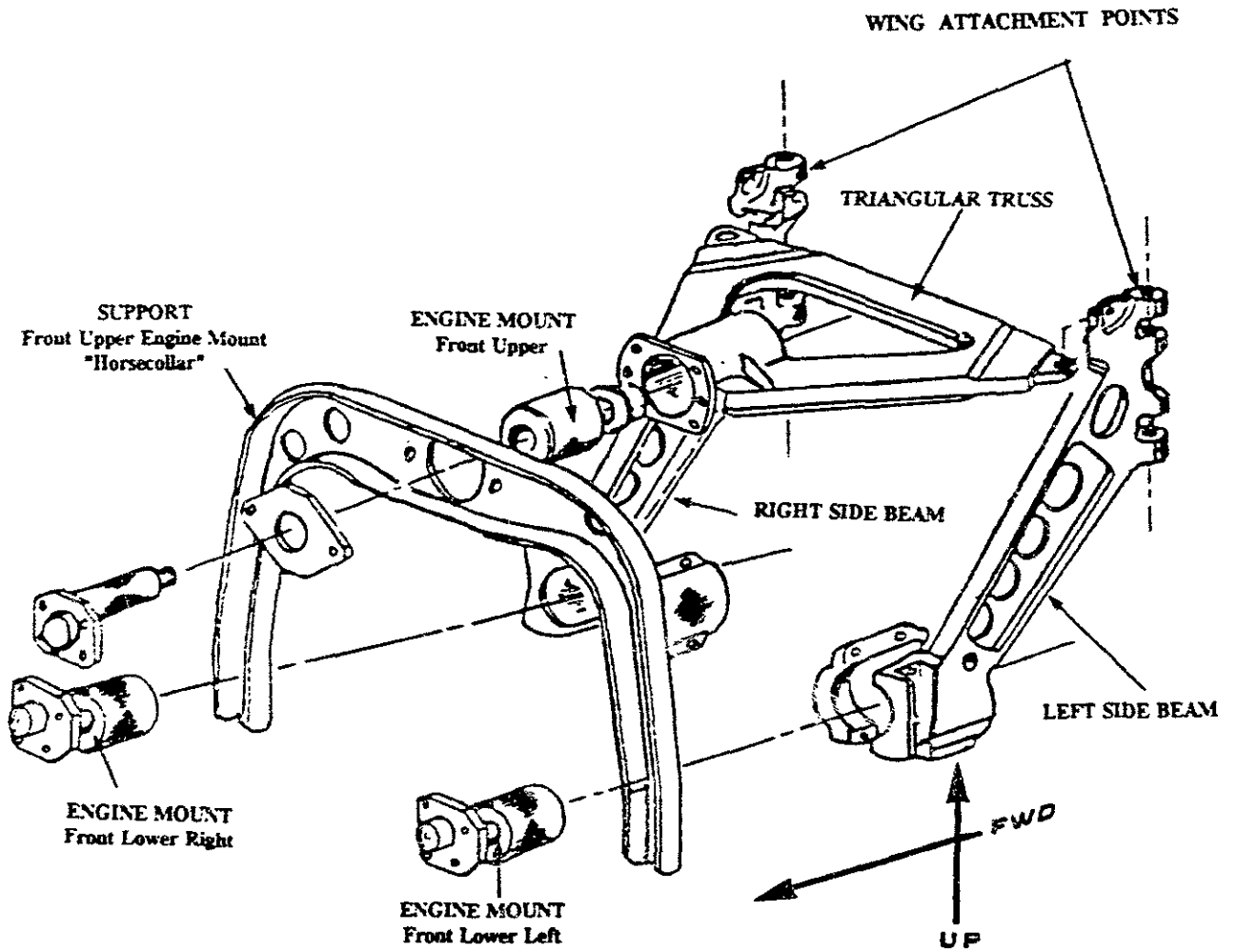

Figure 4.--Engine mount diagram.

1.13 Medical and Pathological Information

Toxicological testing on samples taken posthumously from the captain was completed by the St. Luke's Regional Center, Sioux City, Iowa. A urine sample tested negative for alcohol and other major drugs of abuse. Additional testing was completed by the Toxicology and Accident Research Laboratory of the FAA Civil Aeromedical Institute (CAMI). A sample of muscle fluid tested negative for alcohol, and a sample of liver fluid tested negative on a drug screen, including major drugs of abuse. The Iowa State Medical Examiner listed the probable cause of death as severe traumatic injuries.

Toxicological testing on samples obtained posthumously from the first officer was completed by the St. Luke's Regional Center. Urine and vitreous fluid samples tested negative for alcohol, and the urine sample was negative on a drug screen, including major drugs of abuse. Additional testing was completed by the Toxicology and Accident Research Laboratory at CAMI. A urine sample tested negative for alcohol and major drugs of abuse. The Iowa State Medical Examiner listed the probable cause of death as severe traumatic injuries.

1.14 Fire

Following impact, there was an intense fuel-fed, postcrash fire. No horizontal soot or heat patterns were found on any airplane part; however, most of the fuselage had been consumed by fire. Airplane parts found away from the fuselage fuel tanks exhibited no fire damage. Fuselage windows, which separated during the impact sequence, were not heat crazed or soot damaged.

1.15 Survival Aspects

Because of the dynamics of the impact, the accident was considered nonsurvivable.

Two fire-fighting vehicles were available at DBQ. One of them carried 150 gallons of water and 450 pounds of dry chemical, and the other carried 1,000 gallons of water. Both vehicles were capable of generating fire-fighting foam. Both vehicles were positioned on the field for the airplane's arrival. The airport equipment did not move to the crash scene.

At 1550, airport personnel requested additional vehicles and an ambulance from the Dubuque Fire Department, 8 miles northeast of the airport. A paramedic ambulance, two command vehicles and a pumper truck responded. As the vehicles arrived, they received notice over their radios that the crash site was located farther south and was being responded to by local fire departments. The ambulance and a command vehicle then continued on to the site. A pumper and a tanker responded from the Key West Volunteer Fire Department (VFD). Also, a pumper, a tanker and two rescue vehicles responded from La Motte VFD on local reports of a fire at the crash site. In addition, two tankers responded from the Bernard and Maquoketa VFDs.

1.16 Tests and Research

1.16.1 Propeller Examinations

1.16.1.1 The Left Propeller

The left propeller was attached to the engine output shaft with all eight bolts configured per Airworthiness Directive (AD) 83-08-01R1. A blade was found missing from the propeller hub.⁷ The separation point was approximately 1 inch outboard of the bottom of the hub bore for the No. 3 blade pilot tube.

The majority of the propeller spinner dome had separated from the propeller and was not recovered; however, a small section of the spinner dome remained with the bulkhead and was crushed between the L-1 and L-4 propeller blades. The spinner bulkhead was attached to the propeller hub and was extensively damaged. A portion of the bulkhead was crushed rearward between the L-2 and L-4 blades, through the area of the missing L-3 blade.

The piston and cylinder portion of the blade pitch change mechanism separated on impact. The propeller cylinder, feathering springs and the beta tube were recovered from the crash site as an assembly. The cylinder was dented and buckled, and the feathering springs were partially extended. The beta tube remained with the cylinder spring assembly and was bent. The piston was fragmented, and only about 25 percent of it was recovered. The L-1 and L-4 blades did not rotate in

⁷The propeller blades will be identified in this report by the designation, L-1, L-2, L-3, L-4 and R-1, R-2, R-3 and R-4. The letters L and R designate the propeller position on the airplane--i.e. right and left, and -1 through -4, indicate the blade position on the propeller.

their respective blade clamps, but the **L-2** blade had rotated in its clamp approximately 45 degrees toward the low pitch position. Propeller blade rotation was determined by checking the relative position of the rotation stripe on each blade.

The L-1 blade was relatively intact. There was moderate to heavy scratching in random directions on the blade rear camber that occurred between 1/4 and 1/2 blade span. The inboard half of the leading edge sustained some nicks and indentations, while the trailing edge was relatively smooth. The blade bearings were normal; and removal of the blade from the hub pilot tube was not restricted.

The leading and trailing edges of the L-2 blade at the tip end were curled toward the face side of the blade, which had a smooth "S" bend toward the back side of the blade. The bend started at the outboard end of the deicing boot and terminated about 8 inches from the blade tip. There were two large gouges in the leading edge with scrapes on the front side of the blade emanating from the gouges and moving aft and toward the hub. The scrapes form an angle of about 30 degrees from the blade chord. The leading edge of the blade was moderately gouged and dented throughout the span. The blade bearings were normal; however, removal of the blade from the hub pilot tube was restricted.

The L-4 blade had 8 to 10 inches of the blade tip missing. The remainder of the blade was bent forward about 30 degrees from the outboard end of the deice boot. The missing blade tip was not recovered. There were deep spanwise diagonal gouges (inboard to outboard) on the face of the blade traveling from the leading edge to the trailing edge, and from the edge of the fractured tip about 5 inches inboard. The blade was difficult to remove from the hub pilot tube. In addition, there were gouges on the full span of the leading edge.

The L-1 link arm was attached to its respective clamp and was bent outward, and a section of the fragmented piston was attached to the arm. The cotter pin was shared, and the link screw hole was elongated. The L-2 and L-3 link arms were not recovered. The L-2 link screw was normal but the cotter pin was sheared. The L-4 link arm was attached to its clamp and, except for minor surface irregularities, was not damaged.

The L-1, L-2 and L-4 blade clamps were attached to their respective blades, and the L-3 blade clamp was missing. The counterweights were intact and

normal on blades L-1 and L-4, and the ears on the saddle weight of the L-2 counterweight were missing.

Examination of the faces on the tip area of the L-1 and L-2 propeller blades revealed several minute areas bearing a light green substance (similar in appearance to zinc chromate paint) in the scratched surface of the blade? On the L-2 blade, the scratched surface was up to 4 inches from the tip with the scratches oriented on the blade in a generally chordwise direction. X-ray energy dispersive spectroscopy of these deposits indicated that they contained the following elements (approximately in order of decreasing peak height): carbon, oxygen, aluminum, silicon, zinc, chromium, potassium, calcium, and titanium. Zinc and chromium are elements found in primer for the aluminum skin of the airplane.

1.16.1.2 The Right Propeller

The right propeller was properly attached to the engine output shaft with all eight bolts configured per AD 83-08-01R1. The propeller had sustained extensive damage from impact but was mostly complete with all four blades attached. The piston and cylinder assembly separated on impact but was recovered at the accident site. The right propeller spinner dome separated on impact, and only a small section, which was crushed between blades R-1 and R-4, was attached to the propeller. The spinner bulkhead was intact but was deformed rearward between blades R-1 and R-2 and extending toward the R-3 blade.

1.16.1.3 Propeller Configuration

During the left and right propeller disassembly, the configuration of the propeller was checked for conformance with the propeller's most recent and current records. This review disclosed that model numbers, part numbers, and serial numbers conformed with the information recorded in the applicable propeller overhaul record and/or the propeller logbook and were correct for the installation.

1.16.1.4 Laboratory Examination of Left Propeller Hub and Blades

The components examined from the airplane's left propeller, Hartzell model HC-B4TN-5GL, were:

⁸Zinc chromate paint is commonly used on aircraft structure as a corrosion preventative,

- I. Propeller hub, P/N D-3405-1, S/N CD 975, with a separated hub arm.
2. Propeller blade (Design Number LT10282N B-5.3R, S/N H43468), blade clamp, and associated bearings from the separated ~~am~~ This ~~is~~ the L-3 blade assembly found remote from the impact site.
3. Propeller blades from the three intact arms of the hub.

The examination of the left propeller revealed that the fracture in the separated hub ~~ann~~ was the result of a fatigue crack that initiated from the inside diameter of the pilot tube hole in the hub arm. Figure 5 is a drawing of a cross section through the hub arm of the Hartzell HC-B4 propeller, with the location of the fracture indicated. Figure 6 is a view looking inboard on the fracture surface on the main portion of the propeller hub. The circumferential location of the origin area of the fatigue crack was at the 7:30 position, looking inboard at the fracture, with forward at the 12:00 position. This portion of the hub arm would experience maximum tensile stresses during normal operation of the propeller (forward thrust). The axial location of the origin was about 0.028 inch outboard of the bevel on the inboard end of the pilot tube. The fatigue cracking propagated through about 45 percent of the hub arm cross section before final fracture occurred.

The origin area contained a large number of ratchet marks," indicative of fatigue crack initiation from a large number of individual initiation sites. The approximate width of the origin area was 0.33 inch.

A portion of the fracture adjacent to the fatigue origin area contained a distinct, semicircular, darkly discolored area that extended over a width of 0.75 inch and to a depth of slightly less than 0.2 inch from the pilot tube hole surface. There appeared to be two separate curvilinear initiations of fatigue cracking from the end of the discolored fracture area. The larger initiation stemmed from an area of the discolored crack front closer to the 7:00 position of the hub and the other, which was smaller, was closer to the 8:00 position. Initial fatigue cracking from these reinitiation areas was relatively clean (not discolored); however, after a short distance, the fracture was again discolored in thin rings, after which the fatigue

⁹Ratchet marks are small vertical steps in the fracture that usually separate individual fatigue initiation sites on slightly offset planes.

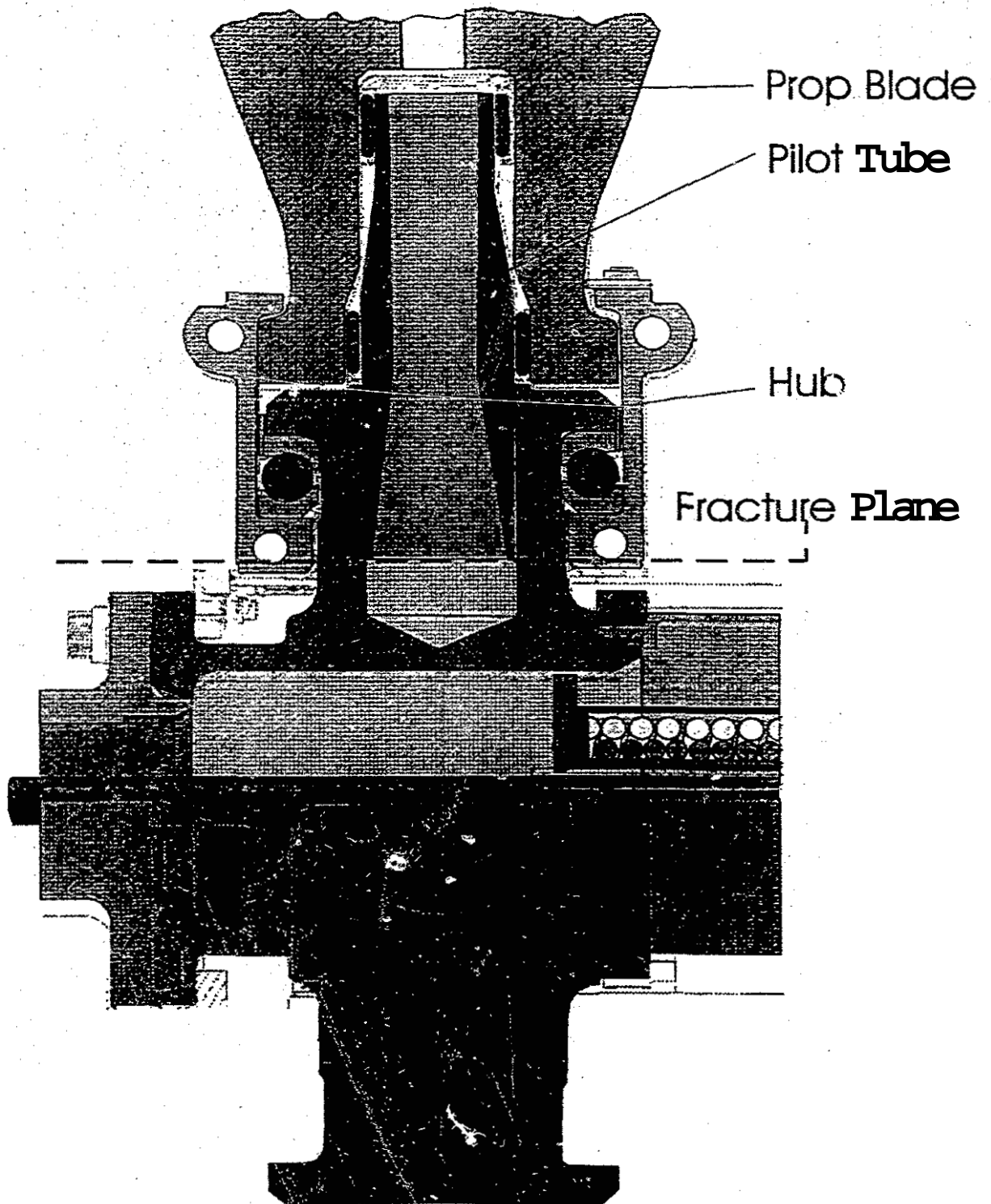

figure 5.--Cross section of propeller hub arm.

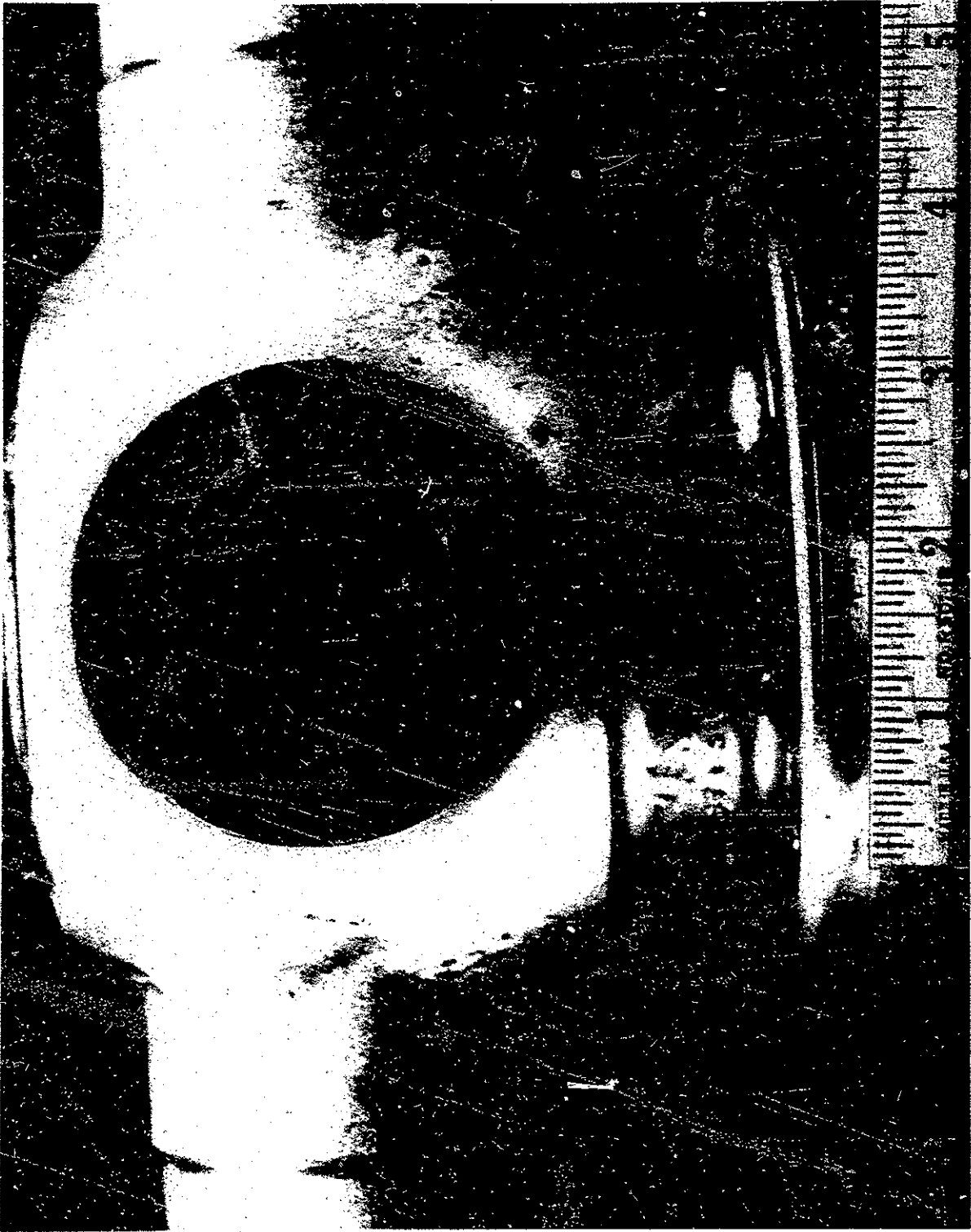

Figure 6.--Hub arm fracture surface. Arrow indicates fracture origin.

crack fronts appeared to merge to a single crack front. The remaining fatigue fracture outside these rings contained lesser amounts of discoloration with increasing distance from the origin. Examination of the fracture with a scanning electron microscope showed that some areas of the fatigue crack region outside the darkly discolored portion contained features with an intergranular appearance (fracturing between grains).

The surface of the pilot tube hole in the vicinity of the fatigue crack origin area contained general corrosion damage (primarily in the form of corrosion pits). However, the number of individual initiation sites was far greater than the number of corrosion pits. A narrow gap with corrosion deposits extended between the inboard end of the pilot tube and the inside diameter surface of the pilot tube hole in the hub arm. The surface of the pilot tube hole also contained burnished machining marks.¹¹ The origin area was along one of these machining marks for a substantial portion of its width.

Disassembly of the propeller hub revealed no evidence of bearing damage. Measurements of the propeller hub revealed no dimensional anomalies that might have contributed to the initiation of the fatigue crack. Inspection of the hub revealed no indications of additional cracks. The hardness of the hub was slightly below the hardness range specified on the hubs engineering drawing.

A metallographic evaluation of the hub material revealed that about 95 percent of the microstructure contained a somewhat feathery appearance, typical of bainite.¹¹ The remainder of the microstructure (about 10 percent) appeared to be martensite.¹² The size of the colonies of martensite was about the same as the size of the intergranular features observed on the fracture face in the fatigue regions. A thin layer of decarburization (loss of carbon) was found on the pilot tube hole wall surface in the hub arm.

The propeller blade that separated from the left propeller in flight was intact and contained slight damage to the electrical deicing boot. Other than slight damage associated with the boot, no mechanical damage was noted on the blade. In

¹¹ Burnishing refers to a rolling process that smoothes the machining marks on the hole surface.

¹¹ A mixed microstructural phase that is produced when steel at an elevated temperature is cooled quickly and held at temperatures usually between 500 degrees Fahrenheit (F) and 700 degrees F.

¹² A supersaturated solid-solution that is produced when steel at an elevated temperature is cooled quickly to temperatures below about 400 degrees F.

particular, the leading and trailing edges of the blade showed no **signs** of contact with any solid object,

1.16.2 Recorded Radar Information

The Chicago ARTCC recorded voice and radar data for portions **of** the flight of N86SD. **The** data show that N86SD was cruising at 24,000 feet about **10** nautical miles (nmi) west of MIHAL intersection, Illinois, **at a** ground speed **of** about **215 knots and** a ground track **of** about 295 degrees true (T). The ground track changed to about 270 T. The airplane began descending at about 4,500 feet per minute (fpm) followed **by** the pilot reporting a decompression of the airplane. **The** rate of descent remained constant to **9,000** feet. From **7,000** feet to **2,700** feet where radar coverage was lost, the descent rate was constant **at** about **900** fpm.

Air traffic controllers providing vectors **to** intercept the **ILS** course to runway 31 at **DBQ** told the pilot that he was intercepting the course, and asked for a confirmation of the course interception. The pilot reported intercepting the localizer course to runway 31 with, "That's affirm." **At** that time, the airplane was about 4,000 feet msl, about 3,000 feet below the glideslope. Subsequently, the airplane ground track deviated about **30** degrees to the left of the localizer course, although the descent rate remained at about 900 fpm.

Between the time that the airplane passed 2,700 feet and the time of the pilot's **call** of "**1,980** feet" about 1550:37, the descent rate would have been around 700 feet per minute (fpm). In addition, a descent rate of about 200 fpm would be consistent with the airplane passing the witnesses who were about **4** miles and **2** miles, respectively, southeast of the crash site.

1.16.3 Fuel Analysis

Analysis **of** the fuel recovered from the tip *tanks* indicated that the fuel in **both** tanks had densities, particulate contaminant concentrations, and lost volume percentages (during the distillation tests) that were within established specifications **for an** airplane fuel sample.

1.17 Additional Information

1.17.1 South Dakota DOT Aviation Services Section Information

The aviation services section is under the Division of Air, Rail and Transit, within the South Dakota DOT. The captain involved in the accident was the section manager and chief pilot, and he performed scheduling, coordination and internal accounting for the section, in addition *to* his flying duties.

The section's primary function was **to** transport the Governor of South Dakota in his travels on state business. Transportation was provided for other personnel on state business after the Governor's needs were met. The Governor's requirements were relayed via internal electronic mail from his office to the captain, in itinerary format, indicating the Governor's first and last appointment at a destination. Communication between the captain and the Governor's staff resolved travel time and selected appropriate departure times.

The section occupied an office in the DOT building next to the **state** capitol building. A **hangar** at the Pierre Airport housed the section's airplanes, the mechanic's office, and the pilots' flight planning room. The planning **room** contained terminals for access to a commercial weather and flight planning service, Kavouras Weather System, and to the FAA-sponsored DUATS (direct user access terminal system) for weather, NOTAMs [Notice **to** Airmen], and flight plan filing. The pilots had access to a flight service station in the airport terminal building.

The section's full-time personnel were three pilots (including the manager), a mechanic, and a secretary. **Two** additional pilots were **under** contract to DOT as part-time first officers in the MU-2 when full-time pilots were not scheduled in both pilot seats. One **of** the part-time pilots **also** worked as a second mechanic when he was not flying.

The airplanes used were N86SD and a PA-34. The latter is a twin, piston-engine airplane with a capacity for six people, including the pilot. The full-time pilots routinely flew both airplanes. The section's mechanic, who holds an airline transport pilot certificate, has flown as first officer in N86SD on occasion.

A memorandum of November 25, 1987, from the South Dakota Secretary of Transportation established a policy that two-pilot flightcrews is required for passenger flights **in** the MU-2; the pilot-in-command (PIC) must have

completed formal training in the MU-2; and the second pilot must have completed a study of the airplane manual and a flight check by the chief pilot.

The pilots divided cockpit duties according to seat position. The PIC occupied the left seat and manipulated the flight controls while the second pilot was responsible for radio communications, systems operation, and the execution of checklists by the challenge-and-response method. The duties for the respective positions were delineated in an internal document entitled, "Co-Pilot Syllabus." When two pilots who qualified as PIC made a trip together, they alternated as PIC on successive legs, exchanging seats between landing and subsequent takeoff.

Pilots recorded flight time, passenger names with departmental affiliation, and fuel purchases on a form labeled, "Daily Flight Record and Load Manifest." The captain used the form to record airplane utilization and operating expenses. He allocated expenses to various state agencies based on the passenger miles flown by their personnel. The section did not maintain records of individual pilots' flight time. Pilots maintained personal flight logs and kept them at home or in their offices.

Maintenance discrepancies were handled by verbal briefing to the mechanic or by annotating the Daily Flight Record. The pilots interviewed described the airplane as well maintained and without recurring or deferred discrepancies.

1.17.1.1 Aviation Services Section Training

Each of the three full-time pilots had formal initial and interval refresher training as PIC in the MU-2. Their training was obtained at Right Safety International (FSI), Houston, Texas. The section's mechanic attended maintenance training on the airplane at FSI and at the engine manufacturer. FSI is the airframe manufacturer's designated training site for the model.

The accident pilots last attended training from December 14 through 16, 1992. Each pilot obtained recurrency checks as PIC that were conducted in a flight simulator. They attended initial training in model in 1983 and refresher training since that time, usually together at 6-month intervals. Both pilots had flight instruction in the accident airplane in 1983 that included emergency descents, engine failures in various flight regimes, and single-engine instrument approaches. Single-engine flight was simulated by reducing one engine to zero thrust. The same

abnormal or emergency procedures were covered in refresher training, either in classroom instruction or in the simulator.

The part-time pilots had not attended formal training in the MU-2. Their training consisted of an introduction to the airplane by the section's pilots or mechanic, a review of the airplane flight manual, and an indefinite number of instructional flights. Instruction in the airplane occurred when passengers were not aboard. Both contract pilots stated that they had not encountered or simulated single-engine flight in the airplane.

The Co-Pilot Syllabus described the division of labor in the cockpit but did not outline or quantify training. In interviews with section personnel and the part-time pilots, there was no account of a local (Pierre, South Dakota) examination or flight check.

1.17.2 Hartzell HC-B4 Propeller Description

1.17.2.1 General Description

The Hartzell HC-B4TN-SGL model propeller is a 4-bladed, single-action, hydraulically operated, constant speed propeller with full-feathering and reversing capabilities. Oil pressure from the primary propeller governor is used to move the propeller blades toward the low pitch position (low blade angle). Counterweights, mounted on the propeller blade clamp, and feathering springs direct the blades toward the high pitch position (high blade angle). The propeller is of all-metal construction. The propeller rotation is counterclockwise, aft looking forward. Very similar propellers are also manufactured in a 3-bladed and 5-bladed configuration.

The propeller hub is the central structural base of the propeller, as shown in figure 5. The hub has four arms that extend radially outward from the center of the hub. The hub also has a mounting flange for attaching the propeller to the engine. The hub is a machined forging made from 4340 steel, containing nickel, chromium, and molybdenum as alloying elements. Assembly of the propeller is started by inserting a machined steel pilot tube into a hole that is drilled radially inward from the outboard end of each arm. The pilot tubes are a larger diameter than the pilot tube bore in the hub arm. The larger diameter of the pilot tube is needed to obtain a specified interference fit between the tube and the hub arm upon assembly. Assembly of the tube is performed by room-temperature pressing the

tube into the hole to a specified depth. A propeller blade is then inserted onto a portion of the pilot tube that extends out of the hub arm. The inboard end of the blade is then clamped to the flange on the outboard end of the hub arm.

During operation, most of the bending loads on the blade are passed to the hub through the pilot tube. The centrifugal loads and some bending loads on the blade are passed to the hub through the clamp.

1.17.2.2 Normal Loads

During flight (*high* thrust conditions), the loads on each propeller blade can be divided into three types: radial outward loads from the centrifugal motion, loads in the direction opposite of rotation from drag, and loads in the forward direction from thrust. For the hub arms, the centrifugal loads dominate, resulting in tensile stresses throughout the shank portion of the hub arms where the fatigue fractures occurred. The thrust and drag loads on the blades introduce bending stresses into the hub arms. These bending loads would be expected to increase the tension in the aft and leading edge sides of the arms and to decrease the tension in the forward and trailing edge sides of the arms. During reverse thrust conditions, there is a load in the aft direction on the blade. This would result in an increase in the tension in the forward and leading edge sides of the hub arms, and a decrease in the tension in the aft and trailing edge sides of the hub arms.

In addition to the steady state loads described above, the propeller blades are also subject to a vibratory load referred to as the "P" factor. The frequency of the "P" factor loads is once per revolution of the propeller, and these loads arise from the fact that the plane of the propeller is usually slightly tilted to the incoming wind during flight. This tilt results in slightly different amounts of thrust for a given blade in different portions of the plane of revolution.

While the airplane is on the ground or taxiing, there is little or no thrust on the propeller blades, and the propeller is rotating slower than in flight. This results in reduced centrifugal loading of the hub arms and, usually, minimal vibratory loads because of the minimal thrust.

1.17.3 Certification of KC-B4 Propeller for MU-2B Application

The original models of the MU-2B airplane were assembled by Mitsubishi Heavy Industries, Ltd., in Japan and exported to the United States as essentially complete airplanes. The certification and issuance of a **Type Certificate** for these **models** was accomplished under the provisions of Civil Aviation Regulation (**CAR**) Part **10**, dated March 28, 1955. This regulation authorized the U.S. Federal Aviation Agency to accept the findings of compliance made by Japan's Civil **Airworthiness** Authority with requirements that provided an equivalent level of safety to the airworthiness requirements of U.S. CAR Part 3 and specified special conditions **that** applied at the time of certification. The Type Certificate **for the** original MU-2B was approved November 4, 1965. All subsequent models of the MU-2B that were approved under this Type Certificate were equipped with 3-bladed Hartzell HC-B3 propellers.

The **later** models of the **MU-2B**, including all **of** those with 4-bladed Hartzell **HC-B4** propellers, were assembled as complete airplanes in the United States. A **separate** Type Certificate was issued for these airplanes and the **certification** basis was **CAW** Part 3 plus special conditions. The applicable regulation pertaining to propeller vibration was **CAR 3.417**, which stated, in **part**:

In the case **of** propellers with metal blades or other highly stressed metal components, the magnitude of the critical vibration **stresses** under all normal conditions of operation shall be determined by actual measurements or by comparison with **similar** installations for which such measurements have been made. **The** vibration stresses thus determined **shall** not exceed values which have been demonstrated to be safe **for** continuous operation. Vibration tests may be waived and the propeller installation accepted on the basis of service experience, engine **or** ground tests which show adequate **margins of** safety, or other considerations which satisfactorily substantiate its safety in this respect.

The certification criteria for propeller vibration remains essentially unchanged today in the airworthiness requirements of **14 CFR 23.907**.

To comply with the airworthiness requirements, the **propeller manufacturer** must consider during design and subsequently demonstrate the

vibration characteristics of the propeller assembly to assure that resonant frequencies that can produce critical vibration stresses do not occur within the normal operating range for which the propeller is intended to be used. One of the known vibration modes that must be considered is that which can be experienced when a crosswind or tailwind component acts on the blades as they revolve during ground operations. The changes in the wind force on the propeller blades, because of the proximity to the airplane's wing, excite the blade vibration. In the case of 4-bladed propellers, pairs of opposite blades vibrate in phase with one pair vibrating forward while the other pair vibrates aft. Such vibration results in reverse bending stresses in the blade and hub arms with little or no relative motion or vibration of the mounting flange because the resulting motion of the blades is balanced on the propeller shaft. This is termed the "reactionless" mode of vibration and is particularly insidious because the pilot may be unaware of the propeller vibration. When in the reactionless mode condition, each blade and hub arm experiences two cycles of vibration for each revolution of the propeller.

During the certification of the Hartzell HC-B4 propeller installation on the MU-2B model airplanes, ground testing was accomplished to identify possible reactionless mode conditions. This was done by using another airplane to blow a quartering tailwind across the rear face of the propeller blades on an instrumented propeller assembly to attempt to excite the blades into the reactionless mode condition. Wind speeds of 20 to 25 knots were used to determine the stress levels and engine speed range at which the propeller reactionless mode occurred. The testing was accomplished by Hartzell Propeller and Mitsubishi personnel at the Mitsubishi factory in San Angelo, Texas, in 1976.

During these certification tests, Hartzell identified a reactionless mode of vibration with peak stresses occurring at a propeller speed of 1,079 RPM. The result of the investigation of vibratory stress levels of Hartzell model HC-B4 propeller mounted on the MU-2B airplane was described in a Hartzell engineering report dated August 21, 1976. The testing upon which this engineering report was based was accomplished using newly manufactured propeller blades. The Safety Board did not find evidence that tests were repeated using propeller blades altered to conform with the minimum dimensions specified in the repair limit criteria contained in the Propeller Maintenance Manual produced by Hartzell for the HC-B4 propeller. The report was approved by the FAA and was provided to Mitsubishi to support the certification of the aircraft. The report contained the restriction that "continuous operation on the ground below 1,145 RPM (72% of engine RPM) is prohibited."

By tailoring adjustments to the engine fuel control settings and propeller pitch stop limits, the minimum engine speed for the airplane with the power control and propeller conditioning levers at the ground idle position was limited to 1,145 RPM. Thus, operation at the reactionless mode speed of 1,079 RPM is avoided except for the momentary acceleration and deceleration encountered during engine start and shutdown.

In addition to those tests to determine the reactionless mode vibration characteristics, the airplane/propeller certification tests conducted in 1975 included flight tests to determine the stress levels for maneuvers usually performed by a normal category corporate use airplane. The tests included in-flight engine shutdown and startup, negative torque sensing procedures and feathering and unfeathering of the propeller. The airplane was flown at different weights for cruise and climb conditions that would normally be seen in service. The airplane propeller was also bested at high bank angles and yaw angles. Flight strain vibration data were measured. The testing indicated that there were no stresses in the propeller that would require restrictions or life limits on the propeller design installation.

The Type Certificate for the MU-2B-60 equipped with Hartzell HC-B4 propellers was approved on March 2, 1978.

1.17.4 Production History and Other Applications of HC-B4 Propellers

Hartzell has provided the Safety Board with the following information relative to the production of the HC-B3, 4 and 5 blade model propellers:

Production of the 3-blade hub began in 1963. The 4-blade propeller hub was certificated on April 27, 1971.

There have been 26,423 hubs produced for 3-bladed propellers, 5,212 units for 4-bladed propellers, and 1,114 units for 5-bladed propellers, for a total of 32,749 units.

On three occasions, Hartzell made changes in the manufacturing process of its steel propeller hubs. The first change occurred on January 27, 1981, when the heat treatment was changed from an austempering¹³ treatment designed to

¹³ An austempering heat treatment involves quenching the steel from an elevated temperature to an intermediate temperature of about 500° F to 750° F and holding to transform the steel to bainite.

produce a bainitic microstructure to a quenched and tempered treatment designed to produce a tempered martensitic microstructure. The second change occurred in December 1982. At this time, changes were made to the quenching and tempering processes. The third change occurred in April 1984. Prior to that date, final machining **of** the hub **and** burnishing **of** the pilot tube holes in the hub arms were performed **prior to heat** treatment. After that date, **the** pilot **tube** holes were final machined and burnished after the heat treatment.

Production **of** the 4-bladed propellers **is** as follows:

Initial production up to January 27, 1981, was 2,071 units.

Production **from** January 27, 1981, to December 13, 1982, was 752 units.

Production from December 13, 1982, to present was 2,389 units.

Hartzell HC-B4 model propellers are installed **on** the following airplanes:

<u>Model</u>	<u>Number of Airplanes</u>
Beech F90 King Air	237
Beech A100, A100A (U-21F King Air)	155
Beech B100 King Air	137
Beech 300, 300LW	243
Beech B300, B300C, Super King Air 350	95
Beech 1900, 1900C Airliner	245
deHavilland ST-27B Saunders	Unknown
Let L-410A Turbolet	Unknown
Casa C-212-CB, -CC, -CF	About 200
Dornier DO228-100, -101, 1200, -201, -202, -212	About 200
Fairchild SA226-T(B) Merlin IIIB	124
Mitsubishi MU-2B-26A, -36A, -4-, -60	289
Mitsubishi MU-2B-30 (STC)	Unknown
Shorts SC-7 series 3, variant 200	Unknown
Totals: Estimated	1,925 airplanes
Estimated	3,850 propellers

According to **data** provided by **Hartzell** for the **MU-2B** fleet equipped with 4-bladed propellers, approximately **30** percent of the fleet for which **data** are available [**66 out of** a population of **216** (estimated)] has accrued 4,000 or more **total** operating hours on the propellers.

1.175 Previous Hartzell Propeller Blade Failures

A review of Hartzell, Mitsubishi, and Garrett records, and FAA Service Difficulty Reports, revealed that Hartzell HC-B3T (3-bladed) and HC-B4T (4-bladed) propeller blades (as opposed to propeller hubs) had failed on 10 occasions prior to the N86SD accident. One failure occurred on a Dornier 228, three failures occurred on Swearingen Metro IIs, three failures occurred on Mitsubishi MU-2B-60s, and three failures occurred on other models of the MU-2B. Hartzell attributed the blade failures to corrosion.

1.17.6 Previous Failure of a Hartzell HC-B4 Propeller Hub

1.17.6.1 September 27, 1991, Accident

In an accident on September 27, 1991, in Utica, New York, another MU-2B-60 airplane experienced a fracture of one of the propeller hub arms on the right propeller, which was a Hartzell model HC-B4. In this accident, a right propeller hub failed and released one blade. This blade, or a piece of another damaged blade, pierced the fuselage. The engine mounts did not fail completely, and the engine remained aligned with the relative wind. The propeller autofeathered. According to the pilot, he could not arrest his descent after the hub failure and autonomous engine shutdown, and he was "just barely" able to reach the runway at Utica.

Metallurgical examination of the broken hub at the Safety Board's Materials Laboratory revealed that the fracture was the result of fatigue cracking that initiated from multiple initiation sites on the surface of the hole for a pilot tube. The longitudinal location of the origin area was in the same position as the Zwingle accident hub (near the inboard end of the pilot tube), but the circumferential location of the origin area was at the 2:00 position, approximately diametrically opposite from the origin area of the Zwingle accident hub. The origin area and the fatigue crack fracture surface was darkly discolored through to the outside surface of the hub. Spiral scratches, possibly created during burnishing of the pilot tube hole, were found on the surface of the hole in the vicinity of the origin area. The hub was

manufactured in 1977, and its microstructure was **found** to be a mixture of **bainite** and apparently **martensite**, similar to **the** microstructure on the separated Zwingle **accident** hub. Corrosion **pitting** was also found on the surface of the pilot **tube hole** in **the** hub **arm**. However, the fatigue initiation sites **could** not be **traced** to specific corrosion **pits**.

At the time of this failure the propeller hub had accrued a total operating time of 4,460 hours.

1.17.6.2 Resulting Safety Board Recommendations

The *Safety* Board issued *three* safety recommendations on **August 13**, 1992, after the HC-B4T propeller hub failure on the **MU-2B-60** on September 27, **1991**, in **Utica, New York**. The airplane was climbing through **19,000** feet when the pilot felt a **strong** vibration, followed **shortly by** a loud **bang**. After landing **safely**, it was discovered that one of four arms of the **propeller** hub for the **right** engine had separated, releasing a propeller blade in flight. Severe vibration resulted in **partial separation** of the right engine nacelle from the engine truss mounts. **The** airplane **had** accumulated 4,805 operating hours when the failure occurred. **The** failed propeller hub had accumulated 4,460 operating **hours** at that time. **The** three **safety** recommendations were addressed to the **FAA** and are as follows:

A-92-81

Develop, with the assistance of **Hartzell Propeller, Incorporated**, a nondestructive inspection technique capable of detecting **hub arm** cracks **stemming from** the inside diameter surface of the hub arm at the approximate location of **the** inserted end of the pilot **tubes** on Hartzell model **HC-B4** propeller hubs, and issue an airworthiness directive requiring that **HC-B4 hubs** with **3,000 hours** or more be inspected **using** this technique the **next** time the propeller assembly is overhauled for **any** reason, or **at** the next annual inspection (or equivalent), whichever is first.

A-92-82

Determine, based on the results of the Inspections requested in Safety Recommendation **A-92-81**, if the hub arms on Hartzell model **HC-B4** propeller hubs with **3,000 hours** or more **should** be

inspected at periodic intervals. If such inspections are warranted, issue an *airworthiness* directive, as appropriate, requiring periodic inspections.

A-92-83

Determine if Hartzell model HC-B3 and -B5 propeller hubs, based on **similarity** of design and fabrication processes with the HC-B4 propeller hub, should be inspected for cracking in the hub arms. If such inspections are warranted, issue an airworthiness directive, as appropriate, requiring periodic inspections.

Communications between the FAA and the Safety Board concerning these **safety** recommendations are contained in appendix C. Following the Zwingle accident, Hartzell attempted to develop an inspection method that would be capable of detecting cracks that initiate from the interior of the hub arm. No method studied was capable of detecting such cracks unless the pilot tubes were removed.

1.17.7 FAA Actions Following the Zwingle, Iowa, Accident

On April 28, 1993, the FAA issued AD 93-09-04 concerning Hartzell Model HC-B4TN-5 propellers installed on MU-2B-60 airplanes. The purpose of the AD was "to prevent fatigue cracks in propeller hub arm assemblies progressing to failure, resulting in departure of the hub arm and blade, and that may result in engine separation and subsequent loss of aircraft control..." It required that the propeller hubs on all MU-2B-60 airplanes be magnetically inspected with the pilot tubes removed. The AD required that the inspection be repeated at 600-hour intervals.

On June 10, 1993, the FAA issued AD 93-12-01. This AD extended the provisions of AD 93-09-04 to Hartzell model HC-B4TN-5 propellers installed on other MU-2B airplanes (the -26A, -36A, and -40A versions). (See appendix E for copies of these two ADs).

Hartzell has reported that as of October 13, 1993, a total of 373 hubs from MU-2B airplanes have been inspected per ADs 93-09-04 and 93-12-01. This number represents 79 percent of the U.S. fleet of hubs used on MU-2B series airplanes and includes nearly all of the hubs in service on MU-2B-60 airplanes.

1.17.8 Results of Postaccident Hub Inspections

As a result of compliance with AD 93-09-04, propeller hubs on MU-2B-60 airplanes were subjected to magnetic particle inspection (MPI) with the pilot tubes removed. During these inspections, another hub was found with a cracked arm. The propeller was delivered to the airplane manufacturer in 1979 and was overhauled in 1985. The operating time at this overhaul could not be determined. There were 4,121 hours accumulated since the 1985 overhaul. This propeller was received at Hartzell for a hub inspection with the latest style blades installed. It was reported that the blades from this hub were reinstalled on a new hub when the propeller was reassembled.

This new hub, Serial No. CD-989, was made prior to the heat treatment change in 1981. Both the circumferential and longitudinal locations of the crack were the same as the origin area of the fatigue crack on the hub from the Zwingle accident. This crack was broken open and found to be 0.48 inch wide circumferentially and 0.12 inch deep. The presence of surface discontinuities at the origin area of the crack could not be verified because the hole diameter surface had been machined to an approximate 0.017-inch larger diameter to facilitate the mandated inspection of the hub.

Following the Zwingle accident, Hartzell gathered information concerning the condition of the pilot tube hole surface on many other Hartzell 3-, 4-, and 5-bladed steel propeller hubs. Most of these hubs had corrosion damage, including some with severe corrosion pitting. Many of the hubs had scratches or machining marks of some type. During the postaccident-mandated inspections of 4-bladed hubs on MU-2B airplanes, two hubs had to be scrapped because they contained deep machining grooves in the pilot tube hole wall.

The metallographic examinations of the broken hub from the Zwingle accident, the broken hub from the Utica accident, the hub found to contain a crack, and the examination of three additional hubs, which were made using the same heat treatment process, indicate that the mixture of bainitic and martensitic microstructures is typical for hubs made using the austempering heat treatment. Hubs made using this pre-1981 heat treatment process are used on a wide variety of airplanes other than the MW-2B-60.

1.17.9 Postaccident Hub Tests - Vibration and Stress Survey

Following the Zwingle accident, Hartzell conducted ground and flight tests with an instrumented propeller hub, in an attempt to quantify more precisely the operating stresses in the propeller hub. Strain gauges were placed in various locations along the inside diameter surface of the pilot tube hole. The strain gauges could not be placed directly at the fracture origin location because of the presence of the press-fit pilot tube at this location. The closest strain gauges were just inboard of the inboard end of the pilot tube. Consequently, a finite element analysis model¹⁴ was used to project the stresses measured at the strain gauge locations to the plane of the fracture. The Hartzell analysis showed that the stress is concentrated in the area of fracture plane (near the inboard end of the pilot tube) but that the stress level is relatively small for all normal operating conditions. The testing also confirmed that the reactionless mode of vibration would normally occur below the minimum ground idle RPM of 72 percent of full RPM. The reactionless mode of propeller vibration was known to be excited by an aft quartering wind while the airplane was on the ground.

The postaccident testing that Hartzell performed indicated that the resonant frequency of the reactionless mode can increase to within the normal ground operating RPM range for the MU-2B when the propeller contains worn or repaired blades. Hartzell found that the blades from the hub involved in the Utica accident had been overhauled and that the tips of the blades were substantially thinner than new blades but within the repair manual limits for removal of material. Removal of material from the tips of the blades will cause the resonant frequency of the blades to increase, thereby causing the resonant frequency of the reactionless mode to increase. Hartzell produced four blades simulating the condition of the blades from the Utica propeller and used these blades in their postaccident testing. The testing showed that the resonant frequency of the reactionless mode using these blades increased to a point above 1,145 RPM, the minimum ground idle speed, thereby creating the possibility that the reactionless mode could occur during ground operations.

Two of the propeller blades that were replaced during the earlier AD-directed blade change were also tested by Hartzell. These tests revealed that the reactionless mode resonant frequency of the blades was also above the minimum

¹⁴ A finite element analysis is a computer model for analyzing the stress distribution in a component.

ground idle speed for the MU-2B. According to the propeller logbook, these blades were removed from the hub after 4,344 hours of operation.

Hartzell has generated a listing of the margin between the resonant frequency of the reactionless mode of vibration and the placarded RPM range for different combinations of Hartzell steel propeller hubs and airplane models. This listing shows that the MU-2B series airplane has the least margin (a difference of 66 RPM) of those listed.

The shape of propeller blades is controlled at regularly spaced blade stations. At each overhaul, the thickness and shape of the blade must conform to minimum requirements at these stations. The Hartzell testing demonstrated that an increase in the resonant frequency of the reactionless mode of vibration will occur when material is removed only from the tip portion of the blade. Therefore, a relatively large distance from the tip of the blade to the nearest blade station would allow a larger area from which material could be lost without causing the blade to be rejected when it is inspected during overhaul. Hartzell has also generated a listing of the spanwise length of the blade adjacent to the tip over which the blade contour is not controlled. This distance is greater for blades on the MU-213 series airplanes than for any other application listed, which allows for more margin of metal removal that can result in an increase in the resonant frequency of the reactionless mode to a point where it occurs during ground idle conditions.

The strain gauge measurements generated by Hartzell during its testing of the reactionless mode of vibration were projected to the plane of the fracture using the finite element analysis model. Hartzell indicated that the derived cyclic stress in 5- to 15-knot, 15- to 25-knot, 25- to 35-knot, and 35- to 45-knot quartering tail winds were +/-8,645, +/-10,830, +/-12,614, and +/-15,525 psi, respectively. The steady state stress was 14,350 psi in all wind conditions. Hartzell also indicated that wind conditions higher than 35 to 45 knots would cause the reactionless mode stresses to increase. In comparison, during normal takeoff and flight operations, the stresses derived by Hartzell from flight testing varied, depending on conditions, with the highest mean stress being takeoff rotation (21,600 psi +/- 3,295 psi) and the highest cyclic stress being at cruise (17,400 psi +/-4,931 psi). Unusual conditions in normal flight regimes were also derived and found to be 19,650 psi +/- 8,043 psi. Testing conditions did not involve turbulence or gusting winds that Hartzell believes will increase these stresses.

The steady state {mean} stresses derived from the reactionless mode testing was always less than that occurring under normal flight conditions. **This is** because of the minimal thrust loads on the blades and the fact that the RPM of ground idle is lower than that of normal flight. All stresses measured or analytically determined for normal operation and the reactionless mode were below those that would produce fatigue cracking in a hub that has normal fatigue properties for the material.

1.P7.10 Air Traffic Control

1.17.10.1 Procedures

Paragraph 10-1, d, FAA Air Traffic Control handbook 7110.65, states that "because of the infinite variety of possible emergency situations, specific procedures cannot be prescribed. However, when you believe an emergency exists or is imminent, select and pursue a course of action which appears to be most appropriate under the circumstances and which most nearly conforms to the instructions in this manual."

Paragraph 10-22, Emergency Airport Recommendation, states that weather conditions, among other items, should be considered "when recommending an emergency airport."

1.17.10.2 Small Airport Information Available to Controllers

The air traffic control sector in which the decompression occurred was called the Coton **High** sector. This sector controls airplanes at and above flight level 240. Small airports are not normally depicted on the radar map used for high sectors. However, the controller working the sector (manual) position reported that to assist the radar controller, she depressed the sector boundary button to bring up additional airports that are not normally displayed on the radar screen. CWI was then displayed, as well as DBQ and MLI. Additional information can be obtained on a specific airport by the controller by typing the letters "A" (meaning "airport information") into the computer, then placing the cursor over the airport symbol on the screen and pressing the "enter" key.

Information such as airport elevation, UNICOM frequency, pilot-controlled lighting capability, runway surface, longest runway, nearest navigation

aid, and primary navigation aid, appear on a **small** display adjacent to the radar screen. **This** additional available information was not brought up by **the** controller involved in this airborne emergency.

1.17.10.3 Air Traffic Controller Weather Retrieval Methodology

To obtain a specific weather sequence **report**, the radar controller **must** call **up** the sequence via a keyboard so that it is displayed on the CRD.¹⁵ Only one sequence at a **time** can be displayed. If the sequence report is updated **with** a new report, the updated **information is then** displayed, replacing the old information. If the **radar** controller receives another message (not necessarily **related to** weather) on the radar CRD, the message replaces the sequence **report** OR the CRD screen.

The sector (manual) controller **also has** a CRD. At his position, the sector controller can also call up only one weather sequence report **at a time**. However, **this** sequence report will **remain** in a dedicated position on the display screen and will **not** be displaced by another message until a request **is** made to display another weather sequence **report**. If **the** sequence report is updated, **this** information **is** automatically displayed.

The only other means **to** display a sequence report at a radar or sector controller position is for a controller to **request** that a **flight progress** strip be **printed**, to place that **strip** in a strip holder, and to put it in a strip bay. Only one sequence report can be displayed on **an** individual strip. However, several strips could be displayed, each with a separate weather sequence report on **it**. Periodic requests would have to be made to keep the **information** current, since there **is** no automatic update.

The supervisor **of** each area in the ARTCC also **has** a computer terminal (part of the Meteorological Weather Processor) available that is capable **of** displaying weather sequence reports. The computer **is not** located near individual sectors **for** the immediate use **by** controllers. **The** Center Weather Service Unit meteorologist was also available in the **radar** control room **to** assist in weather matters. His equipment **is** also **not** located near **the** individual sector controller areas.

¹⁵CRDs are cathode ray tubes located on the display consoles that provide controllers with various messages concerning *air* traffic matters. Incoming information can either be requested by the controllers or will appear on the Screen automatically. The main CRD is located between the strip bays in front of the manual controller.

2. ANALYSIS

2.1 General

The Safety Board determined that the airplane was **being** maintained and flown by State of South Dakota personnel in accordance with procedures that were applicable at **the time** of *the* accident. No structural anomalies or systems malfunctions were discovered in the wreckage (other than the **missing** propeller blade and damaged **left** engine mount), and no evidence of **fire in flight** was found. The **Safety Board** could **not** determine whether pieces of propeller blade injured anyone aboard N86SD. Although the flightcrew's specific radio call for an ambulance may have meant that an injury had occurred, the call could have **also been** because of the decompression, or because the flightcrew expected difficulties during landing. **Lastly**, the severe weather in the Illinois/Iowa area, causing the flight plan deviations of N86SD, had no effect on the accident sequence of events, although the **low** ceiling in the DBQ area did play a role in the outcome of the accident.

Following the **propeller** blade loss, the combination of the loss of engine power, the increased **drag from external** sheet metal damage, and the increased drag from the canted engine nacelle and propeller blades caused airplane **control** difficulties **that** prevented the flightcrew from arresting the descent. The **catastrophic** consequences of the accident were the result of the controlled descent of the airplane in low visibility conditions that eventually precluded an evasive maneuver to avoid collision with **the silo**.

2.2 Analysis of the Hub Arm

The Safety Board determined that the separation of one of the four propeller hub arms of the left propeller was the result of fatigue cracking that initiated **from** multiple initiation sites on the inside diameter surface **of the hole** for a pilot tube. In attempting to determine the cause of the cracking **on** the left propeller hub from **the Zwingle** accident, *the* Safety Board **took** into consideration information **obtained** on the broken hub from the Utica, New York, accident on September 27, 1991, and the hub **that** was found to contain a crack during the inspections mandated **after** the Zwingle accident. In addition, the Safety Board **gathered** information concerning the operating stresses on the hub and its vibration characteristics.

The broken hub involved in the Utica accident was also from an **MU-2B-60** airplane. **The** cracking on **this** hub was **similar** to the hub involved in the Zwingle accident because it initiated from multiple initiation sites on the inside diameter surface of the hole for a pilot **tube**. **Although** the longitudinal location of the origin area was in the same position **as** the Zwingle hub (near the inboard end of the pilot **tube**), the circumferential location of the origin area **of** the cracking in the Utica hub was **at** the 2:00 position, approximately diametrically opposite the origin area on the **Zwingle** hub.

The cracked hub found during the mandated inspections was also **from** an **MU-2B-60** airplane. The circumferential and longitudinal locations **of the** crack were the same **as** the origin **area** of the fatigue crack **on** the hub from the Zwingle accident.

The Safety Board believes that the discolored portions of the fatigue cracks in the Utica and Zwingle hubs are regions where the crack **is** growing slowly, allowing **time** for corrosion to occur. Beyond the discolored portions, the cracks were **growing** fast enough that corrosion did not have **sufficient** time **to** discolor these **portions** of the fracture. It is possible that propagation was occurring with each revolution **of** the propeller in the areas beyond the discolored portions **of** the fractures. The propagations would be attributable to the cyclic loads that occur as a **result** of blade angle-of-attack changes as the blade rotates (P-factor).

The investigation **into** the cause of the fatigue crack in the hub from the **left** propeller **from the** Zwingle accident uncovered several mechanical and metallurgical factors **that** can contribute to the initiation of the cracking. These factors included the microstructure of the hub, scratches or machining **marks** at the **origin** area, decarburization of the surface from which the fatigue cracking initiated, and extensive corrosion in the bore of the hub. Because of these factors, the Safety Board believes that **the** hub was sensitive to crack **initiation**. Once a crack initiates, it is very likely that it **will** propagate to a critical **size** unless detected during inspection.

The core hardness of the hub was slightly lower than the specified hardness range. **This** reduced hardness would have only a minor effect on the overall strength of the part. Because the core hardness is **not** representative of the **surface** hardness, it is not a factor **in** the initiation of the fatigue cracking.

The Safety Board also learned that the reactionless mode of vibration may have subjected the hub to higher-than-expected stresses. The factors that may have contributed to the initiation of the cracking are discussed in the following sections.

2.2.1 Surface Discontinuities and Metallurgical Factors

The Safety Board determined that the broken hubs from the Zwingle and Utica accidents had surface discontinuities (scratches or machining marks) on the pilot tube hole surface in the vicinity of the origin areas. Examinations of other Hartzell steel propeller hubs indicated that these scratches or machining marks may be typical of a large number of hubs. The Safety Board believes that these scratches and machining marks can act as stress raisers and can cause fatigue cracking to initiate at levels of loading less than theoretical for the material.

The mixed microstructure (bainite and martensite) found on hubs made prior to the heat treatment change in 1981 (including the two broken and one cracked hubs) would be expected to have lower fatigue properties than either a pure bainitic or martensitic microstructure. The mixed microstructure indicates that the bainitic transformation was not complete on heat treatment to produce a uniform homogeneous structure. After austenitizing at 1,550 degrees F, the part is to be quenched to 690 degrees F, which is above the martensitic transformation temperature. The part is supposed to be held at this temperature for a sufficient time until austenite transforms completely to bainite. However, if not held in the quench media for a long enough period, some retained austenite will remain in the structure. This retained austenite can then transform to martensite when the part is cooling to room temperature after the 690-degree F quench. Martensite results in a volume expansion of the material that can produce residual stresses in the part. Such residual stresses can be tensile at the surface contributing to premature fatigue initiation.

Because the size and relative magnitude of what appeared to be martensitic colonies in the microstructure were approximately the same as the size and magnitude of the intergranular features on the fracture surface, the Safety Board believes that these features are related. The presence of sporadic regions containing intergranular features in a fatigue fracture of 4340 steel is unusual, and the Safety Board believes that this may be a sign of embrittled or weakened material at grain boundaries. The extensive preaccident corrosion and rubbing on the fracture

prevented a determination of the presence of similar intergranular features at the origin of the fatigue cracking.

The Safety Board also found decarburization along the pilot tube hole that would reduce the fatigue properties of the steel. Decarburization occurs during heat treatment when the surface of the part is exposed to an oxidizing atmosphere at high temperatures. Carbon is partially depleted at the surface as it combines with the oxygen. The decarburized layer, being much softer and weaker than the underlying material, is more susceptible to fatigue crack initiation.

The manufacturing process that was used prior to 1984 called for final machining the pilot tube bore prior to heat treatment. Therefore, any decarburization layer that was produced during heat treatment of a hub made before 1984 would not be removed by subsequent machining. Final machining is preferred after heat treatment since correctly performed machining will not only remove decarburization but will also introduce a slight cold work layer resulting in residual compressive stresses at the surface that will increase the fatigue resistance of the material.

Also of concern was the applied stress and damage that results from the assembly of the press-fit pilot tubes into the bore of the hub. If the hole or pilot tube is not sufficiently round, interference between these members will not be uniform, resulting in local stress concentrations and/or damage of the hub at the interface with the pilot tube. The interference fit produces hoop stress around the circumference of the hub arm. These stresses also occur to a lesser degree in the longitudinal direction, corresponding to the direction of stresses that initiated the cracking found on the hubs.

Corrosion in the area between the inboard end of the pilot tube and hub hole wall surface can also increase the local interference and local stresses. Corrosion products (iron oxide) are of a larger volume than the steel (which is being oxidized); therefore, additional pressures can be introduced between the pilot tube and hub due to wedging of these corrosion products between these members as the steel corrodes.

Although corrosion pitting could not be directly linked to the fatigue cracking, corrosion in any form can be detrimental, and pitting does not have to occur to produce a reduction in fatigue properties. Corrosion can produce localized

fracturing in areas prone to grain boundary separation, such as along prior austenitic grain boundaries of localized pockets of martensitic transformation.

The Safety Board believes that the hubs manufactured where the finished machining operation was done prior to heat treatment (prior to **1983**) are the most at risk for lower fatigue properties. **This** is because, besides corrosion, the decarburization and associated residual stress are the most influential in affecting the fatigue resistance of the material.

The Safety Board concludes that the fatigue properties of the hub were substantially reduced by a combination of factors and that cracking would not have initiated if the properties had not been reduced. The Safety Board examined two possibilities for the source of stresses that caused crack initiation: normal operating stresses, and stresses associated with the reactionless mode of vibration.

2.2.2 Normal Operating Stresses as a Source of Crack Initiation

Hartzell has indicated that the normal flight loads on the MU-2B-60 induce stresses on the propeller hub that are some of the highest of any of the Hartzell steel hubs. Therefore, hub arm failures on the MU-2B-60 could be consistent with hub cracking as a result of degraded fatigue properties and normal operating stresses.

The postaccident testing conducted by Hartzell demonstrated that the cyclic component of the stresses in the origin area of the Utica hub are about the same as those for the origin area for the Zwingle hub for both the reactionless mode of vibration and during normal flight. Because the cyclic component has a much greater effect on fatigue crack initiation than does the steady state portion of the stress, the location of the origin areas on the two broken hubs could be consistent with stresses from either the reactionless mode or the normal flight.

For the above reasons, the Safety Board cannot rule out that the normal operating stresses on the MU-2B-60 are sufficient, given the degraded fatigue properties, to cause fatigue cracking. **Because** of this possibility, the Safety Board believes that the FAA should identify Hartzell steel propeller hubs on other airplanes that have high stresses during flight and should conduct a designated safety inspection for cracks in the pilot tube hole of the hub arm on those hubs that have high amounts of operating time and that were manufactured with pilot tube holes machined prior to heat treatment. The Safety Board also believes that the

reduced fatigue properties are present on the 3- and 5-bladed Hartzell hubs, and that similar actions should also be considered for hubs with similar stress levels.

2.2.3 Reactionless Mode as a Source of Stresses

Despite the precautions that are taken to avoid operating the propeller in an RPM range that matches the resonant frequency of the reactionless mode of vibration, the postaccident testing that Hartzell performed indicated that the resonant frequency of the reactionless mode can increase to within the normal ground operating RPM range for the MU-28 when the propeller contains worn or repaired blades. This was demonstrated using a propeller with blades similar to those from the hub involved in the Utica accident, and with propeller blades installed on the Zwingle hub prior to the AD-mandated propeller blade change.

The Safety Board found that two factors must interact in order for the reactionless mode of vibration to occur at or above the ground idle speed of the engine. First, there must be a relatively small difference between the resonant frequency of the propeller with new blades and the minimum ground idle speed of the engine. Second, material must be lost from only the tip portion of the blade.

An examination of the margin between the resonant frequency of the reactionless mode of vibration and the placarded RPM range for different combinations of Hartzell steel propeller hubs and airplane models shows that the MU-2B series airplane has the least margin (a difference of 66 RPM) between the ground operating range and the resonant frequency of all applications of the 4-bladed propeller.

The shape of propeller blades is controlled at regularly spaced blade stations. At each overhaul, the thickness and shape of the blade must conform to minimum requirements at these stations. A relatively large distance from the tip of the blade to the nearest blade station would allow a larger area from which material could be lost without causing the blade to be rejected when inspected during overhaul. Hartzell has also generated a listing of the spanwise length of the blade adjacent to the tip over which the blade contour is not controlled. This distance is greater for blades on the MU-2B series airplanes than for any other application listed.

Hartzell has therefore demonstrated that both of the propeller conditions needed to allow operation in an RPM range corresponding to the

resonant frequency of the reactionless mode of vibration are more likely to occur on the MU-2B than on any other application. The FAA has indicated that a study of the propensity of other propeller/airframe combinations to experience the reactionless mode of vibration is being conducted and that appropriate action will be taken to ensure that aircraft operations are kept out of this mode of vibration as much as possible. The Safety Board supports this effort and urges the FAA to complete this study and to issue appropriate airworthiness directives.

The Safety Board found substantial circumstantial evidence that the reactionless mode of vibration contributed to the initiation of the fatigue cracking on the Zwingle hub. As the reactionless mode occurs, the steady state and cyclic portions of the stress are nearly the same at the locations of the origin areas for the Zwingle and Utica hubs. Therefore, cracking that initiates from the reactionless mode of vibration could initiate on either side of the hub. The Safety Board believes that the location of the origin area on the Utica hub is more consistent with initiation from reactionless mode stresses than from stresses associated with normal operation. This is because the steady state portion of the stress also contributes to crack initiation, and, during normal operation, these stresses are greater in the portion of the hub arm opposite the Utica initiation area. Also, the Hartzell postaccident testing using blades similar to those from the Utica hub demonstrated that the reactionless mode of vibration could have occurred during ground operations of the Utica airplane when the propeller vibration mode was excited by exposure of the airplane to a tailwind while operating at a critical RPM.

More convincing evidence of the reactionless mode was found on the Zwingle hub at the end of the primary discolored zone emanating from the origin area. In this area, the already established crack front did not continue to propagate in its established shape and coloration. Instead, there appeared to be two separate cracks initiating from each side of the crack tip with the initial crack propagation relatively clean for some distance away from the discolored zone. Crack reinitiation from an already large, established crack front, such as that found in the initial discolored zone, is not typical and signifies a change in the stress state to a much lower cyclic stress.

Also, the location of the reinitiations on each side of the crack front indicates bending stresses resulting from different blade loading than that which initiated the origin of the discolored zone. Furthermore, under normal operating cyclic stress, the estimated crack initiation and propagation from a crack of 0.2 inch deep to the terminus of the fatigue region would be in the neighborhood of a few

hundred hours of flight operation. The only event that occurred within **this** time frame was **the** change in propeller blades on April 30, 1992, approximately 239 **flight** hours prior to the accident. The previous blades removed were **thinned** at the blade tips, resulting in a reactionless mode at or above ground **idle** operation. Therefore, the initial discolored zone is more representative **of** a higher cyclic **stress** state, such **as** that which can occur during the reactionless mode under high *aft* quartering winds. **The** reinitiation and propagation from this discolored zone **are** most consistent with lower cyclic **stress** from normal operation of the propeller.

In comparison, the Utica hub displayed discoloration from the origin area well through the hub arm thickness with no signs of reinitiation from an established crack front. The extent of discoloration may be representative of the reactionless mode occurring throughout the majority of the propagation of the fatigue cracking. At the time of **the** Utica accident, the blades were found in a configuration that would allow the reactionless mode to occur at or above ground idle.

Information from Hartzell has also shown that the MU-2B series airplanes are the most susceptible to having the reactionless mode of vibration during ground operations. The Safety Board also believes that the stresses associated with the reactionless mode will be greater than those measured (or derived) when the wind is greater **than 35 to 45** knots. The Safety Board also notes that the derived stresses associated with the reactionless mode are based on limited data and that there are numerous variables, such as blade clamping and bearing assembly tolerances and the amount of interference **fit** between **the** pilot tube and hub arm, that could affect the level of **stress**. Therefore, the cyclic portion **of** the stresses associated with the reactionless mode could be greater than any of the stresses from in-flight conditions. Increased cyclic stresses would increase the probability of fatigue crack initiation. Based on the stress levels associated with the reactionless mode and the propensity of the MU-2B airplanes to experience the reactionless mode at **or** above the ground idle **RPM**, the Safety Board concludes that **the** fatigue fracture of the hub is more likely to have initiated as a result of increased cyclic **stresses** produced during the reactionless mode **of** vibration, in combination with the substantially reduced fatigue properties of the hub material.

The Safety Board further concludes that the precautions taken during **the** initial certification that were intended to minimize **the** exposure of propellers **on** MU-2B airplanes to the reactionless mode **of** vibration were inadequate. Specifically, the Safety Board found no evidence that **Hartzell** conducted **or** the

FAA required or Mitsubishi requested any additional vibration survey tests using propeller assemblies having blades dimensionally conforming to the repair manual **limits** during the certification demonstration of compliance to propeller vibration requirements **in** 1976. **Thus**, the identification of engine speed at which the reactionless mode could occur was only applicable to propeller assemblies having new blades and the **full** engine speed range at which 2 reactionless mode condition could be experienced during the service of the airplane was not evaluated by tests. The Safety Board believes that the potential increase in the reactionless mode frequency for propeller blades of reduced mass should have been apparent to engineering personnel and that they should have required additional tests in order to **ensure** that the propeller operating limits and engine speed restrictions cited in the August 21, 1976, propeller vibration and stress survey report were adequate to prevent operation at the highest possible reactionless mode frequency. The Safety Board believes that the minimum ground idle RPM speed of the HC-B4 propeller on the **MU-2B** airplane needs to be increased to provide a greater margin between the resonant frequency of the reactionless mode and the ground idle speed. In addition, the distance between the tip of the HC-B4 propeller blades and the closest blade station needs **to** be substantially reduced, in order to reduce the uncontrolled area from which material can be lost, thereby minimizing the engine speed range in which the resonant frequency of the reactionless mode can occur.

The Safety Board is concerned that hubs on airplanes besides the MU-2 may have also been subjected to increased stress due to the reactionless mode of vibration in the normal operating range. Therefore, the Safety Board believes that the **FAA** should identify those airplanes that can, through a combination of the resonant **RPM**, the ground idle RPM range, and repair limits at the blade **tip**, produce **the** reactionless mode in the normal operating range. For these airplanes containing Hartzell hubs at risk for reduced fatigue properties (manufactured prior to April 1984), the **FAA** should require inspection for cracks in the pilot tube hole.

The Safety Board has been advised by the **FAA** that all of the 4-bladed hubs **delivered** by **Hartzell** for installation on MU-2 airplanes have been identified by serial number. However, the **FAA** has not yet been able to verify whether any **of** these hubs have been operated on MU-2 airplanes and subsequently installed on other model airplanes. The potential exists for damage induced during operation on the **MU-2 to** lead to failure on the other airplanes from normal operating loads. Therefore, the Safety Board urges the **FAA** to immediately determine the whereabouts **of** all 4-bladed Hartzell propeller hubs that have been installed at any

time on MU-2 airplanes, and require immediate inspections for potential fatigue damage in the hubs.

2.2.4 Analysis of Corrective Actions

Prior to the 1991 Utica accident, the **Hartzell** steel propeller hubs had an excellent service history and had no reported failures. Hartzell began manufacturing steel hubs in 1963, and more than 32,000 hubs, with millions of accumulated flight hours, have been produced.

The metallurgical examination of the hub from the Utica accident revealed that a fatigue crack initiated from the inside diameter of the hub arm and propagated outward. For this reason, visual or other nondestructive inspections of the outside surface of the hub would not be effective in detecting similar cracks. This finding prompted the Safety Board to issue Safety Recommendation A-92-81 on August 13, 1992. This recommendation urged the FAA to develop, with Hartzell's assistance, an inspection method capable of detecting hub cracks stemming from the inside surface of the hub arms. The Safety Board recognized that removal of the pilot tubes to more easily inspect the inside of the hub arms could create undetected damage and may have been unnecessarily expensive. prior to the Zwingle accident, the FAA had initiated no action in this regard, citing the long history of operation with the Utica fracture being the only separation of a Hartzell steel propeller hub. The Safety Board believes that the FAA could have taken more positive and timely action in response to Safety Recommendation A-92-81. See appendix C concerning FAA and Safety Board correspondence on this matter.

The Zwingle accident prompted the FAA, together with Hartzell, to initiate a program to develop an inspection method that would satisfy Safety Recommendation A-92-81. Hartzell has reported that several nondestructive inspection methods were studied. The only possible method was determined to be ultrasonic inspection. However, it was found that the inboard end of the pilot tube reflected the ultrasonic beam, making it impossible to distinguish between ultrasonic beam reflections from possible cracks and beam reflections from the end of the pilot tube. It therefore appears that currently available nondestructive inspection methods are incapable of detecting cracks initiating from the inside diameter surface of the hub arms when the pilot tubes are installed.

Because the Zwingle accident demonstrated that the **Utica** failure could no longer be considered unique, the FAA issued AD 93-09-04, on April 28, 1993, and AD 93-12-04, on June 10, 1993, requiring that all Hartzell HC-B4TN propeller hubs in service on MU-2B airplanes be inspected for cracks after removal of the pilot tubes. The ADs also require repeated inspections at an interval not to exceed 600 hours. Because of the potential risks from damage created by the removal and insertion of the pilot tubes during the inspection program, the FAA has authorized only Hartzell to perform the inspections. The Safety Board recognizes that the mandated inspection program is difficult and expensive and that it is therefore not a practical solution for assuring the integrity of Hartzell propeller hubs installed on airplanes other than the MU-2B series; nor is it a practical long-term repetitive inspection program for the **MU-2B** propeller assemblies.

2.3 Pilot Actions

ATC radar data suggest that once the airplane had descended to about 9,000 feet, the pilot tried to level off and maintain altitude until the airplane was established on the ILS to runway 31 at **DBQ**. However, the descent rate was not arrested but was reduced to about 900 fpm. The airplane was well below the glideslope and radar data show that the airplane never converged toward the glideslope except for one brief moment when the airplane was intercepting the localizer. In addition, the pilot made several statements to the effect that he could not hold altitude. The descent then continued, although at a slightly reduced rate, until the crash. The pilot confirmed that he was intercepting the localizer course, but he soon deviated 30 degrees to the left of the localizer course.

The Safety Board does not believe that the flightcrew deliberately attempted to fly below the 200- to 300-foot ceiling in the Dubuque local area to attempt to locate **DBQ**. Their level of training, their overall experience and experience in the MU-2 almost certainly precluded this possibility. In addition, and most importantly, they were aware of the low ceiling at Dubuque, and were undoubtedly aware of the inadvisability of low level flight over unfamiliar terrain. Therefore, the Safety Board analyzed why the flightcrew could not maintain level flight and attempted to determine the effects of the damage on climb capability and controllability.

2.3.1 Effects of Damage on Drag and Rate of Climb

The Safety Board believes that at the **time** of the crash into the silo, the engine was displaced downward about 30 degrees. This is based **on** the leading edge gouges on the L-2 propeller blade, the scrapes emanating from those gouges, **and** eyewitness accounts. In addition, the Safety Board believes that the engine **mounts** were totally separated prior to contact with the silo, and, at one **point**, the engine had been displaced inboard about 30 degrees. This conclusion **is** based on the damage found at the inboard engine mount/wing leading edge, zinc chromate found on two blade tips, **and** the known decompression of the cabin.

The Safety Board estimated that the 30-degree downward droop of the engine would increase the frontal area by 5.4 square feet. This assumed that the engine **was** pinned about 6 feet *aft* of the front of the nacelle and the nacelle was about 1.8 feet wide. The coefficient of drag (Cd) would have been about **1.5** due to the jagged edges of the disrupted cowl. The increase in the airplane's Cd attributed to the displaced engine **and** jagged cowl was **0.0455** (8.1 square feet/178 square feet).

Single engine performance data were based on the assumption **that** the propeller of the failed engine was feathered, the airplane was properly **trimmed** and that no other damage was present. Mitsubishi Heavy Industries (MHI) data showed that at a speed of 160 KCAS¹⁶ and 11,500 pounds, the single engine rate of climb with no damage and a feathered propeller would have been about **450 fpm up**. At these conditions, the Cd would have been about 0.063. The engine displacement would have increased the drag by about **72 percent** (**0.0455 + 0.063**) to 0.109. At 160 KCAS, the rate of climb would have been reduced from 450 fpm up to 534 **fpm** down. Additional cowling or fairing damage would have increased the aerodynamic drag. Each square foot increase in the flat plate frontal area would have increased the rate **of** descent an additional **156 fpm**.

At **175 KCAS**, the damage would have changed the rate **of** climb from **340 fpm** up to **948 fpm** down. Each 1 square foot increase in the frontal area would have increased the rate of descent by **203 fpm**. At 190 KCAS, the rate of climb would have changed from 150 fpm up to 1,504 down. Each drag increment

¹⁶Knots calibrated airspeed. KCAS is KIAS (knots indicated airspeed) corrected for airspeed indicator system errors.

equivalent to 1 square foot of increase in frontal area would have increased the rate of descent by **261** fpm.

The investigation disclosed that both airspeed indicators were at 190 KCAS after the **crash**. If the airplane were at 190 KIAS, the identified damage would have resulted in a **1,500 fpm** rate of descent, which was clearly not consistent with radar **data**. Also, witness reports indicate that for the last **4** miles, the airplane only **lost** several hundred feet resulting in a calculated rate of descent **of** about **200** fpm. Any damage greater than that equivalent to **1.3** square feet of frontal area would have resulted in greater than a **200 fpm** rate of descent at 190 KIAS. The damage identified by the Safety Board was more than **4** times greater than the **1.3 square** feet. The Safety Board concludes that the indicators were probably reading accurately; however, they probably did not reflect the actual airspeed at impact. The discrepancy between the actual airspeed and the instrument readings most likely resulted from disrupted airflow around the static **pressure ports**, either as a result **of** sideslip angles, engine cowl displacement, or both.

Based on the known damage, the 700 to 900 **fpm** rate of descent, and ground speeds derived from radar **data**, the Safety Board concludes that the airplane speed was between **150** and **175 KIAS**. If the damage were greater than estimated, the **speed** was most likely in the lower portion **of** this range.

2.3.2 Effects of Damage on Lateral Control

Damage to the nacelle would have resulted in a **loss** of lift, which, in **turn**, would induce a rolling moment that would **require** additional wheel deflections to maintain control of the airplane. **MHI** data show that single engine operation without nacelle damage required the spoilers **to** produce a coefficient of lift (Cl) **of** **.018** for **160 KCAS** and **.025** for **150 KCAS**. The damage **to** the nacelle would have raised the required Cl to **.029** for **160 KCAS** and **.037** for **150 KCAS**. With damage, **43** degrees (**54**percent) of wheel deflection would have been required at **160 KCAS** and **57** degrees (**72** percent) at **150 KCAS**. One hundred percent of wheel deflection would have been required at around **140 KCAS**. In addition, **MHI data** shows that approximately 50 percent rudder deflection would have been required at speeds between **150** and **160 KCAS**. Slowing to about **140 KCAS** would have required about **100** percent **of** rudder deflection.

The pilot would have found that slowing to **160 KCAS** would require **50** percent of both rudder and wheel deflection to keep the wings level or **banked**

into ~~the~~ good engine. Slowing to 150 **KCAS** would have required about 72 **percent** **wheel** deflection. Slowing further could have resulted in momentary loss of control until **speed** increased **or** power was decreased on the operating engine.

The slight increase in indicated altitude shown **on** radar data at ~~the~~ time ~~the~~ localizer **was** being intercepted could have indicated a **climb** that **would** be accompanied by a **loss** of speed **or** an increase in sideslip angle, either **of** which could have resulted in the temporary **loss of** lateral control.

2.3.3 Pilot Decisions on Flying the Airplane

The Safety Board examined the appropriateness of the **pilots'** decisions. **The** Board noted **that** the pilots initiated an emergency descent and descended down to and through 9,000 feet in a very rapid manner very likely **because** of ~~the~~ **cabin** depressurization. Had they attempted to arrest the descent at 12,000 feet, for example, and turned toward DBQ at the first instruction for a northerly turn from **ATC**, they **might** have had sufficient range to reach **DBQ**. In addition, had the crew stated the **true** seriousness of their situation to Coton High controllers, the controllers might have been more prone to search for a more suitable diversion airport.

The Board notes **that** the airplane was flying in IMC and **was** probably experiencing significant buffeting. Understandably, the pilot had received no **training for** the combination of circumstances that he faced. This combination included an engine failure, a displaced engine, cowl damage, unusually large control inputs, **an** unchecked descent, and **only** flight instruments for reference.

Immediately after the engine failure, the pilot initiated **an** emergency descent. **An** emergency descent would have required lower power settings for the operating engine, less wheel and rudder deflections to maintain control, and would have been conducted at higher airspeeds. Until the moment that the pilot attempted to **arrest** the rate of descent, he would have been unaware of potential control problems.

Once the pilot determined that he could not appreciably arrest the rate of descent by slowing down, but could gain a significant **margin** in available flight controls by flying faster, he probably chose to maintain a **higher** airspeed and more control **of** the airplane, thus accepting a higher descent rate.

The Safety Board notes that during the September 17, 1991, Utica, New York, incident, the pilot stated that he could not **maintain** level flight, even **though his** airplane sustained **less** aerodynamic damage than did **N86SD**.

The Safety Board concludes that the pilot acted in a reasonable manner in continuing the **high** rate of descent **to** lower **altitudes** and that once he was at lower altitudes, he continued to fly at higher airspeeds and rates of descent **to gain** more aerodynamic control.

2.4 Air Traffic Control Actions

Following the **loss of** the propeller blade and the decompression, the **flightcrew** requested from the Chicago ARTCC controller vectors to the "closest airport we can get to..." at 1540:46. Four seconds later, the controller transmitted that **DBQ** was at the airplane's 2:00 position and 25 miles away. **DSQ** was actually about **37 miles** from the airplane.¹⁷ At that time, the airplane was within 2 miles of being equidistant **from** **MLI** and **DBQ** and only about 9 miles from **CWI**. **The DBQ** and **CWI local** areas were experiencing **IFR** weather conditions, and the **MLI local** area was experiencing **VFR** weather conditions.

Immediately after the decompression, as **N86SD** progressed westward and descended, **its** relationship to **DBQ** and **MLI** remained about the same, while the distance from **CWI** increased. At 1542:15, the airplane was directed to turn to a heading of 330 degrees, but it did not do so. The nearly equidistant relationship from **DBQ** and **MLI** continued until the low altitude sector radar controller assigned the airplane the heading of 360 degrees. at 1543:45. After that, the distance from the airplane to **DBQ** decreased, while the distances **from** **CWI** and **MLI** increased, as the airplane descended to the north.

The Safety Board believes that **N86SD** would have broken out of the overcast at a higher altitude if it was on a course toward **MLI**, rather than **DBQ**, although **N86SD** was **not** offered this option by the controllers. This would have given the pilot more time to select a flat, open area on the ground to crash land the airplane, and the probability of flightcrew and occupant survival would have been greatly increased.

¹⁷ Air traffic control personnel stated that the inaccuracy of the radar presentation (at the radar range setting customarily used) accounted for this 12-mile error.

Following the propeller hub failure, the airplane probably had sufficient altitude to attempt an ILS approach and landing at CWI, although the flight was not offered this option by air traffic control. The difficulty of the approach would have been compounded by the low 400-foot ceiling. Also, the flightcrew would have had to fly some distance southwest of the airport to align the airplane for an approach to runway 03, which was the runway with the ILS approach.

Additionally, the center radar controller did not have readily available weather information for CWI to issue to the flight. Weather information for CWI was generated by AWOS, which is not available via the CRD screen used by the controllers. The controller would have had to either contact the Center Weather Service Unit or Quad City approach control to obtain the latest CWI observation. This process would have taken at least 1 minute or longer.

The reason the controllers said that they selected DBQ as the landing airport for N86SD, rather than MLI or CWI, was that they perceived that it was the closest suitable airport to the airplane when the emergency situation was announced. Of the two airports that they considered sending the flight to, DBQ was closer by about 2 miles. Acting upon the information they possessed at the time, they probably believed that they were complying specifically to the pilot's request. The fact that they were only aware of a decompression aboard the airplane (with no other complicating factors) at that juncture, and the fact that they knew the flightcrew was qualified to fly into IFR conditions might have also entered into their decision making process. In addition, they believed that DBQ possessed adequate emergency response equipment.

The Safety Board believes, however, that the controllers involved in this emergency should have, at some point, determined that the weather at MLI was much better than that at DBQ. Moreover, they should have been aware that CWI was much closer than either MLI or DBQ and then relayed that information to the pilots of N86SD. The air traffic control transcript revealed that an apparent lull in controller activity occurred shortly after N86SD was given the USQ weather. This would have been a good opportunity for the controllers to identify other possible diversion airports, obtain weather sequences for one or more of these airports, and then transmit some options to the pilots of N86SD. As it happened, of the several airports in the area with instrument approach capability and weather above instrument approach minimums, the pilots were given information on only one airport, DBQ.

Once a flight declares an emergency, the role of air traffic control reverts from one of controlling the flight to one of assisting the flight in safe recovery. Ideally, an exchange of information between the flightcrew and the controllers should have taken place to allow the safest resolution of the emergency situation. The controllers should not have hesitated to pass any potentially helpful information to the flightcrew, however sketchy that information might have been, thereby offering them the maximum number of options.

There were also systemic shortfalls that hindered the effectiveness of the assistance that the controllers could provide N86SD. These include a lack of readily available current weather sequence reports for the controllers, and a lack of written guidance for controllers during emergency situations.

2.4.1 Lack of Weather Sequence Reports Provided for Controllers

ARTCC radar controllers do not have an efficient means of searching through multiple weather sequences to locate the airport with the best weather conditions for landing or an adequate means of constantly displaying several terminal weather sequences. Of the several methods of obtaining current weather sequences, all are cumbersome and impractical during airborne emergency situations.

The Safety Board believes that hourly sequence reports for key airports should be constantly displayed on each sector in some manner.¹⁸ Having only the capability of "calling up" and preserving a single weather sequence is inadequate, as the circumstances of this accident indicate. Had the appropriate weather sequences been constantly displayed, the controllers would have been immediately aware that the weather in the MLI 2rea was considerably better. This knowledge would have provided N86SD a better opportunity to land without catastrophic consequences.

Pilots should not be expected to be familiar with all weather conditions on the surface along their entire route of flight. Although the flightcrew of N86SD could have inquired about better weather at some other airport during the emergency descent, the Safety Board believes that one or more of the Cotton High sector air traffic controllers should have had a readily available means to research this

¹⁸Such a practice was standard in ARTCCs prior to, and for a short time after, the advent of automated radar displays. An assistant controller manually copied the weather onto large "grease pencil" display boards in the radar room, a procedure that was somewhat labor intensive.

information for the flightcrew. If the controllers had automatically been provided the current weather at major airports in their sectors during the airborne emergency, their ability to assist the pilot would have been greatly enhanced. Therefore, the Safety Board believes that the FAA should provide all ARTCC sector positions of operation with the capability of displaying several hourly sequence reports at once. This display should be updated automatically and displayed at all times.

2.4.2 The Need for Additional Guidance for Controllers in Emergencies

Controllers do receive some level of emergency procedure training in initial and annual refresher training. However, the circumstances of this accident indicate that this training is inadequate. The Safety Board believes that the Air Traffic Control handbook that is the basis for controller training does not adequately address the issue of airborne emergencies in general. Further, concerning this accident sequence, the issue of finding the best possible weather for an IFR aircraft during an airborne emergency is not clearly addressed.

While there appears to be adequate information in the emergency assistance section of the handbook regarding VFR aircraft in weather difficulty, the handbook is somewhat vague in its one-sentence guidance that weather conditions should be considered for emergencies involving IFR-rated pilots. See appendix D. It does not mention the importance of finding the best possible landing weather for an IFR aircraft in an emergency status. Better landing weather conditions were not researched in a timely manner by the controllers attempting to aid N86SD during its emergency. This lapse led the Safety Board to believe that the written emergency procedure guidance in the ATC handbook is not specific enough, and that weather considerations were not adequately emphasized. The Safety Board therefore believes that the FAA should enhance the Emergency Assistance section of Air Traffic Control handbook 71.10.65 to fully address the issue of finding the best possible landing weather for an IFR aircraft in an emergency status (which is extremely important in the selection of the best possible diversion airport) and to emphasize this concept in emergency training scenarios.

Concerning the focus of general emergency procedures training for controllers, the Board agrees that providing training for every possible emergency scenario would not be practical. However, the Safety Board believes that the problem as basic as an emergency descent for landing through IFR conditions is a common one during many airborne emergencies and that more consideration should

be given in controller training for **this and other** common contingencies. Controller-to-pilot and pilot-to-controller communication **in** various emergency situations involving ~~a~~ traffic control should be emphasized in this training. Accident reports, such as **this** one, involving an emergency descent in IFR conditions, the El Al/Amsterdam E-747 accident,¹⁹ involving a loss of two engines **on** one side **with** turning difficulties, the Avianca Airlines/Kennedy B-707 accident,²⁰ involving imminent fuel exhaustion, and other reports, would be ideal training aids.

In all of these accidents, there was a lack of communication between pilots and controllers. The Safety Board believes that training scenarios should emphasize total, complete communication on the part of both pilots and controllers. If a pilot in an emergency status needs a closer airport, **has** difficulty making a particular **turn** or **is** running **out** of fuel, such problems **should** be **clearly** communicated to the controller. Likewise, if the controller has any information **or** options that he believes the pilot might consider, he **should** not hesitate **to** communicate this to the pilot.

At the time the flightcrew of N86SD began its descent, the controllers were only aware of the decompression, the Mayday call, and the request for lower altitude. At no time during the initial descent of the airplane were the controllers told about the engine-out condition and the airplane controllability problems, although they did surmise later that the airplane was having difficulty holding assigned altitudes.

¹⁹ El Al Boeing 747F, Registration 4X-AXG, Amsterdam, Holland, October 4, 1992. Report pending from the Government of the Netherlands.

²⁰ Aircraft Accident Report--"Avianca, The Airline of Colombia, Boeing 707-321B, HK 2016, Fuel Exhaustion, Cove Neck, New York, January 25, 1990" (NTSB/AAR-91/04)

3. CONCLUSIONS

3.1 Findings

1. N86SD was operated as a public **use** airplane **by** the State of South Dakota, and, therefore, its maintenance and **the** training of its pilots were not required to conform to Federal Aviation Regulations. The pilots were trained and the airplane was maintained in accordance with current State of South Dakota and manufacturer guidelines, and these guidelines conformed to **current** Federal Aviation Regulations.
2. During cruise **flight** at **FL** 240, a propeller hub **arm** on **the** left propeller failed, releasing the propeller blade attached to that hub **arm**. The released blade struck the following propeller blade and broke **the** tip off the following blade.
3. Severe engine vibration, caused by the missing propeller blade, caused an autonomous left engine shutdown.
4. During the event, the left engine was forced downward **and** inboard on **its** mounts. One or more of the remaining propeller blades, and/or a released blade tip from one of the remaining propeller blades, *might* have contacted **the** fuselage, causing a cabin decompression.
5. A lack of **damage** to the released propeller blade indicated that it did not contact the fuselage.
6. During a previous blade release **on** an MU-2B-60, the pilot was unable **to** arrest **his** descent. The damaged propeller on his airplane was feathered, and the failed engine nacelle was not canted away from the relative **wind**.
7. Due **to** drag caused by displacement of the left engine, sheet metal damage, and the **loss** of thrust of the left engine, the airplane was incapable of maintaining level flight.

8. The left propeller was last overhauled on September 11, 1990, in accordance with Hartzell procedures, at 3,914 hours of airframe total time, 671 hours before the accident.
9. The failure of the hub arm was the result of fatigue cracking that initiated from multiple initiation sites on the inside diameter surface of the hole for the pilot tube.
10. The fatigue properties of the hub were substantially reduced by a combination of factors, including machining marks or scratches, mixed microstructure, corrosion, decarburization, and residual stresses, and cracking would not have initiated if the properties had not been reduced.
11. Eased on the stress levels associated with the reactionless mode and the propensity of MU-2B airplanes to experience the reactionless mode at or above the ground idle RPM, the fatigue fracture of the hub is more likely to have initiated as a result of increased cyclic stresses produced during the reactionless mode of vibration, in combination with the substantially reduced fatigue properties of the hub material.
12. The precautions taken during the initial certification that were intended to minimize the exposure of propellers on MU-2B airplanes to the reactionless mode of vibration were inadequate.
13. There was no routine or special inspection in place at the time of the accident that were designed to detect the fatigue crack that precipitated the loss of the propeller blade. Subsequent to the accident, efforts to develop a practical, nondestructive test, without the removal of the pilot tubes to detect such an anomaly, were unsuccessful.
14. The pilots acted in a reasonable manner in continuing the high rate of descent to lower altitudes; and, once at lower altitudes, they continued to fly at higher airspeeds and rates of descent to gain more aerodynamic control.

15. Following the event, the Rightcrew asked for "the closest **airport**." The controllers offered the single option of ILS-equipped DBQ, **37 miles** away **from** the airplane. At that time, ILS-equipped CWI was 9 miles away, and ILS-equipped **MLI** was **39 miles** away. However, under all of these circumstances, this option was appropriate.
16. ARTCC sector positions of operation do not have the capability of displaying several hourly weather sequence reports at a time, being automatically updated, and being displayed at all times the actor is in operation.
17. The Emergency Assistance section of the Air Traffic Control handbook did not address the issue of finding the best possible weather **for an IFR aircraft in an emergency status**.

3.2 Probable Cause

The National Transportation Safety Board determines that the probable cause of this accident was the fatigue cracking and fracture of the propeller hub arm. The resultant separation of the hub arm and the propeller blade damaged the engine, nacelle, wing, and fuselage, thereby causing significant degradation to aircraft performance and control that made a successful landing problematic.

The cause of the propeller hub arm fracture was a reduction in the fatigue strength of the material because of manufacturing and time-related factors (decarburization, residual stress, corrosion, mixed microstructure, and **machining/scoring** marks) that reduced the fatigue resistance of the material, probably combined with exposure to higher-than-normal cyclic loads during operation of the propeller at a critical vibration frequency (reactionless mode), **which** was *not* appropriately considered during the airplane/propeller certification process.

4. RECOMMENDATIONS

As a result of this investigation, the National Transportation Safety Board makes the following recommendations:

--to the Federal Aviation Administration:

Determine whether any 4-bladed Hamell propeller hubs have ever been installed on MU-2B airplanes and are now installed on other model airplanes, and issue the necessary airworthiness directives to inspect the hubs for fatigue damage. (Class I, Urgent Action) (A-93-153)

Identify airplanes that can, through a combination of the resonant RPM, the ground idle RPM range, and repair limits at the blade tip, produce the reactionless mode in the normal operating range. For those airplanes containing Hartzell hubs at risk for reduced fatigue properties (manufactured prior to April 1984), require inspection for cracks in the pilot tube hole. (Class II, Priority Action) (A-93-153)

Perform a designated safety inspection for cracking in the pilot tube hole on high time Hartzell 3-, 4-, and 5-bladed propeller hubs that are found to have high operating stress and that were manufactured with the pilot tube holes finished machined prior to heat treatment. (Class II, Priority Action) (A-93-155)

Increase the minimum ground idle RPM speed of the HC-B4 propeller on the MU-2B airplane to provide a greater margin between the resonant frequency of the reactionless mode and the ground idle speed. (Class II, Priority Action) (A-93-154)

Revise maintenance and repair limits for propeller blades on HC-B4 hubs on MU-2B aircraft to reduce the length of the uncontrolled area at the blade tip to minimize the in-service increase in the reactionless mode frequency. (Class II, Priority Action) (A-93-157)

Enhance the Emergency Assistance section of Air Traffic Control handbook 7110.65 to fully address the issue of selecting the best possible diversion airport for an IFR aircraft in an emergency status. (Class II, Priority Action) (A-93-158)

Provide all ARTCC sector positions of operation with the capability of displaying several hourly weather sequence reports at once. This display should be updated automatically, and displayed at all times. (Class II, Priority Action) (A-93-159)

Provide expanded emergency procedures training for air traffic controllers. The general capabilities of airplanes in various emergency scenarios involving air traffic control should be a focal point of this training, and past air traffic control-related accident reports should be used. (Class II, Priority Action) (A-93-260)

BY THE NATIONAL TRANSPORTATION SAFETY BOARD

Carl W. Vogt
Chairman

Susan Coughlin
Vice Chairman

John K. Lauber
Member

John Hammerschmidt
Member

James E. Hall
Member

November 16, 1993

5. APPENDIXES

APPENDIX A

INVESTIGATION AND HEARING

1. Investigation

The National Transportation Safety Board was notified of the accident wound **1730** on **April 19, 1993**. The Safety Board has formal agreements with numerous federal and state agencies to investigate accidents involving "public use" airplanes. The State of South Dakota does not have such an agreement with the Safety Board, and, therefore, its public use airplane was not under the Safety Board's legislative mandate; however, senior officials from the Office of the Governor of South Dakota formally requested that the Safety Board lead the investigation of the accident.

An investigation team was dispatched from Washington, D.C., that evening and arrived at Zwingle, Iowa, shortly thereafter. On-scene investigative groups were formed for operations/human performance, structures/systems, and powerplants. Groups for metallurgy and air traffic control were also formed. Meteorology, maintenance records, aircraft performance and radar studies were also completed. Safety Board Vice Chairman Susan Coughlin accompanied the investigative team to Iowa.

Parties to the investigation included the State of South Dakota, Hartzell Propeller, Inc., Beech Aircraft Corporation, Allied-Signal Aerospace Company, the National Air Traffic Controllers Association, and the Federal Aviation Administration.

2. Public Hearing

There was no Safety Board public hearing associated with this investigation.

²¹ Beech Aircraft Corporation assumed product support responsibilities for the MU-2 on April 1, 1986.

APPENDIX B

RELEVANT RADIO TRANSCRIPTS



U.S. Department
of Transportation
**Federal Aviation
Administration**

Memorandum

Subject: INFORMATION: Transcription concerning
the accident involving N86SD on April 19,
1993, at 2053 UTC

Date: May 19, 1993

From: Air Traffic Manager
Chicago ARTCC, ZAU-1

Reply to
Attn of: L. Reilly:x315

To: This transcription covers the **time** period from April 19, 1993,
1930 UTC to April 19, 1993, 2056 UTC.

Aaencies Makino Transmissions
Indianapolis **ARTCC** Muncie Sector
Chicago ARTCC Sectors:

Xokomo
Logan
Bear:
Danville
Peotone
Joliet
Roberts
Bradford
Iowa City
Malta
Coton
Dubuque
Quad City ATCT Approach Control
Dubuque ATC Tower
Mitsubishi eight six sierra delta
Lear Jet **six** one eight romeo

Abbreviations

MIE
OKK
LGN
BRZ
DMV
EON
JOT
RBS
EDF
IOW
MAL
CTN
DBQ
QAPP
DBQT
N86SD
N618R

"R" after abbreviations refer to radar position and "D" refers
to manual position.

I **HEREBY CERTIFY** that the following is a true transcription of
the recorded conversations pertaining to the subject aircraft
accident:

THOMAS F. REISEL

Quality Assurance Specialist
TITLE

11

2038 :27 IOWD RU
(2039)
(2040)
2040:22 N86SD Chicago ahh sierra delta we had ahh a
decompression

2040:27 CTNR November eight six sierra delta say again

2040:33 N86SD Mayday mayday mayday six sierra delta we're
goin down here

2040:43 CTNR November eight six sierra delta roger tell
me what you need I got your mayday

2040:46 N86SD We need the closest airport we can get to
here

2040:50 CTNR November eight six sierra delta roger you
understand you need an airport Dubuque
airport is off to your two o'clock and
twenty five miles can you land there

2041:00 N86SD Ah thats Dubuque off ah to our left and
twenty five

2041:04 CTNR Eight six sierra delta affirmative thats
Dubuque airport

2041:17 CTNR November eight six sierra delta you still
with me

2041:19 N86SD Thats affirm

2041:22 CTNR Eight six sierra delta roger what altitude
do you need we'll get it for you we'll clear
everybody out of your way

2041:28 N86SD (Unintelligible) we need to get down to ah
our oxygen level here

12

2041:34 CTNR Eight **six** sierra delta roger descend **and** maintain eight thousand

2041:37 N86SD Goin down **to** eight

2041:39 CTNR Eight **six** sierra delta **Okay I'll** have an altimeter for ya in just one **moment**

2041:41 CTNR November eight six sierra delta Dubuque altimeter two niner four five two niner four five

2041:49 N86SD Two niner **four** five roger

2041:50 CTNR Eight six sierra delta **can you** switch over **to** a low altitude frequency are you gonna have any **problem with that** or **do** you jast wanna stay **with** me

2041:57 DBQD Quad City approach Chicago got an emergency

2041:59 QAPP Go ahead we're on

2042:00 DBQD Yeah just ah northeast of Davenport fifteen miles that emergency squawk you're seein **he's** going down to eight right now

2042:00 N86SD Yeah we can **do** it we **can** change **the** frequency

2042:04 CTNR Okay eight six sierra delta **low** altitude sector frequency one three three point niner five one thirty **three** ninety **five**

2042:05 QAPP Descending **to** eight **thousand**

2042:07 DBQD Yeah

2042:08 QAPP Point out approved

13

2042:08 DBQD *(VU)

2042:09 QAPP Let us know if you need anything else

2042:11 DBQD Thank you

2042:12 QAPP Charlie mike

2042:12 N86SD *(We need the weather here) Thirty three
ninety five ahh do you have the weather at
Dubuque

2042:16 CTNR Roger eight six sierra delta roger and you
are cleared to Dubuque that's about a ah
three thirty heading direct when able you
are cleared to Dubuque airport and ah if you
want the weather I've got it for you right
now

2042:28 N86SD Go ahead

2042:32 CTNR Okay it's a special measured ceiling three
hundred overcast visibility one and one half
with rain and fog the winds are zero six
zero at twenty knots

2543:05 CTNR November eight six-sierra delta you still
wifh me

2043:08 N86SD Affirm we're still with ya

2043:11 CTNR Okay eight six sierra delta can you switch
over now to thirty three ninety five

2043:13 N86SD That's affirm we'll give it a try

2043:16 CTNR Okay if you have any problems come back
right to me

14

2043:40 N86SD And Chicago ah six sierra delta is with ya
ah level at eight thousand here thirty three
ninety five

2043:45 DBQR Eighty *six* sierra delta fly heading three
six zero radar vectors for the ILS do you
want equipment standing by

2043:51 N86SD *Three six zero and ah we might need the*
equipment also ah ah okay eh the altitude

2044:00 DBQR Okay do you have charts for the ILS there at
Dubuque

2044:02 N86SD Affirm

2044:04 DBQR Okay three sixty on the heading radar vector
for ILS

2044:07 N86SD Okay

2044:08 DBQR Can you hold altitude

2044:11 N86SD Well standby

2044:14 DBQR Maintair, six thousand eight six sierra delta

2044:18 DBQR Quad City approach Chicago

2044:19 N86SD Down to six

2044:21 DBQR Roger

2044:22 QAPP Quad City

2044:23 DBQR Yeah that ah eight *six* sierra delta he's
going down all the way to about three
thousand I guess

15

2044 :27 QAPP Eight *six* sierra delta

2044 :29 DBQD Yeah the one had an emergency you're watching four zero five *four*

2044 :31 QAPP (Unintelligible)

2044:33 QAPP *Are* you heading for Dubuque with him

2044:34 DBQD Yeah that's what he wanted

2044:35 QAPP Okay charlie mike

2044 :36 DBQD VU

2045:15 DBQR And eight six sierra delta it appears you can have ah hold six thousand for awhile sir

2045:20 N86SD It don't look like it ah were having a hard time holding altitude here

2045:27 DBQR Okay descend and maintain four thousand at pilot's discretion you can hold as high as you can for as long as you can and fly heading now three four zero

2045:36 N86SD Three four zero roger that

2046:21 N86SD Yeah approach ah six SD

2046:23 DBQR I'm *sorry* missed it try it again

2046:31 N618R Lear *six* one eight romeo request about tea degrees right to avoid a buildup ahead

2046:35 DBQR That's approved sir you're twenty three miles southeast of Dubuque when you can join the localizer on that three forty it would

16

have been about in a minute or two join the ILS to runway three one you're able you're able

2046:51 N86SD Ah approach six sierra delta how far are we from Dubuque

2046:56 DBQR Showing you twenty three miles southeast

2046:58 N86SD Okay ah if you can give us vectors ah for the IIS we'd appreciate it

2047:02 N86SD Okay fly heading of ah three four zero when you're able join the ILS you're about one minute south of joining the ILS

2047:08 N86SD Roger that

2047:48 DBQR Eight six sierra delta I show you joining the localizer at this time do you concur sir

2047:52 N86SD That's affirm and ah could you have an ambulance stand by

2047:56 DBQR Yes sir we've we're talked to em

2048:00 DBQR All the coordination has been done

2048:02 N86SD * (Thank you)

2048:04 DBQR Touer Dubuque Tower Chicago

2048:06 N86SD Yeah we've got an engine out and ah ah decompression

2048:08 DBQT Yeah tower cab

17

2048:10 DBQD (Unintelligible) we got eight six sierra bravo

2048:10 (Unintelligible)

2048:13 DBQT Yes

2048:15 DBQD Re's got an engine out we got an *emergency*

2048:17 DBQT Okay

2048:18 DBQD One engine out decompression he wants all the equipment standing by he wants an ambulance standing by

2048:25 DBQT Okay we'll have it all here

2048:26 DBQD (Unintelligible)

2048:27 DBQT DB

2048:52 DBQR Eight six sierra delta cleared for the straight in ILS approach to ah ah runway three one you're position is ah ten miles south about nine miles southsast of ZILOM at this time maintain ah ah well I see you're through it I was gonna tell you to maintain thirty three hundred ah till established

2049:06 N86SD Okay

2049:18 DBQR Dubuque Chicago

2049:20 DBQT Dubuque tower

18

2049:21 DBQR I don't know if ah eight six sierra delta is gonna make it he's about eight southeast of ah ZILOM at twenty seven hundred and he can't hold altitude so start looking out that southeast window if you can

2049:33 DBQT Okay we'll do it

2049:34 DBQR You got plenty of vehicles there whatever he needs

2049:36 DBQT Yeah we're gettin em all were gettin em out now

2049:38 DEQR Just lost him on radar

2049:39 DBQT Alright DB

2049:40 DBQR Maybe alert the state police

2049:42 DBQT Wilco

2049:44 DBQR Eight six sierra delta Chicago

2049:45 N86SD Go ahead

2049:46 DBQR They've got all the equipment ah and everything ready for ya

2049:49 N86SD Okay

2049:51 DBQR Can you hold at least twenty seven hundred there sir

2049:53 N86SD I don't think so

2050:02 DBQR I'm shoving you thirteen miles southeast eight six sierra delta

19

2050:06 N86SD Roger that

2050:32 DBQR Eight six sierra delta say *the* altitude

2050:36 N86SD We're at nineteen hundred

2050:37 DBQR Okay you're still about ten miles southeast of *the* airport

2050:42 N86SD Okay

2051:10 DBQR Eight six s i e m delta radar contact is lost contact Dubuque tower now on one one nine point five

2051:15 N86SD Nineteen five thanks
(2052)
(2053)
(2054)
(2055)
(2056)

END OF TRANSCRIPT

* This portion of the rerecording is not entirely clear, but this represents the best interpretation possible under the circumstances.



U.S. Department
of Transportation
Federal Aviation
Administration

Memorandum

Subject: INFORMATION: Transcription concerning the accident involving N86SD on April 19, 1993 at 2053 UTC Date: APR 23 1993

From: Jon Croft Reply to
Air Traffic Manager, Dubuque ATC Tower Attn. of:

To: This transcription covers the time period from April 19, 1993, 2045 UTC to April 19, 1993, 2058 UTC

Agencies Making Transmissions

Dubuque ATC Tower
Chicago ARTCC
N86SD
Airport Rescue and Fire Fighting
Unknown

Abbreviations

DBQ
ZAU
N86SD
ARFF
UNK

I hereby certify that the following is a true transcription of the rerecorded conversations pertaining to the subject accident involving N86SD:

Jon Croft
Air Traffic Manager
April 23, 1993

This portion of the transcript identifies communication at the Ground Control position from the period 2045 UTC to 2058 UTC.

(2045)

2045:03 ZAU Hey Dubuque Tower Flow

2045:06 DBQ Dubuque Tower

"Train to Succeed"

2045:0f ZAU Yeah you know you got the emergency comin towards you

2045:09 DBQ No

2045:10 ZAU OK you dont know anything about it

2045:11 DBQ NO

2045:12 ZAU Hold on one second

2045:16 ZAU Eight Six Sierra Deltas comin towards you I dont know all the specifics yet but he is an emergency priority aircraft

2045:23 DBQ Do you know anything at all what the nature of the emergency is

2045:26 ZAU Hang on one second I got it right here

2045:40 ZAU OK all we got right now so far is that he had a pressurization problem and he needed immediate descent I dont know if hes see Im getting this second hand so I dont want to lose a lot of It in the translation

2045:51 DBQ Can you tell me his position now

2045:53 ZAU His position now is about twenty five southeast of the airport hes at fifty seven hundred feet

2045:57 DBQ Is he going to do the ILS

(2046)

2046:01 ZAU I dont know what approach hes going to do

2046:03 DBQ OK

2046:04 ZAU All right as soon as you get a down time on him would you report it back to us please

2046:07 DBQ OK what yeah twenty two

2046:09 ZAU Yes

2046:10 DBQ MC

2046:11 ZAU Thank you CM

(2047)

(2048)

(2049)

(2050)

(2051)

2051:06 ARFF Ground. Red Five

2051:08 DBQ Red Five Dubuque Ground

2051:11 ARFF Roger was that a One Three or a Three One approach

2051:17 DBQ Red Five he'll be doing an ILS Runway 31 2nd have you advised ambulances are they enroute

2051:26 ARFF Xmbulance 2nd additional fire units have been notified by nine one one I'll be prestaglng at Delta Two and Runway One Three Three One

2051:41 DBQ Red Five you can proceed on Delta One hold short of Runway Three One

2051:45 ARFF Roger

(2052)

(2053)

2053:55 UNK (sound of transmitter keying two times)

(2054)
(2055)

2055:12 ARFF Ground Red four

2055:14 DBQ Red Four Dubuque Ground

2055:16 ARFF Yes would you advise that ambulance that I'm waiting for him on the road I'll give him an escort in he should follow me

2055:23 DSQ Red Four Im not in contact with the ambulance if they call me I'll relay that

2055:27 ARFF Roger that

(2056)
(2057)
(2058)

This portion of the transcript identifies communications at the Local Control position from the period 2045 3TC to 2058 UTC.

(2045)
(2046)
(2047)

2047:57 ZAU Tower Dubuque Tower Chicago

(2048)

2048:03 DBQ Yeah tower cab

2048:06 ZAU Yeah we got Eight Six Sierra Bravo has got one engine out we got an emergency

2048:11 ZAU One engine out decompression he wants all the equipment standing by he wants an ambulance standing by

2048:18 DBQ OK we'll have it all here

2048:20 ZAU OK BO

2048:21 DBQ Ali right DB

(2049)

2049:12 ZAU Dubuque Chicago

2049:14 DBQ Duhuque Tower

2049:15 ZAU i dont know if Eight Six Sierra Deltas gonna make it hes about eight southeast of the Zilom now hes at twenty seven hundred he cant hold altitude so start looking out that southeast window if you can

2049:23 DBQ OK we'll do it

2049:24 ZAU And you got plenty of vehicles there or whatever he needs

2049:27 DBQ Yes we're getting them all we're getting them out right now

2049:30 ZAU OK I just lost him on radar

2049:31 DBQ All right DB

2049:34 ZAU Yeah maybe alert the state police

2049:36 DBQ Wilco

2049:36 ZAU CM

(2050)
(2051)

2051:15 N86SB Dubuque Tower Mitsubishi Eight Six Sierra Deltas with you

2051:18 DBQ Mitsubishi Eight Six Sierra Delta Dubuque Tower we have all the lights on high the emergency vehicles are on their way out wind zero four zero at fifteen altimeter two niner four five you are cleared to land Runway three one

2051:35 N86SD Sierra Delta roger

2051:40 ZAU And Dubuque

2051:42 DBQ Dubuque Tower go ahead

2051:44 ZAU Sierra Delta I lost him about twelve (unintelligible) about eight miles to the southeast

2051:48 DBQ We're talking to him

2051:49 ZAU OK hes having a problem holding altitude

2051:52 DBQ All right DB

2051:57 N86SD How far out are we

2051:59 DBQ Six Sierra Delta lost radar contact on you approximately six to eight miles from the field do you have DME

2052:09 N86SD Yeah

(2053)

2053:16 DBQ Mitsubishi Eight Six Sierra Delta wind zero five zero at fifteen previous arrivals have reported plus or minus five to ten knots wind shear on approach and tower visibility now is a good two miles

2053:40 DBQ Mitsubishi Eight Six Sierra Delta if you have time just, key your mic a couple of times so we'll know you're still with us

2053:58 DBQ Mitsubishi Eight Six Sierra Delta Dubuque Tower do you read

2054:51 DBQ Mitsubishi Eight Six Sierra Delta Dubuque Tower

(2055)

2055:27 DBQ Mitsubishi Eight Six Sierra Delta Dubuque Tower do you read

(2056)
 (2057)
 (2058)

This portion of the transcript identifies communication at the Supervisor Cab position from the period 2045 UTC to 2058 UTC.

(2045)
 (2046)
 (2047)
 (2048)
 (2049)
 (2050)
 (2051)
 (2052)
 (2053)
 (2054)
 (2055)
 (2056)

2056:10 DBQ Chicago Center Dubuque Tower

2056:12 ZAU Dubuque Sector

2056:16 DBQ

He have an unofficial report that he might not of made it and might have hit a building five southeast are you do you have any airplanes in the area that could monitor the emergency frequency for an ELT

2056:23 ZAU

Yes we do we'll do that

2056:31 DBQ

Let me know if you get the ELT then

2056:34 ZAU

OK BO

(2057)

(2058)

END OF TRANSCRIPT

APPENDIX C

**SAFETY BOARD RECOMMENDATIONS A-82-81 THROUGH -83
CORRESPONDENCE HISTORY**

On September 27, 1991, a Mitsubishi MU-2B-60, on a cargo **flight**, sustained substantial damage when a propeller blade separated in flight near Utica, New **York**. The airplane was climbing through **19,000** feet when the pilot felt a strong vibration, followed shortly by a loud "bang." The vibration increased and became so severe that the pilot experienced **considerable** control difficulty. The airplane was successfully landed at the **Utica** Airport, with no injuries. As a result of **its** investigation of **this** accident, the Safety Board addressed **three** safety recommendations **to** the Federal Aviation Administration. These recommendations were issued on August **13, 1992**, and **are as** follows:

A-92-81

Develop, **with** the assistance **of** Hartzell Propeller, Incorporated, a nondestructive inspection technique capable of detecting hub **arm** cracks stemming **from** the inside diameter surface of the hub **arm** at **the** approximate location of the inserted end of tie pilot tubes on Hartzell model HC-B4 propeller hubs, and issue an Airworthiness Directive requiring that HC-B4 hubs with 3,000 hours or more be inspected using this technique the next time **the** propeller assembly is overhauled for any reason, or at the next annual inspection (or equivalent), whichever is first.

A-92-82

Determine, based on the results of the inspections requested in Safety Recommendation **A-92-81**, if the hub arms on Hamell Model HC-B4 propeller hubs with 3,000 hours or more should be inspected at periodic intervals. If such inspections are warranted, issue an Airworthiness Directive, as appropriate, requiring periodic inspections.

A-92-83

Determine if Hartzell model **HC-B3** and **-B5** propeller hubs, based on **similarity** of design and fabrication processes with the **HC-B4** propeller hub, should be inspected **for** cracking in the hub arms. If such inspections **are** warranted, issue an Airworthiness Directive, as appropriate, requiring periodic inspections.

The **FAA** first responded *to* these **recommendations** in letters of October **26, 1992**, and January **4, 1993**, respectively. The **FAA** stated in the first letter that the service history of the Hartzell propeller hubs was being reviewed to determine the **magnitude** of the problem, as well as the service manuals, **to** determine what, if any, changes needed to be made. **In** the second letter, the **FAA** pointed out that the review **of** the service history had been completed and that only one **failure** (the one on September **27, 1991**) had been found. The **FAA** further noted that the stress levels in the crack initiation area are acceptable, and that the hubs **are** currently subjected to a magnetic particle inspection during overhaul every 3,000 hours. The **FAA** stated that no additional action was planned, but that Hartzell would continue to monitor the service history of the propeller.

The Board replied to these **FAA** responses in letters dated January **6, 1993**, and March **4, 1993**, respectively. **In** these replies, the Board noted that the **FAA** service history study **of** Hartzell propeller hubs had been initiated and completed and that the **FAA** planned no further action other than having Hartzell **monitor** the situation. **The** Board strongly stated that regardless of the finding that the service history of the **HC-B4** hubs contained *no* other examples of cracking or fractures similar to the Utica accident, the Board was convinced that a once-through-the-feet inspection of the subject hubs was necessary, as requested **in** Safety Recommendation **A-92-81**.

Further, in its March **4, 1993**, reply, the Board stated its concern that the **FAA** had not taken action in the interim to examine the **possibility of** using a more appropriate method to inspect the hub arms; and that the **FAA** saw **no** need to review the **design and** fabrication process of other Hartzell propeller hub models to determine if **similarities** in design might indicate the need for inspection of these other hub models. Because of these concerns and because the Board did **not** believe that the **FAA** had addressed these recommendations in sufficient detail, Safety Recommendations **A-92-81** through **-83** were classified as "Open--Unacceptable Response."

On April 19, 1993, the accident occurred at Zwingle, Iowa, involving an identical Mitsubishi model airplane and Hartzell propeller. The FAA responded a third time to Safety Recommendations A-92-81 through -83 on May 21, 1993. Primarily as a result of the Zwingle, Iowa, accident, the FAA pointed out that it had taken actions, or was considering a wide range of actions, that were designed to be responsive to the subject recommendations.

In a June 21, 1993, letter, the Safety Board accepted the actions taken and those planned by the FAA as an excellent start in addressing the safety issues that prompted Safety Recommendations A-92-81 through -83. Pending receipt of additional information concerning the progress of these activities, Safety Recommendations A-92-81 through -83 were classified as "Open--Acceptable Response."

The FAA has not responded further since the Board's June 21, 1993, reply.

The following are copies of the actual correspondence:

JUN 21 1993

Mr. Joseph M. Dei Balzo
Acting Administrator
Federal Aviation Administration
Washington, D.C. 20591

Wear **Mr.** Del Balzo:

Thank you for the Federal Aviation Administration (FAA) letter dated May 21, 1993, further responding to Safety Recommendations A-92-81 through -83. These recommendations resulted from the National Transportation Safety Board's investigation of an accident in which a Mubushi **MU-28-60** airplane sustained substantial damage when one of the four blades on the Hartzell **HC-B4** propeller on the right engine separated from the propeller while in flight near Utica, New York, on September 27, 1991.

The Safety Board determined that the propeller blade separated from the propeller because of fatigue cracking that initiated from the inside diameter surface of one of the four arms of the propeller hub. Safety Recommendation A-92-81 asked the FAA to develop, with Hartzell's assistance, an inspection method capable of detecting hub arm cracks and to issue an airworthiness directive (AD) requiring that HC-B4 hubs with over 3,000 hours be inspected. Safety Recommendation A-92-82 asked the FAA to mandate repeated inspections of the affected hubs, if so warranted by the results of the initial inspections. Safety Recommendation A-92-83 asked the FAA to determine if other similarly designed Hartzell propeller hubs should also be inspected for cracking.

Your letter indicates that the FAA agrees with the recommendations and has taken or is considering the following actions to address the safety issues regarding the two failures on Hartzell Model **HC-B4TN-5** steel hubs:

On April 29, 1993, the FAA issued AD 93-09-04, requiring removal of the pilot tubes and inspection of the hub arms on **HC-B4TN-5** hubs installed on Mitsubishi **MU-2B-60** airplanes. Since issuance of the AD, mandated inspections have found an indication of a crack in one hub arm.

Hartzell and FAA nondestructive inspection (NDI) specialists will conduct a comprehensive study to determine if ultrasonic inspection techniques can provide a viable and reliable inspection procedure to detect cracks in the hub arm where the previous failures have occurred.

New laboratory and flight testing activities will be conducted to explore numerous failure theories and to help determine the cause of the failures.

The applicability of AD 93-09-04 will be expanded to include additional **MU-28** model airplanes with similar operational characteristics. Hartzell is developing service documentation and part logistics to support this effort.

The results of test5 and analyses, once completed, will be reviewed to determine what additional actions will be needed to address all remaining models of the Hartzell steel hub design.

The Safety Board believes that the actions taken and planned by the **FAA** are an excellent start in addressing the safety issue that prompted Safety Recommendations A-92-81 through -83. Pending receipt of additional information concerning the progress of these activities, Safety Recommendations A-92-81 through -83 are classified 'Open—Acceptable Response.' *

Sincerely,

Original Signed By
Susan Coughlin

Carl W. Vogt
Chairman

cc: Robert P. Thurber
Acting Director
Office of Transportation Regulatory Affairs



U.S. Department
of Transportation
Federal Aviation
Administration

97

Office of the Administrator

800 Independence Ave., S.W.
Washington, G.C. 20591

MAY 21 1993

The Honorable Carl W. Vogt
Chairman, National Transportation
Safety Board
490 L'Enfant Plaza East, SW.
Washington, DC 20594

Dear Mr. Chairman:

This is in further response to Safety Recommendations A-92-81 through -83 issued by the Board on August 13, 1992, and supplements our letters dated October 26, 1992, and January 4, 1993. These safety recommendations were issued as a result of the Board's investigation of an accident on September 27, 1991, involving a Mitsubishi MU-2B-60, Canadian registry C-FFSS, which was on a cargo flight. The airplane sustained substantial damage when a propeller blade separated in flight near Utica, New York. The airplane was climbing through flight level 190 when the pilot felt a strong vibration, followed shortly by a loud "bang." The vibration increased and became so severe that the pilot experienced considerable difficulty controlling the airplane. Despite this difficulty, the airplane landed at Utica Airport. There were no injuries.

A-92-81. Develop, with the assistance of Hartzell Propeller, Incorporated, a nondestructive inspection technique capable of detecting hub arm cracks stemming from the inside diameter surface of the hub arm at the approximate location of the inserted end of the pilot tubes on Hartzell model HC-B4 propeller hubs, and issue an airworthiness directive requiring that HC-B4 hubs with 3,000 hours or more be inspected using this technique the next time the propeller assembly is overhauled for any reason, or at the next annual inspection (or equivalent), whichever is first.

- 82. Determine, based on the results of the inspections requested in Safety Recommendation A-92-81, if the hub arms on Hartzell model HC-B4 propeller hubs with 3,000 hours or more should be inspected at periodic intervals. If such inspections are warranted, issue an airworthiness directive, as appropriate, requiring periodic inspections.

A-92-83. Determine if Hartzell model HC-B3 and -B5 propeller hubs, based on similarity of design and fabrication processes with the HC-B4 propeller hub, should be inspected for cracking in the hub arms. If such inspections are warranted, issue an airworthiness directive, as appropriate, requiring periodic inspections.

FAA Comment. The Federal Aviation Administration (FAA) agrees with the Board's recommendations and has taken the following actions to address the safety recommendations regarding the two failures on Hartzell Propeller Inc., Model HC-B4TN-5 steel hubs:

The FAA issued priority letter Airworthiness Directive (AD) 93-09-04 to require an inspection of all HC-B4TN-5 model steel hubs installed on Mitsubishi MU-2B-60 model airplanes. This action requires that all MU-2B-60 propellers be removed from the airplanes, disassembled, and the hub assemblies shipped to Hartzell for specific inspection and rework. At Hartzell, the pilot tubes are removed from the hub arms and the bores are inspected using a magnetic particle process. Hub arm bores that pass the inspection are reworked and reassembled with new pilot tubes. These reworked hubs will be repetitively inspected every 600 hours time-in-service. The FAA's National Resource Specialist for nondestructive inspection (NDI) has reviewed and concurred with the inspection procedures.

As a result of the inspections required by the AD, one hub arm crack indication has been found to date. The Safety Board was notified and an investigation was started to verify the crack indication utilizing several NDI processes, including magnetic particle, eddy current, dye penetrant, and ultrasonic. An effort is underway in coordination with the Safety Board's specialists to nondestructively characterize the suspected crack's location, length, depth, and orientation with ultrasonic and eddy current techniques. Radiographic procedures are also being explored. The objective is to correlate the NDI results with the forthcoming destructive tests to determine the viability of using NDI techniques for future inspections.

Hartzell has retained an NDI specialist who has over 20 years experience in NDI technology with specific expertise in ultrasonic inspection. This expert will work with Hartzell and FAA specialists to conduct a comprehensive study to determine if ultrasonic inspection techniques can provide a viable and reliable inspection procedure to detect cracks in the hub arm where the previous failures have occurred. The study will examine test methods on hubs with and without the pilot tubes installed.

Crack characterization destructive tests are also planned and will be coordinated with the Safety Board. Hartzell has proposed that the hub arm with the crack indication be sectioned and a tensile specimen be created from the crack indication area. This specimen will be fracture toughness tested in accordance with American Society of Testing and Materials E399 test procedures. This test will provide information required to establish the loads present during the final moments prior to hub failure.

The characteristics of the crack surface should not be affected by the fracture toughness testing. The test plan proposal is being developed and will be coordinated with the Safety Board.

The FAA has consulted with Hartzell and has defined new laboratory and flight testing activities which will explore numerous failure theories and help determine the cause of the failures.

Hartzell will conduct a new flight strain survey of the HC-84TN-5 model propeller as installed on the MU-2B-60 model airplane. The test propeller will have strain gauges located near the suspect area in the propeller hub ann bore. The FAA is reviewing the test plan proposal and Hartzell has scheduled preliminary flight testing of this installation to begin today.

Hartzell will also conduct laboratory testing using various sized pilot tubes pressed into a representative hub arm configuration with strain gauges located on the inner surface bore of the hub arm. The tests will measure the stress loadings caused by the interference fit between the pilot tube and hub arm. Additionally, a static test will be conducted to determine if an improperly fitting blade clamp could cause additional stress loadings in the hub arm.

Based on the results of above tests, Hartzell will update the finite element modeling and fracture mechanics analysis to help determine the cause of the hub arm failures. Additionally, a comprehensive review of the current maintenance instructions and manufacturing procedures will be performed using data developed from the interference fit and blade clamp tests.

The FAA will expand the applicability of AD 93-09-04 to include additional MU-2B model airplanes due to the similar operational characteristics of these type design configurations. Hartzell is developing service documentation and part logistics to support this effort.

Once all tests and analyses are completed, the FAA will review the data to determine what additional actions will be needed to address all remaining models of the Hartzell steel hub design.

The FAA will continue to coordinate all activities associated with this investigation with the Safety Board.

Sincerely,

Joseph M. Del Balzo
Acting Administrator

MAR 4 1993

Mr. Joseph M. Del Balzo
Acting Administrator
Federal Aviation Administration
Washington, D.C. 20591

Dear Mr. Del Balzo:

Thank you for the Federal Aviation Administration (FAA) letter dated January 4, 1993, further responding to Safety Recommendations A-92-81 through -83. These recommendations resulted from the National Transportation Safety Board's investigation of an accident involving a Mitsubishi MU-2B-60 airplane that sustained damage when one of the four blades of the Hartzell HC-B4 propeller on the right engine separated from the propeller while in flight near Utica, New York, on September 27, 1991.

The Safety Board determined that the propeller blade separated from the propeller because of fatigue cracking that initiated from the inside diameter surface of one of the arms of the propeller hub. Safety Recommendation A-92-81 asked the FAA to develop, with Hartzell's assistance, an inspection method capable of detecting hub arm cracks and to issue an airworthiness directive (AD) requiring that HC-B4 hubs with over 3,000 hours be inspected. Safety Recommendation A-92-82 asked the FAA to mandate repeated inspections of the affected hubs, if so warranted by the results of the initial inspections. Safety Recommendation A-92-83 asked the FAA to determine if other similarly designed Hartzell propeller hubs should also be inspected for cracking.

Your letter indicates that propeller hubs used on the Hartzell HC-B3, HC-B4, and HC-B5 propellers have accumulated a large amount of service time with only one reported failure of a hub arm. Hartzell procedures recommend a magnetic particle inspection each time the hub is overhauled (every 3,000 hours). Your letter indicates that an airworthiness directive is not necessary, based on the service history and the presence of the magnetic particle inspection in the overhaul procedures.

The area from which the cracking initiated on the propeller hub from the Utica, New York, incident was the inside diameter surface of the hub arm, at a location approximately corresponding to the end of the pilot tube. This area contained scratches that were probably introduced during the original manufacturing of the hub, and it is possible that other hubs have similar scratches that could cause crack initiation. A representative of Hartzell indicated to the Safety Board that magnetic particle inspections of the hubs in question are normally performed without removal of the pilot tubes from the hub arms. Because the pilot tubes are assembled to the hub with an

interference fit, disassembly of a tube is difficult and can damage the surface of the hub arm hole. Therefore, a pilot tube would be removed during overhaul only if it was damaged or worn.

Without the removal of the pilot tube, a crack that initiates at the inside diameter of the hub arm will not be detectable by magnetic particle inspection until it penetrates or nearly penetrates the outer surface of the hub arm. The Safety Board believes that a crack of this size would propagate to failure in much less than 3,000 hours of operation. Therefore, magnetic particle inspection performed during overhaul with the pilot tubes in place is an inappropriate method for detecting cracks of this type. The Safety Board still believes that an appropriate inspection method, such as ultrasonic inspection, needs to be developed and applied to the hubs of the HC-B4 propeller.

Separation of a blade from a Hartzell HC-B4 propeller on another airplane could result in a catastrophic accident. The Safety Board notes that the FAA is continuing to monitor and is awaiting the outcome of Hartzell's continuing investigation. However, the Board is concerned that the FAA has not taken action in the interim to examine the possibility of using a more appropriate method to inspect the hub arms. Further, the Board is concerned that the FAA sees no need to review the design and fabrication process of other Hartzell propeller hub models to determine if similarities in design might indicate the need for inspection of these other hub models. Because of these concerns and because the Safety Board does not believe that the FAA has addressed these recommendations in sufficient detail, we have classified Safety Recommendations A-92-81, -82, and -83 as "Open--Unacceptable Response."

The Board looks forward to receiving a report on the findings from the Hartzell continuing investigation and a report on the FAA's own analysis of the situation as the monitoring continues. While the Hartzell investigation progresses, the Board encourages the FAA to develop an inspection method that could efficiently detect the type of flaw that caused this accident without removal of the pilot tubes from the hub arms.

Sincerely,

Original Signed By
Carl W. Vogt

Carl W. Vogt
Chairman

cc: Mr. Donald R. Trilling
Director
Office of Transportation Regulatory Affairs



U.S. Department
of Transportation
**Federal Aviation
Administration**

Office of the Administrator

600 Independence Ave., S.W.
Washington, D.C. 20591

JAN 4 1993

The Honorable Carl W. Vogt
Chairman, National Transportation
Safety Board
490 L'Enfant Plaza East, SW.
Washington, DC 20594

Dear Mr. Chairman:

This is in further response to Safety Recommendations A-92-81 through -83 issued by the Board on August 13, 1992, and supplements our letter dated October 26, 1992. These safety recommendations were issued as a result of the Board's investigation of an accident on September 27, 1991, involving a Mitsubishi MU-2B-60, Canadian registry C-FFSS, which was on a cargo flight. The airplane sustained substantial damage when a propeller blade separated in flight near Utica, New York. The airplane was climbing through flight level 190 when the pilot felt a strong vibration, followed shortly by a loud "bang." The vibration increased and became so severe that the pilot experienced considerable difficulty controlling the airplane. Despite this difficulty, the airplane landed at Utica Airport. There were no injuries.

81. Develop, with the assistance of Kartzell Propeller, Incorporated, a nondestructive inspection technique capable of detecting hub arm cracks stemming from the inside diameter surface of the hub arms at the approximate location of the inserted end of the pilot tubes on Hartzell model HC-B4 propeller hubs, and issue an airworthiness directive requiring that HC-B4 hubs with 3,000 hours or more be inspected using Mis technique the next time the propeller assembly is overhauled for any reason, or at the next annual inspection (or equivalent), whichever is first.

8-92-82. Determine, based on the results of the inspections requested in Safety Recommendation A-92-81, if the hub arms on Hartzell model HC-B4 propeller hubs with 3,000 hours or more should be inspected at periodic intervals. If such inspections are warranted, issue an airworthiness directive, as appropriate, requiring periodic inspections.

83. Determine if Hartzell model HC-B3 and -B5 propeller hubs, based on similarity of design and fabrication processes with the HC-B4 propeller hub, should be inspected for cracking in the hub arms. If such inspections are warranted, issue an airworthiness directive, as appropriate, requiring periodic inspections.

FAA Comment. The Federal Aviation Administration (FAA) agrees with the intent of these safety recommendations but does not believe that airworthiness directive action is required. The FAA completed its review of the service history of the Hartzell Propeller steel hub designs. To date, the one failure described by the Safety Board is the only known failure of a Hartzell steel hub design. The FAA and Hartzell Propeller have independently reviewed their own service difficulty records to determine if cracks in the hub had been found during magnetic particle inspections. No reports of cracks in *this* area had been found.

The Safety Board indicates that over 28,000 HC-B3 and HC-B5 steel hub propellers are in service. These propeller designs have accumulated millions of safe flight hours. The Hartzell HC-B4 design has also accumulated a significant service history with one reported failure of the steel hub arm. Hartzell Propeller has conducted an extensive analysis on the HC-B4 hub design as installed on the Mitsubishi MU-2B-60 to try to determine the cause of the failure. A finite element modeling of this area has been accomplished and Hartzell Propeller has indicated to the FAA that stress levels in this area are acceptable even with varying degrees of interference fit between the pilot bore and the pilot tube. No metallurgical discrepancies were found in the hub material. Hartzell Propeller is continuing its investigation and will provide the FAA with its findings.

The Safety Board recommends that all steel hub propellers be inspected at the 3,030-hour service interval or at the next annual inspection, whichever occurs first. Hartzell Propeller procedures already require a magnetic particle inspection on steel hub designs when the propeller is overhauled. The manufacturer's recommended interval is 3,000 Hours time-in-service per Hartzell Service-Letter 61R. Based on the service history and the fact that current procedures require inspection at 3,000-hour service intervals, the FAA does not believe that an airworthiness directive is necessary at this time. The FAA will continue to monitor the service history of these hub designs.

I will keep the Board apprised of the FAA's progress on these safety recommendations.

Sincerely,

Thomas C. Richards
Administrator

JAN -6 1993

Honorable Thomas C. Richards
 Administrator
 Federal Aviation Administration
 Washington, D.C. 20591

Dear Mr. Richards:

Thank you for your letter dated October 26, 1992, responding to Safety Recommendations A-92-81 through -83. These recommendations resulted from the Board's investigation of an accident involving a Mitsubishi MU-2B-60 airplane that sustained damage when one of the four Hartzell propeller blades on the right engine separated in flight near Utica, New York, on September 27, 1991.

The Safety board found that loss of the propeller blade was the result of fatigue cracking that initiated from the inside diameter surface of one of the arms of the HC-B4 Hartzell propeller hub. Safety Recommendation A-92-81 asked the FAA to develop, with Hartzell's assistance, an inspection method capable of detecting hub arm cracks and to issue an airworthiness directive (AD) requiring that HC-B4 hubs with over 3,000 hours be inspected. Safety Recommendation A-92-82 asked the FAA to mandate repeated inspections of the affected hubs, if so warranted by the results of the initial inspections. Safety Recommendation A-92-83 asked the FAA to determine if other similarly designed Hartzell propeller hubs should also be inspected for cracking.

The Safety Board notes that the FAA is reviewing the service history of the Hartzell propeller hubs to determine the magnitude of the problem. Regardless of whether the service history of the HC-B4 hubs contains other examples of cracking or fractures similar to the Utica accident, the Safety Board believes that a once-through-the-fleet inspection of the subject hubs is necessary, as requested in Safety Recommendation A-92-81. Because your letter does not indicate that the FAA has taken any steps toward this action, the Board has classified Safety Recommendation A-92-81 "Open--Unacceptable Response." Also, because implementation of Safety Recommendation A-92-82 must be preceded by a once-through-the-fleet inspection of the HC-B4 hubs, this recommendation is also classified "Open--Unacceptable Response."

The Safety Board believes that a review of the design and fabrication process similarities between the HC-B4 and other Hartzell propeller hub models is necessary, as requested in Safety Recommendation A-92-83, to determine if other Hartzell propeller hub models should also be inspected. Because your letter does not adequately address this issue, the Board has classified Safety Recommendation A-92-83 "Open--Unacceptable Response."

The Safety Board urges the FAA to reconsider the actions planned in response to Safety Recommendations A-92-81 through -83.

Sincerely,

Original Signed by
Carl W. Vogt

Carl W. Vogt
Chairman

cc: Mr. Donald R. Trilling
Director
Office of Transportation Regulatory Affairs



U.S. Department
of Transportation
Federal Aviation
Administration

108

Office of the Administrator

800 Independence Ave., S.W.
Washington, D.C. 20591

OCT 26 1992

The Honorable Carl W. Vogt
Chairman, National Transportation
Safety Board
490 L'Enfant Plaza East, SW
Washington, DC 20594

Dear Mr. Chairman:

This is in response to Safety Recommendations A-92-81 through -83 issued by the Board on August 13, 1992. These safety recommendations were issued as a result of the Board's investigation of an accident on September 27, 1991, involving a Mitsubishi MU-2B-60, Canadian registry C-PFSS, which was on a cargo flight. The airplane sustained substantial damage when a propeller blade separated in flight near Utica, New York. The airplane was climbing through flight level 190 when the pilot felt a strong vibration, followed shortly by a loud "bang." The vibration increased and became so severe that the pilot experienced considerable difficulty controlling the airplane. Despite this difficulty, the airplane landed at Utica Airport. There were no injuries,

A-92-81. Develop, with the assistance of Hartzell Propeller, Incorporated, a nondestructive inspection technique capable of detecting hub arm cracks stemming from the inside diameter surface of the hub arm at the approximate location of the inserted end of the pilot tubes on Hartzell model HC-B4 propeller hubs, and issue an airworthiness directive requiring that HC-B4 hubs with 3,000 hours or more be inspected using this technique the next time the propeller assembly is overhauled for any reason, or at the next annual inspection (or equivalent), whichever is first.

-82. Determine, based on the results of the inspections requested in Safety Recommendation A-92-81, if the hub arms on Hartzell model HC-B4 propeller hubs with 3,000 hours or more should be inspected at periodic intervals. If such inspections are warranted, issue an airworthiness directive, as appropriate, requiring periodic inspections.

A-92-83. Determine if Hartzell model HC-B3 and -B5 propeller hubs, based on similarity of design and fabrication processes with the HC-B4 propeller hub, should be inspected for cracking

in the hub arms. If such inspections are warranted, issue an airworthiness directive, as appropriate, requiring periodic inspections.

FAA Comment. The Federal Aviation Administration (FAA) is reviewing the service history of the Hartzell Propeller *hubs* to determine the magnitude of the problem. The FAA is also reviewing the service manuals to determine what, if any, changes need to be made.

I will apprise the Board of the FAA's course of action to address these safety recommendations as soon as the review is completed.

Sincerely,



Thomas C. Richards
Administrator



National Transportation Safety Board

Washington, D.C. 20594

Safety Recommendation

Date: August 13, 1992

In reply refer to: A-92-81 through -83

Honorable Thomas C. Richards
 Administrator
 Federal Aviation Administration
 Washington, D.C. 20591

On September 27, 1991, a Hitsubishi MU-2B-60, Canadian registry C-FFSS, on a cargo night, sustained substantial damage when a propeller blade separated in flight near Utica, New York. The airplane was climbing through 19,000 feet when the pilot felt a strong vibration, followed shortly by a loud "bang." The vibration increased and became so severe that tire pilots experienced considerable difficulty controlling the airplane. Despite this difficulty, the airplane was successfully landed at the Utica airport, with no injuries.

Postaccident examination of the airplane revealed that one of the four arms of the propeller hub for the No. 2 engine had separated, releasing one of the four propeller blades in flight. The released blade hit and damaged an adjacent blade on the same engine and ripped a 12-inch hole in the pressurized portion of the fuselage. The severe vibration resulting from loss of the blade caused substantial twisting and wrinkling of the wings and a partial reparation of the No. 2 engine nacelle from the engine truss mounts. The released blade and associated blade clamp, pilot tube, and separated portion of the hub have not been recovered.

Metallurgical examination of the broken Hartzell propeller hub, model HC-B4TN-SDL, was conducted at the Safety Board's materials laboratory. The hub a n fracture was located about 2.3 inches inboard of the outboard end of the hub arm. The fracture was caused by a fatigue crack that initiated from multiple sites on the inside diameter surface of the arm and progressed through 70 percent of the arm cross section before final separation. The fatigue crack initiation area was approximately in line with the inboard end of the pilot tube; tha: is assembled into the hub arm bore with an interference fit. During operation of the propeller, a slight stress increase is expected to occur at the position corresponding to the assembled inboard end of the pilot tube, and this may have caused the fatigue origin area to be located at this radial position.

The inside diameter surface of the separated hub arm contained scratch marks that extended over about one-half of the hole wall circumference and from the fracture surface to a position slightly inboard of the plane of the fracture. The fatigue origin area was located within this area of scratches.

Examination of the three remaining intact arms after removal of the pilot tubes disclosed evidence of scratch marks similar to those found on the separated arm.

As the propeller rotates, the predominant load experienced by the hub arm is from the centrifugal loads on the propeller blades. These loads result in radial-tension throughout the hub arm. In addition, drag and thrust loads on the blades produce bending in the hub arms. During normal operation (in forward propeller thrust), these bending loads result in maximum tension in the aft leading-edge quadrant of the hub arm. During reverse thrust, the maximum tension would be in the forward leading-edge quadrant of the hub arm. However, the fatigue origin area was not located in either of these quadrants, but was, instead, found in the forward trailing-edge quadrant of the hub arm, suggesting that the circumferential location of the fatigue initiation region was not influenced by bending loads but may have been determined by local stress raisers such as the scratches on the inside diameter surface of the separated hub arm.

The separated propeller hub was manufactured in 1977 and was overhauled in 1983 and 1988. Records from the first overhaul are not available. The records from the second overhaul indicate that two of the four pilot tubes had been replaced at that time. Because similar scratches were found on all four hub arms, it is unlikely that the scratches were introduced during the more recent overhaul. Also, the scratches extended inboard of the position contacted by the pilot tubes, and it is unlikely that removal or insertion of the tubes could create such damage. However, the scratches could have been created by some manufacturing or repair process any time that the pilot tubes were not present in the hub arms. The Safety Board believes it more likely that scratches were produced during original manufacturing of the hub.

General corrosion damage and corrosion pitting were also noted on various portions of the inside diameter surface of the remaining portion of the separated hub arm, including the area from which the fatigue cracking initiated. The general corrosion damage had partially obliterated the scratches from the inside diameter surface. Scanning electron microscopic examination of the fracture revealed no evidence of corrosion pits at the individual fatigue initiation sites, indicating that corrosion may not have substantially contributed to initiation of the fatigue cracking.

The Safety Board believes that it is more likely that the fatigue cracking on the separated hub initiated from the scratches than from corrosion damage. Regardless of the cause of initiation, the failure of a hub arm on a HC-B4 propeller hub could result in a catastrophic accident.

The separated hub, model HC-B4TN-5DL, had accumulated a total of 4,432 hours of operation since new. Information provided by Hartzell indicated that the highest time model HC-B4 propeller hub (manufactured since the 1960s) has accumulated about 15,000 hours of operation. The Safety Board believes that all HC-B4 Hartzell propeller hubs that have accumulated at least 3,000 hours should be subjected to a one-time inspection for cracks.

Hartzell recommends that the HC-B4 propeller be overhauled every 5 years or 3,000 hours, whichever comes first. Performing the hub inspection at the next recommended overhaul could allow passage of too much time before the inspection is performed. Therefore, the Safety Board believes that the hubs should be inspected the next time that the propeller assembly is overhauled, or at the next annual inspection (or equivalent), whichever occurs first. If the inspection of these hubs reveals additional hubs with cracks, then periodic inspections of the HC-B4 hubs may also be necessary.

The Interference fit between the pilot tube and the hub arm increases the possibility that removal and reassembly of the pilot tubes (to do a direct inspection of the inside diameter surface of the hub arms) could damage the hole wall. However, the Safety Board believes that hub arm cracks could be detected without removal of the pilot tubes through the use of an inspection method such as ultrasonic inspection.

The design of the HC-B4 hub and the manufacturing processes used to make it are very similar to the design and processes used to make the Hartzell three-bladed hub (basic model HC-B3) and the Hartzell five-bladed hub (HC-B5). Hartzell has made more than 27,000 three-bladed hubs and more than 1,300 five-bladed hubs. Because of the similarities between the types of hubs, the Safety Board is concerned that hubs of the three- and five-bladed design could also be susceptible to cracking because they could have damage similar to the scratch marks and corrosion found on the separated four-bladed hub. A failure of a hub arm on a three- or five-bladed hub could also result in a catastrophic accident, and the Safety Board believes that inspections of these hubs may also be necessary to determine if they have a cracking problem.

Therefore, the National Transportation Safety Board recommends that the Federal Aviation Administration:

Develop, with the assistance of Hartzell Propeller, Incorporated, a nondestructive inspection technique capable of detecting hub arm cracks stemming from the inside diameter surface of the hub arm at the approximate location of the inserted end of the pilot tubes on Hartzell model HC-B4 propeller hubs, and issue an airworthiness directive requiring that HC-B4 hubs with 3,000 hours or more be inspected using this technique the next time the propeller assembly is overhauled for any reason, or at the next annual inspection (or equivalent), whichever is first. (Class II, Priority Action) (A-92-81)

Determine, based on the results of the inspections requested in Safety Recommendation A-92-81, if the hub arms on Hartzell model HC-B4 propeller hubs with 3,000 hours or more should be inspected at periodic intervals. If such inspections are warranted, issue an airworthiness directive, as appropriate, requiring periodic inspections. (Class II, Priority Action) (A-92-82)

Determine if Hartzell model HC-83 and -85 propeller hubs, based on similarity of design and fabrication processes with the HC-84 propeller hub, should be inspected for cracking in the hub arms. If such inspections are warranted, issue an airworthiness directive, as appropriate, requiring periodic inspections. (Class II, Priority Action) (A-92-83)

Chairman VOGT, Vice Chairman COUGHLIN, and Members LAUBER, HART, and HAMMERSCHMIDT concurred in these recommendations.



By: Carl W. Vogt
Chairman

APPENDIX D

ATC HANDBOOK 7110.65H, EMERGENCY ASSISTANCE

Section 2. EMERGENCY ASSISTANCE

10-10 INFORMATION REQUIREMENTS

a. Start assistance as soon as enough information has been obtained upon which to act. Information requirements will vary, depending on the existing situation. Minimum required information for in-flight emergencies is:

10-10a Note.—In the event of an ELT signal see paragraph 10-19.

1. Aircraft identification and type.
2. Nature of the emergency.
3. Pilot's desires.

b. After initiating action, obtain the following items or any other pertinent information from the pilot or aircraft operator, as necessary:

10-10b Note.—Normally, do not request this information from military fighter-type aircraft that are at low altitudes (i.e. on approach, immediately after departure, on a low level route, etc.). However, request the position of an aircraft that is not visually sighted or displayed on radar if the pilot has not given his location.

1. Aircraft altitude.
2. Fuel remaining in time.
3. Pilot reported weather.
4. Pilot capability for IFR flight.
5. Time and place of last known position.
6. Heading since last known position.
7. Airspeed.
8. Navigation equipment capability.
9. NAVAID signals received.
10. Visible landmarks.
11. Aircraft color.
12. Number of people on board.
13. Point of departure and destination.
14. Emergency equipment on board.

10-11 FREQUENCY CHANGES

Although 121.5 MHz and 243.0 MHz are emergency frequencies, it might be best to keep the aircraft on the initial contact frequency. Change frequencies only when there is a valid reason.

10-12 AIRCRAFT ORIENTATION

Orientate an aircraft by the means most appropriate to the circumstances. Recognized methods include:

- a. Radar.
- b. DF.
- c. NAVAID's.
- d. Pilotage.

e. Sighting by other aircraft.

10-13 ALTITUDE CHANGE FOR IMPROVED RECEPTION

When you consider it necessary and if weather and circumstances permit, recommend that the aircraft maintain or increase altitude to improve communications, radar, or DF reception.

10-14 EMERGENCY SITUATIONS

Consider that an aircraft emergency exists and inform the RCC or ARTCC and alert the DF Net when:

10-14 Note 1.—USAF facilities are only required to notify the ARTCC.

10-14 Note 2.—Each ARTCC shall be the DF Net Control for its flight advisory area except Washington ARTCC. The Norfolk RCC is the DF Net Control for the Washington flight advisory area.

a. An emergency is declared by either:

1. The pilot.
2. Facility personnel.

10-14a2 Note.—An example of an emergency which should be declared by facility personnel is unexpected loss of radar contact and radio communications with an aircraft.

3. Officials responsible for the operation of the aircraft.

b. Reports indicate it has made a forced landing, is about to do so, or its operating efficiency is so impaired that a forced landing will be necessary.

c. Reports indicate the crew has abandoned the aircraft or is about to do so.

d. An emergency radar beacon response is received.

10-14d Note.—EN ROUTE: During Stage A operation, Code 7700 causes EMRG to blink in field E of the data block.

e. Intercept or escort aircraft services are required.

f. The need for ground rescue appears likely.

g. An Emergency Locator Transmitter (ELT) signal is heard or reported.

10-14g Reference.—Providing Assistance, paragraph 10-3. Emergency Locator Transmitter (ELT) Signals, paragraph 10-19.

10-15 HIJACKED AIRCRAFT

When you observe a Mode 3/A Code 7500, do the following:

10-15 Note 1.—Military facilities will notify the appropriate FAA ARTCC, or the host nation agency responsible for en route control, of any indication that an aircraft is being hijacked. They

7110.65H

9/16/93

will also provide full cooperation with the civil agencies in the control of such aircraft.

10-15 Note 2.— *EN ROUTE*: During narrowband radar operations, Code 7500 causes HJK to blink in the data block.

10-15 Note 3.—Only nondiscrete Code 7500 will be decoded as the hijack code.

a. Acknowledge and confirm receipt of Code 7500 by asking the pilot to verify it. If the aircraft is not being subjected to unlawful interference, the pilot should respond to the query by broadcasting in the clear that he is not being subjected to unlawful interference. If the reply is in the affirmative or if no reply is received, do not question the pilot further but be responsive to the aircraft requests.

Phraseology:

(Identification) (name of facility) VERIFY SQUAWKING 7500.

10-15a Note.—Code 7500 is only assigned upon notification from the pilot that his aircraft is being subjected to unlawful interference. Therefore, pilots have been requested to refuse the assignment of Code 7500 in any other situation and to inform the controller accordingly.

b. Notify supervisory personnel of the situation.

c. Flight follow aircraft and use normal handoff procedures without requiring transmissions or responses by aircraft unless communications have been established by the aircraft.

d. If aircraft are dispatched to escort the hijacked aircraft, provide all possible assistance to the escort aircraft to aid in placing them in a position behind the hijacked aircraft.

10-15d Reference.—Escort procedures are contained in Order 7610.4, Chapter 7.

e. To the extent possible, afford the same control service to the aircraft operating VFR observed on the hijack code.

10-15 Reference.—Code Monitor, paragraph 5-33.

10-16 VFR AIRCRAFT IN WEATHER DIFFICULTY

a. If VFR aircraft requests assistance when it encounters or is about to encounter IFR weather conditions, request the aircraft to contact the appropriate control facility. Inform that facility of the situation. If the aircraft is unable to communicate with the control facility, relay information and clearances.

b. The following shall be accomplished on a Mode C equipped VFR aircraft which is in emergency but no longer requires the assignment of code 7700:

1. **TERMINAL**: Assign a beacon code that will permit terminal minimum safe altitude warning (MSAW) alarm processing.

2. **EN ROUTE**: An appropriate keyboard entry shall be made to ensure en route MSAW (EMSAW) alarm processing.

10-17 RADAR ASSISTANCE TO VFR AIRCRAFT IN WEATHER DIFFICULTY

a. If a VFR aircraft requests radar assistance when it encounters or is about to encounter IFR weather conditions, ask the pilot if he is qualified for and capable of conducting IFR flight.

b. If the pilot states he is qualified for and capable of IFR flight, request him to file an IFR flight plan and then issue clearance to destination airport, as appropriate.

c. If the pilot states he is not qualified for or not capable of conducting IFR flight, or if he refuses to file an IFR flight plan, take whichever of the following actions is appropriate:

1. Inform the pilot of airports where VFR conditions are reported, provide other available pertinent weather information, and ask if he will elect to conduct VFR flight to such an airport.

2. If the action in subparagraph 10-17c1 is not feasible or the pilot declines to conduct VFR flight to another airport, provide radar assistance if the pilot:

(a) Declares an emergency.

(b) Refuses to declare an emergency and you have determined the exact nature of the radar services the pilot desires.

3. If the aircraft has already encountered IFR conditions, inform the pilot of the appropriate terrain/obstacle clearance minimum altitude. If the aircraft is below appropriate terrain/obstacle clearance minimum altitude and sufficiently accurate position information has been received or radar identification is established, furnish a heading or radial on which to climb to reach appropriate terrain/obstacle clearance minimum altitude.

d. The following shall be accomplished on a Mode C equipped VFR aircraft which is in emergency but no longer requires the assignment of code 7700:

1. **TERMINAL**: Assign a beacon code that will permit terminal minimum safe altitude warning (MSAW) alarm processing.

2. **EN ROUTE**: An appropriate keyboard entry shall be made to ensure en route MSAW (EMSAW) alarm processing.

10-18 RADAR ASSISTANCE TECHNIQUES

Use the following techniques to the extent possible when you provide radar assistance to a pilot not qualified to operate in IFR conditions:

9/16/93

7110.65H

- a. Avoid radio frequency changes except when necessary to provide a clear communications channel.
- b. Make turns while the aircraft is in VFR conditions so it will be in a position to fly a straight course while in IFR conditions.
- c. Have pilot lower gear and slow aircraft to approach speed while in VFR conditions.
- d. Avoid requiring a climb or descent while in a turn if in IFR conditions.
- e. Avoid abrupt maneuvers.
- f. Vector aircraft to VFR conditions.
- g. The following shall be accomplished on a Mode C equipped VFR aircraft which is in emergency but no longer requires the assignment of code 7700:

1. **TERMINAL:** Assign a beacon code that will permit terminal minimum safe altitude warning (MSAW) alarm processing.

2. **EN ROUTE:** An appropriate keyboard entry shall be made to ensure en route MSAW (EMSAW) alarm processing.

10-19 EMERGENCY LOCATOR TRANSMITTER (ELT) SIGNALS

When an ELT signal is heard or reported

a. **EN ROUTE:** Notify the Rescue Coordination Center (RCC).

10-19a Note.—FAA Form 7210-8, ELT Incident, contains standardized format for coordination with the RCC.

10-19a Reference.—Order 7210.3, paragraph 11-30.

b. **TERMINAL:** Notify the ARTCC which will coordinate with the Rescue Coordination Center (RCC).

10-19a, and b Note 1.—Operational ground testing of Emergency Locator Transmitters (ELT's) has been authorized during the first 5 minutes of each hour. To avoid confusing the tests with an actual alarm, the testing is restricted to no more than three audio sweeps.

10-19a, and b Note 2.—Controllers can expect pilots to report aircraft position and time the signal was first heard, aircraft position and time the signal was last heard, aircraft position at maximum signal strength, flight altitude, and frequency of the emergency signal (121.5/243.0). (See Airman's Information Manual, Emergency Locator Transmitters, paragraph 6-15.)

c. **EN ROUTE:** Request DF Net attempt to obtain fixes or bearings on signal. Forward bearings or fixes obtained plus any other pertinent information to the RCC.

d. **TERMINAL:** Attempt to obtain fixes or bearings on the signal.

e. Solicit the assistance of other aircraft known to be operating in the signal area.

f. **TERMINAL:** Forward fixes or bearings and any other pertinent information to the ARTCC.

10-19f Note.—Fix information in relation to a VOR or VORTAC (radial-distance) facilitates accurate ELT plotting by RCC and should be provided when possible.

g. **EN ROUTE:** When the ELT signal strength indicates the signal may be emanating from somewhere on an airport or vicinity thereof, notify the on-site Airway Facilities personnel and the Regional Operations Center (ROC) for their actions. This action is in addition to the above.

h. **TERMINAL:** When the ELT signal strength indicates the signal may be emanating from somewhere on the airport or vicinity thereof, notify the on-site Airway Facilities personnel and the ARTCC for their action. This action is in addition to the above.

i. Air Traffic personnel shall not leave their required duty stations to locate an ELT signal source.

10-19h and i Note.—Portable handcarried receivers assigned to air traffic facilities (where no Airway Facilities personnel are available) may be loaned to responsible airport personnel or local authorities to assist in locating the ELT signal source.

j. **EN ROUTE:** Notify the RCC, the ROC, and deactivate the DF net if signal source is located/terminated.

k. **TERMINAL:** Notify the ARTCC if signal source is located/terminated.

10-19 Reference.—Responsibility, paragraph 10-4. Information Requirements, paragraph 10-10.

10-20 AIRCRAFT BOMB THREATS

a. When information is received from any source that a bomb has been placed on, in, or near an aircraft for the purpose of damaging or destroying such aircraft, notify your supervisor or the facility air traffic manager. If the threat is general in nature, handle it as a "Suspicious Activity." When the threat is targeted against a specific aircraft and you are in contact with the suspect aircraft, take the following actions as appropriate:

10-20a Note 1.—Facility supervisors are expected to notify the appropriate offices, agencies, operators/air carriers according to applicable plans, directives, and Order 7210.3, paragraph 2-8 or applicable military directives.

10-20a Note 2.—"Suspicious Activity" is covered in Order 7210.3, paragraph 2-85. Military facilities would report a "general" threat through the chain of command or according to service directives.

1. Advise the pilot of the threat.

2. Inform the pilot that technical assistance can be obtained from an FAA Aviation Explosives Expert.

10-20a2 Note.—An FAA Aviation Explosive Expert is on call at all times and may be contacted by calling the FAA Operations Center, Washington, DC, area code 202-863-5100, FTS 989-5100, ETN 521-0111, or DSN 667-5592. Technical advice can be relayed to assist civil or military air crews in their search.

for a bomb and in determining what precautionary action to take if one is found.

3. Ask the pilot if he desires to climb or descend to an altitude that would equalize or reduce the outside air pressure/existing cabin air pressure differential. Issue or relay an appropriate clearance considering MEA, MOCA, MRA, and weather.

10-20a3 Note.—Equalizing existing cabin air pressure with a t-ride air pressure is a key step which a pilot may wish to take to minimize the damage potential of a bomb.

4. Handle the aircraft as an emergency and/or provide the most expeditious handling possible with respect to the safety of other aircraft, ground facilities, and personnel.

10-20a4 Note.—Emergency handling is discretionary and should be based on the situation with certain types of threats, plans may call for a low-key action or response.

5. Issue or relay clearances to a new destination if requested.

6. When a pilot requests technical assistance or if it is apparent that a pilot may need such assistance, do NOT suggest what actions the pilot should take concerning a bomb, but obtain the following information and notify your supervisor who will contact the FAA Aviation Explosives Expert:

10-20a6 Note.—This information is needed by the FAA Aviation Explosives Expert so that he can assess the situation and make immediate recommendations to the pilot. The Aviation Explosives Expert may not be familiar with all military aircraft configurations but he can offer technical assistance which would be beneficial to the pilot.

(a) Type, series, and model of the aircraft.

(b) Precise location/description of the bomb device if known.

(c) Other details which may be pertinent.

10-20a6(c) Note.—The following details may be of significance if known, but it is not intended that the pilot should disturb a suspected bomb/bomb container to ascertain the information: the altitude or time set for the bomb to explode, type of detonating action (barometric, time, anti-handling, remote radio transmitter), power source (battery, electrical, mechanical), type of initiator (blasting cap, flash bulb, chemical), and the type of explosive/incendiary charge (dynamite, black powder, chemical).

b. When a bomb threat involves an aircraft on the ground and you are in contact with the suspect aircraft, take the following actions in addition to those discussed in the preceding paragraph which may be appropriate:

1. If the aircraft is at an airport where tower control or FSS advisory service is not available, or if the pilot ignores the threat at any airport, recommend that takeoff be delayed until the pilot or aircraft operator establishes that a bomb is not aboard in accordance with FAR 121. If the pilot insists on taking off and in your opinion

the operation will not adversely affect other traffic, issue or relay an ATC clearance.

10-20b1 Reference.—Aircraft Security, FAR 121.538.

2. Advise the aircraft to remain as far away from other aircraft and facilities as possible, to clear the runway, if appropriate, and to taxi to an isolated or designated search area. When it is impractical or if the pilot takes an alternative action; e.g., parking and off-loading immediately, advise other aircraft to remain clear of the suspect aircraft by at least 100 yards if able.

10-20b2 Note.—Passenger deplaning may be of paramount importance and must be considered before the aircraft is parked or moved away from service areas. The decision to use ramp facilities rests with the pilot, aircraft operator/airport manager.

c. If you are unable to inform the suspect aircraft of a bomb threat or if you lose contact with the aircraft, advise your supervisor and relay pertinent details to other sectors or facilities as deemed necessary.

d. When a pilot reports the discovery of a bomb or suspected bomb on an aircraft which is airborne or on the ground, determine the pilot's intentions and comply with his requests in so far as possible. Take all of the actions discussed in the preceding paragraphs which may be appropriate under the existing circumstances.

e. The handling of aircraft when a hijacker has or is suspect of having a bomb requires special considerations. Be responsive to the pilot's requests and notify supervisory personnel. Apply hijacking procedures and offer assistance to the pilot according to the preceding paragraphs, if needed.

10-21 EXPLOSIVE DETECTION K-9 TEAMS

Take the following actions should you receive an aircraft request for the location of the nearest explosive detection K-9 team.

10-21 Reference.—Order 72103, Explosives Detection K-9 Teams, paragraph 2-10.

a. Obtain the aircraft identification and position and advise your supervisor of the pilot request.

b. When you receive the nearest location of the explosive detection K-9 team, relay the information to the pilot.

c. If the aircraft wishes to divert to the airport location provided, obtain an estimated arrival time from the pilot and advise your supervisor.

10-22 EMERGENCY AIRPORT RECOMMENDATION

Consider the following factors when recommending an emergency airport:

a. Remaining fuel in relation to airport distances.

b. Weather conditions.

c. Airport conditions.

9/16/93

7110.65H

- d. NAVAID status.
- e. Aircraft type.
- f. Pilot's qualifications.
- g. Vectoring or homing capability to the emergency airport.

10-23 GUIDANCE TO EMERGENCY AIRPORT

When necessary, use any of the following for guidance to the airport:

- a. Radar.
- b. DF.
- c. Following another aircraft.
- d. NAVAID's.
- e. Pilotage by landmarks.
- f. Compass headings.

10-24 EMERGENCY OBSTRUCTION VIDEO MAP (EOVM)

a. The EOVM is intended to facilitate advisory service to an aircraft in an emergency situation wherein an appropriate terrain/obstacle clearance

minimum altitude cannot be maintained. It shall only be used and the service provided under the following conditions:

1. The pilot has declared an emergency, or
2. The controller has determined that an emergency condition exists or is imminent because of the pilot's inability to maintain an appropriate terrain/obstacle clearance minimum altitude.

10-24a2 Note.—Appropriate terrain/obstacle clearance minimum altitudes may be defined as Minimum IFR Altitude (MIA), Minimum En route Altitude (MEA), Minimum Obstruction Clearance Altitude (MOCA), or Minimum Vectoring Altitude (MVA).

b. When providing emergency vectoring service, the controller shall advise the pilot that any headings issued are emergency advisories intended only to direct the aircraft toward and over an area of lower terrain/obstacle elevation.

10-24b Reference.—Order 7210.3, Emergency Obstruction Video Map Order, paragraph 3-103.

10-25 thru 10-29 RESERVED

APPENDIX E

HAWTZELL PROPELLER AIRWORTHINESS DIRECTIVES

AIRWORTHINESS DIRECTIVE

FLIGHT STANDARDS SERVICE
REGULATORY SUPPORT DIVISION
P.O. BOX 26460
OKLAHOMA CITY, OKLAHOMA 73125-0460

U.S. Department
of Transportation
Federal Aviation
Administration

The following Airworthiness Directive issued by the Federal Aviation Administration in accordance with the provisions of Federal Aviation Regulations, Part 39, applies to an aircraft model of which our records indicate you may be the registered owner. Airworthiness Directives affect aviation safety and are regulations which require immediate attention. You are cautioned that no person may operate an aircraft to which an Airworthiness Directive applies, except in accordance with the requirements of the Airworthiness Directive (reference FAR Subpart 39.3).

93-12-01 Hartzell Propeller, Inc.: Amendment 39-8642. Docket 93-ANE-35.

Applicability: Hartzell Propeller, Inc. Model HC-B4TN-5(D,G,JL)/LT10282(B,K)-5.3R and HC-B4TN-5(D,G,JL)/LT10282N(B,K)-5.3R propellers installed on Mitsubishi Model MU-2B-26A, -36A, and -40 aircraft.

Compliance: Required as indicated, unless accomplished previously.

To prevent possible fatigue *cracks* in propeller hub arm assemblies progressing to failure, resulting in departure of the hub arm and blade, that may result in *engine* separation and subsequent loss of aircraft control, accomplish the following in accordance with the compliance schedule as indicated:

**TIME-SINCE-NEW (TSN)
IN HOURS ON THE EFFECTIVE
DATE OF THIS AD OR PROPELLER
HUB ASSEMBLIES THAT HAVE
EXPERIENCED A BLADE STRIKE**

TSN greater than or equal to
3000 hours or TSN unknown.

TSN less than 3000 hours.

COMPLIANCE REQUIRED

Within the next 10 hours time in service (TIS) or two calendar months after the effective date of *this AD*, whichever occurs first, and thereafter at intervals not to exceed 600 hours TIS or 60 calendar months since last inspection, whichever occurs first.

Prior to the accumulation of 3010 hours TSN, or within the next 200 hours TIS or 12 months after the effective date of *this AD*, whichever occurs first, and thereafter at intervals not to exceed 600 hours TIS or 60 calendar months since last inspection, whichever occurs first.

2 93-12-01

**TIME-SINCE-NEW (TSN)
IN HOURS ON THE EFFECTIVE
DATE OF THIS AD OR PROPELLER
HUB ASSEMBLIES THAT HAVE
EXPERIENCED A BLADE STRIKE**

Regardless of TSN,
propeller hub assemblies
that have experienced a
blade strike prior
to the effective date of
this AD. See paragraph (c)
of this AD for the
definition of a blade
strike

Regardless of TSN,
propeller hub assemblies
that experience a
blade strike after the
effective date of this
AD. See paragraph (c) of
this AD for the definition of
a blade strike.

COMPLIANCE REQUIRED

Within the next 10 hours
TIS or two calendar
months after the
effective date of this
AD whichever occurs
first and thereafter
at intervals not to
exceed 600 hours
TIS or 60 calendar
months since last
inspection, whichever
occurs first.

Prior to further flight,
and thereafter at
intervals not to exceed
600 hours TIS or 60
calendar months since
last inspection,
whichever occurs first.

(a) Remove affected propeller hub assemblies from the aircraft and return to Hartzell Propeller Inc., One Propeller Place, Piqua, OH 45356-2634 U.S.A. for inspection and specified rework procedures. In accordance with Hartzell Alert Service Bulletin (ASB) No. A183, dated June 1, 1993. Propeller hubs removed from Mitsubishi Model MU-2B-26A, -36A, and -40 aircraft may not be installed on any other aircraft unless an inspection is performed in accordance with Hartzell ASB No. A183, dated June 1, 1993.

(b) Re-install affected propeller hub assemblies that have had the hub arm bores inspected and reworked as necessary, pilot tubes replaced, and marked at the end of the hub serial number with suffix letter "M", followed by a number (1,2,3, etc.) to indicate the number of repetitive inspections performed in accordance with Hartzell ASB No. A183, dated June 1, 1993 or Install new production hubs which have passed the inspection and have been marked at the end of the hub serial number with the suffix letter "M".

(c) A blade strike is defined as a propeller having any blade(s) that has been bent beyond repair limits in accordance with Hartzell Service Letter 61R, dated February 28, 1992.

(d) The "calendar month" compliance time stated in this AD allow the performance of the required action prior to the last day of the month in which compliance is required.

NOTE: For example, if action is required 2 calendar months from June 15, 1993, the required actions are to be performed not later than August 31, 1993.

(e) An alternate method of compliance or adjustment of the compliance time that provides an acceptable level of safety may be used if approved by the Manager, Chicago Aircraft Certification Office. The request should be forwarded through an appropriate FAA Maintenance Inspector, who may add comments and then send it to the Manager, Chicago Aircraft Certification Office.

NOTE 1: Information concerning the existence of approved alternative methods of compliance with this Airworthiness Directive, if any, may be obtained from Chicago Aircraft Certification Office.

NOTE 2: Although Hartzell Propeller is presently the only FAA-approved repair facility authorized to conduct the requirements of this AD, other facilities may be authorized through the alternative method of compliance procedure in paragraph (e) of this AD.

(f) Except when propeller hub assemblies experience a blade strike after the effective date of this AD, special flight permits may be issued in accordance with FAR 21.197 and 21.199 to operate the airplane to a location where the requirements of this AD can be accomplished.

(g) The removal from service, inspection, rework, and reinstallation shall be done in accordance with the following alert service bulletin:

Document No.	Pages	Revision	Date
Hartzell ASB No. A183	1-3	Original	June 1, 1993

Total pages: 3

This incorporation by reference was approved by the Director of the Federal Register in accordance with 5 U.S.C. 552(a) and 1 CFR part 51. Copies may be obtained from Hartzell Propeller Inc., One Propeller Place, Piqua, OH 45353-2634. Copies may be inspected at the FAA, New England Region, Office of the Assistant Chief Counsel, 12 New England Executive Park Burlington, MA; or at the Office of the Federal Register, 800 North Capitol Street, NW., suite 700, Washington, DC.

(h) This amendment becomes effective October 14, 1993, to all persons except those persons to whom it was made immediately effective by priority letter AD 93-12-01, issued June 10, 1993, which contained the requirements of this amendment.

FOR FURTHER INFORMATION CONTACT

Tim Smyth, Aerospace Engineer, Chicago Aircraft Certification Office, FAA, Small Airplane Directorate, 2300 East Devon Avenue, Room 232, Des Plaines, IL 60018; telephone (312) 694-7130, fax (312) 694-7834.

AIRWORTHINESS DIRECTIVE

**FLIGHT STANDARDS SERVICE
REGULATORY SUPPORT DIVISION
P.O. BOX 26460
OKLAHOMA CITY, OKLAHOMA 73125-0460**

**U.S. Department
of Transportation
Federal Aviation
Administration**

The following Airworthiness Directive issued by the Federal Aviation Administration in accordance with the provisions of Federal Aviation Regulations, Part 39, applies to an aircraft model of which our records indicate you may be the registered owner. Airworthiness Directives affect aviation safety and are regulations which require immediate attention. You are cautioned that no person may operate an aircraft to which an Airworthiness Directive applies, except in accordance with the requirements of the Airworthiness Directive (reference FAR Subject 39.3).

93-09-04 Hartzell Propeller Inc.: Amendment 39-8583. Docket 93-ANE-25.

Applicability: Hartzell Propeller Inc. HC-B4TN-5(D.G.J)L/LT10282(B,K)-5.3R and HC-B4TN-5(D.G.J)L/LT10282N(B,K)-5.3R Propellers installed on Mitsubishi Model MU-2B-60 Aircraft.

NOTE: The parentheses indicate the presence or absence of an additional letter(s) which vary the basic propeller hub and blade model designation. This Airworthiness Directive (AD) still applies regardless of whether these letters are present or absent on the propeller hub and blade model designation.

Compliance: Required as indicated, unless accomplished previously.

To prevent fatigue cracks in propeller hub arm assemblies progressing to failure, resulting in departure of the hub arm and blade, and that may result in engine separation and subsequent loss of aircraft control, accomplish the following in accordance with the compliance schedule as indicated:

**TIME-SINCE-NEW (TSN)
IN HOURS ON THE EFFECTIVE
DATE OF THIS AD OR PROPELLER
HUB ASSEMBLIES THAT HAVE
EXPERIENCED A BLADE STRIKE**

COMPLIANCE REQUIRED

TSN greater than or equal to
3000 hours or TSN unknown.

Within the next 10 hours
time in service (TIS) or
two calendar months after
the effective date of
this AD, whichever occurs
first, and thereafter at
intervals not to exceed
600 hours TIS or 60
calendar months since
last inspection,
whichever occurs first.

TSN less than 3000 hours.

Prior to the accumulation
of 3010 hours TSN, or
within the next 200 hours
TIS or 12 months after
the effective date of
this AD, whichever occurs
first, and thereafter at
intervals not to exceed
600 hours TIS or 60
calendar months since
last inspection,
whichever occurs first.

2 93-09-04

**TIME-SINCE-NEW (TSN)
IN HOURS ON THE EFFECTIVE
DATE OF THIS AD OR PROPELLER
HUB ASSEMBLIES THAT HAVE
EXPERIENCED A BLADE STRIKE**

Regardless of TSN, propeller hub assemblies that have experienced a blade strike prior to the effective date of this AD. See paragraph (c) of this AD for the definition of a blade strike

Regardless of TSN, propeller hub assemblies that experience a blade strike after the effective date of this AD. See paragraph (c) of this AD for the definition of a blade strike.

COMPLIANCE REQUIRED

Within the next 10 hours TIS or two calendar months after the effective date of this AD, whichever occurs first and thereafter at intervals not to exceed 600 hours TIS or 60 calendar months since last inspection, whichever occurs first.

Prior to further flight, and thereafter at intervals not to exceed 600 hours TIS or 60 calendar months since last inspection, whichever occurs first.

(a) Remove affected propeller hub assemblies from the aircraft and return to Hartzell Propeller Inc., One Propeller Place, Piqua, OH 45356-2634 U.S.A. for inspection and specified rework procedures, in accordance with Hartzell Alert Service Bulletin (ASB) No. A182, dated April 28, 1993. Propeller hubs removed from Mitsubishi Model MU-2B-60 aircraft may not be installed on any other aircraft unless an inspection is performed in accordance with Hartzell ASB No. A182, dated April 28, 1993.

(b) Reinstall affected propeller hub assemblies that have had the hub arm bores inspected and reworked as necessary, pilot tubes replaced, and marked at the end of the hub serial number with suffix letter "M", followed by a number (1,2,3, etc.) to indicate the number of repetitive inspections performed in accordance with Hartzell ASB No. A182, dated April 28, 1993; or install new production hubs which have passed the inspection and have been marked at the end of the hub serial number with the suffix letter "M".

(c) A blade strike is defined as a propeller having any blade(s) that has been bent beyond repair limits in accordance with Hartzell Service Letter 61R, dated February 28, 1992.

(d) The calendar month compliance time stated in this AD allow the performance of the required action prior to the last day of the month in which compliance is required.

NOTE: For example, if action is required 2 calendar months from April 28, 1993, the required actions are to be performed not later than June 30, 1993.

(e) An alternate method of compliance or adjustment of the compliance time that provides an acceptable level of safety may be used if approved by the Manager, Chicago Aircraft Certification Office. The request should be forwarded through an appropriate FAA Maintenance Inspector, who may add comments and then sent it to the Manager, Chicago Aircraft Certification Office.

NOTE 1: Information concerning the existence of approved alternative methods of compliance with this Airworthiness Directive, if any, may be obtained from Chicago Aircraft Certification Office.

NOTE 2: Although Hartzell Propeller is presently the only FAA-approved repair facility authorized to conduct the requirements of this AD, other facilities may be authorized through the alternative method of compliance procedure in paragraph (e) of this AD.

(f) Except when propeller hub assemblies experience a blade strike after the effective date of this AD, special flight permits may be issued in accordance with FAR 21.197 and 21.199 to operate the airplane to a location where the requirements of this AD can be accomplished.

(g) The removal from service, inspection, rework, and reinstallation shall be done in accordance with the following alert service bulletin:

Document No.	Revision	Date
Hartzell ASB No. A182	1-3	Original
		April 28, 1993

Total pages: 3

This incorporation by reference was approved by the Director of the Federal Register in accordance with 5 U.S.C. 552(a) and 1 CFR part 51. Copies may be obtained from Hartzell Propeller, Inc., One Propeller Place, Piqua, OH 45356-2634. Copies may be inspected at the FAA, New England Region, Office of the Assistant Chief Counsel, 12 New England Executive Park, Burlington, MA; or at the Office of the Federal Register, 800 North Capitol Street, NW., suite 700, Washington DC.

(h) This amendment becomes effective August 6, 1993, to all persons except those persons to whom it was made immediately effective by priority letter AD 93-09-04, issued April 28, 1993, which contained the requirements of this amendment.

FOR FURTHER INFORMATION CONTACT:

Tim Smyth, Aerospace Engineer, Chicago Aircraft Certification Office, FAA, Small Airplane Directorate, 2300 East Devon Avenue, Room 232, Des Plaines, IL 60018; telephone (312) 694-7130, fax (312) 694-7834.