

Includes  
Teacher's notes  
and  
Typical  
Experiment Results

# **Instruction Manual and Experiment Guide for the PASCO scientific Model OS-8515**

012-05628C  
7/95

## **BASIC OPTICS**

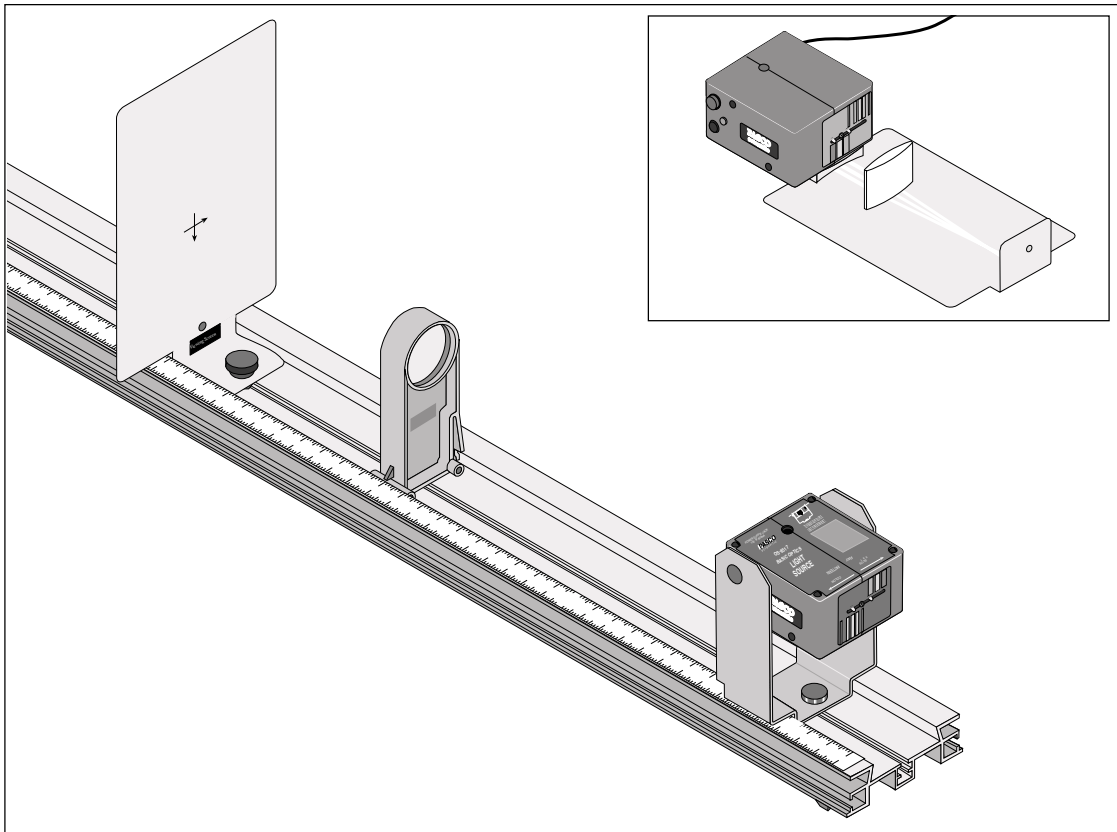

© 1995 PASCO scientific

# Table of Contents

<b>Section</b>	<b>Page</b>
Copyright, Warranty, and Equipment Return .....	ii
Introduction .....	1
Equipment .....	2
Setting Up the Equipment .....	3-4
<b>Basic Experiments</b>	
<b>Ray Box Experiments</b>	
Experiment 1: Color Addition .....	5
Experiment 2: Prisms .....	7
Experiment 3: Reflection; Plane and Curved Mirrors .....	9
Experiment 4: Snell's Law .....	11
Experiment 5: Total Internal Reflection .....	13
Experiment 6: Refraction; Convex and Concave Lenses .....	15
Experiment 7: Lensmaker's Equation .....	17
Experiment 8: Apparent Depth .....	19
<b>Optics Bench Experiments</b>	
Experiment 9: Focal Length of a Thin Lens .....	21
Experiment 10: Telescope .....	23
Experiment 11: Microscope .....	27
Experiment 12: Shadows .....	29
<b>Photometer Experiments</b>	
Experiment 13: Inverse Square Law .....	31
Experiment 14: Polarization .....	33
Teachers Guide .....	37
Technical Support .....	Back Cover

# Introduction

The PASCO OS-8517A Light Source includes:

- light box
- 12-Volt adapter
- bracket for mounting the light box to the optics bench

The source of light inside the light box is a 10-Watt 12-Volt halogen bulb (Philips Order Code: 13284; Philips Description: 10W/12V/Capsule, PASCO part number 526-035). This light source is designed to be used in two ways:

- ① The Light Source can be used without the bracket attached as a ray box which sits directly on the table. The OS-8516 Ray Optics Kit supplies free-standing lenses, mirrors, and a rhombus to use with the ray box. The ray box can produce one to five white light rays. When the ray box is inverted it produces three primary color rays.

- ② The Light Source can be mounted to the Optical Bench which is part of the OS-8518 Geometric Optics Kit .

The OS-8518 Kit includes:

- optics bench
- viewing screen
- two 50 mm diameter lenses
  - focal length +100 mm, in holder
  - focal length +200 mm, in holder

While mounted in the bracket, the Light Source can be used either as a target-shaped lighted object or it can be rotated into a new position to become a point light source.

The Basic Optics System (OS-8515) includes:

- OS-8517A Light Source
- OS-8516A Ray Optics Kit
- OS-8518 Geometric Optics Kit

Additional accessories available include:

- OS-8519 a set of two additional mounted lenses
  - focal length +250 mm
  - focal length -150 mm
- OS-8520 a non-electric comparative Photometer which includes:
  - set of mounted polarizers
  - neutral density filter set that allow 25%, 50%, 75%, and 100% transmittance.

## Photometer

The PASCO Photometer (OS-8520) operates in a similar fashion to a wax photometer except the wax is replaced by two high brightness fluorescent acrylic disks. By looking through the eyepiece, students can see if the disks, each receiving light from an opposite side of the photometer, are equal in intensity. Although it is difficult for the eye to determine relative intensities, it can detect equal intensities quite accurately.

A set of neutral density transmission filters (25, 50, 75, and 100%) are included to be used on the Photometer to block out a known amount of light so quantitative measurements may be made. Note that because the Photometer uses a fluorescent material, it will not respond equally in the red and violet parts of the spectrum. This Photometer was designed to be used with white light, such as the PASCO Light Source (OS-8517A). To decrease the intensity of the light that is emitted by the light source, use a mask rather than decreasing the voltage to the bulb. The use of a mask preserves the white color of the light whereas a decrease in the voltage would change the color of the emitted light to red.

A set of two mounted polarizers is also included. The polarizer perimeters are marked in degrees and the polarizers can be rotated to any angle to show the amount of extinction of the transmitted light.

All the filters snap into the ends of the photometer and can be rotated once they are snapped into place. The polarizers are designed to fit on their own separate holder. One polarizer can be snapped into each side of this holder.

## How to Use the Photometer

To determine if the two sides of the photometer are illuminated by light of equal intensity, look down into the conical eyepiece of the photometer. The cone is designed to cast a shadow on the inner parts of the photometer to allow a better view. Do not put your eye directly on the eyepiece: Keep your head back at a distance which allows you to comfortably focus on the orange indicator. If the light is the same brightness on each side, the color and brightness of the two sides of the orange indicator will appear to be the same.

# Equipment

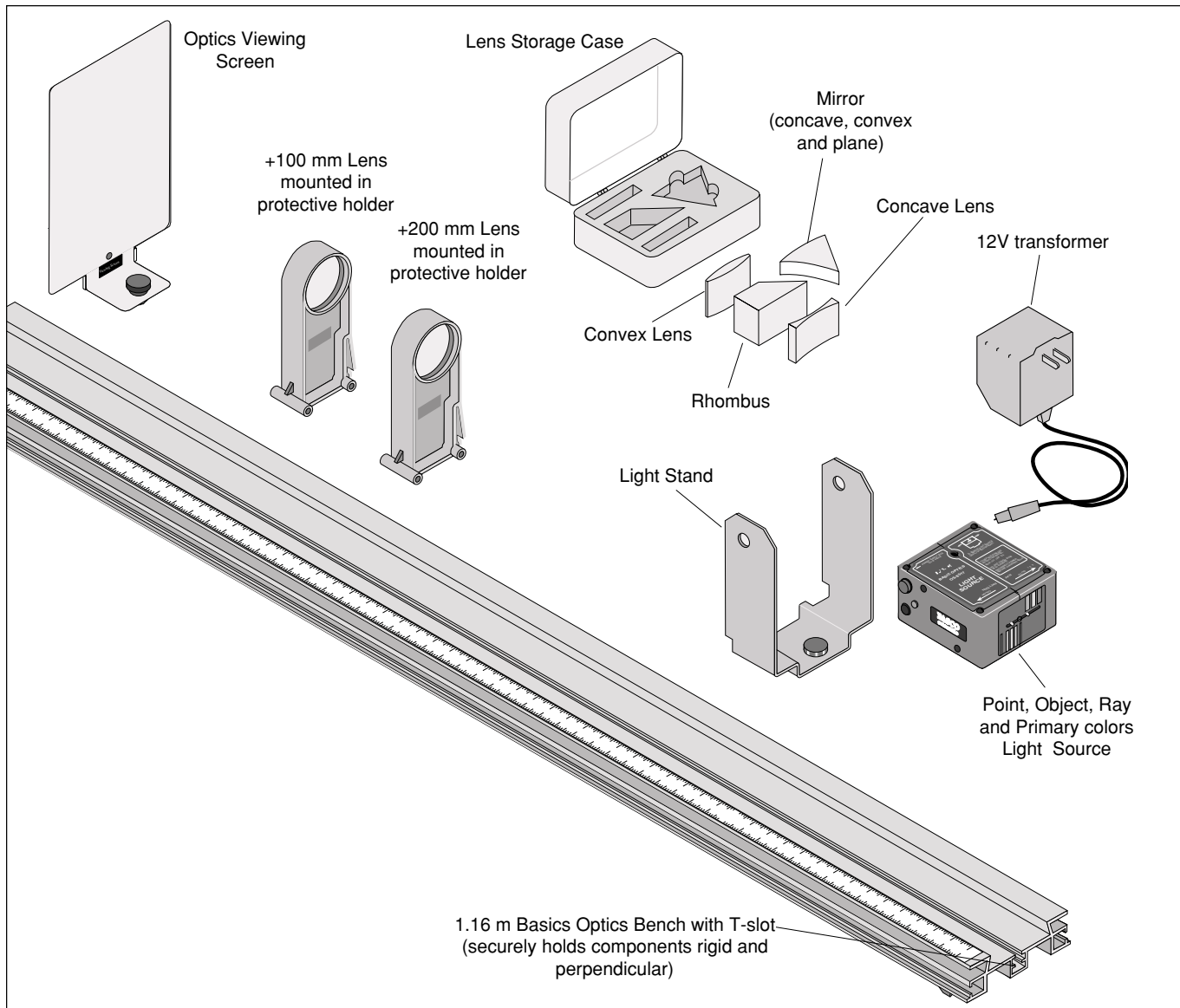

**Equipment included in the, OS-8515 Basic Optics System.**

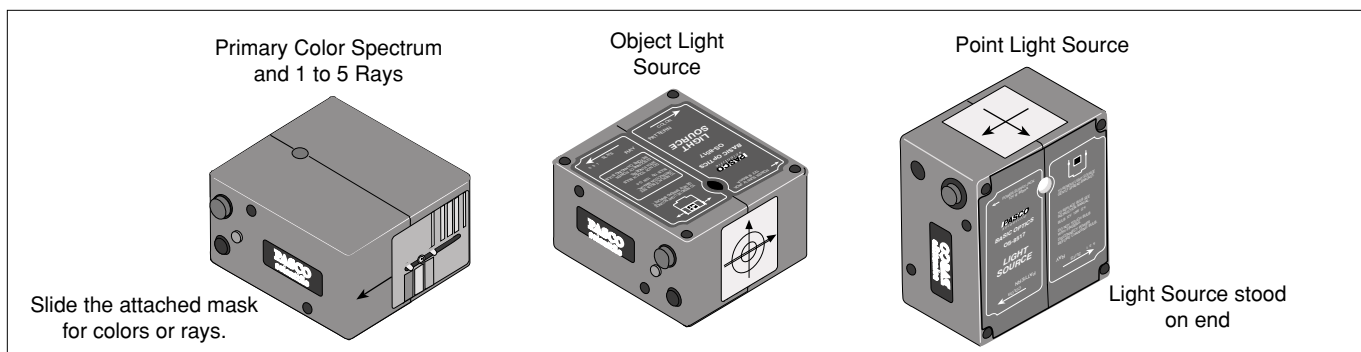

**Multi use Light Source**

## Setup:

### Mounting the Light Source to the Optics Bench

The bracket must be attached to the Light Source to mount it on the optics bench. See Figure 1. The power cord from the transformer must be unplugged from the Light Source before taking the bracket off or putting the bracket on. The Light Source is held in place by the spring action of the bracket. To attach the bracket, hold the light source box in one hand and pull outward on each of the bracket's two sides and insert the light box's side tabs into the holes in the sides of the bracket. Note that the crossed-arrow target should face the front side of the bracket which can be identified by the cut-away areas in the lower side portions of the bracket. See Figure 1 or see the label on the side of the bracket for the correct positioning of the light source.

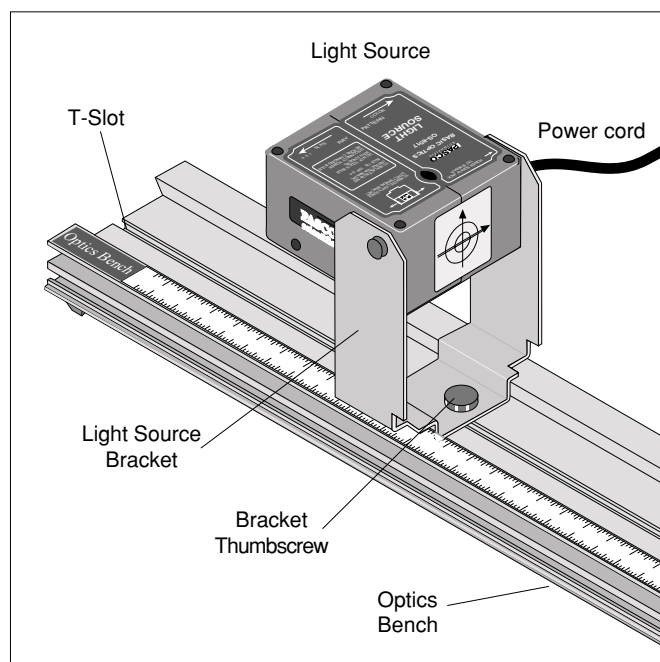

**Figure 1: Light Source**

Attach the bracket to the optics bench by inserting the nut into the T-slot in the center of the track. The bracket can be slid to any position on the track while the thumbscrew is loose. Tighten the thumbscrew to secure the light source at any position. Rotate the Light Source box in its bracket until its label side is up and the box clicks into place. In this horizontal position, the Light Source acts as a cross-arrow target object. To use the Light Source as a point light source, rotate the Light Source box into its vertical position. It will click into position. Regardless of which orientation the Light Source box is locked into, the plane of the object is indicated on the metric tape on the bench by the recessed portion of the base of the bracket. Plug the cord from the transformer into the power supply jack.

### Using the Light Source as a Ray Box

To use the Light Source as a ray box, remove the bracket if it is attached. The power cord from the transformer must be unplugged from the Light Source before taking the bracket off or putting the bracket on. See Figure 1. The Light Source is held in place by the spring action of the bracket. To remove the bracket, hold the light source box in one hand and pull outward on each of the bracket's two sides, pulling the light box's side tabs out of the bracket.

Set the Light Source box on a piece of white paper on the table. Plug the transformer into the power supply jack on the side of the light box. If you set the Light Source on the table with the label side up, it will produce white light rays. If the label side is down, it will produce the three primary colors. To select the number (1, 3, 5) of white rays, slide the plastic mask which is fastened to the front of the box until you see the desired number of rays.

## Mounting the Screen and Lenses to the Optics Bench (OS-8518)

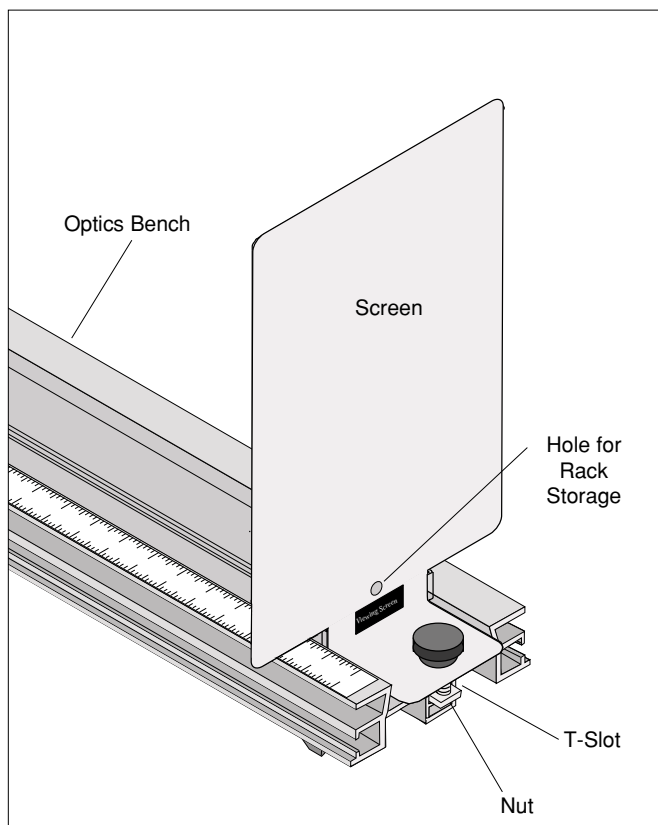

Figure 2: Mounting Screen on Bench

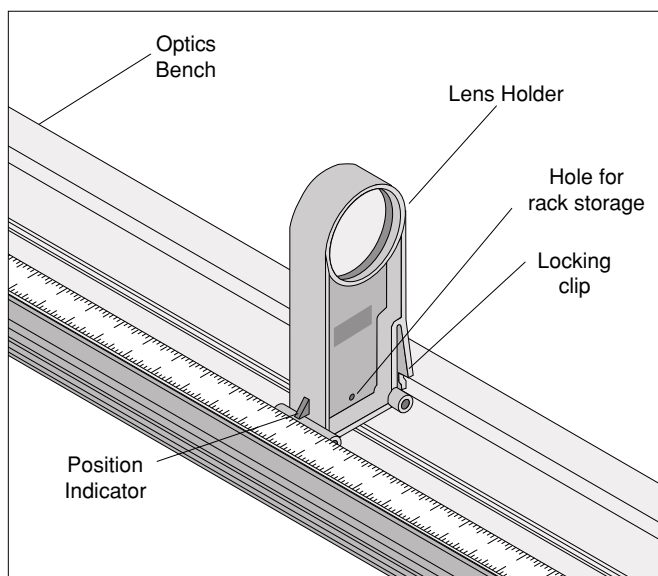

Figure 3: Mounting Lens holder on Bench

To mount the viewing screen to the Optics Bench, slide the square nut into the center T-slot in the bench. See Figure 2 below, Mounting Screen on Bench.

The lenses simply snap into place on the bench. See Figure 3, Mounting Lens holders on Bench. There is no need to slide them on from the end of the bench. To slide the lens holder along the bench, grasp the lens holder at its base and squeeze the locking clip on the side of the holder. Continue to squeeze the locking clip while the lens is slid along or removed from the bench. When the locking clip is released the lens is held firmly in place.

### Storage

All parts (lens holders, screen, etc.) have a hole allowing them to be hung on a peg board for compact storage. The light source can be hung by its bracket or stacked on a shelf.

The experiments can be arranged in categories according to which equipment is used with the Light Source:

### Ray Box Experiments

- ① Color Addition
- ② Prisms
- ③ Reflection: Plane and Curved Mirrors
- ④ Snell's Law
- ⑤ Total Internal Reflection
- ⑥ Refraction: Convex and Concave Lenses
- ⑦ Lensmaker's Equation
- ⑧ Apparent Depth

### Optics Bench Experiments

- ⑨ Focal Length of a Thin Lens
- ⑩ Telescope
- ⑪ Microscope

Shadows

### Photometer Experiments

Inverse Square Law  
Polarization



- Shine the three primary colors on each of the colored sheets of paper. What color does each sheet of paper appear to be for each color of illuminating light? Record the results in Table 1.2.

**Table 1.2 Results of Reflection Off Colored Paper**

COLOR OF PAPER IN WHITE LIGHT	COLOR OF LIGHT RAY	COLOR OF PAPER IN COLORED LIGHT
	Red	
	Green	
	Blue	
	Red	
	Green	
	Blue	
	Red	
	Green	
	Blue	
	Red	
	Green	
	Blue	



## Experiment 2: Prism

### EQUIPMENT NEEDED

- Ray box (white ray)
- Rhombus

### Purpose

To show how a prism separates white light into its component colors and to show that different colors are refracted at different angles through a prism.

### Theory

According to Snell's Law,

$$n_1 \sin \theta_1 = n_2 \sin \theta_2$$

the angle of refraction depends on the angle of incidence and the index of refraction of the material. See Figure 2.1. Because the index of refraction for light varies with the frequency of the light, white light which enters the material at a given angle of incidence will separate out into its component colors as each frequency is bent a different amount.

The rhombus is made of Acrylic which has an index of refraction of 1.497 for light of wavelength 486 nm in a vacuum, 1.491 for wavelength 589 nm, and 1.489 for wavelength 651 nm (red). Notice that in general for visible light, the index of refraction for Acrylic increases with increasing frequency.

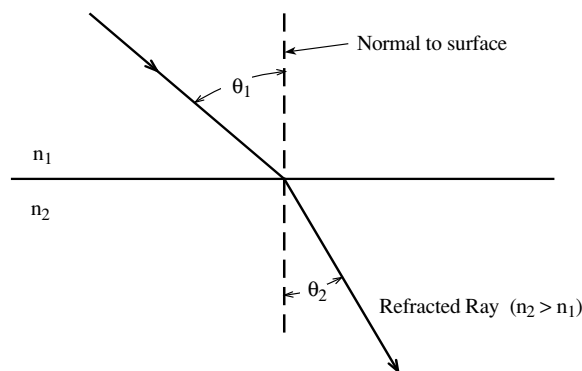

Figure 2.1: Refraction of Light

## Procedure for Separating White Light

① Place the ray box, label side up, on a white sheet of paper on the table. Adjust the box so one white ray is showing. If the white screen from the OS-8518 Optics Bench is available, it can be laid flat on the table to make a good viewing platform for this experiment.

② Position the rhombus as shown in Figure 2.2. The triangular end of the rhombus is used as a prism in this experiment. Keep the ray near the point of the rhombus for maximum transmission of the light.

③ Rotate the rhombus until the angle ( $\theta$ ) of the emerging ray is as large as possible and the ray separates into colors.

(a) What colors are seen and in what order are they?

(b) Which color is refracted at the largest angle?

(c) According to Snell's Law and the information given about the frequency dependence of the index of refraction for Acrylic, which color is predicted to refract at the largest angle?

④ Turn the ray box over and shine the three primary color rays into the rhombus at the same angle used for the white ray. Do the colored rays emerge from the rhombus parallel to each other? Why or why not?

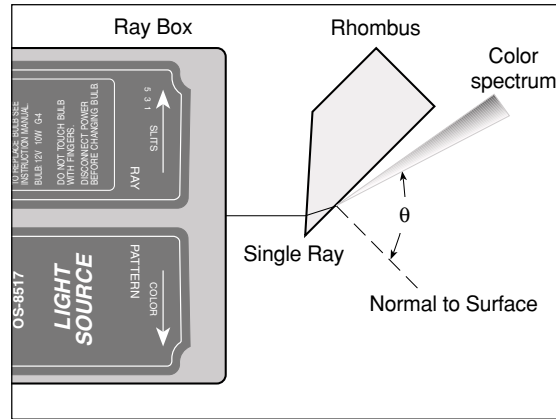

**Figure 2.2**

## Experiment 3: Reflection – Plane and Curved Mirrors

### EQUIPMENT NEEDED

- Ray box (single and multiple white rays)
- Plane and curved mirrors
- Protractor (SE-8732)
- Drawing compass (SE-8733)
- Metric rule
- White paper

### Purpose

To study how rays are reflected and to determine the focal length and radius of curvature of different types of mirrors.

### Part I: Plane Mirror

#### Procedure

- ① Place the ray box, label side up, on a white sheet of paper on the table. Adjust the box so one white ray is showing.
- ② Place the mirror on the table and position the plane surface of the mirror at an angle to the ray so that the both the incident and reflected rays are clearly seen.
- ③ Mark the position of the surface of the plane mirror and trace the incident and reflected rays. Indicate the incoming and the outgoing rays with arrows in the appropriate directions.
- ④ On the paper, draw the normal to the surface. See Figure 3.1.
- ⑤ Measure the angle of incidence ( $\theta_i$ ) and the angle of reflection. Both these angles should be measured from the normal. Record the angles in Table 3.1.
- ⑥ Change the angle of incidence and measure the incident and reflected angles again. Repeat this procedure for a total of three different incident angles.

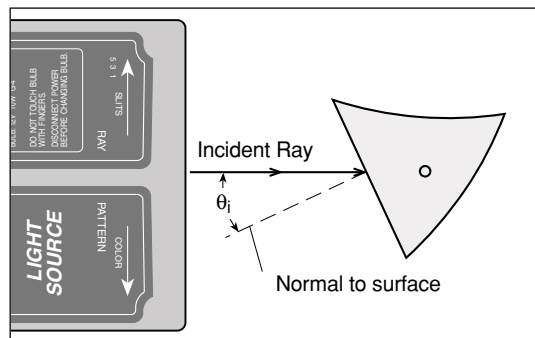

**Figure 3.1**

- ⑦ Adjust the ray box so it produces the three primary color rays. Shine the colored rays at an angle to the plane mirror. Mark the position of the surface of the plane mirror and trace the incident and reflected rays. Indicate the colors of the incoming and the outgoing rays and mark them with arrows in the appropriate directions.

**Table 3.1 Plane Mirror Results**

Angle of Incidence	Angle of Reflection

**Questions**

- ① What is the relationship between the angle of incidence and the angle of reflection?
- ② Are the three colored rays reversed left-to-right by the plane mirror?

**Part II: Cylindrical Mirrors**

**Theory**

A concave cylindrical mirror will focus parallel rays of light at the focal point. The focal length is the distance from the focal point to the center of the mirror surface. The radius of curvature of the mirror is twice the focal length. See Figure 3.2.

**Procedure**

- ① Using five white rays from the ray box, shine the rays straight into the concave mirror so the light is reflected back toward the ray box. See Figure 3.3. Draw the surface of the mirror and trace the incident and reflected rays. Indicate the incoming and the outgoing rays with arrows in the appropriate directions.
- ② The place where the five reflected rays cross each other is the focal point of the mirror. Measure the focal length from the center of the concave mirror surface to the focal point. Record the result in Table 3.2.
- ③ Use the compass to draw a circle that matches the curvature of the mirror. Measure the radius of curvature using a rule and record it in Table 3.2.
- ④ Repeat Steps 1 through 3 for the convex mirror. Note that in Step 2, the reflected rays are diverging for a convex mirror and they will not cross. Use a rule to extend the reflected rays back behind the mirror's surface. The focal point is where these extended rays cross.

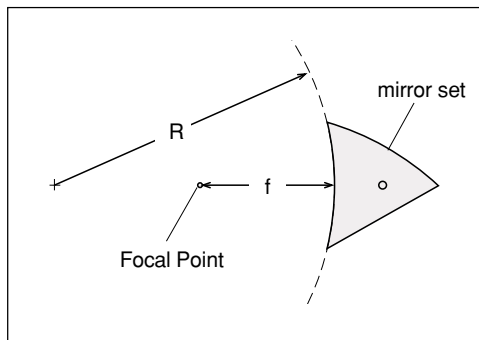

Figure 3.2

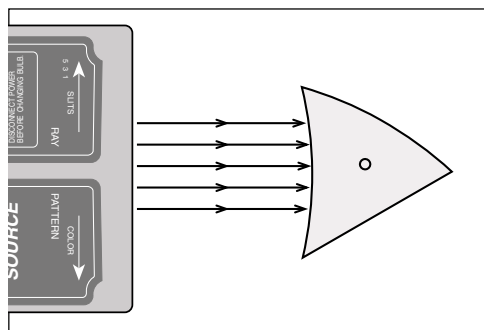

Figure 3.3

**Table 3.2 Cylindrical Mirror Results**

	Concave Mirror	Convex Mirror
Focal Length		
Radius of Curvature using compass		

**Questions**

- ① What is the relationship between the focal length of a cylindrical mirror and its radius of curvature? Do your results confirm your answer?
- ② What is the radius of curvature of a plane mirror?

## Experiment 4: Snell's Law

### EQUIPMENT NEEDED

- Ray box (single white ray and colored rays)
- Rhombus
- Protractor (SE-8732)
- White paper

### Purpose

To use Snell's Law to determine the index of refraction of the acrylic rhombus.

### Theory

Snell's Law states

where  $\theta_1$  is the angle of incidence,  $\theta_2$  is the angle of refraction, and  $n_1$  and  $n_2$  are the respective indices of refraction of the materials. See Figure 4.1.

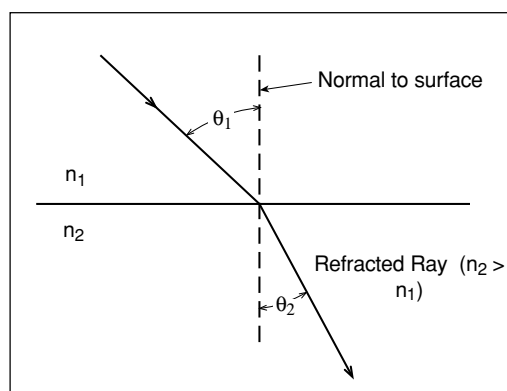

Figure 4.1

$$n_1 \sin \theta_1 = n_2 \sin \theta_2$$

### Procedure

- ① Place the ray box, label side up, on a white sheet of paper on the table. Slide the ray mask until only one white ray is showing.
- ② Place the rhombus on the table and position it so the ray passes through the parallel sides as shown in Figure 4.2.
- ③ Mark the position of the parallel surfaces of the rhombus and trace the incident and transmitted rays. Indicate the incoming and the outgoing rays with arrows in the appropriate directions. Mark carefully where the ray enters and leaves the rhombus.
- ④ Remove the rhombus and on the paper draw a line connecting the points where the ray entered and left the rhombus.
- ⑤ Choose either the point where the ray enters the rhombus or the point where the ray leaves the rhombus. At this point, draw the normal to the surface.
- ⑥ Measure the angle of incidence ( $\theta_i$ ) and the angle of refraction with a protractor. Both these angles should be measured from the normal. Record the angles in Table 4.1.
- ⑦ Change the angle of incidence and measure the incident and refracted angles again. Repeat this procedure for a total of three different incident angles.

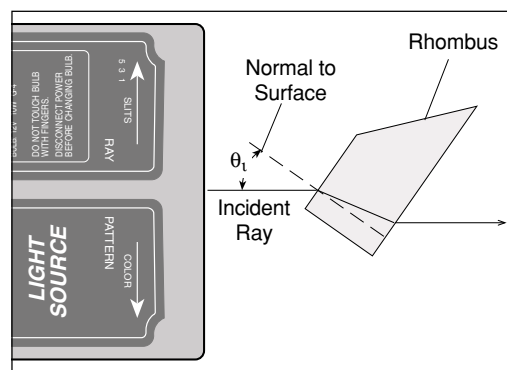

Figure 4.2

**Table 4.1 Data and Results**

Angle of Incidence	Angle of Refraction	n rhombus
Average index of refraction		

**Analysis**

- ① Using Snell’s Law and your data, calculate the index of refraction for the Acrylic rhombus, assuming the index of refraction of air is one. Record the result for each of the three data sets in Table 4.1.
- ② Average the three values of the index of refraction and compare to the accepted value ( $n = 1.5$ ) using a percent difference.

**Question**

What is the angle of the ray that leaves the rhombus relative to the ray that enters the rhombus?

## Experiment 5: Total Internal Reflection

### EQUIPMENT NEEDED

- Ray box (single ray)
- Rhombus
- Protractor (SE-8732)
- White paper

### Purpose

To determine the critical angle at which total internal reflection occurs and to confirm it using Snell's Law.

### Theory

Snell's Law states

$$n_1 \sin \theta_1 = n_2 \sin \theta_2$$

where  $\theta_1$  is the angle of incidence,  $\theta_2$  is the angle of refraction, and  $n_1$  and  $n_2$  are the respective indices of refraction of the materials. See Figure 5.1.

If a ray of light traveling from a medium of greater index of refraction to a medium of lesser index of refraction is incident with an angle greater than the critical angle ( $\theta_c$ ), there is no refracted ray and total internal reflection occurs. If the angle of incidence is exactly the critical angle, the angle of the refracted ray is 90 degrees. See Figure 5.2. In this case, using Snell's Law,

assuming the medium of lesser index of refraction is air with  $n_2 = 1$  and the medium of greater index of refraction is the Acrylic rhombus with  $n_1 = n = 1.5$ . Solving for the critical angle gives

### Procedure

- ① Place the ray box, label side up, on a white sheet of paper on the table. Slide the ray mask until only one white ray is showing.
- ② Position the rhombus as shown in Figure 5.3. Do not shine the ray through the rhombus too near the triangular tip.

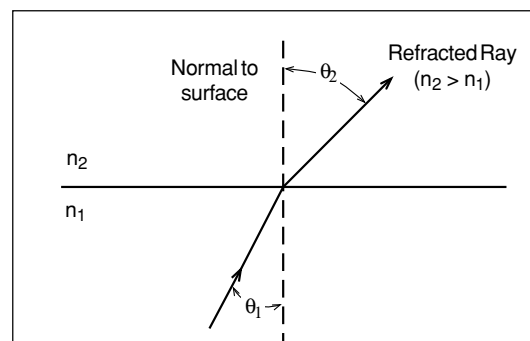

Figure 5.1

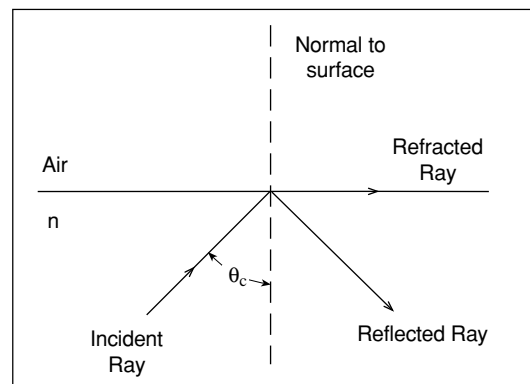

Figure 5.2

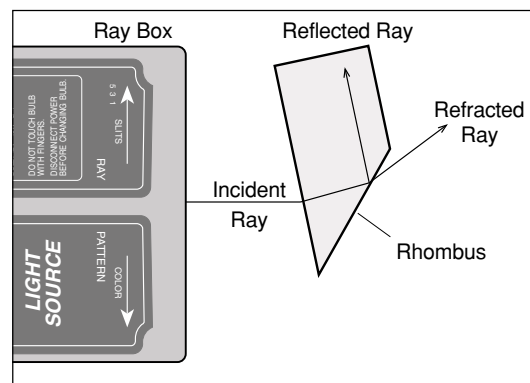

Figure 5.3

- ③ Rotate the rhombus until the emerging ray just barely disappears. Just as it disappears, the ray separates into colors. The rhombus is correctly positioned if the red has just disappeared.
- ④ Mark the surfaces of the rhombus. Mark exactly the point on the surface where the ray is internally reflected. Also mark the entrance point of the incident ray and mark the exit point of the reflected ray.
- ⑤ Remove the rhombus and draw the rays that are incident upon and that reflect off the inside surface of the rhombus. See Figure 5.4. Measure the total angle between these rays using a protractor. If necessary, you may extend these rays to make the protractor easier to use. Note that this total angle is twice the critical angle because the angle of incidence equals the angle of reflection. Record the critical angle here: \_\_\_\_\_
- ⑥ Calculate the critical angle using Snell's Law and the given index of refraction for Acrylic. Record the theoretical value here: \_\_\_\_\_
- ⑦ Calculate the percent difference between the measured and theoretical values:  
% difference = \_\_\_\_\_

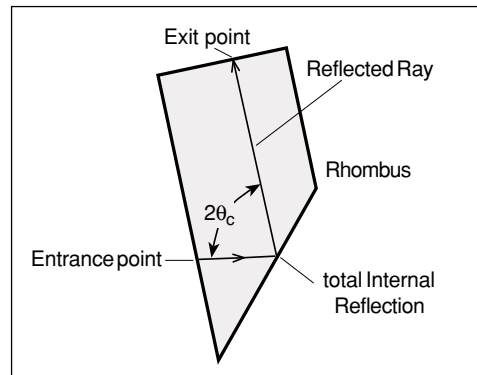

Figure 5.4

### Questions

- ① How does the brightness of the internally reflected ray change when the incident angle changes from less than  $\theta_c$  to greater than  $\theta_c$ ?
- ② Is the critical angle greater for red light or violet light? What does this tell you about the index of refraction?



## Experiment 6: Refraction – Convex and Concave Lenses

### EQUIPMENT NEEDED

- Ray box (multiple white rays)
- Convex lens
- Concave lens
- Metric rule
- Second convex lens (optional)

### Purpose

To explore the difference between convex and concave lenses and to determine their focal lengths.

### Theory

Parallel rays of light passing through a thin convex lens cross at the focal point of the lens. The focal length is measured from the center of the lens to the focal point.

### Procedure

- ① Place the ray box on a white piece of paper. Using five white rays from the ray box, shine the rays straight into the convex lens. See Figure 6.1.

**NOTE:** Concave and Convex lenses have only one flat edge. Place flat edge on surface.

Trace around the surface of the lens and trace the incident and transmitted rays. Indicate the incoming and the outgoing rays with arrows in the appropriate directions.

- ② The place where the five refracted rays cross each other is the focal point of the lens. Measure the focal length from the center of the convex lens to the focal point. Record the result in Table 6.1.

**Table 6.1 Results**

	Convex Lens	Concave Lens
Focal Length		

- ③ Repeat the procedure for the concave lens. Note that in Step 2, the rays leaving the lens are diverging and they will not cross. Use a rule to extend the outgoing rays straight back through the lens. The focal point is where these extended rays cross.
- ④ Nest the convex and concave lenses together and place them in the path of the parallel rays. Trace the rays. What does this tell you about the relationship between the focal lengths of these two lenses?

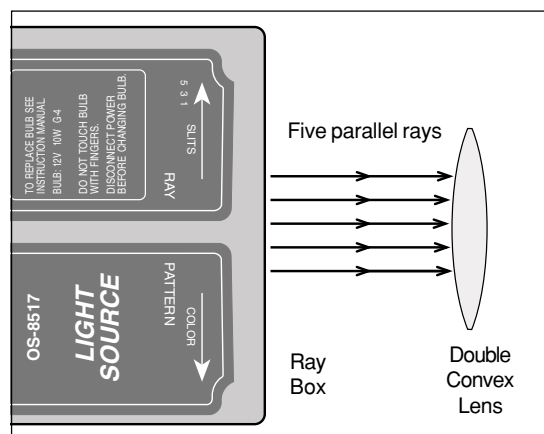

**Figure 6.1**

- 
- ⑤ Slide the convex and concave lenses apart to observe the effect of a combination of two lenses. Then reverse the order of the lenses. Trace at least one pattern of this type.
  - ⑥ Place the convex lens in the path of the five rays. Block out the center 3 rays (the mirror on edge works well) and mark the focal point for the outer two rays. Next, block out the outer two rays (or slide the mask to the position that gives 3 rays) and mark the focal point for the inner 3 rays. Are the two focal points the same?
  - ⑦ If you have a second convex lens, place both convex lenses in the path of the five rays. The distance between the lenses should be less than the focal length of the lenses. Compare the quality of the focus of this two lens system to the focus of a single lens. Do all five rays cross in the same place?

## Experiment 7: Lensmaker's Equation

### EQUIPMENT NEEDED

- Ray box (multiple white rays)
- Concave lens
- Metric rule

### Purpose

To determine the focal length of a convex lens by direct measurement and by using the lensmaker's equation.

### Theory

The lensmaker's equation is used to calculate the focal length of a lens based on the radii of curvature of its surfaces and the index of refraction of the lens material.

$$\frac{1}{f} = (n - 1) \left( \frac{1}{R_1} + \frac{1}{R_2} \right)$$

where  $f$  is the focal length,  $n$  is the relative index of refraction of the lens material, and  $R_1$  and  $R_2$  are the radii of curvature of the lens surfaces.

**NOTE:** In this notation,  $R$  is positive for a convex surface (as viewed from outside the lens) and  $R$  is negative for a concave surface. See Figure 7.1.

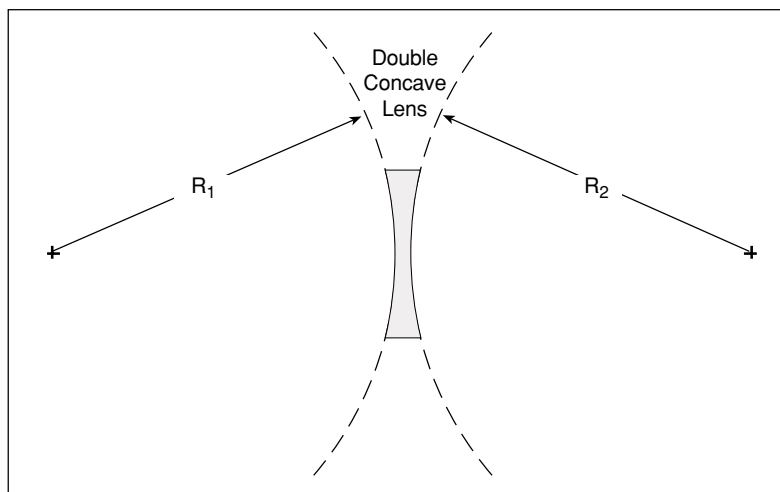

Figure 7.1

### Procedure

- ① Place the ray box on a white piece of paper. Using five white rays from the ray box, shine the rays straight into the concave lens. See Figure 7.2. Trace around the surface of the lens and trace the incident and transmitted rays. Indicate the incoming and the outgoing rays with arrows in the appropriate directions.
- ② Remove the lens. To measure the focal length, use a rule to extend the outgoing diverging rays straight back through the lens. The focal point is where these extended rays cross. Measure the distance from the center of the lens to the focal point. Record the result:  $f =$  \_\_\_\_\_

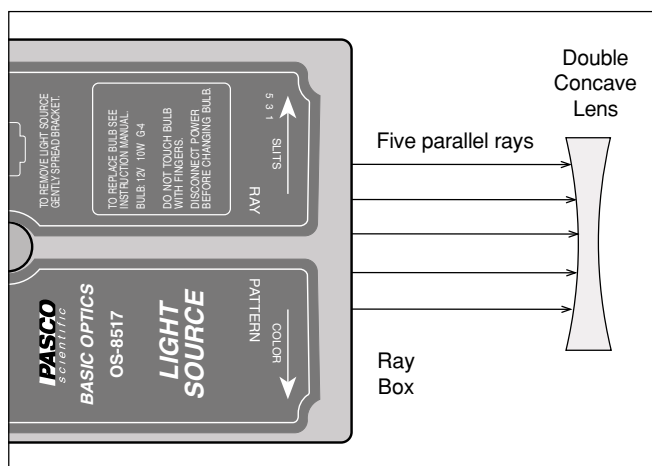

Figure 7.2

- ③ To determine the radius of curvature, put the concave lens back in the path of the rays and observe the faint reflected rays off the first surface of the lens. The front of the lens can be treated as a concave mirror having a radius of curvature equal to twice the focal length of the effective mirror. Trace the surface of the lens and the incident rays and the faint reflected rays. Measure the distance from the center of the front curved surface to the point where the faint reflected rays cross. See Figure 7.3. The radius of curvature of the surface is twice this distance. Record the radius of curvature:

R = \_\_\_\_\_.

- ④ Note that the lens is symmetrical and it is not necessary to measure the curvature of both sides of the lens because R is the same for both. Calculate the focal length of the lens using the lensmaker's equation. The index of refraction is 1.5 for the Acrylic lens. Remember that a concave surface has a negative radius of curvature.  $f =$  \_\_\_\_\_
- ⑤ Calculate the percent difference between the two values of the focal length of the concave lens.  
% difference = \_\_\_\_\_

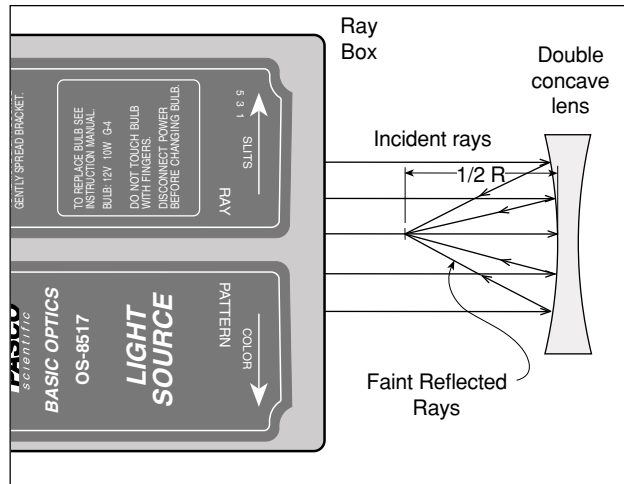

Figure 7.3

## Questions

- ① Is the focal length of a concave lens positive or negative?
- ② How might the thickness of the lens affect the results of this experiment?

## Experiment 8: Apparent Depth

### EQUIPMENT NEEDED

- |                                      |               |
|--------------------------------------|---------------|
| – Ray box                            | – Convex lens |
| – Rhombus                            | – Metric rule |
| – Mirror (Used to block center rays) |               |

### PART I

### Purpose

To determine the index of refraction using apparent depth.

### Theory

Light rays originating from the bottom surface of a block of material refract at the top surface as the rays emerge from the material into the air. See Figure 8.1. When viewed from above, the apparent depth,  $d$ , of the bottom surface of the block is less than the actual thickness,  $t$ , of the block. The apparent depth is given by  $d = t/n$ , where  $n$  is the index of refraction of the material.

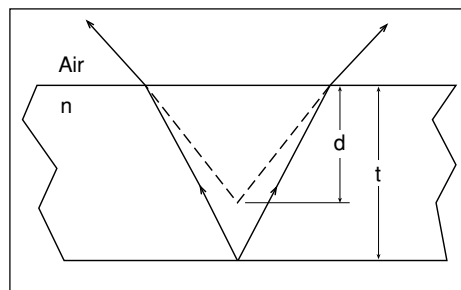

Figure 8.1

### Procedure

- ① Place the ray box on a white piece of paper. Using five white rays from the ray box, shine the rays straight into the convex lens. See Figure 8.2. Place the mirror on its edge between the ray box and the lens so that it blocks the middle three rays, leaving only the outside two rays.
- ② Mark the place where the two rays cross each other.
- ③ Place the rhombus as shown in Figure 8.2. The bottom surface of the rhombus must be exactly at the point where the two rays cross. The crossed rays simulate the rays that emerge from the bottom of the rhombus block discussed in the theory.
- ④ Trace the bottom and top surfaces of the rhombus and trace the rays diverging from the top surface.
- ⑤ Remove the rhombus, turn off the light source, and trace the diverging rays back into the rhombus. The place where these rays cross (inside the rhombus) is the apparent position of the bottom of the rhombus when viewed from the top.
- ⑥ Measure the apparent depth,  $d$ , and the thickness,  $t$ .

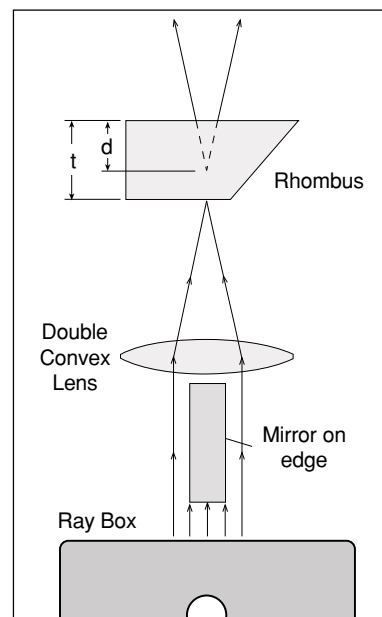

Figure 8.2

$d =$  \_\_\_\_\_

$t =$  \_\_\_\_\_

- ⑦ Calculate the index of refraction of the material using  $n = t/d$ .  $n =$  \_\_\_\_\_

- ⑧ Calculate the percent difference between the measured value of the accepted value ( $n = 1.5$ ).

% difference = \_\_\_\_\_

## PART II

### Theory

Parallel rays passing through a convex lens cross at the focal point of the lens. If a block with parallel sides is placed between the lens and the focal point, the point where the rays cross moves further from the lens. Since the thickness,  $t$ , of the block has an apparent depth,  $d$ , that is less than the thickness ( $d = t/n$ ), the point where the rays cross must move by an amount equal the difference between the actual thickness of the block and the apparent thickness of the block. Thus the distance,  $x$ , that the focal point moves is given by  $x = t - t/n$ , where  $n$  is the index of refraction of the block.

### Procedure

- ① Turn the light source on. Using a new sheet of paper, mark the place where the two rays cross.
- ② Set the rhombus between the lens and the place where the rays cross. See Figure 8.3. Mark the new place where the rays cross.
- ③ Move the rhombus to a new position, closer to the lens. Does the position of the focal point change?

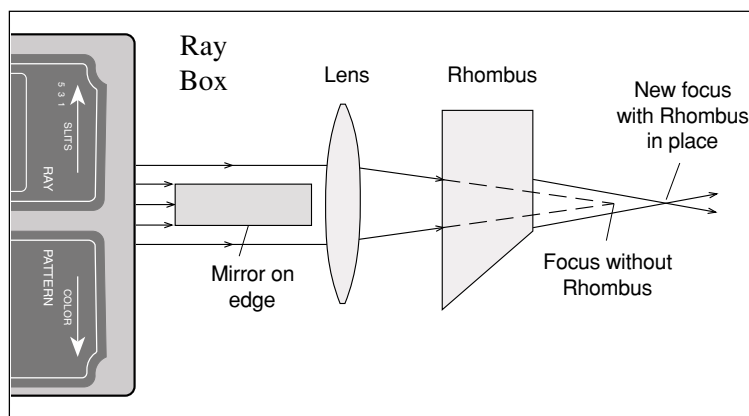

**Figure 8.3**

- ④ Turn off the light source and measure the distance,  $x$ , between the marks.  $x =$  \_\_\_\_\_
- ⑤ Using the thickness of the rhombus from Part I and the distance  $x$ , calculate the index of refraction using  $n =$  \_\_\_\_\_
- ⑥ Calculate the percent difference between the measured value of the accepted value ( $n = 1.5$ ).  
% difference = \_\_\_\_\_

## Experiment 9: Focal Length of a Thin Lens

### EQUIPMENT NEEDED

- Bench (OS-8518)
- Convex lens
- Light source (object) (OS-8517)
- Screen

### Purpose

To determine the focal length of a thin lens.

### Theory

For a thin lens:  $\frac{1}{f} = \frac{1}{d_o} + \frac{1}{d_i}$

where  $f$  is focal length,  $d_o$  is the distance between the object and the lens, and  $d_i$  is the distance between the image and the lens. See Figure 9.1.

### Procedure

#### I. FOCAL LENGTH USING AN OBJECT AT INFINITY

- ① Using one of the positive lenses focus a distant light source on a paper.
- ② Measure the distance from the lens to the paper. This is the image distance.
- ③ Take the limit as the object distance goes to infinity in the Thin Lens Formula:

$$\frac{1}{f} = \frac{1}{d_o} + \frac{1}{d_i}$$

Solve for the focal length.  $f =$  \_\_\_\_\_

#### II. FOCAL LENGTH BY PLOTTING $1/d_o$ vs. $1/d_i$

- a. On the optical bench, position the lens between a light source (the object) and a screen. Be sure the object and the screen are at least one meter apart.
- b. Move the lens to a position where an image of the object is formed on the screen. Measure the image distance and the object distance. Record all measurements in table 9.1.
- c. Measure the object size and the image size for this position of the lens.
- d. Move the lens to a second position where the image is in focus (Do not move the screen or Light Source). Measure the image distance and the object distance.
- e. Measure the image size for this position also.
- f. Move the screen toward the object until you can no longer find two positions of the lens where the image will focus. Then move the screen a few centimeters further away from the object. Repeat Parts b and d for this position of the screen and for 4 other intermediate positions of the screen. This will give you 6 sets of data points (a total of 12 data points).

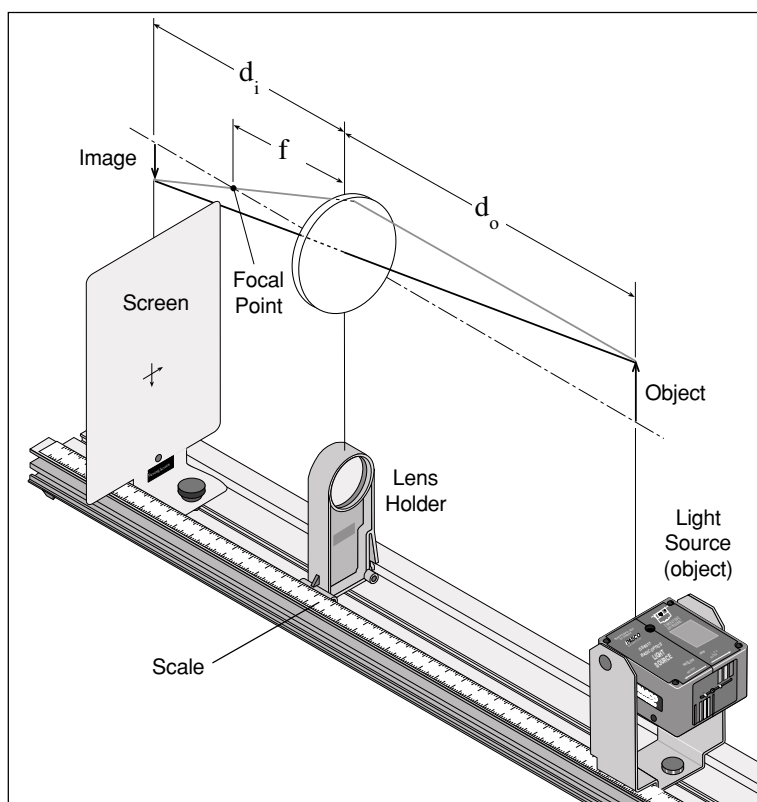

Figure 9.1

- g. Plot  $1/d_o$  vs.  $1/d_i$  using the 12 data points. This will give a straight line and the x- and y- intercepts are each equal to  $1/f$ .
- h. Find the percent difference between the two values of the focal length found from the intercepts. Then average these two values and find the percent difference between this average and the focal length found in Part I.
- i. For the first two sets of data points ONLY, use image and object distances to find the magnification at each position of the lens.

$$\text{Magnification} = M = \frac{d_i}{d_o}$$

Then, using your measurements of the image size and object size, find the magnification by measuring the image size and the object size.

$$|M| = \frac{\text{image size}}{\text{object size}}$$

Find the percent differences.

**Table 9.1**

Object distance	Image distance	Image size	$1/d_o$	$1/d_i$
1				
2				
3				
4				
5				
6				
7				
8				
9				
10				
11				
12				

x – intercept \_\_\_\_\_

y – intercept \_\_\_\_\_

$f_{\text{average}}$  \_\_\_\_\_

percent difference \_\_\_\_\_

**QUESTIONS**

- ① Is the image formed by the lens erect or inverted?
- ② Is the image real or virtual? How do you know?
- ③ Explain why, for a given screen–object distance, there are two positions where the image is in focus.
- ④ Why is the magnification negative?



## Experiment 10: Telescope

### EQUIPMENT NEEDED

- Bench (OS-8518) – 2 convex lenses (focal lengths 10 cm and 20 cm)
- Screen with paper pattern (See back of manual for pattern) – Metric rule

### Purpose

To construct a telescope and determine the magnification.

### Theory

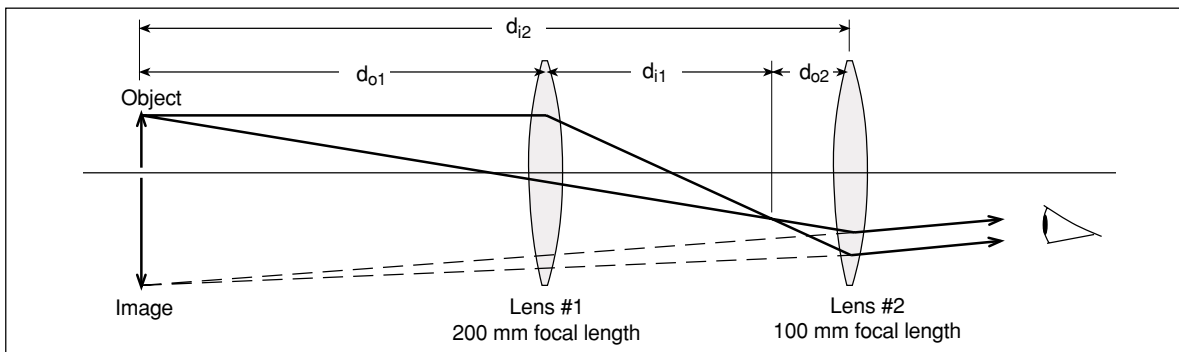

**Figure 10.1**

An astronomical telescope is constructed with two convex lenses. The ray diagram for this experiment (shown in Figure 10.1) indicates that the image is in the same plane as the object. Having the image in the same plane as the object allows the distance to the virtual image to be determined. For this experiment, it is assumed that the lenses are thin compared to the other distances involved. In this case the Thin Lens Formula may be used. This equation states:

$$\frac{1}{f} = \frac{1}{d_o} + \frac{1}{d_i}$$

where  $f$  is focal length,  $d_o$  is the distance between the object and the lens, and  $d_i$  is the distance between the image and the lens.

The magnification of a two-lens system is equal to the multiplication of the magnifications of the

individual lenses:

$$M = M_1 M_2 = \left( \frac{-d_{i1}}{d_{o1}} \right) = \left( \frac{-d_{i2}}{d_{o2}} \right)$$

### Set Up

- ① Tape or use paper clips to fasten the paper pattern to the screen. The crosshatching on the screen acts as the object.
- ② The 200 mm lens is the objective lens (the one which is nearer to the object). The 100 mm lens is the eyepiece lens (the one which is nearer to the eye). Place the lenses near one end of the optical bench and place the screen on the other end. See Figure 10.2.

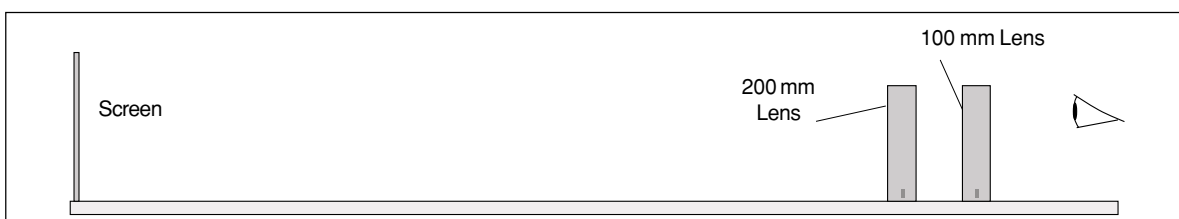

**Figure 10.2**

## Procedure

- ① Focus the image of the object (the crosshatching on the screen) by moving the objective lens (the one which is closer to the object). To view the image, you must put your eye close to the eyepiece lens.
- ② Eliminate the parallax by moving the eyepiece lens until the image is in the same plane as the object (screen). To observe the parallax, open both eyes and look through the lenses at the image with one eye while looking around the edge of the lenses directly at the object with the other eye. See Figure 10.3. The lines of the image (solid lines shown in Figure 10.4 inset) will be superimposed on the lines of the object (shown as dotted lines in Figure 10.4 inset). Move your head back-and-forth or up-and-down. As you move your head, the lines of the image will move relative to the lines of the object due to the parallax. To eliminate the parallax, move the eyepiece lens until the image lines do not move relative to the object lines when you move your head. When there is no parallax, the lines in the center of the lens appear to be stuck to the object lines.

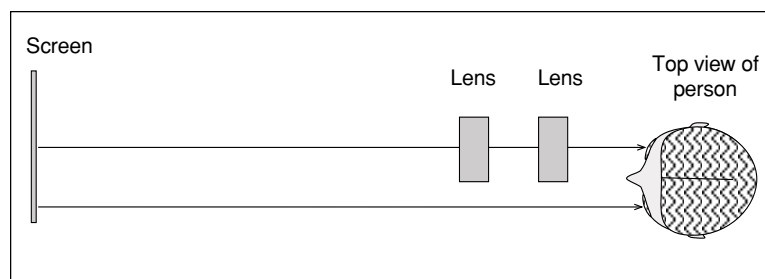

**Figure 10.3**

**NOTE:** Even when there is no parallax, the lines may appear to move near the edges of the lens because of lens aberrations.

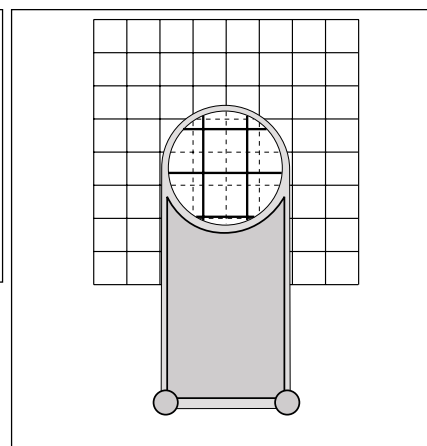

**Figure 10.4**

- ③ With the parallax now eliminated, the virtual image is now in the plane of the object. Record the positions of the lenses and the object in Table 10.1.
- ④ Measure the magnification of this telescope by counting the number of squares in the object that lies along one side of one square of the image. To do this, you must view the image through the telescope with one eye while looking directly at the object with the other eye. Record the observed magnification in Table 10.1.
- ⑤ Remove the screen and look through the lenses at a distant object such as a meter stick at the opposite side of the room. Eliminate the parallax and determine the magnification. When viewing an object at infinity through a telescope, the magnification is the ratio of the focal lengths of the lenses. Check to see if this is true for your telescope.

## Analysis

To calculate the magnification complete the following steps and record the answers in Table 10.1:

- ① Determine  $d_{o1}$ , the distance from the object (paper pattern on screen) to the objective lens.
  - ② Determine  $d_{i2}$ , the distance from the eyepiece lens and the image. Since the image is in the plane of the object, this is also the distance between the eyepiece lens and the object (screen).
  - ③ Calculate  $d_{i1}$  using  $d_{o1}$  and the focal length of the objective lens in the Thin Lens Formula.
  - ④ Calculate  $d_{o2}$  using  $d_{i2}$  and the focal length of the eyepiece lens in the Thin Lens Formula.
  - ⑤ Calculate the magnification using:
- ⑥ Take a percent deviation between this value and the observed value.

**Table 10.1 Results**

Position of Objective Lens (200 mm)	
Position of Eyepiece Lens (100 mm)	
Position of Screen	
$M = M_1 M_2 = \left( \frac{-d_{i1}}{d_{o1}} \right) \left( \frac{d_{i2}}{d_{o2}} \right)$ Observed Magnification	
$d_{i2}$	
$d_{i1}$	
$d_{o2}$	
Calculated Magnification	
Percent Difference	

## Questions

- ① Is the image inverted or erect?
- ② Is the image seen through the telescope real or virtual?

***Notes:***

## Experiment 11: Microscope

### EQUIPMENT NEEDED

- Bench (OS-8518)
- 2 convex lenses
- Screen with paper pattern (See back of manual for pattern)
- Metric rule

### Purpose

To construct a microscope and determine the magnification.

### Theory

A microscope magnifies an object that is close to the microscope. The ray diagram for this experiment (shown in Figure 11.1) indicates that the image is in the same plane as the object. Having the image in the same plane as the object allows the distance to the virtual image to be determined.

For this experiment, it is assumed that the lenses are thin compared to the other distances involved. In this case the Thin Lens Formula may be used. This equation states

where  $f$  is focal length,  $d_o$  is the distance between the object and the lens, and  $d_i$  is the distance between the image and the lens. The magnification of a two-lens system is equal to the multiplication of the magnifications of the individual lenses:

$$\frac{1}{f} = \frac{1}{d_o} + \frac{1}{d_i}$$

$$M = M_1 M_2 = \left( \frac{-d_{i1}}{d_{o1}} \right) \left( \frac{-d_{i2}}{d_{o2}} \right)$$

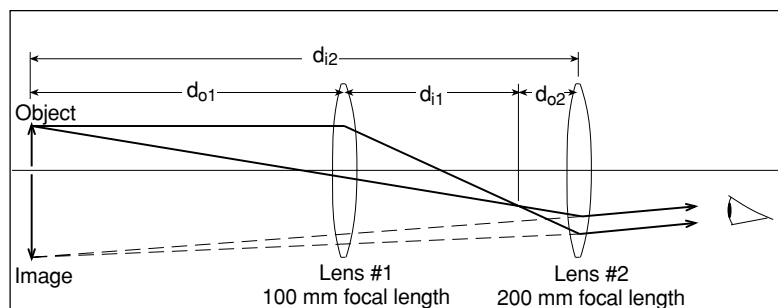

Figure 11.1

### Set Up

- ① Tape or use paper clips to fasten the paper pattern to the screen. The crosshatching on the screen acts as the object.
- ② The 100 mm lens is the objective lens (the one which is nearer to the object). The 200 mm lens is the eyepiece lens (the one which is nearer to the eye). Place the lenses near one end of the optical bench and place the screen about in the middle of the optical bench. See Figure 11.2.

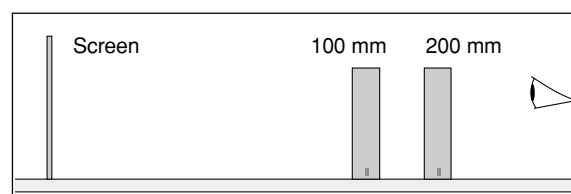

Figure 11.2

### Procedure

- ① Focus the image of the object (the crosshatching on the screen) by moving the objective lens (the one which is closer to the object). To view the image, you must put your eye close to the eyepiece lens.
- ② Eliminate the parallax by moving the eyepiece lens until the image is in the same plane as the object (screen). To observe the parallax, open both eyes and look through the lenses at the image with one eye while looking around the edge of the lenses directly at the object with the other eye. See Figure 11.3. The lines of the image (solid lines shown in Figure 11.4 inset) will be superimposed on the lines of the object (shown as dotted lines in Figure 11.4 inset). Move your head back-and-forth or up-and-down. As you move your head, the lines of the image will move relative to the lines of the object due to the parallax. To eliminate the parallax, move the eyepiece lens until the image lines do not move relative to the object lines when you move your head. When there is no parallax, the lines in the center of the lens appear to be stuck to the object lines.

**NOTE:** Even when there is no parallax, the lines may appear to move near the edges of the lens because of lens aberrations.

- ③ With the parallax now eliminated, the virtual image is now in the plane of the object. Record the positions of the lenses and the object in Table 11.1.
- ④ Measure the magnification of this microscope by counting the number of squares in the object that lies along one side of one square of the image. To do this, you must view the image through the microscope with one eye while looking directly at the object with the other eye. Record the observed magnification in Table 11.1.

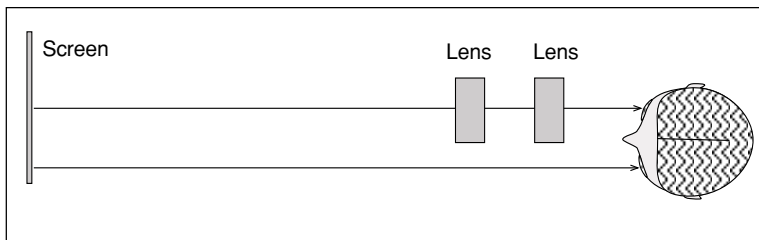

Figure 11.3

**Analysis**

To calculate the magnification complete the following steps and record the answers in Table 10.1:

- ① Determine  $d_{o1}$ , the distance from the object (paper pattern on screen) to the objective lens.
- ② Determine  $d_{i2}$ , the distance from the eyepiece lens and the image. Since the image is in the plane of the object, this is also the distance between the eyepiece lens and the object (screen).
- ③ Calculate  $d_{i1}$  using  $d_{o1}$  and the focal length of the objective lens in the Thin Lens Formula.
- ④ Calculate  $d_{o2}$  using  $d_{i2}$  and the focal length of the eyepiece lens in the Thin Lens Formula.
- ⑤ Calculate the magnification using:
- ⑥ Take a percent deviation between this value and the observed value.

**Table 11.1 Results**

Position of Objective Lens	
Position of Eyepiece Lens	
Position of Screen	
Observed Magnification	
$d_{o1}$	
$d_{i2}$	
$d_{i1}$	
$d_{o2}$	
Calculated Magnification	
Percent Difference	

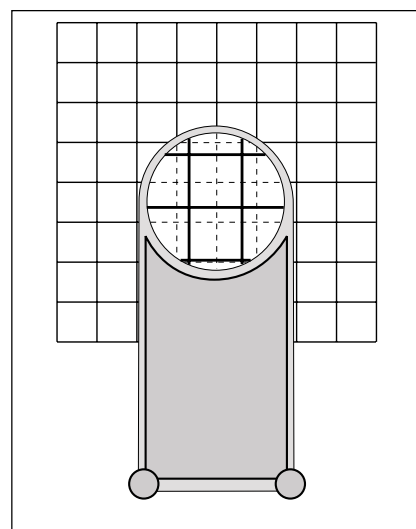

Figure 11.4

**Questions**

- ① Is the image inverted or erect?
- ② Is the image seen through the microscope real or virtual?

## Experiment 12: Shadows

### EQUIPMENT NEEDED

- 2 Optics benches (OS-8518)
- 2 point light sources (OS-8517)
- Screen
- A pencil to use as the object that casts the shadow

### Purpose

To show the umbra (dark) and the penumbra (lighter) parts of the shadow.

### Set Up

- ① Place the two optics benches beside each other.
- ② Put one point light source on each bench as shown in Figure 12.1.
- ③ Place the screen on the other end of the track, opposite the light sources.

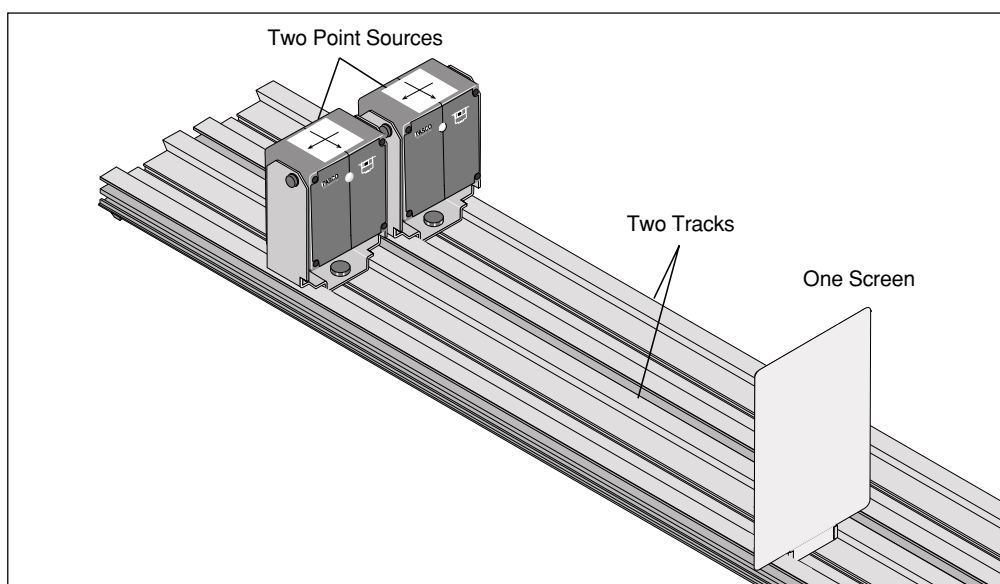

**Figure 12.1**

### Procedure

- ① Plug in only one of the light sources.
- ② Hold the pencil about 5 cm away from the screen so its shadow is cast on the screen. Now change the light source from the point source position to the broader crossed-arrow position. How does the shadow change?
- ③ Rotate the light source back to the point source position. Plug in the second point light source. Make a sketch of the shadow of the pencil. Label the umbra and the penumbra.
- ④ Move the pencil away and toward the screen. How does the shadow change?
- ⑤ Block the light from each point source in succession to determine which part of the shadow is caused by each light source.

***Notes:***



## Experiment 13: Inverse Square Law

### EQUIPMENT NEEDED

- Bench (OS-8518)
- 2 Point Light Sources (OS-8517)
- Photometer with Filter Set (OS-8520)

### Purpose

The purpose of this experiment is to show that light intensity is inversely proportional to the square of the distance from a point light source.

### Theory

The light from a point light source spreads out uniformly in all directions. The intensity at a given distance,  $r$ , from the light will be equal to the power output of the light divided by the surface area of the sphere through which the light has spread. Since the area of the sphere goes as the square of its radius,  $r$ , the intensity will drop off as  $1/r^2$ . In general, the intensity of the point light source at any distance,  $r$ , is given by

Thus, the ratio of the intensity ( $I$ ) of the light at a position ( $r$ ) as compared to the reference intensity ( $I_o$ ) measured at a position ( $r_o$ ) is given by

$$\frac{I}{I_o} = \frac{r_o^2}{r^2}$$

$$I = \frac{\text{constant}}{r^2}$$

### Set Up

- ① Place the photometer at the 70 cm mark on the optics bench.
- ② Place a point light source at 40 cm. Put a neutral density filter on the side of the photometer that is opposite the point source. See Figure 13.1. Place the other light source on the same side of the bench that has the neutral density filter.

**NOTE:** This experiment can be done using one point light source and a second light source (used as a reference) that is not a point source. If you are using only one point source, put the point source on the side of the photometer that does not have the filter.

- ③ Adjust the neutral density filter for 100% transmittance.

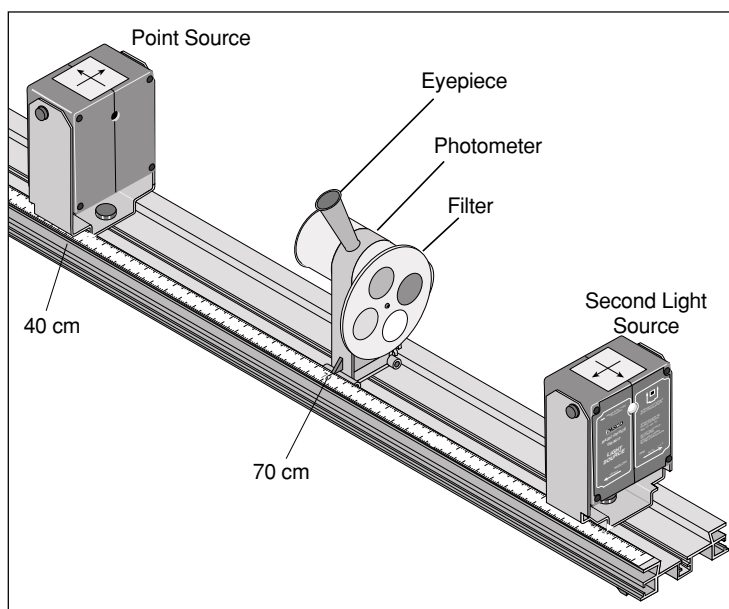

Figure 13.1: Experiment Set-Up

## Procedure

**NOTE:** You may want to cover the crossed-arrow object on each light source to reduce the excess light in the room. The room lights must be off for this experiment.

- ① Turn off the room lights. The only sources of light should be the two point sources.
- ② Look into the photometer and move the light source on the filter side to a position that gives equal intensities. The light source on the filter side will remain at this position for the rest of the experiment. This light will act as the reference intensity  $I_o$ . Record the positions of the photometer and the light source that is opposite the filter side of the photometer in Table 13.1. The position of the reference light (on the filter side) is not needed.
- ③ Rotate the neutral density filter to 75% transmittance. Move the point light source (the one opposite to the filter side) the position where the intensities are once again the same when viewed in the photometer. Record this new position of the light source in Table 13.1.
- ④ Repeat the last step for 50% and 25% transmittance.

**Table 13.1: Positions**

Colors Added	Resulting Color
red+blue+green	white
red+blue	purple
red+green	orange
green+blue	bluish-green

## Analysis

- ① Using the measured positions in Table 13.1, calculate the distances of the point source from the photometer and record in Table 13.1.
- ② For each of the different positions, calculate the intensity using

$$I = \left(\frac{r_o}{r}\right)^2 I_o$$

where  $r_o$  is the initial distance of the point source (100%) and  $r$  is the distance at the given intensity. Note that the intensity is calculated in terms of the initial intensity  $I_o$ . Record your answers in Table 13.1.

- ③ Calculate the percent difference between the calculated intensities and their corresponding expected values. Record in Table 13.1.

## Experiment 14: Polarization

### EQUIPMENT NEEDED

- Optics bench (OS-8518)
- 2 Point light sources (OS-8517)
- Photometer with filter set (OS-8520)
- 2 Polarizers (OS-8520)

### Purpose

The purpose of this experiment is to show that the intensity of the transmitted light through two polarizers depends on the square of the cosine of the angle between the axes of the two polarizers.

### Theory

A polarizer only allows light which is vibrating in a particular plane to pass through it. This plane forms the “axis” of polarization. Unpolarized light vibrates in all planes. Thus if unpolarized light is incident upon an “ideal” polarizer, only half will be transmitted through the polarizer. (Since in reality no polarizer is “ideal”, less than half the light will be transmitted.) The transmitted light is polarized in one plane. If this polarized light is incident upon a second polarizer, the axis of which is oriented such that it is perpendicular to the plane of polarization of the incident light, no light will be transmitted through the second polarizer (Figure 14.1).

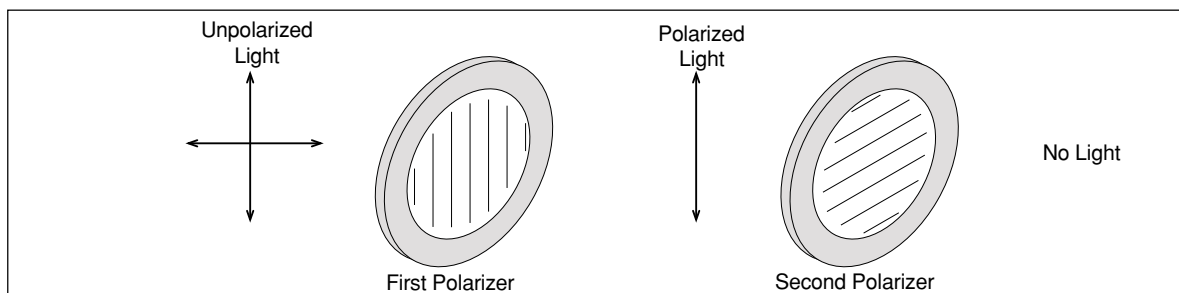

**Figure 14.1: Unpolarized light incident on two polarizers oriented perpendicularly to each other.**

However, if the second polarizer is oriented at an angle so that it is not perpendicular to the first polarizer, there will be some component of the electric field of the polarized light that lies in the same direction as the axis of the second polarizer, and thus some light will be transmitted through the second polarizer (Figure 14.2).

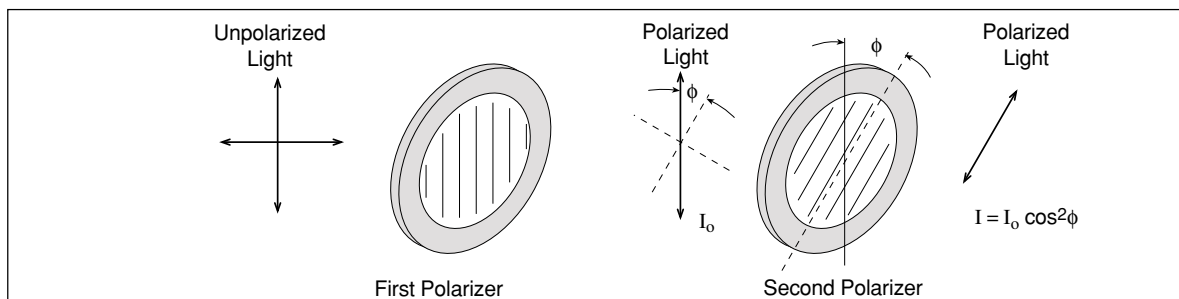

**Figure 14.2: Unpolarized light incident on two polarizers oriented at an angle  $\phi$  with respect to each other.**

The component,  $E$ , of the polarized electric field,  $E_0$ , is found by using trigonometry:  $E = E_0 \cos\phi$ . Since the intensity of the light goes as the square of the electric field, the transmitted light intensity is given by  $I = I_0 \cos^2\phi$ , where  $I_0$  is the incident light intensity and  $\phi$  is the angle between the axis of polarization of the incident light and the polarizer.

Notice that the two extremes work in this formula:

- ① If  $\phi$  is zero,  $\cos^2(\phi)$  equals one, and thus the intensity transmitted is equal to the incident intensity of the polarized light because the polarizer is aligned with the incident light and will allow all of it to pass through.

**NOTE:** It is assumed that the incident light is polarized, not unpolarized.

- ② If  $\phi$  is  $90^\circ$ ,  $\cos^2(\phi)$  equals zero, and no light is transmitted since the polarizer is oriented perpendicular to the plane of polarization of the incident light.

## Set Up

- ① Place the photometer in the middle of the optics bench. Place the neutral density filter on one side of the photometer. See Figure 14.3.
- ② Place a point light source on each end of the optics bench.
- ③ Snap one polarizer onto each side of the accessory holder. Before beginning the experiment, check the angle calibration on the polarizers in the following way: On the side of the accessory holder that has the label, set the angle to  $90^\circ$ . Look through both polarizers at a bright light and rotate the other polarizer until the transmitted light is at the minimum. Now the polarizers are crossed at  $90^\circ$ . Rotate the label-side polarizer back to zero degrees. Now the two polarizers are aligned for maximum transmission. Throughout the experiment, only rotate the label-side polarizer.
- ④ Place the polarizer accessory holder (with polarizers) on the bench between the light source and the photometer on the side opposite the neutral density filter. The label side of the polarizer holder should face away from the photometer. The polarizer holder should be close to the photometer so only polarized light will enter that side of the photometer.

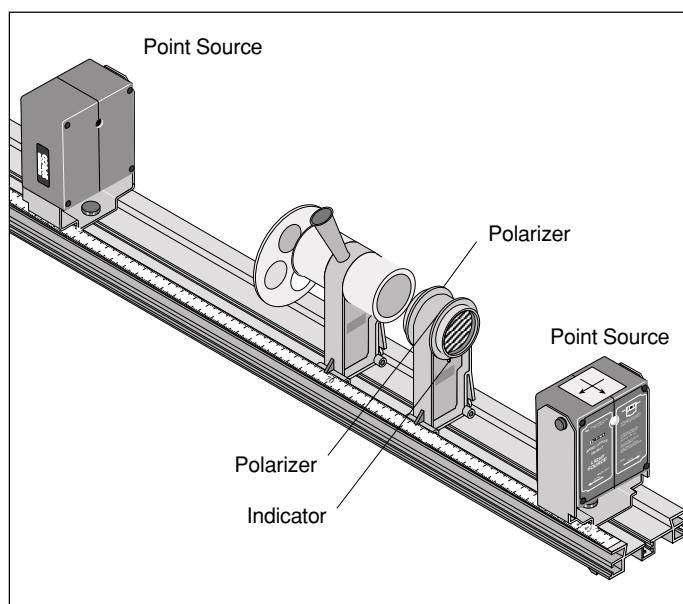

Figure 14.3: Experiment Set-Up

## Procedure

**NOTE:** You may want to cover the crossed-arrow objects on each light source to reduce the excess light in the room. The room lights must be off for this experiment.

- ① Set the neutral density filter for 100% transmission.
- ② While looking into the photometer's conical eyepiece, adjust the position(s) of the light source(s) until the two sides of the orange indicator have equal intensity.
- ③ Set the neutral density filter for 75% transmission.
- ④ While looking into the photometer's conical eyepiece, rotate the label-side polarizer until the two sides once again have equal intensity. Record the angle in Table 14.1. Rotate the polarizer back to zero and repeat the measurement two more times.
- ⑤ Repeat the previous step for 50% and 25% transmission.

**Table 14.1: Data and Results**

% transmittance	75%	50%	25%
trial 1			
trial 2			
trial 3			
Average angle			
$\cos^2\phi$			
% difference			

## Analysis

- ① For each of the neutral density filter settings, calculate the average of the three trials and record the average angle in Table 14.1.
- ② To calculate the predicted percent transmittance for each case, calculate the square of the cosine of each average angle and record in Table 14.1.
- ③ Calculate the percent difference between the percentage transmittance and the predicted value for each case and record in Table 14.1.

**Grid:**

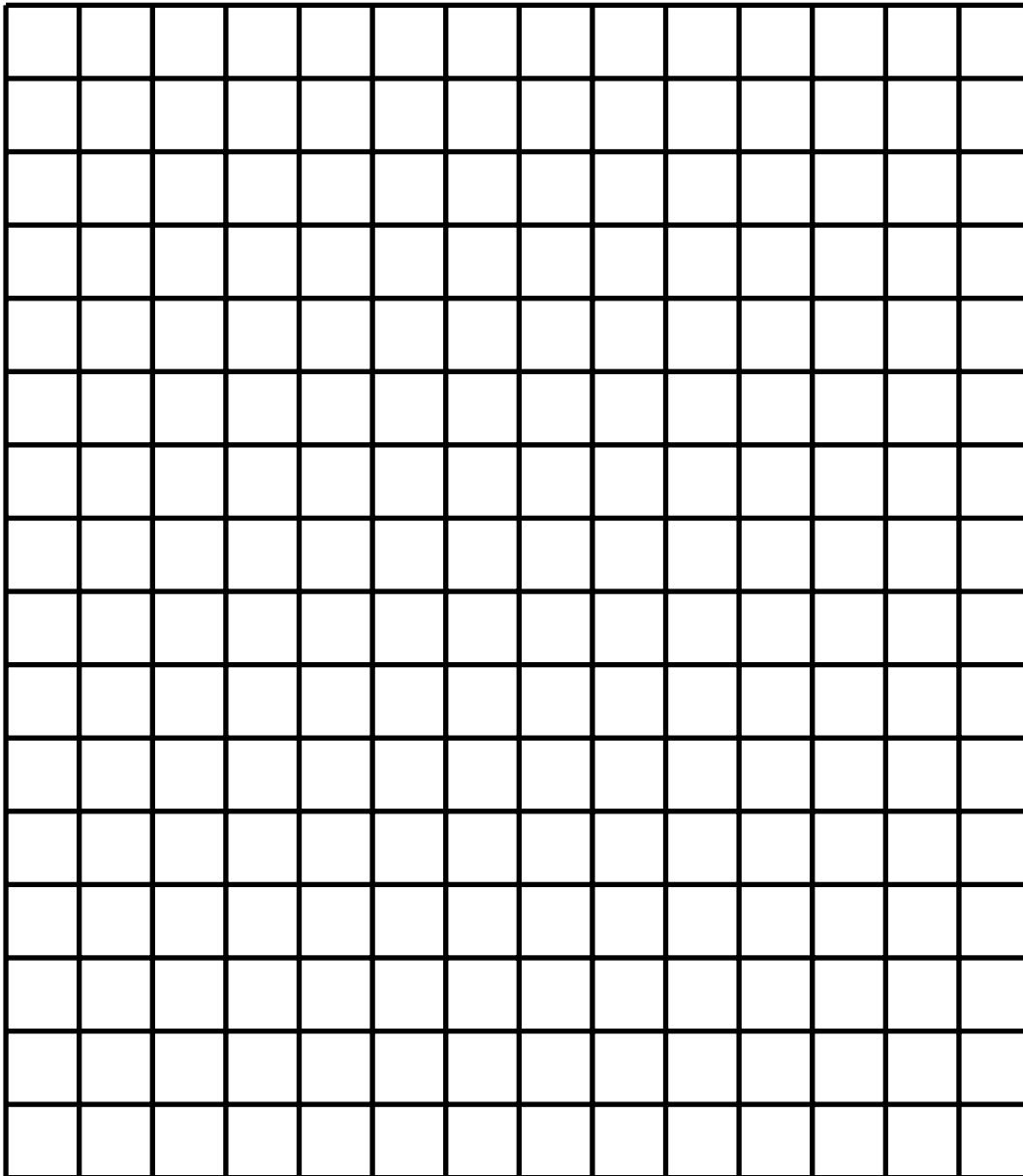

### Experiment 7: Lensmaker's Equation

#### Notes on Experiment

Measured Focal Length: 12.0 cm

Measured Radius of Curvature =  $-6.0 * 2 = -12.0$  cm

Calculated Focal Length:  $1/f = (n - 1) * (1/R1 + 1/R2)$   
 $= (1.5 - 1) * (1/(-12) + 1/(-12))$   
 $= (.5)(-1/6) = -.0833$

So,  $f = -12.1$  cm

% Difference:  $(-12.1 - (-12.0))/(-12.1) * 100 = .83\%$

#### Notes on Questions

The focal length of a concave lens is negative.

The thicker lensmaker formula is an approximation for thin lenses. The thicker the lens, the worse the approximation.

### Experiment 8: Apparent Depth

#### Notes on Experiment Part I

Apparent Depth,  $d = 2.2$  cm

Thickness,  $t = 3.1$  cm

Index of Refraction,  $n = t/d = 3.1 \text{ cm} / 2.2 \text{ cm} = 1.41$

% Difference =  $(1.5 - 1.41) / 1.5 * 100 = 6\%$

#### Notes on Experiment Part II

$x = 1.0$  cm

$n = 1 / (1 - x/t) = 1 / (1 - 1.0/3.1) = 1.48$

% Difference =  $(1.5 - 1.48) / 1.5 * 100 = 1.3\%$

### Experiment 9: Focal Length of a Thin Lens

#### Notes on Procedure:

It is recommended that you use either the +100 or +200 lenses for this experiment.

#### Analysis:

Screen distance	d1	d0	Image height	di	do	Image height
110.0	26.1	83.9	0.95	83.7	26.3	9.4
82.0	34.1	47.9	2.1	47.8	34.2	4.2
87.0	31.0	56.0	1.7	55.8	31.2	5.3
92.0	29.3	62.7	1.4	62.6	29.4	6.3
99.0	27.8	71.2	1.2	71.2	27.8	7.6
104.0	27.1	76.9	1.0	76.9	27.1	8.4