



inclusive play
design guide







inclusive play **design guide**[®]

Foreword	iii
● Introduction	1
● Playground Standards.....	3
● Planning & Preparation	7
● Layout	17
● Access	25
● Play Richness	31
● Selecting Playground Equipment.....	41
● Support Features.....	47
Glossary	54
Surfacing Appendix.....	57
Work Group & Reviewers.....	60
Resources.....	63

Foreword

This Inclusive Play Design Guide (Design Guide) has been developed by a group of playground and child development experts as an inspirational resource to guide the creation of great outdoor play environments for everyone.

Everyone

“Everyone” meaning:

- Typically developing children
- Children with neurological disabilities such as autism
- Children who have intellectual disabilities such as Down syndrome, fetal alcohol syndrome
- Children who require wheelchairs or other medical equipment
- Children with physical disabilities
- Children with social and/or emotional difficulties
- Family, siblings, parents, grand-parents etc.
- The community: friends, caregivers, teachers, etc.
- Adults with disabilities



12%

This design guide is essential for the future of playground design when considering the high number of people affected by disability in the United States. According to the United States Census, 12% of the population has a severe disability that affects at least one function of daily living. But this group of people does not live in a vacuum; they have parents, siblings and grandparents who are involved in their daily lives. So in actuality, more than 36% of the population is touched by severe disability – 1 in 3 people. Disability challenges how affected individuals and their families go to school, go to work, and even spend the day at a park.

The authors of this document, the Inclusive Play Design Guide Work Group, hope that this guide will inspire others to build environments that allow better access to play, which will in turn enrich our society.



inclusive play
design guide

INTRODUCTION



Design Guide FAQ

WHAT IS AN INCLUSIVE PLAYGROUND?

An inclusive playground addresses the needs of all people including those who have autism, intellectual disabilities, hearing impairments, cerebral palsy, spina bifida and other disabilities. It also addresses the needs of typical children. An inclusive playground accommodates everyone and challenges them at their own developmental level.

WHAT IS THE PURPOSE OF THE DESIGN GUIDE?

To offer inspiration and guidance to support the design of an inclusive, universally designed outdoor playground.

WHO IS THE DESIGN GUIDE FOR?

People who care about inclusion and aim to create a play space in their community for people of all ages and abilities.

HOW TO USE THE DESIGN GUIDE

The Design Guide includes best practices for the planning and development of outdoor inclusive play.

Each of the chapters is divided into several categories. Each category outlines “intents” and “strategies”.

- Intents = Goals
- Strategies = Implementation tactics

The Intents create a composite picture of an inclusive play space. The identified strategies are suggestions on how to meet each intent.

THE DESIGN GUIDE IS NOT A RULEBOOK

As a decision maker or designer of a playground, you may choose to emphasize one Intent over another, or create a strategy of your own to achieve an intent not mentioned here.

Make these decisions consciously, with an understanding of the tradeoffs and consequences.

HOW WAS THE DESIGN GUIDE DEVELOPED?

The Design Guide was developed through a consensus-based process and led by a work group of industry professionals. This diverse group of individuals represents a cross-section of child development, inclusive advocacy, landscape architecture and playground industry expertise. In addition, the majority of the work group are parents to a child with a disability. *(See page 59 for further descriptions of the work group.)*

WHY IS THIS DESIGN GUIDE NECESSARY?

Regardless of the best intentions, interesting products placed together on the playground do not make it inclusive. Designers must be mindful of the impact individual decisions make to the entire experience. From the directional signage to the overall playspace layout. From the location of sound-making events to the location of benches, accessible routes and perimeter fencing, all these have impact on certain users.

This Design Guide attempts to inspire and educate people on their journey to inclusive play with the hope that individual decisions are made with an understanding of the effect of that decision for everyone.



inclusive play
design guide

PLAYGROUND STANDARDS

“If I have seen further it is by standing on the shoulders of giants.” -Isaac Newton

The Design Guide is meant to add to the knowledge built by other advancements in the in the outdoor play industry. The goal of this section is to raise awareness of those developments and standards.

This Design Guide is designed to be used in conjunction with guidelines and laws that exist to advance inclusion and safety in the playground. Any recommendations made in this guide do not supersede the requirements listed below.

This section also provides information for guidelines and standards for other countries. Check with the local officials prior to designing the playground to ensure the playground design complies with all regulations.

UNITED STATES GUIDELINES AND LAWS

AMERICANS WITH DISABILITIES ACT (ADA)

<http://www.access-board.gov/>

ADA is a wide-ranging US civil rights law that prohibits discrimination based on disability. Disability is defined by the ADA as “a physical or mental impairment that substantially limits a major life activity.”

Section 240 of the 2010 Standards—This section discusses modifications to existing play components and playgrounds, and provides information on the minimum number and types of play components required.

Section 1008—This section addresses the requirements for accessible ground surfaces including accessible routes and turning space.

AMERICAN SOCIETY FOR TESTING AND MATERIALS (ASTM)

<http://www.astm.org/Standards/F1487.htm>

<http://www.astm.org/Standards/F1292.htm>

ASTM International, formerly known as the American Society for Testing and Materials (ASTM), is a globally recognized leader in the development and delivery of international voluntary consensus standards

The standards that must be followed for playgrounds are: ASTM F1487-11 - Standard Consumer Safety Performance Specification for Playground Equipment for Public use. As well as ASTM F1292-09 - Standard Specification for Impact Attenuation of Surface Materials within the Use Zone of the Playground Equipment.

THE U.S. CONSUMER PRODUCT SAFETY COMMISSION (CPSC)

<http://www.cpsc.gov/CPSCPUB/PUBS/325.pdf>.

The CPSC is charged with protecting the public from unreasonable risks of injury or death from thousands of types of consumer products under the agency’s jurisdiction. They publish the “Public Playground Safety Handbook”

Because many factors affect playground safety, the CPSC staff believes that guidelines, rather than a mandatory rule, are appropriate. These guidelines are not being issued as the sole method to minimize injuries associated with playground equipment, but as one resource to consider. The Commission believes that the recommendations in Public Playground Safety Handbook together with the technical information in the ASTM standards will contribute to greater playground safety.

Assistance on can be received from The National Parks and Recreation Association (www.nrpa.org) They have a registry of local Certified Playground PSIs.

Some communities mandate compliance with CPSC. **Communities may also have local ordinances. Check with the local officials prior to designing the playground to ensure the playground design complies with all regulations.**

CANADIAN GUIDELINES & LAWS

CANADIAN STANDARDS ASSOCIATION (CSA)

<http://www.csa.ca/cm/ca/en/home>

Fourth edition of CSA Z614-07 Children's Playspaces and Equipment is the current Canadian playground safety standard

The Canadian Standards Association (CSA) has developed the only nationally recognized standard on children's play spaces and equipment. The CSA Standard provides detailed information about materials, installation, strength of the equipment, surfacing, inspection, maintenance, performance requirements, and access to the playground, play space layout, and specifications for each type of equipment.

The standards are voluntary and are not a law. The standards apply to public playgrounds, such as those on school grounds, in parks, or at day care centers or motels. It does not apply to private, residential (home) playgrounds or indoor facilities. There is no national enforcement body for playground safety; however, some jurisdictions in Canada have passed regulations requiring public playground operators to ensure that their playgrounds meet the CSA Standard. For example, in some provinces, playgrounds at day care centers may be required to meet the standard in order for the center to get an operating license. The standards are not retroactive and only apply to play spaces and equipment installed after the date the Standard was published. The CSA does not certify playgrounds or specific pieces of play equipment.

OTHER COUNTRIES

EUROPEAN TECHNICAL STANDARDS

<http://www.en-standard.eu>

Safety standards related to public playground environments, playground equipment and surfacing standards:

- EN 1176-1 : Part 1: General safety requirements and test methods,
- EN 1176-2 : Part 2: Additional specific safety requirements and test methods for swings
- EN 1176-3 : Part 3: Additional specific safety requirements and test methods for slides
- EN 1176-4, EN 1176-5, EN 1176-6, EN 1176-7, EN 1176-10, EN 1176-11, EN 1177

STANDARDS AUSTRALIA

<http://standards.com.au>

Standards Australia is recognized by the Government as Australia's peak Standards body. It coordinates standardization activities, develops internationally aligned Australian Standards® and facilitates the accreditation of other Standards Development Organizations. Through the Australian International Design Awards it promotes excellence in design and innovation for public play areas including guidance for labeling and maintenance of playground equipment, moveable play equipment and exercise equipment to minimize potential hazards. Also makes recommendations for the provision of impact absorbing surfaces, and the siting of play and exercise equipment, as well as indoor play areas and their surroundings.

DR 91167 Playgrounds and playground equipment - Public use AS 4685-2004 Sections 1 through 6 -

Playground equipment - particular safety requirements and test methods for specific pieces of equipment

SINGAPORE PLAYGROUND STANDARDS

stn@spring.gov.sg

SS 457 : 2007 Specification for Playground Equipment for Public Use

This Singapore Standard was prepared by a Working Group appointed by the Technical Committee on General Safety under the direction of the Industrial Safety Standards Committee. It supersedes the section on playground equipment specified in SS 223 : 1979 - 'Safety requirements for children's toys and playthings'.



This Singapore Standard specifies safety requirements for outdoor playground equipment. The aim is to reduce potential hazards in such equipment itself thereby reducing the risk of injury to children who use it. This standard covers hazards involving impact by swings and other moving equipment and contact with protrusions, pinch points and sharp edges.



inclusive play
design guide

PLANNING & PREPARATION



PLANNING & PREPARATION (PP)

DEFINITION:

This section will help someone who wants to build an inclusive playground by offering ideas on the community-based work of planning and building an inclusive playground.

INTENT:

To provide a series of options for the process of planning the playground project.

CONTENTS:	PAGE
PP-1 Planning Committee Membership	9
PP-2 Committee Lifespan	10
PP-3 Financial Planning	10
PP-4 Outreach	12
PP-5 Experts	13
PP-6 Mission & Vision	13
PP-7 Timelines.....	13
PP-8 Site Selection.....	14
PP-9 Site Preparation.....	15

NOTE:

Substantial portions of this chapter have been contributed by KaBOOM!, a non-profit organization dedicated to creating playgrounds with walking distance of every child.

PP-1 | PLANNING COMMITTEE MEMBERSHIP

INTENT

A planning committee increases the chances of success by spreading out the responsibilities, increases the diversity of ideas from which to choose and increases the chances of buy-in by the user groups and the surrounding community.

STRATEGIES

Consider including on the planning committee:

- People in the community with disabilities as well as parents who are raising children with disabilities
- Accessibility experts
- People from the neighborhood, or the wider community
- Site professionals such as landscape architects
- Local government officials or employees
- Playground professionals
- The owner/operator of the land
- Parents of typically developing children.
- Include the entire community. People of all ages, all the family, must have something to do
- Children, and their parents, with different disabilities
- Personnel and parents from the local schools, special education schools, non-profit organizations that work with children who have disabilities.
- People who will be responsible for maintenance once the playground is open
- Other stakeholders. Whose agreement would be desired or needed?

Between the parents, accessibility experts, school personnel and nonprofit workers, try to get expertise in at least the following disabilities: visual impairment, hearing impairment, autism/SPD, mobility impairment, and cognitive disabilities.

KaBOOM!, a leader in community build playgrounds (see glossary), suggests setting up your committee as follows:

Two Co-Chairs — The co-chairs are the coordinators and leaders of the entire playground project. Co-chairs should have adequate time available to lead this project, and be organized and resourceful.

Recruitment Team Captain — This captain is responsible for recruiting volunteers to build the playground. It is an exciting and challenging task that demands a “people person” who isn’t afraid to ask others to lend a helping hand.

Children’s Team Captain — This captain will develop ways for children to participate in the project from the beginning to the end. He/she should be creative, responsible and good with children.

Construction Team Captain — The goal of this team captain is to prepare for and facilitate the building of the playground, acquiring the tools and materials needed.

Fundraising Team Captain — This captain is in charge of raising money for the project at grass-roots and corporate levels. The more money raised by the community, the more people will feel invested in the project. The Fundraising Captain also acts as a treasurer and tracks the project’s budget.

Food Team Captain — The way to a volunteer’s heart is through the stomach! This captain is responsible for launching an all-out effort to feed the volunteers on Build Day, which can include

breakfast, lunch, snacks and lots of water. Someone who can solicit in-kind donations from local grocers or restaurants with ease should be considered.

Public Relations Team Captain — This person will generate all the press and publicity that lets the wider community, city or state support your project and celebrate your accomplishments.

Safety Team Captain — This captain plays an essential role on build day. He/she creates an environment on the playground work site where everyone can work hard without worrying about unsafe conditions or accidents. This individual is someone who can work with all age groups, is understanding, and is not afraid to speak up for safety's sake.

PP-2 | COMMITTEE LIFESPAN

INTENT

Ensure continuity during the life of the project.

STRATEGIES

- Ensure that the committee stays in place from inception to conclusion.
- Try to minimize committee turnover by involving everyone in the activities of the committee, making progress toward the goals and allowing people to take responsibility.

PP-3 | FINANCIAL PLANNING

INTENT

Ensure that the funds to build the project are raised, managed and spent wisely, and that the long term funding for maintenance and upkeep is considered before building starts.

STRATEGIES

- Use transparency to increase trust. (Trust in the committee's leaders is an essential component for success.)
- Write down and share the fundraising plan.
- Make regular reports on your financial status.
- Contact playground manufacturers regarding the size you are hoping to create. Ask about their annual maintenance costs.
- Create a financial plan for your project that makes those purchase dollars and long term maintenance funds available when they will be needed.

RAISING FUNDS

Top Five Strategies by KaBOOM! Community Partners.

These represent the most successful playground build fundraising methods used by KaBOOM! and their community partners.

1. Buy a Piece of the Playground

This is a tried-and-true fundraising winner that can be customized for your playground project. Why is this so popular? You provide donors with a real sense of ownership and psychological connections to your playground.

- Break down your playground design. What are the most sellable pieces? Usually, it's a big colorful tube slide or the classic favorite, a swing set. Assign the highest prices for these pieces.
- Don't be concerned about getting the actual price for your piece. You know your community and your potential donors, so price pieces of the playground according to what you think is acceptable, achievable and profitable.

- A good visual display is important for this. Make a GIANT poster of your playground and clearly identify the pieces of the playground to be sold. Consider making brochures with individual photos of the pieces for sale. Include a little information about the piece: color, use, developmental benefits.
- Recognition is important. These types of donors may want the world to know that they “bought” a certain piece of equipment. Publish donor names and the pieces they purchased in a newsletter, or have them inscribed on a plaque at the playground.
- This is a great way to get people on board for the life of your playground. Send out annual thank-you notes and reports on the progress of your playground.

2. Challenge Grants

Build momentum through challenges! Challenge, or matching, grants are special grants that are awarded to a project once a set fundraising goal has been met. For example, an individual might say, “If your organization raises \$5,000 for the playground, then I’ll match it with another \$5,000.”

Or, a company might agree to something like this arrangement: “For every dollar raised, we’ll contribute two dollars.”

- Give yourself a specific timeframe in which to raise the money. This will help you to stay motivated and on target.
- Agree on a dollar-to-dollar, fixed amount before starting.
- Use challenge grants to leverage and motivate other donors. If they know that Company ABC or Foundation XYZ is backing your project with a challenge grant, they will be more likely to give.
- Don’t be afraid to go out and create your own challenge. These kinds of grants frequently don’t already exist, but may require that you persuade a funder to accept your own challenge!
- Keep your community abreast of your status by displaying a large “thermometer” showing how much you’ve raised or some kind of clock that displays how much time is left. The challenge alone should keep your volunteers motivated to continue fundraising, but this added visual tool has broader impact that can come as a result of visible reminders of your progress.

3. House Parties

Depending on the number of guests and the amount donated, you can almost guarantee that a party of 10 will generate at least \$100. Increase the number of guests, hold a party a week for awhile, and BINGO! — you can raise a considerable amount of money just by having fun.

- Identify a host who will pick a time, date, and style for the party. Supply a guest list if needed, but the real trick is to tap into all of your supporters’ different and diverse networks of family and friends.
- Generate invitations that announce the purpose of the party, the expected donation, as well as the usual logistics of time, place, directions, RSVP information, etc. Be sure to let people know they can make a contribution or send a check if they are unable to attend.
- Prepare a persuasive, simple, and short presentation on your project that includes photos, take-home brochures, etc. A good presentation will give people a clear and inspiring idea of your project. Don’t be shy about asking guests to consider giving an additional contribution after the presentation.
- Shop and prepare for your party. Remember that the host pays for the party — so plan a party that will fit your budget. A party doesn’t have to be fancy or be successful: a bagel brunch can be as good as a sit-down dinner.
- Host the party and have fun! Try to recruit future hosts at each party.



4. Spaghetti Dinners

Pasta is inexpensive and easy to cook for large numbers of people. Use this to your advantage and host a spaghetti dinner in your community. Add extra fun (like a silent auction) to increase your fund-raising potential!

- Decide on logistics — always with an eye and ear open as to what you can have donated. For example, ask your local community center or house of worship if you can use their meeting and eating space for free. Save time in the kitchen by asking a local restaurant to donate the entire meal — or at least part of it, like garlic bread, appetizers, or dessert.
- Create eye-catching (err on the simpler side) publicity materials such as invitations, fliers, menus, etc. that contain information about your project and how people can contribute if they are unable to attend.
- Try to combine the spaghetti dinner with an event that attracts a lot of people (after a big soccer tournament, in conjunction with parent/teacher night, etc.).
- Add some fun by asking local performers (singers, magicians, comedians) to perform for parents, children or both.

5. Buy a Brick Campaigns

People love the idea of having a lasting impact — and an engraved brick featured in an attractive brick walkway or wall is a great way for the general public to support your project. And, bricks can be a logical component of your park's amenities. So, through this fundraiser, you double your benefit — you raise money by selling a product you may actually need.

- Research brick companies that sell engraved bricks. Obviously you will want to base your decision on price, but also consider customer service, appearance of bricks, and any extras that may come with your purchase.
- Be sure to have a plan for how the bricks will be used, and show people what the grand plan (walkway, fence, etc.) will look like.
- Don't wait for the bricks to come in to recognize the donors. Make an indoor "yellow brick road" display using yellow index cards with each donor's name.
- This is a great way to encourage everyone to have a little piece of your playground. Most companies charge a net price for the bricks, and let you choose the sale price, depending on your needs and your community.
- Sell bricks to different donors at different prices: a price for alumni, a price for families, a price for corporations, etc. (Also applicable to campaigns in which people buy fence pickets.)

PP-4 | OUTREACH

INTENT

Ensure that stakeholders are recruited to the project, kept informed on project status, involved in the launch, kept informed about events at the play site, and be included in the community enough to offer their support when that becomes necessary.

STRATEGIES

- Hold public meetings.
- Nurture a community that will ensure that the project is given the time, attention and support it needs to succeed.
- Ensure that the stakeholders and surrounding community are aware of the changes as the project evolves through the iterations that will be necessary. It is extremely important to the project to retain their buy-in, since without that the viability of the project is at risk. Establish communication policies and systems to exchange high

quality and quantity information.

- Commit to communication with whatever means necessary.
- Develop a website, Facebook page or other on-line resource to share your updates.

PP-5 | EXPERTS

INTENT

People who have no previous experience in an area can achieve wonderful things. However, the selective use of experts can smooth the path, reduce the project timeline and increase project quality. For medium to large projects, the following professional specialties will be able to add value.

STRATEGIES

- Hire a landscape architect; they understand the relationship between design, construction, maintenance, regulations and the cost of outdoor play spaces. They can help you generate creative ideas with a technical understanding and serve as project managers, coordinate meetings, involve the appropriate stakeholders, understand most government regulation processes and even supervise construction activities. A landscape architect can offer guidance and support in a variety of ways throughout the life of your project. You can find an appropriate firm through the American Society of Landscape Architects at www.asla.org
- Hire an expert in the design of play environments for children with disabilities. Such a person is going to have knowledge about many different types of disabilities and how playgrounds can be designed to enrich play for many different children. This expert will most likely be well versed in accessibility standards and laws, as well as know of the latest research in playground design.

PP-6 | MISSION & VISION

INTENT

Projects drift away from their original objective for several reasons; loss of focus and long timelines are a couple of examples. The extent to which the committee's attention can be focused on the mission will determine the quality, cost-effectiveness, and timeliness of the outcome.

STRATEGIES

- Define Success. One of the priorities for the group guiding the process is to define what success means for your community. Does success mean that more children are using the playground? (Define 'more'.) Does success mean attracting more dollars spent by regional visitors to the town? Does success mean that specific children can now play outdoors? The answers to such questions will help when deciding between two alternative solutions and serve as a vision statement when introducing new people to the project.
- Write a Mission & Vision Statement. A mission statement answers the question 'Why does the organization exist?' It defines the fundamental purpose of the group or project. A vision statement answers the question 'What does it look like when we succeed?' A vision is a long-term view, describing how the organization would like the world to be once it has succeeded in its mission.

PP-7 | TIMELINE

INTENT

Establish a realistic timeline to avoid disillusionment and diminishing support.

STRATEGIES (IN APPROXIMATE SEQUENCE)

- Create a vision shared by leadership of the group
- Ensure all major shareholders agree with the vision



- Use the vision to identify all the phases of the project and associated timeframes
- Determine how long it will take to raise the funds needed to accomplish all phases of the plan.
- Check on how long it will take to obtain approval
- Consider breaking the project into phases if the timeline is too daunting.

PP-8 | SITE SELECTION

SELECTING A SITE

At this point, you probably have a site in mind for your future playground and play environment. If so, great! If not, use the following questions to navigate your way to finding the ideal site. Even if you do have a site in mind, the questions will help you evaluate its potential. Since the location of your playground will affect the playground's design, it is worth analyzing your site carefully at the beginning to minimize prep costs and maximize safety and use for years to come.

KaBOOM! suggests you consider the following questions:

Who owns the land?

This is not always as obvious as you might think. Check into the ownership, because the owner of the land ultimately will be liable for the playground and the children who play on it. If neither you nor your organization own the land, we encourage you to contact the landowner and request proof of land ownership and general liability.

How big is the site?

Some equipment, like swings, requires lots of extra space for fall zones, so measure as large an area as you can for planning purposes. Of course, the larger the area, the more expensive it will be to surface it properly.

Is the site ready?

The site should be as level as possible, although a very slight grade (1%) can improve drainage. Drainage can also be assisted by placing geotextile fabric beneath loose fill surfacing. If the site needs to be excavated and/or leveled, expect expenses for machinery and labor. Do not let a major slope on the site intimidate you. A creative landscape architect or playground designer may be able to work the natural slope into the playground design.

What man-made elements are on the site now?

If you have an existing playground, a professional can help you assess its safety so that you can decide whether to remove it (at a cost), or not (leaving possible safety hazard in your community). Are there buried utilities, sewage pipes or sprinkler pipes? These and other "hidden" elements can present hazardous situations during installation.

Your local phone/utility company will usually do a free check for underground utilities upon request. You'll have to consult the original plans, or the landscaping company who installed it to see if a sprinkler system is in place. Don't just concentrate on what's below the surface, keep in mind any overhead utilities as well.

What natural elements are on the site?

Existing trees and shrubs may contribute shade and beauty to a new playground, but their location (and/or their underground roots) might get in the way. Any overhanging branches should be trimmed and kept at least seven feet from play equipment at all times. Consider kinds of trees; those that are fruit-bearing or thorny should not be located near the playground. Fruit-bearing trees, for example, drop fruit that increases maintenance and cleaning.

Ponds, streams, and drainage ditches can present hazards to children, and signage cannot be relied to deter young children who cannot read. If your potential site is near a larger body of water, such as a river or lake, you may want to obtain a flood plain map from the Federal Emergency Management Agency (FEMA) to make sure that the site is not located in a flood plain.

Finally, consider the sun! The surface of some play equipment (slides and decks) can absorb heat and become hot. Equipment should be placed away from the sun, facing north or east when possible.

What's the space being used for now and what has it been used for in the past?

Is it already a place that the community is aware of and uses? What has it been used for in the past? Do your archeological duties and find out what the land has been used for over the past one hundred years, because you may incur a huge, unwanted, and surprise cost as you begin digging!

Where is the site in relation to possible obstacles or hazards?

The site of the playground should be visible, and ideally, not hidden behind a building. This helps with supervision of children and can cut down on vandalism. A playground should also be a safe distance from any roads or otherwise congested areas.

What amenities are available to the site? Is security lighting available? How about parking, water fountains and restrooms?

Take the time to answer these questions before you begin! This way, you will prevent "surprises" that could stop the entire project, and knowing answers to these questions will give you credibility later on.

PREPARING YOUR SITE

Looking at one of the huge, modular play units that have become the standard for new playgrounds, you may think you have to be a rocket scientist to design, plan and construct one (or at least an architect or an early childhood specialist). You don't! Being a parent, a member of a community-based organization, a business person, a teacher or anyone with an interest in the well-being of children means you probably know kids, and that goes a long way in designing and planning a great play environment.

Two items that will affect your design from the outset, though, are the playground site and your budget. The site's size, existing features (both natural and man-made) and slope are all factors that influence your design. The size of your budget and the amount of money your community will be able to raise for the project will define what you can build. Playgrounds and play environments come in all shapes and sizes, so one can definitely be designed to fit your community's needs.

PP-8 | SITE PREPARATION

SITE PREPARATION TIPS FROM KABOOM!

Site Leveling

It is best to choose a relatively flat surface for your new playground. If such a site is unavailable, you will have to level off the site. If there is an obvious slope, machinery may be required to level it. If the bumps are slight, a good crew of volunteers can level the site with some old-fashioned sweat and elbow grease. Alternatively, a playground designer or landscape architect can help you to decide if bringing in backfill is a better option for leveling.

Tearing Up Old Asphalt/Concrete

If you plan to build your playground on an existing asphalt or concrete surface (such as a parking lot), consider removing the asphalt/concrete in the area of your playground - depending on the equipment and surfacing you choose. Consult with a play equipment company representative or landscape architect to determine whether this surface needs to be removed. This work is usually done by professionals who have the proper tools and machinery at hand.

Digging Holes

Whether you are building on a grass or dirt surface, or even an asphalt or concrete surface, you will need to dig large holes for the play equipment. The footers that support the equipment are inserted into these holes, which are then filled with concrete. Although a group of volunteers may be able to accomplish hole-digging on your build day, it is always a good idea to dig the holes several days before. We recommend this to eliminate a large group of volunteers around potentially dangerous machinery in case something goes wrong. Holes can be dug in several ways. The chosen method may be determined by the financial and human resources at hand (consider donated resources).



Old Play Equipment Removal

Many people are interested in a new playground because their existing one may be old and/or unsafe. In these cases, the first step is to evaluate existing equipment. KaBOOM! recommends that you ask a play equipment company representative or a National Playground Safety Institute Certified Inspector to do a safety check. They should determine if the equipment complies with CPSC and ASTM requirements. Be wary of thinking that you can modify or repair older equipment. Modifications have to be approved by the manufacturer in writing to maintain product warranties.

Concrete Slabs

A concrete slab is usually required if you have chosen a synthetic surfacing material and are not already building on cement or asphalt. Laying a slab may involve specialized labor and tools, so work with someone who knows. You need to allow an appropriate amount of time for the concrete to set-up and take hold (depending on the type of concrete and weather). So, this needs to be arranged and planned for well before build day. It is worth checking city codes before you arrange for the work to be done.

POST HOLE DIGGING

Human Labor

This is very long and tiring work, and is not recommended. (Requires tools such as post-hole diggers, shovels, digging bars, etc.)

A hand-held power auger

This kind of machine usually requires two fairly strong people to operate and is basically like a large drill bit that spirals itself into the ground. Power augers can usually be rented at a tool rental company. They do not work well on rocky or hard soil, or with concrete.

A Bobcat with an auger bit attachment

A Bobcat requires an experienced operator, and the right size auger bit must be begged, borrowed or rented.

Utility Auger

A utility auger is a specialized piece of machinery that is used by professionals, such as a power company. It requires skilled handlers. Cities on occasion donate this service.



LAYOUT



LAYOUT (LA)

Definition: the placement and relationship of events on the playground and the surrounding environment in order to maximize inclusion.

INTENT:

Provide everyone of all abilities inclusive access and the opportunity to move throughout the play space safely and independently.

LAYOUT CONTENTS	PAGE
LA-1 General Layout.....	19
LA-2 Entry and Orientation	19
LA-3 Wayfinding	20
LA-4 Perimeter Containment	20
LA-5 Orientation Path.....	21
LA-6 Pods, Rooms, and Zones	22
LA-7 Color as a Safety and Wayfinding Tool.....	22
LA-8 Gathering Spaces.....	22
LA-9 Line of Sight.....	23
LA-10 Landscaping	23

LA-1 | GENERAL LAYOUT

INTENT

Design the experience in a way that maximizes everyone's enjoyment of the facility; to ensure safety and independent use, and to encourage play between people of different abilities, ages, cultures, and genders.

STRATEGIES

- Choose the unitary surfacing that best meets the needs of the users of the playground (See AC-1)
- Create an entry experience for the playspace (See LA-3) Place the entry way in order for users and caregivers to move directly on to the orientation path.
- Develop a wayfinding system to help people find their way through the play space (See LA-3)
- Install perimeter containment (See LA-4)
- Arrange play events as a series of rooms, zones or pods around the path. (See LA-6)
- Place equipment and plants so that they can be easily reached by children of different heights. (AC-2)
- Intersperse gathering spaces and quiet area with the play events. (See LA-8 And PR-14)
- If using a modular play system, place it in the back or corner of the play space. This minimizes the amount of the play space where a child cannot be seen. (See LA-9)
- Create an orientation path (See LA-5)
- Provide extra space throughout the playground. There are many children who require this extra space to maneuver around play events. Children who are using a mobility device need extra space to make turns easily and wheel themselves into proper positions for transfers on to the play event. The extra space will also accommodate the larger bodies of an adult who maybe assisting a child. Children who are visually impaired use the extra space to ensure that they play independently without entering a fall zone. The extra space also supports children with poor balance, tactile sensitivity, or who have trouble understanding where their bodies are in space.
- Hire a landscape architect to help meet the intents.

LA-2 | ENTRY WAY & ORIENTATION

INTENT

Allow people to orient themselves to the playground without being thrust into the excitement of the activities and stimuli. This will be particularly important in the case of a child or caregiver on the Autism spectrum.

This area at the entrance to the playground space should familiarize individuals with play space layout, features, and activities before they arrive in the play space. This will minimize surprises. For some users surprises lead to crises and/or provide on-site signage or web-based information that familiarizes individuals with play space layout.

STRATEGIES

- As in the foyer of a home or office, this is a space that allows people to acclimatize to the environment, before they are engaged in the activities of the residents or business on the premises. This is a good place to welcome people, thank sponsors, set expectations and point out emergency procedures.
- There should be a low level of visual and auditory stimuli.
- The soothing and orientation effects of landscaping can be used here to good effect.
- There should be a clear line of sight from the entry way into the play space and parking lot so a caregiver can quickly identify where a child goes, if they do not stop in the entry way.

- For larger play spaces, provide signage with a plan view of the area and a site map defining individual site features and activities.
- The signage should be located along the entry path and visible prior to entry into the play space itself.
- Include seating. Consider including a bike rack.

LA-3 | WAYFINDING

INTENT

Allow each person to maneuver their way around and through the play space regardless of their cognitive or sensory capabilities.

Create multi-sensory signals and cues in the play space and surrounding environment. This will help children with differing cognitive and sensory systems to be guided through the play space by sight, sound, touch, and body spatial awareness.

Wayfinding:

According to the IDEA Center at the University of Buffalo, "Wayfinding is the organization and communication of our dynamic relationship to space and the environment. Successful design to promote wayfinding allows people to: (1) determine their location within a setting, (2) determine their destination, and (3) develop a plan that will take them from their location to their destination. The design of wayfinding systems should include: (1) identifying and marking spaces, (2) grouping spaces, and (3) linking and organizing spaces through both architectural and graphic means."

STRATEGIES

- Provide a tactile map of the area. This could be the same map that is provided for everyone. A tactile map is a raised schematic map showing what will be encountered throughout the playground. Tactile maps are widely used as a way-finding mechanism for people with visual impairments, but can also be helpful for people who do not know how to read. There are large maps that are placed in an entrance area. There are also portable maps. (See resources for additional information)
- Use signage to direct people to specific places in the play space such as water fountains or restrooms. Use large letters with contrasting colors as well as picture or universal (non-reader) symbols on the signage. The signage can also have raised letters or braille on them to assist people with visual impairments.
- Use a hierarchy of paths using different but consistent materials to help children to orient around a space. Consider texture codes or colored patterns on paths which are consistent across the site to give meaning and pleasure.
- Use appropriate landscaping features (shrubs, long grass, rocks) that offer a texture, smell, color unique to each area and can guide the child around the play space, allowing for sensory interaction and opportunities to explore.
- Use audible orientation clues to help children and parents with vision disabilities, as those with other disabilities. If the playground is large, consider creating a signature sound for each of the different zones of the play space.
- Mow pathways across lawns to assist children to find their way around an otherwise featureless area of grass.
- Place tactile indicators at entries to help children find where they would like to play.
- Place audible communication for children who are hard of hearing in quieter places on the playground.
- Use of a limited amount of scented plants to help distinguish between spaces, and assist with orientation.
- Use different colors of surfacing to depict quiet or busy areas or put one color around the equipment to show where the use zone is and another color throughout the rest of the playground.

LA-4 | PERIMETER CONTAINMENT

INTENT

Allow children to play freely without the risk that they run into nearby dangers, such as traffic. This becomes particularly important in the case of children on the Autism spectrum who run away from stimulation where in

many cases the caregiver has little hope of reaching them. Fences have a calming effect for children on the Autism spectrum as large spaces often say 'run' to them. Teach children to understand boundaries.

STRATEGIES

Perimeter

- Create a perimeter boundary around the entire play space with only one or two entrances. Some of the ways to create perimeters are by using walls, fences, landscaping or topography. Do not use water as part of the perimeter (although water is encouraged in the play area).
- Provide double-width gates for maintenance access.
- Avoid horizontal components that can be climbed upon or create entrapment spaces.
- Use materials and colors that can be easily seen at night and by people with visual impairments. Cables or wires are not good choices.
- Provide seats near fence openings to make supervision easier for adults (See SU- 1)
- Consider designs that make the fence a playful feature of the space.
- Have a few clearly identifiable openings. The location and direction of the orientation path will help identify these openings. The caregiver and a helper can go to those points and watch for their child, knowing they are somewhere in the play space.

Gates

- Some inclusive playgrounds choose to put in gates at all the entry ways to ensure completion of the perimeter. The gates need to be designed so as to be inoperable by a child, but can still be operated by an adult using a mobility device. This ensures that a child cannot leave without adult help.

LA-5 | ORIENTATION PATH

INTENT

Allow users to survey the play experiences prior to engaging. Allow users to assess the amount of physical and social contact they can reasonably expect. Provide direction to users through the play space. Children on the Autism spectrum or who have Sensory Processing Disorder (SPD) will benefit from a spatial arrangement that allows children to move to a safe zone, the orientation path, if their anxiety rises. They will still be able see the activity which may increase their confidence to re-enter the play area.

STRATEGIES

- As a significant component of the wayfinding scheme, an orientation path that surrounds the play area allows users to survey the different activities without engaging in them. The orientation path lets a child to decide whether to participate or not.
- The path should be a firm, accessible, even, and predictable surface using materials such as asphalt, concrete or pavers. Playground surfacing material such as Poured in Place could be used to create the path.
- Place the path in one of two ways:
 - a) Surround the play equipment.
 - b) As a central spine from which the pods or zones (LA-6) originate.

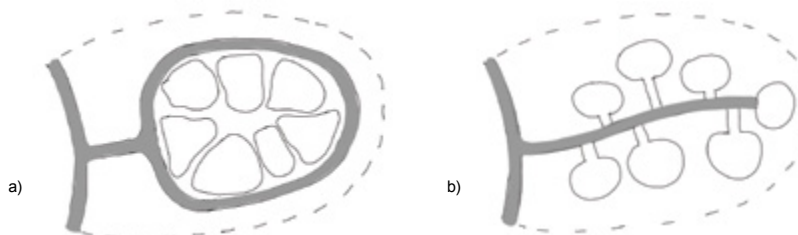

- Make the path wide enough (72" is recommended) so that two people using mobility devices can easily pass one another.
- It should be free of barriers with clear line of sight along the path.
- The construction of the path should be consistent (same colors, textures and cues). Predictability is the key.
- There should not be any play activities on the orientation path.
- Delineate where the path ends and the play area begins by providing a visual or tactile cue (e.g. place a bright yellow strip at the edges or change the texture at the edges of the path).

LA-6 | PODS, ROOMS, AND ZONES

INTENT

Divide the larger playground into areas that allow for delineation of activities. Example: separate vigorous play from quiet play areas.

Many of the goals discussed in Play Richness are best achieved through clearly identified play pods.

STRATEGIES

- Locate distinct play pods directly off the orientation path.
- The pods can be defined through a path, surfacing, seating, landscaping, or the equipment itself.
- Determine the number of pods and their relative size by dividing the desired activities and equipment into the categories discussed in Play Richness.
- No single pod should dominate the design.

LA-7 | COLOR AS A SAFETY AND WAYFINDING TOOL

INTENT

Color can be an important tool in communication as applied to wayfinding and safety.

STRATEGIES

- Use high contrast colors between the equipment and orientation path.
- Modular systems: Changes of height can be difficult to see. Perception of those changes can be accentuated by changing the deck color at each height change.
- Surfacing: Use two different colors of surfacing material; one color within the fall zones and one color outside the fall zone. This will help a child to determine where the danger to them may be greatest. Dark colors, when used on the ground surface, may be perceived as holes in the ground.
- Include the meaning of the color scheme in the wayfinding tools. Never use just color in wayfinding, as someone who is color blind may not be able to distinguish the difference between colors.
- To help people who have trouble distinguishing between colors (10% of males are color blind), choose colors that contrast light colors (blue-green green, yellow and orange) with dark colors (blue, purple, and red). Do not use orange and red or blue and green as contrasting colors. Choose combinations such as yellow/violet, green/purple, orange/blue, red/blue-green.

LA-8 | GATHERING SPACES

INTENT

Allow the community to use the playground as a meeting point. This builds community spirit and reinforces the role of the playground as a community resource.

Using the play space as a community resource and gathering place increases support for the facility, increasing the potential for fundraising and resistance to budget cuts that may target resources not seen as widely endorsed.

STRATEGIES

- Incorporate gazebos and pavilions in places where parents can see their children but can socialize with their peers.
- Use seating, grouping of play equipment (e.g. boulders), or other landscaping techniques to create gathering places throughout the play space.
- Shade these gathering places to increase the chances of extended use in hot weather.
- Incorporate site amenities such as seating, water fountains and trash cans in order to increase the likelihood of people gathering. (See Support Features section.)

LA-9 | LINE OF SIGHT

INTENT

Maximize parental supervision of the children using the playground. This is particularly important when children who have a tendency to become over-stimulated run from the source of the stimulation and possibly away from the caregiver. It is also important when a caregiver is responsible for multiple children of different ages.

A caregiver needs to be able to stand at almost all points on the playground orientation path and be able to tell if there is a child using almost all the play events on the site. If there are many play zones within the playground, the line of sight should at least cross each play pod or zone (see LA-6) allowing a caregiver to find their child easily within their pod.

STRATEGIES

- Maximize the use of “see through equipment” so that children are visible (eg rope structures) and minimize the use of large equipment that does not have holes through which a child is visible on the other side.
- Place modular systems toward the rear of the playspace.
- Line of sight is significantly improved if the space is broken into pods that can be supervised individually.
- Place seating at multiple points around the entire area and at each entrance and exit.
- Emphasize freestanding independent items over consolidated modular structures. These do not inherently guarantee visibility, but are usually less opaque than a modular structure.
- Lay out the events in such a way as to maximize visibility across the structures and spaces.
- Enable the caregiver to view both the exit and entrance to the play area or in larger playgrounds at least the section in which they are playing.
- Avoid using high walls or dense, tall planting to delineate the play pods.

LA-10 | LANDSCAPING

INTENT

Use plantings to soften the look and feel of the playground, help define the pods, zones or rooms where the play equipment is located, and to create shade.

STRATEGIES

- Use a landscape architect with experience in inclusive play environments to develop a complete design for the space.
- Try to see what the space will look like when it is planted, ten years afterward and all the time in between. At any



time in this growth cycle, the landscaping should not block routes or impede people with disabilities.

- Make sure that the landscaping materials do not include poisonous materials that children could put in their mouths. While the landscaping plan should include a variety of textures, do not use any material that has thorns or any other texture that might hurt someone running into it. Avoid plants that pose a choke hazard (e.g. berries). Avoid bee attracting plants (e.g. lavender).
- See PR-13 for information on interacting with natural features.



inclusive play
design guide

ACCESS



ACCESS (AC)

Definition: The design of the play space and surrounding environment as it relates to the users and caregivers getting into, around, and out of the play area.

INTENT:

Provide all people of all abilities inclusive access and the opportunity to move throughout the play space safely and independently.

ACCESS	PAGE
AC-1 Unitary Surfacing	27
AC-2 Reach Ranges.....	27
AC-3 Transfer Platforms	28
AC-4 Transfer Steps	29
AC-5 Width of Route	29
AC-6 Flush Transitions (Surfacing)	29

AC-1 | UNITARY SURFACING

INTENT

The impact attenuation surface is the safety surfacing that surrounds the playground equipment. Although the ADA law allows loose fill such as engineered wood fiber or rubber pieces to be used in an ADA compliant playground, loose fill has disadvantages from an inclusive point of view

- (1) It is almost always difficult to move a mobility device across this type of material.
- (2) When not maintained it can eliminate smooth transition from one type of surfacing to another.
- (3) Parents raising children on the Autism Spectrum report that their children will often pick up this material and mouth it.

For these reasons unitary surfacing is highly recommended for inclusive playgrounds.

STRATEGIES

Pour-in-place, tiles, playground turf, and some hybrid surfacing are considered unitary surfacing for the purpose of this guide.

In order to ensure that your playground has the best surfacing for your site and climate, it is recommended that the playground planning committee:

- Visit various playgrounds in your area with different surfaces. Ask the owners of the playgrounds how the surfacing has worked and how much maintenance has had to be done.
- Meet with multiple vendors of different type of surfacing. Ask them about warranties and expected life of the surfacing. Ask who does the installation; whether they are certified by the manufacturer, and how much experience they have with this product.
- Check that the surfacing has IPEMA (International Playground Equipment Manufacturers Association) Certification by visiting www.ipema.org

See playground surfacing FAQ in this guide.

AC-2 | REACH RANGES

INTENT

Being able to reach and touch play events and landscaping is critical to a child's engagement. Research has demonstrated that it is not enough for a child to see, they must also be able to touch in order to be engaged. All children should be able to interact with the play events, wayfinding signage and surrounding tactile input, with their hands.

Since most children need to touch the object they are interacting with, a child's functional ability will be more of a determinant than their age of what they can touch and manipulate in the play environment. This means that include everyone means placing an object in the reach ranges of all children, not just the typically developing child.

STRATEGIES

- Place play panels, landscaping, telescopes, water tables, sand tables, etc. at varying heights to accommodate children at different heights and who may have different abilities to reach.
- Include multiple pieces of the same equipment at different heights, for example on a deck put in two telescopes at different heights.
- Ensure that there is a child who is using a wheelchair can access the play events by rolling under them as reaching forward is more enjoyable and doable than reaching to the side to play.

The Gross Motor Function Classification System (GMFCS) is used to generate standards for accessibility measurements. The recommended ranges below are based on the functional ability of the child of a certain age range and the middle of the GMFCS range of capability levels.



6 year old – Level III:

Assumption: 6 years of age and in the 50th percentile for height and weight. Children sit on a regular chair but may require pelvic or trunk support to maximize hand function. Children move in and out of their chair sitting using a stable surface to push on or pull up with their arms. Children walk with a hand-held mobility device on level surfaces and climb stairs with assistance from an adult. Children frequently are transported when traveling for long distances or outdoors on uneven terrain.

10 year old – Level III:

Assumption: Children walk using a hand-held mobility device in most indoor settings. When seated, children may require a seat belt for pelvic alignment and balance. Sit-to-stand and floor-to-stand transfers require physical assistance of a person or support surface. When traveling long distances, children use some form of wheeled mobility. Children may walk up and down stairs holding onto a railing with supervision or physical assistance. Limitations in walking may necessitate adaptations to enable participation in physical activities and sports including self-propelling a manual wheelchair or powered mobility.

Assumptions and appropriate reach ranges

	6 yr old	10 yr old
Upper reach range	38.3"	43.5"
Lower reach range	19.4"	21.1"

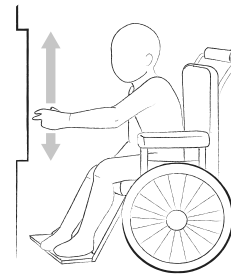

AC-3 | AC-3 | TRANSFER PLATFORMS

INTENT

Allow a person who is using a mobility device to transfer into and out of that device independently.

A child who is unable to use their legs proficiently may be able to move themselves around the playground if transfers in and out of the chair can be made easily.

STRATEGIES

After getting measurements for over 40 pediatric wheelchairs, the authors of the guide determined that the best height for a transfer platform should be 16-18". This is a portion of the range allowed by ADA and aimed at maximizing ease of transfer.

- Consider all the surfaces adjacent to the accessible route. Estimate the possibility of a playground user transferring to them from a chair.
- Look at how a child who is using a chair might transfer to the events that don't have a platform per se. Is there a surface or grip point that can help this child be included?
- When considering the space a child will need when sitting: A 6 yr. old will occupy 3'-2" sitting with their legs out in front of them. A 10 yr. old will need 3'-8".
- Provide on-deck transfers that facilitate movement from a mobility device onto the play activity. This is especially important at slides.

Consider a deck with a transfer platform on one side and a set of steps of the other side to facilitate children of different abilities being able to enter the play system.

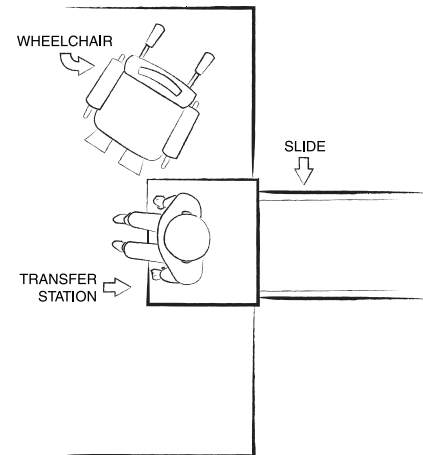

AC-4 | TRANSFER STEPS

INTENT

Allow someone who does not have use of their legs to be able to move their body between elevation changes on the play equipment and back into a mobility device.

STRATEGIES

- If someone is moving themselves on their backside, the smaller the change in height between elevation between decks or play surfaces, the better. For this reason, the following step heights are recommended in order of preference.
 - a) 4"
 - b) 6"
 - c) 8"
- Talk to playground manufacturer representatives about their ability to ramp the elevation change or break down the height change into manageable increments.

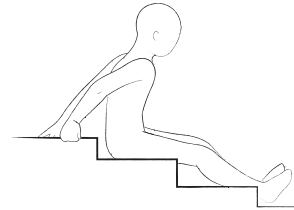

AC-5 | WIDTH OF ROUTES

INTENT

Build accessible routes throughout the play space. On those routes allow wheelchair users, parent with strollers, and/or children who do not like to be touched, enough room to pass each other while using the play space. The playground can help children grow beyond their limitations, so a mixture of passage widths within the playspace will provide choice and play richness.

STRATEGIES

- Consider the play environment as a small city. Which routes need to be arteries that connect one side of the city to another? Which ones have less priority? Which areas are the equivalent of sleepy, quiet neighborhoods where a highway would destroy the intent?
- Entry and exit onto all accessible routes must be 60" (US ADA law). A 72" width allows two wheelchairs to pass each other and is therefore a recommended step beyond ADA.
- The available room in front of play components should optimally allow a person in a wheelchair and their ambulatory companion to play adjacent to one another.

Note: Review the ADA sections that discuss accessible routes: Chapter 4 - Outside the play space Chapter 10 - Section 1008.2 – Within the play space

AC-6 | FLUSH TRANSITIONS (SURFACING)

INTENT

Allow people using mobility devices to move freely by providing flush transitions to all areas of the play space and surrounding area.

STRATEGIES

- Transitions must be flush between all route surfaces and play surface access points.
- Play surface connections must have tight seams throughout the play space. There should be no barriers or trip hazards between sections of play space that would impede a user of a mobility device.
- To ensure this occurs:
 - Perform an accurate topographic survey.
 - Write the requirements in the bid/contract documents.



- Hold contractor accountable by monitoring execution.
- Transitions between surfaces often indicate the end of one contractor's work and the beginning of the work of another. The quality of the communication between contractors will be a major determinant in the quality of the transition.



inclusive play
design guide

PLAY RICHNESS



PLAY RICHNESS (PR)

DEFINITION:

The quantity, quality, diversity and inter-relationships of play events on the playground.

INTENT:

Provide a rich, inclusive play space where children of all abilities can grow and learn through physical, emotional, sensory, and social experiences.

Play Richness is divided into three categories: Physical, Social, and Cooperative Play. When selecting play equipment and activities, the goal is to include strategies from each of the three play categories. Each type of play is crucial to a child’s development. Having a mixture of the categories will increase the probability of creating an exciting and more inclusive playground.

SELECTING EXPERIENCES:

Physical: Choose which physical play experiences you want on the playground, for example: rocking and sliding. Choose 2-3 pieces of equipment/activities within each play experience.

Note: Challenge levels have been added to the Climbing, Crawling & Strengthening section to help select a variety of experiences in this category.

Sensory: Choose a wide variety and depth of sensory experiences.

Social: Social play is a critical to the success of a playground. For some children socialization comes easily, for others, especially some children with disabilities, it does not. Therefore it is crucial to design spaces with specific activities and equipment that encourage children to play with one another.

PHYSICAL	PAGE
PR-1 Spinning	33
PR-2 Sliding	33
PR-3 Rocking	33
PR-4 Swinging	34
PR-5 Climbing, Crawling & Strengthening	34
PR-6 Balancing	35
PR-7 Jumping and Bouncing.....	36
PR-8 Walking, Running and Rolling	36
PR-9 Movement Experienced From a Wheelchair.....	36
 SENSORY	
PR-10 Tactile	37
PR-11 Auditory	37
PR-12 Visual	38
PR-13 Interaction with Natural Features	38
PR-14 Cozy Places.....	39
 SOCIAL	
PR-15 Cooperative Play	39
PR-16 Social Interaction	39
PR-17 Dramatic & Imaginative Play.....	39
PR-18 Loose Parts.....	40

PHYSICAL

PR-1 | SPINNING

INTENT

Challenge, stimulate, and develop the user's vestibular system by providing activities which turn their body in a rotary motion. When children spin, different parts of the brain are stimulated simultaneously. This builds new and more developed pathways throughout the brain – pathways that improve learning potential, spatial awareness, rhythm and more. Spinning activities develop the brain in such a way that pre-reading concepts are advanced while improving balance, muscle control and gross motor skills.

STRATEGIES

- Choose different pieces of equipment to provide children the ability to sit and spin, stand and spin, and lay and spin. This could mean three different pieces or one piece could provide the ability to play in different positions. For example: a child could sit, stand or lay on a tire swing.
- Provide challenge by choosing spinning equipment with and without hand holds.
- Choose spinning equipment where a child can support themselves by having multiple touch points. (See glossary for an explanation of multiple touch points)

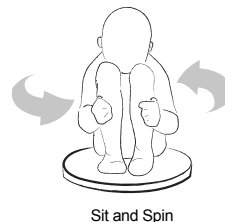

Sit and Spin

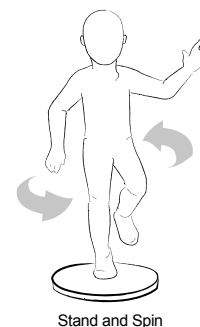

Stand and Spin

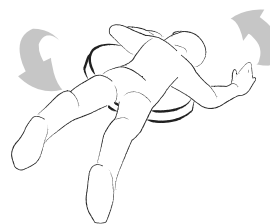

Lay and Spin

PR-2 | SLIDING

INTENT

Offer the experience of a modified fall through space and the thrill of perceived risk while stimulating the user's vestibular system and sense of balance.

STRATEGIES

- Provide slides at a variety of heights. For example: 2', 4', and 6'.
- Include at least one slide that carries two people side-by-side.
- Provide a wide slide so that a parent can support a child going down the slide.
- Choose different types of slides: Roller, tube, textured, curved, straight, hill, spiral, etc.
- Have one slide that does not create static electricity for people with a cochlear implant.
- Provide a place for the disabled person to sit while their chair is being retrieved. (See SE-3)
- The tallest slide should be accessible. (See SE-1)

PR-3 | ROCKING

INTENT

Challenge and develop the user's vestibular system by moving his/her body in a rocking motion.

STRATEGIES

- Include at least one piece of equipment that provides a to-and-fro motion and another one that provides side-to-side motion.



- Include multiple pieces of rocking equipment to support children in a variety of positions: sitting, standing, and lying. Certain pieces of equipment could provide multiple experiences. For example, a child could sit or lay on some kinds of spring rockers.
- Include at least one rocking piece of equipment intended for individual play and another intended for multiple children.
- Include backrest, footrests and hand support on the rockers.
- Include rockers with different width seats to accommodate a range of sizes.
- Include rockers with a longer & deeper seat to allow a child to sit in front of an adult.
- Provide adult-sized seats on a few pieces of equipment to allow older children and adults to use them.

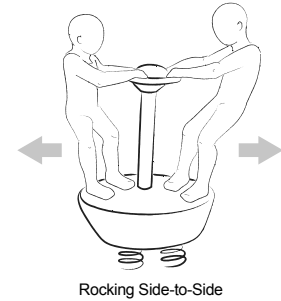
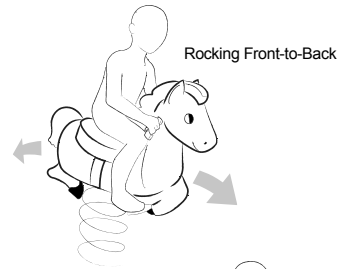

PR-4 | SWINGING

INTENT

Challenge, stimulate and develop the user's vestibular system by providing various swinging events.

STRATEGIES

- Provide a swing that moves in a linear motion and another swing that moves in a circular motion.
- Provide an adaptive swing with harness as well as other types of adaptive swings.
- Consider a variety of swings and swing sizes. E.g. a belt swing, toddler swing, tire swing, a bird nest swing
- Include a swing which provides a full body experience and physical support when a child lays on it. e.g. a bird nest swing

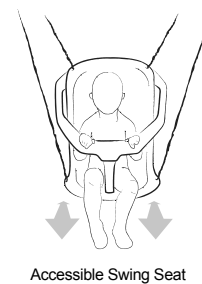
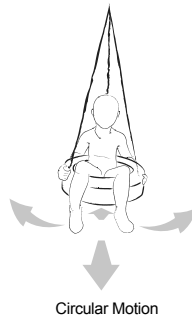

PR-5 | CLIMBING, CRAWLING & STRENGTHENING

Note: Challenge levels have been added to help select a variety of experiences in this category.

INTENT

1. Challenge, stimulate, and develop the user's proprioceptive system by providing activities that allow for the contraction and stretching of muscles as well as the bending, straightening, pulling and compression of the joints.
2. Improve motor skills such as power balance, coordination, strength, and dexterity.

STRATEGIES

Climbing

Provide at least two challenge levels for climbing. If climbing activities are selected, a Level I event must be included to include the users who have the least strength.

Level I: A combination of any of the following characteristics: low to the ground, low slope, hand holds on each side (hand holds should be big enough for a child to climb using the back of their arms), the ability to put the entire body on the climbing event to provide more support, the path a child takes from bottom to top (or across) the climber must be obvious. Example: level to the ground web net, a ladder with hand holds, a low boulder, stairs with hand holds.

Level II: A combination of any of the following characteristics: can be angled, there must be at least one way to support the body (put the full body on it, one hand hold), there can be multiple paths to reach the top, but they must be obvious, first step is easy to reach, the steps are evenly spaced. Example: Angled rock wall, medium size boulder with good hand or foot support, a straight up climber with even steps and good hand or foot supports, a curved climber with even steps where the entire body can be on it for support.

Level III: A combination of any of the following characteristics: reaches a high place, is vertical, can have a complicated or multi-way path to reach the top, supports are minimal or not obvious, is dynamic, requires great agility to accomplish. Level III climbers are ones normally used for the oldest children Example: large boulder with limited supports, web net, vertical rock wall.

Crawling

Provide at least two (2) activities that allow a child to attempt different challenge levels.

Level I: A short tunnel placed on the ground.

Level II: A longer tunnel on the ground, or elevated with accessible routes on either side.

Level III: A tunnel that changes elevations.

Arm Strengthening

Provide at least two challenge levels of overhead events or other arm strengthening equipment. If an overhead event is included on the playground, a Level I event must be included.

Level I: An arm strengthening activity that is at ground level and can be used by a person in a wheelchair. Examples: An accessible sand digger. A chinning bar or overhead event appropriately positioned.

Level II: A static overhead event where the rungs are close together, entry on to the equipment is simple, and an obvious path exists to follow from beginning to end.

Level III: A very challenging overhead event which may include all or some of these characteristics: high off the ground, require long reaches, it moves, and the path from the beginning to end can be modified requiring higher levels of motor planning.

PR-6 | BALANCING

INTENT

Provide a wide variety of activities that increase a user's ability to balance on their feet (dynamic balance), and build core body strength.

STRATEGIES

- Provide one balancing activity where a child can use one hand to help support their body as well as another balancing activity where the child can use both hands.
- Provide at least one balancing activity for each of the following positions: sitting and standing. One piece of equipment could meet both criteria. Example: a stool could be sat or stood on.
- Provide a piece of balancing equipment that is static and another one that is dynamic.

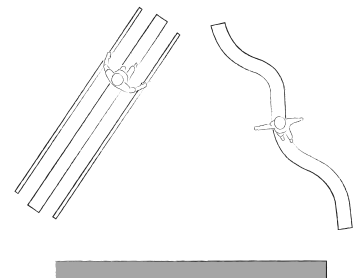



- Incorporate challenge by choosing balancing activities of varying widths. Add further challenge by having some of the standing balancing activities straight, while others are curved.
- Provide a balancing activity at ground level and one balancing activity that is elevated and reached by an accessible route.
- Ground level activities could be patterns in the surfacing.

PR-7 | JUMPING AND BOUNCING

INTENT

Challenge, stimulate, and develop the user's vestibular system and proprioceptive system by jumping or bouncing activity.

STRATEGIES

Provide at least one jumping or bouncing activity that is used while sitting as well as another activity that is used while standing. This could be the same piece of equipment.

PR-8 | WALKING, RUNNING AND ROLLING

INTENT

Provide opportunities for people to move through space using their typical mode of mobility in order to build endurance, increase muscle tone, and master dynamic balance.

STRATEGIES

Include space and equipment for games to be played (i.e. basketball, tether-ball, tag).

Include a bike trail and/or trike trail that can be accessed from the perimeter path.

Create a track using a design in the surfacing.

Include a maze or running obstacle course. Ensure the route is wide enough for a wheelchair to easily maneuver through the space.

Build a path that rise and falls along its length to allow runners (feet) and rollers (wheelchairs) to build strength with the resistance of their own body weight.

PR-9 | MOVEMENT EXPERIENCED FROM A MOBILITY DEVICE

INTENT

Enable an individual using a wheelchair to experience a motion that stimulates their vestibular system without leaving their chair.

STRATEGIES

Provide a piece of equipment that moves the child and their wheelchair. The piece of equipment should be a social experience i.e. more than one person can play on it at a time. Example: gliders, merry-go-rounds, and carousels designed to meet this intent.

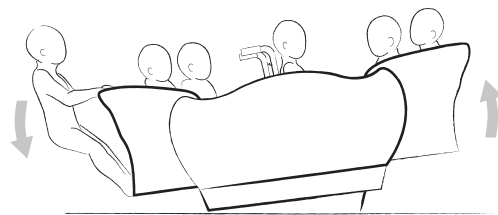

SENSORY

PR-10 | TACTILE EXPERIENCES

INTENT

Provide activities in the play space that exercise and develop the user's sense of touch.

STRATEGIES

- Provide the opportunity for a child to feel at least one of each of the following textures.
 1. Smooth — The material is free from projections or unevenness of surface. Example: a metal pole, metal slide, mirrors, marbles
 2. Soft — The material is yielding readily to touch or pressure. Example: grass, rubber components of rope climbers.
 3. Hard — The material is solid and firm to the touch; unyielding to pressure and impenetrable. Example: rocks, plastic play equipment
 4. Rough — The material is coarse. It has projections, irregularities, or breaks. Example: boulders or rocks, rope.
 5. Grainy — The material has a granular texture. Example: sand, dirt, rocks or boulders (natural or concrete).
 6. Uneven — Bumpy, not level or flat. Example: a slide that has bumps built in, plastic decoration that sticks out from the base of a piece of equipment.
- Provide one opportunity for a child to have his full body involved in the activity. Example: roll down a hill, put sand all over themselves, use a roller slide, water play where the entire body gets wet.
- Provide one opportunity for playing with loose and/or liquid materials. Example: sand, dirt, water, gravel, rice.
- Create pathways that undulate and/or have texture built into them for fun wheeled play.



PR-11 | AUDITORY

INTENT

Include events in the play space that assist the development of the auditory system.

STRATEGIES

- Provide pieces of equipment that create sound or enable a person to hear another person talking from a distance.
- Use different ways to generate sound.
- Choose a piece of equipment where the child creates a sound by activating a piece of equipment, Example: pushes a button and a sound comes out or hits a drum.
- Child creates a sound and then hears the sound repeat. Example: talking tubes or items that echo.
- Choose equipment that generates a sound. Example: by walking across or entering an area a sound is created.
- Place sound, echoes/acoustics, and activities with interactive sound and movement at the end of a ramp or other pathway to provide interest and reward for effort. This can also be done with tactile and other sensory activities.

Note: Care must be taken to locate these activities such that families can interact or remove themselves as needed.

PR-12 | VISUAL SENSORY SYSTEM

INTENT

Include activities and equipment in the play space that assist development of sight and the visual sensory process.

Visual processing refers to a group of skills used for interpreting and understanding visual information. Here are just a few things that the visual system deals with:

- Seeing something and remembering what was seen. The sense of sight involves the brain and visual recognition.
- Writing information accurately.
- Moving the eyes in a specific direction with or without distraction; tracking things with the eyes.
- Strengthening of the eye muscles.
- Focusing on an object.
- Seeing the differences between objects that are similar but not identical.

STRATEGIES

Most of the strategies that can help children improve their visual sensory system have already been addressed in other areas of the Play Richness section: swinging, spinning, balancing, using complex textures that resemble nature (artificial grass, trees and rocks).

If play panels are used in the play space, choose ones that will help develop the visual system. Example: tracing or tracking, looking at a picture and then recalling what it is, looking at a partial picture and have to determine what the whole picture is, games that involve matching.

NOTE: A developmental optometrist can help select appropriate activities.

PR-13 | INTERACTION WITH NATURAL FEATURES

INTENT

Enable children to engaging in nature in order to provide a wide-ranging benefit for children including the development of their cognitive and creative skills. Natural features include trees, shrubs, grasses, bark, soil, sand, water and rocks.

STRATEGIES

- Include thoughtfully placed landscaping throughout the play space. Refer to LA-10.
- Add a sensory garden to the play space.
- Install raised planters as well as wide paths through the plantings
- Add items found in a nature playground such as logs, rocks, water, hills, etc.
- Include a range of planting types to encourage play, such as tree climbing, weaving through dense planting and hiding in bushy cubbies.
- Plant specific items that encourages birds, mammals and insects;
- Include diversity of vegetation throughout the play space, instead of having it all in a separate sensory area
- Include a selection of plants that create loose parts such as pine cones.

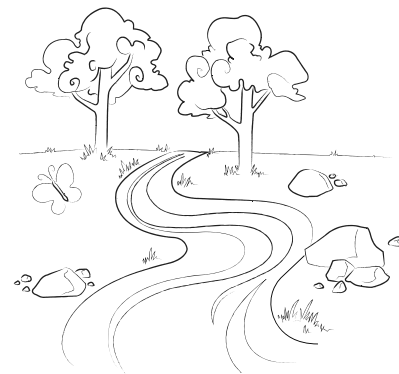

PR-14 | COZY PLACES

INTENT

Provide a place on the playground where a child can go to decompress or relax when overstimulated.

STRATEGIES

Provide at least one location within the play space where a child can go and feel alone. The place should feel to the child that he is enclosed, but the play piece must enable the caregiver to see the child. Example: an area under the play structure, a piece of equipment a child can go into, a nature area where tall plants or vines provide quiet, a playhouse, a tunnel with a window.

SOCIAL

PR-15 | COOPERATIVE PLAY

INTENT

Ensure that children learn how to play with each other. To teach skills required for cooperation.

STRATEGIES

- Provide a piece of equipment that requires two or more people to operate it. Example: seesaw.
- Provide a piece of equipment that will do additional things when more than one person is playing with it.
- Include pulleys and scoops on upper and lower levels which rely on someone at ground level as well as someone above; ensure the pulleys and conveyor belts are reachable as described in (AC-1)

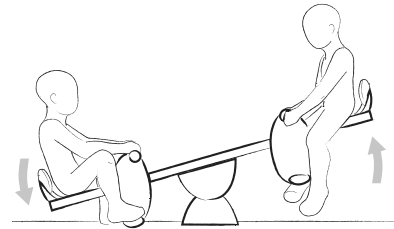

PR-16 | SOCIAL INTERACTION

INTENT

Encourage and enable social interaction and eye contact between children while playing on the playground.

STRATEGIES

- Include built features, equipment or space that encourages interaction while playing with others.
 - Examples:*
 - Games: basketball hoops, tether ball, seesaws, hopscotch, four square, electronic games designed to be used by multiple players
 - Seating: groupings of seats in close proximity
 - Sensory Play: water features, sand play, nature play
- Provide play areas where the younger children can watch and copy the actions of the older children. This enables children to learn from their peers (and older peers) instead of just their parents or caregivers.

PR-17 | DRAMATIC & IMAGINATIVE PLAY

INTENT

Provide opportunities for children to create play “themes” and act them out by participating in various roles that are spontaneous, child-initiated, and open-ended.

Expand a child’s awareness of self in relation to others and their social environment by providing dramatic play opportunities.

Provide opportunities through dramatic play for children to learn language, cognitive and social skills.

STRATEGIES

- Provide a space that fosters dramatic play opportunities within the play space. The space should allow children to create dramatic play experiences through the use of a mixture of abstract and realistic play events. Example: Themed structures, a stage, a playhouse made of natural materials.
- Utilize play spaces under the equipment or somewhere on the play structure for dramatic and imagery play. If it is on the structure, it must be on an accessible route. If the space is under the play structure ensure there is enough head room for a person using a wheelchair to enter.
- Provide a space where children can gather to plan and create their dramatic play.
- Provide children with opportunities to create varied individual and group dramatic play episodes throughout the play space and assist them in understanding the world around them through their play experiences.
- Use dramatic play panels above and below play decks, independent of the composite play structure that allow children to create dramatic play experiences that are based on the real world around them and on their own imagination.
- Use representations of real world activities and experiences, both abstract and realistic that are designed to create real world experiences that may be used by an individual or group of children.
- Create small semi-private spaces that encourage dramatic play by an individual or group of children.
- Use various play equipment that allows children to experience movement or stillness during their dramatic play.
- Include things which are easy to manipulate for creative play and do not require great physical strength or fine motor skills.
- When using wheels spinning items and steering wheels for imaginative play ensure that they have spokes or knobs to grasp (rather than a solid wheel) to assist a child with limited mobility to actively engage in the play.
- Provide loose parts such as props and costumes (see PR-18).

PR-18 | LOOSE PARTS

INTENT

Provide easily moved materials to assist children in manipulating and changing their environment, and provides opportunities for social, imaginative, and creating play experiences. Loose parts allow children to adapt and manipulate their play environment and help them gain confidence and independence thru their individual or group play experiences.

STRATEGIES

- Provide natural and/or synthetic materials that can be moved, carried, combined, redesigned, and taken apart and put back together in multiple ways with in the play environment and that may be used by children to enhance their individual or group play experiences. Such as:
 - Various sized building blocks and/or construction materials.
 - Materials and props that may be used for dramatic play.
 - Movable game or sports materials that children may use in individual or group games.
 - Sand and/or water toys that may be used during sand and water play
 - Items from nature (e.g. twigs, stones, leaves, pine cones)

Work with a local occupational therapist to add simple adaptations to the loose parts to make them more usable by children who are working on their fine motor skills.



inclusive play
design guide

SELECTING PLAYGROUND EQUIPMENT



SELECTING PLAYGROUND EQUIPMENT (SE)

INTENT:

The goal of this section is to encourage conscious and well thought out decisions when determining what types of equipment to purchase and where to place them. The planning committee should have in-depth conversations to address the issues raised in this section, prior to purchasing any equipment. Equipment in this sense can mean manufactured playground equipment or natural elements that are used as play activities.

CONTENTS	PAGE
SE-1 Elevated Play	43
SE-2 Contiguous or Co-located Play	43
SE-3 Resting Point Near a Slide	44
SE-4 Color of Play equipment.....	44
SE-5 Rich Play Experiences at all Heights	44
SE-6 Multiple Levels of Challenge	45
SE-7 The Coolest Thing in the Playground	45

SE-1 | ELEVATED PLAY

INTENT

No discussion of inclusive playgrounds would be complete without a discussion on elevated vs. ground level play. Many children with and without disabilities like the experience of height. They like being above everyone else. Being above is exciting and gives a sense of achievement.

STRATEGIES

- There must be a reason to go up high. It could be an amazing view or play activities that are unique.
- Include activities on the highest platform a child to do if they do not want or cannot go down the slide. These activities should have a high play value and should be enjoyed by children with and without disabilities. (e.g. Periscopes, Musical Instruments)
- When not using a ramped system, the topography of the land can be used to create a hill above the playground where children could go up and look down on everyone else playing.
- The highest slide should be accessible via a ramp system or contoured path.

Elevated play must have a reward; an amazing view and/or several play activities for everyone. Elevated elements must not dominate an inclusive playground.

- Fiona Robbé – Creative Design Solutions for Everyone

SE-2 | CONTIGUOUS OR CO-LOCATED PLAY

INTENT

Invite engagement between children of diverse abilities. Encourage children of the same age, but different abilities to play in the same location. Achieve this by locating similar types of equipment, such as balance or climbing, in the same area.

STRATEGIES

- As described in Play Richness, there should be two or more things that do the same thing such as climbing, spinning, or swinging at different challenge levels.
- Connect similar play events (contiguous). If this is not possible, place the similar play event adjacent to one another (co-located).
- Play equipment challenges should be graduated to include people with a wide range of abilities.

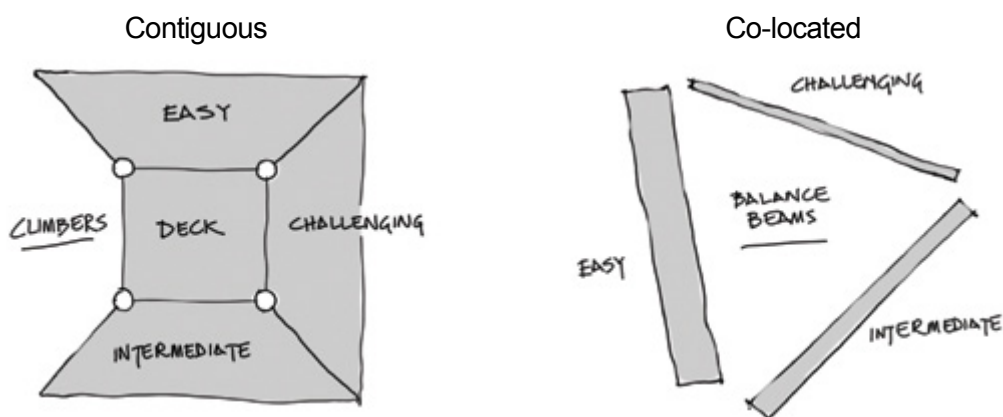



SE-3 | RESTING POINT NEAR A SLIDE

INTENT

Provide a resting point close to the slide exit for a person who uses a mobility device while it is being retrieved from the top of the slide.

STRATEGIES

- Place a seat with back support at the outside edge of the use zone for the slide. This keeps the child safe, preserves their dignity, and reduces the amount of distance they need to be carried.

SE-4 | COLOR OF PLAY EQUIPMENT

INTENT

Color is a stimulating input to the human brain. Adults tend to assume that brighter colors suggest a playful atmosphere, and the more the better. That may or may not be true for children and adults who process information in typical way. It is not true for people with Sensory Processing Disorder, Autism or Visual Perception issues. These people can be over-stimulated by color input.

Color can also be used as a wayfinding tool, providing contrast to children with low vision to help them determine where steps are on the play structure.

STRATEGIES

- The predominant playground equipment color should be a muted tone, rather than a primary color. Colors such as camouflage, beige, tan, brown, dark blue, dark green, grey, light blue, white (any color within white palette).
- Accent pieces can be accent colors.
- Material finishes should be matte rather than gloss. Shiny, reflective surfaces should be avoided as they can confuse people with a vision impairment
- The decks and steps (as much as possible) should have alternating colors to delineate where a child should step. People with low vision see yellow the best.
- The hand grips should use a high contrast (such as light yellow, when viewed against a contrasting background)

See using color as a wayfinding tool (LA-7) for specific ideas on contrasting colors.

SE-5 | RICH PLAY EXPERIENCES AT ALL HEIGHTS

INTENT

Encourage the play experiences available for a user at each height to have depth and breadth.

STRATEGIES

Include at each platform along the ramp circuit at least one activity for all children to do besides using the slide or going down a climber. Ensure that the activities are placed at heights that accommodate different reach ranges (AC-2). At each platform along the ramp circuit there must be at least one activity for all children to do beside using the slide or going down a climber. Example: periscopes, talk tubes, music or other auditory activity, pulley systems to send things up and down, activity panels that encourage more than one child to play with it at a time.

SE-6 | MULTIPLE LEVELS OF CHALLENGE

INTENT

Choose play activities that provide graduated levels of challenge to ensure that all ages and abilities are actively engaged on the playground.

STRATEGIES

- For each type of physical play, choose multiple pieces with different degrees of difficulty.
- Place the equipment together as described in SE-3.
- For the easiest challenge, consider creating ground levels patterns in surfacing as a play event. For the most difficult challenge choose equipment that requires a high level of motor planning.

SE-7 | COOLEST PLAY ACTIVITY

INTENT

Nothing excludes, separates and creates differences between children more than having the special piece of equipment that everyone wants to play on be inaccessible to some of them. Ensure that “the coolest” play activity is accessible and usable for all.

STRATEGIES

Examine the play activities chosen for the playground. Identify the one that will create the most excitement from children. Ensure that this piece can be played on by the vast majority of people. For example:

- Ensure that the most exciting slide has ramps leading to it and the ability to easily transfer.
- A web net that is easy to use at the ground level and then more advanced as it goes up.
- A wheelchair accessible glider.
- Water play that enables a child to control when they engage with the sensation and access for all has been considered.



inclusive play
design guide

SUPPORT FEATURES



SUPPORT FEATURES (SU)

This section discusses the support systems and the built environment surrounding the play space to maximize inclusion.

INTENT:

Provide supportive infrastructure and amenities that are inclusive, safe, and easy to use by people of all abilities. Design a playground with inclusive comfort facilities and ensure inclusion throughout the site and play environment. Some of the concepts in this section are from the Global Universal Design Commission, who is currently developing UD voluntary consensus standards for commercial buildings. For more information visit www.globaluniversaldesign.com.

CONTENTS:	PAGE
SU-1 Seating	49
SU-2 Restrooms	49
SU-3 Drinking fountains.....	49
SU-4 Picnic tables.....	50
SU-5 Parking.....	50
SU-6 Trash cans	51
SU-7 Shade.....	51
SU-8 Cooling devices	51
SU-9 Service animals	52
SU-10 Emergencies.....	52
SU-11 Alternative Transportation	52
SU-12 Signage Visibility.....	52
SU-13 Introduction to the Play Space	53
SU-14 Public Statement of Inclusive Play..	53

SU-1 | SEATING

INTENT

Provide a variety of types of seats for caregivers and children of all abilities to rest in proximity to one another and to the play space.

STRATEGIES

- Allow space next to a bench for a wheelchair to pull up to it.
- Orient the seating for the best vantage points for caregivers to supervise children during play. Seating should be closer to the play areas where younger children will play and a little further back for older children.
- Install a seating area in each play area.
- Strategically place play equipment that can be used for caregivers to sit on.
- Include benches with, and some without arm rests to allow someone in a wheelchair to transfer to them.
- Locate seating so the user is protected from wind and provide thermal comfort in all seasons on a universal route.
- Use lightweight, movable furniture where local security allows.
- Ensure that seating and tables in each area accommodates a wide range of statures, mobility levels and perceptual abilities.

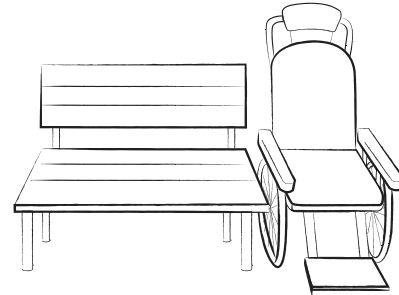

SU-2 | RESTROOMS

INTENT

Provide toilet facilities for all members of a family.

STRATEGIES

- Build a permanently installed structure that is plumbed into local sewage, water and electrical systems.
- Comply with ADA regulations as a bare minimum.
- Include a family restroom that has a changing table capable of accommodating an adult body.

SU-3 | DRINKING FOUNTAINS

INTENT

Allow everyone at the playground the ability to drink water while they are there.

STRATEGIES

- Include at least two different heights of fountains.
- Utilize water fountains that turn on when the unit senses someone within its perimeter.
- Provide a facility for filling up personal water containers
- Provide drinking fountains that can be operate by a lever rather than a button.

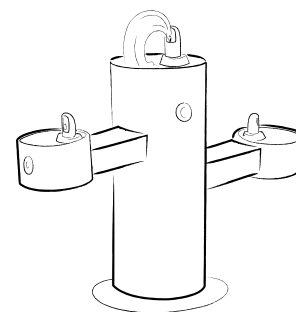



SU-4 | PICNIC TABLES

INTENT

Allow everyone to eat and feel included in the activities. Too frequently wheelchair spaces are in less than optimal locations.

STRATEGIES

- Use accessible picnic tables positioned so that the open space for the wheelchairs are looking out in different directions.
- Choose seating and tables in each area that accommodate a wide range of statures, mobility levels and perceptual abilities.
- Include child-sized picnic tables with wheelchair places.
- Allow space for more than one wheelchair. This not only offers a chance for multiple people who use wheelchairs to sit comfortably at the same table, but also offers a choice of where each person may sit.
- Position wheelchair spaces for social interaction. A space in the middle of the table places a person who uses a wheelchair closer to their friends and family increasing social interaction rather than always having to sit at the end of the table. In addition, for a parent with more than one child, a seat in the middle of the table enables the parent to care for multiple children by sitting in between them.
- Allow for extra leg space and knee clearance.
- Provide a larger surface area than required around the tables for easier manipulation around the space. Increase number of fixed accessible tables to prevent displacement of tables. If accessible tables are moved away from their firm and stable surface, they are no longer accessible.
- Place some tables in the sun and some in the shade.

SU-5 | PARKING

INTENT

Ensure that parking spaces are provided for people who need their vehicle to be close to the play events as well as provide a safe parking lot.

STRATEGIES

- Exceed the spacing between van parking by 20% greater than the local standards. Meet or exceed all other local standards in regard to parking. Users of van parking often find they do not have enough space between the vehicles, even though the space is technically compliant.
- Provide accessible parking spaces close to the play area. This does not mean that the whole parking area needs to be located nearby. For site design or aesthetic reasons the accessible parking spaces may need to be separated from and closer to the playspace than the rest of the parking area.
- Install seating in the designated loading and waiting areas.
- Separate vehicular travel routes from pedestrian routes in the parking lot.
- Protected pedestrian routes/islands are provided (Example: landscaped area with a sidewalk.)
- Provide temporary loading/unloading area for buses near the primary entrance or designated entrance for tour buses.
- Provide a designated parking area for buses, RVs, and other larger vehicles away from primary entrances.
- Create separate areas for different transportation modes (e.g. automobiles, transit, rickshaws/pedicycles)

SU-6 | TRASH CANS

INTENT

Make waste receptacles convenient for use by everyone.

STRATEGIES

- Ensure that receptacles can be used with only one hand. Example: open tops, slots, and push doors.
- Provide receptacle covers operated by motion detectors.
- Receptacles should be on an accessible route.
- Trash cans should not be located within eating areas, but placed at exits of each area.
- Do not locate trashcan in clear spaces next to benches, since those spaces may be needed for people in wheelchairs in order to be close to people on the bench.

SU-7 | SHADE

INTENT

Provide spaces within the playground where a child is not in direct sunlight. Adults and children with sun allergies and those susceptible to sun poisoning are not able to go to standard playgrounds where shade is not provided.

STRATEGIES

- Use established shade trees.
- Use a freestanding fabric shade structure.
- Utilize fabric structures on top of the equipment.
- Consider shading some of the seating or gathering areas.

NOTE: the shade provided by a new tree will be very different than that provided by that same tree in 10+ years.

SU-8 | COOLING DEVICES

INTENT

Allow children of all abilities to cool down.

STRATEGIES

- A water feature that is usable by a child or adult regardless of their mobility device. Example: water misters. Do not put them on a play structure as it as it can create a risk of slipping,
- Water spray pad.



SU-9 | SERVICE ANIMALS

INTENT

Allow children and adults who depend on a service animal to use the play space.

STRATEGIES

- Include signs that prohibit curbing service animals without collecting and disposing of waste. Provide for appropriate waste disposal.
- Include a designated area on site provided for animal care, ensuring that it is on a universal route.
- Provide water trough or basin for use by pets and service animals

SU-10 | EMERGENCIES

INTENT

Enable the people at the play space to reach emergency services. Not everyone has a cell phone, and if they did, in the event of a parent becoming ill the child may not know how to find the cell phone or use it.

STRATEGIES

- Include emergency call boxes. Ensure that they are clearly marked and are usable by someone using a wheelchair.

SU-11 | ALTERNATIVE TRANSPORTATION

INTENT

Allow people who cannot drive or do not have a car to use the playground.

STRATEGIES

- Locate transit stops near primary entrances. Provide route and scheduling information in both print and audible modes.
- Place transit stops separate from other vehicular loading and unloading zones in front of playground entrance.
- Provide a protected area (from weather and other obstacles) that accommodates at least one personal wheeled mobility device.
- Provide bike racks near the primary entrance for those patrons who wish to bike to the play space.
- Consider adding a “parking lot” immediately inside the entry way to park strollers, wheelchairs, and other adaptive equipment such as a cane or walker.

SU-12 | SIGNAGE VISIBILITY

INTENT

Allow signage to be legible to all readers.

STRATEGIES

- Review ADA signage rules.

- Text is large enough to read from the expected viewing distance (see ADA requirements).
- Surfaces are free from glare from the expected viewing location.
- Make alternatives to text available, e.g. audible and/or tactile modes. Volume adjustment provided for audible displays. Device triggers audible information by proximity.

SU-13 | INTRODUCTION TO THE PLAY SPACE

INTENT

For many people with a disability, a significant amount of effort is required to get out of their house. For a trip to be enjoyable, information about access, public transportation, layout of space, activities included, and accessible facilities, such as restrooms, needs to be provided ahead of time for that person to make sure their effort will not be wasted. Allow parents to work with their child prior to leaving home to understand the layout, play equipment, and overall play space. This type of preparation makes it much easier for a child on the Autism spectrum to go to a new place.

STRATEGIES

- Create a website and other marketing material for the playground. At a minimum include:
 - A brief description of the spaces and its major features
 - Directions to reach the playground, including public transportation
 - Whether the playground is fenced
 - Whether the playground has accessible features such as restrooms and picnic tables
- Offer orientation materials to prepare a child for their visit: a video, a virtual map, a printable map.
- Develop flashcards that can be printed out of the different areas so that a child can point to where they want to go. They will enable a parent or caregiver to create Story Boards for child to prepare them for their visit.
- It is assumed that additional technology will evolve to create new ways to prepare a child for their visit, and they should be used to help in this way.

SU-14 | PUBLIC STATEMENT OF INCLUSIVE PLAY

INTENT

Educate the public about universal design at a local level. Make a clear statement to the community about the goals of the playground.

STRATEGIES

- A sign at the entrance of the park which explains the purpose of the playground.
- Audio button that is pushed to receive information about the playground.
- Signage at each station that explains why the type of equipment was chosen. The heights should accommodate children adults and meets ADA signage requirements.

GLOSSARY

ACCESSIBLE ROUTE An ADA term referring to the route within the boundary of the site which provides access from public transportation stops, accessible parking, accessible passenger loading zones, and public streets or sidewalks to the play activity. The accessible route shall, to the maximum extent feasible, coincide with the route for the general public.

AUTISM SPECTRUM DISORDER Autism, part of a group of disorders known as autism spectrum disorders (ASD), is a complex neurobiological disorder that typically lasts throughout a person's lifetime. The disorder is characterized by varying degrees of impairment in communication skills and social abilities, and also by repetitive behaviors. Symptoms range from mild to severe.

BIRD NEST SWING OR BASKET SWING A type of swing that consists of a suspended shallow basket that usually swings in a planar (back and forth) motion. This type of swing is considered more inclusive since the user can lie, sit or stand as their ability allows. It also invites more than one user, creating a social capability.

CEREBRAL PALSY (CP) A blanket term commonly described by loss or impairment of motor function. It is caused by brain damage which typically occurs before birth, during birth, or immediately after. CP affects body movement, muscle control, muscle coordination, muscle tone, reflex, posture and balance. It can also impact fine and gross motor skills.

COCHLEAR IMPLANT This is a surgically implanted electronic device that provides a sense of sound to a person who is profoundly deaf or severely hard of hearing. Cochlear implants are sometimes referred to as a 'bionic' ear.

COMMUNITY BUILD The members of the community share their energy and time to assemble and install the playground equipment

CROSS SLOPE The slope that is perpendicular to the direction of travel

DOWN SYNDROME Down syndrome occurs when some or all of a person's cells have an extra full or partial copy of chromosome 21. People with Down syndrome have an increased risk for certain medical conditions such as congenital heart defects, respiratory and hearing problems, Alzheimer's disease, childhood leukemia, and thyroid conditions. All people with Down syndrome experi-

ence cognitive delays, but the effect is usually mild to moderate and is not indicative of the many strengths and talents that each individual possesses.

COGNITIVE DISABILITIES

See intellectual disabilities.

FLUSH TRANSITION The relationship between two sections of flooring materials. 'Flush' means there should be no height difference between the two sections. In reality, there will be a difference and it may be measurable. Acceptability can be defined by quantifying what this difference should not exceed. Smaller wheels on mobility devices will have more problems than larger wheels when moving across a non-flush transition.

GROSS MOTOR FUNCTION CLASSIFICATION SYSTEM (GMFCS) A five level classification system that describes the gross motor function of children and youth with cerebral palsy on the basis of their self-initiated movement with particular emphasis on sitting, walking, and wheeled mobility. Distinctions between levels are based on functional abilities, the need for assistive technology, including hand-held mobility devices (walkers, crutches, or canes) or wheeled mobility, and to a much lesser extent, quality of movement.

IMPACT ATTENUATION SURFACE A surface that absorbs the force of a falling body.

INCLUSIVE The ability to include everyone, regardless of physical or psychological situation.

INTELLECTUAL DISABILITY A term used when a person has certain limitations in mental functioning and in skills such as communicating, taking care of him or herself, and social skills. These limitations will cause a child to learn and develop more slowly than a typical child. Children with intellectual disabilities (sometimes called cognitive disabilities or mental retardation) may take longer to learn to speak, walk, and take care of their personal needs such as dressing or eating. They are likely to have trouble learning in school. They will learn, but it will take them longer. There may be some things they cannot learn.

KABOOM! KaBOOM! is a national non-profit dedicated to saving play for America's children. Their mission is to create great playspaces through the participation and leadership of communities. Ultimately, they envision a place to play within walk-

ing distance of every child in America.

LOCOMOTOR SKILL Motor skills in which the feet move the body from one place to another. They are (roughly in order of how children learn them): walking, running, hopping, jumping, skipping, galloping, sliding (a sideways gallop), leaping.

MODULAR SYSTEM OR COMPOSITE

STRUCTURE A composite play structure consists of two or more play components/events attached or an integrated unit providing more than one play activity.

MOBILITY DEVICES A mobility device is a mechanism such as a wheelchair, a transfer chair (also called a convertible or stretcher chair), a sling lift, a sit-to-stand lift, a hobcart, or calipers, designed to aid individuals with mobility impairments. They can be either powered or manually operated.

MOTOR PLANNING Motor planning or praxis is the ability of the brain to conceive, organize, and carry out a sequence of unfamiliar actions. In the playground this includes walking, climbing, running and/or any unfamiliar activities that do not have consistent, predictable steps to follow or outcomes.

MULTIPLE TOUCH POINTS The number of points at which a child makes contact with the play activity or ground surface. If a child is hopping on one leg they have one touch point, while crawling they have four.

OVERHEAD EVENT An overhead event is one that the user hangs from, or moves themselves across using their hands and upper body.

PERCEPTUAL MOTOR SKILLS The muscles cannot work in isolation. They are in constant contact with the brain and visual sensory system to ensure the action is doing what is required. Gross motor skill requires controlled movement of most, if not all, of the body to perform a task. Fine motor skill is the ability to manipulate small and delicate objects. Children develop most of their gross motor skills, such as moving arms and legs, before accomplishing fine motor skills like writing. Both are essential to the growth and development of children.

PERIMETER BOUNDARY When used in connection with inclusive play, this is a fence or wall with a limited number of openings. This will prevent a child who tends to run when overstimulated to be hurt by hazards that may be near the playground.

PLAY EVENT An individual play event. Slides and swings are play events. If the structure is modular, it could have many play events.

PROPRIOCEPTIVE SENSORY SYSTEM

The proprioceptive system consists of sensory information caused by contraction and stretching of muscles and by bending, straightening, pulling and compression of the joints between the bones. Because there are so many muscles and joints in the body, the proprioceptive system is always at work. Most proprioceptive input is processed in areas of the brain that do not produce conscious awareness. Without good automatic responses, such things as eye-hand coordination are very difficult.

ROLLER SLIDE Rollers are built into the bed of the slide.

RUNNING SLOPE The slope that is parallel to the direction of travel

SENSORY PROCESSING DISORDER (SPD)

Formerly known as “sensory integration dysfunction,” SPD is a condition that exists when sensory signals don’t get organized into appropriate responses. Pioneering occupational therapist and neuroscientist A. Jean Ayres, PhD, likened SPD to a neurological “traffic jam” that prevents certain parts of the brain from receiving the information needed to interpret sensory information correctly. A person with SPD finds it difficult to process and act upon information received through the senses, which creates challenges in performing everyday tasks. Because of motor clumsiness, anxiety towards people, and/or new or certain activities, social interaction difficulties, auditory and visual disturbances, balance and performance problems: SPD can make simple “play” difficult.

SPATIAL AWARENESS A well thought-out awareness of things in the space around us. It also deals with the awareness of our body’s position in space. Without having spatial awareness, we would not be able to turn the page of a book. Without spatial awareness, we would not be able to drink from a cup. Enhanced spatial awareness plays a crucial role in sports and games.

SPINA BIFIDA The words Spina Bifida mean “split spine.” Spina Bifida happens when a baby is in the womb and the spinal column does not close completely. Spina Bifida is the most common birth defect that disables people for life. Every day, about eight babies born in the United States have Spina Bifida or a similar birth defect of the brain and spine. Children

PLAYGROUND SURFACING

FREQUENTLY ASKED QUESTIONS

What is playground surfacing?

A playground's surface is the material that lies directly beneath and around swings, slides, and other playground equipment. Many playground surfaces are designed with a specific purpose in mind:

- Child safety
- Wheelchair accessibility
- Aesthetics
- Cost

What types of surfacing are available?

There are two categories of surfacing material: unitary and loose.

Unitary Surfacing Material — A manufactured material used for protective surfacing in the use zone that may be rubber tiles, mats, turf or a combination of energy absorbing materials that forms a unitary shock absorbing surface. The following are examples of unitary surfacing materials:

- Pour-in-place rubber
- Rubber Tiles
- Playground turf

Loose-Fill Surfacing Material — A material used for protective surfacing in the use zone that consists of loose particles. These surfaces can meet minimum ADA guidelines if it is installed properly. ongoing maintenance is required to maintain compliance.

The following are examples of Loose-Fill Surfacing Material:

- Engineered wood fiber (EWF)
- Rubber mulch

Why is surface selection important?

While many surfaces meet the minimum United States ADA accessibility guidelines, not all surfaces fully meet the standards for accessibility that should be considered as 'minimum' for the guidelines set forth in this design guide. Due to variations in the type, quality and general maintenance of loose-fill surfacing material, the members of the work group feel that it is functionally non-compliant. In order to maintain an high level of accessibility the work group feels that a unitary surface material should be selected as the preferred alternative. (See AC-1)

What are the advantages and disadvantages of different types of surfacing?

	ADVANTAGES	DISADVANTAGES
Engineered Wood Fiber	<ul style="list-style-type: none"> • Wheelchair accessible (with proper maintenance) • Fairly durable • Easy to obtain • Retards insect infestation and fungal growth • Free of bark and leaves • Low initial cost 	<ul style="list-style-type: none"> • Can conceal animal excrement or dangerous sharp items • Microbial growth when wet • High humidity and freezing temperatures can reduce its effectiveness • Decomposes and contracts over time. • Can easily be displaced to areas outside the playground • Requires regular replenishment • Requires high on-going maintenance and associated costs • Parents report that children pick it up to play with or mouth it.
Pour-in-Place	<ul style="list-style-type: none"> • Wheelchair accessible • Stays in place • Lower maintenance costs over long term • Graphics can also be incorporated into the play surface adding play value. 	<ul style="list-style-type: none"> • Requires professional installation • Wide variation in quality • Can become hard over time • Must be swept free of dirt and other debris that can collect and decrease its shock absorption • May require annual deep cleaning to remove debris from air pockets in order maintain shock absorption
Playground Tiles	<ul style="list-style-type: none"> • Wheelchair accessible • Stays in place • Easy to clean • Consistent impact-absorbing qualities • Manufactured in a quality controlled environment • Lower maintenance costs over long term • Very durable • Tiles may be placed individually 	<ul style="list-style-type: none"> • Requires professional installation • Quality varies by manufacturer • May separate or shift if not installed professionally
Playground Turf	<ul style="list-style-type: none"> • Wheelchair accessible • Stays in place • Consistent impact-absorbing qualities • Lower maintenance costs over long term • Looks like natural grass which may increase the play value 	<ul style="list-style-type: none"> • Requires professional installation • Quality varies by manufacturer • If the playground is higher than 12', the turf may not meet standards. • It may be hot or create static. Ask the manufacturer what is done to mitigate against this.

PLAYGROUND TESTING AND TECHNICAL INFORMATION

What is ASTM F1292? It is the standard specification that provides a uniform means of quantifying the impact absorbing properties of playground surfaces and is appropriately used to compare the relative performance of different playground surfacing materials.

How do I know if the product I am purchasing is complaint with ASTM 1292? Every product and/or manufacturer should be able to provide you with a certified test report listing the ASTM F1292 results for their surfacing product. Also consider requiring the installer to conduct a post installation field test to determine if the surface installed and paid for actually meets the safety standards on day one. If not included in the work specifications, ensure that the budget reflects the cost of the testing.

How are compliance tests conducted? A metal “head-shaped” instrument is dropped onto the surfacing sample which sends key measurements to a computer upon impact. Two key impact absorbing properties are measured. They are the HIC (head injury criteria) and the GMAX and they both relate to the ability of the surfacing system to absorb impact or cushion falls. The standard allows for a maximum HIC reading of 1000 and a maximum GMAX reading of 200. In order for a surface to meet the standard, it must provide readings below these numbers at a pre-specified height. The key concept is that these values are the maximum threshold which must never be exceeded at any time over the entire life cycle of the product.

How do I make sure the product is compliant throughout the life of the product? Look for the lowest possible HIC rating within your budget. This helps to ensure that the surface remains compliant for many years. Examine the warranty offered by the manufacturer. Determine if the written warranty guarantees that the surfacing will be complaint with ASTM F1292 throughout the length of the warranty.

WORK GROUP

INCLUSIVE PLAY WORK GROUP MEMBERS:

Experts and Parents from Across the Country



JC Boush (California) is a play consultant, head playground designer for Design for Play, and a specialist in child development. He has lectured worldwide, presented several training webinars for KaBOOM! Head Start Body Smart, and Peaceful Playgrounds as well as authored numerous articles and blogs on play, brain development, and children's play environments.



Cindy Burkhour (Michigan) is a Certified Therapeutic Recreation Specialist and Certified Park and Recreation Professional who has consulted around the country on a variety of recreation issues in the areas of inclusive recreation, universal design and the Americans with Disabilities Act (ADA). She was the director of a community recreation department and coordinator of therapeutic recreation services for a community recreation program. Cindy has taught therapeutic recreation and adapted physical education at several universities in Michigan. Cindy has been active in working with persons with disabilities her entire life. She has a sibling, who has multiple physical and mental impairments, and she is also the parent of a child who faces a variety of challenges after experiencing several massive strokes. She advocates professionally and personally for the rights of ALL people to be included in all aspects of community life.



Jim Dziatkowicz, (Ohio) RLA, ASLA, has 17 years' experience as a landscape architect within the parks and recreation arena. He assists communities in the planning and design of parks, open recognized leader in his field and has recently been appointed to serve on the Ohio Parks and Recreation Association Board of Directors.



Carrie Fannin (Washington) is the founder of the social network Sensory Planet: One Puzzle, Many pieces. The goal of the network is to bring a positive, purposeful and valuable social network community to those whose lives are affected by Sensory Processing Disorder (SPD). Carrie is the managing director of The Children's Institute for Learning Differences located on Mercer Island, Washington and is raising a daughter with SPD.



Blake Hobson (Ohio) has been a playground consultant and sales representative for over twenty years. More importantly, as a father, he has walked in the shoes of parents who have children with significant challenges. He knows the paths are emotional, physically challenging and frustrating, not only for the child, but also the child's parents, siblings, grandparents and caregivers. Since 1993, Blake has observed children and adults with disabilities struggle to play. He has watched loved ones and caregivers become exasperated and saddened as they try to enjoy what should have been a pleasant outing. Instead, these play areas provided limited and frustrating opportunities. Today, Blake is more committed than ever to help playground decision makers understand the importance of inclusive play.



Christopher Joseph (Maryland) is the director of physical therapy at the Kennedy Krieger Institute. Chris received his master's degree in physical therapy from Thomas Jefferson University in 1994. He has been practicing in the field of pediatrics for 17 years and has worked in inpatient and outpatient rehabilitation, schools, patients' homes and in the early intervention field. Chris also has a background in motor learning and motor control in children and brings a unique perspective to the team regarding how children with disabilities move through space.



Mara Kaplan (Pennsylvania) is an educator, a seasoned advocate for inclusive play and a parent of a child with a disability. She has over 17 years' experience reviewing toys and designing playgrounds. Her firm, Let Kids Play, designs accessible playgrounds, reviews and recommends toys for children with disabilities, and operates the website accessible-playground.net. Mara is a certified playground safety inspector. Mara also speaks about her journey as parent of a child with severe disabilities as well as universal design, inclusive playgrounds, playgrounds for children with autism, inclusion and other topics. In conjunction with Ian Proud, Mara facilitated the creation of the Inclusive Play Design Guide and was an active member of the working group that wrote the document. Mara has an elementary education degree from Indiana University in Bloomington, IN and an MBA, with a concentration in nonprofit management, from Boston University.

REVIEWERS

Thanks to the following people who reviewed the **Inclusive Play Design Guide**.

Lynn A. Barnett, Ph.D. is Associate Professor in the Department of Recreation, Sport and Tourism at the University of Illinois in Urbana-Champaign. Her areas of interest include analysis of play and its relation to development; investigation of toys and play spaces as facilitative of play; and resources in research design and statistical analysis. Professor Barnett-Morris' areas of research include theoretical formulation of children's play; intrinsic motivation and rewards; and the play of children with special challenges and needs.

Norman K. Booth, FASLA is a registered landscape architect, photographer, outdoor enthusiast, and professor emeritus at The Ohio State University where he taught landscape architectural design and site planning courses for 31 and half years at both the undergraduate and graduate levels. He is the author of several books, including *Foundations of Landscape Architecture*. It is his belief that good landscape design is a hands-on craft that is founded on a thorough understanding of fundamental design principles and theories.

Cathy DeLeon, OTR/L is the Director of Clinical Services at Developmental Therapy Services (DTS), a division of The Children's Institute for Learning Differences (CHILD) located on Mercer Island, Washington. DTS provides occupational, speech and mental health therapy services to children ages 3 to 17.

Teresa (Teri) B. Hendy, CPSI is the President and owner of Site Masters a design and safety consulting firm. Teri brings extensive knowledge of the standards and guidelines that apply to the playground industry as she has actively worked with the ASTM subcommittees and the Consumer Product Safety Commission since 1987. Teresa is a nationally recognized author, speaker and expert in the area of playground safety and design.

Rebecca Ho is the Playground Project Manager for the Australian charity, Touched by Olivia Foundation, who are building 42 inclusive playgrounds across Australia. With a background in marketing and social media, Rebecca brings together the government, corporations and community in a unique partnership to create truly inclusive play spaces where people of all abilities can happily play side by side.

Carol A. Krawczyk has more than 24 years' experience as a landscape architect in the public and private sector. Krawczyk specializes in research-based design. Since 1996, Krawczyk has taught courses in landscape design, construction methods, detailing, planting design and therapeutic garden design at the University of Delaware, Temple University, Longwood Gardens Continuing Education, and the Coastal Georgia Center for Continuing Education.

Laurie Renke has been advocating for children and families whose lives have been touched by SPD for over a decade. She was the founder of SPD Parent Connections, a grass roots effort offering parent support and education. Laurie is the author of the Children's book *I Like Birthdays....It's the Parties I'm not sure about!* Her efforts to bring SPD into the mainstream continue.

Ben Richards is a playground designer who specializes in the design of inclusive public playgrounds. His particular interests are in making public space and play less threatening and more accessible to those with physical and neurological impairments. He also believes that for play to be truly inclusive it has to be inter-generational



and cater to all ages as well as all abilities. Ben won Best Playground in New South Wales, Best Playground in Australia and a Special State Community Award in 2010 as well as being a finalist in the 2011 Australian National Disability Awards.

Fiona Robbé is a registered Landscape Architect. Fiona has specialized in the design of outdoor children's environments for the past ten years. Her work encompasses public playgrounds in parks (local and state government), as well as play areas in schools, preschools, churches and other institutions. Fiona's commitment to design of quality playgrounds includes daily advocacy for the rights of children of all ages and abilities to play outdoors safely, regularly and imaginatively.

RESOURCES

ADA AND OTHER ACCESSIBILITY RESOURCES

ADA Checklist for Readily Achievable Barrier Removal - This checklist is based on the 2010 ADA Standards for Accessible Design (2010 Standards). The specifications are in this checklist to help determine what may be readily achievable barrier removal for existing facilities. The checklist is a project of the Institute for Human Centered Design. <http://www.adachecklist.org/>

Americans with Disability Act - Website with all of the information about ADA. <http://www.ada.gov/>

National Accessibility Center (NCA) - The National Center on Accessibility promotes access and inclusion for people with disabilities in parks, recreation and tourism. NCA Research investigates the critical issues and challenges facing recreation professionals as they work to make their programs and facilities fully inclusive of people with disabilities. NCA Research is practitioner-based with end results focused on providing professionals with practical information to provide effective accessibility solutions. CA Education programs are designed to engage practitioners in recreation access issues with instructors nationally recognized for their expertise and commitment to inclusive recreation environments for people with disabilities. NCA also provides technical assistance and consultations. <http://www.ncaonline.org/>

United States Access Board - A federal agency committed to accessible design. <http://www.access-board.gov/>

PLAYGROUND RESOURCES

A Guide to Playground Planning (<https://dnr.state.il.us/ocd/IDNRPlaygroundManual.pdf>) Distributed by the Illinois Department of Natural Resources - It includes information about site selection and preparation, budget, ADA, installation, and maintenance. Includes helpful checklists and sample forms. Published 2004.

Accessibleplayground.net is the home for accessible playgrounds on the web. The site is dedicated to helping people find all the resources needed to design and build a playground that goes far beyond ADA. Here you can use the directory to find a playground in the United States or Canada; learn about inclusive play; read stories of how others built their playground; and see pictures of existing playgrounds and unique play equipment. <http://www.accessibleplayground.net/>

Canadian Association of Playground Practitioners (CAPP) – This is a voluntary, non-profit organization with an important mission - to act as a collective voice for the promotion of appropriate playground environments. <http://www.capp-online.ca/>

CPRA—Through the Everybody gets to play Initiative, the Canadian Parks and Recreation Association is creating awareness of the issue and providing the tools to help mobilize communities to provide recreation without barriers for kids without means. <http://www.cpra.ca/cpra>

The United States **Consumer Product Safety Commission (CPSC)** is an independent agency of the United States government. It was created in 1972 through the Consumer Product Safety Act. The CPSC is an agency that reports to Congress and the President and is not part of any other department or agency in the federal government. The CPSC regulates the sale and manufacture of more than 15,000 different consumer products including playground equipment. CPSC published the **Public Playground Safety Handbook**—(<http://www.cpsc.gov/PageFiles/122149/325.pdf>) The handbook presents safety information for public playground equipment in the form of guidelines. These guidelines are not being issued as the sole method to minimize injuries associated with playground equipment. However, the Commission believes that the recommendations in this handbook along with the technical information in the ASTM standards for public playgrounds will contribute to greater playground safety.

Inclusive Play Space (inclusiveplayspace.com)—is Australia’s website for advocating for inclusive playgrounds. The website provides accessible, informed guidance for the development of quality inclusive playspaces as well as examples, resources, references and networks from around the world to help make playspaces accessible to all.

IPEMA (International Playground Manufacturers Association) - Provides 3rd party Product Certification services for U.S. and Canadian public play equipment and public play surfacing materials in the U.S. They service IPEMA-certified member companies, affiliated playground industry groups and anyone with an interest in playground equipment regulations. <http://www.ipema.com/default.aspx>

KaBOOM! is the longest-running non-profit organization that specializes in linking communities and corporations together to build much-needed, safe and accessible playgrounds, and has helped build more playgrounds than any other service organization, making it the #1 playground facilitator of its kind. <http://www.kaboom.org/>

Let Kids Play was founded by Mara Kaplan and is a consulting firm that works with manufacturers, communities, non-profits, park districts, retail stores, and parents on projects and strategies that ensure that all children have the best play opportunities regardless of ability. <http://www.letkidsplay.com/>

National Recreation and Parks Association (NRPA)—(NRPA.org) The National Recreation and Park Association is a not-for-profit organization in the United States dedicated to advancing park, recreation and conservation efforts that enhance quality of life for all people. Through its network of 20,000 recreation and park professionals and citizens, NRPA encourages the promotion of healthy lifestyles, recreation initiatives, and conservation of natural and cultural resources.

Play by Playworld is the blog of Playworld Systems, an outdoor recreational equipment manufacturer. This is a discussion of play in the real world. That’s the world where we all need play, especially those who may not be average in any way. <http://www.playbyplayworld.com/>

Play Everyone’s Right – Design for Play has over nine years of experience in creating unique outdoor play environments and providing numerous learning opportunities in outdoor classroom designs. Design for Play’s playground services include playground design consulting, playground planning, and playground project management. <http://www.jcboushconsulting.com/>

Playgroundology scours the web for all things bright, beautiful and occasionally tarnished in the world of playgrounds. Find posts about design, art, civic engagement, history, equipment old and new, photography, advocacy groups, bloggers and oddities. <http://playgroundology.wordpress.com/>

Play Unlimited is a 501(c)3 non-profit organization that helps to plan, design and build fully accessible playgrounds that allow all children – regardless of their abilities – to play together. A valuable resource in our community, Play Unlimited has unique expertise in this area, and is available to assist in the development of inclusive playgrounds that promote dignity, understanding and respect among children. <http://unlimitedplay.org/>

Touched by Olivia - Since 2006, it has been the mission of the Touched by Olivia Foundation to help improve the health and happiness of Australian kids. One of their initiatives is focused on creating a level playing field for children with special needs. They help design all abilities playground that enable children and parents of all abilities and ages to play side-by-side on the same equipment, ensuring integration of children and families with special needs. <http://www.touchedbyolivia.com.au/playgrounds/>

Voice of Play - The “Voice of Play” website is IPEMA’s effort to educate the general public, parents, teachers, and organizations such as PTA, PTO and community groups about the various benefits of play. The website provides resources of the benefits of play and playground safety. <http://voiceofplay.org/default.aspx>

UNIVERSAL DESIGN

Center for Universal Design – a national information, technical assistance, and research center that evaluates, develops, and promotes accessible and universal design in housing, commercial and public facilities, outdoor environments, and products located at NC State. <http://www.ncsu.edu/project/design-projects/udi/>

Global Universal Design Commission - (GUDC) a not-for-profit corporation, was established to develop Universal Design (UD) standards for buildings, products and services. GUDC is currently developing UD voluntary consensus standards for commercial buildings, which will expand access to buildings for all people, regardless of physical stature and varying abilities. The approved UD standards will guide corporations and government entities in the creation of barrier-free facilities, providing diverse users with access to commerce, public services, entertainment and employment opportunities. <http://globaluniversaldesign.com/>

IDEA Center at Buffalo – is dedicated to making environments and products more usable, safer and healthier in response to the needs of an increasingly diverse population. They are located at Buffalo University. <http://www.ap.buffalo.edu/idea/>

Institute for Human Centered Design – Adaptive Environments (AE) is a 30 year old international non-profit organization, based in Boston, committed to advancing the role of design in expanding opportunity and enhancing experience for people of all ages and abilities. <http://www.adaptenv.org/>

Trace Center – Their mission is to prevent the barriers and capitalize on the opportunities presented by current and emerging information and telecommunication technologies, in order to create a world that is as accessible and usable as possible for as many people as possible. Located at University of Wisconsin. <http://trace.wisc.edu/>

Universal Designers & Consultants—is a world leading team of experts providing Universal Design and Accessible Design consulting services. <http://www.universaldesign.com/>

DISABILITY RESOURCES

Autism Speaks - is the largest autism science and advocacy organization, dedicated to funding research in the causes, prevention, treatments and a cure for autism; increasing awareness of autism spectrum disorders; and advocating for the needs of individuals with autism and their families. <http://www.autismspeaks.org/>

CanChild Centre for Childhood Disability Research is a research and educational center located at McMaster University in Hamilton, Ontario, Canada. Their research is focused on improving the lives of children and youth with disabilities and their families. <http://www.canchild.ca>

Center for Disease Control Fact Sheets — Fact Sheets on developmental disabilities, autism spectrum disorder, visual impairments, cerebral palsy, hearing loss, and intellectual disabilities. <http://www.cdc.gov/ncbddd/dd/default.htm>

National Dissemination Center for Children with Disabilities (NICHCY) offers a wealth of information on disabilities. They serve as a central source of information on disabilities in infants, toddlers, children and youth. <http://nichcy.org/>

National Down Syndrome Association is the national advocate for the value, acceptance and inclusions for persons with Down syndrome. <http://www.ndss.org/>

Sensory Processing Disorder Foundation (SPDF) provides education, conducts research and expands

knowledge, fosters awareness and promotes the recognition of sensory processing disorder.

<http://www.sinetwork.org/>

Spina Bifida Association (SBA) serves adults and children who live with the challenges of Spina Bifida. SBA is a health agency solely dedicated to enhancing the lives of those with spina bifida and those whose lives are touched by this challenging birth defect. Its tools are education, advocacy, research, and service. <http://www.spinabifidaassociation.org>

WHERE TO FIND ADDITIONAL RESOURCES

Carol Torgan's list of greatest play resources - lists of play resource that include organizations, resources, guidelines and reports, current news stories, books, audio and video, e-newsletters, blogs, twitter hashtags, image and design collections, programs, locations, and events.

<http://www.caroltorgan.com/100-top-play-resources/>

The Play & Playground Encyclopedia - The Play & Playground Encyclopedia is a wonderful resource for play and playground information. Designed to cover a broad range of topics, this encyclopedia offers valuable information about organizations, companies, and people who have contributed to the play and playground industries as well as listings about important issues regarding play, safety, and playground construction.

<http://www.pgpedia.com/>

List of playground equipment grants and fundraising resources - <http://www.playground-contractors.org>



 **PLAYWORLD™**
The world needs play.®