

INDEX

FUEL MIXTURE AND IGNITION TIMING CONTROL	Page	4
WEBER INJECTION-IGNITION SISTEM	Page	4
ELEMENTS MAKING UP THE SYSTEM	Page	4
OPERATION PHASES	Page	15
CARBURATION	Page	15
CHECKING THE FUEL CIRCUIT	Page	18
CHECK LAMP - DIAGNOSIS OF SYSTEM TROUBLES	Page	21
ELECTRONIC IGNITION/INJECTION CABLE ASSEMBLY	Page	25
ELECTRICAL SCHEMATIC	Page	26
SPECIAL SHOP TOOLS	Page	27

INTRODUCTION

Application of an electronically controlled injection-ignition system to 8-cycle engines has made it possible to optimize their performance to give more power with less specific fuel consumption with less unburned fuel in the exhaust. These advantages have been obtained thanks precise regulation of air-fuel mixture and ignition timing.

The illustrations and description in this booklet are indicative only and the manufacturer reserves itself the right to introduce any modification it may deem necessary for better performance or for constructive or commercial reasons without prior notice.

GBM-S.p.a. MOTO GUZZI - SERVIZIO PUBBLICAZIONI TECNICHE
6/89 - 1500 K - COD. 299201 60
Printed in Italy

Revision Notes:

1. Original manual scanned and edited 2/18/01. DJP



MOTO GUZZI

IMPIANTO INIEZIONE-ACCENSIONE ELETTRONICA

DISPOSITIVI ELETTRONICI

- 1 CENTRALINA ELETTRONICA
- 2 MODULI DI POTENZA
- 3 TELERUTTORI
- 4 SENSORE PRESSIONE ASSOLUTA
- 5 SENSORE TEMPERATURA ARIA
- 6 ELETTROINIETTORI
- 7 SENSORE NUMERO GIRI MOTORE
- 8 SENSORE DI FASE
- 9 SENSORE TEMPERATURA OLIO
- 10 BOBINE
- 11 SENSORE RILEVAMENTO APERTURA FARFALLE

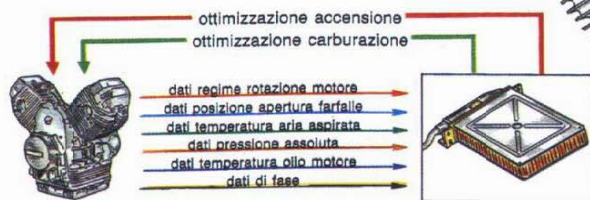
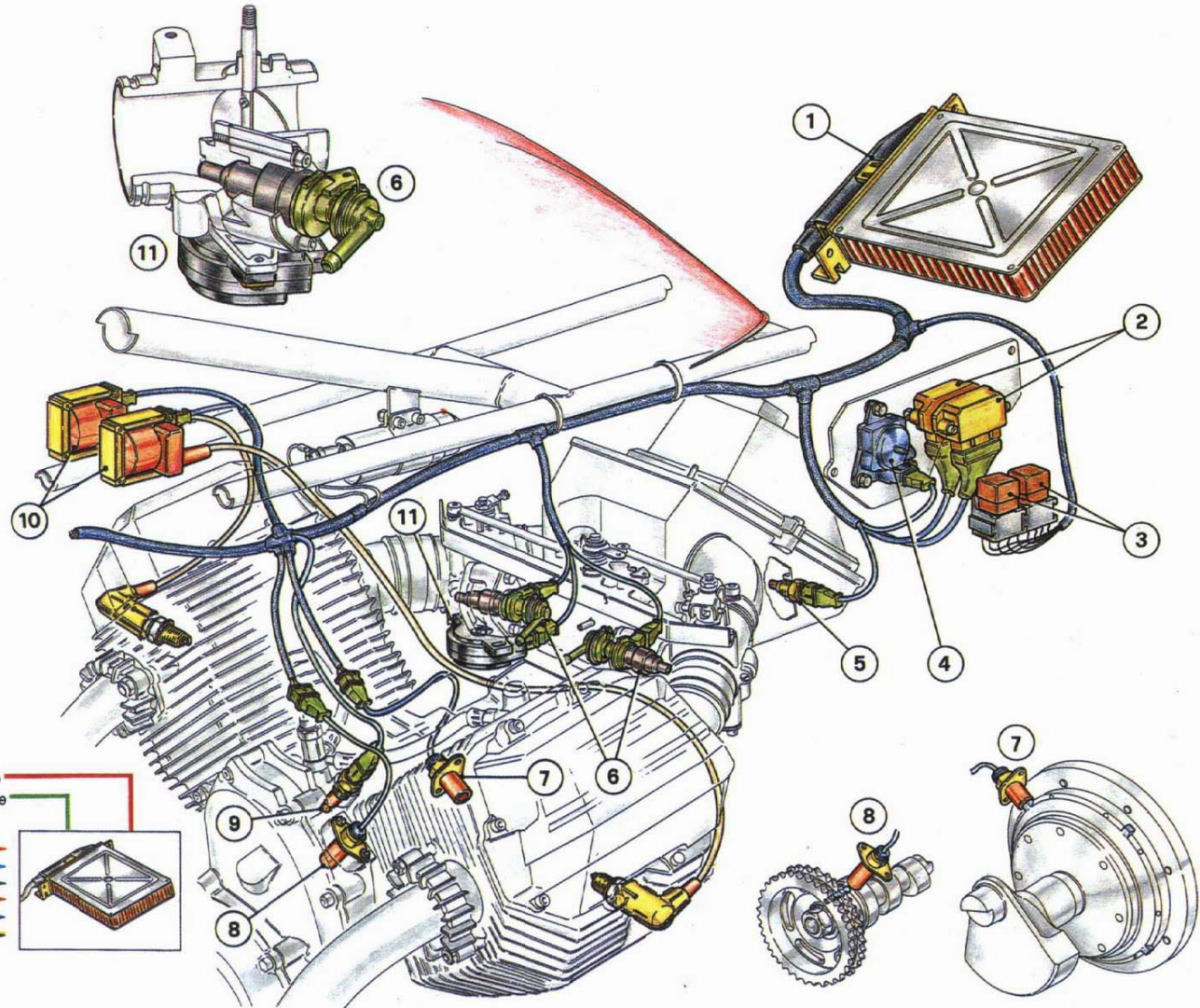



MOTO GUZZI

IMPIANTO INIEZIONE-ACCENSIONE ELETTRONICA

ALIMENTAZIONE

- 1 POMPA CARBURANTE
- 2 FILTRO CARBURANTE
- 3 REGOLATORE DI PRESSIONE CARBURANTE
- 4 ELETTROINIETTORI
- 5 CORPO FARFALLATO
- 6 CONTENITORE FILTRO ARIA

- ← MANDATA CARBURANTE
- ← RITORNO CARBURANTE
- ← CONDOTTO DEPRESSIONE
- ← ASPIRAZIONE ARIA

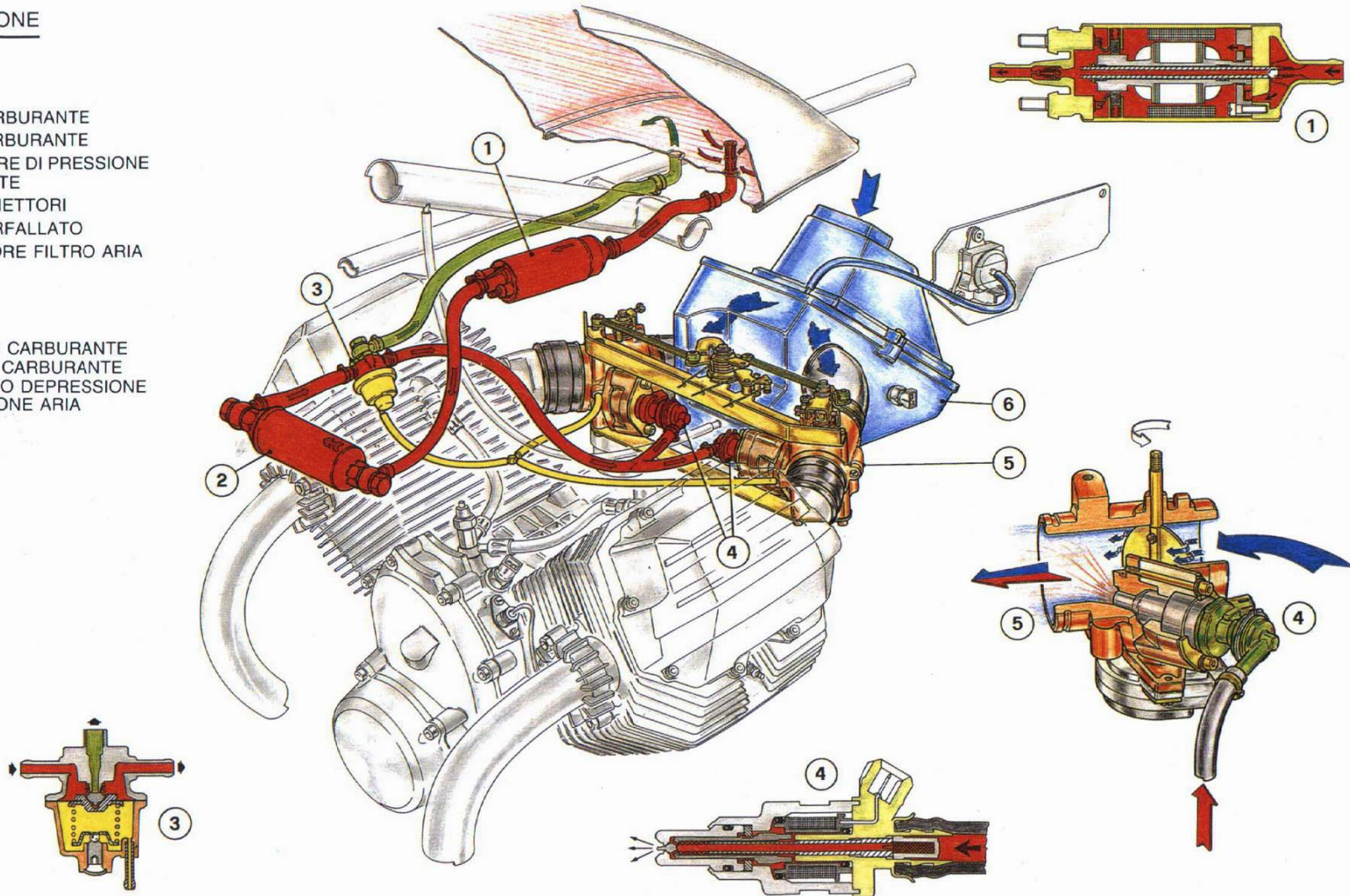

FUEL MIXTURE AND IGNITION TIMING CONTROL

Control of the air-fuel ratio and the ignition timing is the basic element in optimizing engine performance. The air-fuel ratio is given by the ratio, in terms of weight, of air and gasoline drawn in by the engine. The ideal or stoichiometric ratio is that which produces total combustion. Too much or too little air causes respectively lean or rich mixtures which in turn affect power and fuel consumption (see Fig. 1) and exhaust emissions (see Fig. 2). Electronic ignition timing control allows maximizing engine performance and power, and minimizing fuel consumption and emissions. Electronic ignition timing control combined with electronic fuel supply control allows engine performance to be optimized under such varied conditions as low temperature start up, maximum acceleration and normal cruising at partial load.

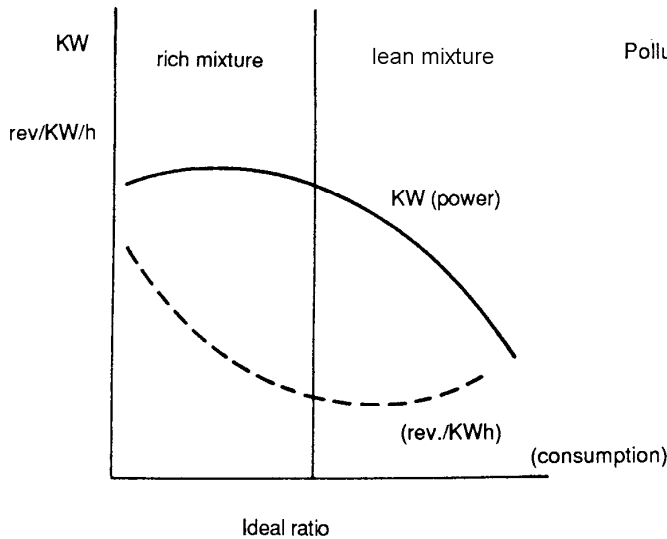

Fig. 1

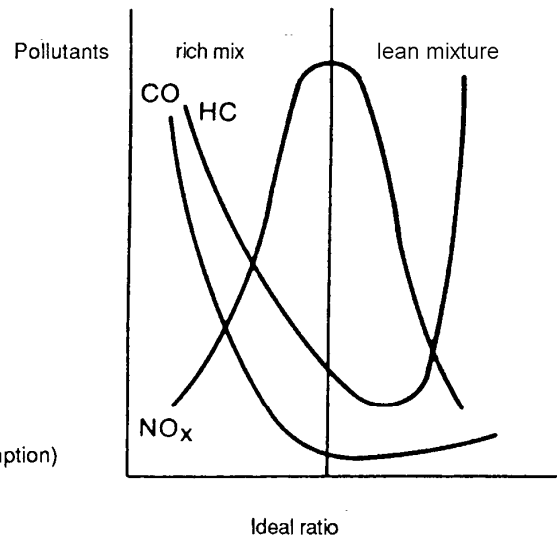

Fig. 2

WEBER INJECTION-IGNITION SYSTEM

The Model Alfa/N Weber injection-ignition system, in which engine speed and throttle valve position are used to measure the amount of aspirated air, notes the amount of air and meters the fuel accordingly. Other sensors within the system allow the base strategy to be changed under special operating conditions. The engine speed and the throttle valve angle allow the optimal ignition advance to be calculated for every operating condition. The amount of air drawn in by each cylinder for each cycle will depend on the air density in the intake air manifold, the unitary displacement and the volumetric efficiency.

Volumetric efficiency is established experimentally on the engine for its entire operational field and this is then programmed in a map in the computer. The injection system is the sequential multi-port type meaning fuel delivery to each cylinder is independent of conditions at the other cylinder. Fuel delivery for one cylinder can occur during the combustion and exhaust phase of the other cylinder. Fuel delivery timing for starting is also in the map in the computer. Ignition is by static induction spark with dwell control in the power module and spark advance curves programmed in the computer.

ELEMENTS MAKING UP THE SYSTEM

Fuel circuit

Fuel is injected into the intake passage for each cylinder upstream of the intake valve. The circuit consists of a tank, pump, filter, pressure regulator valve and electromagnetic injectors.

Intake air circuit

This consists of an air filter, intake manifold and throttle valve. The throttle position sensor (TPS) is a potentiometer mounted on the bottom of the throttle butterfly valve stem. The barometric pressure sensor and the air temperature sensor are positioned upstream of the throttle valve.

Electric circuit

This is the circuit used by the computer to adjust the fuel supply and ignition timing to provide optimum performance and reduced emissions under a variety of operating conditions. It includes: a battery, ignition switch, two relays, the computer, the ignition assembly, barometric pressure sensor, air temperature sensor, throttle position potentiometer, two injectors, oil temperature sensor, rpm and timing sensors.

Schema a blocchi di funzionamento
Block chart for system operation

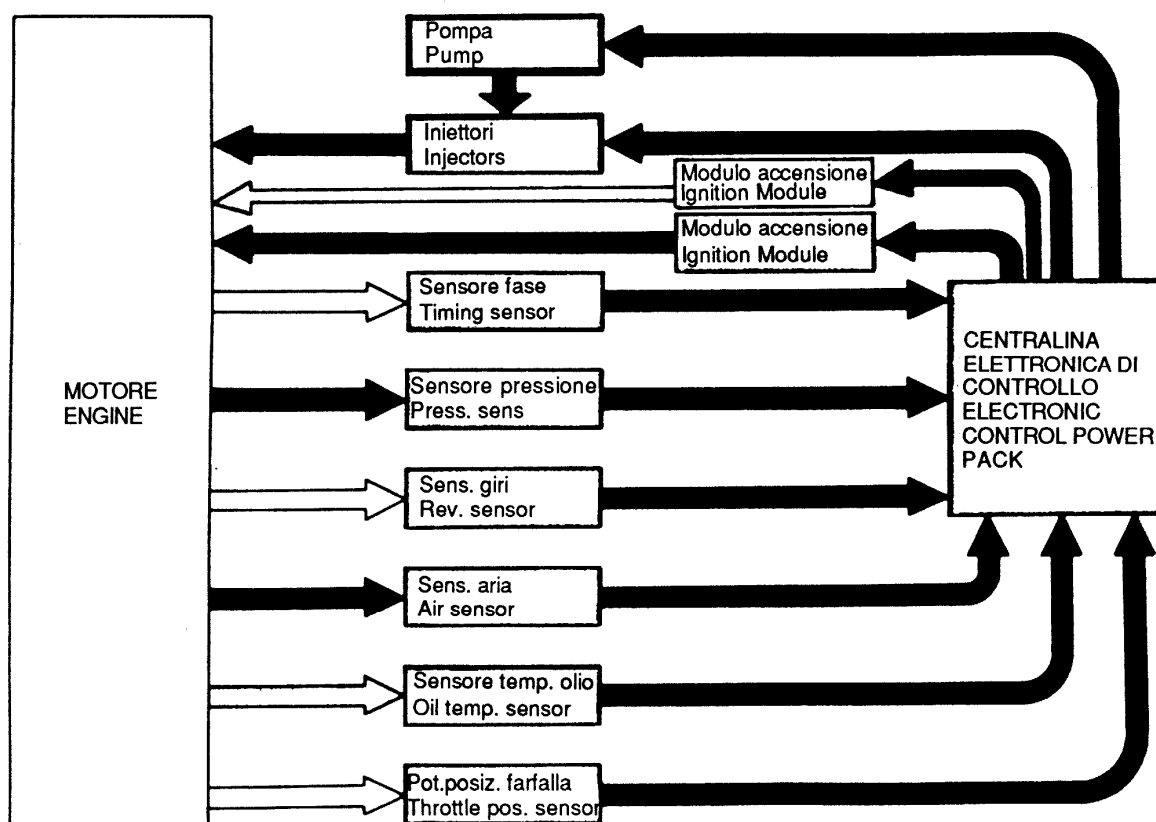

FUEL CIRCUIT

The electric pump draws fuel from the tank and sends it through a filter to a manifold equipped with feed branches to the injectors. A pressure regulating valve maintains steady fuel pressure by bleeding excess fuel back into the tank.

Electric fuel pump

This is a roller positive displacement pump with the motor submerged in the fuel. The motor is a permanent magnet carbon brush type. When the impeller is turned by the motor, the fuel is moved from the intake orifice to the delivery port. The amount of fuel is determined by the rollers which adhere to the outer ring while the motor is turning. The pump has a check valve to prevent the fuel circuit emptying when the pump is not running. It is also equipped with an overpressure valve which short-circuits the delivery when the pressure is over 74 psi to prevent the pump motor from overheating.

Delivery: 26.5 gal/hour at 44 psi with 12V power supply. The pump draws about 4.5 amps.

Note: We recommend strict cleanliness whenever the hoses are installed or removed, or when work is done on the system.

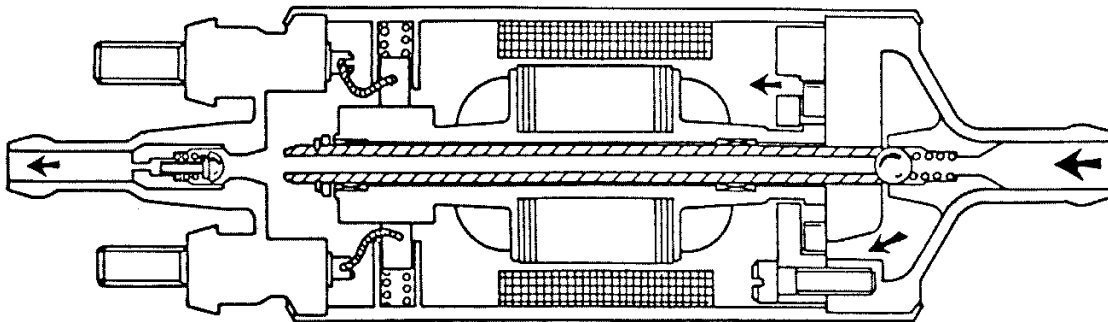
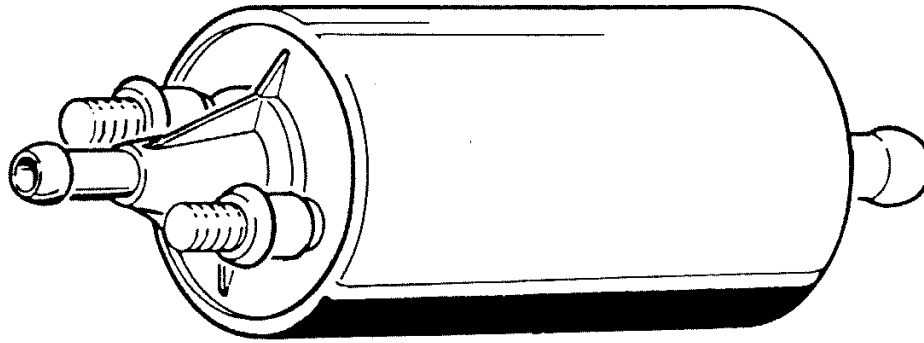

Fuel filter

This filter has a 10 μm . paper element with a filtering surface of 1200 cm^2 . This filter is essential because the injectors are easily clogged by contaminants. The filter is mounted between the pump and the pressure regulating valve. An arrow in the casing indicates flow direction. The filter should be changed every 6,200 miles.

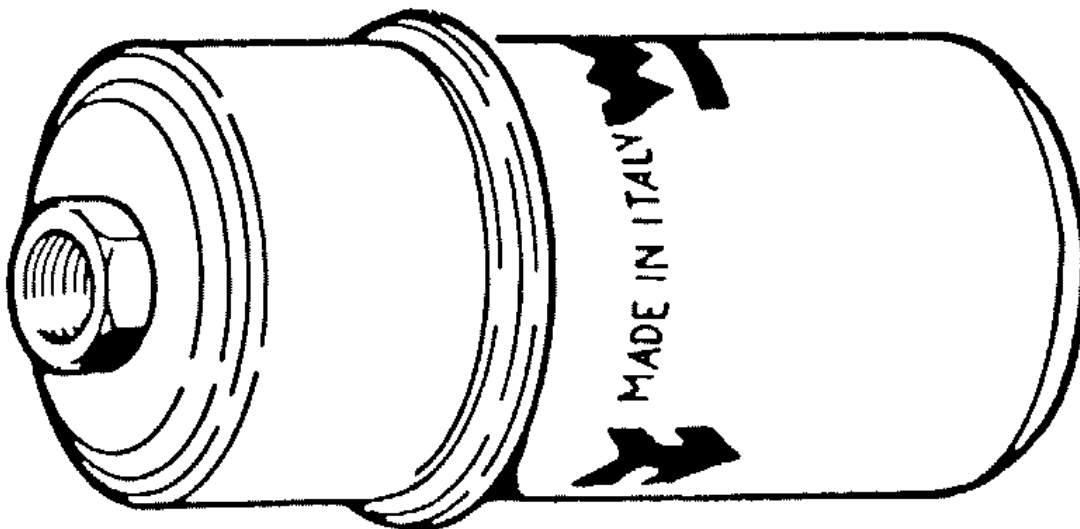

Injectors

The injectors control the amount of fuel delivered to the engine. The injector is an ON-OFF valve. It has just two operating modes, open or closed.

The injector consists of a shell and a pin forming part of the magnetic armature. This pin is pressed up against its seat by a spiral spring whose load is determined by an adjustable push ring. The winding is

housed in the rear part of the casing while the injector nose is at the front (seal seating and pin guide). The control impulses from the computer create a magnetic field which attracts the armature and thus opens the injector. The amount of fuel injected depends solely on the amount of time the injector is open, assuming constant fuel viscosity and density, and constant pressure differential. This time is established by the computer depending on the engine's operating environment.

When the fuel pressure is in the range of 34-40 psi, the jet breaks into a spray as soon as it leaves the nozzle and forms an arc of approximately 30°.

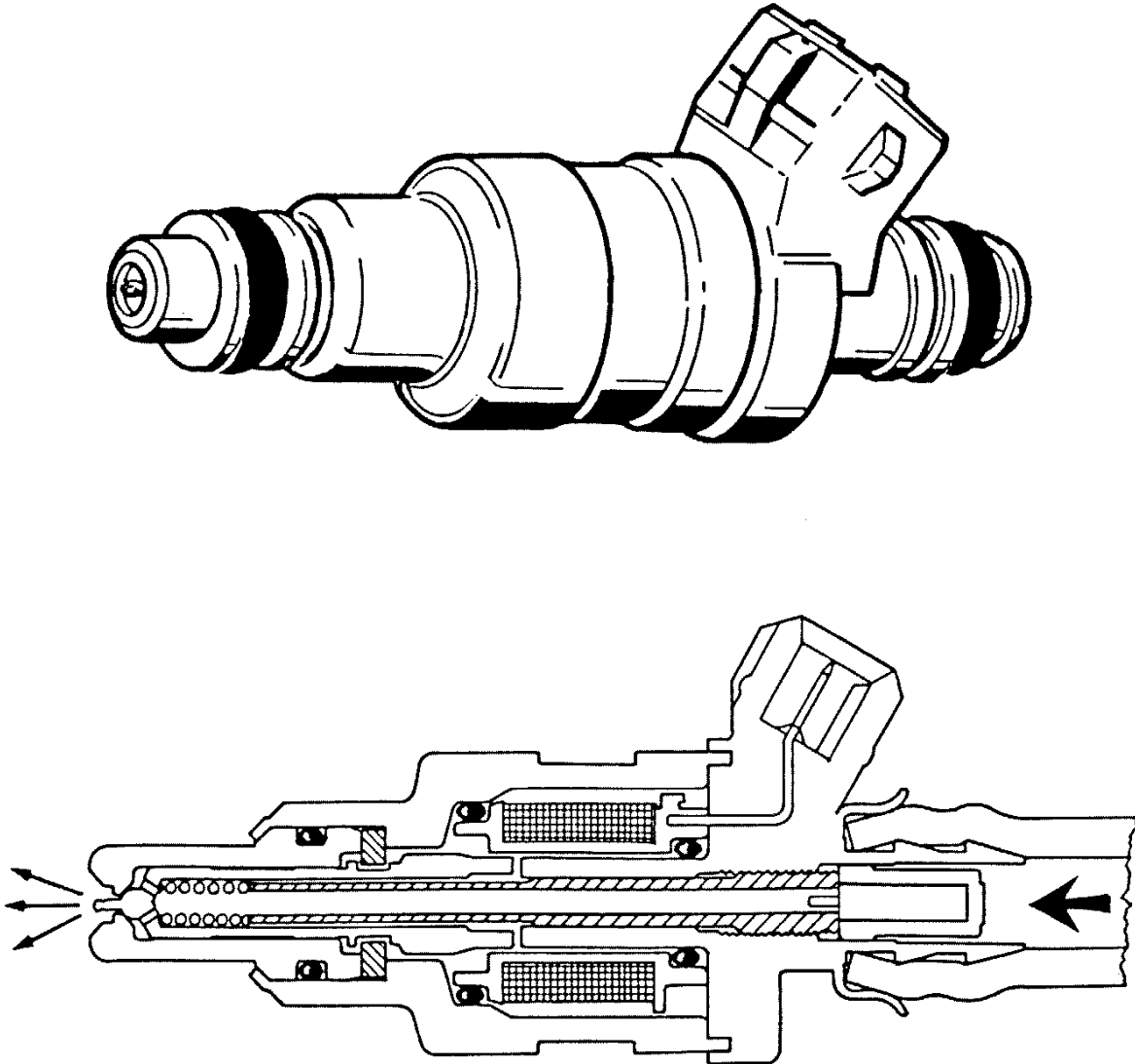

Resistance value: 12Ω.

If you want to test the injector electrically, apply a maximum of 6 volts for an extremely short period of time.

Pressure relief valve

This valve maintains steady pressure to the injectors. It is a differential membrane type and is factory set at 36.8 ± 3 psi. The pressurized fuel from the pump exerts pressure against the mobile part (1) which is countered by the calibrated spring (3). When the set pressure is exceeded, the valve cup moves (2) and the excess fuel flows back into the tank.

Note that to keep the injector pressure stage steady, the difference between fuel pressure and intake manifold pressure must also be constant. This is achieved by running a tube between the seating of the calibrated governor spring (3) and the intake manifold.

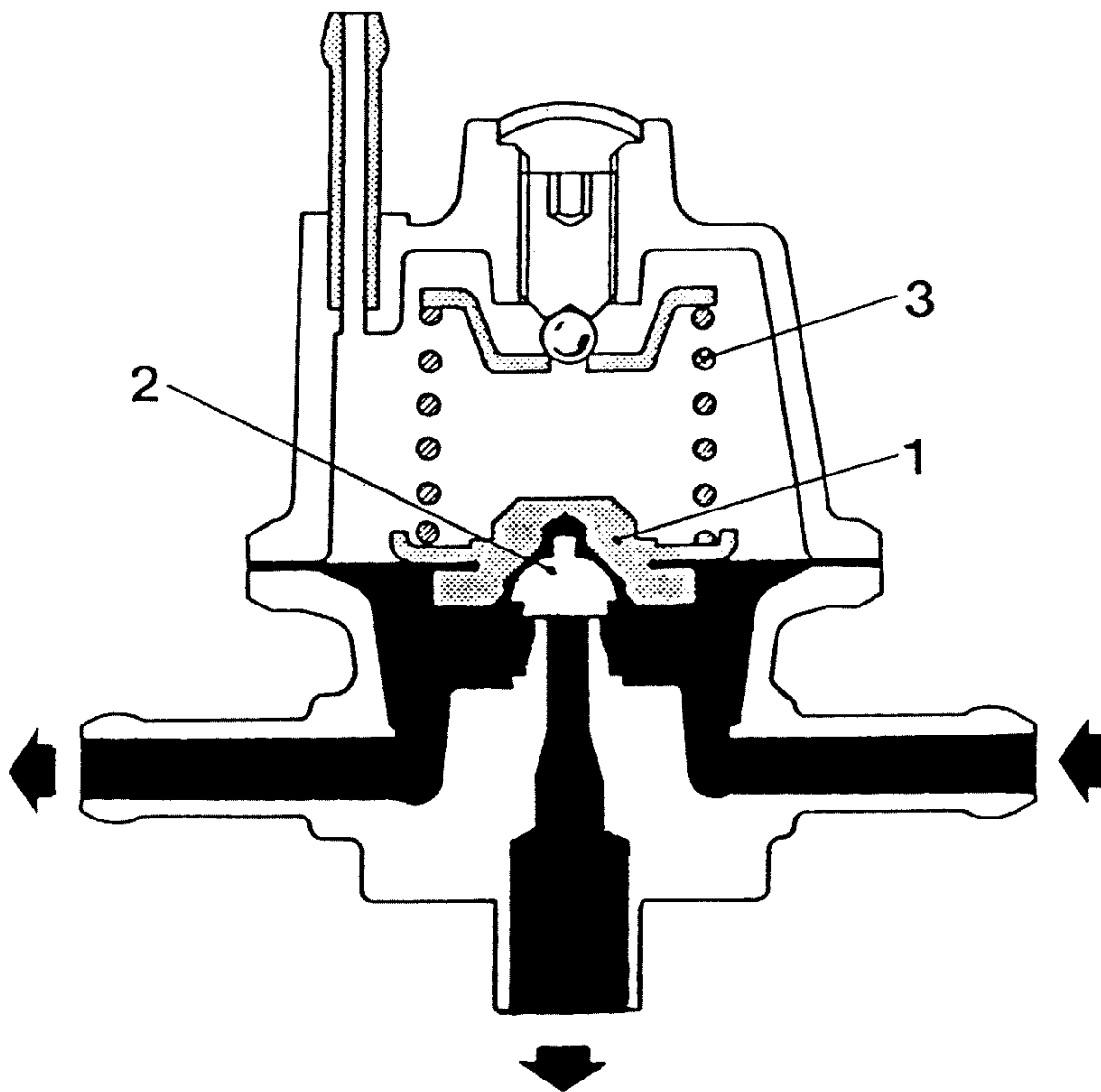

- 1) Mobile element
- 2) Cup valve
- 3) Calibrated counter-spring

AIR CIRCUIT

The air circuit is made up of the throttle valve and the air filter assembly. The barometric pressure and air temperature sensors measure conditions in the filter. [The temperature sensor is mounted on the frame in front of the air snorkel on a Cal 1100i] The fuel pressure relief valve measures conditions in the intake manifold. The throttle position reading potentiometer is on the butterfly stem of the throttle valve.

Intake manifold and throttle valve

The amount of air intake is determined by the opening of the butterfly valve (1) in the intake air manifold on each cylinder. The air needed for idling goes through the by-pass channel (2) which has an air adjusting screw (3). Turning this screw varies the amount of air admitted to the manifold to adjust the idle speed. A second screw (4) with a locking nut allows the butterfly valve closing to be adjusted correctly to prevent it hitting up against the surrounding manifold. This screw should not be used to adjust the idle setting.

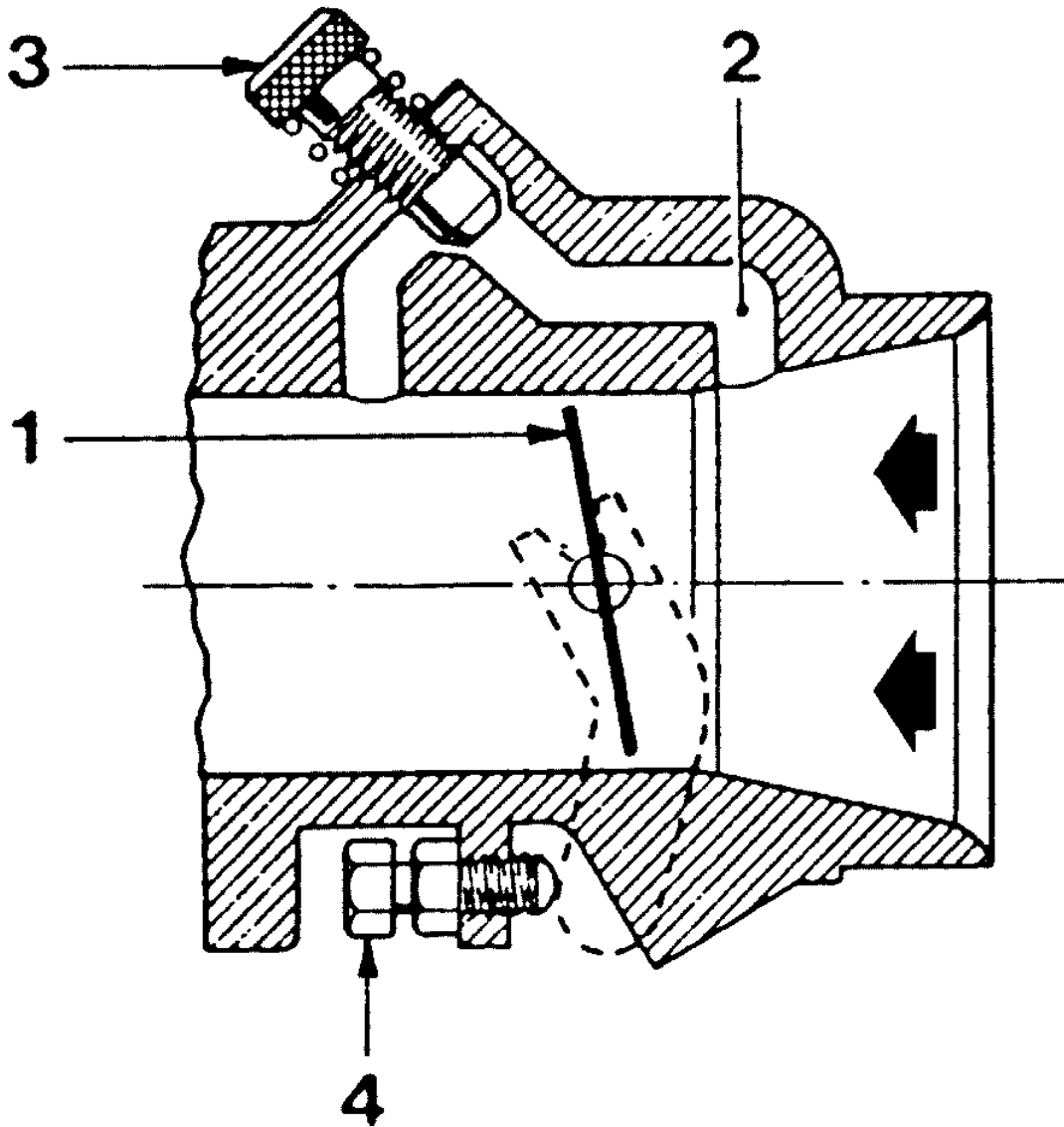

- 1) Throttle valve
- 2) By-pass passage
- 3) Air regulation screw
- 4) Butterfly positioning screw

ELECTRIC CIRCUIT

Relays

The Weber injection-ignition system uses two socket mounted automotive relays. [The stock Siemens V23073 relays are trouble prone. Suitable substitutes are Siemens V23074, Bosch 0-332-207-307, Radio Shack 900-2391] The grounding connection of the relay energizing circuit is done in the power pack with a guard to prevent inverting the polarities. These two relays control:

- fuel pump power supply
- computer and injector power supply

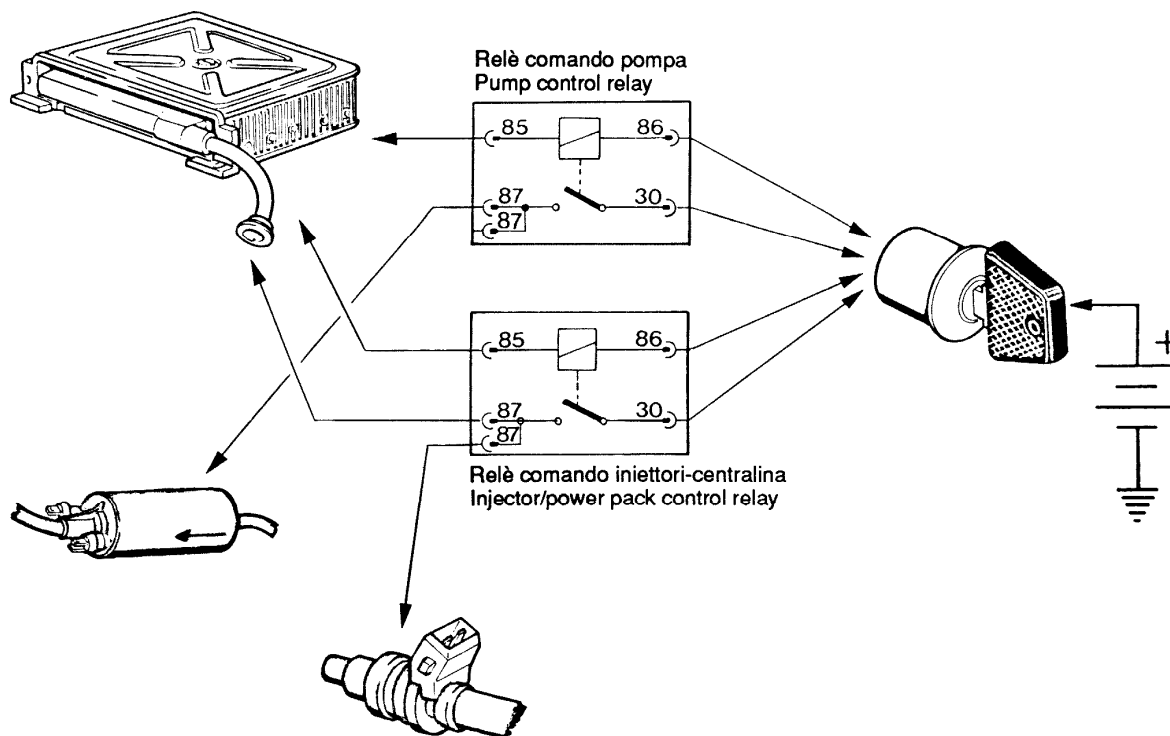

WEBER injection-ignition computer

The Weber injection-ignition computer is an electronic digital microprocessor control unit. It controls the parameters for the fuel supply and ignition:

- amount of fuel delivered to each cylinder
- injection timing
- ignition advance

To calculate these parameters, the unit uses the following input signals:

- barometric pressure
- intake air temperature
- oil temperature
- engine speed and timing
- battery voltage
- throttle valve position

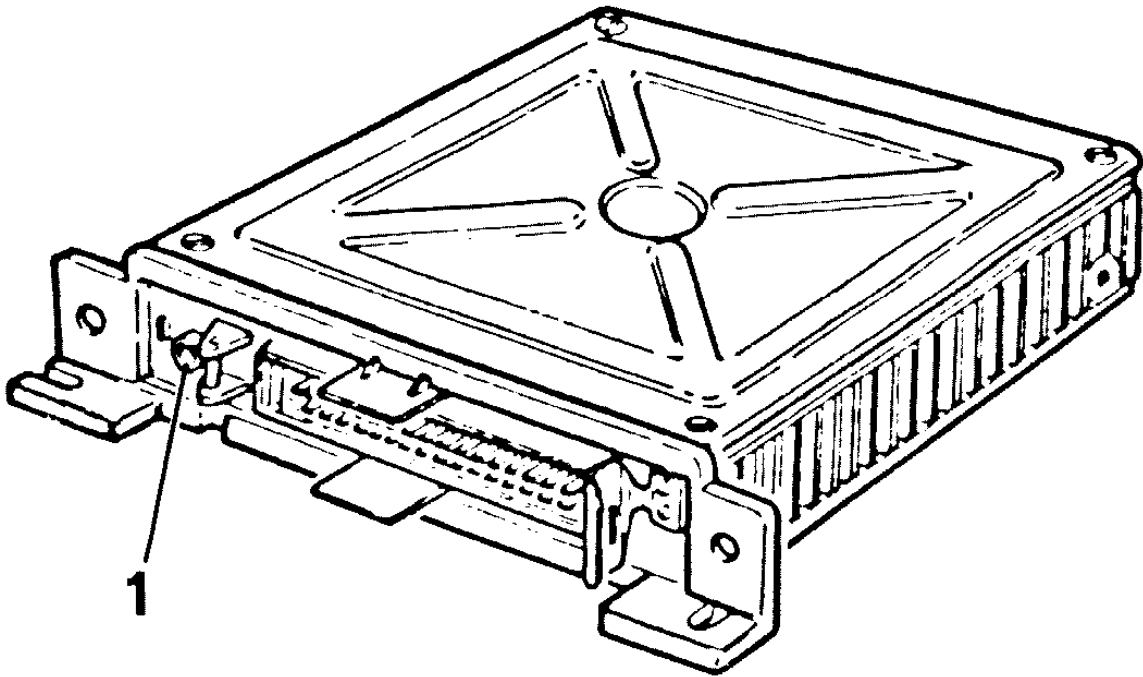

1) CO regulation protection cap to prevent tampering

Barometric pressure sensor

The sensor is supplied with power by the computer and measures the air pressure in the air filter.

OUTPUT SIGNAL CHARACTERISTICS

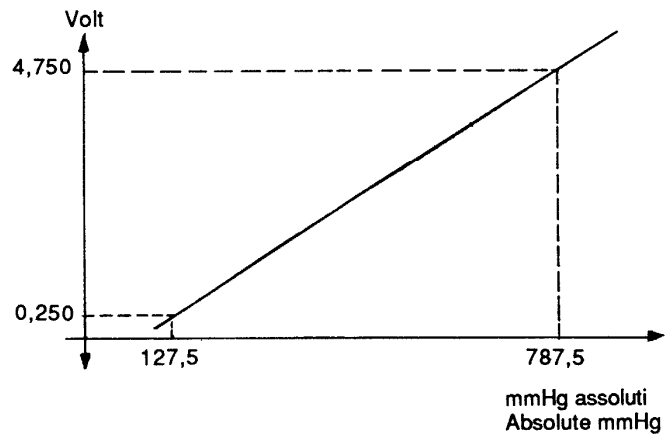
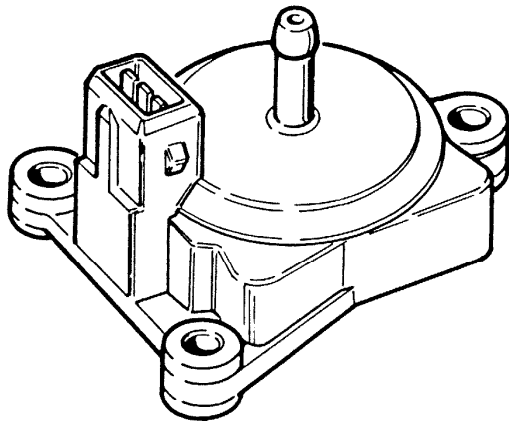

Air temperature sensor

This sensor is an NTC thermistor that measures air temperature in the air filter and sends a signal to the computer. Excessive torque on the mounting screws will damage it.

Note: NTC means that the thermistor resistance decreases as the temperature increases (see table).

Oil temperature sensor

This sensor is an NTC thermistor that measures oil temperature in the valve cover and sends a signal to the computer. Excessive torque on the mounting screws will damage it. Replace the mounting gasket whenever this sensor is removed.

Note: NTC means that the thermistor resistance decreases as the temperature increases (see table).

Note: Resistance values are identical for both air and oil temperature sensors.

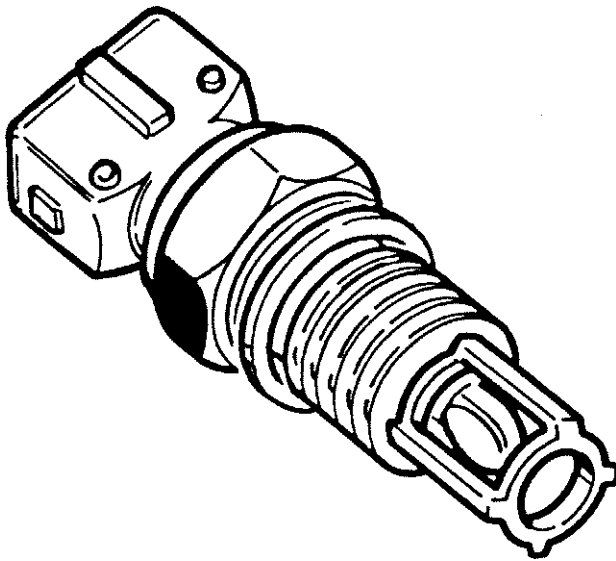

Electrical symbol		
Theoretical data		
Temperature		Resistance Kohm
C°	F°	
-40	-40	100.950
-30	-22	53.100
-20	-4	29.121
-10	14	16.599
0	32	9.750
10	50	5.970
20	68	3.747
25	77	3.000
30	86	2.417
40	104	1.598
50	122	1.080
60	140	0.746
70	158	0.526
80	176	0.377
90	194	0.275
100	212	0.204
110	230	0.153
125	257	0.102

Motor RPM sensor

This is a variable reluctance sensor. It is mounted on the bell housing facing the flywheel assembly. The flywheel has 4 detector teeth set at 90° to each other. As each tooth passes, the sensor sends an AC signal (see diagram.). The frequency of this signal generates the information on the engine speed.

PMS (TDC) sensor

This is also a variable reluctance sensor. It is mounted on the timing case, senses cam shaft rotation and generates the information needed to know the position of the cylinders in relation to their combustion top dead center.

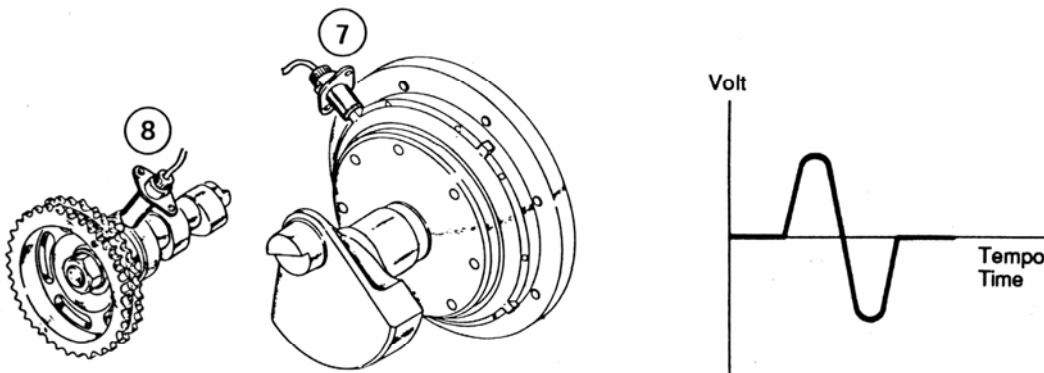
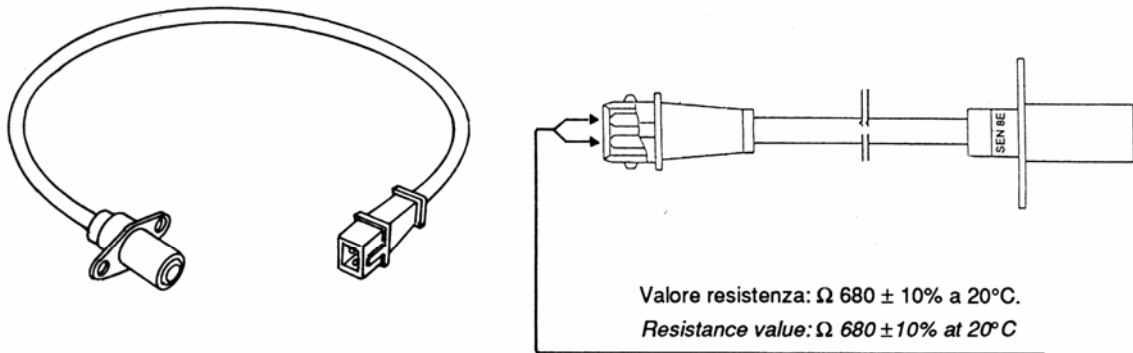

7) Sensore numero giri motore
8) Sensore di fase

7) rpm sensor
8) Timing sensor

TRAFERRO SENSORE NUMERO DI GIRI E SENSORE DI FASE AIR GAP: RPM SENSOR AND TIMING SENSOR

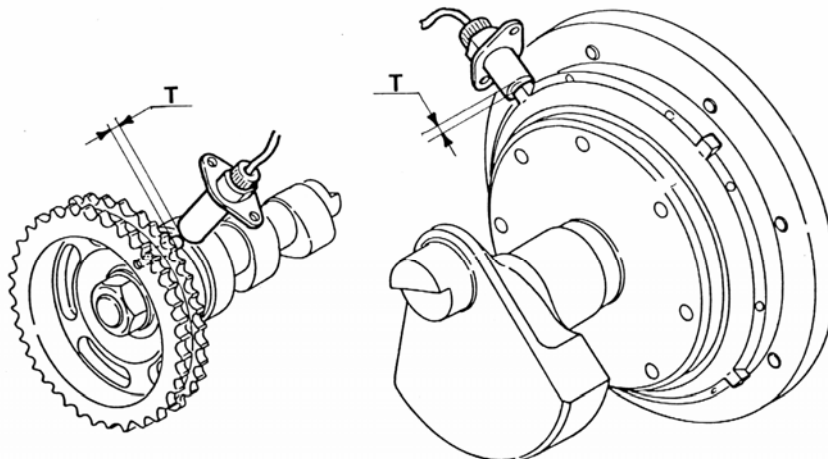

Traferro T mm. 0,6+1,2

Air gap T . 0,6+1,2 mm

Coil with power module

The ignition is inductive spark. The coil power module unit receives its commands from the computer which determines the ignition advance. The power module (1) also insures that the coil (2) receives constant energy charge.

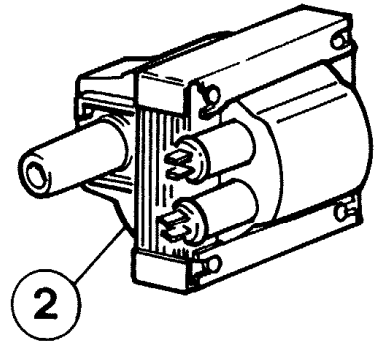
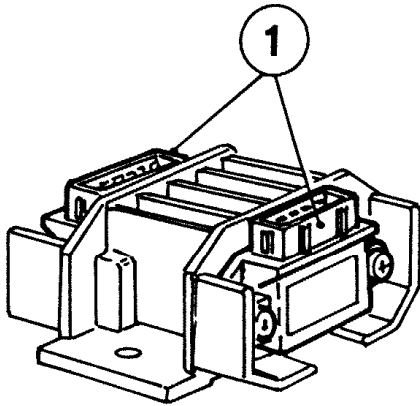

- 1) Power module
- 2) Coil

Throttle position potentiometer (TPS)

This potentiometer is supplied with power from the computer to which it sends a signal denoting the throttle position. This information is used to adjust fuel metering during starting, idling, acceleration, cruise, and deceleration.

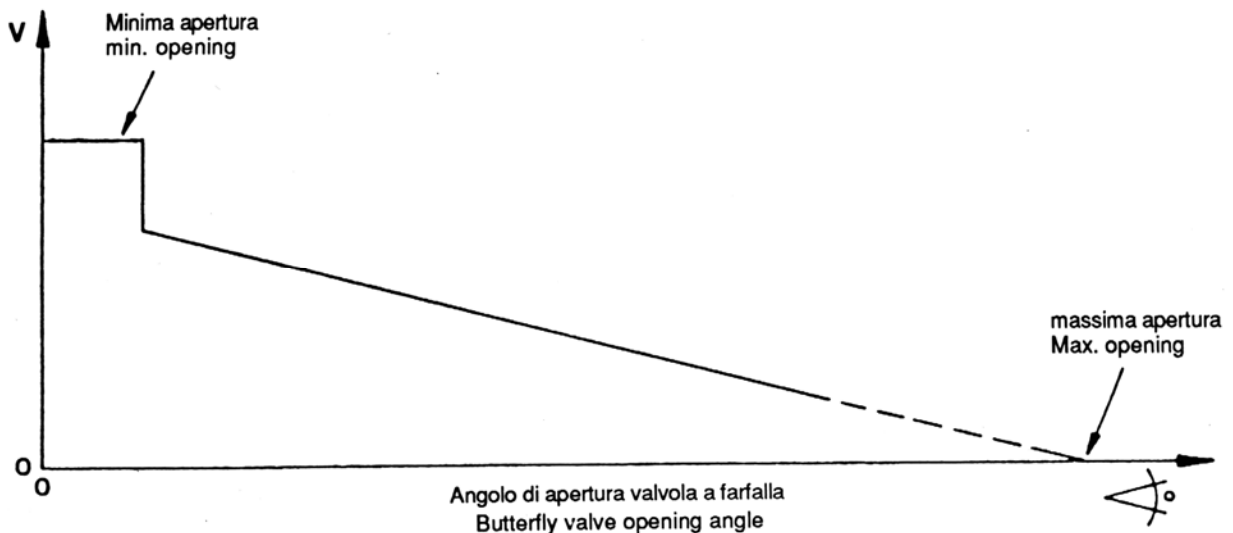
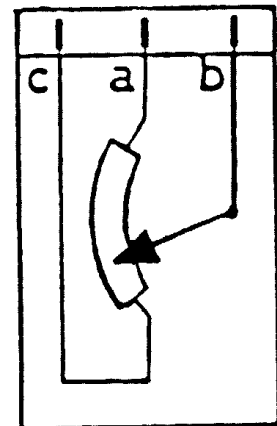
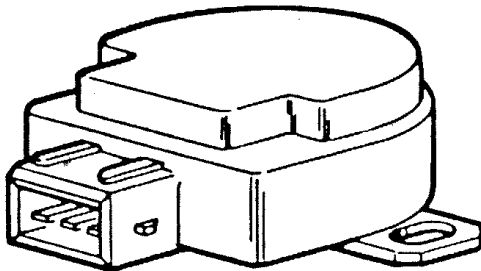

This diagram shows the transmission signal sent by the sensor depending on the throttle opening angle.

OPERATION PHASES

Normal operation

When the engine is at operating temperature, the computer calculates the timing, the injection timing and duration and the ignition advance by interpolating the programmed maps according to the engine speed. The injection duration (and therefore the amount of fuel) so calculated is then delivered sequentially to each cylinder. The moment when this fuel begins to be delivered to each cylinder is similarly determined according to engine speed.

Starting phase

As soon as the starter switch is pressed, the computer powers the fuel pump for a few seconds and determines the throttle angle and engine oil temperature. The computer next receives data on the rpm and the timing which allows it to control the injection and ignition. To facilitate starting, the base mix is enriched in accordance with the temperature of the oil. While the engine is being turned over, the ignition advance is fixed (0°) until the engine has started. Once the engine has started, the ignition timing is controlled by the computer.

Acceleration

The system increase the rate of fuel delivery during acceleration to improve drivability. Acceleration is detected by a significant change in throttle position angle. The amount of enrichment is also dependant on the oil and air temperatures.

Deceleration

When the throttle is closed while the engine is working at high level, the fuel supply is cut off for a period. This increases engine braking and reduces fuel consumption and emissions. Deceleration is detected by both throttle position and engine speed.

CARBURATION

Before adjusting the carburation, if potentiometer "A" (TPS) has been replaced, removed or is out of adjustment, the first thing to be done is to adjust it. Follow these steps:

Potentiometer adjustment

- disconnect tie-rods "B" and "C" from the throttle valves;
- slacken screw "D" (butterfly positioning) until the extremity of the beat has been removed away from it;
- remove the potentiometer's holding screw "E"
- check to make sure that the valve flap closes the passage completely;
- turn and release the casing of potentiometer "A": the internal spring will then position the potentiometer correctly;
- screw down the potentiometer and make sure it does not move while the holding screw "E" and the washers are being put back.

[Note: The above procedure is no longer valid. Revised procedure is as follows:

- disconnect tie-rod "C" from the right side throttle valve;
- Back out screw "D" (butterfly positioning) until it is no longer effective;
- loosen the potentiometer's (TPS) holding screws "E" just enough to allow snug rotation;
- check to make sure that the valve flap closes the passage completely;
- connect the negative lead of a digital voltmeter to terminal 17 at the computer or the white wire at the TPS. Connect the positive lead of the meter to terminal 11 of the computer or the red-black wire at the TPS. Turn on the ignition (do not start engine). Rotate the TPS assembly until a reading of 135-165 mv is measured on the meter ;
- Tighten the TPS mounting screws. Check that voltage is still 135-165 mv and repeat as necessary.]

Adjusting the idle

- Warm up the engine;
- disconnect tie-rods "B" and "C"; attach vacuum gauges to the intake manifold of each cylinder;
- close the by-pass screws "M", and with the engine running, adjust the engine speed using screws D and F until you get 800 rpm (use a precision tach). Check to make sure that the vacuum value on both manifolds is the same.
- Check that the CO value is around 3%;
- Adjust the two by-pass screws "M" until you get an operating level of 900 - 1000 rpm with the same vacuum in each manifold;
- mount the "B" tie-rod on the right cylinder throttle control lever (first slacken off screw "G" to prevent

interference from lever "H");

- mount tie-rod "C", on the left cylinder throttle control lever. To do this turn screw "I" so that the end of tie-rod "C" is perfectly inserted into the pin on lever "L" but without having to move this lever;
- bring the engine to 1500 rpm with the throttle and check the vacuum on both manifolds. If you have to adjust, use the throttle synchronizing screw "I";
- release the throttle and recheck the vacuum in both manifolds (they should be the same);
- replace the anti-tampering plastic caps on the regulating screws for the throttles and by-pass ("F", "B", "M");
- use the exhaust gas analyzer to check the CO which should be 2.5-3.5%. If this is not the case, carefully remove plug "N" from the front of the computer and with a 4 mm wide screwdriver adjust the trimmer screw to achieve 2.5-3.5% CO. Turning the screw clockwise leans the idle mixture. This adjustment changes only the idle mixture.

Note: Do not force the adjusting screw beyond its limit stop (it can make a max. of about 3 turns)

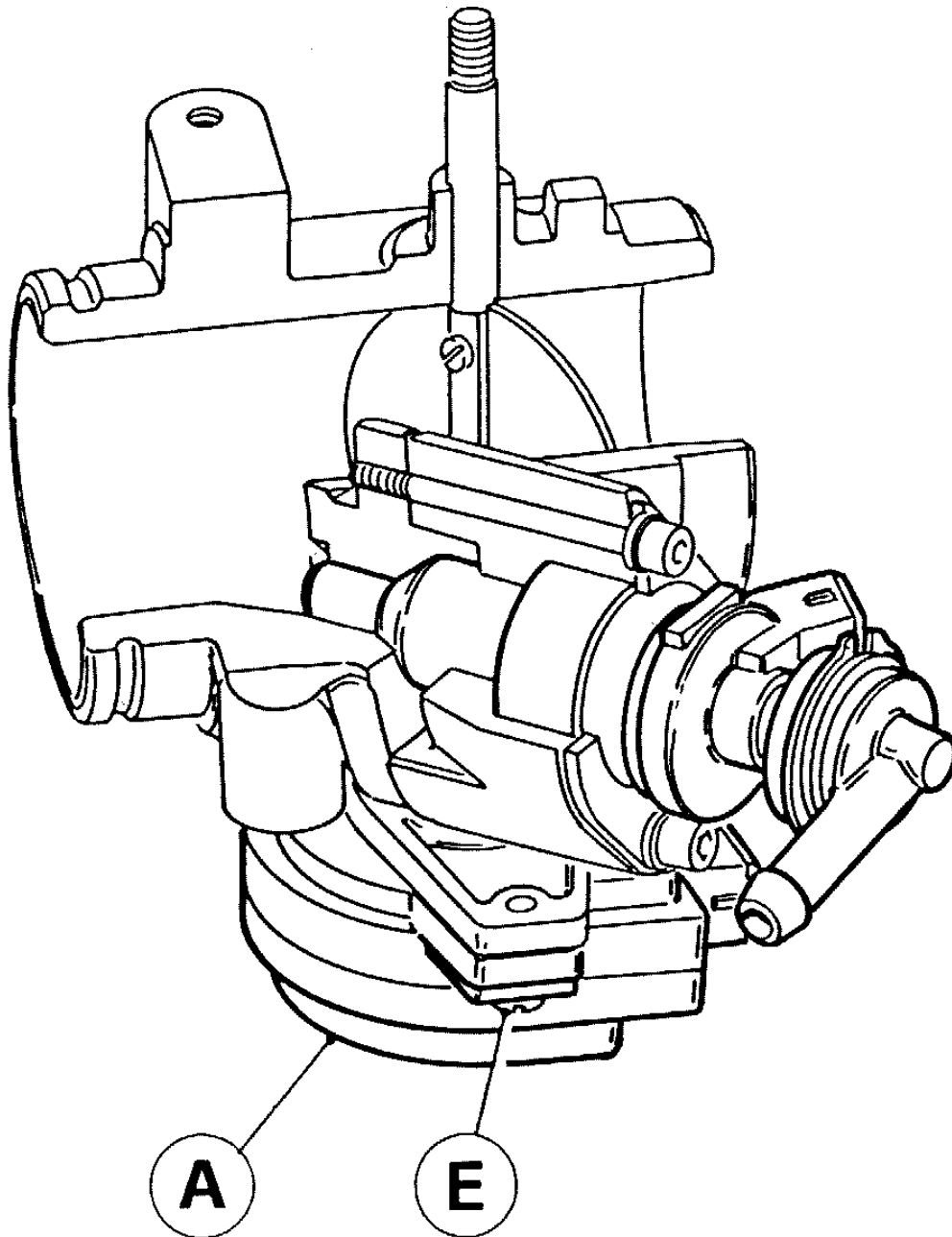

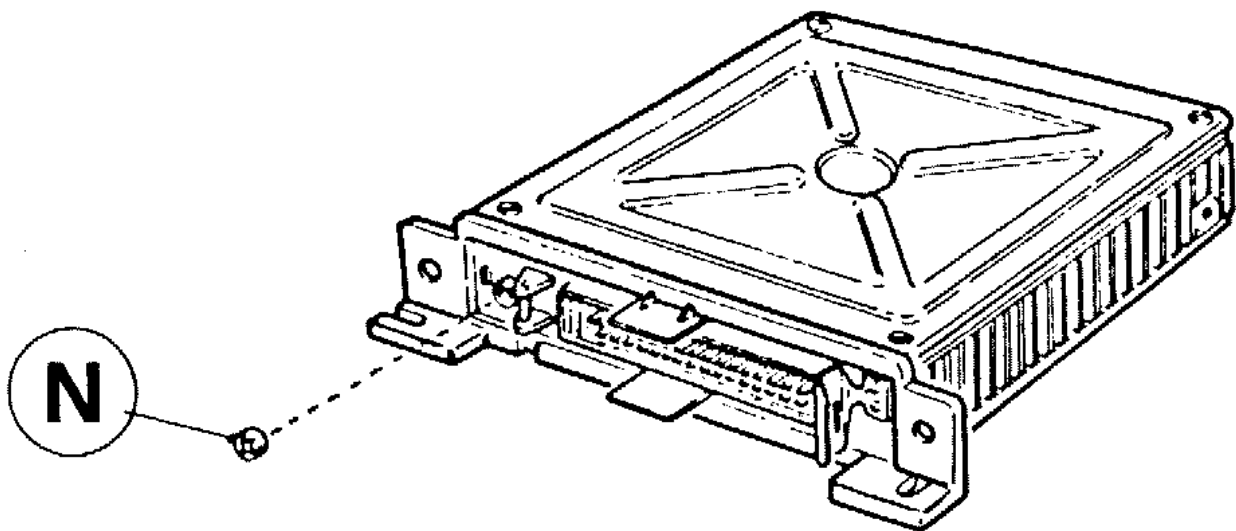
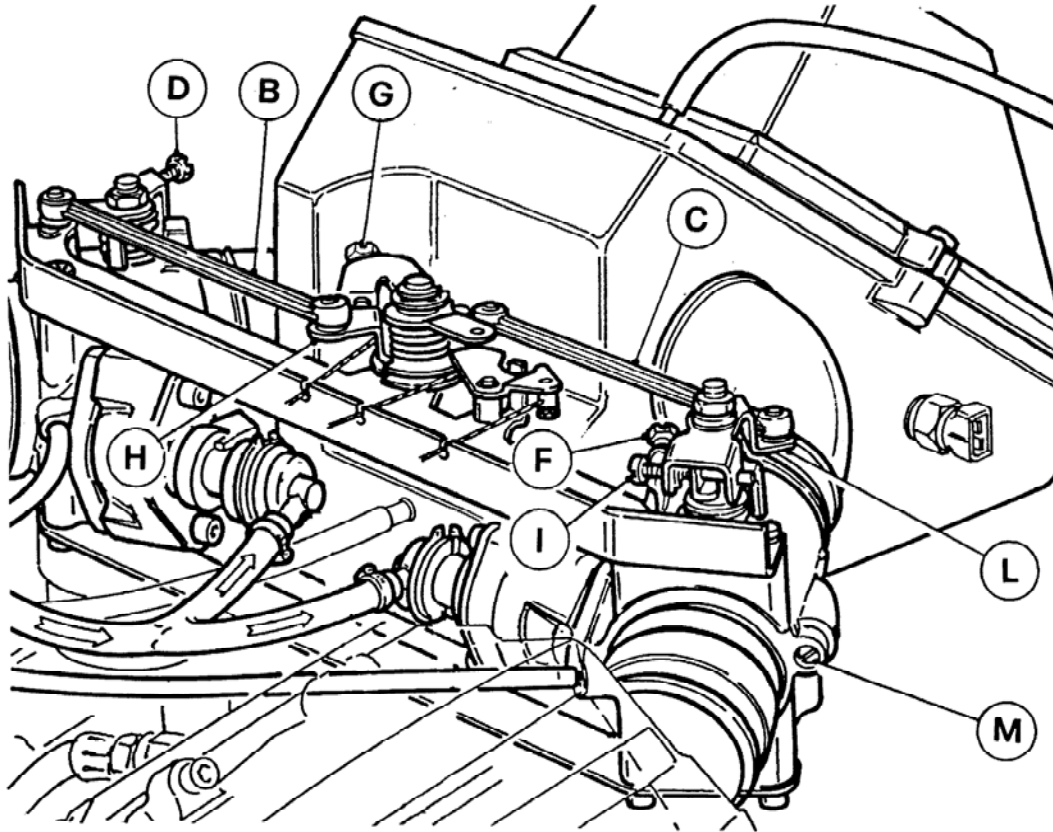

Adjusting choke RPM

Make sure the idle speed is correct. With the engine hot, apply full choke. Set the engine speed to 4500 rpm using screw "G." When the choke is completely disengaged, screw "G" should not contact the accelerator control tie rods.

[Note: The term "choke" here is incorrect. The choke lever merely opens the throttle butterfly valves slightly. It does not enrich the mixture by restricting the air flow or by any other means.]

IMPORTANT:

Always observe the following precautions to prevent damage to the system:

- Insure that the ignition switch is in the OFF position before disconnecting the battery.
- Do not disconnect the battery with the engine running. Make sure the battery cables are in good working condition.
- Do not use an arc welder on the motorcycle.
- Do not use auxiliary electrical equipment to start.
- If you mount anti-theft or any other electric devices on the bike, make sure that they do not interfere with the electronic ignition/injection system in any way.

The air/fuel ratio can not be changed with this electronic ignition/injection system.

Apply di-electric grease to all electrical contacts to avoid oxidation.

CHECKING THE FUEL CIRCUIT

Prepare the motorcycle as follows:

- remove the adapter which attaches the fuel delivery pipe from the pump and insert a gauge to check circuit pressure (Fig. A);
- turn the ignition key to "ON" but do not start the engine (this energizes the fuel pump for about 5 seconds). While the pump is running, pressure should be 34-40 psi. (Fig. A). When the pump stops running, the pressure will go down and stabilize at a pressure below 37 psi.

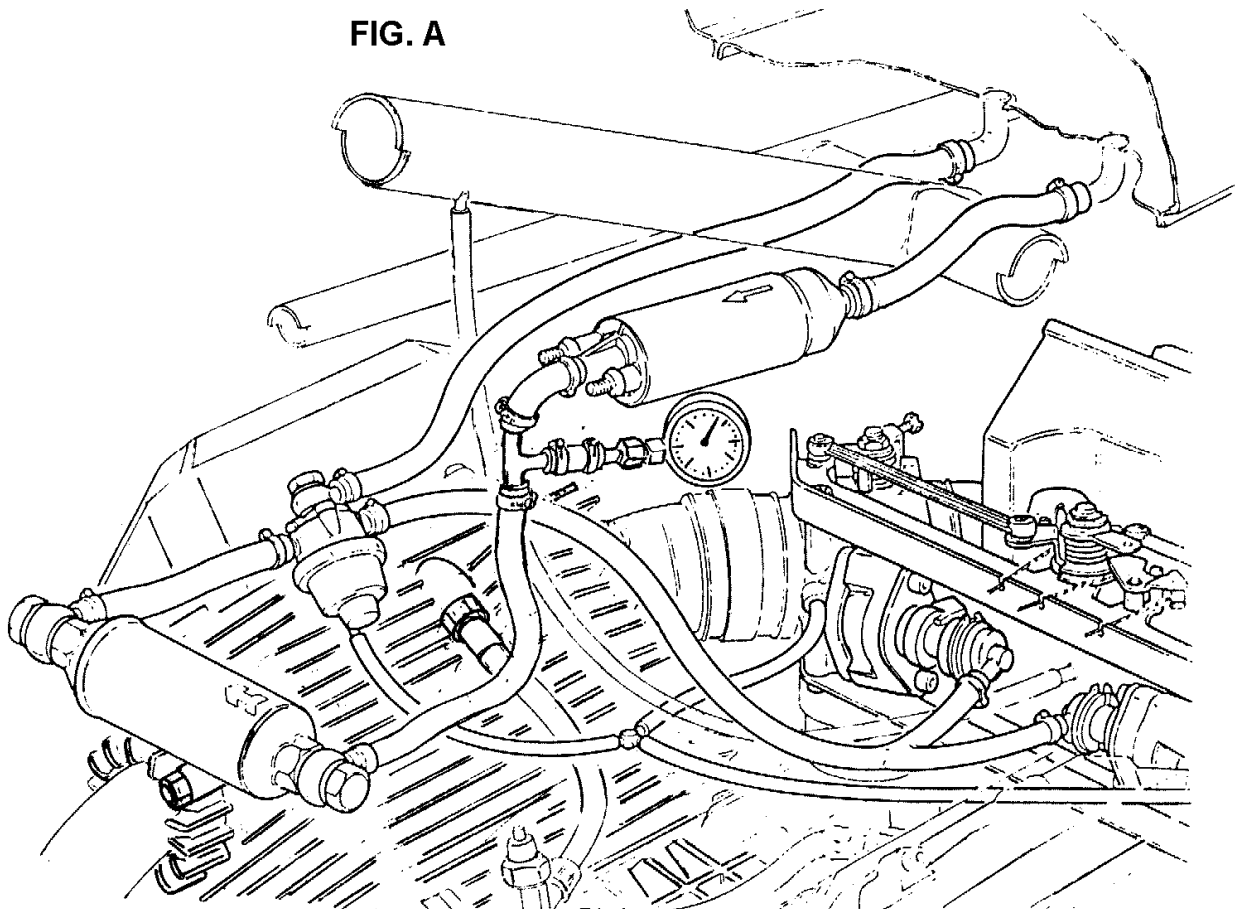

Pressure should remain steady at that value for a few minutes. If the pressure shown on the gauge drops in a short time, do the following:

- turn the ignition key to "ON" and while the pump is running, close the pipe at position "1" using snappliers (use protective pads on each jaw so as not to damage the tube, Fig. B.). The pressure shown on the gauge will be 34-40 psi. and should remain steady. If this happens, it means that the drop in pressure was caused by imperfect seal on the fuel pump check valve.

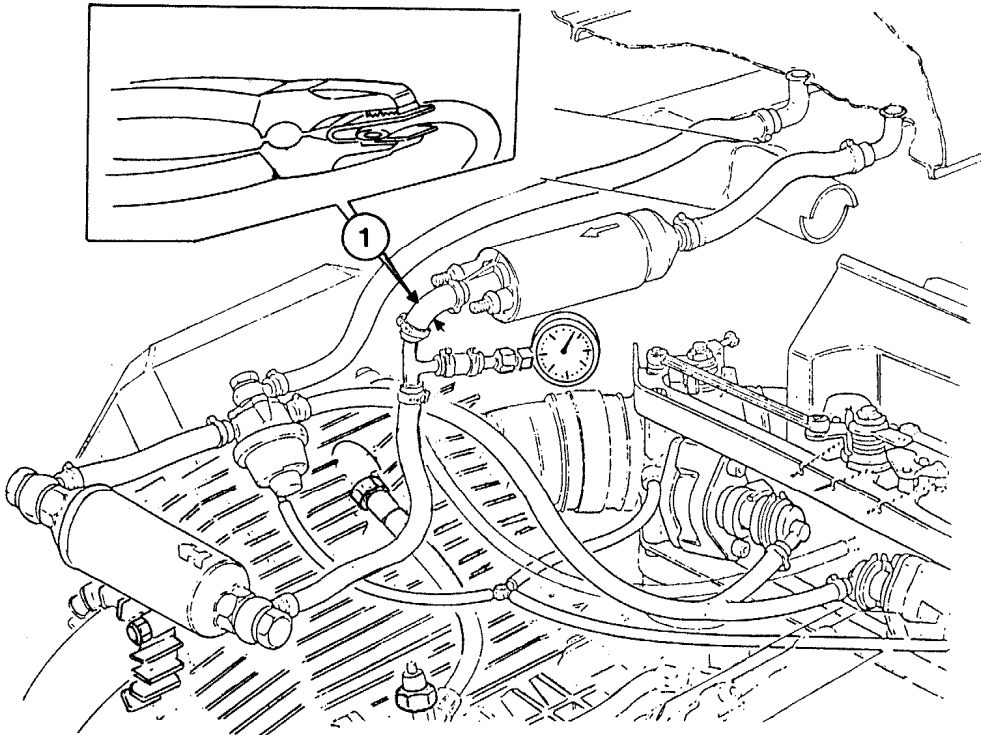

FIG. B

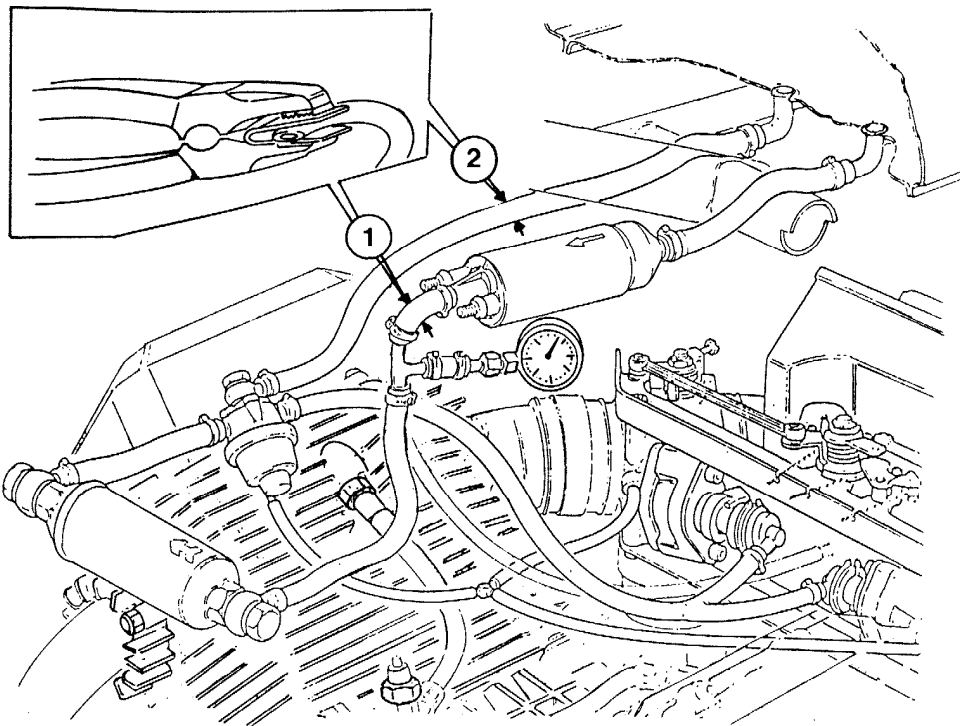

FIG. C

If the pressure in the circuit continues to drop, repeat the test as follows:

- close the pipe with the clamping pliers at position "2" (Fig C) on the recirculation pipes and turn the ignition key to the "ON" position. While the pumping is working, close off the tube also at position "1"
- the pressure shown on the gauge will be more than 73 psi. and must remain steady at that for a few seconds. If this happens, it means that the drop in pressure was caused by the pressure regulating valve which should be replaced;
- if the pressure continues to fall with the tube closed off at position "1" and "2", an injector is not closing properly. Identify which one and replace it.

If the pressure shown on the gauge is over 34-40 psi.: follow these steps (Fig. D):

- disconnect the pressure regulating valve from the recirculation hoses and temporarily install a hose from the regulating valve to a pail. Repeat the test by turning the ignition on.

If the pressure is 34-40 psi, look for trouble in the recirculation lines. If the pressure stays above 34-40 psi replace the pressure regulating valve. (Check whether the fuel filter had been replaced at 6,200 mile intervals as specified in the manual)

FIG. D

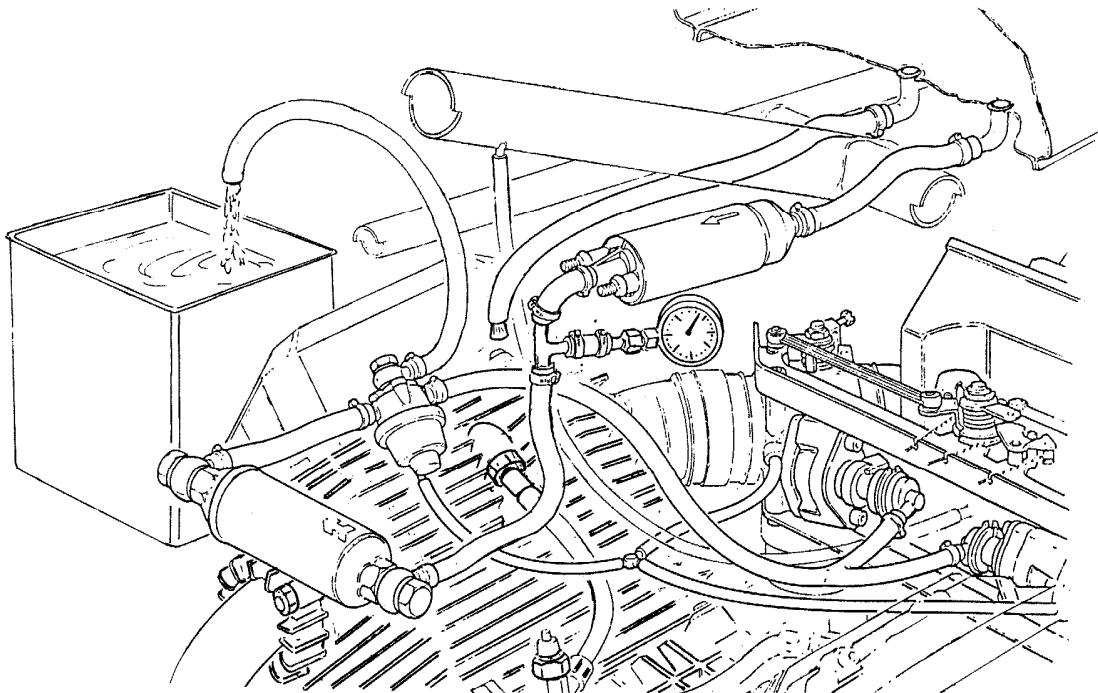

If the pressure shown on the gauge is less than 34-40 psi. or reaches 34-40 psi. very slowly, look for an obstruction between the pump and the filter or for something blocking the pump's intake. If none of these causes are involved, crimp the recirculation tube with the clamping pliers (Fig. E. pos. 2) and turn the ignition on. If the pressure jumps beyond 74 psi, replace the pressure regulating valve. If the pressure remains below 34-40 psi. replace the pump.

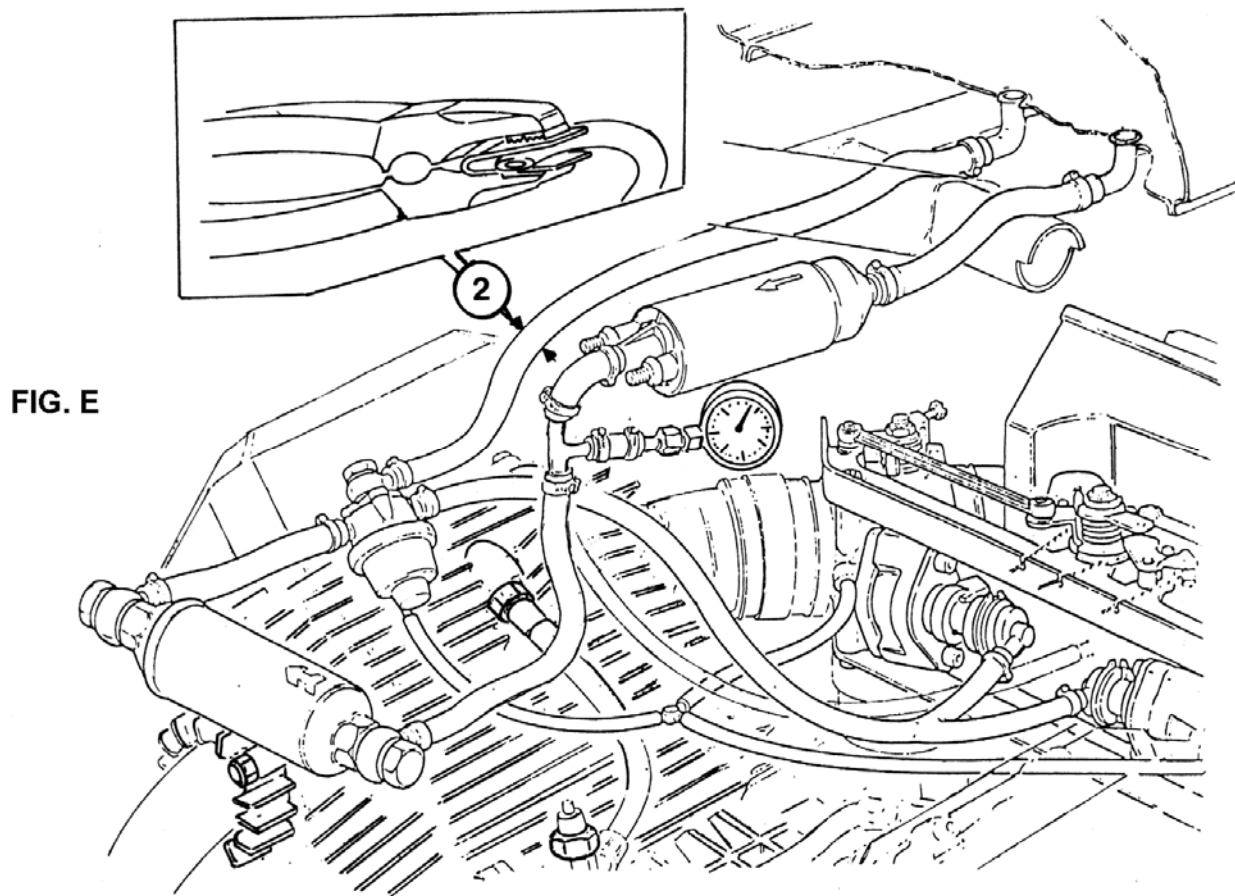

Note: It is good operating practice to replace the copper crush washers on the filter fittings after each service operation. The filter itself should be replaced after every 6,200 miles. When you are working on the fuel delivery system make sure that no dirt gets into the passages since this could damage the working parts.

“CHECK LAMP” DIAGNOSIS OF SYSTEM TROUBLES

The “CHECK LAMP” is a simple device that displays abnormalities detected by the computer when the motorcycle was last run. The display consists of a series of flashes, the meaning and diagnosis of which are described below.

The IAW fault detection system is autodiagnostic. It detects faults and retains their associated diagnostic codes in memory for display at a later time even if the fault is intermittent.

The “Check Lamp” autodiagnostic system is designed only to monitor the signals from the various input sensors. It has no capability to control the actuation signals sent to the devices controlled by the computer.

IMPORTANT: The diagnostic code(s) are retained in memory as long as the ignition is “ON”. The codes are lost when the ignition is switched off.

Codes transmission: The transmission consists of a series of flashes with pauses of different duration. Every error code is formed by two separate numbers; every number is expressed by an equivalent

number of flashes; a longer pause separates the two numbers; the beginning and the ending of the code are shown by a continuous series of flashes (see example page 24).

Note: The device transmits only one code pair at a time. It is necessary to detect not only the first transmitted code, but also all subsequent codes until the end of the sequence.

CONNECTIONS AND WORKING

- "CHECK LAMP" "A" can be connected any time, whether the engine is on or off or the ignition is on or off.
- The autodiagnosis socket "B" is located next to the computer "C".

If the check lamp doesn't light, there is no diagnostic code stored in the computer.

Possible causes:

- 1) There is no code present or the fault can not be determined by the autodiagnostic system.
- 2) There was a code present but it was erased when the ignition was turned off.

Note: It is also possible that a code is stored in the computer, but it can not be displayed on the check lamp.

Possible causes:

Misconnected check lamp or disconnected autodiagnostic connections;

Check lamp itself defective. Check the lamp by turning the ignition on, and then:

- Cause a fault by disconnecting the oil or air temperature sensor.
- If the fault is detected, the check lamp works, but the computer didn't store the code. This could indicate a problem somewhere in the system that can not be detected by the autodiagnostic system.
- If the fault is not detected, check the check lamp connections. Make sure the code was not inadvertently erased by turning the ignition off.

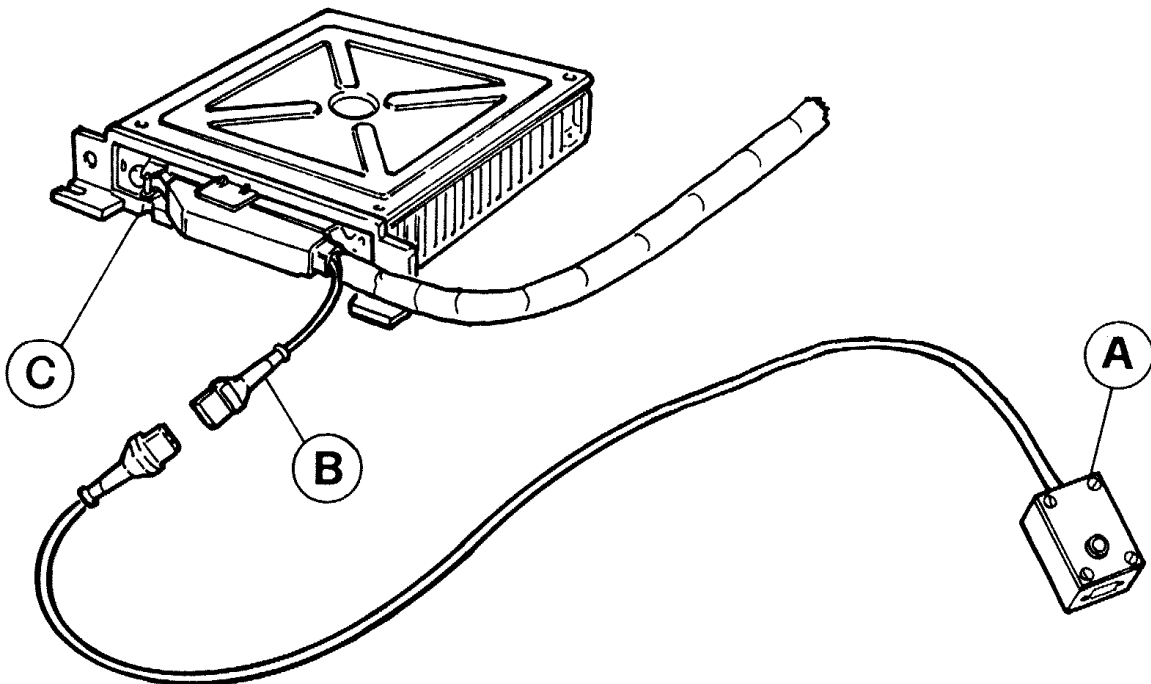

EXAMPLE

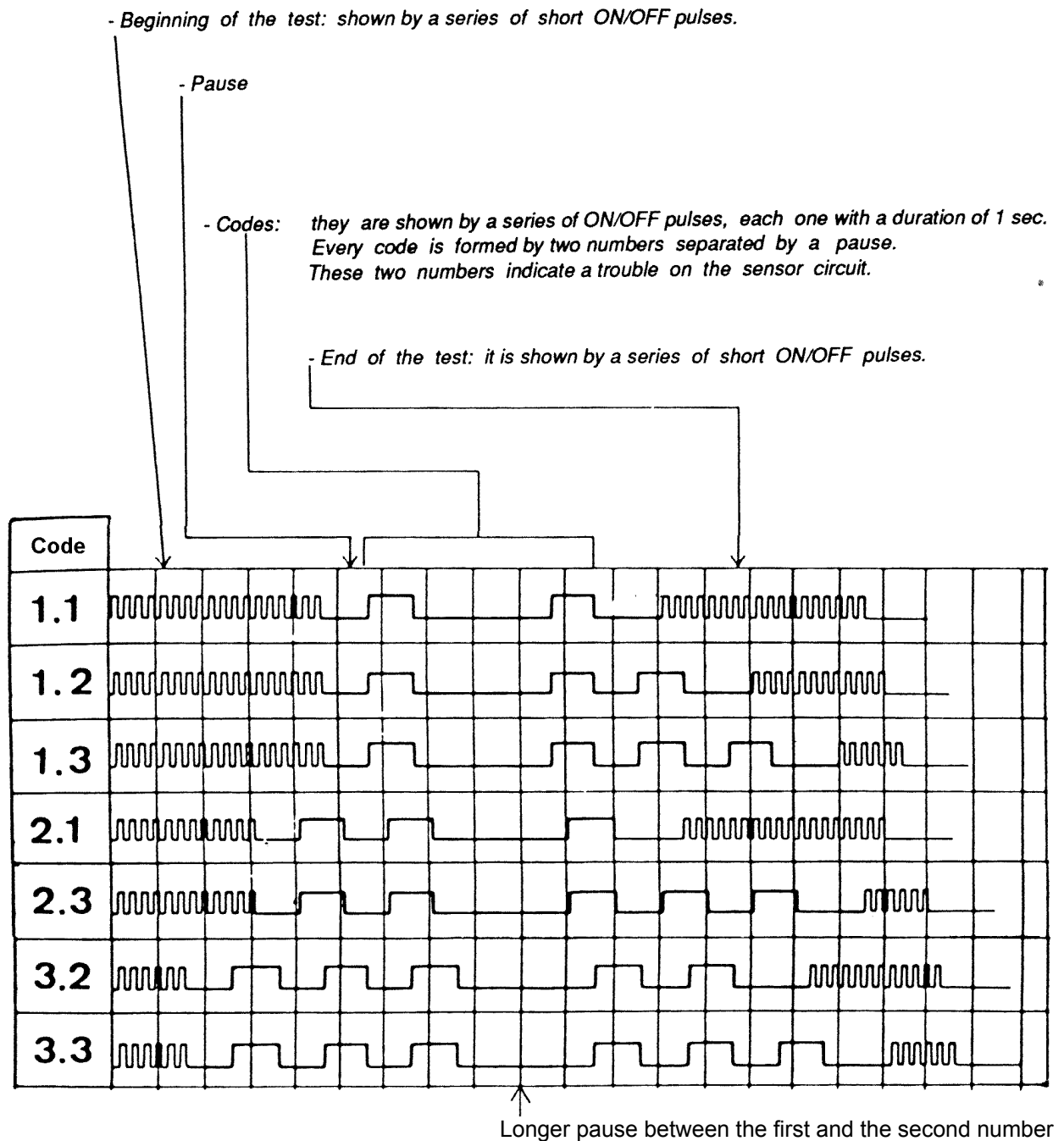

CHECK LAMP SIGNALS LEGEND

TROUBLE CODE 1.1

RPM signal failure

The problem can be in the sensor itself (circuit opened), in the wiring or in the connector (circuit opened). It can also be caused by an excessive air gap. When this fault is intermittently occurs during running, the code 1.1 is present together with the code 1.3.

When code 1.1 is present with code 1.3, check the air gap on the bell housing sensor.

TROUBLE CODE 1.2

Phase signal (TDC) failure

The trouble can be in the sensor itself (circuit opened), in the wiring or in the connector (circuit opened). It can also be caused by an excessive air gap. When this fault is intermittently occurs during running the code 1.2 is present together with the code 1.3.

When code 1.2 is present with code 1.3, check the air gap on the timing case sensor.

TROUBLE CODE 1.3

Incorrect signal sequence

1) If It appears together with the code 1.1

Faulty signal sequence due to a problem with the rpm sensor:

- RPM sensor itself (disconnected or shorted).
- RPM sensor wiring (disconnected or shorted).

2) If It appears together with the code 1.2

Faulty signal sequence due to a problem with the TDC sensor:

- TDC Sensor itself (disconnected or shorted)
- TDC sensor wiring (disconnected or shorted).

3) If It is not together with the code 1.1 or code 1.2

Faulty signal sequence due to:

- Faulty air gaps (RPM & TDC sensors)
- Irregular air gap caused by a misalignment or eccentricity of the timing gear or flywheel assembly.

Note: Code 1.3 is only detectable with the engine ON.

TROUBLE CODE 2.1

Faulty air temperature signal

The trouble can be:

- Air temperature sensor itself (disconnected or shorted)
- Air temperature sensor wiring or connector (disconnected or shorted)

TROUBLE CODE 2.3

Faulty oil temperature signal

The trouble can be:

- Oil temperature sensor itself (disconnected or shorted)
- Oil temperature sensor wiring or connector (disconnected or shorted)

TROUBLE CODE 3.2

Faulty signal from the barometric pressure sensor.

The trouble can be:

- Defective pressure sensor.
- Damaged or defective connections/wiring.

TROUBLE CODE 3.3

Faulty signal from the throttle potentiometer.

The trouble can be:

- Defective TPS potentiometer.
- Damaged or defective wiring/connections.

ELECTRONIC IGNITION/INJECTION CABLE ASSY

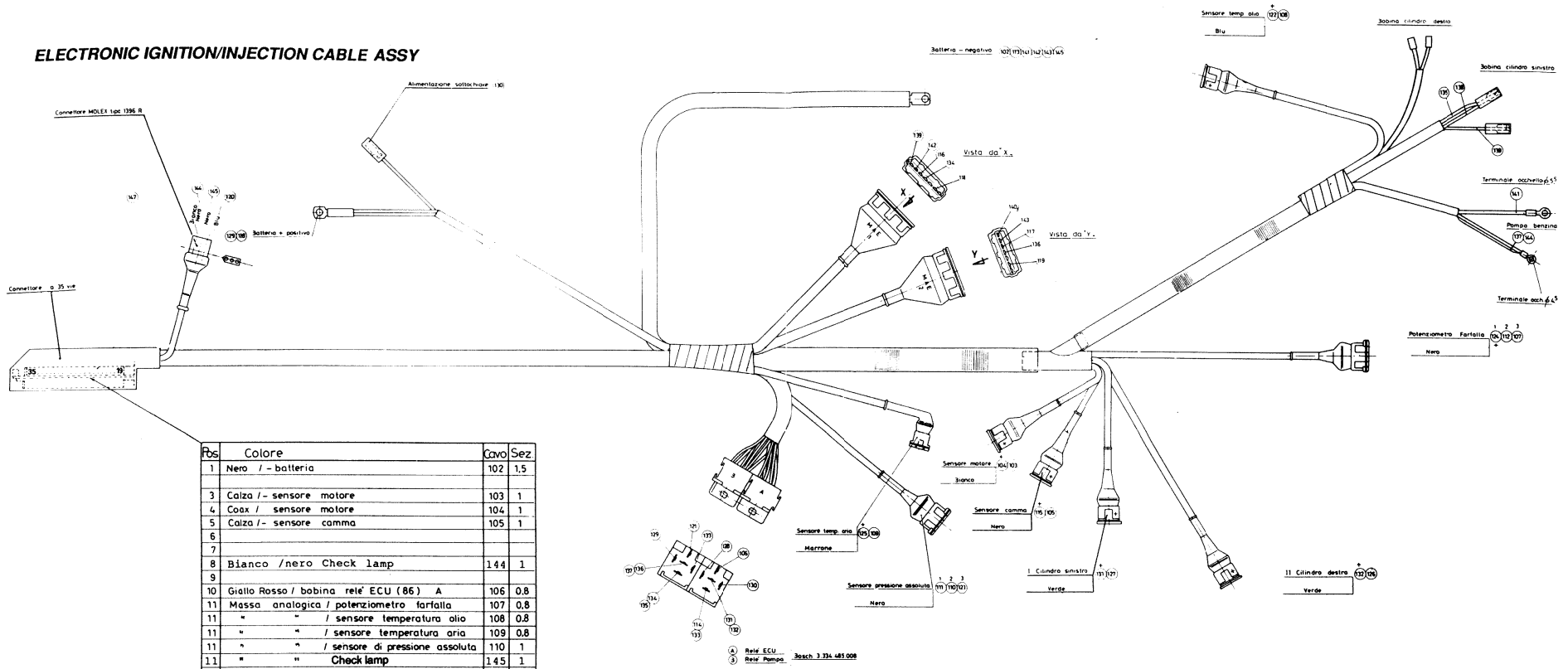

Pos	Colore	Cavo	Sez
1	Nero / - batteria	102	1,5
3	Calza / - sensore motore	103	1
4	Coax / sensore motore	104	1
5	Calza / - sensore camma	105	1
6			
7			
8	Bianco /nero Check lamp	144	1
9			
10	Giallo Rosso / bobina relè ECU (86) A	106	0,8
11	Massa analogica / potenziometro farfalla	107	0,8
11	" / sensore temperatura olio	108	0,8
11	" / sensore temperatura aria	109	0,8
11	" / sensore di pressione assoluta	110	1
11	" " Check lamp	145	1
13			
14			
15	Coax - Nero / pressione assoluta	111	1
16			
17	Coax - Nero / potenziometro farfalla	112	1
18			
19	Nero / - batteria	113	1,5
20	Marrone / relè ECU (87) A	114	1,5
21			
22			
23	Coax / + sensore camma	115	1
24	Calza / modulo accensione M.A.E.1	116	1
24	" / " " M.A.E. 2	117	1
25	Coax / + M.A.E. 1	118	1
26	Coax / + M.A.E. 2	119	1
27	3lu / Check lamp	120	0,8
28	Rosso Verde / relè pompa (86) B	121	0,8
29	Coax / sensore temperatura olio motore	122	1
30	Coax - Giallo / pressione assoluta	123	1
30	Coax - Giallo / potenziometro farfalla	124	1
31	Coax / sensore temperatura aria	125	1
32			
33	Azzurro / Iniettore 11 cilindro destro	126	1,5
34			
35	Rosa / Iniettore 1 cilindro sinistro	127	1,5

Cavo	Da	A	Colore	Sez
128	Batteria + / relè ECU (30)	A	Rosso	2,5
129	Batteria + / relè Pompa (30)	A	Rosso	2,5
130	Aliment. solenoide / relè ECU (85)	A	Bianco Marrone	0,8
131	Relè ECU (87) / iniettore 1 cilin. sinis. A	A	Marrone	0,8
132	Relè ECU (87) / iniettore 11 cilin. destro A	A	Marrone	0,8
133	Cavallotto relè ECU(87) / relè Pompa (85) B	A	Marrone	0,8
134	Relè pompa (87) / MAE 1 (pos. 4)	3	Grigio	1,5
135	Relè pompa (87) / bobina cilin. sinistro	3	3lu	1,5
136	Relè pompa (87) / MAE 2 (pos. 4)	3	Giallo	1,5
137	Relè pompa (87) / pompa benzina + 3	3	Viola	1,5
138	Bobina cilin. sinis. / bobina cilin. dest.	3	3lu	1,5
139	MAE 1(pos.1) / bobina cilin. sinistro	3	Verde	1,5
140	MAE 2(pos.1) / bobina cilin. destro	3	Verde Nero	1,5
141	Batteria - / pompa benzina -	3	Nero	1,5
142	Batteria - / MAE 1 (pos. 2)	3	Nero	1,5
143	Batteria - / MAE 2 (pos. 2)	3	Nero	1,5
144	Pompa + - sonda lambda	3	Rosso	0,8
145	Batteria - sonda lambda	3	Bianco	0,8

SCHEMA ELETTRICO
ELECTRIC SYSTEM SCHEME

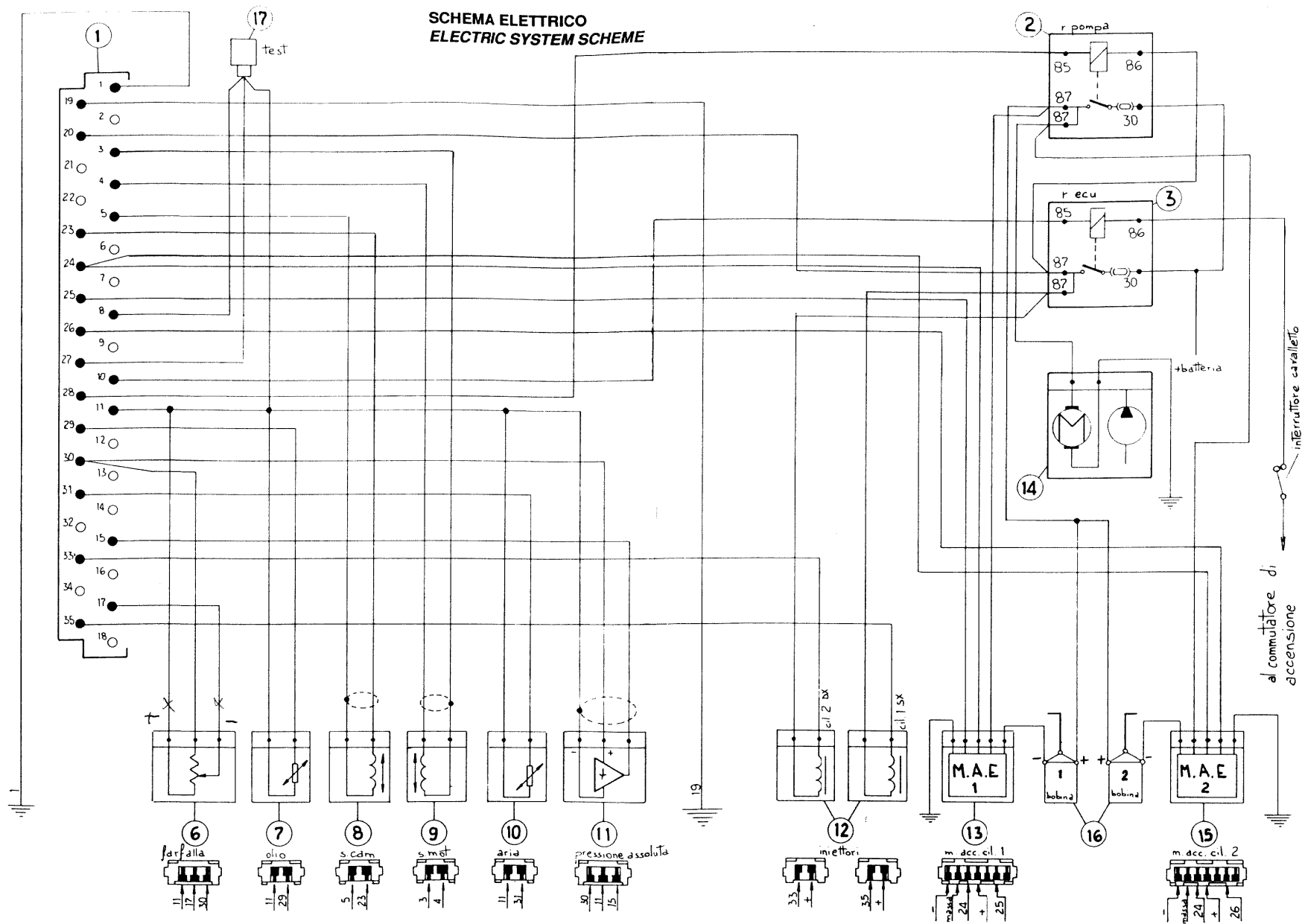

- 1 Connettore a 35 poli per centralina
- 1 35 pole connector for electronic device
- 2 Relè pompa e relativo zoccolo
- 2 Pump relay and its base
- 3 Relè centralina e relativo zoccolo
- 3 Device relay and its base

- 6 Potenziometro farfalla
- 6 Throttle potentiometer
- 7 Sensore temperatura olio
- 7 Oil temperature sensor
- 8 Sensore di fase s.cam.
- 8 Sensor of phase for the position of the camshaft

- 9 Sensore di giri (P.M.S.) s.mot.
- 9 Sensor of turns (TDC) for motor sensor
- 10 Sensore di temperatura aria
- 10 Sensor of air temperature
- 11 Sensore di pressione assoluta
- 11 Sensor of absolute pressure

- 12 Elettroiniettori
- 12 Electroinjectors
- 13 Modulo elettronico Marelli
- 13 Marelli electronic module
- 14 Pompa carburante
- 14 Fuel pump

- 15 Modulo elettronico Marelli
- 15 Marelli electronic module
- 16 Bobine
- 16 Coils
- 17 Test

al commutatore di accensione

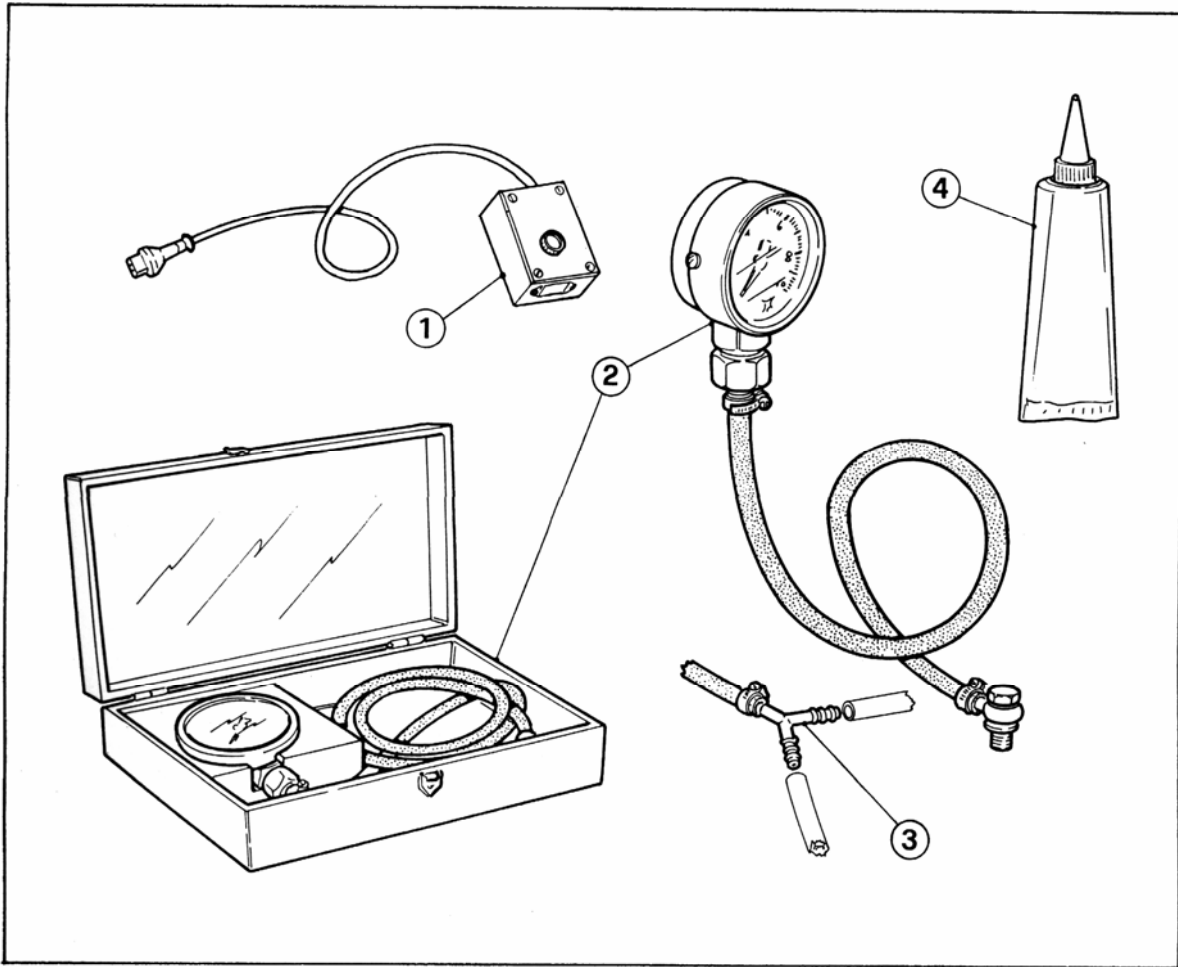

Pos.	Part No.	Description
1	00 97 00 00	Tester "CHECK LAMP"
2	00 95 00 55	<i>Gauge for engine oil pressure and fuel pressure checking, valids for bike equipped with electronic injection</i>
3	29 10 66 50	<i>Pipe 3-ways to survey the electronic injection fuel pressure</i>
		SPECIAL PRODUCT
4	00 01 04 02	<i>Electric contact grease</i>