

# Grant Condensing

Indoor Wall Hung Oil Boiler Range

## Installation & Servicing Instructions



EFFICIENT HEATING SOLUTIONS

# Commissioning Report

## For use with Kerosene only.

After installing the boiler leave these instructions with the User.

This appliance is deemed a controlled service and specific regional statutory requirements may be applicable.

Date: \_\_\_\_\_

Commissioning engineer: \_\_\_\_\_ Tel. No: \_\_\_\_\_

Boiler model/output: \_\_\_\_\_ kW

Fuel type: Kerosene

Nozzle size: \_\_\_\_\_ Pump pressure: \_\_\_\_\_

Air setting: \_\_\_\_\_ Flue gas % CO<sub>2</sub>: \_\_\_\_\_

Net flue gas temp: \_\_\_\_\_ Smoke No: \_\_\_\_\_



**EFFICIENT HEATING SOLUTIONS**

## **GRANT ENGINEERING (IRELAND) LIMITED**

Crinkle, Birr, Co. Offaly, Ireland

Tel: (057) 91 20089 Fax: (057) 91 21060

Email: [info@grantengineering.ie](mailto:info@grantengineering.ie) [www.grantengineering.ie](http://www.grantengineering.ie)

This manual is accurate at the date of printing but will be superseded and should be disregarded if specifications and/or appearances are changed in the interests of continued product improvement.

All goods sold are subject to our official Conditions of Sale, a copy of which may be obtained on application.

© Grant Engineering (Ireland) Limited 2008. No part of this manual may be reproduced by any means without prior written consent.

# Contents

<b>1</b>	<b>Introduction</b>	<b>4</b>	<b>7</b>	<b>Electrical</b>	<b>21</b>
1.1	How a condensing boiler works	4	7.1	Connecting the power supply	21
1.2	Boiler Description	4	7.2	Frost protection	21
1.3	Boiler Components	5	7.3	Control system wiring diagrams	22
<b>2</b>	<b>Technical Data</b>	<b>6</b>	7.4	Boiler control panel wiring diagrams	23
2.1	Boiler technical data – Condensing wall-hung boilers	6	<b>8</b>	<b>Flue System &amp; Air Supply</b>	<b>24</b>
2.2	Condensing boilers using Class C2 kerosene	7	8.1	Air supply	24
2.3	Flue gas analysis	7	8.2	Conventional flue systems	25
2.4	Boiler panel assembly	8	8.3	Connecting a conventional flue	27
<b>3</b>	<b>Oil Storage &amp; Supply System</b>	<b>9</b>	8.4	Balanced flue systems	27
3.1	Fuel supply	9	8.5	Prepare the wall	31
3.2	Burner oil connection	11	8.6	High level and vertical balanced flue	31
<b>4</b>	<b>Boiler Installation Information</b>	<b>13</b>	<b>9</b>	<b>Commissioning</b>	<b>32</b>
4.1	Introduction	13	9.1	Before switching on	32
4.2	Boiler location	13	9.2	Switching on	32
4.3	Preparation for installation	13	9.3	Running the boiler	33
4.4	Dismantling the boiler	13	9.4	Balancing the system	33
4.5	Installing the boiler	15	9.5	Completion	33
4.6	Regulations compliance	16	<b>10</b>	<b>Boiler Servicing</b>	<b>34</b>
4.7	Completion	17	10.1	Checking before servicing	34
4.8	Before you commission	17	10.2	Dismantling prior to servicing	34
4.9	Heating system design considerations	17	10.3	Cleaning the boiler	34
4.10	Underfloor heating systems	17	10.4	Cleaning the burner	35
4.11	Pipework materials	17	<b>11</b>	<b>Fault Finding</b>	<b>36</b>
4.12	Underfloor pipework	17	11.1	Burner fault finding	36
<b>5</b>	<b>Pipe Connections</b>	<b>18</b>	11.2	Boiler fault finding	39
5.1	Water connections	18	<b>12</b>	<b>Spare Parts</b>	<b>40</b>
<b>6</b>	<b>Condensate Disposal</b>	<b>19</b>	<b>13</b>	<b>Health &amp; Safety Information</b>	<b>42</b>
6.1	General requirements	19	13.1	Insulation materials	42
6.2	Connections	19	13.2	Kerosene and gas oil fuels (mineral oils)	42
6.3	Pipework	19	<b>14</b>	<b>EC Declaration of Conformity</b>	<b>43</b>
6.4	External pipework	19			
6.5	Condensate soakaway	19			
6.6	Condensate trap	20			
6.7	Condensate disposal pipework	20			
6.8	Inspection and cleaning of trap	20			

# 1 Introduction

This manual is intended to guide engineers in the installation and maintenance of Grant CONDENSING Wall Hung boilers. A User Guide for the operation of this boiler is attached to the reverse of this manual.

The following special text formats are used in this manual for the purposes listed below:

## WARNING

Warning of possible human injury as a consequence of not following the instructions in the warning.

## CAUTION

Caution concerning likely damage to equipment or tools as a consequence of not following the instructions in the caution.

## NOTE

Note text. Used for emphasis or information not directly concerned with the surrounding text but of importance to the reader.

### 1.1 How a Condensing Boiler Works

During the combustion process, hydrogen and oxygen combine to produce heat and water vapour. The water vapour produced is in the form of superheated steam in the heat exchanger. This superheated steam contains sensible heat (available heat) and latent heat (heat locked up in the flue gas). A conventional boiler cannot recover any of the latent heat and this energy is lost to the atmosphere through the flue.

The Grant CONDENSING Wall Hung condensing boiler contains an extra heat exchanger which is designed to recover the latent heat normally lost by a conventional boiler. It does this by cooling the flue gases to below 90°C, thus extracting more sensible heat and some of the latent heat. This is achieved by cooling the flue gases to their dew point (approximately 55°C).

To ensure maximum efficiency, the boiler return temperature should be 55°C or less, this will enable the latent heat to be condensed out of the flue gases.

The boiler will achieve net thermal efficiencies of 100%.

To achieve maximum performance from the Grant CONDENSING Wall Hung boiler, it is recommended that the heating system is designed so that a temperature differential of 20°C between the flow and return is maintained. The use of modulating circulating pumps (now widely available) and effective control systems should be considered.

The Grant Condensing boiler will however still operate at extremely high efficiencies even when it is not in condensing mode and therefore is suitable for fitting to an existing heating system without alteration to the radiator sizes. The boiler is capable of a maximum flow temperature of 75°C.

### 1.2 Boiler Description

The Grant CONDENSING Wall Hung range of automatic pressure jet oil boilers have been designed for use with a fully pumped central heating system with indirect domestic hot water cylinder. They are not suitable for use with either a direct cylinder or a 'primatic' cylinder or gravity hot water.

The boilers are suitable for use on sealed central heating systems.

All models are supplied with the control panel and burner factory fitted.

The boilers can be connected to either a conventional flue system or a balanced flue system, as required.

### For Conventional Flue Applications

Where a chimney is to be lined - Grant recommends the use of the Grant 'Orange' flue system, specifically designed for the Condensing range of condensing boilers. Refer to Section 9.2 for further details.



## NOTE

The flue system materials and construction **MUST** be suitable for use with oil-fired condensing boilers. Failure to fit a suitable conventional flue may invalidate the warranty on the boiler.

### For Balanced Flue Applications

The following flue kits are available from your local stockist.

Refer to Section 9.4 for further details.

### Yellow System

Standard low level concentric balanced flue - components available:

- Low level concentric balanced flue short - standard
- Extensions 225mm, 450mm and 675mm
- 90° extension elbow
- 45° extension elbow
- 45° elbow

### Green System

Standard external high level/vertical flue starter kit (room sealed) - components available:

- External high level/vertical flue starter kit short
- (room sealed)
- Extensions 150mm, 250mm, 450mm, 950mm
- and adjustable 195 to 270mm
- 45° elbow
- High level terminal
- Vertical terminal

### White System

High level concentric balanced flue kit - components available:

- Extensions 225mm, 450mm, 950mm
- and adjustable 275 to 450mm
- 45° elbow
- Vertical concentric balanced flue kit
- Extensions 225mm, 450mm, 950mm
- and adjustable 275 to 450mm
- 45° elbow

### 1.3 Boiler Components

All burners are pre-set for use with kerosene and are supplied ready to connect to a two pipe fuel supply system with two flexible fuel lines and  $\frac{3}{8}$ " to  $\frac{1}{4}$ " BSP male adaptor supplied with the boiler.

The temperature of the water leaving the boiler to heat the radiators and hot water cylinder is User adjustable.

The boiler is fitted with an overheat thermostat (which allows it to be used on a sealed central heating system) which will automatically switch off the boiler if the heat exchanger exceeds a pre-set temperature of  $111^{\circ}\text{C} \pm 3^{\circ}\text{C}$ .

The control panel is fitted with an ON/OFF switch, boiler thermostat control knob and the manual reset button for the overheat thermostat.

To access the controls, open the lower front panel by pulling it down as shown in Figure 1-1.

The controls are shown in Figure 1-2.



Figure 1-1: Boiler lower front panel in down position



Figure 1-2: Boiler controls

# 2 Technical Data

## 2.1 Boiler Technical Data – Condensing Wall-hung Boilers

Model		Kitchen/Utility	
		40/55	55/70
Water content	Litres	11	11
	Gal	2.4	2.4
Weight - complete boiler (dry)	kg	85.7	92.2
	lbs	189	203
Weight - boiler shell only (dry)*	kg	56.0	56.0
	lbs	123	123
Max heat input (kerosene)	kW	17.0	21.0
	Btu/h	58,000	71,650
Flow connection		22mm - connector (supplied fitted)	
Return connection		22mm - connector (supplied fitted)	
Min. flow rate $\Delta T=10^{\circ}\text{C}$	l/h	1420	1740
Min. flow rate $\Delta T=20^{\circ}\text{C}$	l/h	710	870
Condense connection		Accepts 21.5mm $\varnothing$ polypropylene overflow pipe	
Flue diameter (conventional flue)	mm	100mm	
Waterside resistance $\Delta T=10^{\circ}\text{C}$	mbar	28.5	
Waterside resistance $\Delta T=20^{\circ}\text{C}$	mbar	10	
Maximum static head	m	28	
Minimum circulating head	m	1	
Boiler thermostat range	$^{\circ}\text{C}$	65 to 75	
Limit (safety) stat cut-off temperature	$^{\circ}\text{C}$	111 $\pm$ 3	
Max casing temperature	$^{\circ}\text{C}$	less than 50	
Electricity supply		230V ~ 50Hz Fused at 5 Amp	
Motor power	Watts	75	
Starting current	Amps	2.25	
Running current	Amps	0.85	
Oil connections		1/4" Male BSP	
Conventional flue draught	N/m <sup>2</sup>	Min - 8.7 Max - 37	
	in.wg	Min - 0.035 Max - 0.15	
Max operating pressure - open system	bar	2.5	

\* Weight of shell - without baffles & clean-out door 45.7kg

## 2.2 Condensing Boilers using Class C2 Kerosene

Model	Heat Input		Heat output		SEDBUK	Nozzle	Oil pressure	Smoke	Burner head	Fuel flow	Flue gas	CO <sub>2</sub>
	kW	Btu/h	kW	Btu/h	efficiency		bar	rate No.	temp type	kg/h	°C	%
40/55	13.0	44,350	12.7	43,300	94.9	0.35 80°EH	7	0	No.1 Fixed	1.09	60 - 65	11 - 12
	14.5	49,470	*14.0	47,770	94.9	0.40 80°EH	10	0	No.1 Fixed	1.21	65 - 69	11 - 12
	17.0	58,000	16.5	56,300	94.9	0.50 80°EH	7	0	No.1 Fixed	1.43	65 - 69	11 - 12
55/70	17.0	58,000	16.5	56,300	93.8	0.50 80°EH	7	0	No.1 Fixed	1.43	65 - 69	11 - 12
	19.3	65,850	*18.7	63,800	93.8	0.50 80°EH	10	0	No.1 Fixed	1.61	70 - 75	11 - 12
	21.0	71,650	20.3	69,270	93.8	0.60 80°EH	8	0	No.1 Fixed	1.82	75 - 79	11 - 12

### Notes:

1. Data given is approximate only.
2. The above settings may have to be adjusted on site for correct operation of burner.
3. Gas oil is not suitable for use with the Grant CONDENSING Wall Hung boiler range.
4. The net flue gas temperatures given above are  $\pm 10\%$ .
5. When commissioning the air damper must be adjusted to obtain correct CO<sub>2</sub> level.
6. \* Factory settings: 40/55  $\rightarrow$  14kW 55/70  $\rightarrow$  18.7kW
7. Combustion door test point may be used for CO<sub>2</sub> and smoke readings only. Do not use this test point for temperature or efficiency readings.
8. The installer must amend the boiler data label if the output is changed.

## 2.3 Flue Gas Analysis

To allow the boiler to be commissioned and serviced, the boiler is supplied with a combustion test point on the front cleaning door. When this test point is used please note the following:

- The test point is for CO<sub>2</sub> and smoke readings only.
- The boiler efficiency and temperature must be taken from the flue test point on high level, vertical and conventional flue adaptors.

Concentric low level flues do not contain a test point. The temperature and efficiency readings must be taken from the flue terminal.

### 2.3 Boiler Panel Assembly

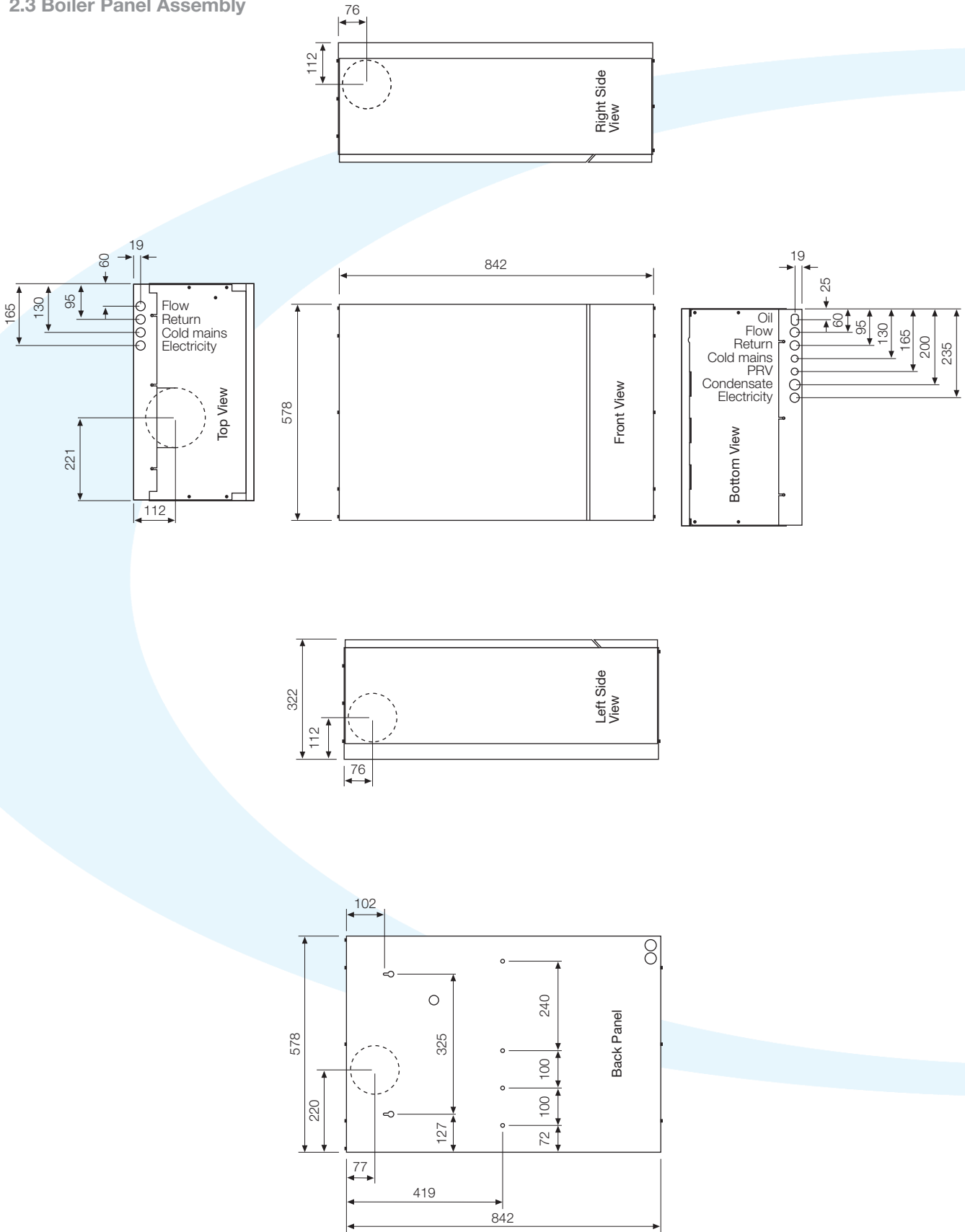

Figure 2-1: Grant CONDENSING Wall Hung boiler panel assembly

All dimensions in the diagram above are in millimetres.



## 3 Oil Storage & Supply System

### 3.1 Fuel Supply

#### Fuel Storage

The tank should be positioned in accordance with the recommendations given in BS 5410:1:1997, which gives details of filling, maintenance and protection from fire.

A steel tank may be used and must be constructed to BS 799:5:1987 and OFS T200.



#### CAUTION

**A galvanized tank must NOT be used.**

A plastic tank may be used and must comply with OFS T100.



#### NOTE

**Plastic tanks should be adequately and uniformly supported on a smooth level surface, across their entire load bearing base area, that is, the area in contact with the ground.**

#### Fuel Pipes

Fuel supply pipes should be of copper tubing with an external diameter of at least 10mm.

Galvanised pipe **must not** be used.

All pipe connections should preferably use flared fittings. Soldered connections **must not** be used on oil pipes.



#### CAUTION

**Flexible pipes must NOT be used outside the boiler case.**

A remote sensing fire valve must be installed in the fuel supply line (outside) where it enters the building, with the sensing head located above the burner.

Recommendations are given in BS 5410:1:1997.

A metal bowl type filter with a replaceable micronic filter must be fitted in the fuel supply line adjacent to the boiler. A shut-off valve should be fitted before the filter, to allow the filter to be serviced.

Two flexible fuel lines, adaptors and 1/4" BSP isolation valves are supplied loose with the boiler for the final connection to the burner, with a two pipe system or 'Tiger Loop' type de-aerator.

Metal braided flexible pipes should be replaced annually when the boiler is serviced. Long life flexible pipes should be inspected annually and replaced at least every 60 months.

**Two Pipe System - (See Figure 3-1)**

With the storage tank outlet below the burner, a two pipe system should be used. The pipe runs should be as shown in Figure 3-1. The return pipe should be at the same level in the tank as the supply pipe, both being 75 to 100mm above the base of the tank. The pipe ends should be a sufficient distance apart so as to prevent any sediment disturbed by the return entering the supply pipe.

Avoid the bottom of the tank being more than 3m below the burner.

A non-return valve should be fitted in the supply pipe together with the filter and fire valve. A non-return valve should be fitted in the return pipe if the top of the tank is above the burner.

The pump vacuum should not exceed 0.4 bar.

Beyond this limit gas is released from the oil.

For guidance on installation of top outlet fuel tanks and suction oil supply sizing, see OFTEC Technical Information Book 3. Available from OFTEC.

H (m)	Pipe Length (m)		
	ø 6mm	ø 8mm	ø 10mm
0.5	19	60	100
1	21	66	100
1.5	23	72	100
2	25	79	100
2.5	27	85	100
3	29	91	100
3.5	31	98	100

**Tiger Loop System - (See Figures 3-2 and 3-3)**

When the storage tank outlet is below the burner, an alternative to a two pipe system can be achieved using a 'Tiger Loop' type oil de-aerator. This effectively removes the air from the oil supply on a single pipe lift.

The de-aerator is connected close to the boiler as a two pipe system (omitting the non-return valve) as shown in Figure 3-2. Refer to the manufacturers instructions supplied with the de-aerator.

The de-aerator must be mounted vertically, Figure 3-2.

**WARNING**

To prevent any possibility of fuel fumes entering the building, the de-aerator **must** be fitted outside in accordance with BS 5410:1:1997.

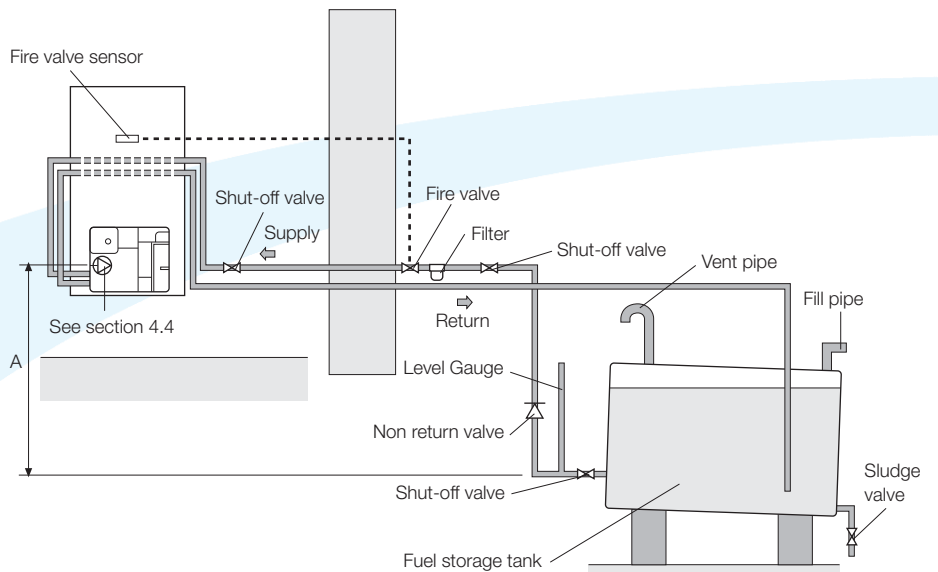

Figure 3-1: Two pipe system

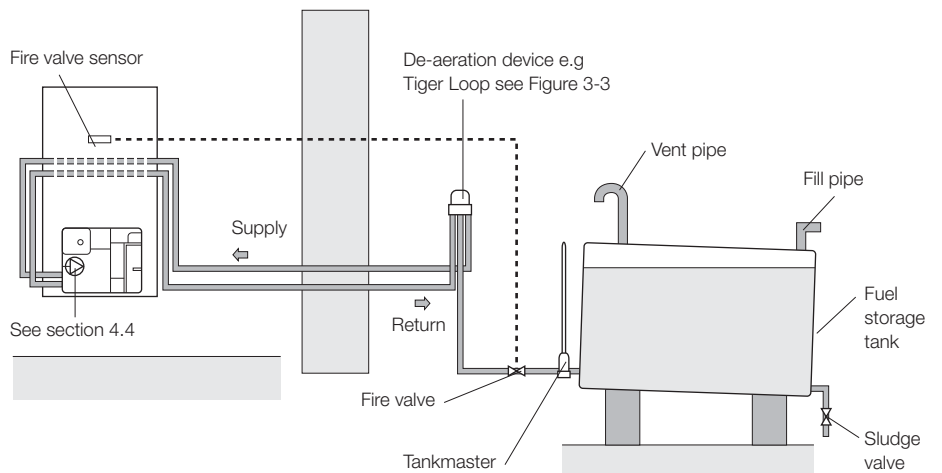

Figure 3-2: De-aeration device system

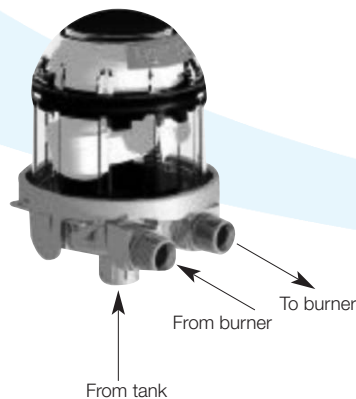
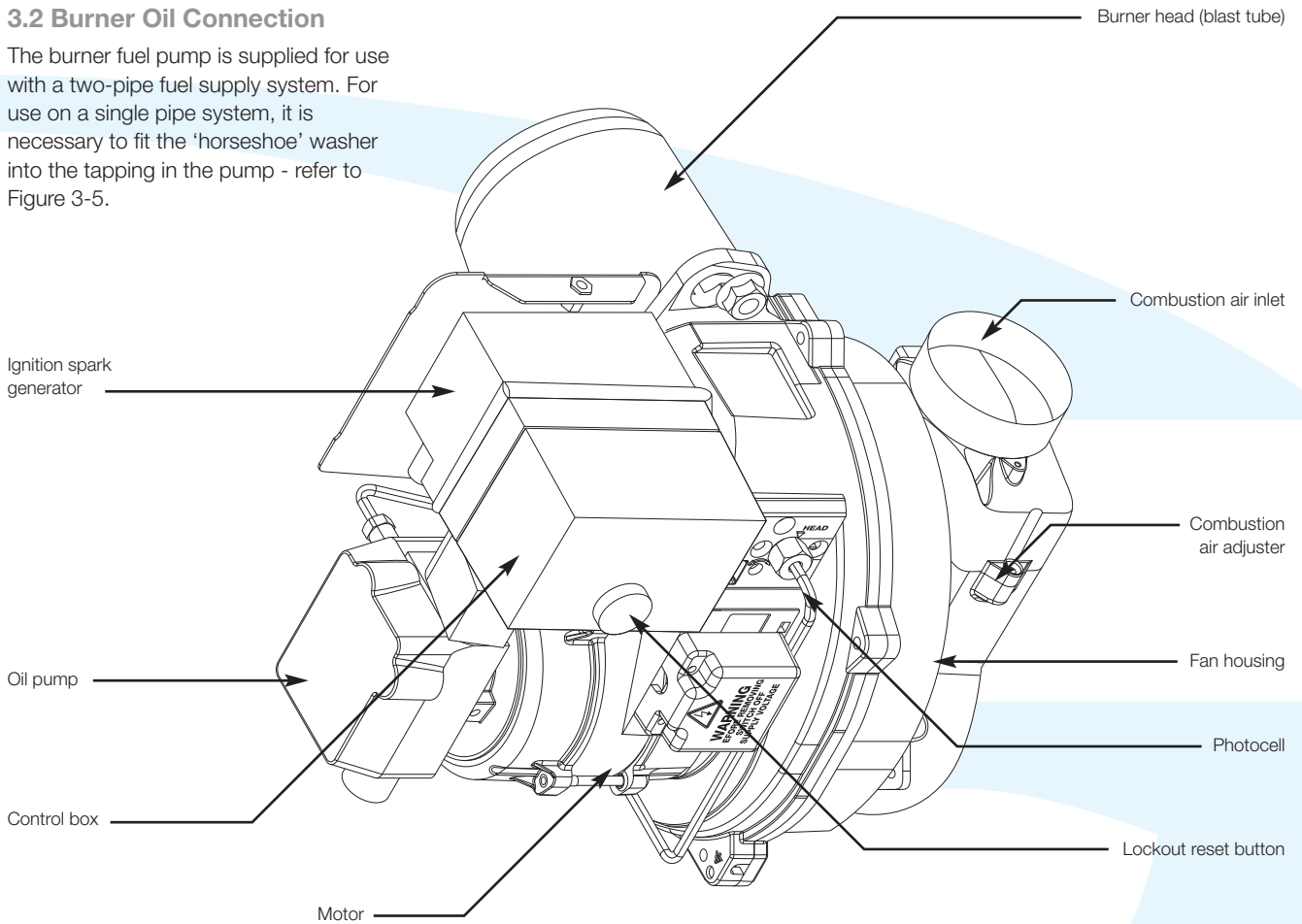

Figure 3-3: Tiger loop de-aeration device

### 3.2 Burner Oil Connection

The burner fuel pump is supplied for use with a two-pipe fuel supply system. For use on a single pipe system, it is necessary to fit the 'horseshoe' washer into the tapping in the pump - refer to Figure 3-5.



**Figure 3-4:** Burner components

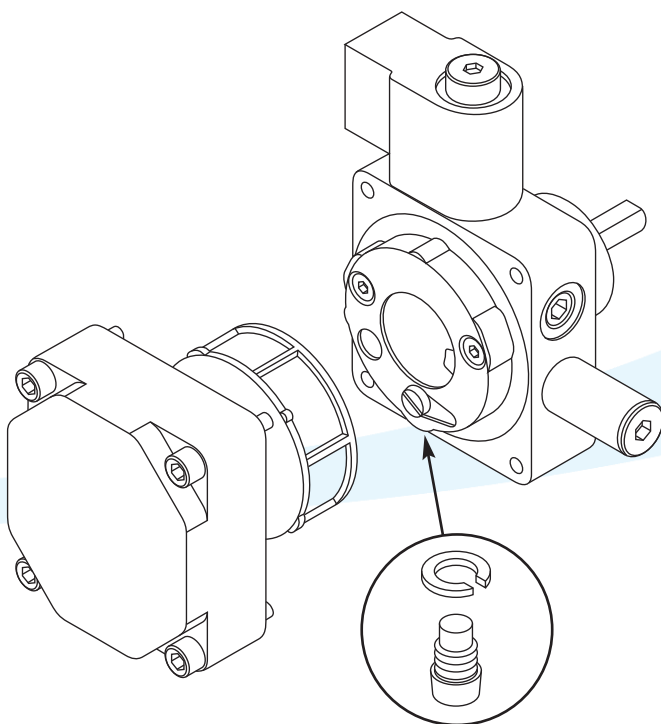

**Figure 3-5:** Fitting/location of 'horseshoe' washer

### Main Burner Components

Remove the control panel (secured by two screws) to gain access to the burner. It may be necessary to remove the burner from the boiler to access connections in the fuel pump.

To do this, unscrew the single nut at the top of the burner (using a 13mm spanner) and rotate the burner clockwise and withdraw the burner from the boiler, as shown in Figure 3-6.

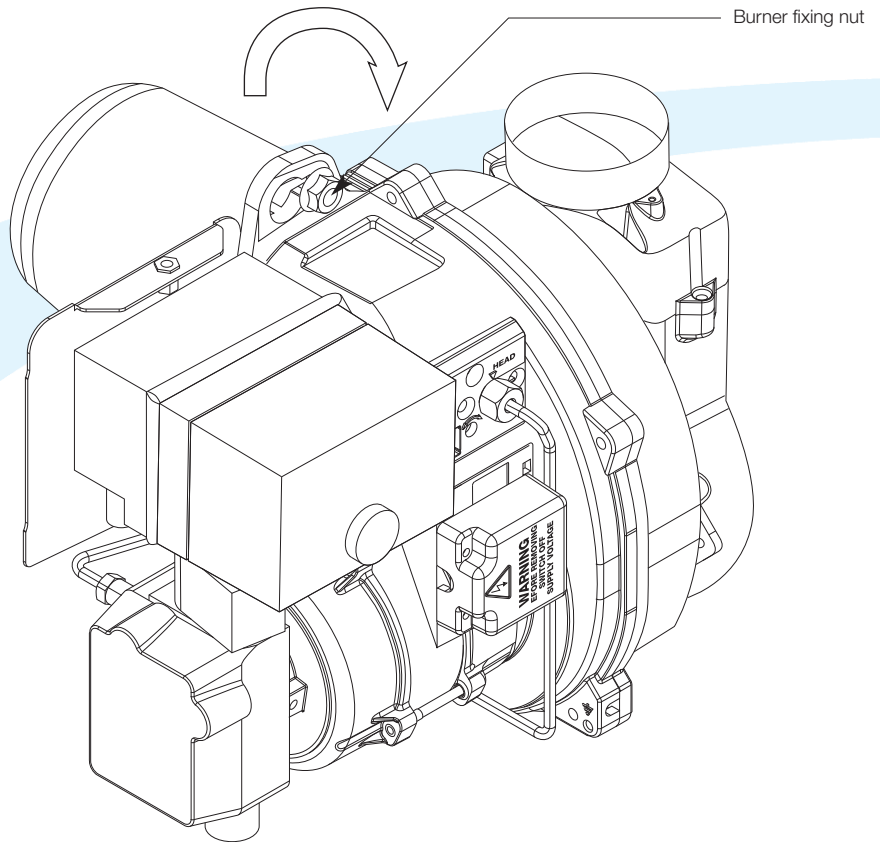

Figure 3-6: Burner removal

### Burner Connection

The procedure is as follows:

1. Remove and discard the blanking plugs from the suction (inlet) and return connections of the pump. Refer to figure 3-7.
2. Connect the suction and return oil flexible fuel lines to the pump.
3. Connect the  $\frac{3}{8}$ " to  $\frac{1}{4}$ " BSP adaptor to the flexible fuel line using the adaptor supplied. The supply enters through one of the holes in the casing.

Item	Description
01	Inlet (suction) port
02	Return port
03	Bleed and pressure gauge port
04	Vacuum gauge port
05	Pressure adjustment
06	Nozzle outlet

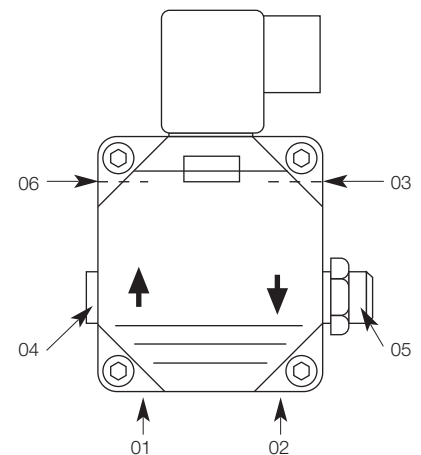

Figure 3-7: Danfoss BFP11 R3 oil pump

# 4 Boiler Installation Information

## 4.1 Introduction

The boiler is supplied already fully assembled in a carton which is carefully packed with packing materials. As the boiler is wall mounted all of the content of the boiler casing must be removed with the packaging before installation can begin, to give access to the rear fixing panel. The installation procedure therefore begins with unpacking and dismantling of the packed boiler.

## 4.2 Boiler Location

The boiler should be fixed to a wall that is firm, flat and vertical. It does not require any special base provisions as the temperature of the boiler casing is less than 50°C.

Sufficient clearance **must** be allowed at the front of and below the boiler to remove the burner and baffles for servicing.

## 4.3 Preparation for Installation

The following procedure must be performed before you can begin dismantling the boiler for installation:

1. With the boiler on the pallet, open the carton and remove all packing materials and the carton from the boiler.
2. Lift open lower front panel, slide panel to left or right and detach from the boiler.



Figure 4-1: Boiler front panel open

3. Remove upper front panel. Pull bottom edge of panel sharply upwards to disengage retaining clips and lift off from boiler.
4. Remove internal packaging from within boiler casing.
5. Remove filling loop and flexible oil hose packs from within boiler.

## 4.4 Dismantling the Boiler

Dismantle the boiler as follows, keeping all components, screws and washers for re-assembly:

1. Slacken off hose clip on burner air inlet and remove snorkel tube from boiler.



Figure 4-2: Dismantling the boiler

2. Unscrew earth wire from underside of top casing panel.
3. Slacken screws at rear of top casing panel and remove screws securing top panel to side panels. Pull panel forwards to remove from boiler.
4. Disconnect burner plug.
5. Unscrew inlet connection to condensate trap and remove trap from boiler.

6. Remove thermostat phials from their pocket (in right side of heat exchanger – below return connection).



Figure 4-3: Removing thermostat phials

7. Slacken control panel retaining screws and remove control panel from boiler.

11. Remove screws securing right hand side panel to bottom panel. Remove right hand side panel from boiler by lifting upwards to disengage tabs.
12. Repeat procedure to remove left hand side panel from boiler.
13. Slacken screws at rear of bottom casing panel and remove bottom panel from boiler.



**Figure 4-4:** Removing flow & return pipe

15. Unscrew compression connection on boiler shell and remove flow pipe from boiler.
16. Unscrew top right compression connection and remove return pipe from boiler.

17. Using a 13mm socket, slacken burner retaining nut (on top of burner). Rotate burner clockwise (towards rear of boiler), pull burner to the right until burner head is clear of mounting flange and remove burner from boiler.



**Figure 4-5:** Removing burner

18. Using 13mm spanner, unscrew the two clean-out door retaining nuts and remove door from front of boiler shell.

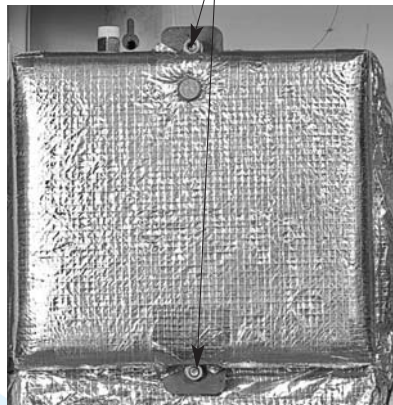

**Figure 4-6:** Removing clean-out door

19. Remove baffles from boiler shell.



**Figure 4-7:** Removing baffles from boiler shell

20. Undo retaining screw and remove transit bracket from top of boiler shell.
21. Push boiler shell upwards to disengage it from mounting bracket on back panel of boiler.
22. Lift boiler shell away from back panel and stand it upright on the four feet.
23. Unscrew and remove the two transit screws & nuts securing mounting bracket and back panel to pallet.

#### 4.5 Installing the Boiler

You are now ready to install the boiler. The procedure is as follows:

1. If a back outlet flue system is to be used, remove the large circular flue knockout from back panel. If the rear outlet PRV discharge is to be used, remove the knockout from the back panel (as shown in the figure below).

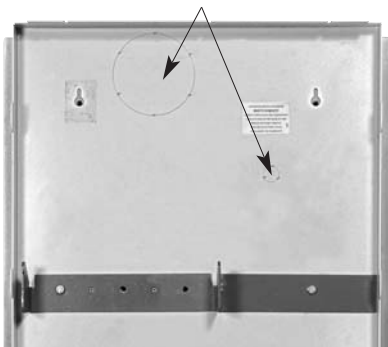

**Figure 4-8:** Installing the back panel

2. Locate and hold the back panel in the required position on the wall. Check it is level using a spirit level on the top flange. Mark position of the holes for the two keyhole slots. Remove the back panel from the wall.
3. Drill and fit wall fixing plugs in the two holes. Fit suitable screws and mount the back panel on the wall using the two keyhole slots. Check again that the back panel is level before proceeding.
4. Mark the position of the four mounting bracket fixings on to the wall from the back panel. Also mark the positions of the flow and return pipes, the electrical power supply, and the condensate discharge pipe.
5. If using a back outlet flue and/or rear PRV outlet is to be used, also mark these holes on to the wall.

### ! NOTE

If side outlet flue is to be used (to either left or right) then mark position as it may be necessary to cut flue hole BEFORE installing boiler on to wall.

6. Remove the back panel from the wall. Drill the holes for the mounting bracket fixings and fit the wall plugs provided. Drill all other necessary holes. If required, core drill the wall for a back outlet flue and drill a hole for the PRV discharge pipe. Re-mount the back panel on the two keyholes slots.

7. Locate the mounting bracket on to the back panel, aligning the four holes in the bracket with those in the back panel. Ensure that the mounting 'hooks' are pointing upwards and secure using the fixings supplied.

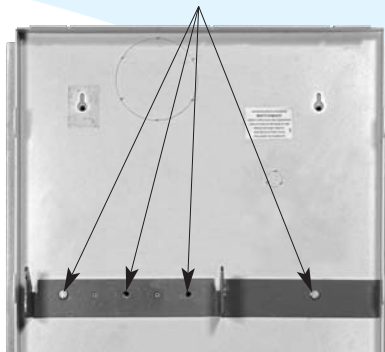

**Figure 4-9:** Fixing the back panel

8. Lift the boiler shell and hang it on the mounting bracket – ensuring that the mounting plates on either side of the shell are fully located in the vertical slot of both mounting hooks.
9. Re-fit the return pipe to top right hand connection on boiler shell. Pass return pipe from system through hole in back panel (either at top or bottom of panel, as required) and connect to boiler return pipe.



**Figure 4-10:** Re-fitting flow & return pipe

10. Re-fit flow pipe to compression connection on boiler shell. Pass flow pipe from system through hole in back panel (either at top or bottom of panel, as required) and connect to boiler flow pipe.

### ! NOTE

It is recommended that the system flow and return pipes are connected to the boiler at this point in the installation.

11. Re-fit burner. First remove burner securing nut, locate burner head into hole in burner flange/boiler shell and locate mounting screw through hole on top of burner. Re-fit nut and tighten to secure burner in place. Connect flexible oil lines from oil supply pipework to burner. It is recommended that the copper oil lines are installed at this stage while the side panels are not in place.
12. Re-fit baffles into boiler shell – ensuring they are in the correct order (check marking on each baffle) as shown below

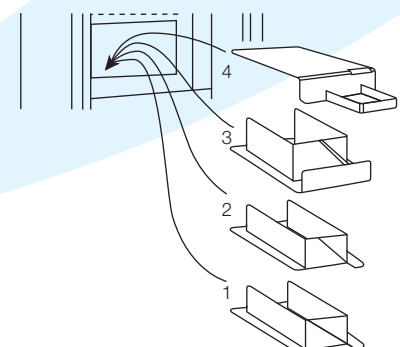

**Figure 4-11:** Re-fitting baffles into boiler shell

13. Locate clean-out door onto the two studs, re-fit nuts and tighten to secure door in place.
14. If side outlet flue system is to be used, remove flue 'knockout' from either the left or right side casing panel, as required.
15. Re-fit left hand casing panel locating tabs on rear edge of panel into slots in back panel. Firmly push side panel downwards to fully engage tabs.
16. Repeat process to re-fit right hand casing panel.
17. Re-fit bottom casing panel and secure in place with screws (with washers).
18. If top outlet flue system is to be used, remove the flue 'knockout' in both the top casing panel and the top flange of the back panel. Fit the boiler connector (supplied in the flue kit) to the top of the boiler shell, ensuring it is firmly connected and making a seal on the neoprene gasket. Refer to flue installation instructions for further details.
19. Re-fit top casing panel and secure in place with screws (with washers). Ensure that the ends of the front flange fit into the slots in the top front of side panels.
20. Re-fit control panel – locating fixing screws into slots in front flange of bottom panel. Tighten screws to secure.
21. Re-locate thermostat bulbs in pocket at rear right hand side of boiler shell.
22. Re-connect burner plug.

23. Re-fit condensate trap. Connect condensate discharge pipe to outlet of trap.



**Figure 4-12: Re-fitting condensate trap**

24. Re-fit snorkel tube to air inlet connection on burner. Tighten hose clip to secure.

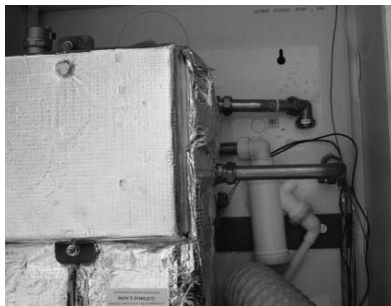

**Figure 4-13: Re-fitting snorkel tube**

25. If balanced flue system is fitted, connect other end of snorkel tube to air inlet spigot of flue system.
26. If a conventional flue system is used, locate other end of snorkel in top of boiler, ensuring that inlet to tube is not restricted.
27. Fit flue system to boiler – refer to flue system installation instructions.
28. Re-fit upper front casing panel – hook top edge over front edge of top panel, locate pins into spring retaining clip on each side panel and push firmly home to secure.
29. Re-fit lower front panel – with the panel at 45° to vertical, locate the tabs into the horizontal slots in front of bottom panel. Slide to either left or right and lift into closed position against magnetic catches.

## 4.6 Regulations Compliance

Installation of a Grant CONDENSING Wall Hung boiler must be in accordance with the following recommendations:-

- The Department of the Environment and any local Byelaws which you must check with the local authority for the area.
- Model and local Water Undertaking Byelaws.
- Applicable Control of Pollution Regulations.
- The following OFTEC requirements:
  - OFS T100 Polythene oil storage tanks for distillate fuels.
  - OFS T200 Fuel oil storage tanks and tank bunds for use with distillate fuels, lubrication oils and waste oils.

Further information may be obtained from the OFTEC Technical Information Book 3 (Installation requirements for oil fired boilers and oil storage tanks).

The installation should also be in accordance with the latest edition of the following British Standard Codes of Practice:

- BS 715 Metal flue pipes, fittings, terminals and accessories.
- BS 799:5 Oil storage tanks.
- BS 1181 Clay flue linings and flue terminals.
- BS 4543:3 Factory made insulated chimneys for oil fired appliances.
- BS 4876 Performance requirements for oil burning appliances.
- BS 5410:1 Code of Practice for oil firing appliances.
- BS 5449 Forced circulation hot water systems.
- BS 7593 Code of Practice for treatment of water in heating systems.
- BS 7671 Requirements for electrical installations, IEE Wiring Regulations.





## NOTE

Failure to install and commission appliances correctly may invalidate the boiler warranty.



## WARNING

Before starting any work on the boiler, or fuel supply please read the health and safety information given in Section 14.

### 4.7 Completion

Please ensure that the OFTEC CD/10 installation completion report (provided with the boiler) is completed in full.

Leave the top copy with the User.

Retain the carbon copy.

Ensure that the User Information pack (supplied with the boiler) is handed over to the Householder.

### 4.8 Before you Commission

To avoid the danger of dirt and foreign matter entering the boiler the complete heating system should be thoroughly flushed out - before the boiler is connected and then again after the system has been heated and is still hot. This is especially important where the boiler is used on an old system.

For optimum performance after installation, this boiler and its associated central heating system must be flushed in accordance with the guidelines given in BS 7593:1992 'Treatment of water in domestic hot water central heating systems'.

This must involve the use of a proprietary cleaner, such as BetzDearborn's Sentinel X300 or X400, or Fernox Restorer. Full instructions are supplied with the products, but for more details of BetzDearborn's products, view the website [www.sentinel-solutions.net](http://www.sentinel-solutions.net) and for more details of Fernox products view the website [www.fernox.com](http://www.fernox.com).

For Long term protection against corrosion and scale, after flushing, it is recommended that an inhibitor such as Betzdearborn's Sentinel X100 or Fernox MB-1 is dosed in accordance with the guidelines given in BS 7593:1992.

Failure to implement these guidelines will invalidate the warranty.

### 4.9 Heating System Design Considerations

To achieve the maximum efficiency possible from the Grant CONDENSING Wall Hung boiler, the heating system should be designed to the following parameters:

#### Radiators:-

- Flow temperature 70°C
- Return temperature 50°C
- Differential 20°C

#### Underfloor:-

- Flow temperature 50°C
- Return temperature 40°C
- Differential 10°C

Size radiators with a mean water temperature of 60°C.

Design system controls with programmable room thermostats or use weather compensating controls to maintain return temperatures below 55°C.

**The boiler should not be allowed to operate with return temperatures of less than 40°C when the system is up to operating temperature.**

The use of a pipe stat is recommended to control the return temperature when using weather compensating controls.

### 4.10 Underfloor Heating Systems

In underfloor systems it is essential that the return temperature must be maintained above 40°C to prevent internal corrosion of the boiler water jacket.

### 4.11 Pipework Materials

Grant boilers are compatible with both copper and plastic pipe. Where plastic pipe is used it must be of the oxygen barrier type and be of the correct class (to BS 7291:Part 1:1990) for the application concerned.



## NOTE

The first metre of pipework connected to both the heating flow and return connections of the boiler must be made in copper.



## WARNING

The system should incorporate a low-pressure switch to shut off power to the boiler if the system pressure drops below 0.2 bar. A suitable low pressure switch kit is available to purchase from Grant Engineering (IRELAND) Limited, Part No. MPCBS 62.

### 4.12 Underfloor Pipework

Plastic pipe may be used on Underfloor systems where the plastic pipe is fitted after the thermostatic mixing valve. Copper tube must be used for at least the first metre of flow and return primary pipework between the boiler and the underfloor mixing/blending valves.

# 5 Pipe Connections

## 5.1 Water Connections

### Flow and Return Connections - All models

On all models a 22mm compression connection is provided for both the heating flow and return connections.

Holes are provided in the top and bottom casing panels to route the pipework as required.



### NOTE

All pipes to be fitted into the compression connectors provided should be cut using a pipe slicer or pipe cutter - to leave the pipe ends with a slight radius and free from any burrs or sharp edges. Pipes to be used with these fittings should not be cut square using a hacksaw.

A drain cock is fitted at the bottom on the front of the boiler to allow the heating system to be drained.



Figure 5-1: Non-system boiler flow and return connections



Figure 5-3: Grant Condensing Wall Hung boiler with front casing removed

# 6 Condensate Disposal

## 6.1 General Requirements

When in condensing mode the Grant CONDENSING Wall Hung boilers produce condensate from the water vapour in the flue gases. This condensate is slightly acidic with a pH value of around 3 (similar to vinegar). Provision must be made for the safe and effective disposal of this condensate.

Condensate can be disposed of using one of the following methods of connection:

### Internal Connection (preferred option):

- Into an internal domestic waste system (from kitchen sink, washing machine, etc.).
- Directly into the soil stack

### External Connection:

- Into an external soil stack
- Into an external drain or gully
- Into a rainwater hopper (that is part of a combined system where sewer carries both rainwater and foul water)
- Purpose made soakaway

All condensate disposal pipes **must** be fitted with a trap - whether they are connected internally or externally to a domestic waste system/soil stack or run externally to a gully, hopper or soakaway.

## 6.2 Connections

Connections into a rainwater hopper, external drain or gully should be terminated inside the hopper/drain/gully below the grid level but above the water level.

Condensate disposal pipes should not be connected directly into rainwater downpipes or to waste/soil systems connected to septic tanks.

Condensate should not be discharged into 'grey water' systems that re-use water used in the home (not including water from toilets).

It should be noted that connection of a condensate pipe to the drain may be subject to local Building Control requirements.

## 6.3 Pipework

Condensate disposal pipework must be plastic (plastic waste or overflow pipe is suitable).

### NOTE

Copper or steel pipe is NOT suitable and MUST NOT be used.

Condensate disposal pipes should have a minimum 'nominal' diameter of 22mm ( $\frac{3}{4}$ " ) - e.g. use 21.5mm OD polypropylene overflow pipe.

Condensate disposal pipes must be fitted with a fall (away from the boiler) of at least 2.5° (~45mm fall per metre run).

### NOTE

Where it is not possible for the pipe to fall towards the point of discharge - either internally into a waste system or externally to a gully (e.g. for boilers installed in a basement), it will be necessary to use a condensate pump.

Condensate disposal pipes should be kept as short as possible and the number of bends kept to a minimum.

Pipes should be adequately fixed to prevent sagging, i.e. at no more than 0.5 metre intervals.

## 6.4 External Pipework

Ideally, external pipework, or pipework in unheated areas, should be avoided. If unavoidable, external pipework should be kept as short as possible (less than 3 metres) and 32mm waste pipe used to minimise the risk of ice blocking the pipe in freezing conditions.

The number of bends, fittings and joints on external pipes should be kept to a minimum to reduce the risk of trapping condensate.

### NOTE

For boiler installed in an unheated area such as an outhouse or garage, all condensate pipework should be considered as an 'external'.

## 6.5. Condensate Soakaway

To keep external pipework to a minimum, locate the soakaway as close as possible to the boiler but ensure it is at least 1 metre from building foundations and away from other services, e.g. gas, electricity, or water.

The condensate pipe may be run above or below ground level and can enter either the top or side of the soakaway tube. Refer to Figure 6-1.

Ensure that the drainage holes in the soakaway tube face away from the building.

Backfill the soakaway tube and the hole around it with 10mm limestone chippings.

Only use a soakaway where the soil is porous and drains easily. Do not use in clay soils or where the soil is poorly drained.

### CAUTION

Any damage due to condensate backing up into the boiler due to a high water table, in the case of a soakaway, or flooded drains when the condensate disposal is via a gully or soil stack, is not covered by the Grant product warranty.

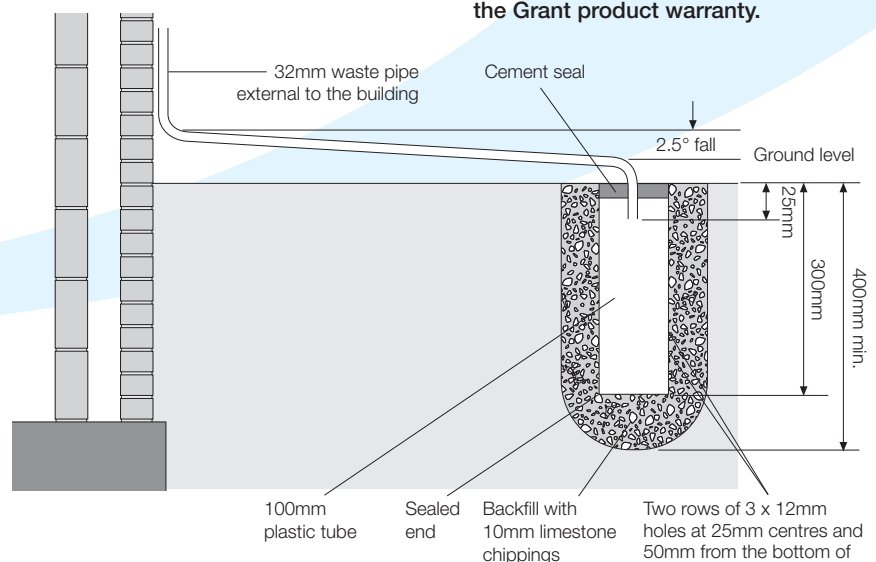

Figure 6-1: Purpose made condensate soakaway

### 6.6. Condensate Trap

Grant Condensing Wall-hung boilers are supplied with a factory-fitted condensate trap to provide the required 75mm water seal in the condensate discharge pipe from the boiler.

This trap incorporates a float (which will create a seal when the trap is empty) and an overflow warning outlet (fitted with a plastic sealing cap), See Figure 6-3.



**Figure 6-2:** Condensate trap location in-situ

The trap is factory-fitted inside the boiler casing – mounted on the outlet of the condensing heat exchanger - in an accessible position to allow for routine maintenance.

A 'push-fit' elbow connects the outlet of the condensing heat exchanger to the trap inlet. Ensure the elbow is fully pushed onto the 'top hat' inlet connector of the trap.

With the trap fitted inside the boiler casing, the sealing cap **must** be fitted.



**Figure 6-3:** Condensate trap

### 6.7. Condensate Disposal Pipework

The boiler is supplied with a flexible plastic condensate disposal pipe, factory-fitted to the outlet of the trap.

This flexible discharge pipe must be routed through the boiler to exit via one of the pre-cut 'knock-outs' in the bottom flange of the boiler back panel - at the right rear of the bottom casing.

Push out the 'knock-out' from the hole taking care not to distort the back panel flange.

The outlet end of this flexible pipe will accept 21.5mm OD to 23mm OD Polypropylene overflow pipe for connection of the condensate discharge pipe below the boiler.

#### NOTE

When connecting plastic discharge pipe, ensure that the pipe is **fully** pushed into the outlet end connector on the flexible pipe to prevent the possibility of leakage.

### 6.8 Inspection and Cleaning of Trap

The trap **must** be checked at regular intervals (e.g. on every annual service) and cleaned as necessary to ensure that it is clear and able to operate.

#### NOTE

The bottom bowl is sealed to the trap body and cannot be removed.

To inspect and clean the trap

1. Disconnect and remove snorkel tube to gain access to trap.
2. Leave inlet connector fitted to connecting elbow.
3. Unscrew the inlet connection nut.
4. Separate trap from the 'top hat' inlet connector and nut.
5. Unscrew outlet connection nut, disconnect disposal pipe from trap.
6. Remove trap from boiler.
7. Remove float from trap – clean if necessary.
8. Inspect inside of trap and clean as necessary.
9. Re-assemble trap, re-fit to boiler and re-connect inlet connection. Ensure that elbow is fully pushed onto the 'top hat' inlet connector and disposal pipe is correctly connected to trap outlet.

#### CAUTION

Failure to regularly check and clean the condensate trap may result in damage to the boiler and will not be covered by the Product Warranty.

# 7 Electrical

The Condensing boiler requires a 230/240 V ~ 50 Hz supply. It must be protected by a 5 Amp fuse.

Figure 7-6 is the wiring diagrams for the CONDENSING Wall Hung boiler.



**The Condensing boiler contains electrical switching equipment and must be earthed.**

The supply must be fused at 5 Amp and there must only be one common isolator for the boiler and control system, providing complete electrical isolation.

A fused double pole switch or a fused three pin plug and shuttered outlet socket must be used for the connection.

The power supply cable should be at least 0.75mm<sup>2</sup> PVC as specified in BS 6500, Table 16.

All the wiring and supplementary earth bonding external to the boiler must be in accordance with the current I.E.E. Wiring Regulations.

Any room thermostat or frost thermostat used with the Condensing boiler must be suitable for use on mains voltage.

In the event of an electrical fault after installation of the boiler, the following electrical system checks must be carried out:

- Short circuit
- Polarity
- Earth continuity
- Resistance to earth

## 7.1 Connecting the Power Supply

It is recommended that the boiler should be connected to a switched mains power supply from a programmer or control system. A three core cable is required to connect the boiler terminal block to the live supply. Refer to Figures 7-1 to 7-4 for typical control system wiring diagrams.



**When wiring in the supply cable to the boiler, allow sufficient cable length so that the control panel can be hooked to the top panel of the case during the service operation.**

The procedure is:

1. Remove the lower and upper front panels, if they have not already been removed.
  2. Remove the top of the control panel or the wiring cover (on Kitchen models) and open the cable clamp.
  3. Route the supply cable through the hole in the rear panel (using the grommet supplied) up to the control panel, pass it through the cable clamp and connect to the boiler terminal block as follows:
    - Brown to live (terminal 1)
    - Blue to mains neutral (terminal 2)
    - Green/Yellow to mains earth (terminal 3)
- Tighten cable clamp
  - Refit panels

## 7.2 Frost Protection

For additional protection of either the entire heating system, or the boiler and localised pipework, it is recommended that a frost thermostat be installed.

Refer to Section 7.3 for connection details.

To protect the heating system, the frost thermostat should be sited within the house in such a place that it can detect any rise and fall in the ambient air temperature, i.e. in a room with a radiator.

Where the frost thermostat is installed outside the house (to protect a boiler installed in an external boiler room or garage) or in an attic, it is recommended that it be used in conjunction with a pipe thermostat to avoid unnecessary and wasteful overheating of the property. The pipe thermostat should be located on the boiler return pipe, and set to operate at 25°C. Refer to Section 7.3 for connection details.

### 7.3 Control System Wiring Diagrams

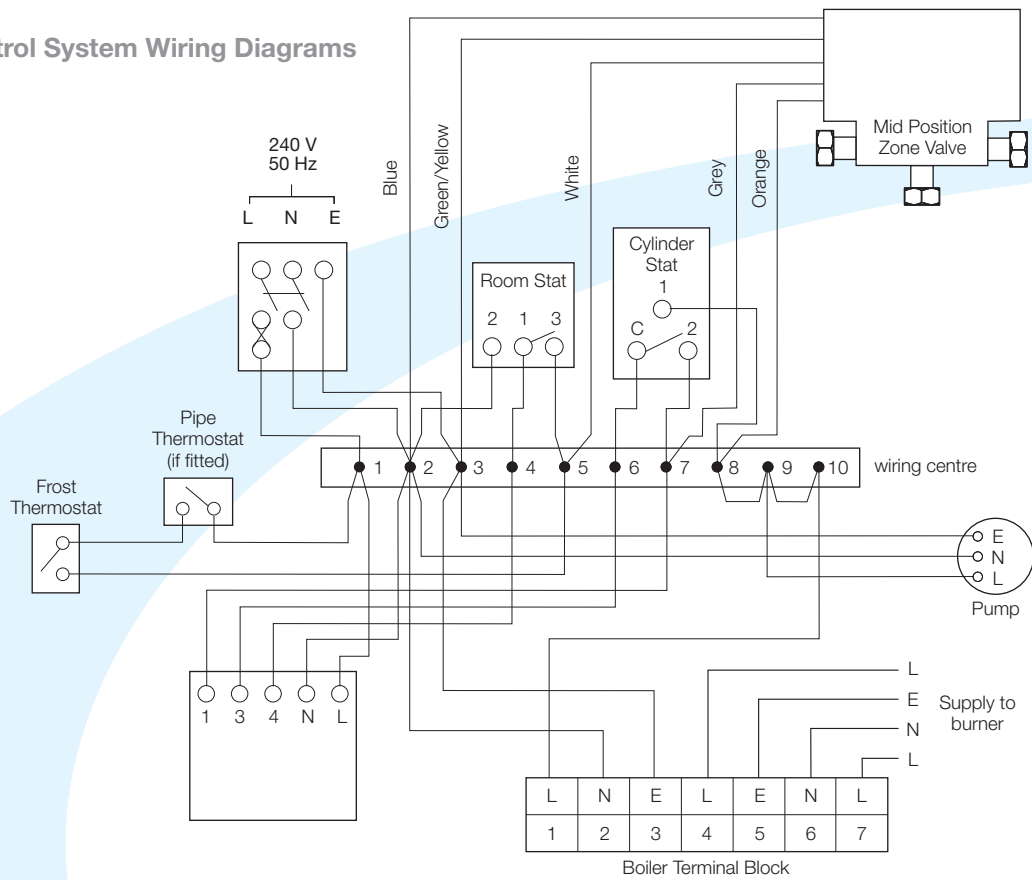

Figure 7-1: Models with 3-port valve control system

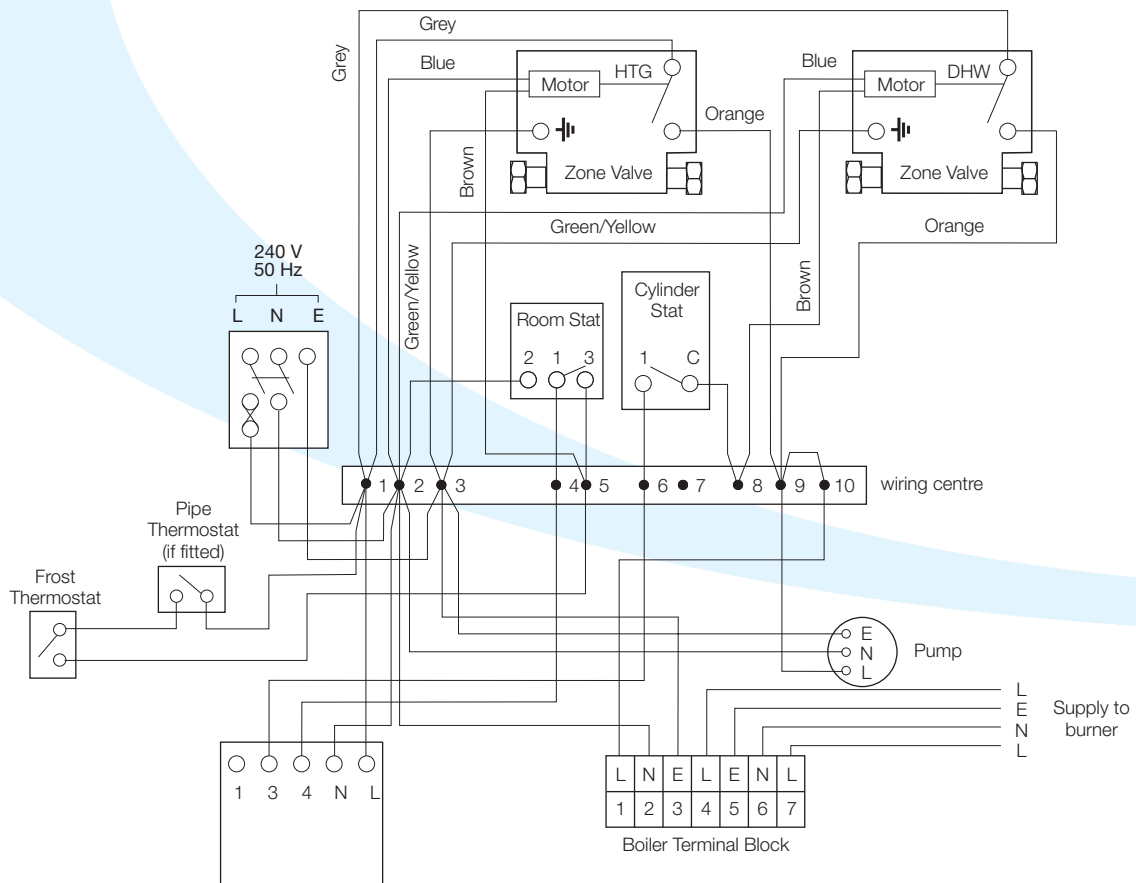

Figure 7-2: Models with 2 X 2-port control system

### 7.4 Boiler Control Panel Wiring Diagrams

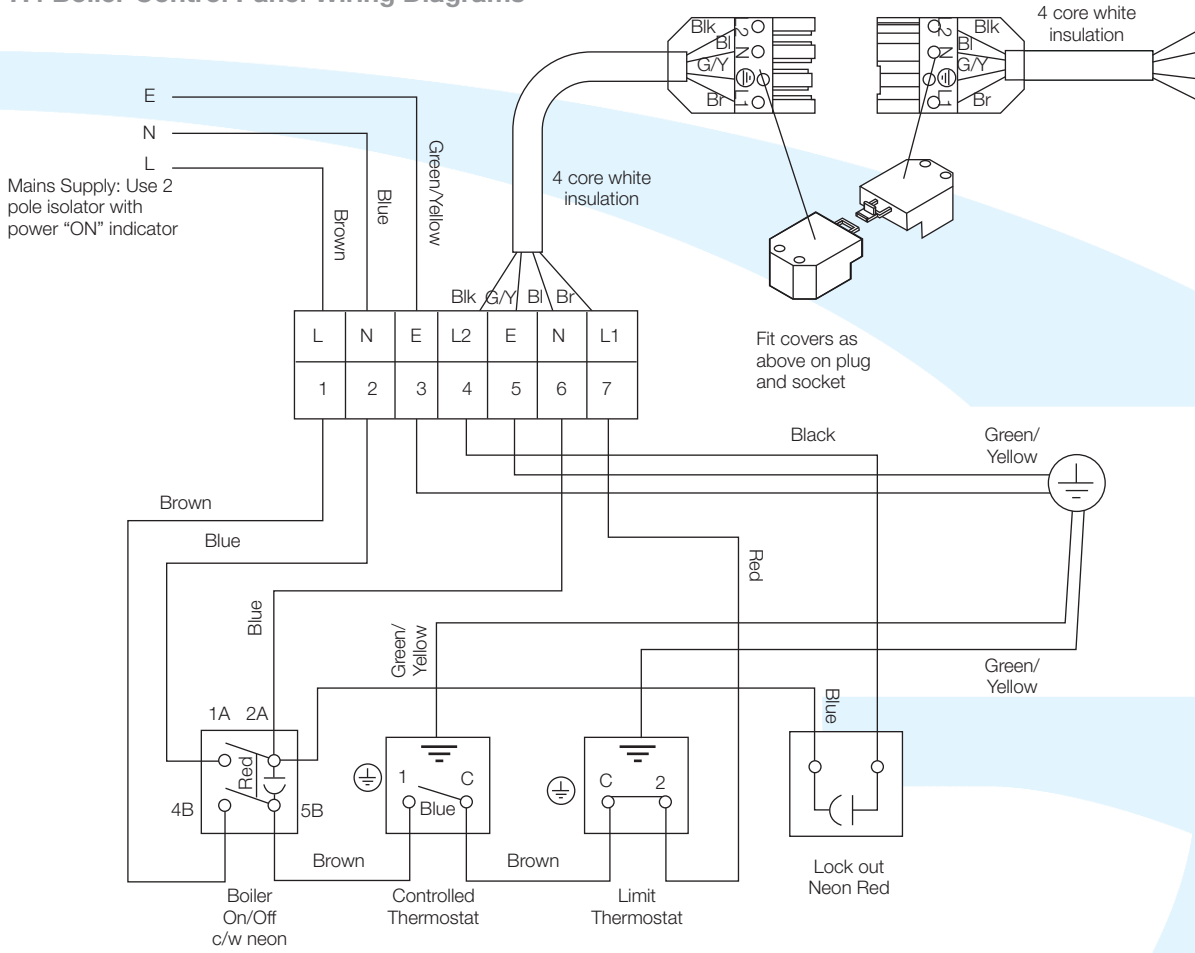

Figure 7-6: Wiring Diagram – Indoor models

# 8 Flue System and Air Supply

## 8.1 Air Supply

A sufficient permanent air supply to the boiler should be provided for the following reasons:

- For proper combustion of fuel and effective discharge of combustion products to the open air.
- For the ventilation of any confined space in which the boiler is installed to prevent overheating of the boiler any equipment in and near the boiler.

It should be both the designer's and installer's concern that the air required for these functions be introduced so as to cause as little discomfort as possible to the building occupants and thus to offer them the least temptation to obstruct the ventilators.

Further details may be obtained from BS 5410:1:1997.

### **!** NOTE

**For a boiler fitted in a compartment, which is ventilated as shown, no additional allowance is necessary.**

Open flue - Extract fans, where needed, should be in accordance with Section 4.4 in BS 5410 Part 1 1997.

All ventilation areas given are for domestic applications. For all other cases refer to BS 5410 Part 2 1978.

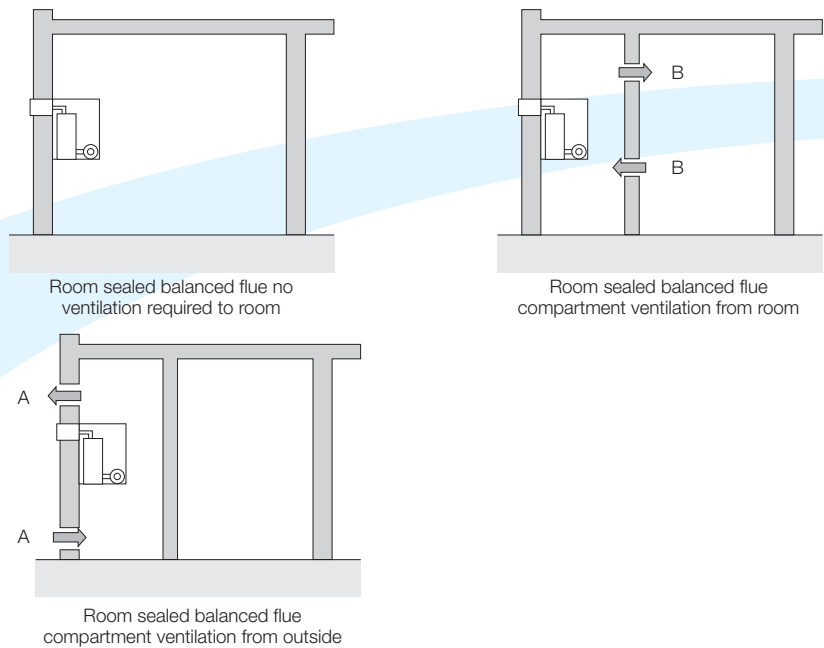

Figure 8-1: Air supply for room sealed balanced flue boilers

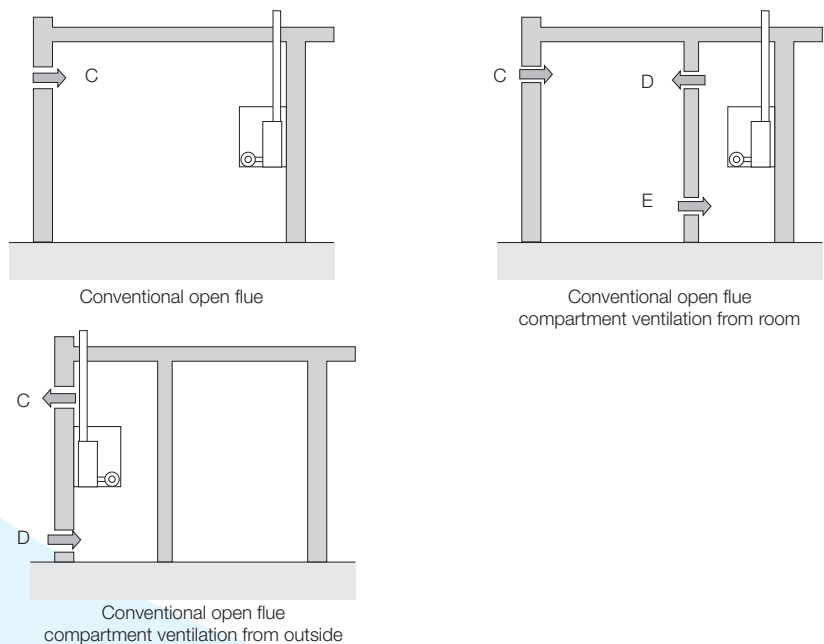

Figure 8-2: Air supply for conventional flue boilers

Condensing Wall-hung boilers - Ventilation areas				
Output	40/55 kW		55/70 kW	
Area	cm <sup>2</sup>	in <sup>2</sup>	cm <sup>2</sup>	in <sup>2</sup>
Vent A	83	13	116	18
Vent B	165	26	231	36
Vent C	83	13	116	18
Vent D	165	26	231	36
Vent E	248	38	347	54



## 8.2 Conventional Flue Systems

### NOTE

**Under no circumstances can Grant Condensing boilers be installed with existing flue systems. Only flue systems and components suitable for wet flues should be used.**

**Failure to install the correct type of flue system will invalidate the warranty.**

Grant condensing boilers have high operating efficiencies and low flue gas temperatures. Care must be taken to ensure the flue system is suitable for the very low flue gas temperatures and condensate in the flue gases.

Suitable conventional flue systems are available from Grant Ireland.

The flue must terminate in a down draught free area, i.e. at least 600mm above the point of exit through the roof or preferably above the ridge level.

The condensate may be allowed to run back into the boiler. A condensate drain at the base of the flue system is not required.

The high level flue terminal must be at least 600mm from any opening into the building, and 600mm above any vertical structure or wall less than a horizontal distance of 750mm from the terminal.

**If an existing chimney is to be used,** it must be lined with a smooth bore stainless steel liner suitable for use with oil fired condensing boilers. The top and bottom of the annular space must be sealed.

Grant recommends the use of the Grant 'Orange' flue system, specifically designed for the Condensing range of condensing boilers.

The internal flue liner diameter for all models is 100mm (4 in).

The maximum vertical height (from the top of the boiler to the terminal) for the 'Orange' system is 19 metres.

**If a rigid flue is used externally,** it must be of the twin-wall type incorporating seals at all joints, constructed with a stainless steel inner skin and be suitably insulated and weatherproofed. The internal flue diameter for a rigid flue for all models is 100mm (4 inches).

### NOTE

**As no flue adaptor is supplied with the boiler, in order to correctly connect the hybrid system, it will be necessary to purchase the Grant CF adaptor kit (Ref. CFA15/70).**

If required, it is possible to use the white painted single-wall straight flue extensions, adjustable extensions and elbows from the Grant 'Orange' system for the internal section of the flue system. These components can be fitted between the boiler connector and flue adaptor. The flue adaptor, to which the external twin-wall 'Green' flue components are connected, can therefore be situated just before the flue system passes through the wall.

### NOTE

**Grant 'Orange' system single-wall flue components must not be used externally.**

The maximum vertical height (from the top of the boiler to the terminal) for the system is 8 metres.

Grant 'Green' twin-wall flue is recommended for externally run flues to reduce the possibility of the condensate freezing in the flue.

No part of any flue system should be made of an asbestos material; aluminium must not be used in any part of the flue. Only stainless steel flue components should be used.

If the draught conditions are satisfactory, the flue should terminate with a standard cowl.

Refer to the locally applicable Building Regulations, BS 5410:1 and OFTEC Installation Requirements (OFTEC Books 2 and 3) for further guidance on conventional flue systems.

### CAUTION

**It is important to ensure that the flue system is sealed and that condensate cannot escape. Up to 1.5 l/h of condensate can be produced in a conventional flue system.**

Use only flue systems suitable for oil fired condensing boilers.

Do not use fire cement. The use of high temperature silicone sealants is recommended.

### Flue Lining Kits

#### Grant EZ-Fit Flexi Pack conventional flue system (Orange System)

A range of Flexi pack conventional flue lining kits are available from Grant Ireland. The packs have been specifically produced for Grant Condensing oil fired condensing boilers.

The pack includes a terminal/top plate/flexi flue adaptor, stainless steel smooth bore flexible flue liner, a rigid to flexi adaptor and a boiler flue connector.

### Extensions

A range of white powder coated single wall extensions are available to connect the boiler to the flexible liner.

The nominal diameter of the extensions is 100mm.

Extensions are supplied with locking bands.

### Flue extensions cannot be cut.

Also available are:

- An adjustable extension
- 45° elbow



The rigid flue between the boiler and flexible flue liner should incorporate an adjustable section to allow inspection and cleaning of the flue system.

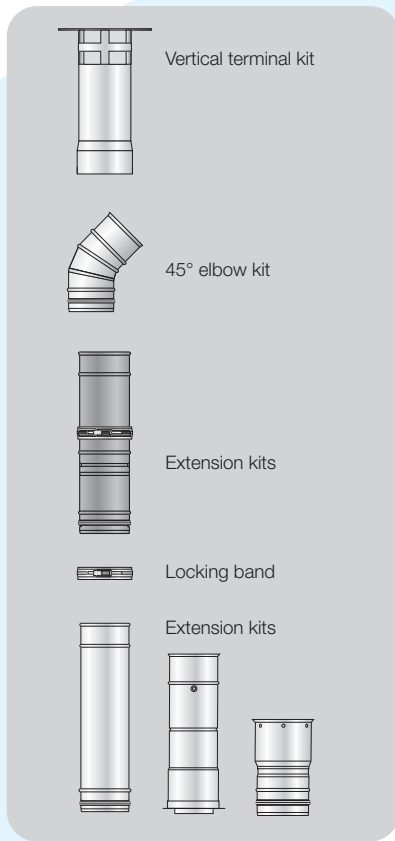

Figure 8-3: Orange system extensions

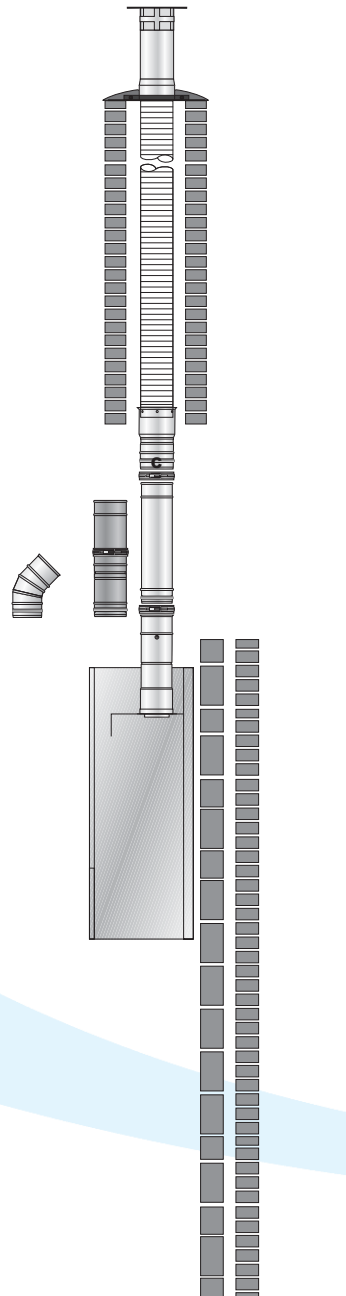

Figure 8-4: Grant Orange flue system in a typical brick chimney

### 8.3 Connecting a Conventional Flue

1. Unscrew and remove top casing panel.
2. Push out the pre-cut blanking panel.

If the Grant 'Orange' flue system is being used, follow the instructions supplied with the flue kit.

If the Grant 'Green' system (100mm rigid twin wall flue) is to be fitted to the boiler then the Grant CF adaptor kit (Ref. CFA15/70) must be used – refer to Section 1.2.

To fit the adaptor kit, proceed as follows:

1. Fully screw the length of threaded studding (provided in the kit) into the nut located in the centre of the boiler flue outlet.
2. Fit the boiler connector (from the CF adaptor kit) over the threaded studding.
3. Position flange on to the neoprene gasket around the boiler flue outlet, ensuring that small spigot on the base of the connector is located in the hole in the centre of the neoprene gasket and that end of studding passes through the hole in the of the spacer bracket.

4. Fit the washer and wing nut provided onto end of threaded studding and secure the connector in position by tightening down on wing nut – as shown in Figure 9-6.

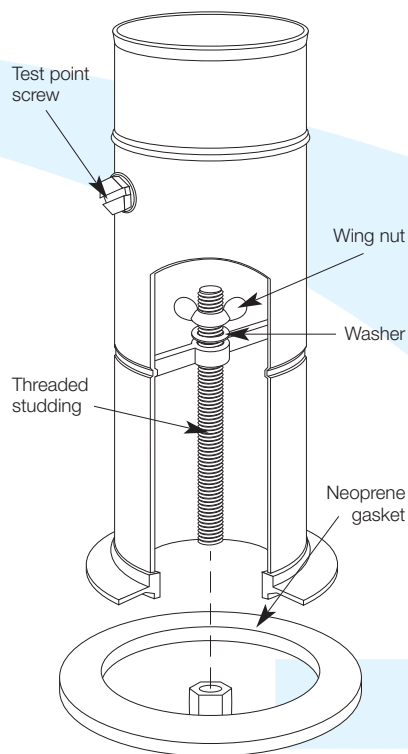

Figure 8-6: Boiler flue connector

5. Re-fit the top casing panel to the boiler – fitting it over the boiler connector.
6. Fit the flue adaptor (from the adaptor kit) into the boiler connector.

### NOTE

**Lubricate the seal on the adaptor using the lubricant provided before attempting to fit the flue adaptor.**

7. Fit the first section of flue into the flue adaptor and secure using the clamp band provided.
8. Assemble the remainder of the flue system as required, lubricating the seal on each component before fitting.

### 8.4 Balanced Flue Systems

Apart from a conventional flue, several balanced flue options are available for use with the Grant Condensing Wall Hung boilers. All are suitable for use with Class C2 kerosene.

### NOTE

**None of the flue sections in the following system can be cut.**

#### Low Level Horizontal Balanced Flue (Yellow system)

Available in either Short (for single thickness brick walls) and Standard kits.

Extensions are available which extend the flue by 225mm, 450mm or 675mm.

90° and 45° elbows are also available.

The maximum flue length - from the centre of the boiler flue outlet to the outer face of the wall - is 4 metres (with or without elbows included). No more than 2 x 45° or 1 x 90° elbow should be fitted per system.

The low level balanced flue (Yellow system) is supplied with a stainless steel guard. This must be fitted in all circumstances to prevent objects from entering the flue outlet.

The guard must be fitted centrally over the flue terminal and securely fixed to the wall.

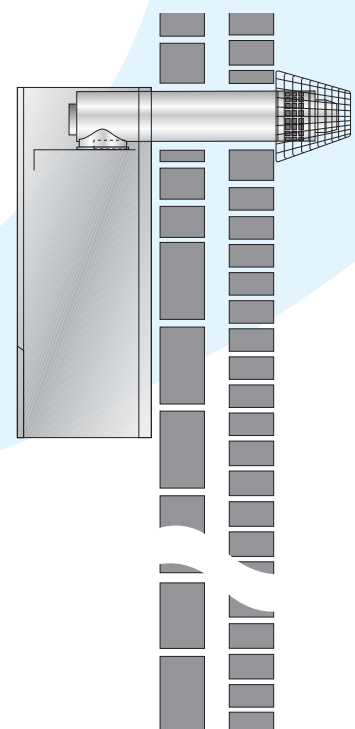

Figure 8-7: Low level balanced flue

### High Level Horizontal Balanced Flue (White system)

The High Level (horizontal) balanced flue (white system) allows the flue to rise vertically within the building before exiting through the wall horizontally.

The maximum flue length - from the top of the boiler flue outlet to the outer face of the wall - is 10 metres for all Condensing boilers.

The following items are additionally available:

- Extensions to extend the flue by 225mm, 450mm or 950mm.
- An adjustable extension of 275 to 450mm.
- A 45° elbow - No more than 6 x 45° elbows should be fitted per system. Each elbow reduces the overall maximum length of the system by 1 metre.

### Vertical Balanced Flue (White system)

Allows the flue to rise vertically from the boiler to exit through the roof.

The maximum flue length - from the top of the boiler flue outlet to the terminal - is 12 metres for all Condensing boilers.

The following items are additionally available:

- Extensions to extend the flue by 225mm, 450mm or 950mm.
- An adjustable extension of 275 to 450mm.
- A 45° elbow - No more than 6 x 45° elbows should be fitted per system. Each elbow reduces the overall maximum length of the system by 1 metre.

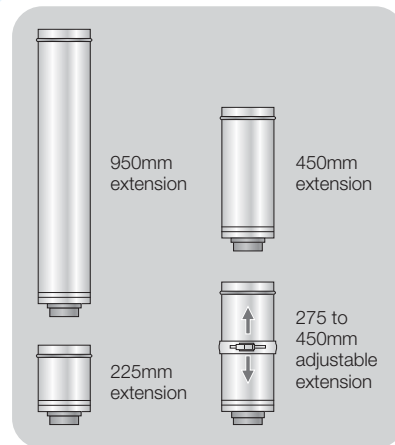

Figure 8-8: White system extensions

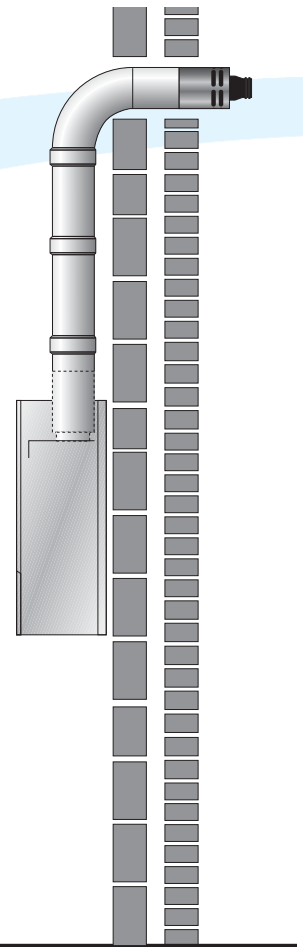

Figure 8-9: High level balanced flue

### White System Components

Item – for models up to 26 kW output	Part No.
High level flue kit – 1.2 metre	HL K01 50/90
Vertical flue kit – 3 metre	VT K05 50/90
225mm extension	EXT K31 225/90
450mm extension	EXT K09 450/90
950mm extension	EXT K11 950/90
275-450mm adjustable extension	EXT K13 ADJ/90
45°elbow	ELB K21 45/90
Pitched roof flashing – aluminium (for VT K05 50/90)	VT MF 90
Pitched roof flashing – lead (for VT K05 50/90)	VT K25 P90
Flat roof flashing – aluminium (for VT K05 50/90)	VT K27 F90
Wall bracket	BRK 29 90

### External Balanced Flue (Green system)

Where it is not practical to use a low level (Yellow system) or internal high level/vertical (White system) balanced flue, the boiler can be fitted with an external vertical/high level flue (Green system).

See Figure 9-11.

The Starter kit fits to the boiler in the same way as a low level balanced flue (Yellow system) and the external Tee allows the connection of a twin wall insulated flue pipe and a combustion air inlet - providing a room sealed flue system.

The external system can terminate at either high level or vertically (above roof level) as required.

See Figure 9-11.

The minimum dimensions for locating the terminal from building features (windows, doors, etc.) are shown in Figure 9-12.

The terminal must be positioned so as to avoid products of combustion accumulating in stagnant pockets around the buildings or entering into buildings. Care should be taken that the plume from condensed flue gases does not cause a nuisance.

The following external flue (Green system) components are available from Grant Ireland:

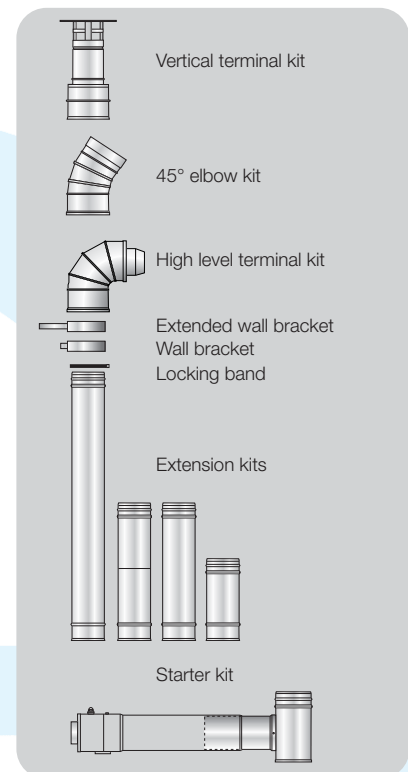
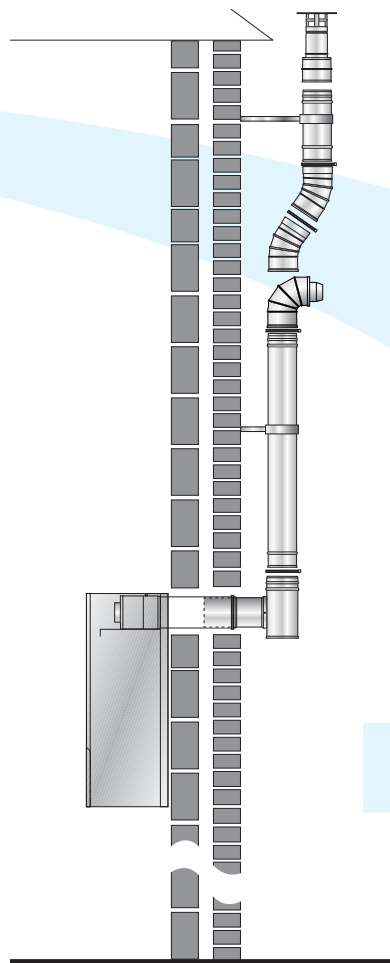

**Figure 8-11: External balanced flue (Green system)**

Green System Components	
Item – for models up to 26 kW output	Part No.
Starter kit – standard	GK90
Starter kit – short	GK90S
150mm extension	GX150/90
250mm extension	GX250/90
450mm extension	GX450/90
950mm extension	GX950/90
195-270mm adjustable extension	GXA250/90
45° elbow	GE45/90
High level terminal	GTH90
Vertical terminal	GTV90
Wall bracket – standard	GWB90
Wall bracket – extended	GEB90

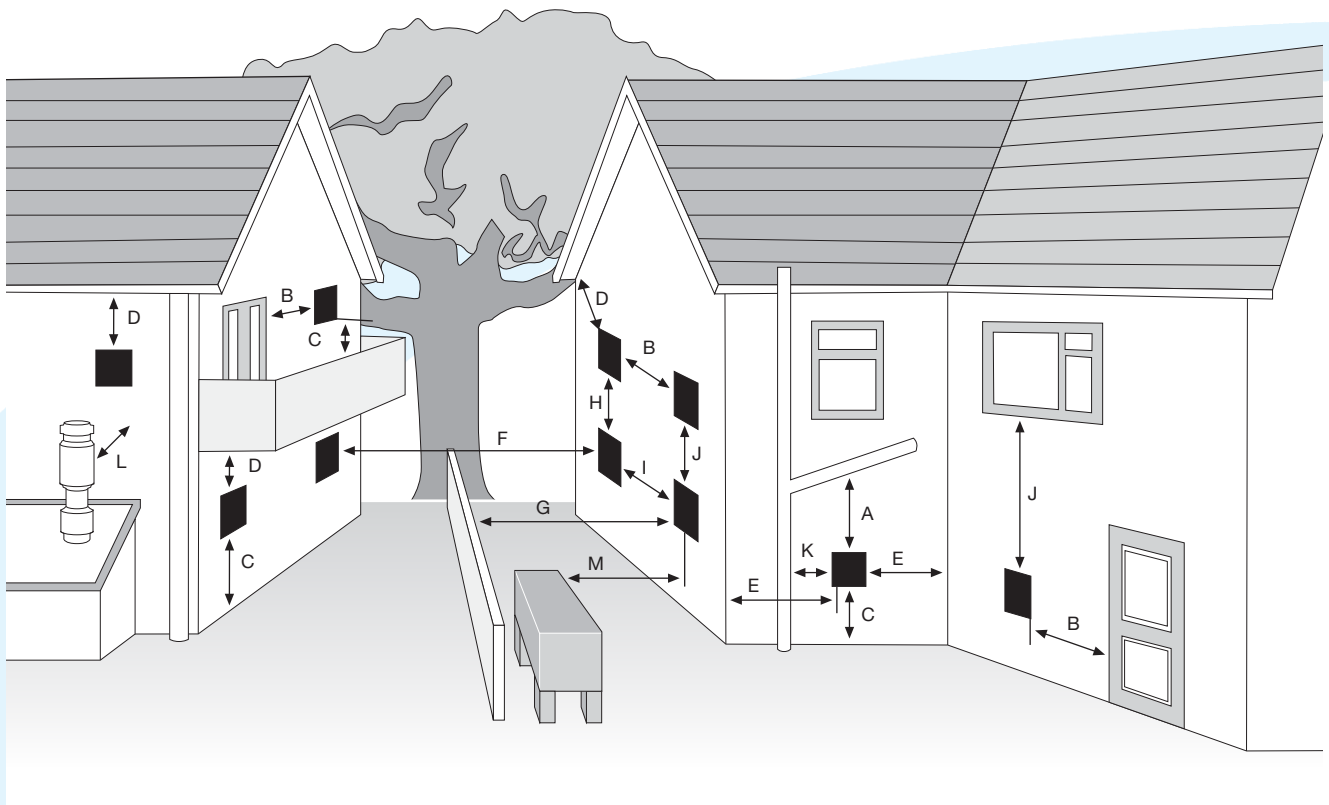

Figure 8-12: Clearances for Balanced flue terminals

Terminal position	Min. distance (mm)
A Below a gutter or sanitary pipework	600*
B Horizontal from an opening, air brick or window	600
C Above ground or balcony level	300
D Below eaves or balcony	600*
E From an internal or external corner	300
F From a terminal facing the terminal	1200
G From a surface facing the terminal	600
H Vertical from terminals on the same wall	1500
I Horizontal from terminals on the same wall	750**
J Below an opening, air brick, window, etc.	600
K From vertical sanitary pipework	300
L Vertical flue from wall	750
M From an oil storage tank	1800

**Notes:**

\* 75mm with protection.

\*\* Only applies if one or both terminals are balanced flues.

Distances measured to rim of terminal.

Clearances recommended by Grant Engineering (Ireland) Limited in accordance with British Standards and Building Regulations.

**NOTE**

1. An opening means an openable element, such as an openable window, or a permanent opening such as a permanently open air vent.
2. Notwithstanding the dimensions given, a terminal should be at least 300mm from combustible material, e.g. a window frame.
3. A way of providing protection of combustible material would be to fit a heat shield at least 750mm wide.

### 8.5 Prepare the Wall

If the boiler is to be used with a low level balanced flue (Yellow system) make the hole in the wall for the flue as shown in Figure 9-13.

#### NOTE

Dimension B given in Figure 9-13 includes an extra 10mm over the size of the terminal to provide clearance for fitting.

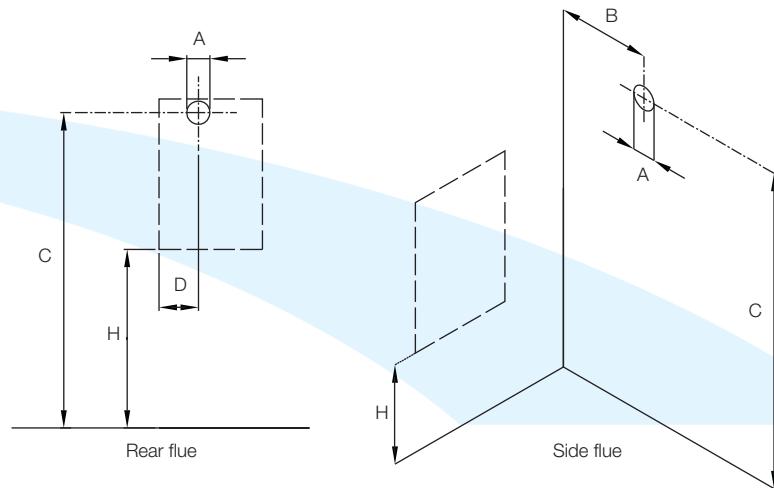

Low level balanced flue - Yellow system  
External flue starter kit - Green system

Figure 8-13: Flue hole dimensions and position for low level systems

Dimension (mm)			
A dia	B	C	D
127	112	H + 765*	220

\*H is the height from the floor to underside of boiler casing

### 8.6 High Level and Vertical Balanced Flue

If the boiler is to be used with the high level balanced flue (White system) make the hole in the wall as shown in Figure 9-14.

#### NOTE

Dimension B given in Figure 9-14 includes an extra 10mm over the size of the terminal to provide clearance for fitting.

Fitting instructions for the high level balanced flue and vertical balanced flue are supplied with the flue kits.

#### Adjustable Extensions

The adjustable extensions are telescopic. The wall terminal section is adjustable and is suitable for a wall thickness of 215mm to 450mm.

Simply adjust to the required length using a twisting motion. The outer pipes must overlap by a minimum of 25mm.

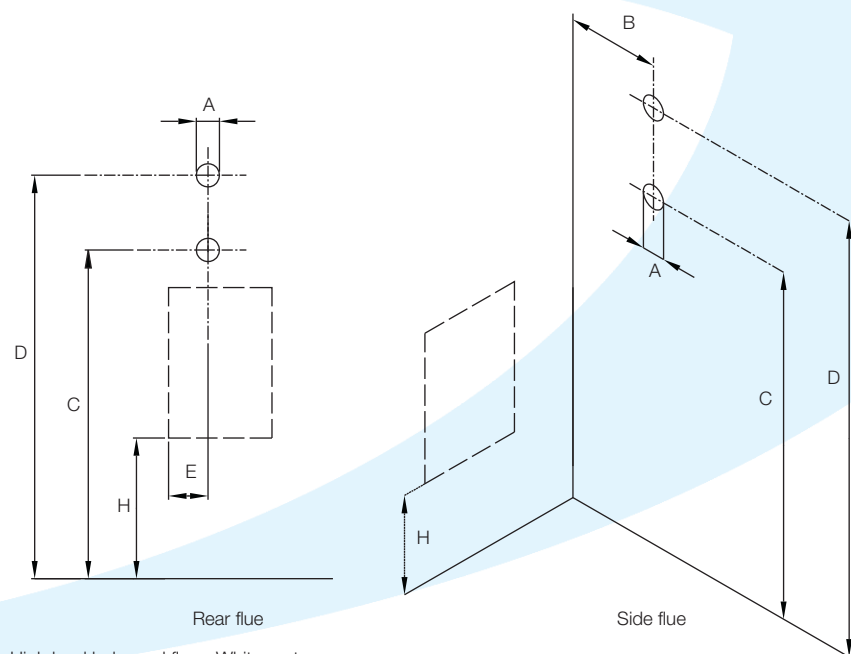

High level balanced flue - White system

Figure 8-14: Flue hole dimensions and position for high level system

Dimension (mm)					
A dia	B	C min	D min	D max	E
175	112	H + 1207*	H + 1707*	H + 2107*	220

\*H is the height from the floor to underside of boiler casing

# 9 Commissioning

It is important that the following commissioning procedure is carried out to ensure safe and efficient operation of the boiler.

To access the controls, open the lower front panel by pulling it down as shown in Figure 10-1.

The controls are shown in Figure 10-2.

## 9.1 Before Switching On

1. Check that the turbulators are in position and that the ends are vertical.
2. Check that the baffles are in position and that the cleaning cover is correctly fitted and a good seal made. See Section 4.5.
3. Check that the water system has been vented and there are no leaks.

4. Ensure the automatic air vent on the condensing heat exchanger is open.
5. Check that all fuel line valves are open.
6. Connect a combined vent manifold and pressure gauge to the pressure gauge connection port on the oil pump. See Fig. 3-4. Open the vent screw on the vent manifold to vent the supply while the pump is running.
7. Set the boiler On/Off switch to Off. Check that all system controls are calling for heat and turn the boiler thermostat to maximum.



Figure 9-1: Boiler lower front panel in down position



Figure 9-2: Boiler controls

## 9.2 Switching on

1. Switch on the electricity supply.
2. Set the boiler On/Off switch to On. The burner fan should start and the burner should light within about 12 seconds. If the burner does not light and the 'Lock-out' reset button lights, wait for about 1 minute, then press the reset button to restart the ignition process. This procedure may have to be repeated several times during first lighting.
3. With the burner alight, check the fuel pressure.
4. Refer to the Technical Information, Section 2.3.
5. Adjust the pressure if necessary - see Fig. 3-4. (Note that the 'Mains On' neon lights lit when the boiler is switched on does not necessarily indicate the burner is firing. It merely indicates that the power is connected).

## ! NOTE

It is important that the oil pressure is correctly set.

6. Operate the boiler until it reaches normal operating temperature. Check oil supply/return pipe for leaks, rectifying where necessary.
7. Check the operation of the boiler thermostat. Ensure that by turning it anticlockwise it switches the burner off.
8. With the burner alight, re-check the fuel pressure and re-adjust if necessary. Turn the boiler off, remove the pressure gauge and replace the plug in the pump.
9. Ensure that there are no oil leaks and the flexible air tube is connected to the burner (balanced flue models).



### 9.3 Running the Boiler

1. Re-light the boiler and allow it to run for at least 20 minutes.
2. Check the smoke number, if satisfactory check the CO<sub>2</sub>. Set the CO<sub>2</sub> to the value given in Section 2.3 for the boiler concerned.
3. Turn the air control knob on the burner to adjust the burner air damper (see Figure 10-3) as required. Turning the knob anti-clockwise closes the damper and increases CO<sub>2</sub> level. Turning the knob clockwise opens the damper and reduces CO<sub>2</sub> level.
4. Re-check the smoke number if the damper has been moved. Under no circumstances must the smoke number be above 1.

#### ! NOTE

It is important that the air damper is correctly set.

5. Check the flue gas temperature.

Check that both the boiler overheat and boiler control thermostat bulbs are correctly located in their respective pockets. For location of thermostat pockets, refer to Figure 10-3.

6. Also check the condition of both thermostat capillaries, i.e. that they are not damaged, broken or kinked, and that they are not trapped or crushed between any internal boiler components.



Figure 9-3: Thermostat phial position

### 9.4 Balancing the System

1. When the boiler has been adjusted and is running satisfactorily, balance the central heating system by adjusting the radiator lock shield valves. Start with the radiator nearest the boiler and adjust the valves to achieve the required temperature drop across each radiator. If thermostatic radiator valves have been installed, check the system by-pass.
2. Switch off the boiler.

### 9.5 Completion

1. With the system hot, check again for leaks, rectifying where necessary. Drain the system while it is hot to complete the flushing process. Refill and vent the system.
2. A suitable central heating system inhibitor must be added to protect the system against the effects of corrosion.

#### ! NOTE

After commissioning the boiler complete the **Commissioning Report** in the front of this manual and the **OFTEC CD/11 commissioning report**. Leave the top copy with the User and retain the carbon copy.

If the boiler is to be left in service with the User, set the controls, remote programmer and room thermostat to the User's requirements.

If the boiler is not to be handed over immediately, close the boiler fuel supply valve and switch off the electricity supply.

#### ! CAUTION

If there is any possibility of the boiler being left during frost conditions, then the boiler and system should be drained.

To allow the boiler to be commissioned and serviced correctly a combustion test point is provided on the front cleaning door.

The CO<sub>2</sub> and smoke test may all be carried out using this test point.

#### ! NOTE

The test point is not suitable for measuring boiler efficiency or conventional flue draught.

When using the test point on the cleaning cover note that the flue gas temperature reading will be higher than that measured in the flue thus resulting in an inaccurate efficiency reading. To obtain an accurate flue gas temperature and efficiency, the reading can be measured only outside through the low level flue terminal. For high level and vertical balanced flues the reading may be taken from the flue test point provided. Refer to Section 2.3.

For Conventional flue draught measurement and efficiency a test point is provided in the conventional flue adaptor.

# 10 Boiler Servicing

To ensure efficient operation of the boiler it is recommended that it is checked and serviced as necessary at regular intervals. The frequency of servicing will depend upon the particular installation conditions and usage, but in general once per year should be adequate.

Servicing and replacement of parts must only be carried out by a suitably qualified engineer.



## CAUTION

Details of every service should be entered in the Service Log, in the Boiler Handbook.

This information may be required to validate the Grant extended warranty.



## WARNING

Before starting any work on the boiler, or fuel supply please read the health and safety information given in Section 13.

### 10.1 Checking Before Servicing

The following sequential checks should be made before any servicing:

1. Check the flue terminal and ensure it is not blocked or damaged.
2. Run the boiler and check the operation of its controls.
3. Ensure that all water/fuel system connections and fittings are sound. Remake any joints and check the tightness of any fittings that may be leaking.
4. Refill, vent and re-pressurise the system as necessary.
5. Check that any ventilation openings are adequate and are clear.

6. Remove any sludge/water from the fuel tank by opening the sludge valve at the lower end of the tank.
7. With the fuel supply valve closed, clean/replace the filter element and clean the filter bowl.
8. Braided flexible fuel supply hoses as supplied with the boiler should be replaced annually when the boiler is serviced. If long-life hoses have been installed, these should be inspected annually. If in doubt replace the hoses. In any event, these hoses must be replaced every five years.



## WARNING

Before servicing, set the boiler On/Off switch to Off, isolate the electricity supply and close the fuel supply valve.

Allow the boiler to cool.

The data label on the front of the boiler will indicate the fuel used and the nozzle fitted.

### 10.2 Dismantling Prior to Servicing

The procedure for dismantling the boiler is as follows:

1. Remove the front panels.
2. Disconnect the flexible air tube from the burner.
3. Remove the burner fixing nut (top of mounting flange) and rotate the burner clockwise and withdraw the burner. The burner has a lug to fit over a bracket on the front of the combustion chamber to hold it while servicing takes place.



## NOTE

With two flexible hoses connected to the burner, identify (mark if necessary) which is the inlet and return if they are to be disconnected.

### 10.3 Cleaning the Boiler

The procedure for cleaning the boiler is as follows:

1. Remove the nuts and washers securing the front cleaning door and withdraw the door. Take care – it is heavy.
2. Remove the baffles as shown in Figure 11-1.



Figure 10-1: Removing the baffles

3. Remove all deposits from the baffle plates and all the boiler internal surfaces using a stiff brush and scraper if necessary.
4. Check the condition of the flue, clean as necessary.
5. Check the condition of the front cleaning door seal and replace if necessary.
6. Replace the baffles, ensuring they are correctly fitted.
7. Pull out the spiral turbulators from the heat exchanger tubes.
8. Clean the turbulators using a stiff brush.
9. Test the heat exchanger condensate drain by pouring water into one of the lower tubes and observe whether the water discharges from the 22mm condensate outlet. Replace the turbulators, ensuring the ends are vertical.

10. Replace the front cleaning door, ensuring the seal is in good condition and secure it in position with the nuts and washers previously removed. Tighten to form a seal.
11. Remove the condensate trap and check that it is not blocked and is operating correctly, i.e. the float is free to move. Clean the trap and float as required. Refer to Section 6.8.
12. Check that the boiler condensate outlet is unobstructed. Clean if necessary.

## NOTE

The condensate trap and condensate outlet must be checked on every service and cleaned as necessary.

### 10.4 Cleaning the Burner

The procedure is:

1. Combustion head - Loosen the two screws securing the combustion head and withdraw the head.
2. Clean the combustion head.
3. Inspect the ignition electrodes - Loosen the electrode clamp screw and withdraw the electrode assembly. Wipe clean and check for any cracks in the ceramic insulation. Replace if necessary.
4. Nozzle - The nozzle should be replaced on an annual service - Check that the nozzle size and type are correct, refer to table in Section 3.3 and boiler data label.
5. Do **not** attempt to clean the nozzle.
6. Remove the nozzle using a good fitting spanner (16mm).

## CAUTION

The use of an ill-fitting spanner will damage the nozzle and could lead to an incorrect flame pattern.

7. Always check the electrode settings after replacing the nozzle, see Figure 11-2.
8. Re-connect the HT leads to the electrodes and refit the combustion head.

### All models

**Photocell** - The photocell is a push-fit in the burner body. Carefully pull out the photocell to clean.

**Burner fan** - Remove the air intake from the burner. Check, inspect and clean the fan as required. Replace the cover.

**Pump filter** - Remove the four screws securing the pump end cover. Remove the filter and wash in kerosene. Replace the filter and end cover, ensure the 'O' ring is in position.

Re-assemble in reverse order.

## WARNING

To ensure safe and efficient operation of the boiler it is important that re-commissioning is carried out, especially combustion checks (CO<sub>2</sub> level, flue gas temperature and smoke number) after the boiler has been serviced.

Refer to the Commissioning instructions in Section 10.

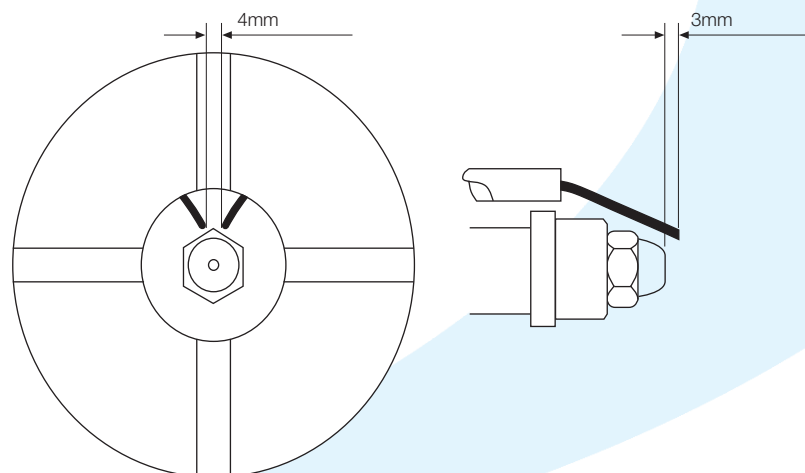

Figure 10-2: Electrodes showing setting

# 11 Fault Finding

## 11.1 Burner Fault Finding Chart

### 1. Burner fails to start – no flame – no lock out

Symptoms	Possible Causes	Actions
Motor fails to run	No electrical supply to boiler	Check On/Off switch is On - mains neon is lit
Lock-out light not lit	Fuse has blown	Check or replace fuse If fuse has blown - check reason for failure
	Boiler thermostat not calling	Adjust boiler thermostat to call for heat
	Heating controls are not calling	Adjust programmer & room thermostat to call
	Overheat thermostat has operated	Check and reset overheat thermostat if required If operated - check reason for operation
	No power to burner	Check for 230V at control box mains terminals
	Control box faulty	Replace faulty control box

### 2. Burner fails to start – no flame – goes to lock out

Symptoms	Possible Causes	Actions
Motor fails to run	No power to burner motor	Check for 230V at motor plug terminals
Burner lock-out	Burner motor capacitor faulty	Check and replace if necessary
	Burner motor faulty	Replace burner motor
	Burner motor stalled	
	Seized oil pump	Check and replace faulty oil pump

### 3. Burner starts – no flame – goes to lock out

Symptoms	Possible Causes	Actions
Motor runs	Flame instability	
Burner pre-purges	Carbon/soot on blast tube	Clean blast tube
Burner does not fire	No oil pressure	Check pump drive coupling - replace if failed
Burner lock-out	Low oil pressure	Check oil pump pressure is correct
	Excessive combustion air	Adjust air damper setting
	Excessive flue draught - CF only	Rectify condition (draught stabiliser required?)
	False light	Check photocell is not sensing ambient light
	No ignition spark	Check HT lead connections are sound Check ignition electrode gap is correct Check for 230V at ignition transformer Check transformer - replace if faulty
	No oil at nozzle	Check for sufficient fuel in tank Check fire valve has not tripped Check all oil supply valves are open Check oil line & pump is not airlocked Check operation of solenoid valve Check pump drive coupling - replace if failed Check fuel pump - replace if seized
	Restriction in oil supply	Check filters, valves and oil lines and rectify
	Fuel contamination (water in tank)	Check tank, filters, oil line for water

### 4. Burner fires – goes to lock out

Symptoms	Possible Causes	Actions
Motor runs	Flame instability	
Burner pre-purges	Carbon/soot on blast tube	Clean blast tube
Burner fires	Fuel contamination (water in tank)	Check tank, filters, oil line for water
Burner lock-out	Low oil pressure	Check oil pump pressure - reset if necessary
	Excessive combustion air	Adjust air damper setting
	Excessive flue draught - CF only	Rectify condition
	Photocell not sensing light	Check photocell is clean and unobstructed
	Photocell failed	Replace faulty photocell
	Defective nozzle	Replace nozzle

### 5. Delayed ignition – burner starts violently

Symptoms	Possible Causes	Actions
Burner pulsates on start-up	Excessive combustion air	Re-commission burner - adjust air setting
	Low oil pressure	Check and re-commission burner
	Partially blocked nozzle	Replace nozzle
	Fuel contamination (water in tank)	Check tank, filters, oil line for water
	Fan slipping on shaft	Check and re-tighten
	Pump coupling loose or worn	Check and replace
Burner starts violently	Delayed ignition	Check electrode settings
		Check electrodes for damage
		Check HT lead connections are sound
		Check HT leads for damage or arcing

### 6. Burner cycles on and off

Symptoms	Possible Causes	Actions
Burner firing	Restriction in oil supply	Check filters, valves and oil lines and rectify
Burner stops firing	Fuel contamination (water in tank)	Check tank, filters, oil line for water
Pre-purge starts	Partially blocked nozzle	Replace nozzle
Burner fires	Vitiated combustion air - BF only	Disconnect snorkel tube and check operation
Burner stops firing		Check flue terminal for obstructions and rectify
		Check flue system for leaks and rectify
	Boiler thermostat hunting	Replace faulty thermostat

## 11.2 Boiler Fault Finding

Always isolate the electricity supply to the boiler before working on the boiler.

Fault	Remedies
<b>Boiler will not start:</b>	
1 No fuel supply.	Ensure that an adequate supply of fuel is available and that the fuel supply valve is open. Check the condition of the fuel filter, clean if necessary. Ensure fuel supply is reaching burner and vent pump.
2 No electricity supply.	Ensure electricity supply to the boiler is switched on and that all controls are calling for heat. Ensure that the overheat thermostat has not tripped, reset if necessary. Check that a mains supply is present at the burner terminal block. If not, check the boiler and overheat thermostat.
3 Burner not starting - fuel and electricity supplies present.	Press the reset button on the burner if lit on the control box. Refer to burner fault finding flow diagram.
4 Burner lights but goes to 'lock-out'.	If the flame is unstable, check the combustion settings. Refer to burner fault finding flow diagram.
<b>Boiler works but:</b>	
5 Visible smoke from flue or high smoke number.	Insufficient air supply – check the air damper setting and the condition of the fan. Check room ventilation is adequate. See Section 9.1. Check the nozzle size and type. Fuel pressure may be too high – check and adjust.
6 Burner pulsates.	Insufficient air supply – check the air damper setting and the condition of the fan. Check room ventilation is adequate, See Section 9.1. Check the nozzle size and type.
7 Flame slow to stabilise during start up.	Insufficient air supply – check the air damper setting and the condition of the fan. Check room ventilation is adequate, See Section 9.1. Check the nozzle size and type. Fuel pressure may be too low – check and adjust. Insufficient draught – clean boiler heat exchanger and check condition of flue.
8 Water temperature low.	Undersize nozzle and/or low fuel pressure. Check condition of boiler heat exchanger and clean if necessary. Check the boiler thermostat. Check the combustion settings. Check the condition of the fuel filter.
9 Boiler operating on overheat thermostat.	Faulty boiler thermostat. No circulation, check circulating pump. Check for air lock.
10 Fumes and puffing during starting (conventional flue).	Check the condition of the chimney, ensure it is not blocked and is high enough to produce the required draught. Check that there is an adequate air supply near the burner and that a kitchen fan is not drawing products out of the burner.
11 Oil odours.	Check all fuel line connections, remake as necessary.
12 Combustion fumes smell.	Check boiler cleaning cover and seal are correctly fitted. Check burner is correctly fitted onto flange. Check flue is correctly sealed into flue outlet of boiler. Check the condensate pipe and trap are operating correctly.

# 12 Spare Parts

This section gives an exploded view of the Ecoflam MAX1 burner in the Grant CONDENSING Wall Hung boiler, and a parts list associated with it.

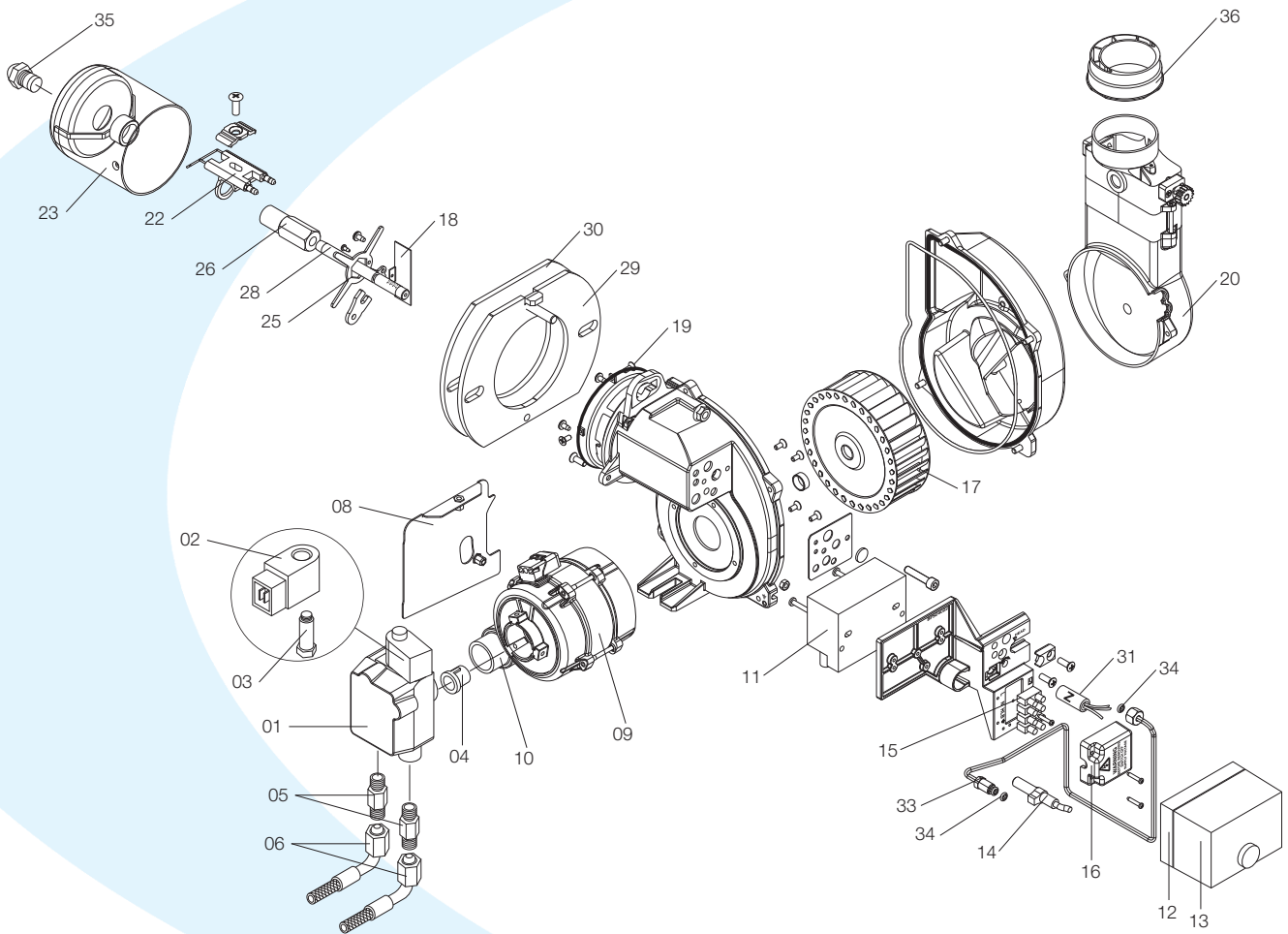

Figure 12-1: Burner components diagram



Key No.	Description		Ecoflam Part No.	Grant Part No.
01	Oil Pump	Danfoss BFP11 R3	P121/3	EBS01
02	Coil	Danfoss	V510/2	EBS02
03	Oil valve	Danfoss	V412/1	EBS03
04	Coupling	AEG	MP504	EBS04
05	Nipple	TN 6X 700	BFRO1103/001	EBS05
06	Hoses	NW 6X 700	S931/055	EBS06
09	Motor	75W AEG	M181/12	EBS09
10	Capacitor	3 $\mu$ F x 75W AEG	C107/9	EBS10
11	Ignition transformer	Danfoss CM	T130	EBS11
12	Control box base	Landis	A402	EBS12
13	Control box	Landis LOA24	A117/1	EBS13
14	Photoresistor	Landis	A208/3	EBS14
15	Wiring terminal box		E228	EBS15
16	Protection box		BFC02046/056	EBS16
17	Fan	120 x 34	W123/2	EBS17
18	Fan scoop		BFC02049/001	EBS18
19	O-ring		BFG01043	EBS19
20	Cover air inlet - Wall-hung 40/55		BAA10019	EBS20
21	Cables		BFE01401/3	EBS21
22	Electrodes		BFE01109	EBS22
23	Burner head		BFB01326/007	EBS23
25	Nozzle holder support		BFC10031/001	EBS25
26	Nozzle holder		BFC11017	EBS26
28	Rod		BFA06429/001	EBS28
29	Flange		BFF01022/001	EBS29
30	Gasket		BFG02016	EBS30
31	Anti-jamming filter	D.E.M	S132/3	EBS31
33	Oil pipe		BFT05258	EBS33
34	Pipe gasket		BFG01042	EBS34
35	Nozzle - Wall-hung 12.7kW	0.35 80°EH	-	M1BS27/75
	Nozzle - Wall-hung 14.0kW	0.40 80°EH	-	M1BS27/50
	Nozzle - Wall-hung 16.5 & 18.7kW	0.50 80°EH	-	M1BS27/46
	Nozzle - Wall-hung 20.3kW	0.60 80°EH	-	M1BS27/31
36	Ring		BFC03039/4	EBS36

# 13 Health and Safety Information

Under the Consumer Protection Act 1987 and Section 6 of the Health & Safety at Work Act 2005, we are required to provide information on substances hazardous to health (COSHH Regulations 1988).

Adhesives, sealants and paints used in the manufacture of the product are cured and present no known hazards when used in the manner for which they are intended.

The following other materials are present in the product:

## 13.1 Insulation Materials

**Material Types:** Ceramic fibre board, mineral wool.

**Description:** Rigid board, slabs, sleeves, gaskets, ropes.

**Known Hazards:** May cause temporary irritation or rash to skin. High dust levels may irritate eyes and upper respiratory system.

**Precautions:** Avoid unnecessary or rough handling, or harsh abrasion of boards. Normal handling and use of material should not produce high dust levels.

Avoid inhalation, and contact with skin and eyes.

After handling always follow normal good hygiene practices.

**Protection:** Use disposable gloves, face mask and eye protection.

**First Aid:** Eyes - If irritation occurs, wash eyes with copious amounts of water. If symptoms persist, seek immediate medical advice.

Skin - If irritation occurs, wash under running water before washing with soap and water.

Inhalation - Remove to fresh air, drink water to clear throat and blow nose to remove dust/fibres.

Ingestion - Drink plenty of water.

**Material Types:** Silicone elastomer.

**Description:** Sealant and adhesive.

**Known Hazards:** Irritation to eyes.

**Precautions:** Avoid inhalation of vapour, contact with eyes and prolonged or repeated contact with skin.

After handling always follow normal good hygiene practices.

**Protection:** Use eye protection. Rubber or plastic gloves should be worn where repeated contact occurs and a face mask worn when working in confined spaces.

**First Aid:** Eyes - Flush eyes with water for 15 minutes. Seek immediate medical attention.

Skin - Wipe off and wash with soap and water.

Inhalation - Remove to fresh air.

## 13.3 Kerosene and Gas Oil Fuels (mineral oils)

**Known Hazards:** The effect of mineral oils on the skin vary according to the duration of exposure and the type of oil.

The lighter fractions remove the protective grease naturally present on the skin, leaving it dry, liable

to crack and more prone to damage by cuts, abrasions and irritant chemicals.

Skin rashes (Oil acne) most often on arms, but also on any part of the body in contact with oil or oily clothing.

Contact with fuel oils can cause dermatitis.

**Precautions:** Avoid as far as possible any skin contact with mineral oil or with clothing contaminated with mineral oil.

The use of a lanolin-based barrier cream is recommended, in conjunction with regular washing with

soap and rinsing with water to ensure all oil is removed from the skin.

Take care to prevent clothing, especially underwear, from becoming contaminated with oil.

Do not put oily rags or tools in pockets, especially trouser pockets.

Have first-aid treatment at once for an injury, however slight.

Do not inhale any vapours from mineral oils.

# 14 EC Declaration of Conformity

We declare that the Grant Condensing range of Oil Boilers equipped with Ecoflam MAX1 burners approved to EN 267: 1999 satisfy the requirements of the following European Directives:-

1. 89/336/EEC - Electromagnetic Compatibility Directive  
Referred to the generic standards EN 55014: 1993, EN 50082: 1: 1992
2. 73/23/EEC - Electrical Equipment Safety Regulations Directive  
Referred to the generic standard NO: 3260: The Electrical Equipment (Safety) Regulations: 1994
3. 92/42/EEC - Hot Water Boiler Efficiency Directive  
Referred to the generic standard The Boiler (Efficiency) (Amendment) Regulations 1994 (SI 1994/3083).

## In EU Countries

The following information is provided to enable regulatory compliance with the European Union (EU) directives identified and any amendments made to these directives when using electrical or electronic equipment in EU countries.

### Disposal of Electrical and Electronic Equipment

European Union (EU) Directive 2002/96/EC Waste Electrical and Electronic Equipment (WEEE)

Do not dispose of electrical or electronic equipment in landfill sites. In the EU, it is the individual recipient's responsibility to ensure that discarded electrical or electronic materials are collected and recycled according to the requirements of EU environmental law.

### Disposal of Surplus Packaging

European Parliament and Council Directive 94/62/EC Packaging and Packaging Waste

Do not dispose of surplus packaging in landfill sites. In the EU, it is the individual recipient's responsibility to ensure that packaging materials are collected and recycled according to the requirements of EU environmental law.

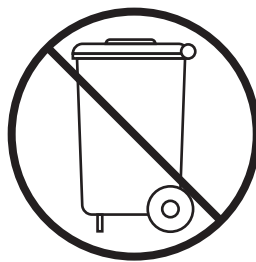

## In non-EU Countries

In non-EU countries, dispose of electrical and electronic equipment and all surplus packaging in accordance with national and regional regulations.

Complies with EC Low voltage Electromagnetic compatibility and Boiler efficiency Directives.

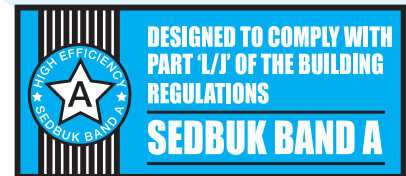



## Overheat Thermostat

Your boiler is fitted with a safety overheat thermostat which will

automatically switch off the boiler in the

case of a control malfunction causing

overheating. If your boiler goes off and

you try to light it but nothing happens,

and the 'Lock-out' neon on the control

panel is not lit, the overheat thermostat

has probably operated. The boiler will

not light until the thermostat is reset. To

reset, unscrew the small plastic cap

marked reset (see Figure 1), press the

button then replace the cap.

If this condition continually repeats,

contact your Service engineer.

Refer to the instructions supplied with

your particular system programmer.

## Ventilation

Always ensure that the boiler has

adequate ventilation. Any ventilation

openings provided by the installer must

not be obstructed.

Periodically check that they are clear.

Do not attempt to 'box in' the boiler or

build a compartment around it before

consulting your installer.

Do not place any combustible material

around or on the boiler or flue pipe

The flue terminal, which may be on the

outside wall must not be obstructed or

damaged.

In severe conditions check that the

terminal does not become blocked by

snow.

## Frost Protection

Your installer may have fitted a frost

thermostat. If not, and you are likely to

be away for a short time, leave the

boiler on with the boiler thermostat set

at a low setting. For longer periods the

boiler and system should be drained.

Contact your Service engineer for

draining and filling the system.

## Cleaning and Servicing

Lightly wipe over the case with a damp

cloth and a little detergent. Do not use

abrasive pads or cleaners.

You must have your boiler serviced at

least once a year to ensure safe and

efficient operation. Contact your Service

engineer for further details.

If the electricity supply fails, the boiler

will not operate. It should relight

automatically when the supply is

restored.

If a remote programmer is connected, it

may retain the time settings for some

time and may not have to be reset to the

correct time of day when the supply is

restored. Refer to the instructions

supplied with your programmer for

further details. It is recommended that

you check the time settings after a

power failure has occurred.

## Electricity Supply

The boiler requires a 230/240 V ~ 50 Hz

supply. It must be protected by a

5 Amp fuse.

# WARNING



The electricity connections to the

boiler must be earthed.

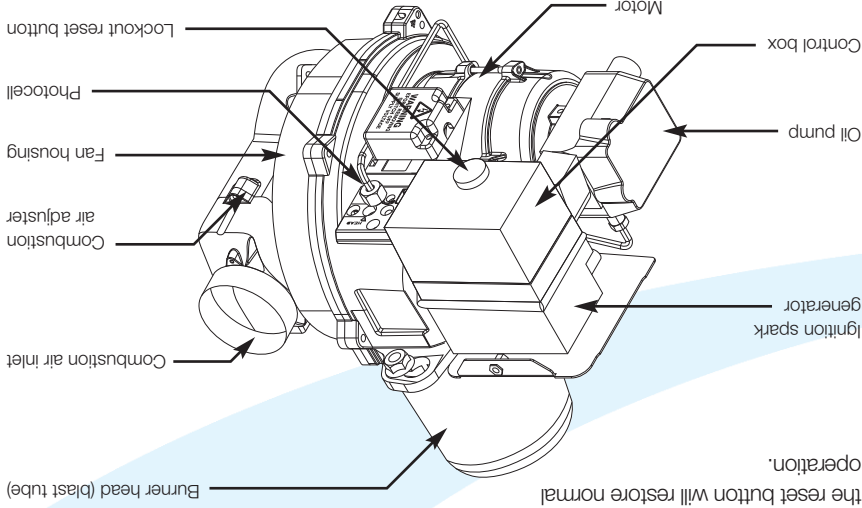

Figure 3: Burner fuel pump

Figure 3 shows the Lockout Reset button along with other main burner components.

Make the following checks:

1. Check that the boiler On/Off switch is ON.
2. Check that the programmer is working and is in an 'on' period.
3. Check that all thermostats are set to the desired setting and are calling for heat.
4. Check if the burner 'Lock-out' indicator neon on the control panel is lit. If it is, locate the lockout reset button on the burner behind the control panel. See Figure 3.
5. Press the Reset button on the burner. If the burner fails to light and goes to 'Lock-out' again, check that you have sufficient fuel in the storage tank and that the fuel supply valve is open.
6. Check that the fire valve in the oil supply line has not tripped.
7. Ensure that a fuse has not blown or that the electricity supply has not failed.
8. Check to see if the overheat thermostat has operated. See the section Overheat thermostat.

If the burner still fails to light after carrying out these checks then a fault exists or the fuel supply is low. If you have sufficient fuel, switch off the electricity supply to the boiler and contact your Service engineer.

If the burner still fails to light after carrying out these checks then a fault exists or the fuel supply is low. If you have sufficient fuel, switch off the electricity supply to the boiler and contact your Service engineer.

Grant Condensing Wall Hung boilers operate only on Class C2 Kerosene to BS 2869:1998.

**About your Fuel**

You should always quote this type of fuel when ordering from your supplier. Do not wait until the fuel runs out before you order some more. Sludge in the bottom of the tank may be drawn into the fuel lines. If it is possible, switch off the boiler when the new supply is delivered and leave the fuel to settle for an hour before restarting the boiler.

**General Notes and Care of your System**

**Boiler Thermostat**  
This control allows adjustment of the temperature of the water leaving the boiler to heat the radiators and domestic hot water.

**NOTE**

**If you have a cylinder thermostat on your hot water cylinder, this will control the temperature of your domestic hot water. The boiler thermostat setting must be equal to or above the cylinder thermostat setting to enable the cylinder thermostat to control the domestic hot water system.**

**Burner Lock-out Indicator and Reset Button**

If there is a burner malfunction, a built-in safety circuit switches the burner off and the 'Lock-out' indicator neon (on the control panel) will light. Usually such malfunctions are short lived and pressing the reset button will restore normal operation.

Make the following checks:

1. Check that the boiler On/Off switch is ON.
2. Check that the programmer is working and is in an 'on' period.
3. Check that all thermostats are set to the desired setting and are calling for heat.
4. Check if the burner 'Lock-out' indicator neon on the control panel is lit. If it is, remove the upper front casing panel and locate the lockout reset button on the burner behind the control panel. See Figure 3.
5. Press the Reset button on the burner. If the burner fails to light and goes to 'Lock-out' again, check that you have sufficient fuel in the storage tank and that the fuel supply valve is open.
6. Check that the fire valve in the oil supply line has not tripped.
7. Ensure that a fuse has not blown or that the electricity supply has not failed.
8. Check to see if the overheat thermostat has operated (see the section Overheat thermostat).

If the burner still fails to light after carrying out these checks then a fault exists. Switch off the electricity supply to the boiler and contact your Service engineer.

**Turning off your Boiler**

**For short periods:** Set the On/Off switch to OFF.

To restart, simply set the switch to ON.

**For long periods:** Set the On/Off switch to OFF and switch off the electricity supply to the boiler. If required, the fuel supply valve may be closed and the water and electricity supplies turned off at the mains.

To restart, refer to the full lighting instructions given in the Section Lighting your boiler.

# User Instructions

## Introduction

This User Guide is intended to assist the user in the operation of the Grant CONDENSING Wall Hung boilers. The engineers manual for the boiler is attached to the reverse of these instructions.

The following special text formats are used in this manual for the purposes listed below:



## WARNING

Warning of possible human injury as a consequence of not following the instructions in the warning.



## NOTE

Note text. Used for emphasis or information not directly concerned with the surrounding text but of importance to the reader.



Figure 1: Boiler lower front panel in down position

## About your Boiler

The boiler is fully automatic once switched on, providing central heating (and also heating your domestic hot water if you have a hot water cylinder fitted). The boiler has a 'mains on' neon, which lights when the boiler is switched on, but does not necessarily indicate the burner is firing. If your model is controlled by a remote programmer and a room thermostat, it will provide hot water and central heating during the periods as set on the programmer, when either the room thermostat and/or the hot water thermostat are calling.

### Boiler Controls

1. To access the controls, open the lower front panel by pulling it down as shown in Figure 1

The controls are shown in Figure 2.

## Lighting your Boiler

The lighting procedure is:

1. Ensure that there is sufficient fuel, of the correct type, in the supply tank and all fuel supply valves are open. The water supply is on. The electricity supply to the boiler is off. The boiler On/Off switch is set to OFF. The room thermostat (if fitted) is at the desired setting. The boiler thermostat is set to the required setting.
2. Switch on the electricity supply to the boiler.
3. Set the On/Off switch to ON, with the remote programmer (CH or HW) also ON.
4. The boiler will now light automatically.
5. Set the HW and CH functions to TIMED. The boiler will now operate during the 'on' periods set on the programmer.



Figure 2: Boiler controls

# Contents

Introduction	4	Overheat Thermostat	6
About your Boiler	4	Remote Programmer	6
Boiler Controls	4	Ventilation	6
Lighting your Boiler	4	Flue Terminal	6
If your Boiler Fails to Light	5	Frost Protection	6
Turning off your Boiler	5	Cleaning and Servicing	6
About your Fuel	5	Failure of Electricity Supply	6
General Notes and Care of your System	5	Electricity Supply	6
Boiler Thermostat	5		
Burner Lock-out Indicator and Reset Button	5		



**For use with Kerosene only.**

After installing the boiler leave these instructions with the User.

**Service Log**

It is recommended that the boiler should be regularly serviced, at least once a year, and the details entered in the Boiler Handbook by the service engineer.



**EFFICIENT HEATING SOLUTIONS**

**GRANT ENGINEERING (IRELAND) LIMITED**

Crinkle, Birr, Co. Offaly, Ireland

Tel: (057) 91 20089 Fax: (057) 91 21060

Email: [info@grantengineering.ie](mailto:info@grantengineering.ie) [www.grantengineering.ie](http://www.grantengineering.ie)

This manual is accurate at the date of printing but will be superseded and should be disregarded if specifications and/or appearances are changed in the interests of continued product improvement.  
 © Grant Engineering (Ireland) Limited 2008. No part of this manual may be reproduced by any means without prior written consent.



# Grant Condensing Wall Hung Condensing Oil Boiler Range User Instructions