

# Mini Induction Heater Circuit

## (ZVS Power Resonator)

### CRO-SM2

*Ultra Compact Self Resonating Power Oscillator for Induction Heating and Wireless Power*

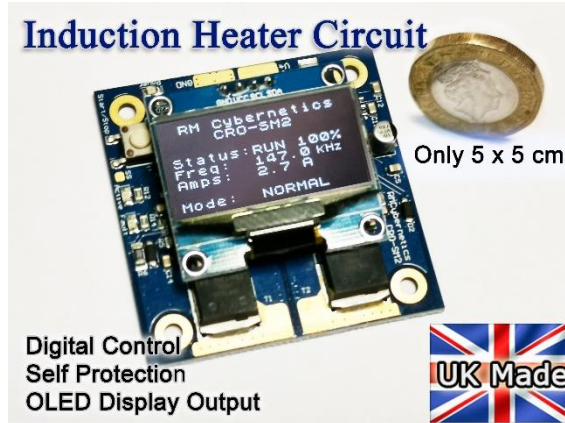

## Features and Specifications

- Automatic Resonance, no tuning needed
- Ultra-compact size: L50 x W50 x H8\*\*\* mm
- Wide supply voltage range (12V – 26V)
- ZVS (Zero Voltage Switching)
- Current up to 20A continuous\*, 70A peak
- I<sup>2</sup>C output for OLED displays
- Digital protection from overload
- Built in output power control
- Flat base for mounting directly to metal enclosures\*\*
- High quality double layer PTH, 2oz Copper PCB

\* Max current varies with operating conditions.

\*\* Electrical isolation required using thermal interface material

\*\*\* Excluding Heatsink.

## Example Applications

- Induction Heating
- Wireless Power Transmission
- Solid State Tesla Coils
- DC-AC and DC-DC Power Inverters
- 3D Printers
- Annealing
- Metal Casting
- Heat Treatment & Hardening
- Resonant Energy Experiments
- And more...

## Typical Usage

The most common use for the CRO-SM2 is as an induction heating circuit. When connected to an appropriate coil like our CT-400 coils, it can be used for induction heating with peak power levels up to 500W. This power level is adequate for heating small parts to red hot temperatures.

The small size and versatility of the CRO-SM2 makes it ideal for embedded applications where it is integrated into a system to provide the induction heating element.

The CRO-SM2 is an updated replacement for our popular product the CRO-SM1. We also offer customisation services where we can write custom firmware, or build custom electronic devices for you.

## Optional Display

The PCB has an I<sup>2</sup>C output for connection to common OLED display modules. When connected, the display will show the output status, resonant frequency and input current. Other information (input voltage, input power, coil voltage, and PCB temperature) can also be displayed in diagnostic mode. All these values are constantly monitored by the circuit for protection, if any parameter goes outside limits, or resonance fails, then the output driver is shut down, and an error code will be displayed. These errors are also displayed by a flashing LED so the display is not essential for operation. See the special modes section for more details on using a display.

## Mode of operation

The CRO-SM2 is a type of collector resonance oscillator circuit which will automatically drive low impedance LC tank circuits at their resonant frequency. This is ideal for making a **DIY Induction Heater** or Wireless Power circuits. It is designed to drive a parallel LC circuit (a coil and capacitor connected in parallel) like our CT-400 coils. It can be connected in numerous configurations, but generally is used to drive a coil with power fed to it by an appropriately sized choke.

The system is activated by a push button built onto the PCB, or can be connected to an external switch or microcontroller. One press will activate/deactivate the resonant power output while a long press can

be used to cycle through the power modulation modes. Onboard LEDs or the optional display will indicate the output mode and status.

The circuit will **automatically drive at resonance** even if the resonant frequency changes such as when a metal object is placed inside an induction heater.

**It is important to read ALL these instructions carefully to ensure that the circuit will operate properly. If there is anything you are not sure about, please contact us for support.**

## ELECTRICAL CHARACTERISTICS

NB: Figures may vary under different loading conditions and environments.

Symbol	Parameter	Min	Typical	Max
$V_{in}$	Input Supply Voltage	12V <sup>1</sup>	15 V	26 V
$V_{power}$	Load Supply Voltage	0 V	15 V	30 V
$I_{sup}$	Supply Current (no load)	20 mA	30mA	50 mA
$I_{out}$	Continuous Output Current	0 A	-	20 A <sup>3</sup>
$I_{pulse}$	Pulse Current <sup>2</sup>	-	-	70 A
$V_{logic}$	Logic (High) Voltage	3.3 V	5 V	5 V
$T_{limit}$	Thermal Protection Threshold	-	90 C	100 C
$V_{CoilLimit}$	Coil Voltage Protection Threshold	-	85 V	-
$V_{InLimit}$	Input Voltage Protection Threshold	10 V	-	28 V
$I_{limit}$	Current Protection Threshold	8 A	-	20 A

Table 1: Electrical Characteristics

<sup>1</sup> 12V is absolute minimum. 14 to 24V recommended. <sup>2</sup> Pulse current is transistors max rated DC current at 25°C.

<sup>3</sup> Max current depends on cooling and operating frequency. At >100kHz we suggest no higher than 10A

## Cooling Options

To switch more power, the circuit must be kept cool. Below you can see three typical passive configurations. The heatsink required will vary depending on various factors such as ambient air temperature and the operating frequency. You can also used forced air cooling (a fan) mounted to cool the component side to improve the power handling capability. If purchased with a heatsink option, it will be supplied with a piece of double sided adhesive thermal pad. Use this to fix the PCB to the heatsink. No screws are needed.

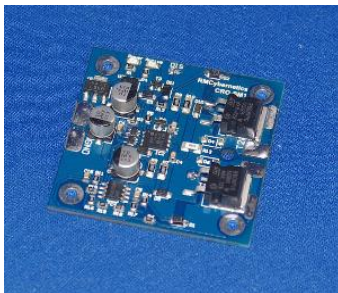

PCB Only

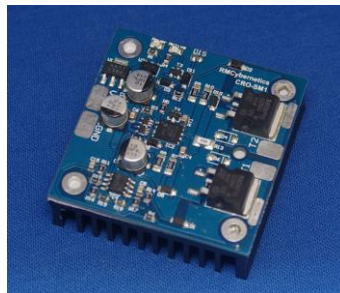

Small Heatsink

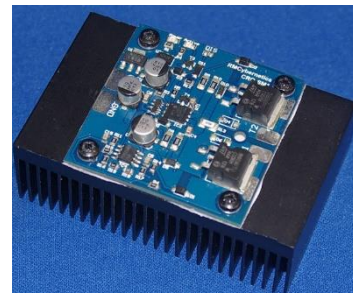

Large Heatsink

Figure 0: Various Heatsinks

## Connections

The CRO-SM2 circuit can be powered from a 12V to 26V supply, while the load device itself can be powered from a separate lower voltage supply if desired. Typically, the circuit and load will both be connected to the same supply for simplicity.

Connections are made by soldering directly to the solder pads provided on the PCB. Note that this will require a good soldering iron or to pre-heat the PCB as the thick copper surfaces will quickly dissipate applied heat.

**PLEASE READ THE IMPORTANT USAGE NOTES ON PAGE 9 BEFORE USE**

Power to the load must be delivered via a suitable power inductor or choke. A typical choke could be 85uH and rated for enough current to suit your application. For induction heating at typical power levels we suggest using the 100uH 15A choke available on our website.

The load supply ( $V_{power}$ ) should be connected to a suitable DC power supply which is rated for typically 10A or more (this can be the same connection as V+).

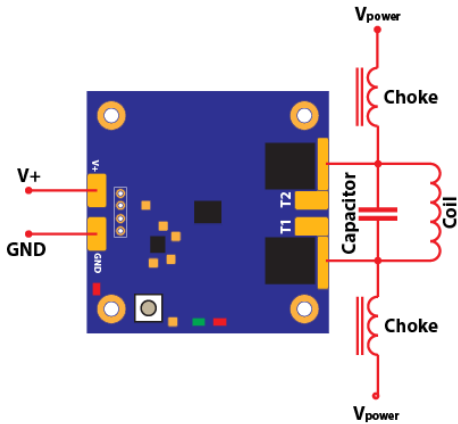

Figure 1: Connection diagram for standard coils

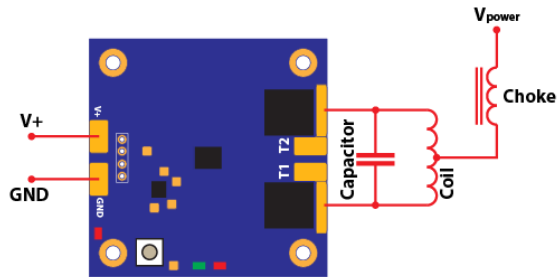

Figure 1b: Connection diagram for centre tapped coils

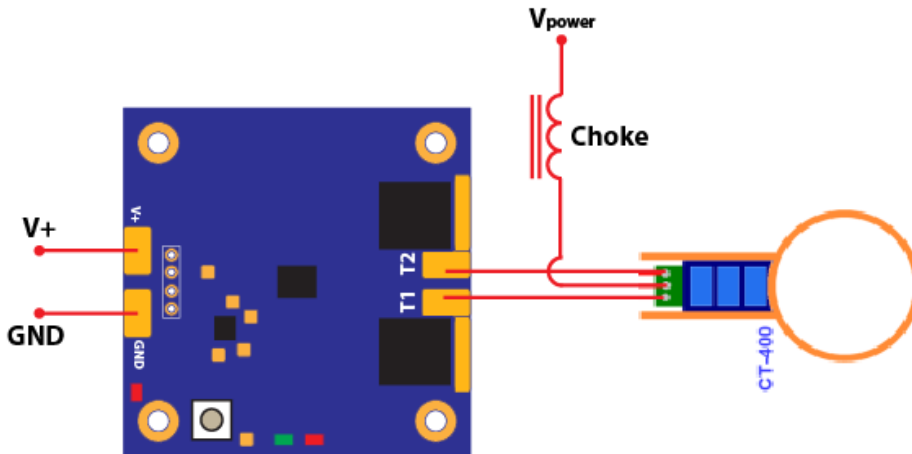

Figure 1c: Connection diagram for our CT-400 coils

Connection	Description
V+	Circuit positive supply input 12V to 26V DC
GND	Circuit ground or negative supply input
$V_{power}$	Load positive supply input to choke (can be connected to V+ for single supply use)
T1, T2	Connection for load
Choke	Use suitable inductor with current rated for your application recommended >50uH
Capacitor	Tank capacitor(s) to form part of the resonant circuit. Must be polypropylene or equivalent
Coil	Load coil such as transformer primary or induction coil

Table 2: Connections

The output connections are labelled T1 and T2. These are connections for the ends of a load coil and capacitor. Note that the output terminals do not themselves supply any voltage. The voltage for the load must be provided via a choke (inductor) to T1/T2 or the centre connection of a centre tapped coil.

The coil to be resonated should also have suitable capacitors in parallel with it. It is the inductance of your coil and the total capacitance that will determine the operating frequency. When connecting to a resonant load such as an induction heater or DRSSTC, the coil and capacitors should be connected to each other as close as is practically possible and should also connect very close to the circuit. Long wires can cause problems with oscillations starting up or poorly shaped waveforms.

The image below shows a typical setup where the CRO-SM2 is used to make an induction heater. The parts used can be found in the related products section below.

### Cooling Fan & Radiator



Figure 2: Example Water Cooled Induction Heater Setup

In the example above, the induction coil is water cooled. This is essential due to the very high currents oscillating between the coil and capacitors.

When there is no workpiece (metal) placed inside an active coil, the coil current will be higher and cause more waste heating. The CRO-SM2 has an optional mode where it can limit power until a workpiece is added. See *Special Modes* below for more details.

## Output Load Considerations

The current oscillating between the coil and capacitor bank will be much higher than the input current to the circuit ( $V_+$  or  $V_{power}$ ) and therefore the coil must be made of very thick wire, litz wire, or copper pipe and may need to be water cooled.

It is important to use good quality polypropylene (or equivalent) capacitors that are capable of withstanding large currents and show good temperature stability. Using low quality capacitors will result in no resonance, poor efficiency, or possible circuit damage.

**Induction Coil Shapes and Sizes**

The size of the coil used will determine its inductance. Larger coils have more inductance for the same number of turns. The example in the photo above is about 4cm in diameter and is about the smallest size that will work with only 4 turns. This had an inductance value of around 700nH. If a smaller diameter is required, then a larger number of turns will be needed to keep the inductance high enough. If the inductance is too low, then the circuit will fail to oscillate and the output will be disabled.

**Protection Circuits & LED indicators**

Three LEDs are used to indicate the operational status of the CRO-SM2. A red Power LED indicates the board has power applied to the inputs, a green LED comes on when the output transistors are active, and another red LED is used to indicate errors and modes of operation.

The CRO-SM2 has a range of built in protection systems to prevent accidental damage and to provide reliable operation. Fault conditions are indicated by the number flashes of the red Fault LED followed by a pause. In any fault condition, the output is disabled. To restart the circuit, press the Start/Stop button to clear the fault, the press again to enable the output.

Flashes	Fault	Cause
1	Input Voltage too High	A voltage of around 28V or more has been applied to the input. This can be caused by input power spikes. Sustained over voltage will cause the circuit to shut down. Note that continuous voltages over 26V may cause permanent damage to the circuit.
2	Input Voltage Too Low	The input voltage has dropped below the minimum required for normal operation. This can happen if your PSU is unable to deliver enough current when switching on or adding a metal workpiece to an active coil.
3	Coil Voltage Too High	Coil voltage can rise in resonant conditions or from power spikes. If it rises above the safe threshold, this fault code will activate. This is more likely to occur with high inductance, low capacitance loads, or when no workpiece is inside an induction coil.
4	PCB High Temperature	Onboard thermistor is detecting a high temperature. Improved cooling is needed to operate if this is occurring.
5	Overload (High Current)	Too much output current. This can be due to a short circuit, or the metal workpiece in a coil being too large. The max current that triggers this fault will change with the detected PCB temperature. Higher temperatures will lower the max current rating. The optional OLED display will indicate the max allowed during operation.
6	Resonance Failure	Coil failed to resonate. This can be due to a faulty / incompatible coil, too large of a work piece, or other issue. This can occasionally occur anyway, but if it happens often, then check for problems with the setup.

Table 3: LED flashes and fault codes

Proper system design is essential for long term reliable operation. It is not recommended to operate the circuit continuously when protection modes are activating as more heating in the circuit may occur. The protection circuits should only be considered as backup as failure to operate the circuit within specifications could cause the transistors to fail.

## Notes on Protection

The PCB must be mounted on a heatsink for the temperature sensor to work correctly. It is also important to consider that some components (such as the output transistors) may heat up very quickly in high load conditions and could therefore fail before the temperature sensor has warmed up and detected any problem.

The protection circuits have limited response time and may not be able to protect from very large fast transients or changes. When using an OLED display, there is an added latency between detecting error states and shutting down.

## Power Modulation

You can adjust the heating power of a resonating coil by simply adjusting the supply voltage. Alternately, you can use the CRO-SM2's built in modulation function to select a power level of either 25%, 50%, 75%, or 100%. To select a power level, hold the on/off button until you see the green LED flash. The number of flashes indicates the power level selected. Keep holding the button down to cycle through the available power levels. Power levels can be adjusted when the output is either on or off.

Flashes	Power Level
1	25%
2	50%
3	75%
4	100%

Table 4: LED flashes and power levels

The power modulation works by simply powering the coil on and off roughly every second or so. For example, at 25%, the coil will be powered for 250ms, and then off for 750ms. This cycle is repeated to give an average heating power of 25%.

Power modulation can cause current spikes and higher chances of resonance failure. It is not recommended to use this feature under high load conditions or when operating near the circuit's max ratings.

The power level selected is stored in memory and will be retained even after the circuit powers off.

## Special Modes & External Interfacing

There are several small solder pads on the PCB which can be used to alter the way the CRO-SM2 operates. The pads are un-marked and quite small so will require identifying using the image below, and connections made carefully.

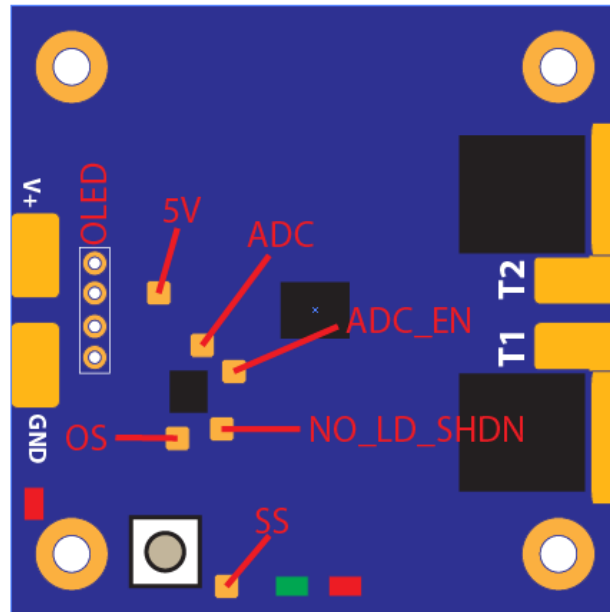

Figure 3: Special Connections

Pad ID	Function	I/O	Description
SS	Start / Stop	IN/OUT	<p>Connected to the push button. Pull low then high to toggle power output state. Hold low then release to adjust modulation setting.</p> <p><b>AUTO MODE</b>                      If held low during power up, the output will automatically enable after approximately 2 seconds and stay on until powered down or an error condition occurs. An error in this mode will only briefly disable the power output. After about one second, the output will restart. If the fault is not rectified and the device continues to retry, damage to the circuit may eventually occur.</p>
OS	Output State	OUT	<p>Pad is set high when the circuit power output is active. Useful for when interfacing with a microcontroller for automation.</p> <p>Note that when power is being modulated, OS will remain high even during the low part of the modulation cycle.</p>
ADC	Analogue input for sensor	IN	<p><b>ADC WAIT MODE</b>                      When a voltage applied here exceeds approximately 1V, the power output is disabled until this voltage falls back below 1V. Useful for automatic temperature regulation using an external probe.</p>
ADC_EN	Analogue input enable	IN	<p>Pull low to enable the ADC pin, otherwise it is ignored.</p>

NO_LD_SHDN	No Load Shutdown	IN	<p><b>SET CURRENT MODE</b></p> <p>With the power output running, briefly pulling this pin low will save the current power state as the minimum acceptable load*.</p> <p>If the measured current falls approximately 0.5A below this value, the power output will be disabled until the current is high enough again. Roughly every second, the coil will be pulsed to measure the current.</p> <p>To reset this value to zero, this input should be pulled low when the output state has been manually disabled. Alternately, powering off the circuit, or changing selected power level will reset this.</p> <p>NB: This mode will not work while the device is in other special modes such as power modulating or using the ADC</p>
5V	5V Output	-	Connection to the onboard 5V, 100mA regulator. Useful for powering an external microcontroller or sensors.

Table: 5 – Optional I/O interfaces

\* Boards sold before December 2020 will save this in non-volatile memory and will retain the setting even after the circuit has been powered off and on again. This feature has since been removed so that it is simpler to reset to normal operation.

### Using an OLED Display

Most common I<sup>2</sup>C OLED modules with a 128x64 pixel resolution can be used with the CRO-SM2. The pinout (bottom to top in figure 3) is GND, VCC, SCL, SDA. Compatible displays with a matching pinout are available on our website.

Note that all four pins for the display connect to the onboard microcontroller I/O and are limited to 20mA max,

The CRO-SM2 will automatically detect when a display is detected and change its operation accordingly. When a screen is used, there will be some additional latency in operating the controls and general responsiveness. Start-up time will increase from 2 seconds to about 4 seconds with a display attached.

By default, the display will show the output state, selected power level, resonant frequency, any special modes and error codes. Additional information can be displayed by starting the device in **debugging mode**. To enter debugging mode, the GND connection of the screen must have an additional connection made between the circuit GND and the OLED GND before powering on the device. Debugging mode adds further latency to the operation of the device.

All variables shown are approximate and uncalibrated. Two different circuits may show slightly different values for the same parameters.

A display can be soldered directly to the PCB or a socket can be fitted to allow easy removal. If the CRO-SM2 is to be mounted to a heatsink, it is important to make sure that when fitting a screen, no pins or solder bumps are protruding through to the underside of the PCB. The underside of the PCB must be totally flat for proper heatsink mounting.



## Important Usage Notes

When using this circuit for the first time we suggest following some basic guidance to ensure you will become familiar with its operation and to get the most use out of it.

### Essential Considerations

#### Power Supply

At start-up there can be a brief high peak current before resonance starts. It is important that your PSU can deliver this current without dropping voltage otherwise it could fail to operate correctly or even damage the power MOSFETS. Your PSU must be rated for at least 10A for most induction heating applications. It can also help to add a large capacitor at your PSU output.

#### Output Connections

All wiring after the connection points of T1 and T2 forms part of the resonant circuit. Long trailing wires to your coil will have a significant effect on operation and should be avoided. Long wires may cause start-up failure or false resonance conditions which can both lead to damaged MOSFETs.

By connecting tank capacitor directly to T1/T2 terminals, this will include your connecting wires as part of the resonant tank with your work coil. This may allow proper resonance with longer wiring, but it will lead to increased losses in those wires (unless using suitable litz wire). It will also mean that if you move/bend those wires, the output power and frequency may change due to changes in the inductance.

#### Work Coil Design

The work coil and tank capacitor will affect all aspects of operation including heating power, current draw and resonant frequency. A larger coil (more turns, or wider diameter) will lead to a lower resonant frequency and usually lower power levels. You should design your work coil to suit the PSU, workpiece and tank capacitor.

A smaller tank capacitor will lead to higher resonant frequencies, but added ESR (resistance) of using fewer parallel capacitors may lead to lower useful power levels due to component heating.

#### Workpiece

The size and material of your workpiece will have a very significant effect on the power consumption. Magnetic materials like iron will have a very strong reaction and will heat well, whereas non-ferrous materials like titanium, will have only a minimal response.

When the workpiece is within the coil, it can cause a large increase in current from the PSU. Your PSU must be rated to handle this. If the workpiece is within the coil before the CRO-SM2 is started, the large peak current could damage a MOSFET if power levels are high. We suggest always starting resonance without the workpiece in the coil.

#### Choke Selection

It is important that the choke is of sufficient size for your application and rated for at least the peak current that the system will see. If the inductor is saturated by excess current above its rating, this can lead to current surges that may damage MOSFETs

#### Other important considerations

- When experimenting with new loads, check the transistors are not overheating.
- High frequency operation causes more heating in the circuit and care should be taken not to overheat it.
- Use a current limited power supply to protect from accidental short circuit, overload or failed oscillation.
- Always use a fuse when used with PSUs rated above 10A. A 10A quick blow fuse is typical.

- At high power levels take care to only power the load for short periods and leave time for the CRO-SM2 to cool otherwise the transistors could fail. The hotter the device is running, the less power it can handle safely.
- Heat is transferred to the heatsink through thermal vias on the PCB which have high thermal resistance vs directly mounted transistors. Therefore, large increases in power level may cause the transistor temperature to rise faster than heat can be removed or detected by the onboard sensor.
- The PSU must be able to deliver enough current to suit your LC load. If it is not sufficient, this could prevent proper operation and damage the circuit. Adding a large electrolytic capacitor between V+ and GND can help to stabilise the supply from any voltage dips caused by start-up currents.
- Keep the wires between the circuit and load as short as possible (<10cm) when used in induction heater circuits such as our CT-400
- The heat generated in the switching transistors will vary with your loading conditions and the operating frequency. Higher frequencies will produce more heat.
- Adding a cooling fan over the component side of the PCB is an effective way to cool the device.
- The transistor/heatsink, copper surface, and LC load may rise to a higher voltage than the input supply when in use. Do not touch the PCB, heatsinks, or your load coil when powered.
- The output coil should typically be a small number of turns (<1000) for resonance to work.
- To drive more current into coils with more turns, you may need to use an impedance matching transformer.
- It is highly recommended to use a bench top PSU or fit the optional OLED display when using the circuit with unfamiliar loads. This will allow you to see if the voltage drops, or the current rises too high while you are familiarising yourself with the system.
- When mounting on a heatsink, thermal interface material must be used to isolate the PCB from the metal surface. Do not use only thermal pastes as the circuit could short out on the metal heatsink.

**Troubleshooting**

If you are having trouble getting your system working, check the notes above and try the following suggestions.

Symptom	Possible Causes	Solutions
PSU cuts off when the coil is connected, and before pressing the Start/Stop button	Blown T1 / T2 MOSFET	Remove the output connections to the coil, and use a multimeter to test which MOSFET is blown. To do this set the meter to test for a short between the T1 or T2 terminal and GND. Replace any MOSFET that shows a short.
PSU cuts off when the Start/Stop button is pressed.  Persistent Resonance Fail errors on start-up (6 red flashes)	PSU not suitably powerful for your setup.  Bad output coil configuration or.  Insufficient choke rating.	Use a PSU rated for more current, or one of a lower voltage so that less current will be drawn by the work coil.  Shorten any connecting wires and make sure the tank capacitor is closer to the PCB  Use a larger choke.

Low input Voltage error (2 red flashes)	PSU not suitably powerful for your setup. Or resonance is failing.	As above
Output LED flashes briefly around once per second	Device is in No Load Shutdown mode  This mode can sometimes be erroneously activated due to electrical noise.	Power off/on the circuit or alter the power level with a long press to reset this setting. *  If this mode keeps activating erroneously, check your wiring and PSU. Alternately, you can disable this mode by briefly connecting a wire between NO_LD_SHDN and GND when the output state has been manually disabled. (see figure 3)

Table: 6 – Troubleshooting

\* Boards sold before December 2020 will save this in non-volatile memory and will retain the setting even after the circuit has been powered off and on again. To reset these boards, follow the suggestion for the connection to NO\_LD\_SHDN. This feature has since been removed so that it is simpler to reset to normal operation.

## Customisation Available for this Product

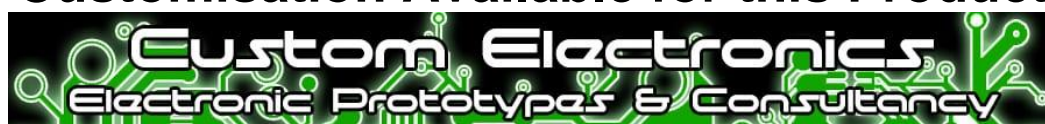

We can write custom firmware for this product, make custom coils, and help integrate it into your project. Call or email to discuss your requirements.

Tel: 01270 747008 – Email: [info@rmcybernetics.com](mailto:info@rmcybernetics.com)

## Related Products

### Product

Induction Heater Coil  
Water Cooling Kit  
12V, 30A PSU  
OLED Display  
PWM Circuit  
Polypropylene Capacitor  
Choke 15A, 100uH  
Heatsinks  
Thermal Interface Material

### MPN

[CT-400](#)  
[IHWK-4M](#)  
[12V30ASMPS](#)  
[OLED1W3](#)  
[PWM-OCX](#)  
[CAPPOLYP400V330NF](#)  
[CHK-15A](#)  
[See Website](#)  
[BOND-PLY-100](#)

The information in this document is provided as-is and is not guaranteed to be free of errors.

### RM Cybernetics LTD

31 Lawton Road  
Alsager  
Cheshire  
ST7 2AA  
United Kingdom

01270 747 008  
(+44 1270 747 008)