

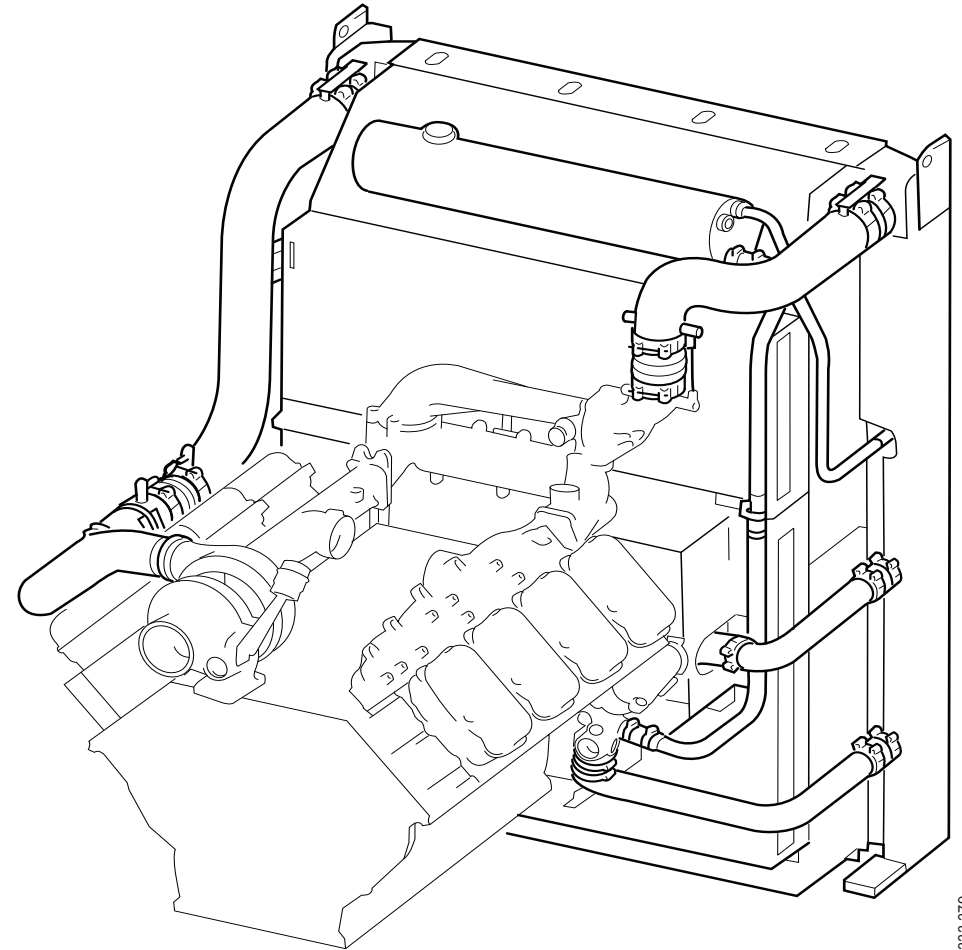

Cooling system

**Industrial engines
DC09, DC13, DC16**



333 379



Design and dimensioning	3
Expansion tank	4
Pressure drop and coolant flow.....	5
Radiators and radiator fans	7
Installation of radiator and radiator fan.....	7
Radiator fans	8
Engine-mounted radiators 1.1 m ² and 1.3 m ²	9
Cooling capacity.....	10
Thermostat	11
Connecting a cab heater.....	12
Transmission oil cooling	13
Connecting a transmission oil cooler	13
Immersion heater	15
Multi-engine installation with common cooling system	16
Filling coolant	18
Installation instructions for the cooling system	20
Protective casing for the 1.1 m ² cooling package	20
Protective casing for the 1.3 m ² cooling package	21
Pipes and hoses.....	22



Design and dimensioning

The design of the cooling system is an important part of the engine installation. It should therefore be planned carefully when ordering the engine. The cooling requirement is dependent on the engine power, engine installation layout and the surrounding environment.

If the engine is supplied from Scania without a cooling system, the radiator must have sufficient capacity for the applicable operating conditions.

Scania accepts no responsibility for the function of cooling systems which are calculated and installed other than according to Scania's instructions.

Note:

It is the responsibility of the fitter to ensure that the cooling system is dimensioned and tested so that it works in the applicable operating conditions.

The Data Handbook contains cooling system recommendations for all engines. If the engine installation and the operating conditions deviate from these recommendations, the cooling system must be designed for the relevant engine installation.

When dimensioning a cooling system, the following data must be available.

- Heat output that the cooling system must conduct away from the engine. Refer to 01:06 Technical data.
- Fan capacity. Information on the fan capacity of Scania fans is in the Data Handbook.
- Pump capacity: Coolant flow as a function of engine speed versus pressure drop. See [Pressure drop and coolant flow](#).
- The maximum ambient temperature in which the engine is to operate. Scania recommends dimensioning the cooling system with a margin of at least 5°C to compensate for any clogging of the radiator.
- Alarm limits for the coolant temperature.

The following factors must also be taken into consideration:

- With a pusher fan the cooling air is warmed up when it passes the engine. Heating is approximately 10°C with Scania standard fans. Other components which generate heat also contribute to this heating.
- Additional heat from other components connected to the cooling system.



IMPORTANT!

Dimension the cooling system for the entire engine speed range, not just for maximum engine speed.



Expansion tank

The design of the cooling system must always allow the coolant to expand in an expansion tank. The expansion tank must be positioned slightly higher than the highest part in the rest of the cooling system. The volume for expansion (proportion of air) in the expansion tank should be at least 3% and the reserve volume (proportion of coolant) should be at least 5% of the total coolant volume.

The expansion tank should be connected to the suction side of the coolant pump with a static line pipe to reduce the risk of steam build-up and cavitation in the pump. This connection should have as even a rise as possible to avoid pockets of air.

The outer diameter of the pipe or the inner diameter of the hose should be a minimum of 25 mm for DC09 and DC13 and a minimum of 32 mm for DC16.

There must always be a bleed pipe between the upper part of the radiator and the expansion tank to prevent air from entering the cooling system. The inner diameter of the bleed pipe must not be greater than 8 mm to avoid the flow becoming too great.

There must be a bleed pipe from the vent port on the cylinder heads to the expansion tank.

If an external heating system is to be connected to the cooling system, Scania recommends positioning the expansion tank higher than the external heating system.



IMPORTANT!

The expansion tank must not be positioned higher than 8.5 m above the coolant pump intake. This height corresponds to a static pressure of 0.85 bar, the highest pressure permissible on the suction side of the pump to avoid leakage.



Pressure drop and coolant flow

The coolant pipes and hose connections between engine and radiator must be dimensioned in a manner that prevents reduction of cooling capacity.

An adequate quantity of coolant and cooling air must be able to pass through the pipes and radiator. Connecting components or restriction valves in the system reduces the amount of coolant passing through the radiator and thereby reduces the cooling capacity. At the same time, this increases the pressure in thermostat housing, hoses and cooler.

The diameter of coolant lines should be 57 mm. This measurement refers to the outer diameter for pipes and the inner diameter for hoses.

The coolant lines should be made of pipe, which is bent and jointed with short straight hoses. Ribbed hoses can hinder flow.

Maximum permissible pressure drop and minimum coolant flow are depicted in the diagrams on this and the next page.

If in doubt, check that the pressure drop across the external system does not exceed permissible values.

The pressure drop is determined by measuring the difference in pressure between the thermostat housing and the intake to the coolant pump with the thermostats blocked in the open position (8 mm opening) and with no pressure cap. See the [Thermostat](#)-section.

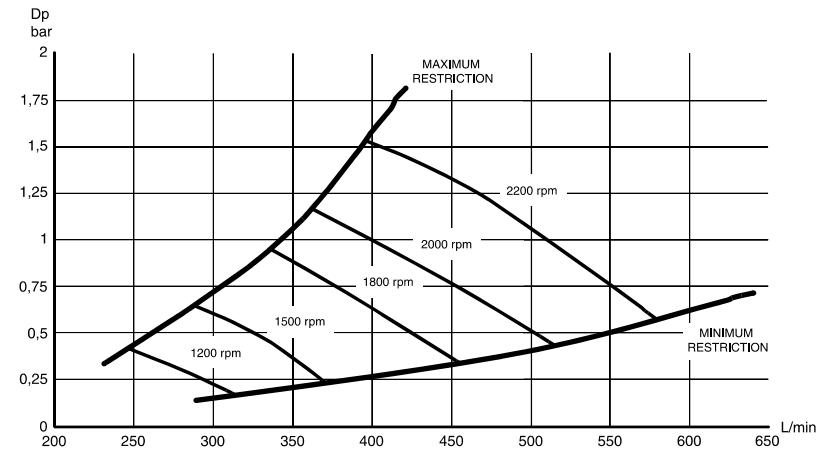

The diagram applies to DC09/DC13 with EGR system (Stage IV/Tier 4f and DC09/DC13 071A).

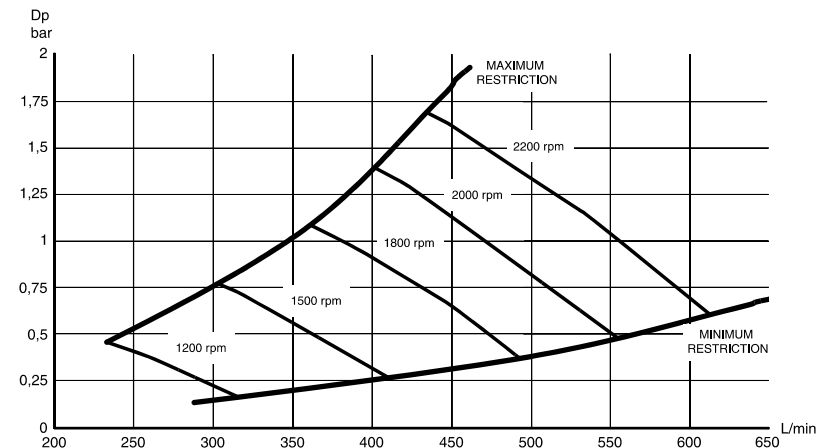

The diagram applies to DC09/DC13 without EGR system.

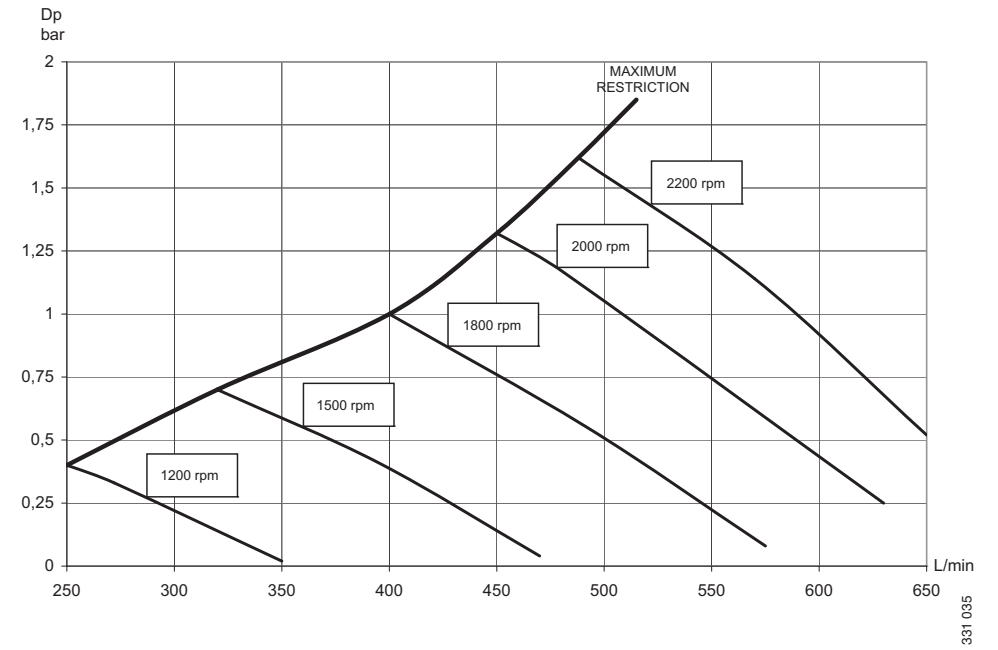

The diagram applies to DC16.



Radiators and radiator fans

Installation of radiator and radiator fan

In order to fully utilise the capacity of the radiator and radiator fan, a fan cover with fan ring should be placed between the radiator and the radiator fan. In addition there must be a sufficient distance between the radiator and radiator fan, as well as between the radiator fan and fan ring, in order for cooling to work effectively.

The optimum distance between radiator fan and radiator is $0.3 \times$ fan diameter. This is often not possible due to lack of space. 130-150 mm is acceptable as a minimum distance.

The distance between the fan blade and fan ring should preferably not exceed 6 mm as shown in the figure.

For engines with flexible engine suspension, engine movements can cause the fan to come into contact with the fan ring if it is fitted on the radiator. The alternative is to fit the fan ring on the engine and seal the ring and fan cover with an elastic spacer.

It is important for the air which has passed through the radiator and has been heated not to be recirculated so that it passes through the radiator again. It may therefore be necessary to place a shield around the radiator to prevent recirculation.

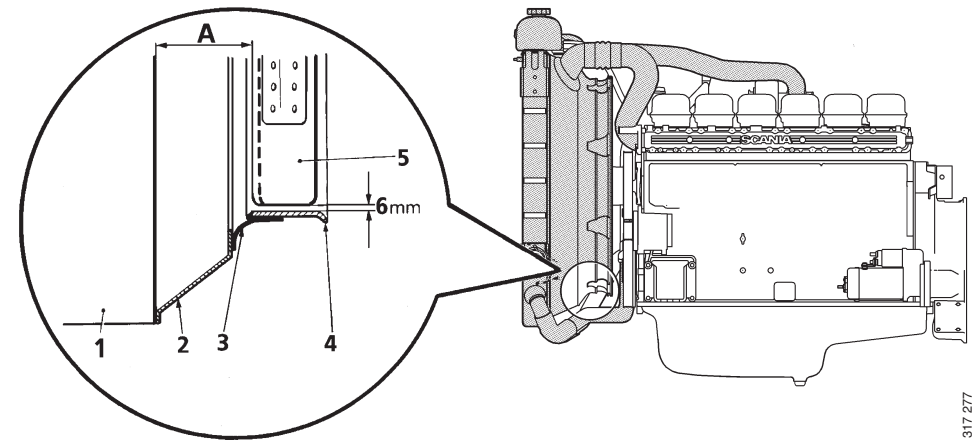

Installation of fan ring and fan cover.

A = Distance between fan and radiator. The distance should preferably be $0.3 \times$ fan diameter, but 130-150 mm is acceptable as a minimum distance.

1. Radiator.
2. Fan cover.
3. Elastic sealing ring.
4. Fan ring.
5. Fan.



Radiator fans

The engines are available with 2 types of radiator fan – a pusher fan or puller fan.

The significant difference between the two systems is that a puller fan provides a more even distribution of the air flow through the radiator. See the illustrations.

With a pusher fan, the cooling capacity is also reduced as the cooling air is warmed when it passes the engine, exhaust pipe and driven unit. A pusher fan also results in a greater pressure drop across the radiator since the distribution over the surface of the radiator is not so good.

This means that a particular size of radiator requires a larger volume of air with a pusher fan to achieve the same cooling capacity.

The fan ring must be correctly located and designed for the fan to achieve maximum air flow and to ensure that distribution across the radiator is as efficient as possible. See [Installation of radiator and radiator fan](#).

In order to optimise the cooling capacity, first check that heated air is not being re-circulated. If it is, a suitable shield must be fitted. The second measure is to increase the size of the radiator.

It is possible to optimise the fan speed or fan diameter to increase capacity. If the size of the fan or the fan speed is changed the power requirement and noise level of the fan increase. Information about permissible combinations can be found in the Data Handbook.

A pusher fan can help to combat heating of the engine compartment by dissipating heat radiated by the engine, exhaust pipe and driven unit.

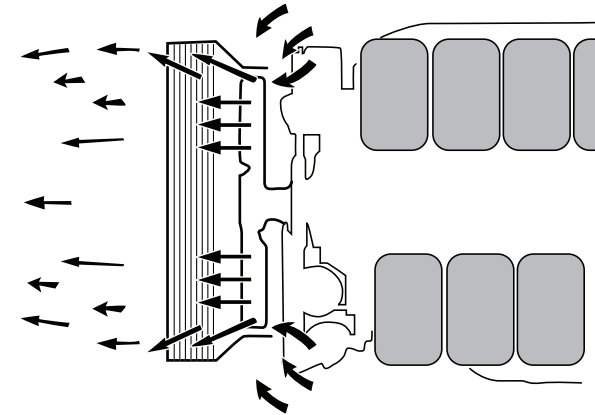

Air flow through radiator with pusher fan.

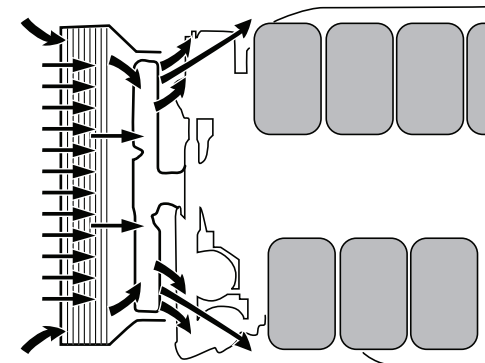

Air flow through radiator with puller fan.

340 450

340 451



Engine-mounted radiators 1.1 m² and 1.3 m²

The engine-mounted 1.1 m² radiator has been specially developed for operation in extremely dusty environments such as stone crushing plants.

The 1.1 m² radiator is intended for DC09 and DC13 engines, with an output of between 202 kW and 405 W for engines without EGR systems, and between 202 kW and 331 kW for engines with EGR systems.

The engine-mounted 1.3 m² radiator is intended for operation in normal environments.

The 1.3 m² radiator is intended for DC13 single-speed engines with a power output of between 325 kW and 487 kW.

The engine-mounted radiators are installed on the engine using reinforced brackets that are included in the cooling package. Air and coolant connections are pre-installed.

REQUIREMENT!

An engine-mounted radiator must not be allowed to hang freely. A beam should be placed under the radiator during installation.

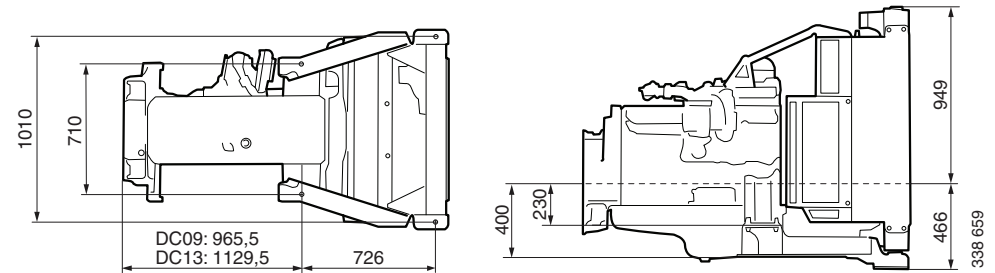

Engine-mounted radiator 1.1 m² for DC09 and DC13.

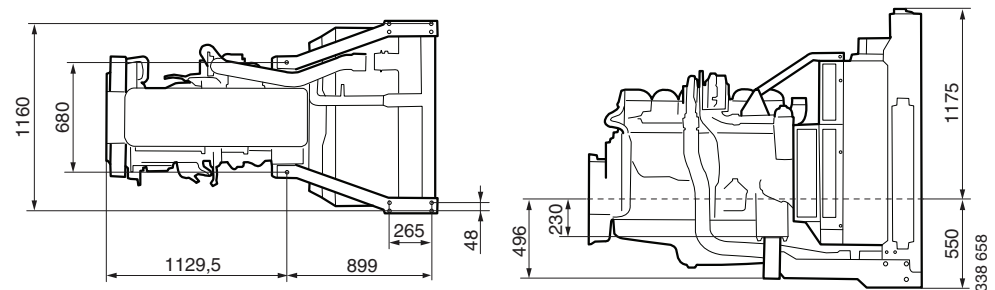

Engine-mounted radiator 1.3 m² for DC13 (single-speed engines).



Cooling capacity

In order to determine the safety margin, the actual coolant temperature (t) must be measured at the outlet from the thermostat housing when the engine is running at full power with fully open thermostats. The thermostats should be blocked into the open position in accordance with the instructions in following section.

Then calculate T max., the highest ambient temperature the engine can work in at maximum load, using the following formula:

$$T \text{ max.} = L - t + T$$

where

L = Alarm limit for coolant temperature

T = Ambient temperature during testing

t = Actual coolant temperature at full power.

T max. = Maximum ambient temperature which the engine can work in without an alarm for high engine temperature.

Determine the safety margin by comparing the resulting "T max" with the ambient temperature for which the engine installation is designed. The margin should always be greater than 5°C to compensate for radiator clogging.



Thermostat

The engines are equipped with a dual thermostat to reduce the risk of pulsation with large amounts of coolant. The opening temperature for the thermostat that regulates bypass is 80°C while the temperature for the other thermostat is 87°C. The operating range of the thermostat, i.e. the difference between a closed and fully open thermostat, is 15°C.

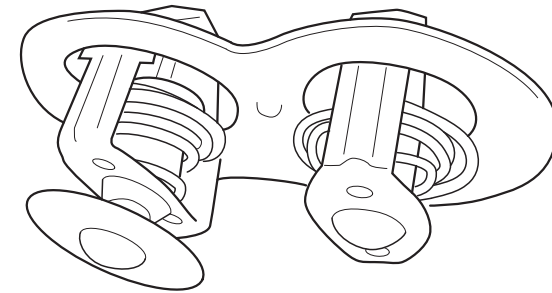

Thermostat.

336 569



Connecting a cab heater

An external heating system such as a cab heater can be connected to the engine coolant circuit as shown in the illustrations.

A cab heater must be equipped with a drain tap at the lowest point and venting at the highest point. Scania recommends positioning the expansion tank in the cooling system higher than an external heating system.

1. Connecting the intake line.
2. Connecting the return line.

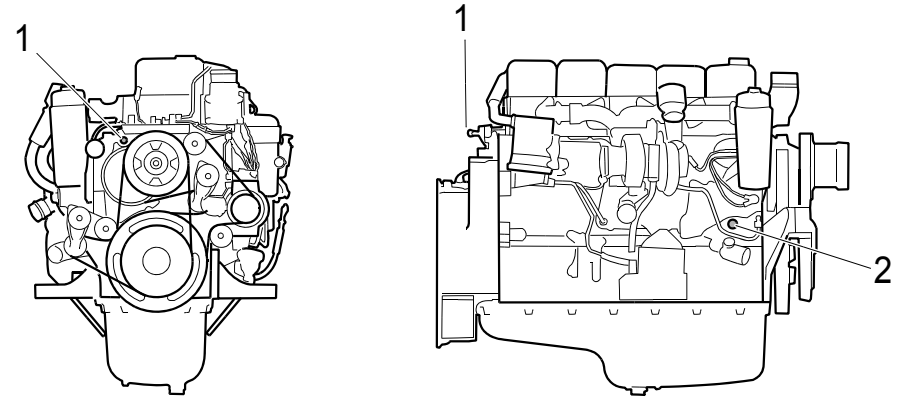

338 660

DC09, DC13.

1. M18x1.5 or Ø 16 mm hose.
2. M22x1.5 or Ø 16 mm hose.

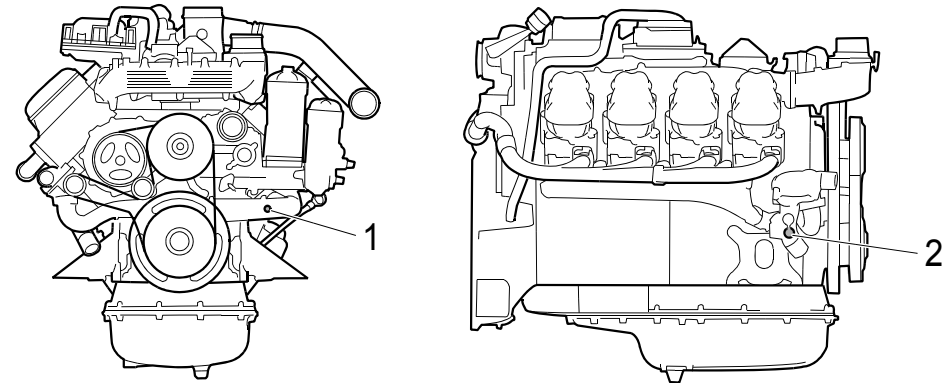

334 280

DC16.

Both the connections: M18x1.5 or Ø 16 mm hose



Transmission oil cooling

If it is necessary to cool the transmission oil using the engine cooling system, the cooling system must be designed to ensure sufficient capacity.

It is sometimes necessary to route the engine bypass pipe through the external oil cooler.

The heat output to be conducted away from the transmission can be quite large and must therefore be taken into account when designing the engine cooling system.

The installation should be constructed with coolant connection lines which are as short as possible. The connection pipes should be dimensioned so that the pressure drop is kept to a minimum, i.e. sufficient diameter and few sharp bends.

Connecting a transmission oil cooler

Oil coolers for the driven unit or transmission can be connected to the engine cooling system in either of two ways:

- The oil cooler is connected between the engine's rear coolant pipe and an external thermostat. This is recommended when the cooling requirement for the oil cooler is as great or greater than the engine cooling requirement. The retarder oil cooler is an example of this.
- The oil cooler is connected between the engine radiator and the suction side of the coolant pump. There is then no circulation through the oil cooler before the thermostat has opened, however, by installing an external thermostat and connecting the by-pass pipe upstream of the oil cooler this can be avoided.

This system is not a primary recommendation, but can be employed when the cooling requirement for the driven unit is not so great and corresponds to actual engine output. Hydraulic oil coolers and transmission oil coolers are examples of this.

DC09 and DC13

The figure shows 2 different options for connecting an oil cooler on DC09 and DC13.

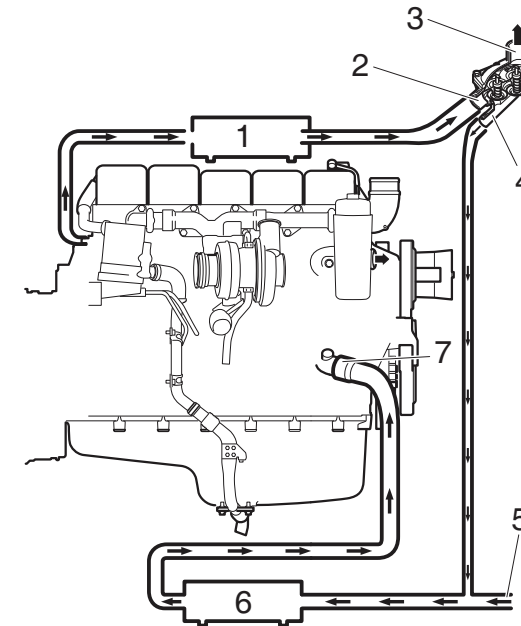

1. Large retarder type oil cooler (recommended).
2. Outlet from engine.
3. Outlet to radiator.
4. Bypass line.
5. From radiator.
6. Small oil cooler.
7. Intake to engine.



DC16

On the DC16 the oil cooler must be connected between the engine's rear coolant pipe and the engine-mounted external thermostat as shown in the figure. This is the only connection option which ensures a 100% coolant flow irrespective of how much the thermostat is open.

Note:

The engine must be ordered from the factory with an external thermostat.

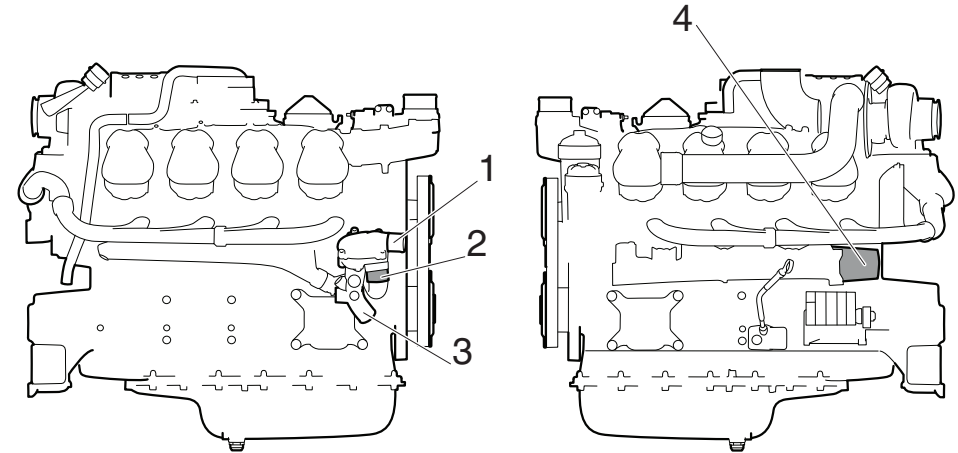

1. Outlet to radiator.
2. Intake from oil cooler.
3. Intake from radiator.
4. Outlet to oil cooler.

332 920



Immersion heater

If required, the engines can be supplied with an electric immersion heater. The immersion heater can be selected with or without integrated thermostat. The thermostat is set to a thoroughly tested temperature to ensure sufficient self-circulation. It also prevents the temperature from becoming so high that oil film on e.g. the piston and cylinder liner evaporates or dries.

For DC09 and DC13 both immersion heaters have a power output of 1,500 W and are available for either 115 V or 230 V electrical power networks.

For DC16, immersion heaters are available with a thermostat with 2 power levels: 500 or 1,500 W. Choice of power depends primarily on how cold it can be around the engine. The available power supply system can also be a key factor when selecting power. Immersion heaters are available for either 115 V or 230 V power supply systems.

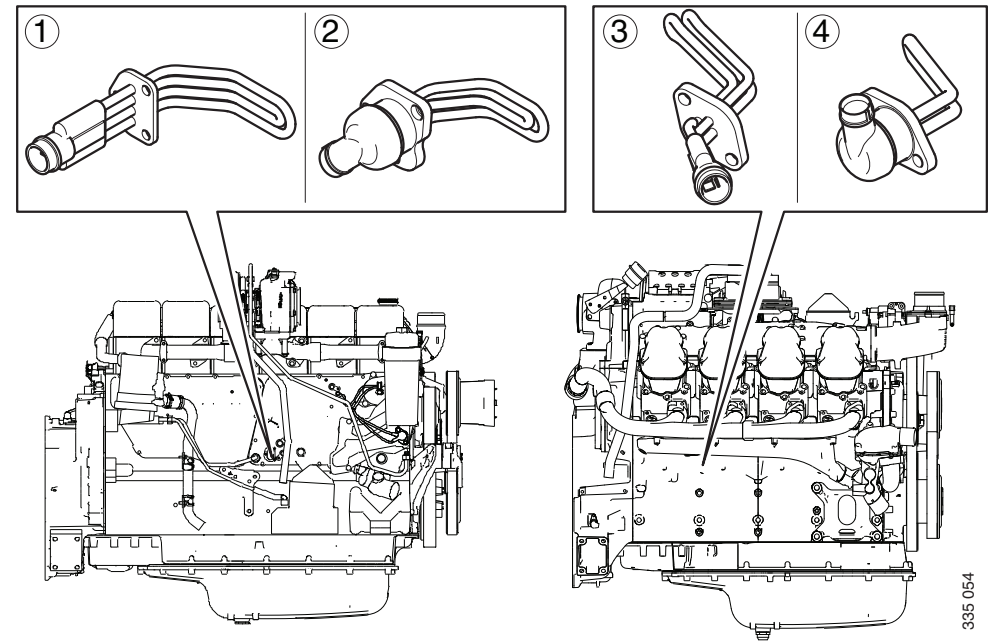

Immersion heater:

- 1. Without thermostat for DC09 and DC13.*
- 2. With thermostat for DC09 and DC13.*
- 3. Without thermostat for DC16.*
- 4. With thermostat for DC16.*

335 054



Multi-engine installation with common cooling system

In multi-engine installations, the engines can be connected to a common external cooling system following the outline diagram on the next page. A system like this must be dimensioned and planned as follows:

- The capacity of the radiator should be well matched to the number of engines in the engine installation and the overall coolant volume of the system. It is possible to use a heat exchanger instead of radiators. This is then connected to an existing cooling/heating installation in the building.
- The expansion tank should be dimensioned for an expansion volume of about 3% and a reserve volume of about 5% of the total coolant volume. The reserve volume should always be at least 10 litres.
- There must be venting at the highest point in the pipe directly downstream of the thermostat housing and on the venting manifold on the cylinder heads.
- There must also be a bleed pipe to the radiator inlet pipe. This must be connected to the pipe at the highest point upstream of the radiator. A static line pipe should be routed from the expansion tank to the suction side of the coolant pump. The outer diameter of the pipe should be a minimum of 25 mm for DC09 and DC13 and a minimum of 32 mm for DC16.
- All bleed pipes should be connected to the expansion tank below the coolant level.
- The expansion tank must not be placed higher than 8.5 m above the engine coolant pumps to avoid the pressure in their seals becoming too great.
- An extra circulation pump should be installed in the system if there is a risk of a vacuum greater than 0.1 bar forming on the suction side of the coolant pumps.
- Circulation pump capacity should be equal to the maximum total flow when all engines are running.
- Systems with an extra circulation pump should have an extra external bypass pipe with a check valve (broken line in diagram) to reduce the coolant flow through an engine which is not operating.

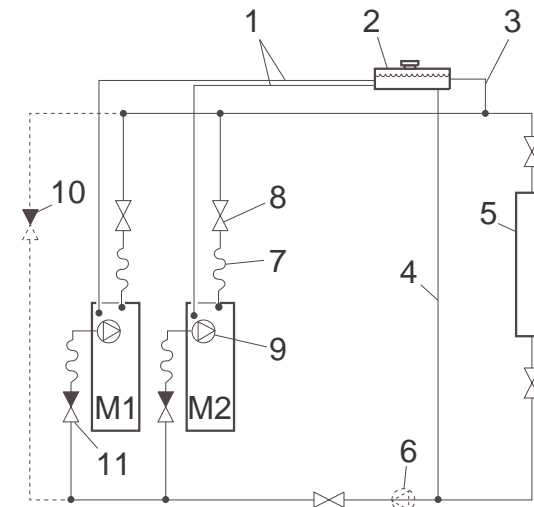

Outline diagram of cooling system in multi-engine installations.

1. Bleed pipe to expansion tank.
2. Expansion tank.
3. Bleed pipe from radiator.
4. Static line pipe.
5. Radiator or heat exchanger.
6. Extra circulation pump. Only on long lines with a large pressure drop.
7. Flexible hose.
8. Shut-off valve.
9. Engine coolant pump.
10. External pipe with check valve. Only for systems with an auxiliary circulation pump.
11. Check valve in the engine intake. Only for systems without an auxiliary circulation pump.



- Systems without an extra circulation pump should have check valves in the inlet pipes to the engines to prevent circulation in a stationary engine.
- The connections to the engine may be flexible hoses. However, flexible hoses should be used as little as possible as they can cause temperature oscillation.
- There should be shut-off valves as shown in the outline diagram to facilitate maintenance on the system.



Filling coolant

The fitter must ensure it is possible to top up coolant.



IMPORTANT!

It is not permissible to fill large amounts of coolant via the expansion tank. Filling via the expansion tank leads to air pockets in the cooling system, which can damage the coolant pump shaft seal, among other things.

Never fill a large amount of cold coolant in a hot engine. There is great risk of cracks forming in the cylinder block and cylinder heads.

When the cooling system has been drained: Use coolant trolley 588 540, coolant pump 2 443 679 or other suitable equipment, to fill with coolant through the drain valve on the cylinder block.

Start the engine when the cooling system has been filled. Allow the engine to run for a while. Then check the coolant level and top up with coolant via the expansion tank as necessary.

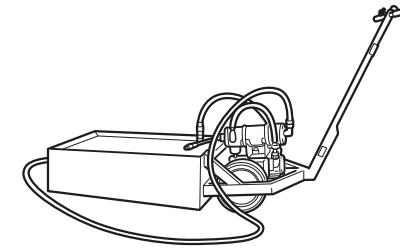

Coolant trolley 588 540.

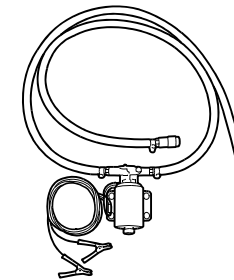

Coolant pump 2 443 679.

337 371

360 625



The illustrations show the location of the drain valves.

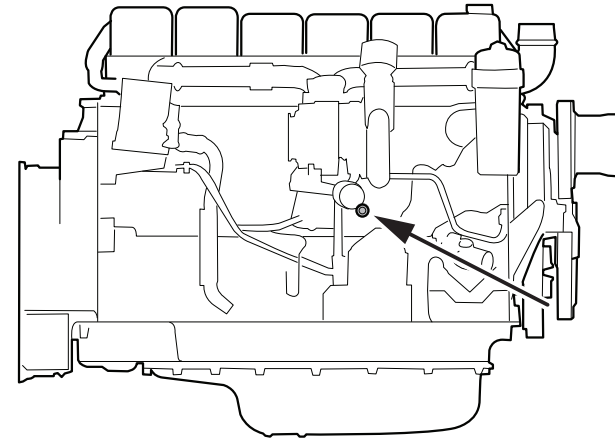

Drain valve on DC09 and DC13.

340 455

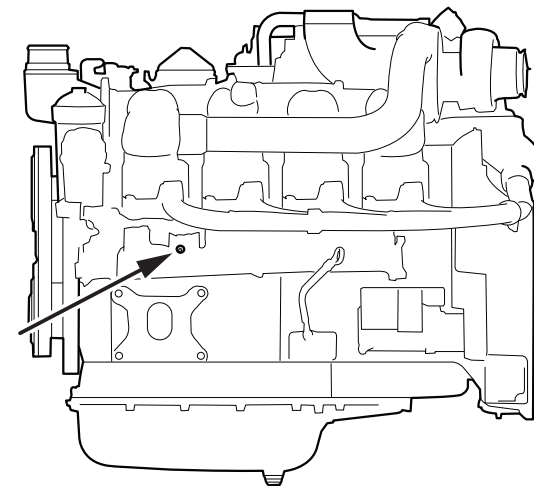

Drain valve on DC16.

340 454



Installation instructions for the cooling system

Protective casing for the 1.1 m² cooling package

Item	Part No.	Note	Qty	Designation
1	2 185 779		1	Protection mesh
	812 515	M8x16	6	Flange screw
	812 502	M6x16	6	Flange screw
2	2 074 871		1	Protection mesh
3	2 067 705		1	Protection mesh
	812 502	M6x16	4	Flange screw
4	2 074 589		1	Protection mesh
	812 515	M8x16	4	Flange screw
5	2 074 458		1	Protection mesh
	812 502	M6x16	4	Flange screw
6	2 424 340	Without alternator	1	Protection mesh
	812 515	M8x16	2	Flange screw
7	2 074 870		1	Protection mesh
8a	2 074 582	2 alternators	1	Protection mesh
	812 502	M6x16	3	Flange screw
8b	2 074 583	Alternator and AC compressor	1	Protection mesh
	812 502	M6x16	4	Flange screw
8c	2 074 584	1 alternator	1	Protection mesh
	812 502	M6x16	4	Flange screw

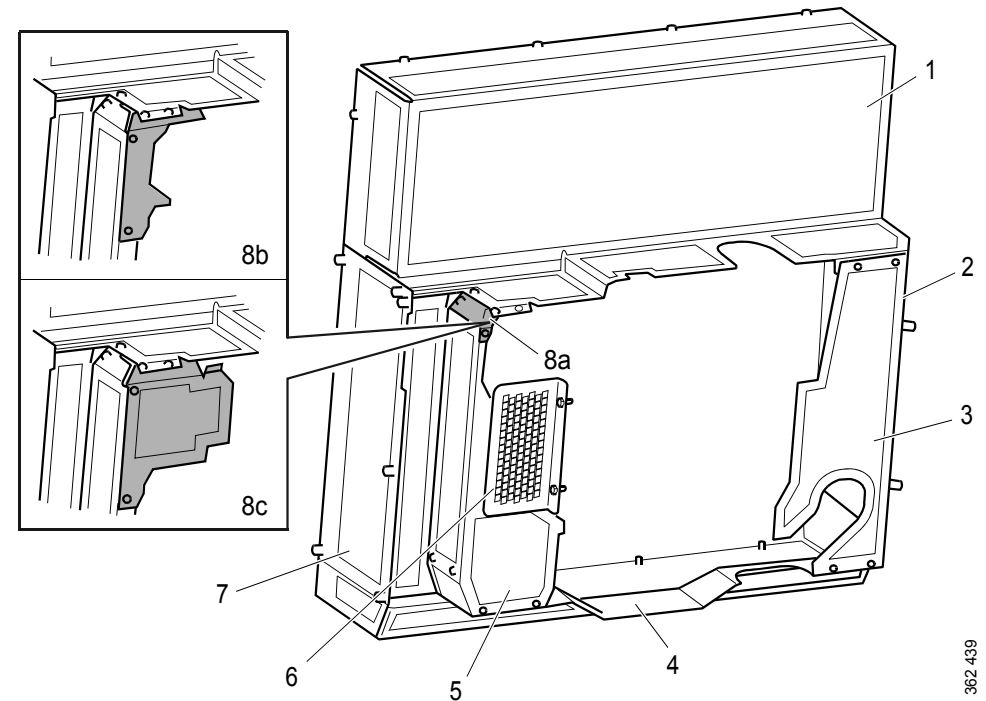

362 439



Protective casing for the 1.3 m² cooling package

Item	Part No.	Note	Qty	Designation
1	2 067 686		1	Protection mesh
	812 515	M8x16	5	Flange screw
2	2 067 707		1	Protection mesh
3	2 067 705		1	Protection mesh
	812 502	M6x16	4	Flange screw
4	2 067 703		1	Protection mesh
	812 515	M8x16	3	Flange screw
5	2 067 708		1	Protection mesh
	812 502	M6x16	3	Flange screw
6	2 424 340	Without alternator	1	Protection mesh
	812 515	M8x16	2	Flange screw
7	2 067 706		1	Protection mesh
8	1 932 338	1 alternator	1	Protection mesh
	812 502	M6x16	4	Flange screw

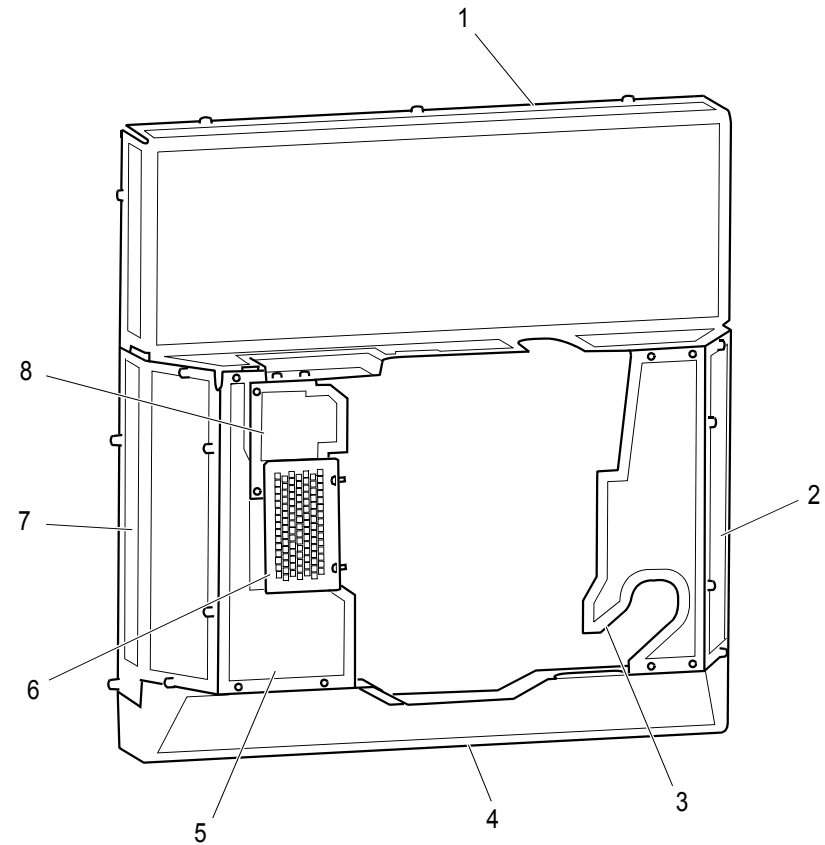

362 438



Pipes and hoses

1.1 m² radiator for the DC09 and DC13 with EGR and SCR systems

Item	Part No.	Note	Qty	Designation
1	2 184 036		1	Coolant pipe
2	1 949 304	L = 100 mm	1	Hose
	816 135	Ø 50-72 mm	2	Hose clamp
3	1 748 815	L = 100 mm	1	Hose
	1 920 953		1	Hose union
	816 131	Ø 30-45 mm	2	Hose clamp
4	2 044 003		1	Clamp
	2 043 999		1	Clamp
	812 516	M8x20	1	Flange screw
5	488 368	L = 140 mm	1	Hose
	1 527 869	Ø 88-100 mm	2	Hose clamp
6	1 883 817		1	Safety cord
	1 833 825		2	Spacing sleeve
	812 515	M8x16	2	Flange screw
7	1 931 784		1	Pipe
8	278 474		1	Hose
	816 135	Ø 50-72 mm	2	Hose clamp
9	1 931 785		1	Bracket
	812 516	M8x20	2	Flange screw

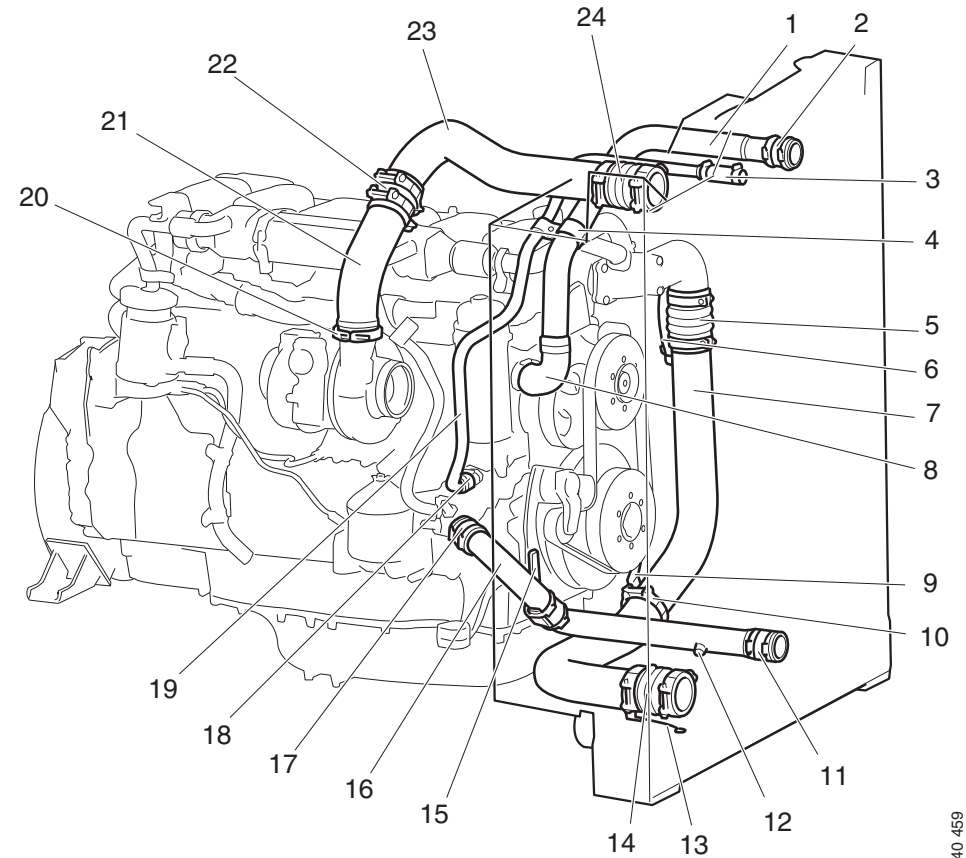

1.1 m² radiator for the DC09 and DC13 with EGR and SCR systems

340 459



Item	Part No.	Note	Qty	Designation
10	1 527 869	Ø 88-100 mm	2	Hose clamp
11	223 315	L = 100 mm	1	Hose
	816 135	Ø 50-72 mm	2	Hose clamp
12	812 372	M14x1.5x9	1	Screw plug
	2 279 228		1	Seal
13	1 833 822		1	Safety cord
	1 833 825		2	Spacing sleeve
	812 515	M8x16	2	Flange screw
14	488 368	L = 140 mm	1	Hose
	1 527 869	Ø 88-100 mm	2	Hose clamp
15	1 746 148		1	Bracket
	812 516	M8x20	2	Flange screw
	816 135	Ø 50-72 mm	2	Hose clamp
16	1 916 900		1	Coolant pipe
17	223 315	L = 100 mm	1	Hose
	816 135	Ø 50-72 mm	2	Hose clamp
18	2 184 038	L = 70 mm	1	Hose
	816 131	Ø 30-45 mm	2	Hose clamp

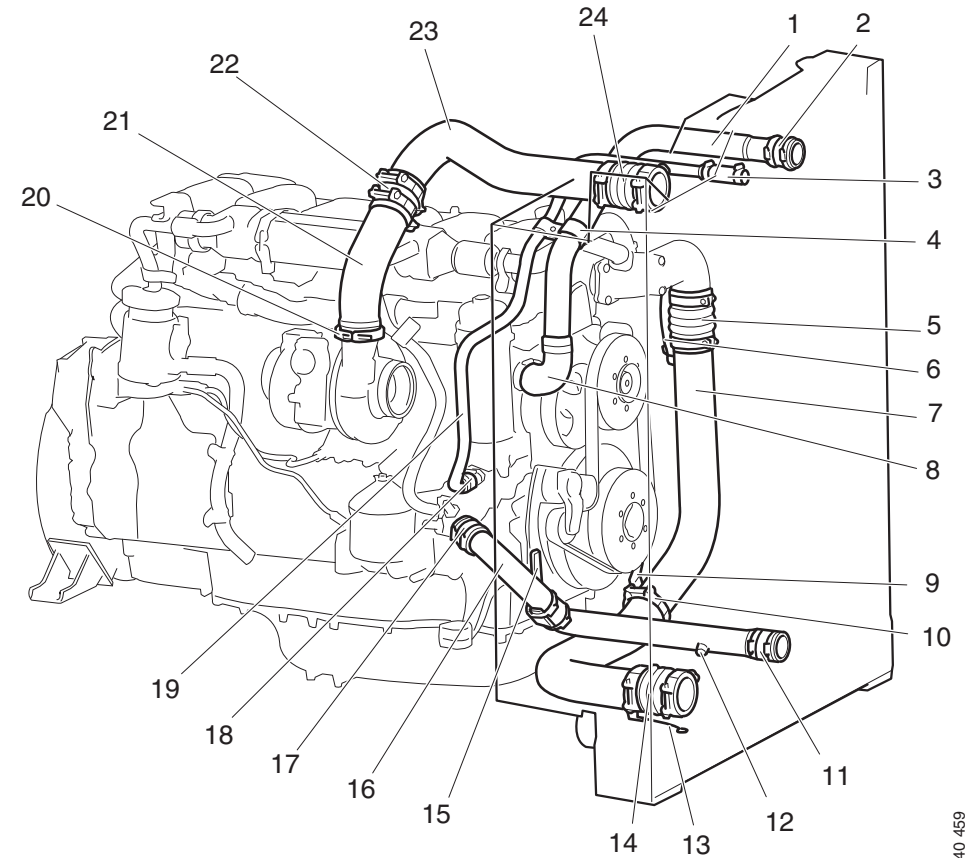

1.1 m² radiator for the DC09 and DC13 with EGR and SCR systems

340 459



Item	Part No.	Note	Qty	Designation
19	2 184 037		1	Static line pipe
20	1 439 822	DC09	1	V-clamp
	1 331 820	DC09	1	O-ring
		Ø 65.5 x 3 x 70.5		
	1 439 824	DC13	1	V-clamp
	1 353 109	DC13	1	O-ring
		Ø 79.2 x 3	1	
21	2 138 972	DC09	1	Charge air pipe
	2 190 483	DC13	1	Charge air pipe
22	1 334 822	L = 96 mm	1	Hose
	1 527 869	Ø 88-100 mm	2	Hose clamp
23	2 134 018	DC09	1	Charge air pipe
	2 112 065	DC13	1	Charge air pipe
24	488 368	L = 140 mm	1	Hose
	1 527 869	Ø 88-100 mm	2	Hose clamp

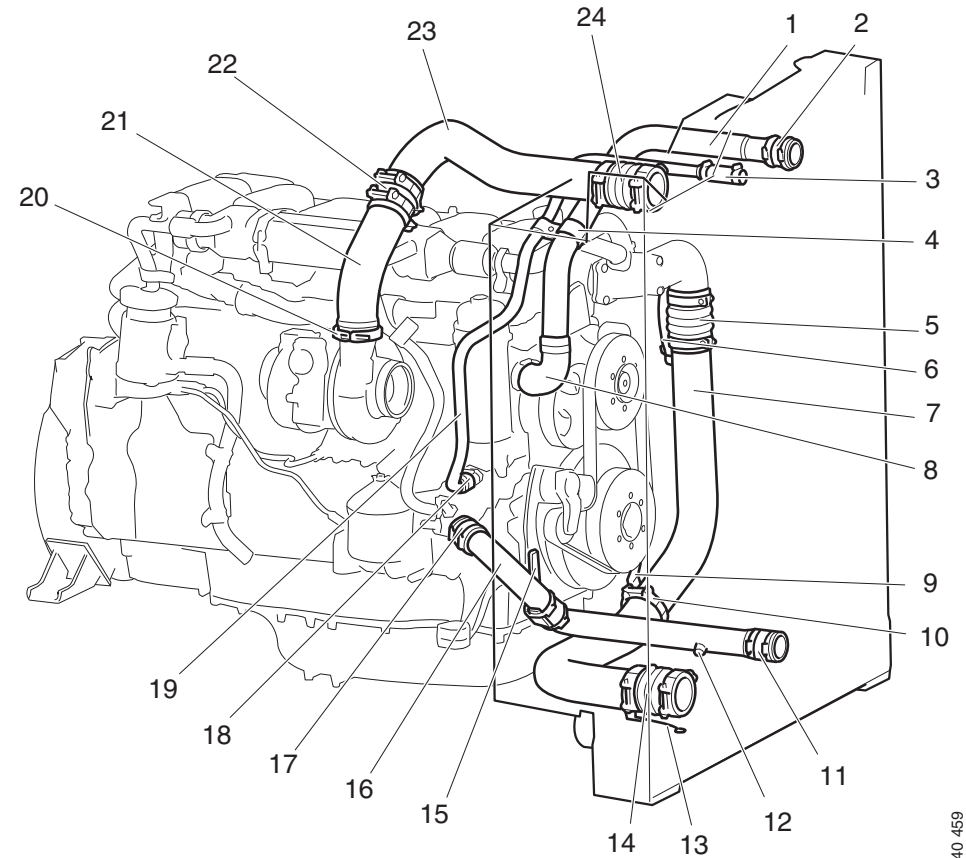

1.1 m² radiator for the DC09 and DC13 with EGR and SCR systems

340 459



1.1 m² radiator for the DC09 and DC13 with a high turbocharger and EGR system

Item	Part No.	Note	Qty	Designation
1	310 381		1	Clamp
	1 103 947		1	Washer
	812 503	M6x20	1	Flange screw
2	2 184 036		1	Coolant pipe
3	1 748 815	L = 100 mm	1	Hose
	1 920 953		1	Hose union
	816 131	Ø 30-45 mm	2	Hose clamp
4	1 949 304	L = 100 mm	1	Hose
	816 135	Ø 50-72 mm	2	Hose clamp
5	1 334 822	L = 96 mm	1	Hose
	1 527 869	Ø 88-100 mm	2	Hose clamp
6	1 833 822		1	Safety cord
	1 833 825		2	Spacing sleeve
	812 515	M8x16	2	Flange screw
7	2 044 003		1	Clamp
	2 043 999		1	Clamp
	812 516	M8x20	1	Flange screw
8	278 474		1	Hose
	816 135	Ø 50-72 mm	2	Hose clamp

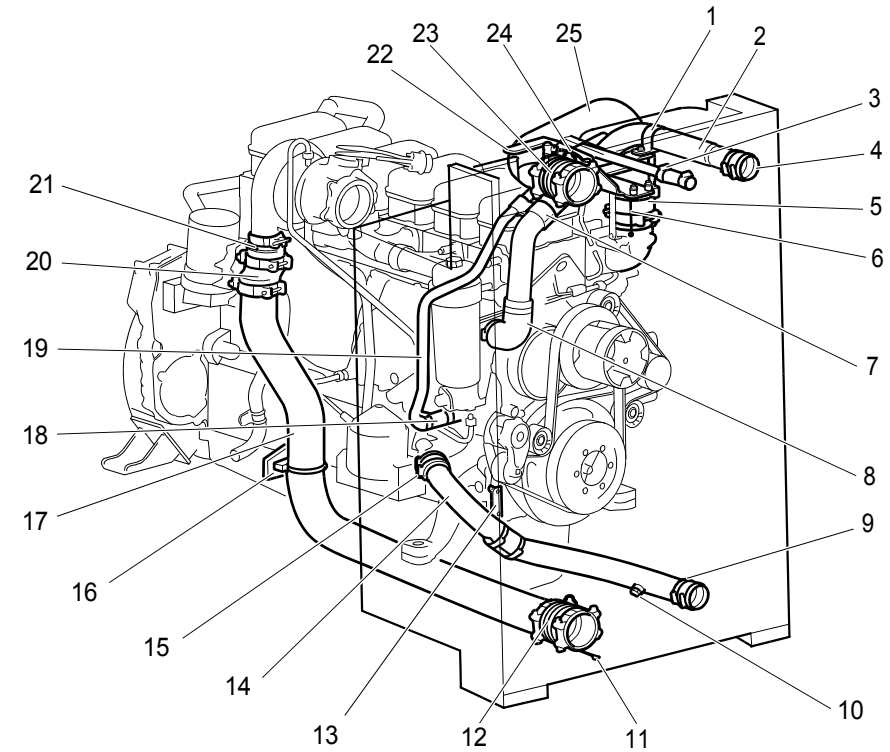

1.1 m² radiator for the DC09 and DC13 with a high turbocharger and EGR system.

368 474



Item	Part No.	Note	Qty	Designation
9	223 315	L = 100 mm	1	Hose
	816 135	Ø 50-72 mm	2	Hose clamp
10	812 372	M14x1.5x9	1	Screw plug
	2 279 228		1	Seal
11	1 883 817		1	Safety cord
	1 833 825		2	Spacing sleeve
	812 515	M8x16	2	Flange screw
12	488 368	L = 140 mm	1	Hose
	1 527 869	Ø 88-100 mm	2	Hose clamp
13	1 746 148		1	Bracket
	812 516	M8x20	2	Flange screw
	816 135	Ø 50-72 mm	2	Hose clamp
14	1 916 900		1	Coolant pipe
15	223 315	L = 100 mm	1	Hose
	816 135	Ø 50-72 mm	2	Hose clamp
16	2 046 362	DC09	1	Bracket
	2 043 265	DC13	1	Bracket
	1 927 918		1	U clamp
	812 536	DC09, M10x25	2	Flange screw
	812 516	DC13, M8x20	2	Flange screw

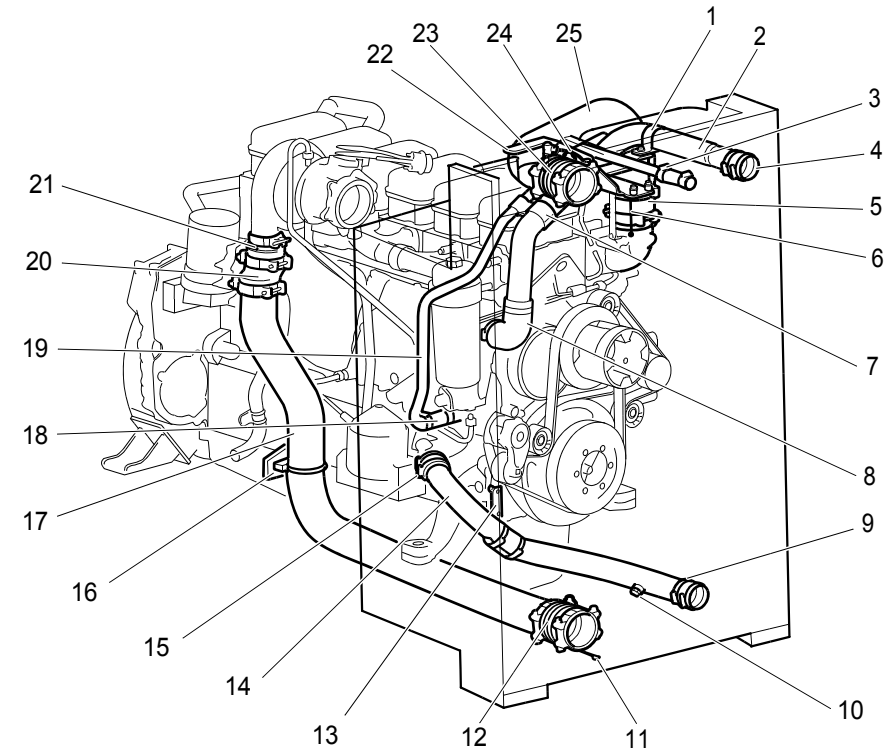

1.1 m² radiator for the DC09 and DC13 with a high turbocharger and EGR system.

368 474



Item	Part No.	Note	Qty	Designation
17	2 046 355	DC09	1	Charge air pipe
	2 043 808	DC13	1	Charge air pipe
18	2 184 038	L = 100 mm	1	Hose
	816 131	Ø 30-45 mm	2	Hose clamp
19	2 184 037		1	Static line pipe
20	1 334 822	L = 96 mm	1	Hose
	1 527 869	Ø 88-100 mm	2	Hose clamp
21	1 533 713		1	Charge air pipe
	1 439 822		1	V-clamp
	1 331 820	Ø 65.5 x 3 x 70.5	1	O-ring
22	2 134 295		1	Bracket
	812 520	M8x35	4	Flange screw
	1 347 255		4	Spacer
23	488 368	L = 140 mm	1	Hose
	1 527 869	Ø 88-100 mm	2	Hose clamp
24	1 883 817		1	Safety cord
	1 833 825		2	Spacing sleeve
	812 515	M8x16	2	Flange screw
25	1 746 183		1	Charge air pipe

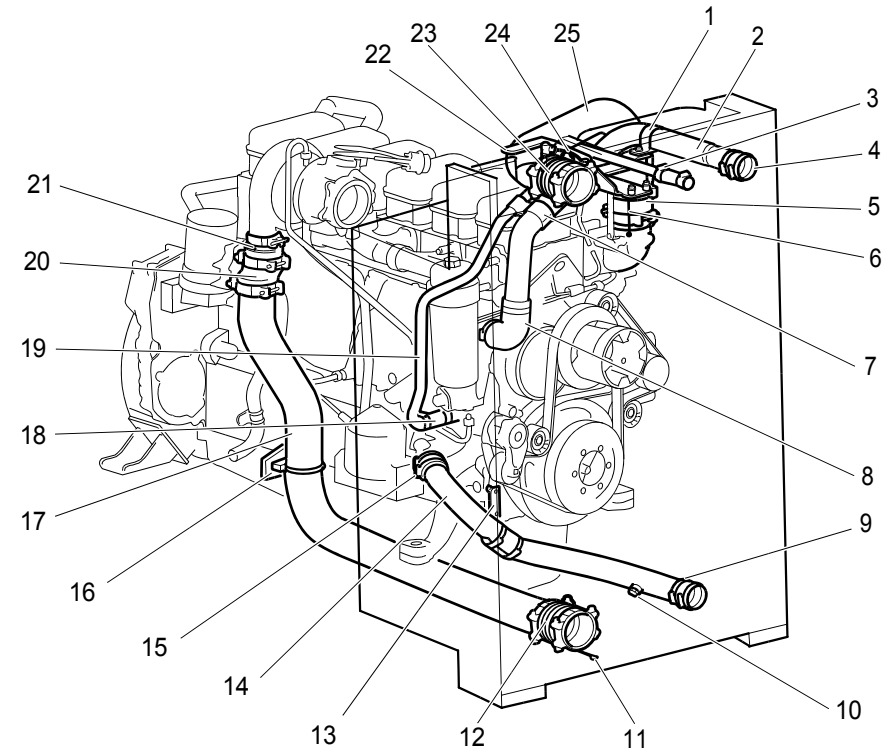

1.1 m² radiator for the DC09 and DC13 with a high turbocharger and EGR system.

368 474



1.1 m² radiator for the DC09 with a high turbocharger

Item	Part No.	Note	Qty	Designation
1	483 129		1	Charge air pipe
	1 439 822		1	V-clamp
	1 331 820	Ø 65.5 x 3 x 70.5	1	O-ring
2	1 334 822	L = 96 mm	1	Hose
	1 527 869	Ø 88-100 mm	2	Hose clamp
3	2 207 851		1	Charge air pipe
4	1 927 918		1	U clamp
5	2 134 295		1	Bracket
	812 520	M8x35	4	Flange screw
	1 347 255		4	Spacer
6	488 368	L = 140 mm	1	Hose
	1 527 869	Ø 88-100 mm	2	Hose clamp
7	310 381		1	Clamp
	1 103 947		1	Washer
	812 503	M6x20	1	Flange screw
8	2 184 036		1	Coolant pipe
9	1 748 815	L = 100 mm	1	Hose
	1 920 953		1	Hose union
	816 131	Ø 30-45 mm	2	Hose clamp
10	1 949 304	L = 100 mm	1	Hose
	816 135	Ø 50-72 mm	2	Hose clamp

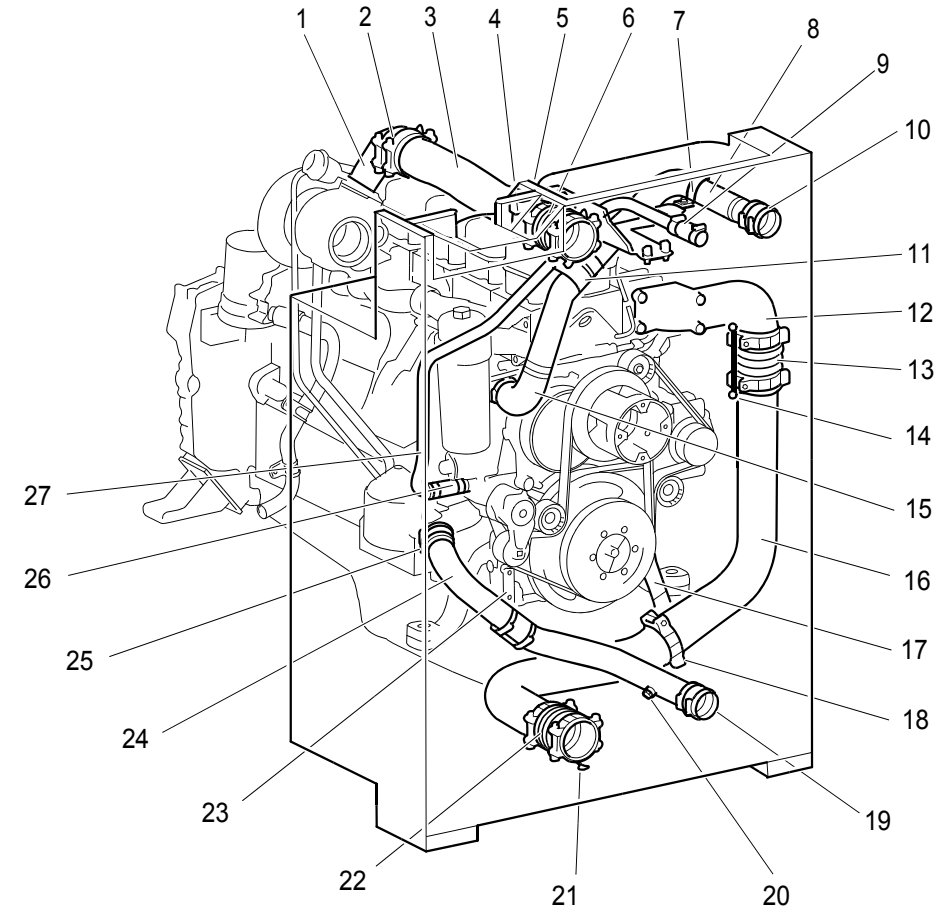

1.1 m² radiator for the DC09 with a high turbocharger.

368 472



Item	Part No.	Note	Qty	Designation
11	2 044 003		1	Clamp
	2 043 999		1	Clamp
	812 516	M8x20	1	Flange screw
12	1 930 679		1	Inlet pipe
13	488 368	L = 140 mm	1	Hose
	1 527 869	Ø 88-100 mm	2	Hose clamp
14	1 883 817		1	Safety cord
	1 833 825		2	Spacing sleeve
	812 515	M8x16	2	Flange screw
15	278 474		1	Hose
	816 135	Ø 50-72 mm	2	Hose clamp
16	1 931 784		1	Pipe
17	1 931 785		1	Bracket
	812 516	M8x20	2	Flange screw
18	1 527 869	Ø 88-100 mm	1	Hose clamp
19	223 315	L = 100 mm	1	Hose
	816 135	Ø 50-72 mm	2	Hose clamp

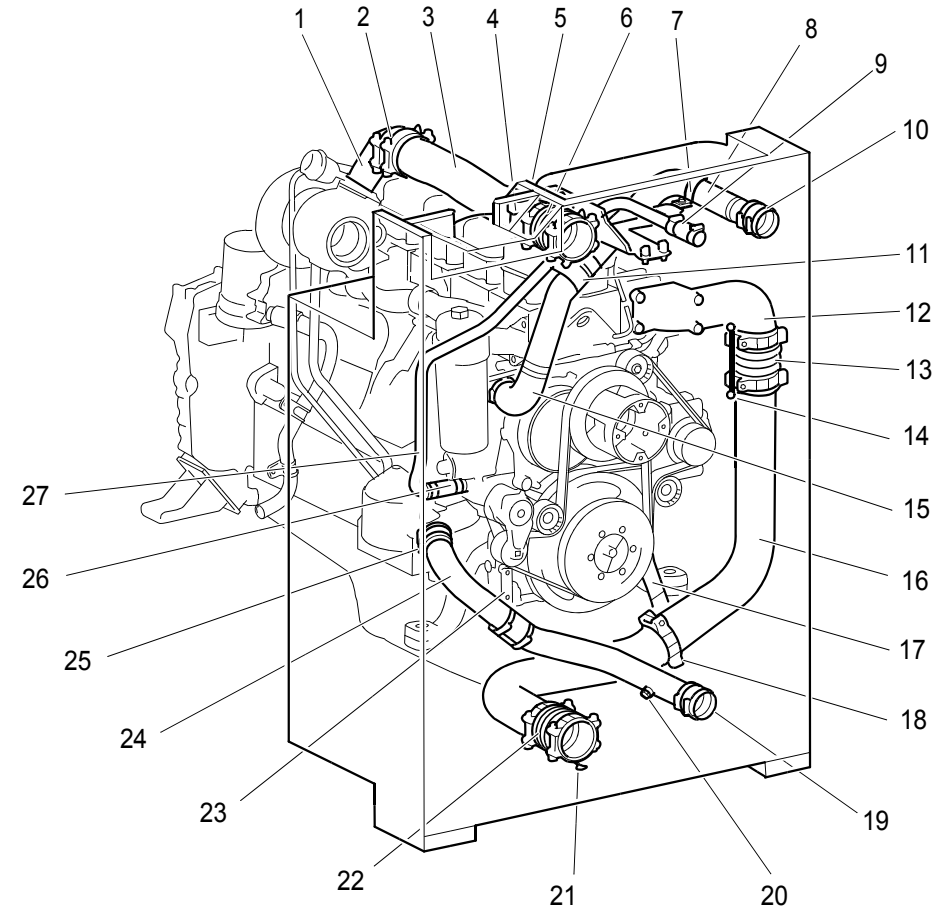

1.1 m² radiator for the DC09 with a high turbocharger.

368 472



Item	Part No.	Note	Qty	Designation
20	812 372	M14x1.5x9	1	Screw plug
	2 279 228		1	Seal
21	1 833 822		1	Safety cord
	1 833 825		2	Spacing sleeve
	812 515	M8x16	2	Flange screw
22	488 368	L = 140 mm	1	Hose
	1 527 869	Ø 88-100 mm	2	Hose clamp
23	1 746 148		1	Bracket
	812 516	M8x20	2	Flange screw
	816 135	Ø 50-72 mm	2	Hose clamp
24	1 916 900		1	Coolant pipe
25	223 315	L = 100 mm	1	Hose
	816 135	Ø 50-72 mm	2	Hose clamp
26	2 184 038	L = 100 mm	1	Hose
	816 131	Ø 30-45 mm	2	Hose clamp
27	2 184 037		1	Static line pipe

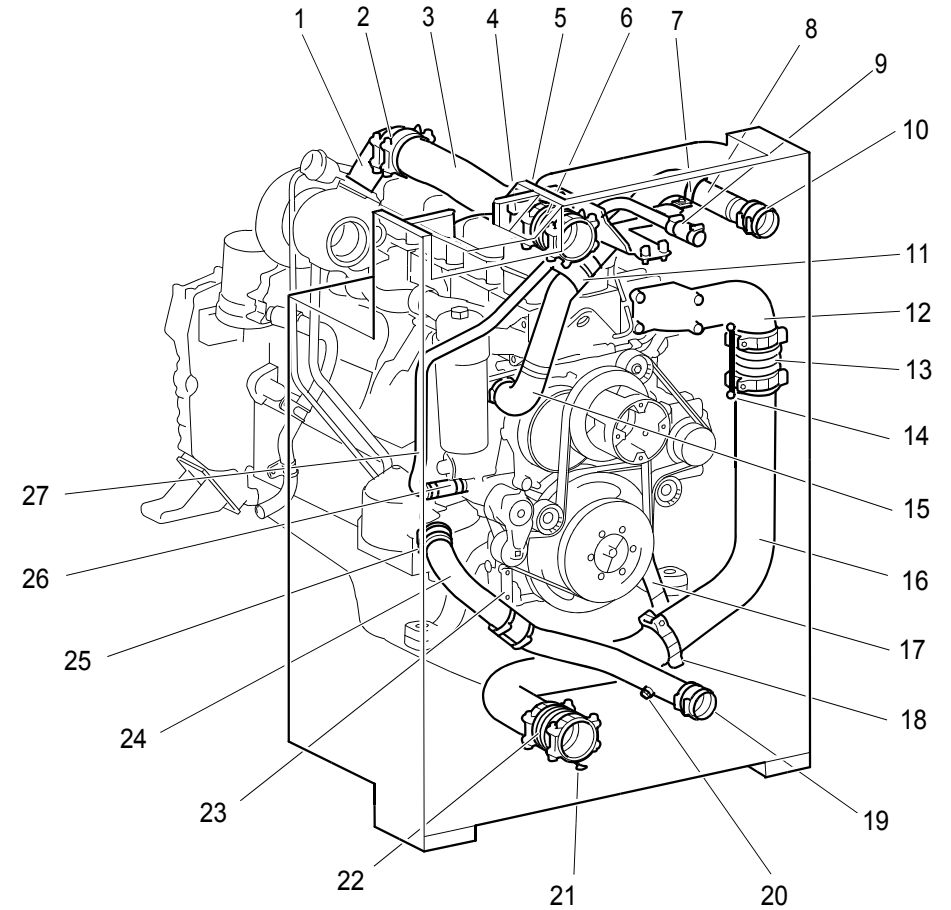

1.1 m² radiator for the DC09 with a high turbocharger.

368 472



1.1 m² radiator for the DC09 with a low turbocharger

Item	Part No.	Note	Qty	Designation
1	2 134 295		1	Bracket
	812 520	M8x35	4	Flange screw
	1 347 255		4	Spacer
2	488 368	L = 140 mm	1	Hose
	1 527 869	Ø 88-100 mm	2	Hose clamp
3	310 381		1	Clamp
	1 103 947		1	Washer
	812 503	M6x20	1	Flange screw
4	2 184 036		1	Coolant pipe
5	1 748 815	L = 100 mm	1	Hose
	1 920 953		1	Hose union
	816 131	Ø 30-45 mm	2	Hose clamp
6	1 949 304	L = 100 mm	1	Hose
	816 135	Ø 50-72 mm	2	Hose clamp
7	2 044 003		1	Clamp
	2 043 999		1	Clamp
	812 516	M8x20	1	Flange screw
8	1 930 679		1	Inlet pipe
9	488 368	L = 140 mm	1	Hose
	1 527 869	Ø 88-100 mm	2	Hose clamp

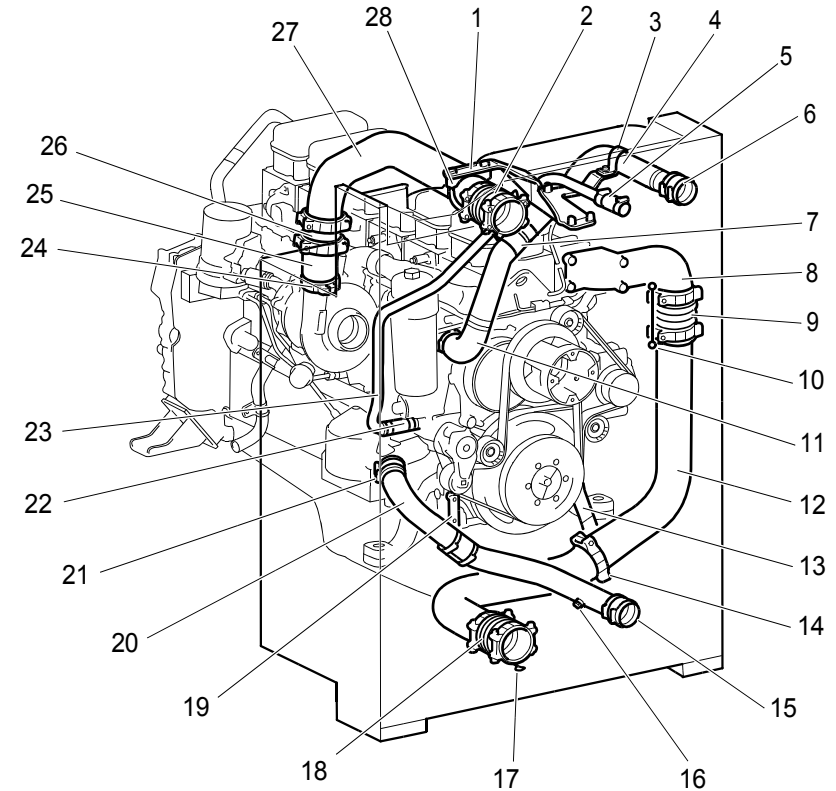

1.1 m² radiator for the DC09 with a low turbocharger.

368 476



Item	Part No.	Note	Qty	Designation
10	1 883 817		1	Safety cord
	1 833 825		2	Spacing sleeve
	812 515	M8x16	2	Flange screw
11	278 474		1	Hose
	816 135	Ø 50-72 mm	2	Hose clamp
12	1 931 784		1	Pipe
13	1 931 785		1	Bracket
	812 516	M8x20	2	Flange screw
14	1 527 869	Ø 88-100 mm	1	Hose clamp
15	223 315	L = 100 mm	1	Hose
	816 135	Ø 50-72 mm	2	Hose clamp
16	812 372	M14x1.5x9	1	Screw plug
	2 279 228		1	Seal
17	1 833 822		1	Safety cord
	1 833 825		2	Spacing sleeve
	812 515	M8x16	2	Flange screw
18	488 368	L = 140 mm	1	Hose
	1 527 869	Ø 88-100 mm	2	Hose clamp
19	1 746 148		1	Bracket
	812 516	M8x20	2	Flange screw
	816 135	Ø 50-72 mm	2	Hose clamp

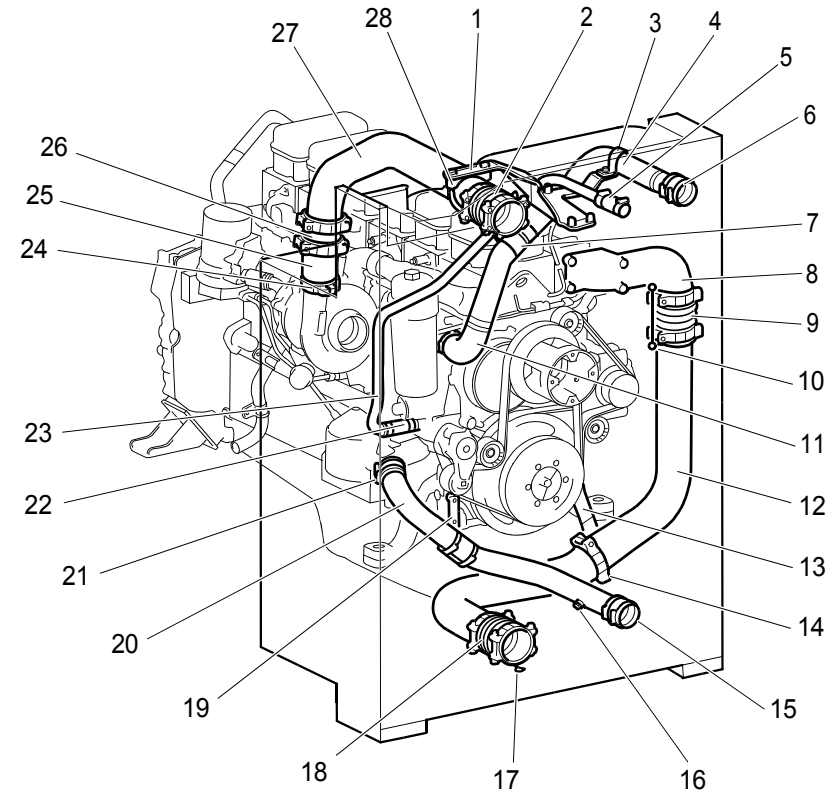

1.1 m² radiator for the DC09 with a low turbocharger.

368 476



Item	Part No.	Note	Qty	Designation
20	1 916 900		1	Coolant pipe
21	223 315	L = 100 mm	1	Hose
	816 135	Ø 50-72 mm	2	Hose clamp
22	2 184 038	L = 100 mm	1	Hose
	816 131	Ø 30-45 mm	2	Hose clamp
23	2 184 037		1	Static line pipe
24	1 439 822		1	V-clamp
	1 331 820	Ø 65.5 x 3 x 70.5	1	O-ring
25	2 138 972		1	Charge air pipe
26	1 334 822	L = 96 mm	1	Hose
	1 527 869	Ø 88-100 mm	2	Hose clamp
27	2 210 254		1	Charge air pipe
28	1 927 918		1	U clamp

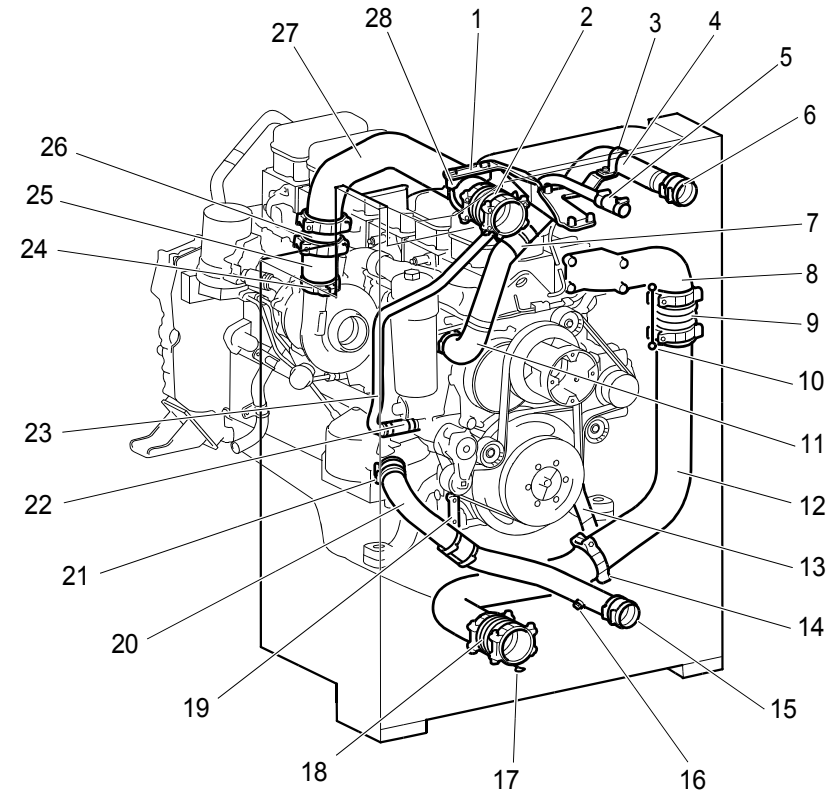

1.1 m² radiator for the DC09 with a low turbocharger.

368 476



1.1 m² radiator for the DC13 with a high turbocharger

Item	Part No.	Note	Qty	Designation
1	310 381		1	Clamp
	1 103 947		1	Washer
	812 503	M6x20	1	Flange screw
2	2 184 036		1	Coolant pipe
3	1 748 815	L = 100 mm	1	Hose
	1 920 953		1	Hose union
	816 131	Ø 30-45 mm	2	Hose clamp
4	1 949 304	L = 100 mm	1	Hose
	816 135	Ø 50-72 mm	2	Hose clamp
5	1 334 822	L = 96 mm	1	Hose
	1 527 869	Ø 88-100 mm	2	Hose clamp
6	2 044 003		1	Clamp
	2 043 999		1	Clamp
	812 516	M8x20	1	Flange screw
7	278 474		1	Hose
	816 135	Ø 50-72 mm	2	Hose clamp
8	223 315	L = 100 mm	1	Hose
	816 135	Ø 50-72 mm	2	Hose clamp
9	812 372	M14x1.5x9	1	Screw plug
	2 279 228		1	Seal

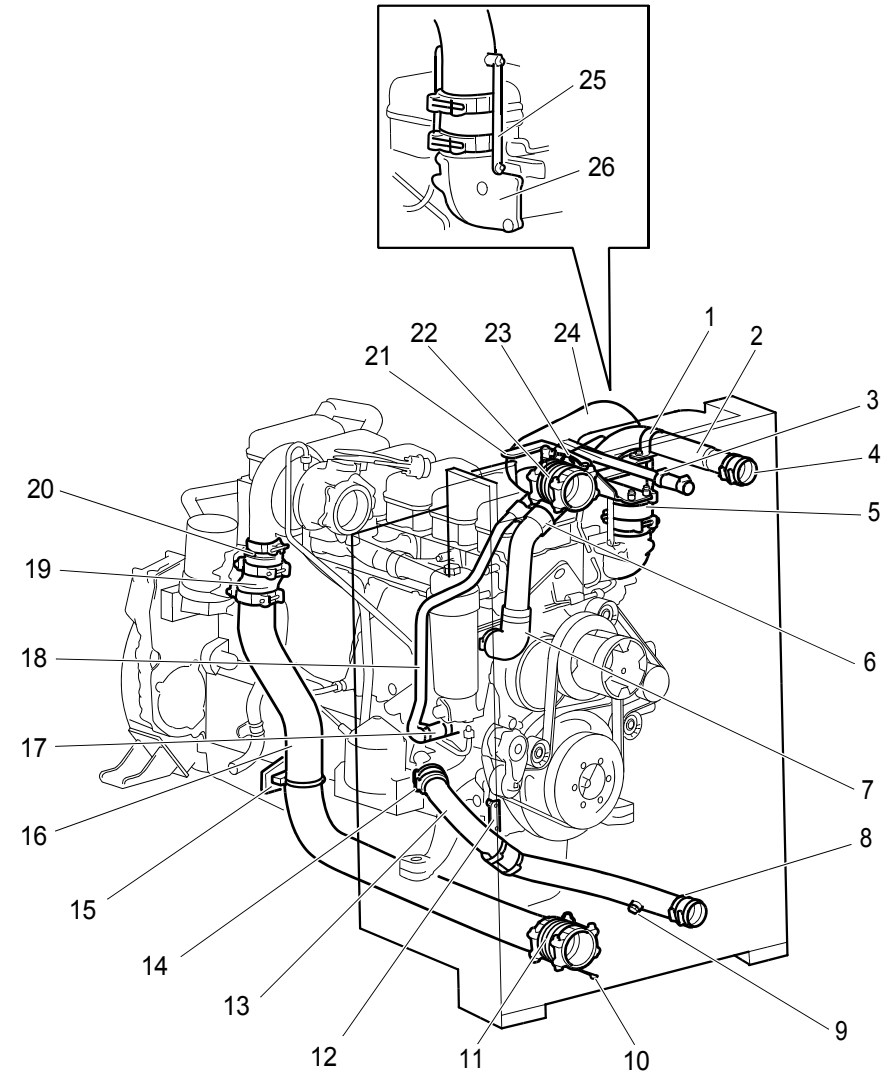

1.1 m² radiator for the DC13 with a high turbocharger.



Item	Part No.	Note	Qty	Designation
10	1 883 817		1	Safety cord
	1 833 825		2	Spacing sleeve
	812 515	M8x16	2	Flange screw
11	488 368	L = 140 mm	1	Hose
	1 527 869	Ø 88-100 mm	2	Hose clamp
12	1 746 148		1	Bracket
	812 516	M8x20	2	Flange screw
	816 135	Ø 50-72 mm	2	Hose clamp
13	1 916 900		1	Coolant pipe
14	223 315	L = 100 mm	1	Hose
	816 135	Ø 50-72 mm	2	Hose clamp
15	2 043 265		1	Bracket
	1 927 918		1	U clamp
	812 516	M8x20	2	Flange screw
16	2 043 808		1	Charge air pipe
17	2 184 038	L = 100 mm	1	Hose
	816 131	Ø 30-45 mm	2	Hose clamp
18	2 184 037		1	Static line pipe
19	1 334 822	L = 96 mm	1	Hose
	1 527 869	Ø 88-100 mm	2	Hose clamp

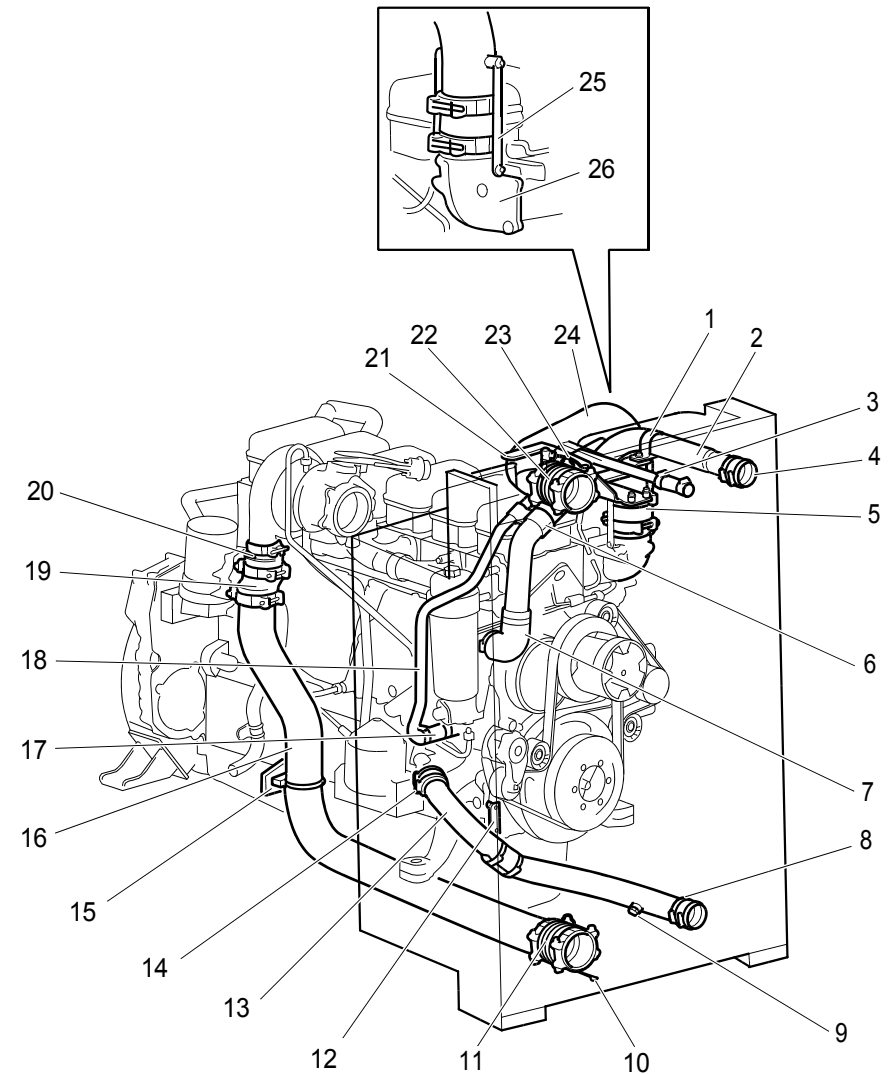

1.1 m² radiator for the DCI3 with a high turbocharger.



Item	Part No.	Note	Qty	Designation
20	1 533 713		1	Charge air pipe
	1 439 822		1	V-clamp
	1 331 820	Ø 65.5 x 3 x 70.5	1	O-ring
21	2 134 295		1	Bracket
	812 520	M8x35	4	Flange screw
	1 347 255		4	Spacer
22	488 368	L = 140 mm	1	Hose
	1 527 869	Ø 88-100 mm	2	Hose clamp
23	1 883 817		1	Safety cord
	1 833 825		2	Spacing sleeve
	812 515	M8x16	2	Flange screw
24	2 062 765		1	Charge air pipe
25	2 064 182		2	Bracket
	812 515	M8x16	4	Flange screw
26	2 062 766		1	Flange pipe

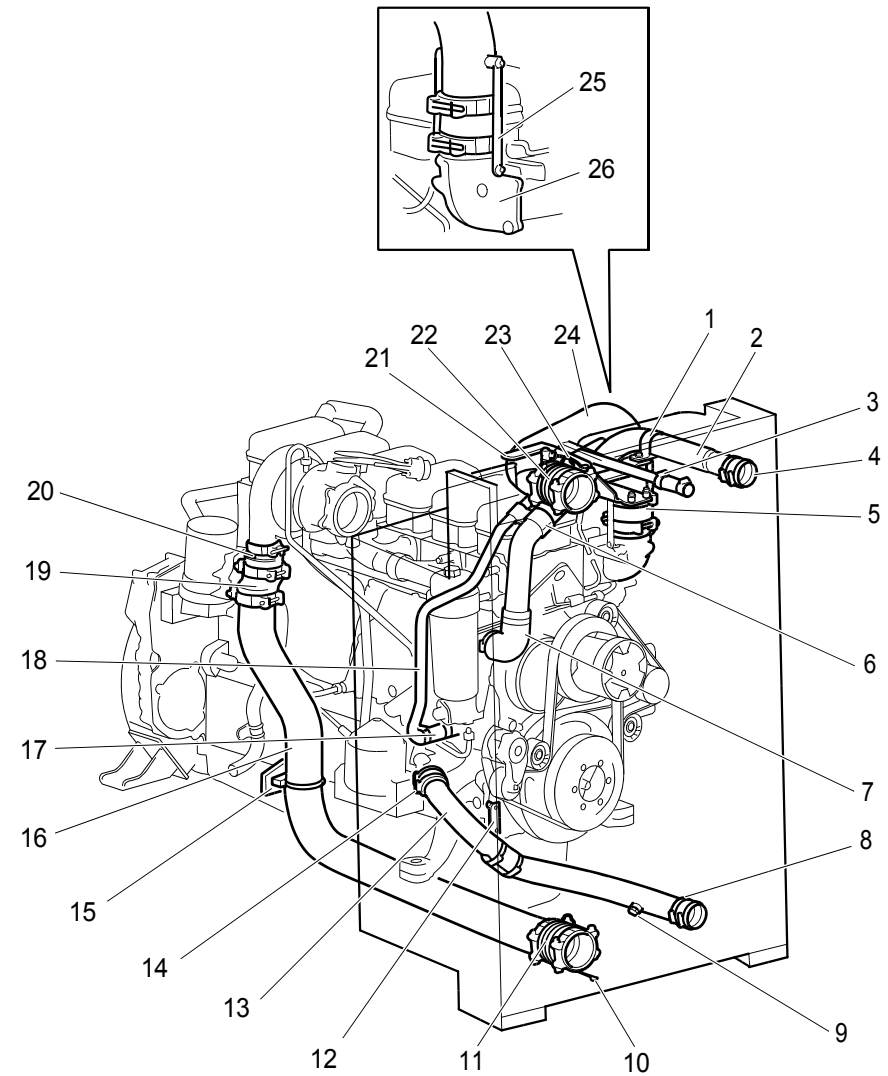

1.1 m² radiator for the DC13 with a high turbocharger.



1.1 m² radiator for the DC13 with a low turbocharger

Item	Part No.	Note	Qty	Designation
1	1 883 817		1	Safety cord
	1 833 825		2	Spacing sleeve
	812 515	M8x16	2	Flange screw
2	488 368	L = 140 mm	1	Hose
	1 527 869	Ø 88-100 mm	2	Hose clamp
3	310 381		1	Clamp
	1 103 947		1	Washer
	812 503	M6x20	1	Flange screw
4	2 184 036		1	Coolant pipe
5	1 748 815	L = 100 mm	1	Hose
	1 920 953		1	Hose union
	816 131	Ø 30-45 mm	2	Hose clamp
6	1 949 304	L = 100 mm	1	Hose
	816 135	Ø 50-72 mm	2	Hose clamp
7	2 044 003		1	Clamp
	2 043 999		1	Clamp
	812 516	M8x20	1	Flange screw
8	1 930 679		1	Inlet pipe
9	488 368	L = 140 mm	1	Hose
	1 527 869	Ø 88-100 mm	2	Hose clamp

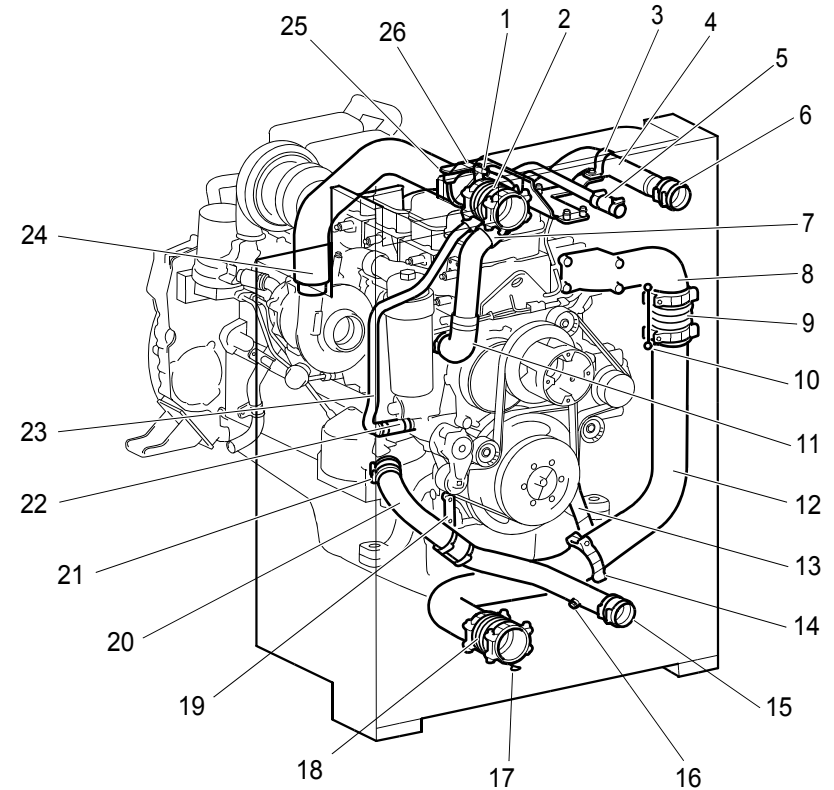

1.1 m² radiator for the DC13 with a low turbocharger.

368 473



Item	Part No.	Note	Qty	Designation
10	1 883 817		1	Safety cord
	1 833 825		2	Spacing sleeve
	812 515	M8x16	2	Flange screw
11	278 474		1	Hose
	816 135	Ø 50-72 mm	2	Hose clamp
12	1 931 784		1	Pipe
13	1 931 785		1	Bracket
	812 516	M8x20	2	Flange screw
14	1 527 869	Ø 88-100 mm	1	Hose clamp
15	223 315	L = 100 mm	1	Hose
	816 135	Ø 50-72 mm	2	Hose clamp
16	812 372	M14x1.5x9	1	Screw plug
	2 279 228		1	Seal
17	1 833 822		1	Safety cord
	1 833 825		2	Spacing sleeve
	812 515	M8x16	2	Flange screw
18	488 368	L = 140 mm	1	Hose
	1 527 869	Ø 88-100 mm	2	Hose clamp
19	1 746 148		1	Bracket
	812 516	M8x20	2	Flange screw
	816 135	Ø 50-72 mm	2	Hose clamp

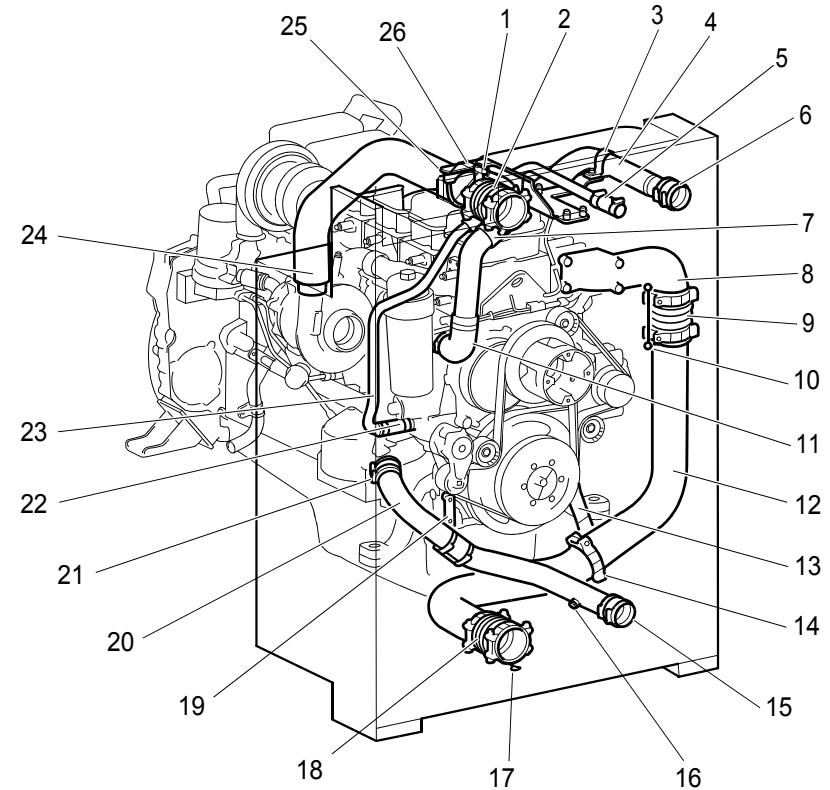

1.1 m² radiator for the DC13 with a low turbocharger.

368 473



Item	Part No.	Note	Qty	Designation
20	1 916 900		1	Coolant pipe
21	223 315	L = 100 mm	1	Hose
	816 135	Ø 50-72 mm	2	Hose clamp
22	2 184 038	L = 100 mm	1	Hose
	816 131	Ø 30-45 mm	2	Hose clamp
23	2 184 037		1	Static line pipe
24	1 927 915		1	Charge air pipe
25	1 927 918		1	U clamp
26	2 134 295		1	Bracket
	812 520	M8x35	4	Flange screw
	1 347 255		4	Spacer

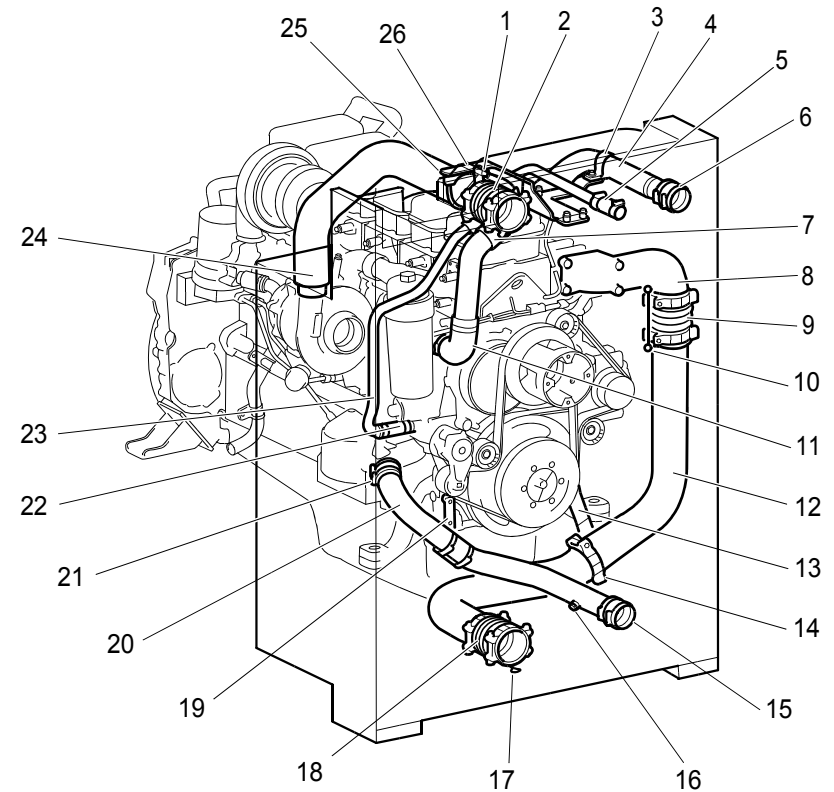

1.1 m² radiator for the DC13 with a low turbocharger.

368 473



1.3 m² radiator for the DC13

Item	Part No.	Note	Qty	Designation
1	1 746 161	DC13 with EGR	1	Charge air pipe
	1 922 705	DC13 without EGR	1	Charge air pipe
2	1 503 691	L = 140 mm	1	Hose
	1 495 780	Ø 100-116 mm	2	Hose clamp
3	1 833 822		1	Safety cord
	1 833 825		2	Spacing sleeve
	812 515	M8x16	2	Flange screw
4	1 833 822	DC13 with EGR	1	Safety cord
	1 833 825	DC13 with EGR	2	Spacing sleeve
	812 515	DC13 with EGR, M8x16	2	Flange screw
5	1 334 822	L = 96 mm	1	Hose
	1 527 869	Ø 88-100 mm	2	Hose clamp
6	816 135	Ø 50-72 mm	2	Hose clamp
7	310 381		1	Clamp
	1 103 947		1	Washer
	812 503	M6x20	1	Flange screw
8	278 474		1	Hose
	816 135	Ø 50-72 mm	2	Hose clamp
9	1 746 148		1	Bracket
	812 516	M8x20	2	Flange screw
	816 135	Ø 50-72 mm	2	Hose clamp

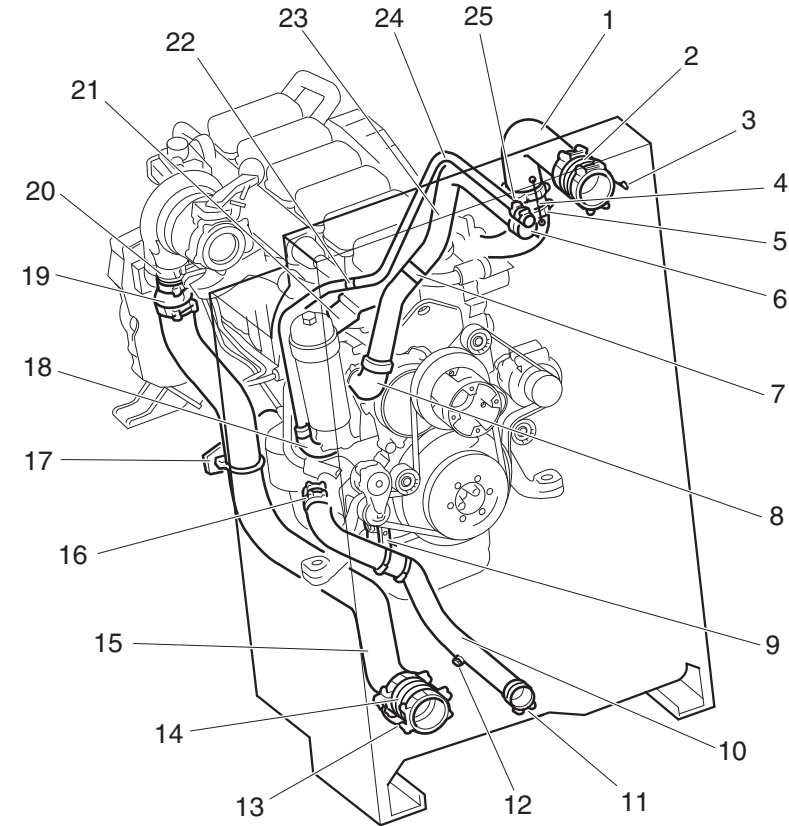

1.3 m² radiator for the DC13

334 702



Item	Part No.	Note	Qty	Designation
10	2 000 416		1	Coolant pipe
11	816 135	Ø 50-72 mm	1	Hose clamp
12	812 372	M14x1.5x9	1	Screw plug
	2 279 228		1	Seal
13	1 833 822		1	Safety cord
	1 833 825		2	Spacing sleeve
	812 515	M8x16	2	Flange screw
14	1 503 691	L = 140 mm	1	Hose
	1 495 780	Ø 100-116 mm	2	Hose clamp
15	2 226 013		1	Charge air pipe
16	223 315	L = 100 mm	1	Hose
	816 135	Ø 50-72 mm	2	Hose clamp
17	2 043 265		1	Bracket
	1 927 918		1	U clamp
	812 516	M8x20	2	Flange screw
18	1 857 405		1	Hose
	816 131	Ø 30-45 mm	2	Hose clamp
19	1 334 822	L = 96 mm	1	Hose
	1 527 869	Ø 88-100 mm	2	Hose clamp

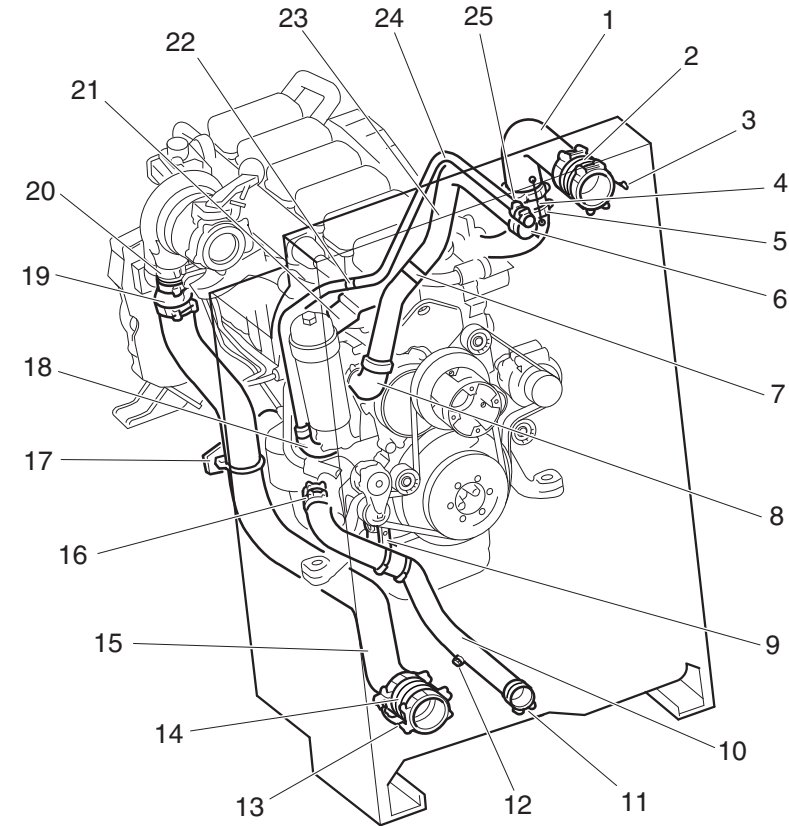

1.3 m² radiator for the DC13



Item	Part No.	Note	Qty	Designation
20	1 533 713		1	Charge air pipe
	1 439 822		1	V-clamp
	1 331 820	Ø 65.5 x 3 x 70.5	1	O-ring
21	1 746 149	DC13 with EGR	1	Bracket
	1 859 205	DC13 without EGR	1	Bracket
	812 516	M8x20	3	Flange screw
22	804 583	Ø 25 mm	1	Clamp
	812 503	M6x20	1	Flange screw
23	2 000 417		1	Coolant pipe
24	1 748 814		1	Coolant pipe
25	1 748 815	L = 100 mm	1	Hose
	816 131	Ø 30-45 mm	2	Hose clamp

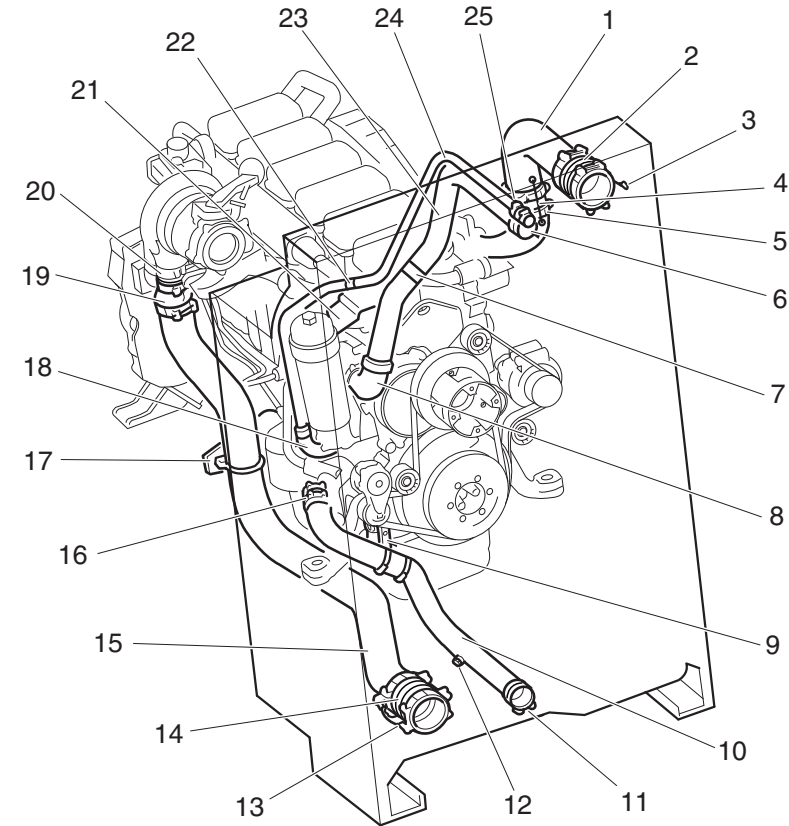

1.3 m² radiator for the DC13



1.5 m² radiator for the DC16

Item	Part No.	Note	Qty	Designation
1	2 329 707		1	Cooling package
2	1 914 882	L = 80 mm	1	Hose
	816 133	Ø 32-50 mm	2	Hose clamp
3	812 515	M8x16	2	Flange screw
4	1 766 511	L = 102 mm	1	Hose
	1 495 780	Ø 100-116 mm	2	Hose clamp
5	1 823 696		1	Charge air pipe
6	1 833 822		2	Safety cord
	1 833 825		4	Spacing sleeve
	812 515	M8x16	4	Flange screw
7	1 503 691	L = 140 mm	1	Hose
	1 495 780	Ø 100-116 mm	2	Hose clamp
8	2 003 697		1	Static line pipe
9	1 117 826	Ø 32 mm	1	Clamp
	812 534	M10x20	1	Flange screw
	815 133	M10	1	Flange nut
10	223 315	L = 100 mm	1	Hose
	816 135	Ø 50-72 mm	2	Hose clamp
11	2 003 698		1	Coolant pipe
12	278 474		1	Hose
	816 135	Ø 50-72 mm	2	Hose clamp
13	223 315	L = 100 mm	1	Hose
	816 135	Ø 50-72 mm	2	Hose clamp

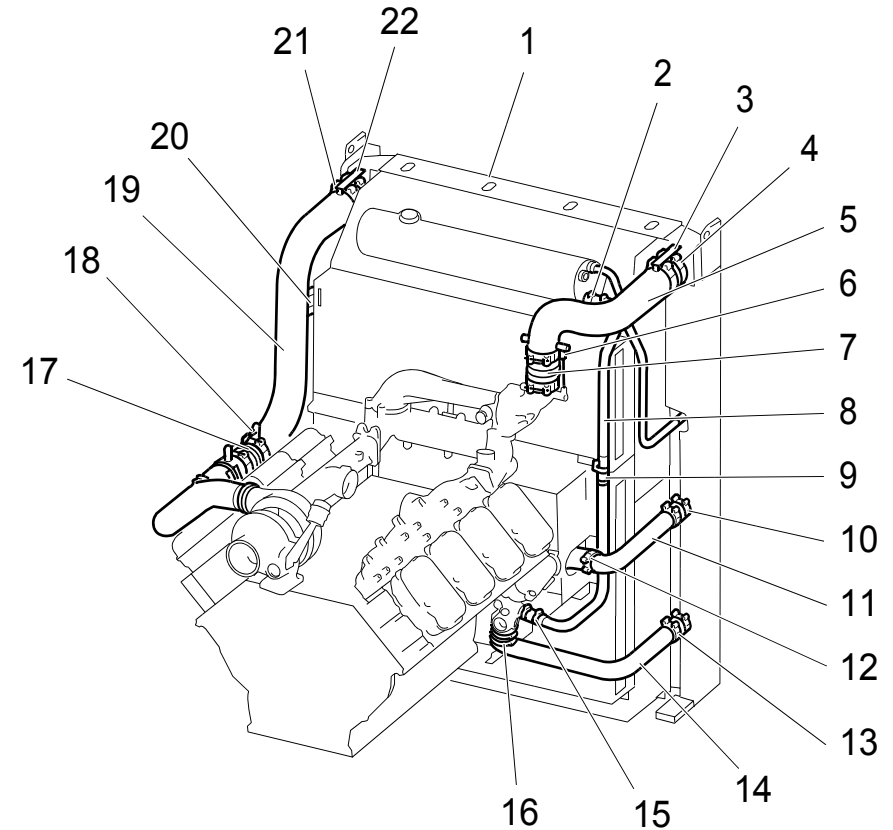

1.5 m² radiator for the DC16

351 244



Item	Part No.	Note	Qty	Designation
14	2 003 699	Not with SCR and EGR systems ¹	1	Coolant pipe
	2 229 463	Only with SCR and EGR systems	1	Coolant pipe
15	1 914 882	L = 80 mm	1	Hose
	816 133	Ø 32-50 mm	2	Hose clamp
16	223 315	L = 100 mm	1	Hose
	816 135	Ø 50-72 mm	2	Hose clamp
17	1 503 691	L = 140 mm	1	Hose
	1 495 780	Ø 100-116 mm	2	Hose clamp
18	1 883 817	Not with SCR and EGR systems	1	Safety cord
	1 833 825		2	Spacing sleeve
	812 515	M8x16	2	Flange screw
19	1 823 695		1	Charge air pipe
20	812 516	M8x20	2	Flange screw
	815 132	M8	2	Flange nut
21	1 766 511	L = 102 mm	1	Hose
	1 495 780	Ø 100-116 mm	2	Hose clamp
22	812 515	M8x16	2	Flange screw

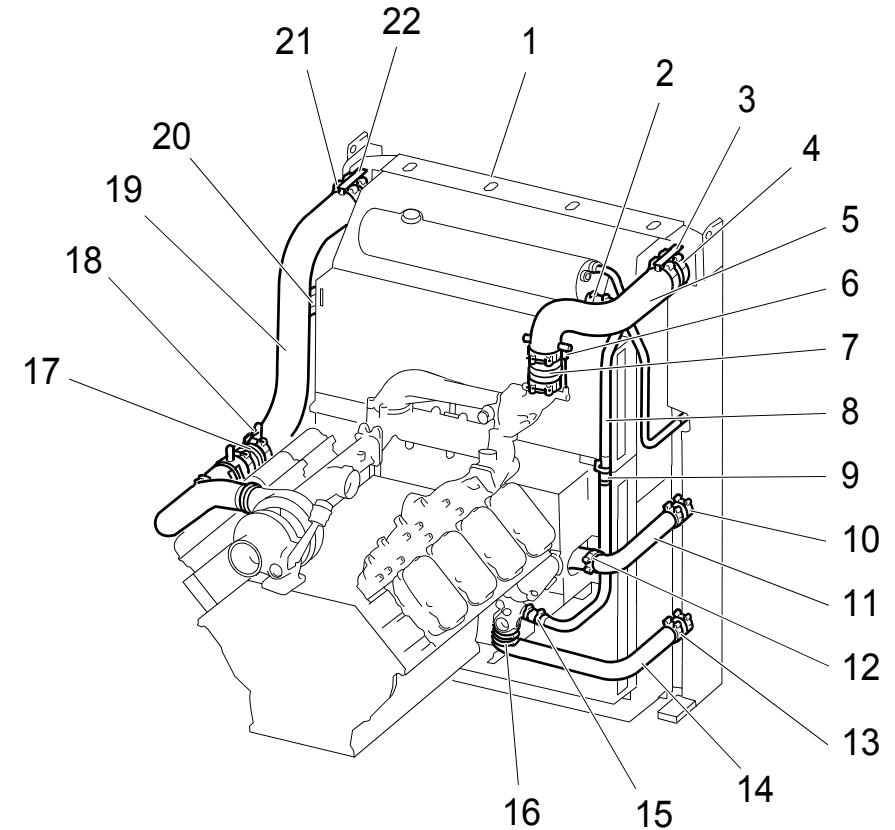

1. The coolant pipe is also supplied with engines with SCR and EGR systems, but has no application there.

1.5 m² radiator for the DC16

351 244