



# Industrial pumps

Stainless steel pumps for the general industries





## Reduce your Total Cost of Ownership by selecting the right pump

There are innumerable industrial processes in which pumps are used. And each process has its own specific characteristics and needs. But what they all have in common is that efficiency and cost reduction are always welcome. Packo helps to achieve this goal with a wide range of industrial pumps. Each detail of the pump has been conceived to reduce the 'Total Cost of Ownership'.

The extremely high energetic efficiency enables our pumps to achieve a lower energy consumption. This results in a lower energy bill. On top of that they are built with a solid construction which makes them reliable and gives them a long lifespan. Any maintenance is handled within the shortest possible downtime, as a result of the simple assembly which does not require fine-tuning.

Additionally, our pumps are constructed out of standardized parts, which only requires a small stock of spare parts for your entire pump pool. The seals and motors of the pumps have also been standardized. This means any spare parts required for replacement will always be available and will be competitively priced. Discover how our pumps can improve your processes in this brochure.

### We optimize your flow





# Industrial applications

Packo can offer a bespoke pump for nearly any industrial application, whatever the requirements. We differentiate ourselves with the lower energy consumption, reliability and easy maintenance of our pumps. A selection of different applications for which our pumps are used is shown on the following pages. Discover what the most important pump characteristics are and which pumps from our range are best suited for this purpose.

## 1. Washers, laboratory sterilizers, disinfection

- Standard & custom made solutions that fits into the machine
- Low liquid level, low NPSH at high temperature
- Low water and energy consumption

### Pump series:

NP60 .....	p. 12
ICP1 .....	p. 14
ICP+ .....	p. 20

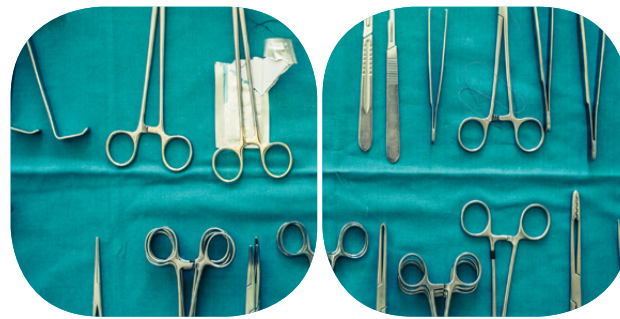

## 2. Autoclaves

- Pumping water up to 130 °C in closed loop
- High flow rates
- Low energy consumption
- Low NPSH available in installation

### Pump series:

ICP .....	p. 14-20
MCP .....	p. 22, p. 24



## 3. Animal feeding systems

- Liquid feeding systems for pigs, calves, etc.
- Wear resistant applications
- Robust and maintenance free

### Pump series:

MWP2 .....	p. 26
------------	-------

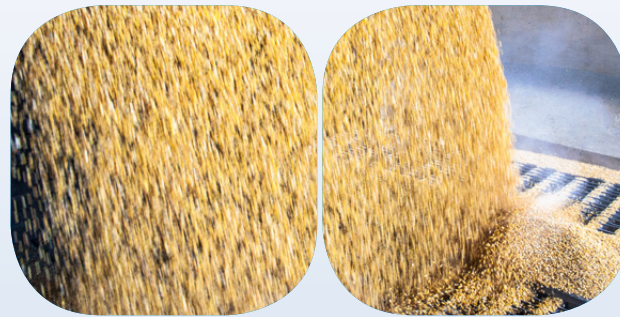

## 4. Air washing & cleaning

- Used in stables for evacuating unwanted pollutants
- Robust and maintenance free solutions
- Reliable mechanical seals, extended life time

### Pump series:

NP60 .....	p. 12
ICP .....	p. 14-20
MCP .....	p. 22, p. 24
IML .....	p. 46



## 5. Biogas production

- Coming from food waste, foodstuff from farms, etc.
- Circulation of liquid in digesters
- Corrosion resistant
- Capable to handle liquid containing solids and fibres
- Reliable mechanical seals, extended life time

### Pump series:

ICP .....	p. 14-20
MCP .....	p. 22, p. 24
IFF .....	p. 40
MFF .....	p. 42

## 6. Textile industry

- Bleaching, dyeing, washing (finishing tissue), etc.
- Tannery applications for production of cotton wadding, washing carpets, etc.
- Water, caustic soda, foam and fibre containing liquids
- Standard & custom made solutions that fit into the machine
- Solutions for handling liquid containing fibres

### Pump series:

NP60 .....	p. 12
ICP .....	p. 14-20
MCP .....	p. 22, p. 24
IFF .....	p. 40
MFF .....	p. 42



## 7. Surface treatment

- Powder coating, galvanizing, solvent and water paintings
- Degreasing, pickling, passivating, phosphating processes, etc.
- Available in accordance to ATEX
- 'Sealless' solutions

### Pump series:

NP60 .....	p. 12
ICP .....	p. 14-20
MCP .....	p. 22, p. 24
IFF .....	p. 40
MFF .....	p. 42
IML .....	p. 46



## 8. Vegetables, potatoes and shell fish

- Damage free pumping of vegetables, potatoes and shell fish.
- Blanching applications @ high temperatures up to 98 °C
- Low liquid level at high temperature, low NPSH
- Pumps with special vane for damage free product handling
- Robust pumps with lowest NPSH available on the market
- High efficiency, less energy costs

### Pump series:

ICP .....	p. 14-20
MCP .....	p. 22, p. 24
VPCP .....	p. 44





## 9. Hot frying oil

- Maintenance free solutions up to 200 °C
- Aggressive cleaning liquids at high temperatures
- Corrosion resistant
- Outboard installation



### Pump series:

IMO ..... p. 48

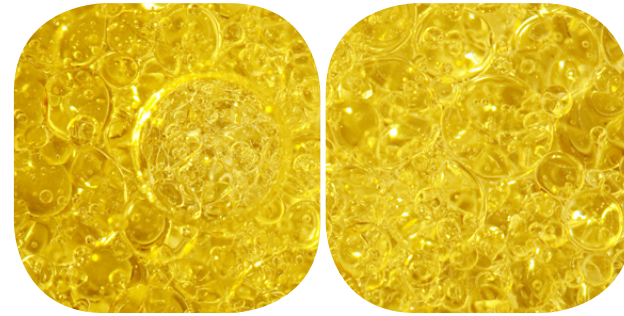

## 10. Waste water

- Industrial waste water coming from all sorts of production sites
- Solutions for Dissolved Air Flotation (DAF)
- Handling slightly contaminated liquids with fibres and solids
- Blockage free solutions with free flow pumps
- Maintenance free



### Pump series:

ICP ..... p. 14-20  
 MCP ..... p. 22, p. 24  
 IFF ..... p. 40  
 MFF ..... p. 42  
 IM ..... p. 46-52



## 11. Bio-ethanol

- Fermentation process of renewable feedstock
- Based on distillation and dehydration processes
- Rapeseed, sunflower, palm oil, used frying oil, etc.
- Typical pump applications mashing, cooking, yeast handling, ethanol, stillage, water, etc.
- ATEX environment



### Pump series:

ICP ..... p. 14-20  
 MCP ..... p. 22, p. 24



## 12. Bio-diesel

- Transformation of edible oils and fats into biodiesel
- Rapeseed, sunflower, palm oil, used frying oil, etc.
- Handling methyl esters, fatty acids, glycerin, sulphuric acid, methanol, biodiesel, etc.
- ATEX environment
- All kinds of seal configurations and O-ring materials available



### Pump series:

ICP ..... p. 14-20  
 MCP ..... p. 22, p. 24



## 13. Light chemical industry

- All kinds of liquids from utility applications such as nitric acids, caustic soda, etc.
- Corrosion resistant against aggressive media
- Robust construction with reliable mechanical seals, extended life time



### Pump series:

NP60 ..... p. 12  
 ICP ..... p. 14-20  
 MCP ..... p. 22, p. 24  
 IML ..... p. 46



## 14. Mining industry

- All kind of applications used in mining industry f.i. copper leaching in copper mine for copper extraction
- Handling high concentrated sulphuric acid 96-98% and low concentrated sulphuric acid with CuSO4 solution
- Solid pumps, robust seal chamber for extended seal life time
- Special seal configurations and O-ring materials depending on operating conditions



### Pump series:

ICP ..... p. 14-20  
 MCP ..... p. 22, p. 24  
 IM ..... p. 46-52

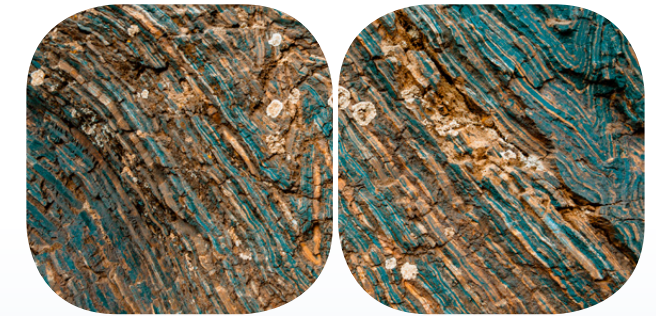

## 15. Other

There are many more applications which we have not mentioned yet, where our pumps are the right solution.

Think as well about:

- Handling glycol @ -40 °C, handling ice sludge
- White water, black liquor from paper industry
- Starch handling
- Pure water in semi-conductor industry
- Water circulation in slaughter line in poultry slaughterhouse
- Circulator pumps in the galvanic industry
- Circulator pumps in ice batteries
- Circulator pumps in clay baths
- Circulation of brine in cheese plants
- And many more



## Solid construction



Heavy constructed centrifugal pumps in stainless steel with investment cast impellers. These are more solid, less sensitive to crevice corrosion and obstruction compared to typical water pumps with spot welded impellers. Usage of open and channel impellers, large passage and non-clogging. Pump casings and back plates made of deep drawn or investment cast stainless steel are constructed much thicker compared to a traditional water pump resulting in extra seal stability in case of water hammer and giving an improved wear resistance against abrasive liquids.



Hydraulic high quality product with the highest pump efficiencies and lowest NPSH values. Lower energy bills thanks to the Packo pumps.

## Electropolished design (for wetted & non-wetted parts)

All pumps are electropolished. Compared to other techniques, this has the following advantages:

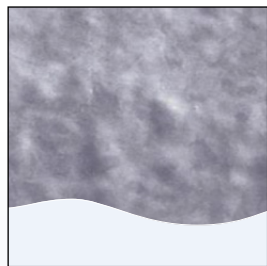

- Increased corrosion resistance
- Reduced internal material tensions, less 'tension' corrosion
- Increased resistance to adhesion of products
- Easier to clean, less bacteria traps

Electropolished

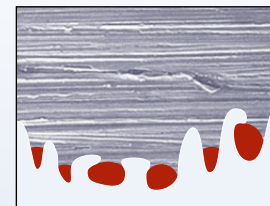
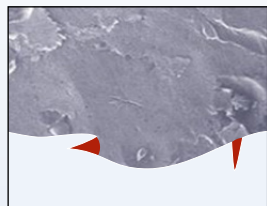

Glass bead blasted

Mechanical polishing 240 grit

\* Higher risk of bacteria traps with other pump brand.

# Centrifugal pumps designed for the industry

Packo pumps are the reliable partner for about all industrial applications. With their solid and easy construction, their high efficiency and low NPSH, they rank among the most reliable and maintenance friendly pumps for general industrial applications.

Discover some of the Packo pumps characteristics and find the perfect match for your production process.



Standardized mechanical seals to EN12756. Limited number of dimensions for the full Packo pump range.



Balanced O-ring seals are available for higher inlet pressures. Different seal configurations depending on liquid characteristics: single, quench, double pressureless or pressurized barrier



According to applicable standards and legislations, particularly within Europe, but also outside.



## Modular concept

The ICP, IFF, IRP and MSP series consist of the same components. Only the pump casing (and for some IFF pumps also the impeller) is different. This minimises the spare parts stock. Vertical cantilever pumps (ICP-IM) and pumps on pedestal can be supplied and some models are available in vertical In-Line (ICP-IL) construction.

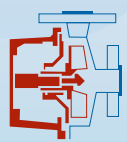

ICP

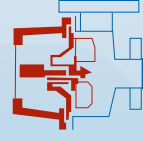

IFF



IRP

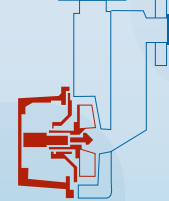

MSP

Before shipping all pumps are subjected to a thorough automated testing procedure. Performance and hydrostatic pressure tests, as well as a vibration test and control of the main dimensions are part of the standard test procedure. 100% final inspection!

ISO 9001:2015  
ISO 14001:2015



BQA\_QMS019\_C\_1994041



BQA\_EM5019\_C\_2015041



Standardized motor dimensions to IEC. Available in accordance with local motor laws.



# Product overview centrifugal pumps

	MEI	ATEX	1935/2004 EC	Connections	Electropolished	Pump casing
NP60	√	○	-	Industrial	√	Stainless steel pressed cold rolled plate
ICP1	√	○	-	Industrial	√	Stainless steel pressed cold rolled plate
ICP2	√	○	-	Industrial	√	Stainless steel pressed cold rolled plate
ICP+	√	○	√	Hygienic	√	Stainless steel pressed cold rolled plate
ICP3	√	○	√	Industrial or hygienic	√	Stainless steel pressed cold rolled plate
MCP2	√	○	√	Industrial	√	Stainless steel investment cast
MWP2	-	○	-	Industrial	√	Duplex investment cast
MCP3	√	○	√	Industrial	√	Stainless steel investment cast
IPP2	-	○	√	Industrial or hygienic	√	Stainless steel machined
NMS	-	○	√	Industrial	√	Stainless steel pressed and investment cast
IRP	-	○	-	Industrial	√	Stainless steel pressed cold rolled plate
IRP+	-	○	√	Hygienic	√	Stainless steel pressed cold rolled plate
MSP2	-	○	√	Industrial or hygienic	√	Stainless steel investment cast
IFF	-	○	√	Industrial or hygienic	√	Stainless steel pressed cold rolled plate
MFF	-	○	√	Industrial or hygienic	√	Stainless steel investment cast
SFP2	-	○	√	Hygienic	√	Stainless steel pressed cold rolled plate
SFP3	-	○	√	Hygienic	√	Stainless steel pressed cold rolled plate
VPCP	-	-	√	Industrial	√	Stainless steel welded
IML	-	-	√	Industrial or hygienic	√	Stainless steel pressed and investment cast
IMO	-	-	√	Industrial or hygienic	√	Stainless steel pressed and investment cast
IMXL	-	-	√	Industrial or hygienic	√	Stainless steel pressed and investment cast

	Impeller	Quench	Double seal	Special feature	Page
NP60	Open	○	-	Industrial low cost pump	10
ICP1	Open	-	-	Industrial process pump with limited options	12
ICP2	Open	○	○	Robust pressed industrial pump	14
ICP+	Open	○	○	Industrial pump with hygienic fittings	16
ICP3	Closed	○	○	Robust pressed industrial pump	18
MCP2	Open or semi-open	○	○	Cast industrial pump	20
MWP2	Open	○	○	Wear resistant applications	22
MCP3	Closed	○	○	Flow up to 1800 m³/h	24
IPP2	Open	○	○	Max. inlet pressure 40 bar	26
NMS	Open	○	○	Multistage pump	28
IRP	Open	○	○	Air handling pump for unloading applications	30
IRP+	Open	○	○	Air handling pump for CIP return & unloading	32
MSP2	Open	○	○	Self priming pump	34
IFF	Open, semi-open or vortex	○	○	Free flow with large passage for fibres and solids	36
MFF	Open or vortex	○	○	Free flow with large passage for fibres and solids	38
SFP2	Open	○	○	High shear pump	40
SFP3	Closed	○	○	High shear pump	40
VPCP	Schoep	-	-	Large free passage	42
IML	Open, closed or vortex	-	-	Cantilever pump, maintenance free	44
IMO	Open, closed or vortex	-	-	Cantilever pump, maintenance free	46
IMXL	Open, closed or vortex	-	-	Vertical sump pump with slide bearing up to 1.5 m	48

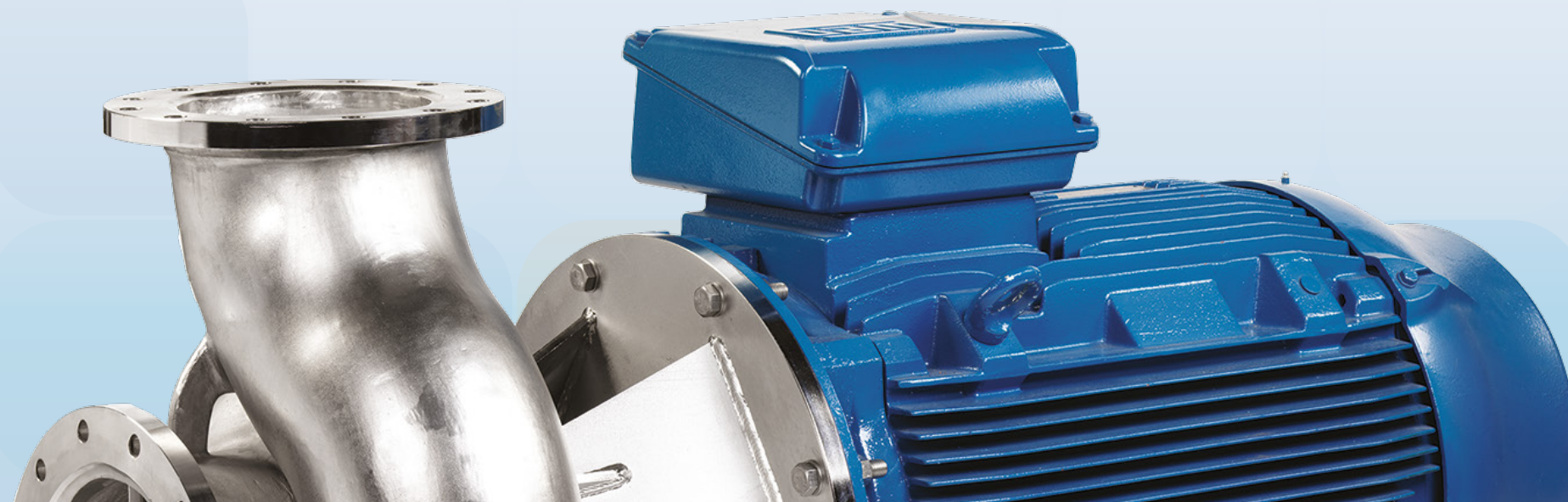

**Legend**

- √ = approved/standard
- = optional



# Pump series NP60

## Characteristics

The Packo stainless steel centrifugal pumps of the NP60 series are low cost industrial pumps. They have investment cast open impellers. This series achieves an overall high efficiency, leading to a lower energy consumption for your production process. Thanks to its modular concept it also guarantees an easy maintenance.

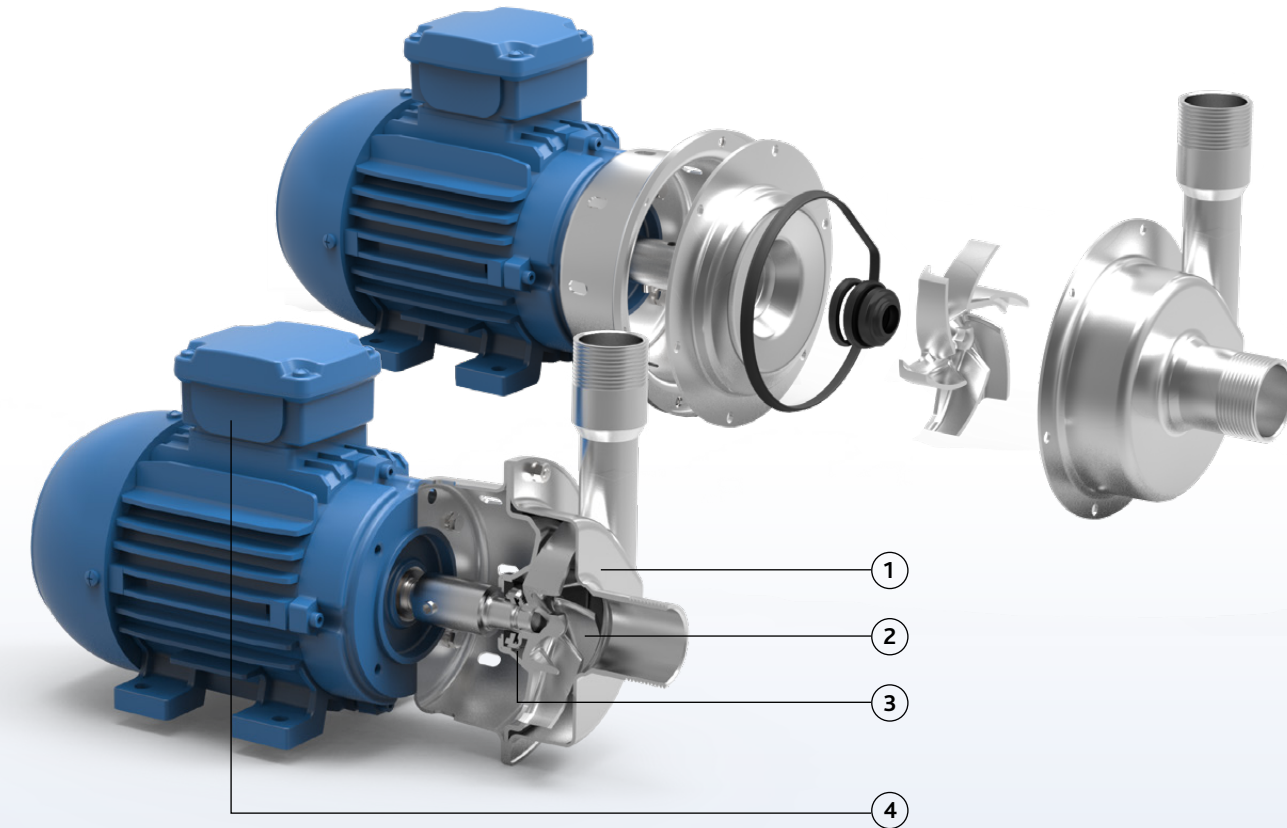

### NP60

- 1 Pressed stainless steel with minimum thickness of 2 mm
- 2 Investment cast open impellers
- 3 Large seal cavity to guarantee liquid circulation around the seal
- 4 Monobloc execution with std. IEC motors
- 5 One seal diameter for the entire range: Ø 18 mm





## Your benefits

- High pump efficiency resulting in lower energy consumption
- Low NPSH values: less risk on cavitation
- Electropolished: higher resistance against corrosion
- Easy construction and easy maintenance: less downtime
- Easy to install
- Solid impellers compared to low cost spot welded versions

## Application areas

The NP60 pumps are mainly used for pure as well as slightly contaminated liquids up to a maximum viscosity of 500 cP.

They are often used as process pump for the washing of textiles, for water treatment, but also for pumping solvents, alcohols and chemicals.

Pump series	NP60
<b>Performance</b>	
max. flow rate	40 m <sup>3</sup> /h
max. differential head	27 m
max. inlet pressure	3 bar
max. liquid viscosity	500 cP
max. temperature	95 °C
impeller type	open
max. free passage	15 mm
max. motor power	2.2 kW
max. speed	3000/3600 rpm
available frequency	50/60 Hz
<b>Technical specifications</b>	
materials wetted parts	stainless steel 316L or similar
mechanical seal configuration	single, quench
available O-ring materials	EPDM, FKM
connections	BSP fittings, flanges according to EN1092-1/02, smooth tubes
surface finish	industrial, internal welds not hand polished, electropolished
certificates & legislation	  

## Performance curves at 2900 rpm

### NP60

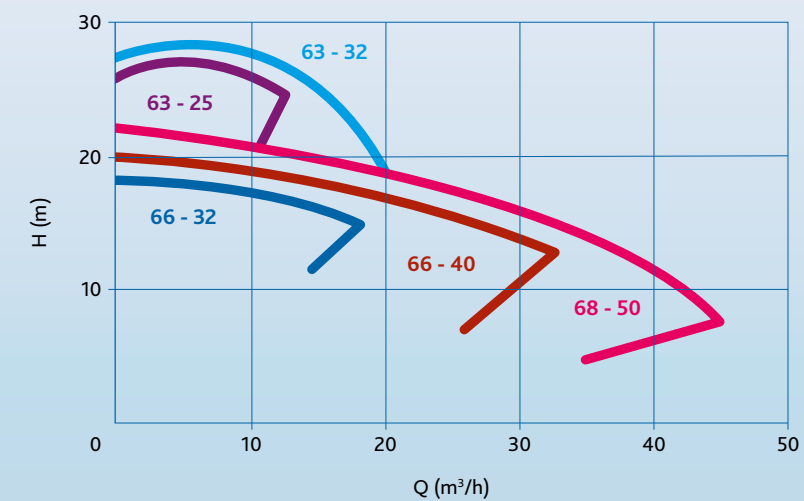



# Pump series ICP1



## Characteristics

The Packo stainless steel centrifugal pumps of the ICP1 series are the "best value for money" industrial pumps. They have investment cast open impellers. This series achieves an overall high efficiency, leading to a lower energy consumption for your production process. Thanks to its modular concept it also guarantees an easy maintenance.

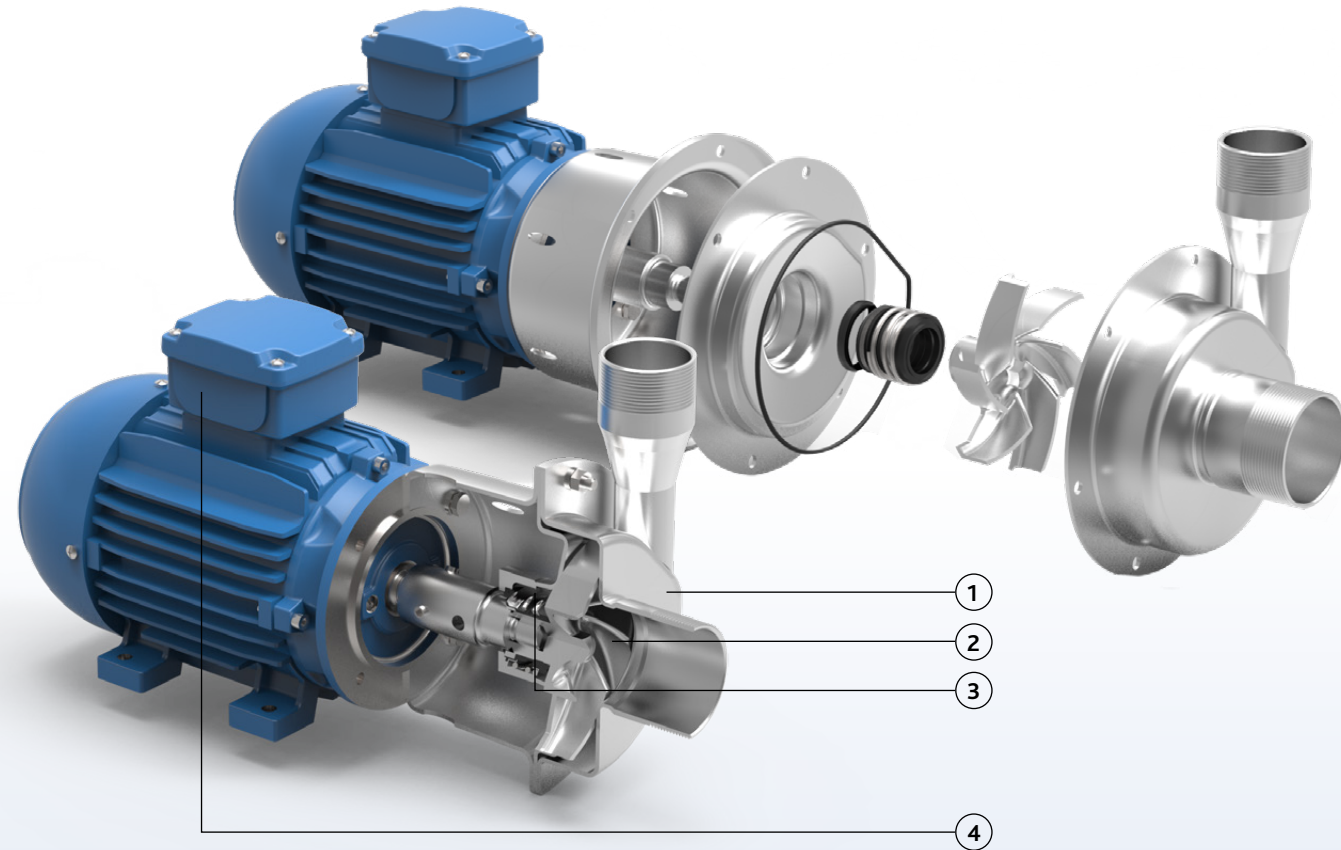

### ICP1

- 1 Pressed stainless steel with minimum thickness of 3 mm
- 2 Investment cast impellers
- 3 Large seal cavity to guarantee liquid circulation around the seal
- 4 Monobloc execution with std. IEC motors
- 5 Standardized mechanical seals to EN 12756  
bellow mechanical seals or balanced O-ring seals
- 6 One seal diameter for the entire range: Ø 33 mm





## Your benefits

- High pump efficiency resulting in lower energy consumption
- Low NPSH values: less risk on cavitation
- Electropolished: higher resistance against corrosion
- Easy construction and easy maintenance: less downtime
- Easy to install
- Solid impellers compared to low cost spot welded versions
- Standard components

## Application areas

The ICP1 pumps are mainly used for pure as well as for slightly contaminated liquids.

They are often used as a process pump in textile industry for washing textiles, for water treatment, but also for handling solvents, alcohols and chemicals.

Pump series	ICP1
<b>Performance</b>	
max. flow rate	55 m³/h
max. differential head	37 m
max. inlet pressure	6 bar
max. liquid viscosity	1000 cP
max. temperature	140 °C
impeller type	Open
max. free passage	18 mm
max. motor power	5.5 kW
max. speed	3000/3600 rpm
available frequency	50/60 Hz
<b>Technical specifications</b>	
materials wetted parts	stainless steel 316L or similar
mechanical seal configuration	single bellow, single balanced
available O-ring materials	EPDM, FKM, FEP, FFKM
connections	BSP fittings, flanges according to EN1092-1/02, smooth tubes
surface finish	industrial, internal welds not hand polished, electropolished
certificates & legislation	  

## Performance curves at 2900 rpm

### ICP1

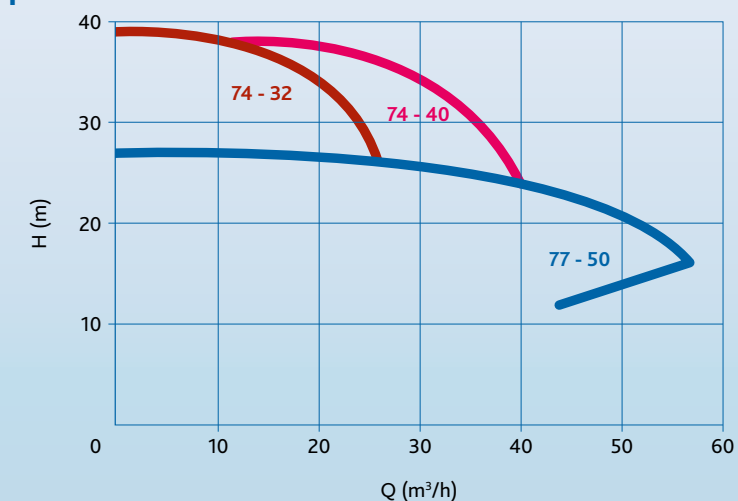



# Pump series ICP2



## Characteristics

These robust pumps have stainless steel 316L pump casings constructed in thick cold rolled plate and have open investment cast impellers in stainless steel 316L or duplex materials. Thanks to its solid construction and electropolished design these pumps are the reliable component for your production process.

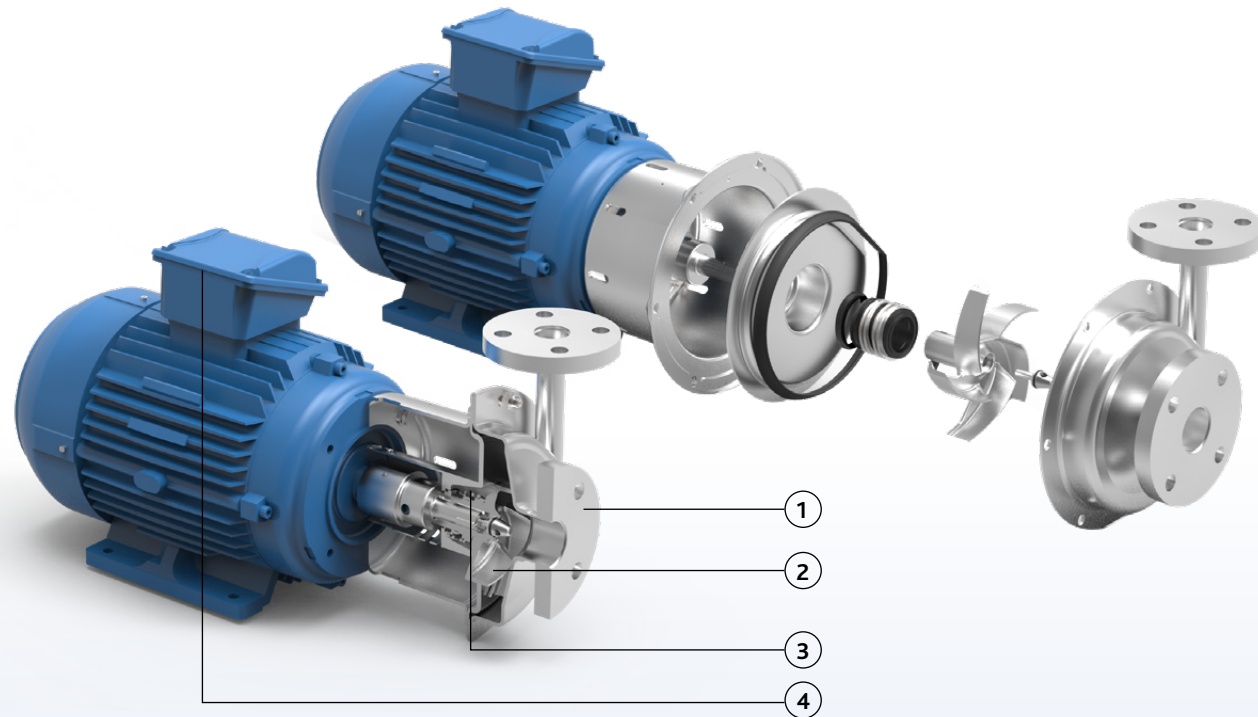

## ICP2

- 1 Pressed stainless steel, pump casing thickness up to 8 mm, back plate up to 20 mm
- 2 Investment cast impellers
- 3 Large seal cavity to guarantee liquid circulation around the seal
- 4 Monobloc execution with std. IEC motors
- 5 Standardized mechanical seals to EN 12756, all kind of configurations
- 6 One seal diameter: Ø 33 mm.  
Except for  
250 types: Ø 43 mm  
315 types: Ø 70 mm



Bellow seal

## Your benefits



- High pump efficiency resulting in lower energy consumption
- Low NPSH values: less risk on cavitation
- Electropolished: higher resistance against corrosion
- Easy & robust construction and easy maintenance: less downtime
- Easy to install
- Solid impellers compared to low cost spot welded versions
- Standardized seals guaranteeing worldwide easy availability and low spare parts prices
- Standard components

## Application areas

The Packo pumps of the series ICP2 are used in a wide range of industries and applications.

You can find them in just about all industries such as vegetable industry, breweries, water treatment and textile industry as well as in e.g. biogas, biodiesel and bioethanol applications.

Typical liquids: blanching water, mash, wort, process and contaminated water, biodiesel, bioethanol, alcohols, CIP, biogas, etc.

Pump series	ICP2
<b>Performance</b>	
max. flow rate	110 m <sup>3</sup> /h
max. differential head	220 m
max. inlet pressure	13 bar
max. liquid viscosity	1000 cP
max. temperature	140 °C
impeller type	open
max. free passage	22 mm
max. motor power	90 kW
max. speed	3000/3600 rpm
available frequency	50/60 Hz
<b>Technical specifications</b>	
materials wetted parts	stainless steel 316L or similar
mechanical seal configuration	single bellow, single balanced, quench, double, pressurized barrier
available O-ring materials	EPDM, FKM, FEP-FKM, FFKM, Silicone
connections	BSP fittings, flanges according to EN1092-1/01 & 02, ANSI flanges, smooth tubes
surface finish	industrial, internal welds not hand polished, electropolished
certificates & legislation	  

## Performance curves at 2900 rpm

### ICP2

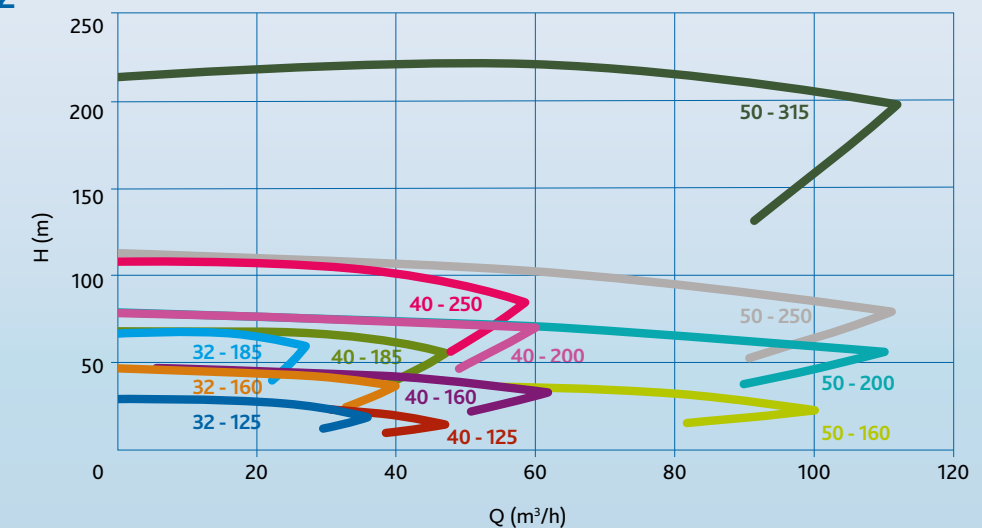



# Pump series ICP3



## Characteristics

These robust pumps have stainless steel 316L pump casings constructed in thick cold rolled plate and have closed investment cast impellers in duplex materials. Thanks to its solid construction and electropolished design these pumps are the reliable component for your production process.

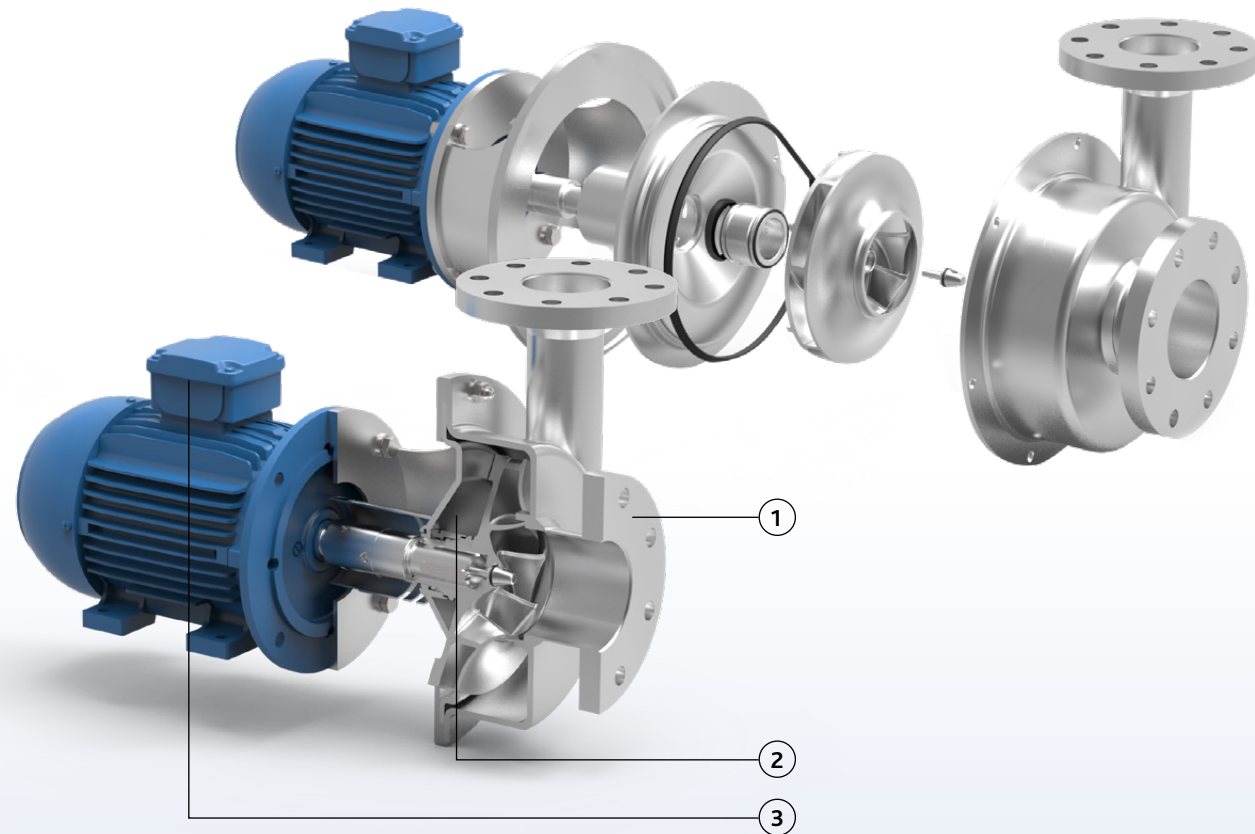

## ICP3

- 1 Pressed stainless steel, pump casing thickness up to 8 mm, back plate up to 30 mm
- 2 Large seal cavity to guarantee liquid circulation around the seal
- 3 Monobloc execution with std. IEC motors
- 4 Standardized mechanical seals to EN 12756  
FDA approved bellow mechanical seals or balanced O-ring seals
- 5 2 seal diameters for the entire range:
  - motor power > 22 kW 4p or 45 kW 2p: Ø 70 mm
  - motor power < 22 kW 4p or 45 kW 2p: Ø 43 mm



## Your benefits

- High pump efficiency resulting in lower energy consumption
- Low NPSH values: less risk on cavitation
- Electropolished: higher resistance against corrosion
- Easy & robust construction and easy maintenance: less downtime
- Easy to install
- Solid impellers compared to low cost spot welded versions
- 2 mechanical seal diameters for entire range
- Standard components

## Application areas

The Packo pumps of the series ICP3 are used in a wide range of industries and applications.

You can find them in just about all industries such as vegetable industry, breweries, water treatment and textile industry as well as in e.g. biogas, biodiesel and bioethanol applications.

Typical liquids: blanching water, mash, wort, process and contaminated water, biodiesel, bioethanol, alcohols, CIP, biogas, etc.

Pump series	ICP3
<b>Performance</b>	
max. flow rate	320 m <sup>3</sup> /h
max. differential head	120 m
max. discharge pressure	15 bar
max. liquid viscosity	1000 cP
max. temperature	140 °C
impeller type	closed with back vanes and balancing holes
max. free passage	21 mm
max. motor power	90 kW
max. speed	3000/3600 rpm
available frequency	50/60 Hz
<b>Technical specifications</b>	
materials wetted parts	stainless steel 316L or similar
mechanical seal configuration	single bellow, single balanced, quench, double, pressurized barrier
available O-ring materials	EPDM, FKM, FEP-FKM, FFKM, Silicone
connections	BSP fittings, flanges according to EN1092-1/01 & 02, ANSI flanges, smooth tubes
surface finish	industrial, internal welds not hand polished, electropolished
certificates & legislation	

## Performance curves at 2900 rpm

### ICP3

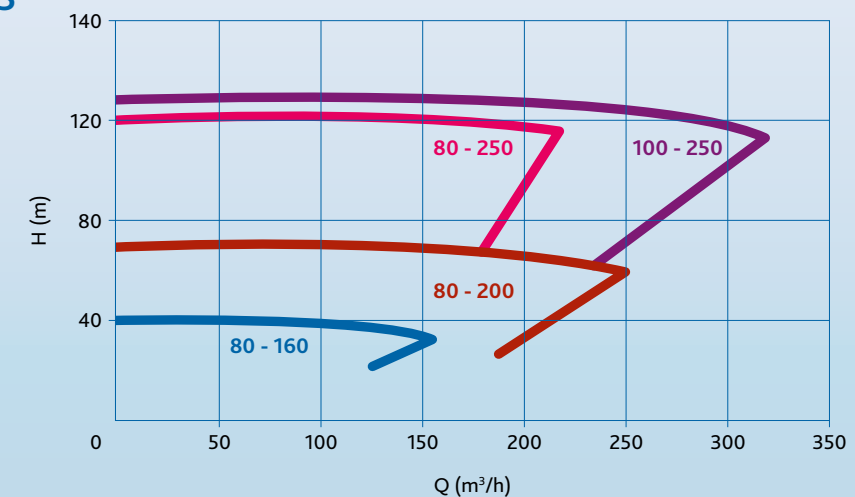



# Pump series ICP+



## Characteristics

These robust pumps have stainless steel 316L pump casings constructed in thick cold rolled plate and have open investment cast impellers in stainless steel 316L or duplex materials. Thanks to its solid construction and electropolished design these pumps are the reliable component for your production process.

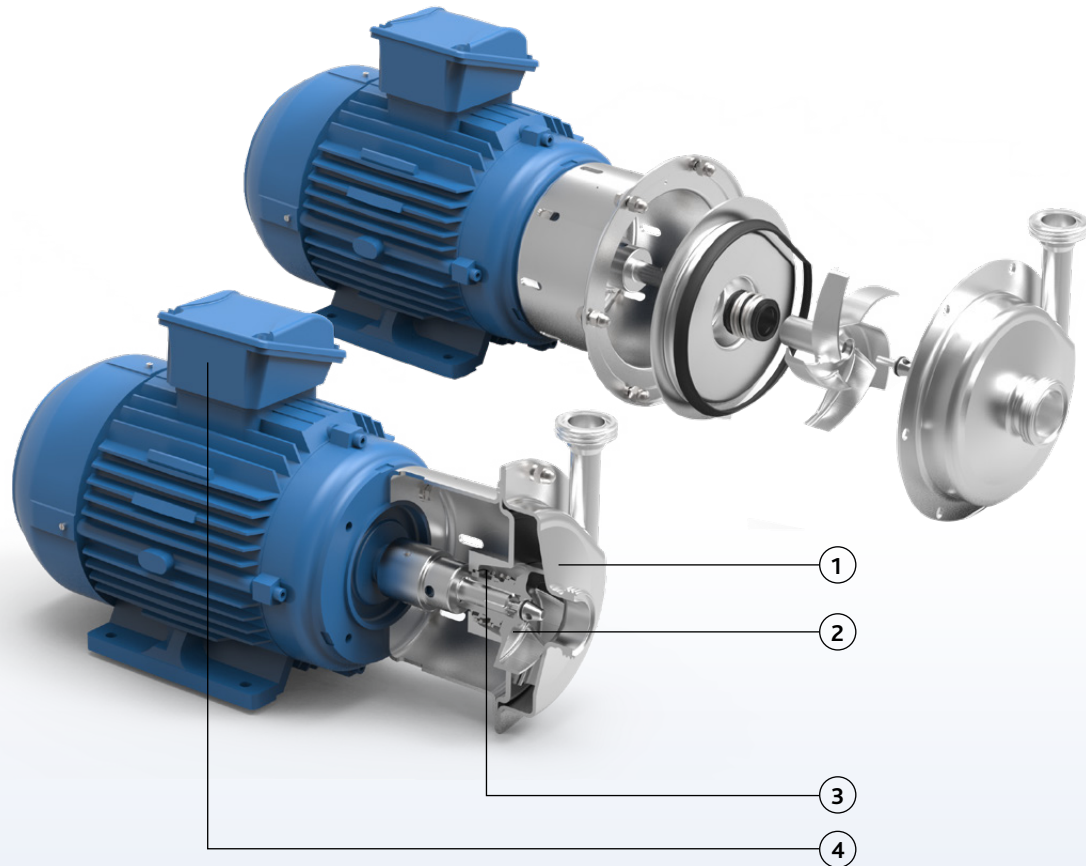

### ICP+

- 1 Pressed stainless steel, pump casing thickness up to 8 mm, back plate up to 20 mm
- 2 Investment cast impellers
- 3 Large seal cavity to guarantee liquid circulation around the seal
- 4 Monobloc execution with std. IEC motors
- 5 Standardized mechanical seals to EN 12756  
FDA approved bellow mechanical seals or balanced O-ring seals
- 6 One seal diameter: Ø 33 mm.  
Except for  
250 types: Ø 43 mm  
315 types: Ø 70 mm



## Your benefits

- High pump efficiency resulting in lower energy consumption
- Low NPSH values: less risk on cavitation
- Electropolished: higher resistance against corrosion
- Easy & robust construction and easy maintenance: less downtime
- Easy to install
- Solid impellers compared to low cost spot welded versions
- Standardized seals guaranteeing worldwide easy availability and low spare parts prices
- Standard components

## Application areas

The Packo pumps of the series ICP+ are used in a wide range of industries and applications. You can find them in just about all industries such as vegetable industry, breweries, dairies, distilleries, etc.

They are the ideal solution for filtration applications, pasteurisation, evaporating systems, yeast propagation and for CIP cleaning systems as well.

Typical applications include filtration of beer, wine and fruit juices as well as pumping yeast, whey and curd.

Pump series	ICP+
<b>Performance</b>	
max. flow rate	110 m <sup>3</sup> /h
max. differential head	220 m
max. inlet pressure	13 bar
max. liquid viscosity	1000 cP
max. temperature	140 °C
impeller type	open
max. free passage	22 mm
max. motor power	90 kW
max. speed	3000/3600 rpm
available frequency	50/60 Hz
<b>Technical specifications</b>	
materials wetted parts	stainless steel 316L or similar
mechanical seal configuration	single bellow, single balanced, quench, double, pressurized barrier
available O-ring materials	EPDM, FKM, FEP-FKM, FFKM, Silicone
connections	hygienic fittings
surface finish	industrial, internal welds not hand polished, electropolished
certificates & legislation	

## Performance curves at 2900 rpm

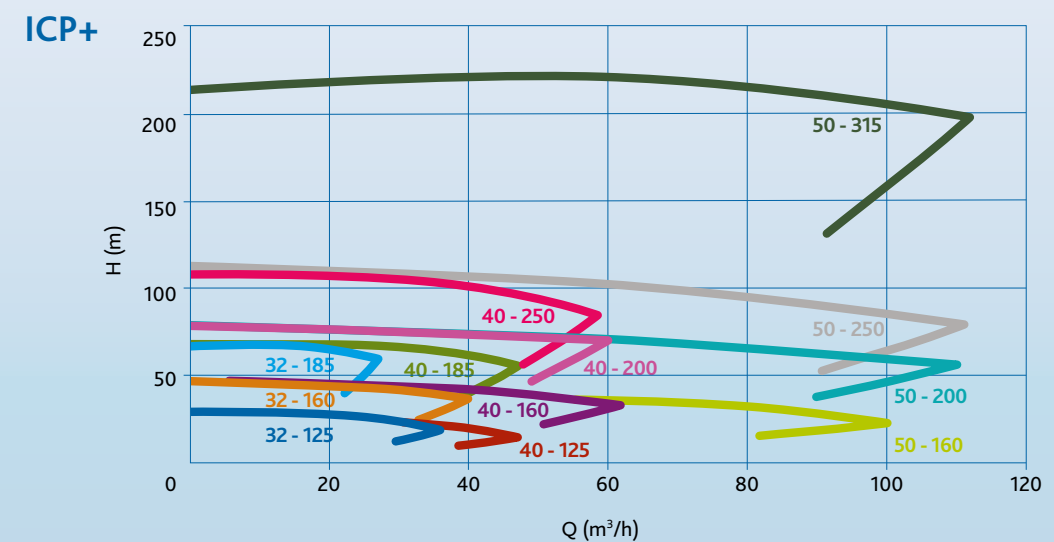



# Pump series MCP2



## Characteristics

These robust pumps have stainless steel 316L cast pump casings and open or semi-open investment cast impellers constructed in duplex materials. Thanks to its solid construction and electropolished design these pumps are the reliable component for your production process.

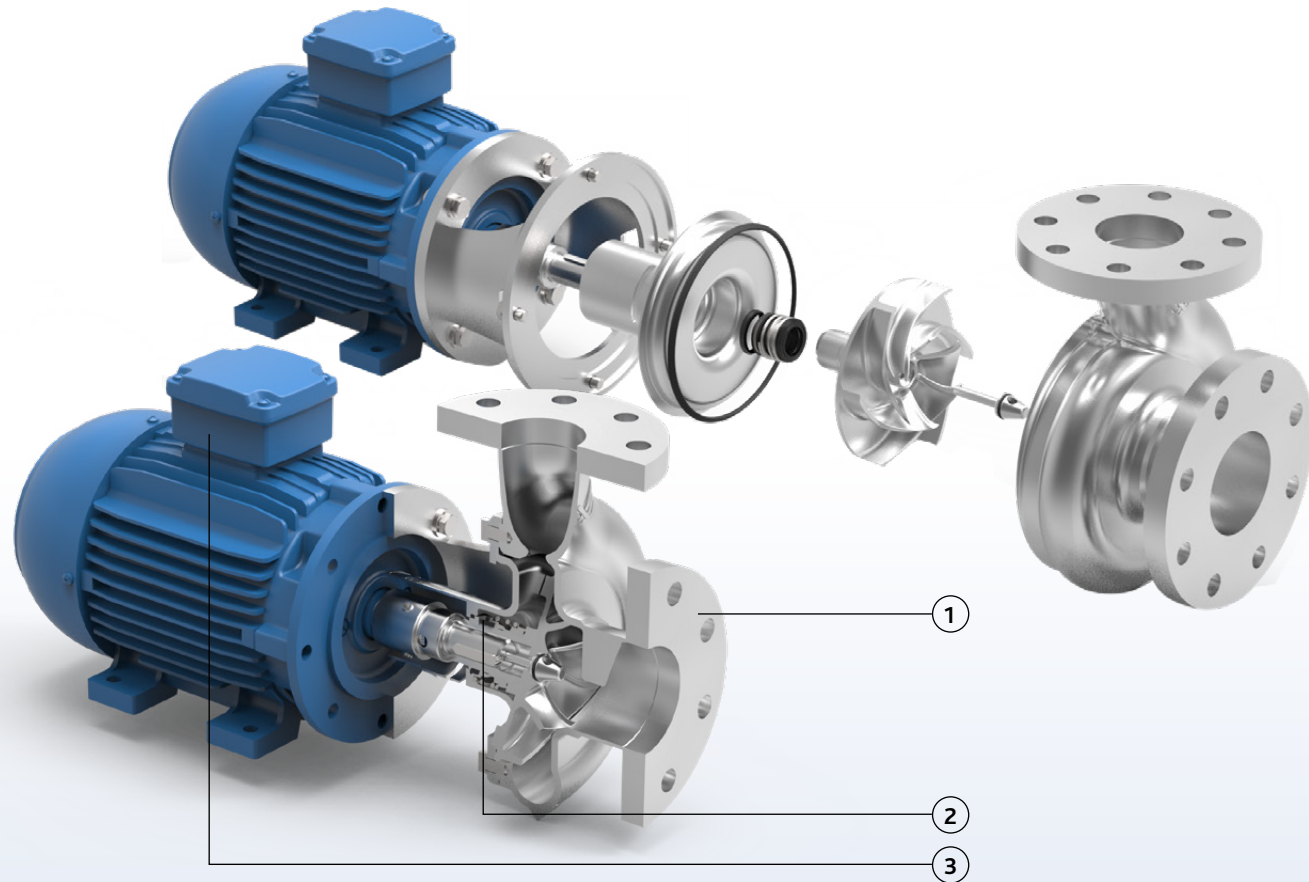

## MCP2

- 1 Solid design thanks to investment cast pump casings and impellers
- 2 Large seal cavity to guarantee liquid circulation around the seal
- 3 Monobloc execution with std. IEC motors
- 4 Standardized mechanical seals to EN 12756  
FDA approved bellow mechanical seals or balanced O-ring seals
- 5 One seal diameter for the entire range: Ø 33 mm



## Your benefits

- High pump efficiency resulting in lower energy consumption
- Low NPSH values: less risk on cavitation
- Electropolished: higher resistance against corrosion
- Easy and robust construction and easy maintenance: less downtime
- Easy to install
- Solid impellers compared to low cost spot welded versions
- 1 mechanical seal diameter for entire range
- Standard components

## Application areas

These robust process pumps are often used as process pump for contaminated water as well as for CIP cleaning systems, filtration of wine, mash, whey and blanching of vegetables.

Typical liquids: mash, wort, process and contaminated water, biodiesel, bioethanol, alcohols, CIP, biogas, etc.

Pump series	MCP2
<b>Performance</b>	
max. flow rate	120 m <sup>3</sup> /h
max. differential head	65 m
max. inlet pressure	10 bar
max. liquid viscosity	1000 cP
max. temperature	140 °C
impeller type	open or semi-open
max. free passage	25 mm
max. motor power	22 kW
max. speed	3000/3600 rpm
available frequency	50/60 Hz
<b>Technical specifications</b>	
materials wetted parts	stainless steel 316L or similar
mechanical seal configuration	single bellow, single balanced, quench, double, pressurized barrier
available O-ring materials	EPDM, FKM, FEP-FKM, FFKM, Silicone
connections	BSP fittings, flanges according to EN1092-1/01 & 02, ANSI flanges, smooth tubes
surface finish	industrial, internal welds not hand polished, electropolished
certificates & legislation	

## Performance curves

### MCP2

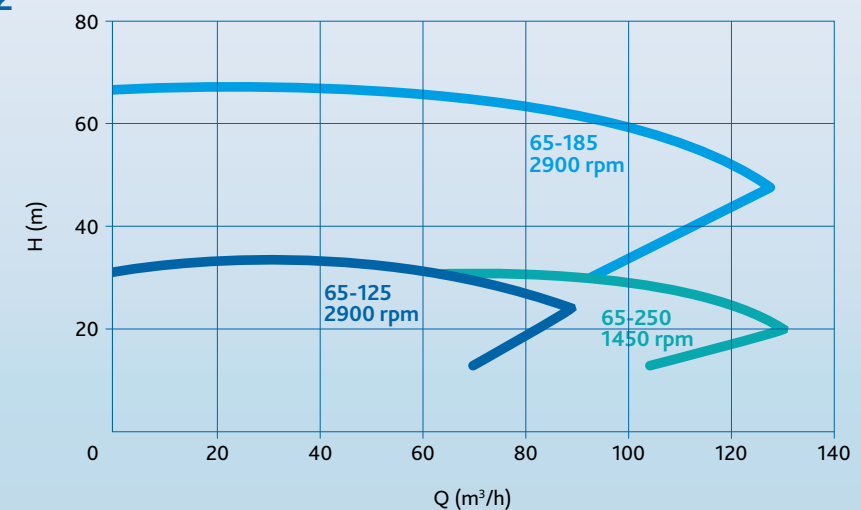

# Pump series MCP3



## Characteristics

These robust pumps have stainless steel 316L cast pump casings and closed or channel investment cast impellers constructed in duplex materials. Thanks to its solid construction and electropolished design these pumps are the reliable component for your production process.

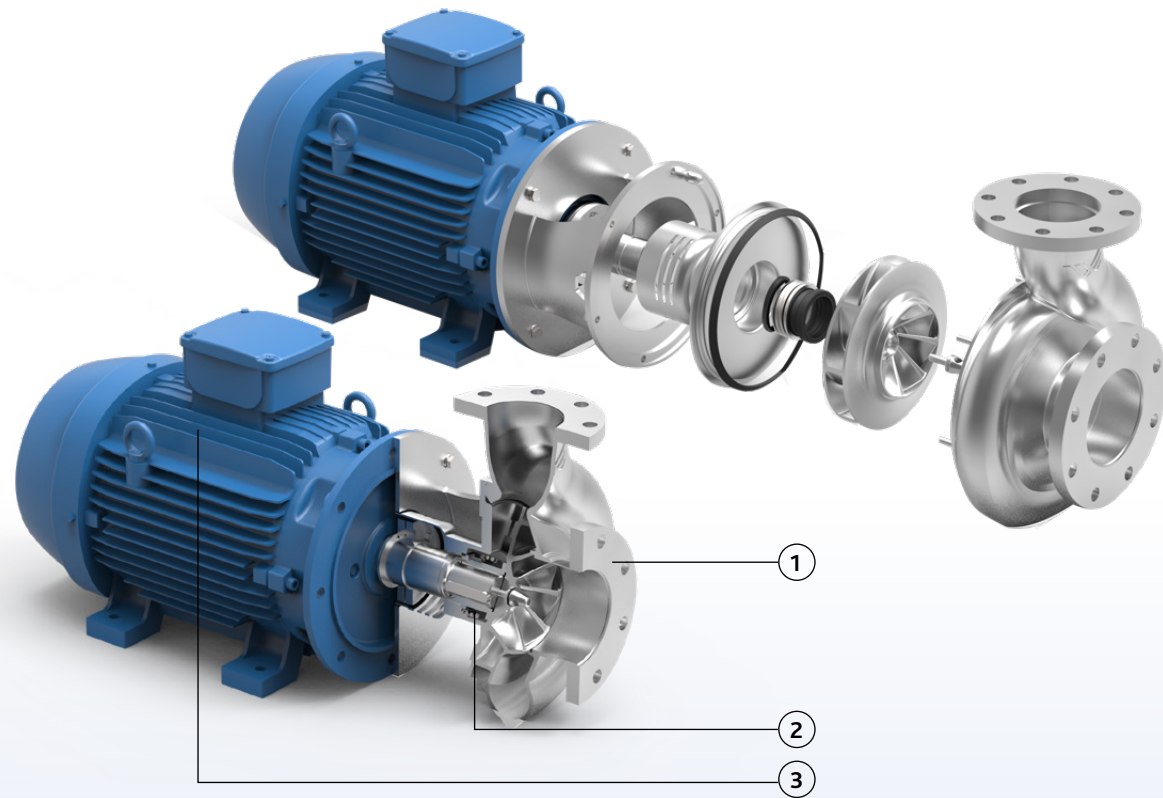

## MCP3

- 1 Solid design thanks to investment cast pump casings and impellers
- 2 Large seal cavity to guarantee liquid circulation around the seal
- 3 Monobloc execution with std. IEC motors
- 4 Standardized mechanical seals to EN 12756  
FDA approved bellow mechanical seals or balanced O-ring seals
- 5 Mechanical seal diameter depending on motor power: 43 - 70 - 100 mm



Bellow seal

## Your benefits

- High pump efficiency resulting in lower energy consumption
- Low NPSH values: less risk on cavitation
- Electropolished: higher resistance against corrosion
- Easy and robust construction and easy maintenance: less downtime
- Easy to install
- Very quiet operation
- Standard components

## Application areas

They are often used as process pump for contaminated water as well as for CIP cleaning systems, filtration of wine, mash, beer, whey and blanching of vegetables. Typical liquids: mash, wort, process and contaminated water, biodiesel, bioethanol, alcohols, CIP, biogas, etc.

Pump series	MCP3
<b>Performance</b>	
max. flow rate	1800 m <sup>3</sup> /h
max. differential head	75 m
max. discharge pressure	12 bar
max. liquid viscosity	500 cP
max. temperature	140 °C
impeller type	closed (with back vanes and balancing holes) – optional: channel impellers
max. free passage	closed impellers: 27 mm - channel impellers: 41 mm
max. motor power	250 kW
max. speed	3000/3600 rpm
available frequency	50/60 Hz
<b>Technical specifications</b>	
materials wetted parts	stainless steel 316L or similar
mechanical seal configuration	single bellow, single balanced, quench, double, pressurized barrier
available O-ring materials	EPDM, FKM, FEP-FKM, FFKM
connections	flanges according to EN1092-1/01 & 02, ANSI flanges
surface finish	industrial, internal welds not hand polished, electropolished
certificates & legislation	

## Performance curves

### MCP3

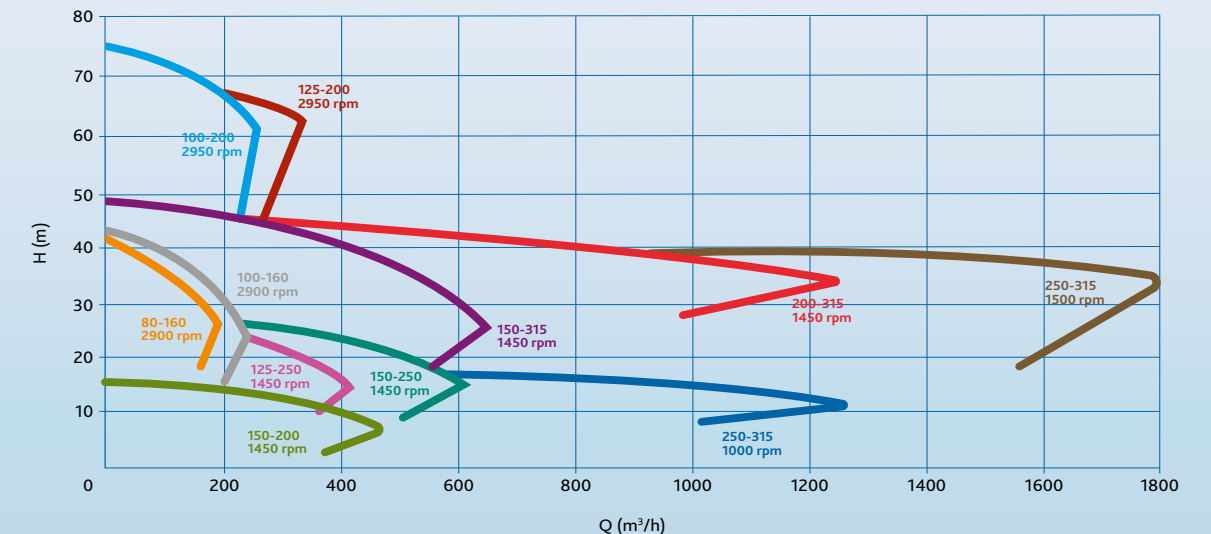



# Pump series MWP2



## Characteristics

These robust pumps are made of thick walled cast duplex stainless steel materials and have open impellers. Thanks to its solid construction and electropolished design these pumps are the reliable component for your production process. The Packo pumps of the MWP2 series are used in all kinds of industries for the transfer of erosive / abrasive liquids.

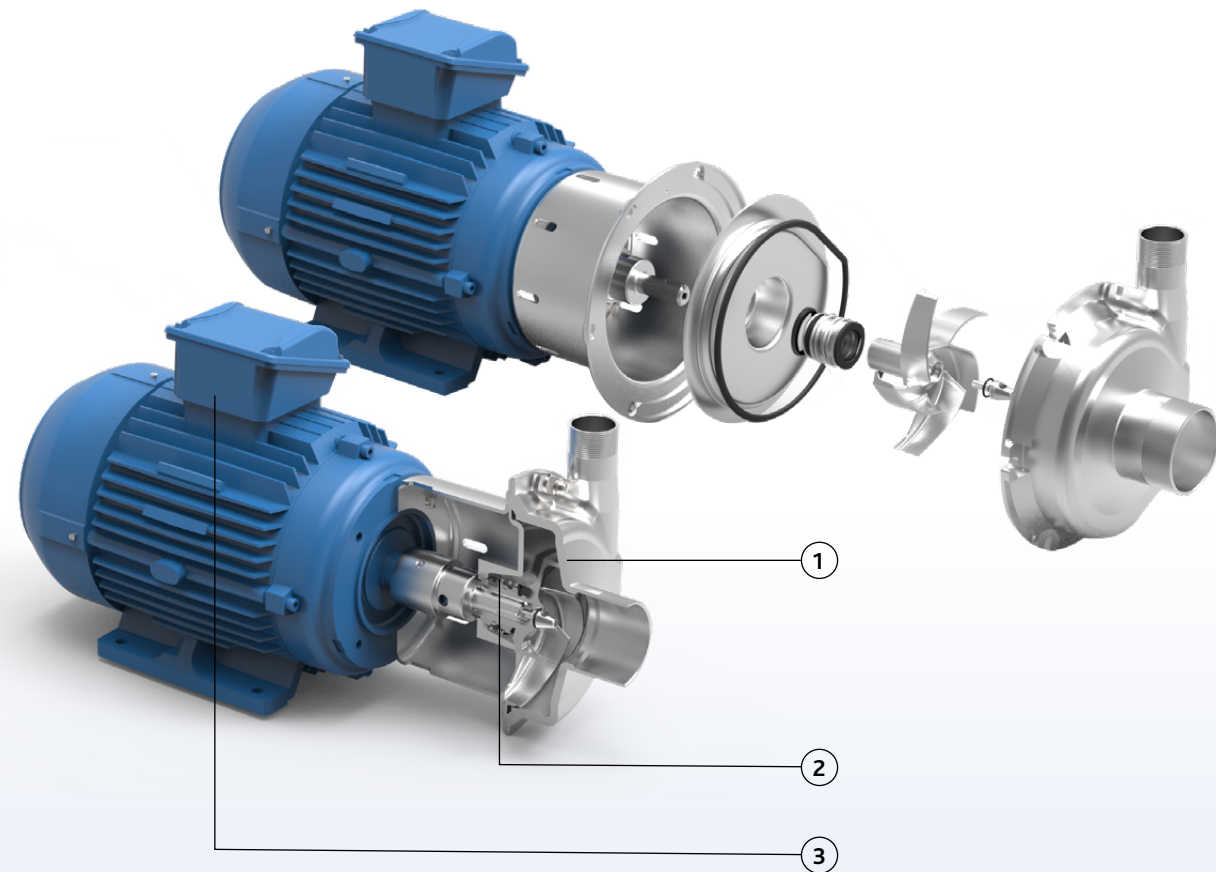

## MWP2

- 1 Solid investment cast duplex pump casing
- 2 Large seal cavity to guarantee liquid circulation around the seal
- 3 Monobloc execution with std. IEC motors
- 4 Standardized mechanical seals to EN 12756 bellow mechanical seals
- 5 One seal diameter for the entire range: Ø 33 mm



## Your benefits

- Wear resistant duplex pump casing ideal for handling abrasive liquids.
- Low NPSH values: less risk on cavitation
- Electropolished: higher resistance against corrosion
- Easy and robust construction and easy maintenance: less downtime
- Easy to install
- Solid impellers
- 1 mechanical seal diameter for entire range

## Application areas

These robust process pumps are often used as process pump for circulation of liquid feeding for animals, washing installations in potato and vegetable industry, diatomaceous earth (kieselgur) for filtration purposes, etc.

Pump series	MWP2
<b>Performance</b>	
max. flow rate	50 m <sup>3</sup> /h
max. differential head	60 m
max. inlet pressure	12 bar
max. liquid viscosity	1000 cP
max. temperature	140 °C
impeller type	open
max. free passage	22 mm
max. motor power	11 kW
max. speed	3000/3600 rpm
available frequency	50/60 Hz
<b>Technical specifications</b>	
materials wetted parts	duplex pump casings
mechanical seal configuration	single bellow, quench, double
available O-ring materials	EPDM, FKM, Silicone
connections	BSP fittings, flanges according to EN1092-1/01 & 02, ANSI flanges, smooth tubes
surface finish	industrial, internal welds not hand polished, electropolished
certificates & legislation	 EAC

## Performance curves at 2900 rpm

### MWP2

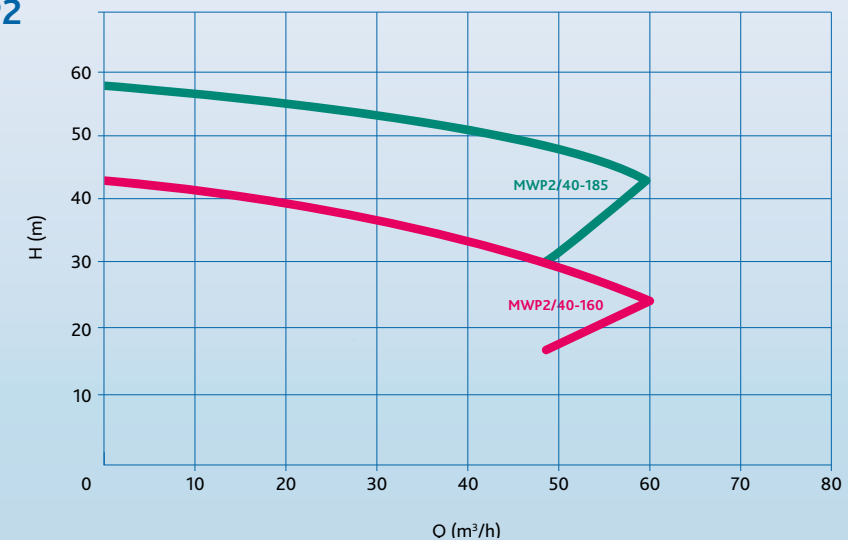

# Pump series IPP2



## Characteristics

The Packo stainless steel pumps of the IPP2 series are pumps made of solid, machined stainless steel 316L and are extremely suitable for high system pressure applications up to 40 bar.

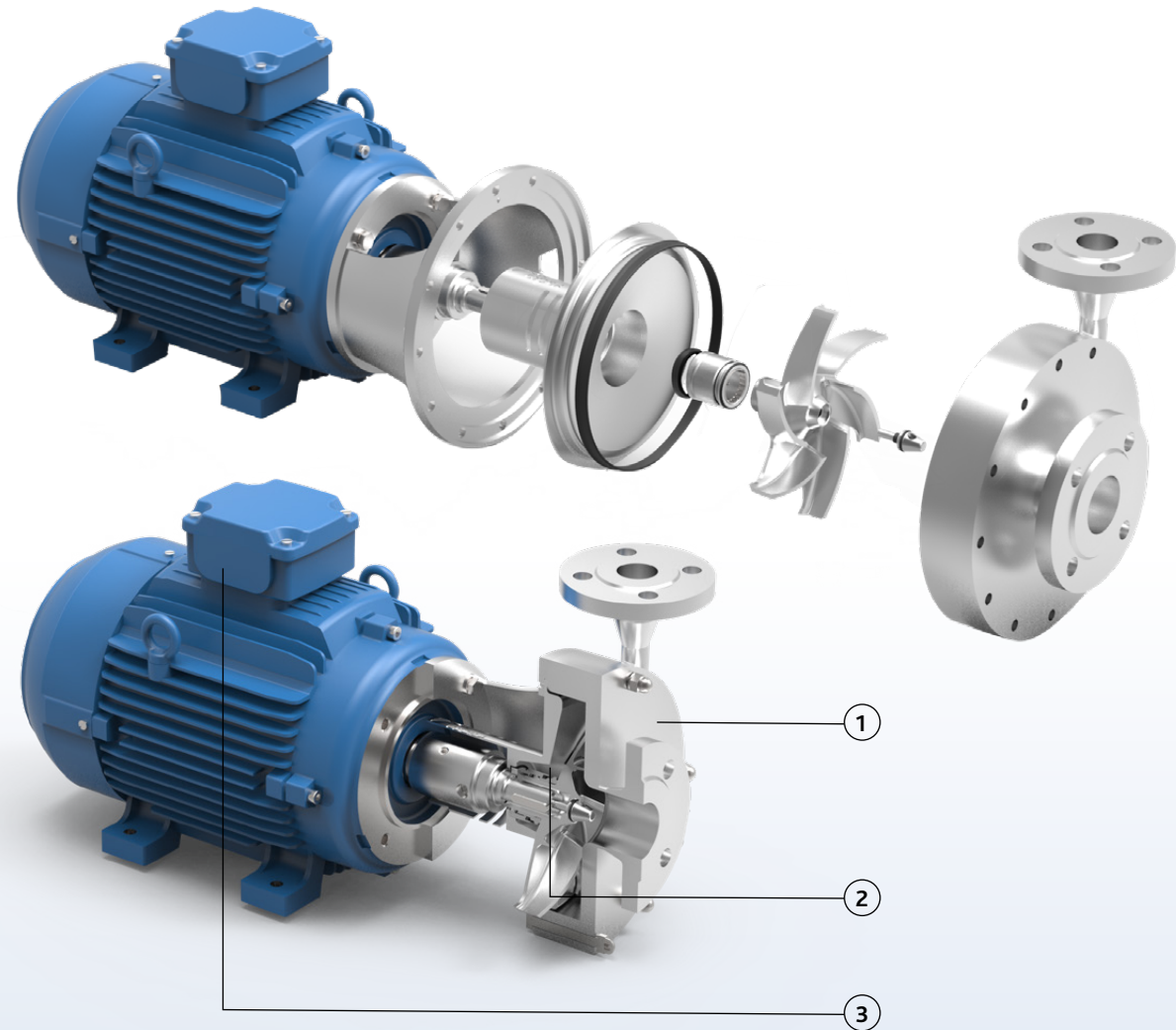

### IPP2

- 1 Solid design made of fully machined stainless steel
- 2 Large seal cavity to guarantee liquid circulation around the seal
- 3 Monobloc execution with std. IEC motors
- 4 Standardized mechanical seals to EN 12756  
FDA approved balanced O-ring seals
- 5 One seal diameter: Ø 33 mm.  
Except for 40-250:  
Ø 43 mm



## Your benefits

- Suitable for system pressure applications up to 40 bar
- High pump efficiency resulting in lower energy consumption
- Low NPSH values: less risk on cavitation
- Electropolished: higher resistance against corrosion
- Easy and robust construction and easy maintenance: less downtime
- Standard components
- Easy to install
- 2 mechanical seal diameters for the entire range

## Application areas

The Packo high pressure pumps of the IPP2 series are used primarily in reverse osmosis (RO) applications for the filtration of, for example, contaminated CIP-water, whey, etc.

They are also used as a booster pump in a variety of skids.

You will find them in just about all industries including the dairy industry, breweries, beverage industry as well as in water treatment industry.

Pump series	IPP2
<b>Performance</b>	
max. flow rate	110 m <sup>3</sup> /h
max. differential head	110 m
max. inlet pressure	40 bar
max. liquid viscosity	1000 cP
max. temperature	140 °C
impeller type	open
max. free passage	20 mm
max. motor power	45 kW
max. speed	3000 / 3600 rpm
available frequency	50 / 60 Hz
<b>Technical specifications</b>	
materials wetted parts	stainless steel 316L or similar
mechanical seal configuration	single balanced, quench, double
available O-ring materials	EPDM, FKM, FEP-FKM, FFKM, Silicone
connections	flanges according to EN1092-1/11 PN40, Tri-Clamp fittings, etc.
surface finish	industrial, internal welds not hand polished, electropolished
certificates & legislation	

## Performance curves at 2900 rpm

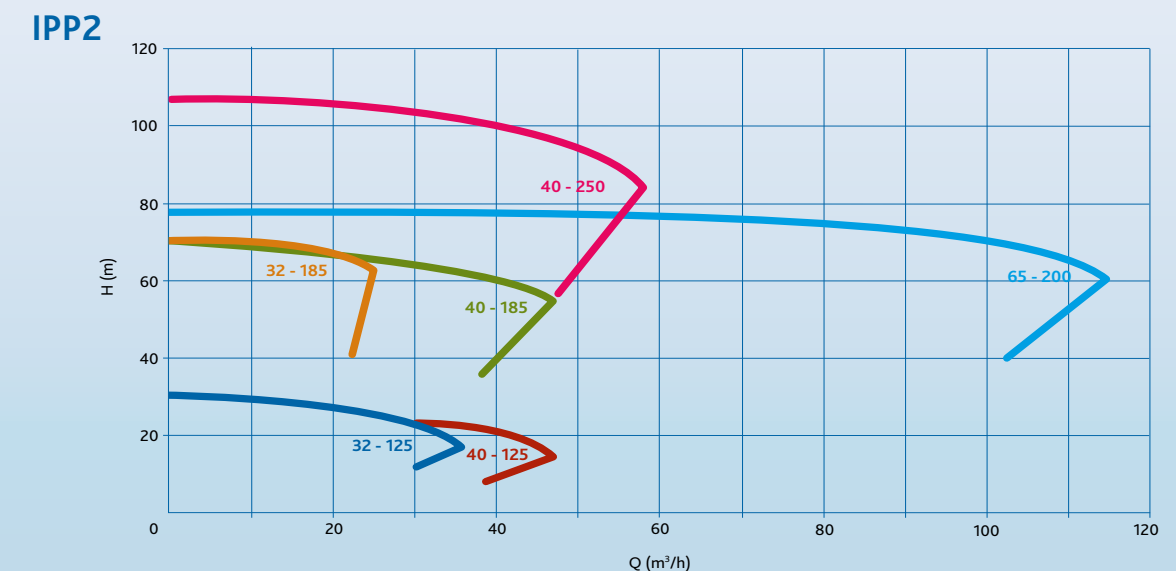



# Pump series IPP3



## Characteristics

The Packo stainless steel pumps of the IPP3 series are pumps made of solid, machined stainless steel 316L and are extremely suitable for high system pressure applications up to 40 bar.

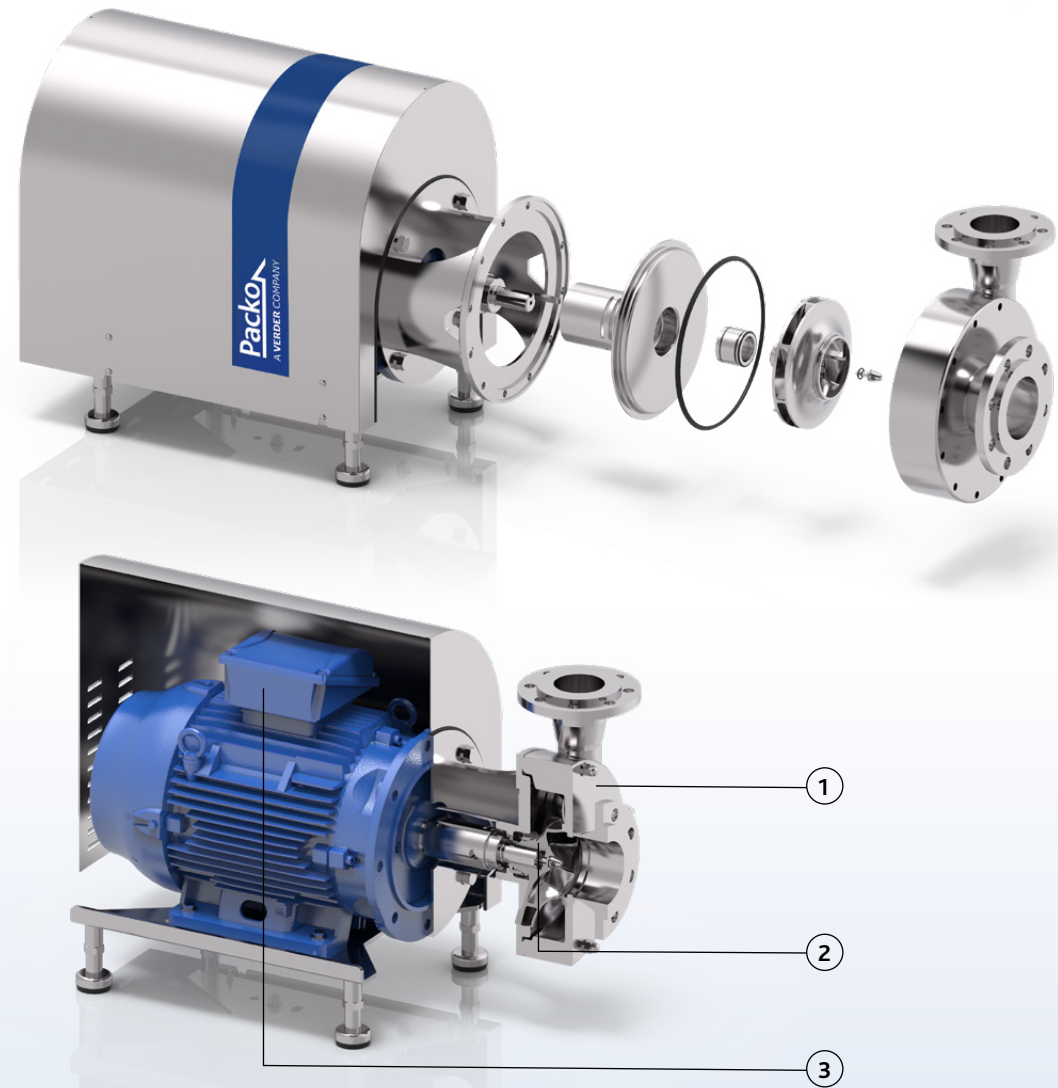

### IPP3

- 1 Solid design made of fully machined stainless steel
- 2 Large seal cavity to guarantee liquid circulation around the seal
- 3 Monobloc execution with std. IEC motors
- 4 Standardized mechanical seals to EN 12756  
FDA approved balanced O-ring seals
- 5 Seal diameter: Ø 43 mm



## Your benefits

- Suitable for system pressure applications up to 40 bar
- High pump efficiency resulting in lower energy consumption
- Low NPSH values: less risk on cavitation
- Electropolished: higher resistance against corrosion
- Easy and robust construction and easy maintenance: less downtime
- Standard components
- Easy to install
- 1 mechanical seal diameter



## Application areas

The Packo high pressure pumps of the IPP3 series are used primarily in reverse osmosis (RO) applications for the filtration of, for example, contaminated CIP-water, whey, etc. They are also used as a booster pump in a variety of skids.

You will find them in just about all industries including the dairy industry, breweries, beverage industry as well as in water treatment industry.

### Pump series

### IPP3

Performance	IPP3
max. flow rate	350 m <sup>3</sup> /h
max. differential head	70 m
max. inlet pressure	40 bar
max. liquid viscosity	1000 cP
max. temperature	140 °C
impeller type	closed
max. free passage	17 mm
max. motor power	45 kW
max. speed	3000 / 3600 rpm
available frequency	50 / 60 Hz
Technical specifications	
materials wetted parts	stainless steel 316L or similar
mechanical seal configuration	single balanced, quench, double
available O-ring materials	EPDM, FKM, FEP-FKM, FFKM, Silicone
connections	flanges according to EN1092-1/11 PN40, Tri-Clamp fittings, etc.
surface finish	industrial, internal welds not hand polished, electropolished
certificates & legislation	  

## Performance curves at 2900 rpm

### IPP3

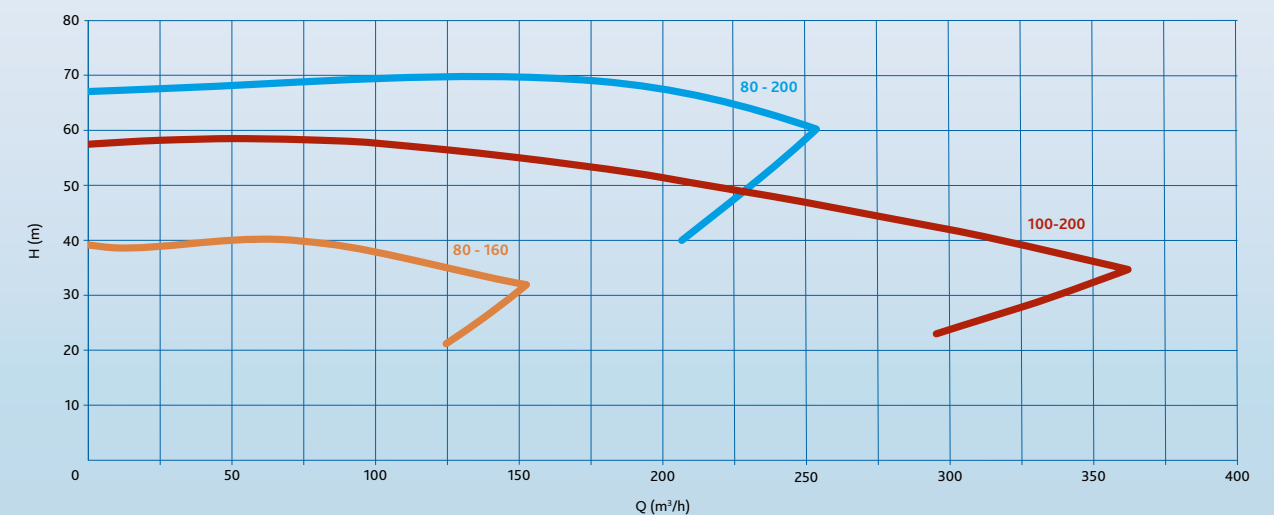

# Pump series NMS



## Characteristics

The Packo multistage pumps from the NMS series are equipped with open investment cast impellers and pump casings. They are the right match for operations at moderate flows and high pressures.

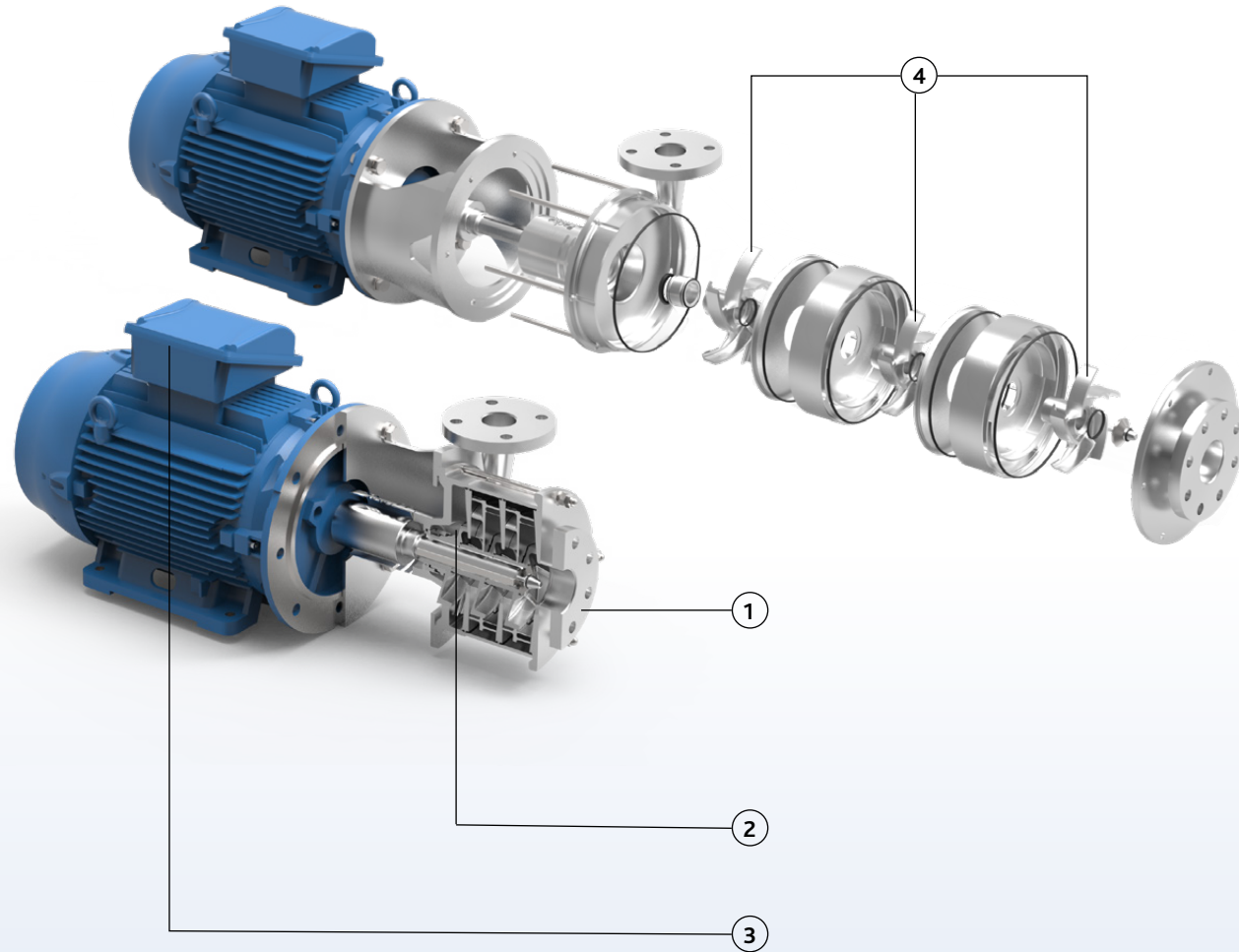

## NMS

- 1 Solid design thanks to investment cast pump casings and impellers
- 2 Large seal cavity to guarantee liquid circulation around the seal
- 3 Monobloc execution with std. IEC motors
- 4 Open impellers: no axial forces on motor bearings
- 5 Standardized mechanical seals to EN 12756  
FDA approved bellow mechanical seals or balanced O-ring seals







## Your benefits

- Ideal for operation at moderate flow rate and high pressures
- High pump efficiency resulting in lower energy consumption
- Low NPSH values: less risk on cavitation
- Electropolished: higher resistance against corrosion
- Easy & robust construction and easy maintenance: less downtime
- Standard components
- Easy to install
- Open impellers: longer bearing life

## Application areas

For use in food, brew, beverage, pharmaceutical and chemical industries, as transfer and mixing pump for liquid food products, drinks, medicines, lotions, etc.

Typical applications: process pump for plate heat exchangers, pasteurizer systems, filters, filling machines, mixers, deaerators, carbonators and high pressure cleaning systems.

Pump series	NMS
<b>Performance</b>	
max. flow rate	50 m <sup>3</sup> /h
max. differential head	215 m
max. inlet pressure	10 bar
max. liquid viscosity	250 cP
max. temperature	140 °C
impeller type	open
max. free passage	14 mm
max. motor power	45 kW
max. speed	3000/3600 rpm
available frequency	50/60 Hz
<b>Technical specifications</b>	
materials wetted parts	stainless steel 316L or similar
mechanical seal configuration	single bellow, single balanced, quench, double
available O-ring materials	EPDM, FKM
connections	flanges acc. to EN1092-1/01, Tri-Clamp fittings, etc.
surface finish	industrial, internal welds not hand polished, electropolished
certificates & legislation	   

## Performance curves at 2900 rpm

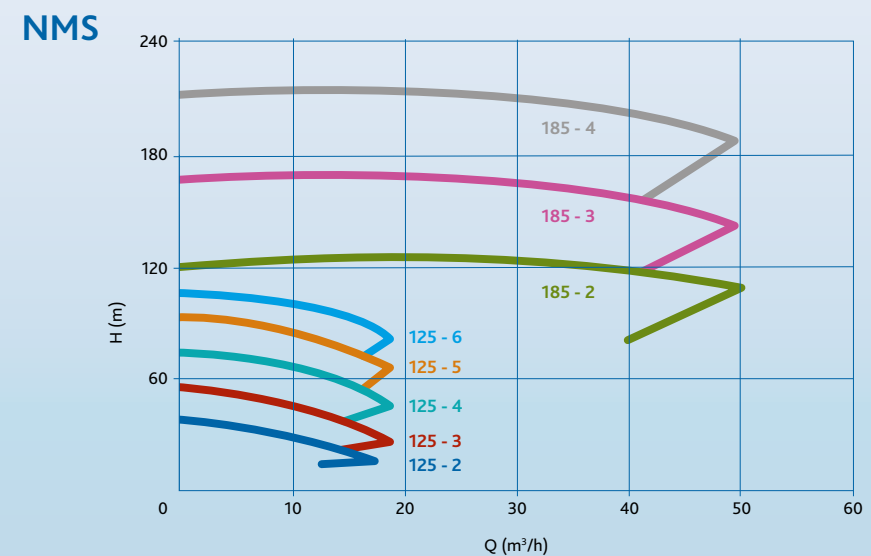



# Pump series IRP



## Characteristics

These air handling pumps have stainless steel 316L pump casings constructed in thick cold rolled plate, 100% non-porous and extremely smooth. The pumps have open or closed investment cast impellers, constructed in 316L or duplex materials. Together with an electropolished design the industrial air handling pump series IRP are a reliable component into your production process.

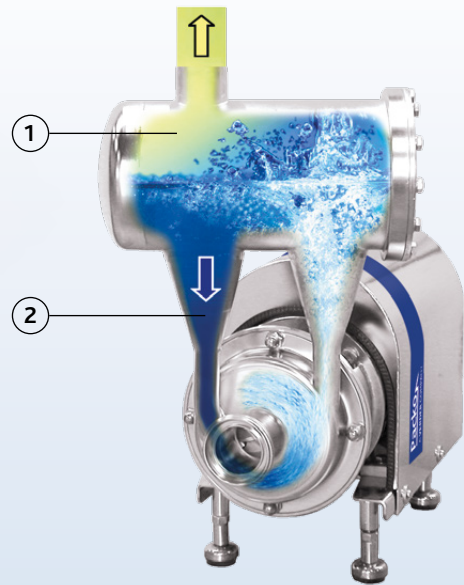
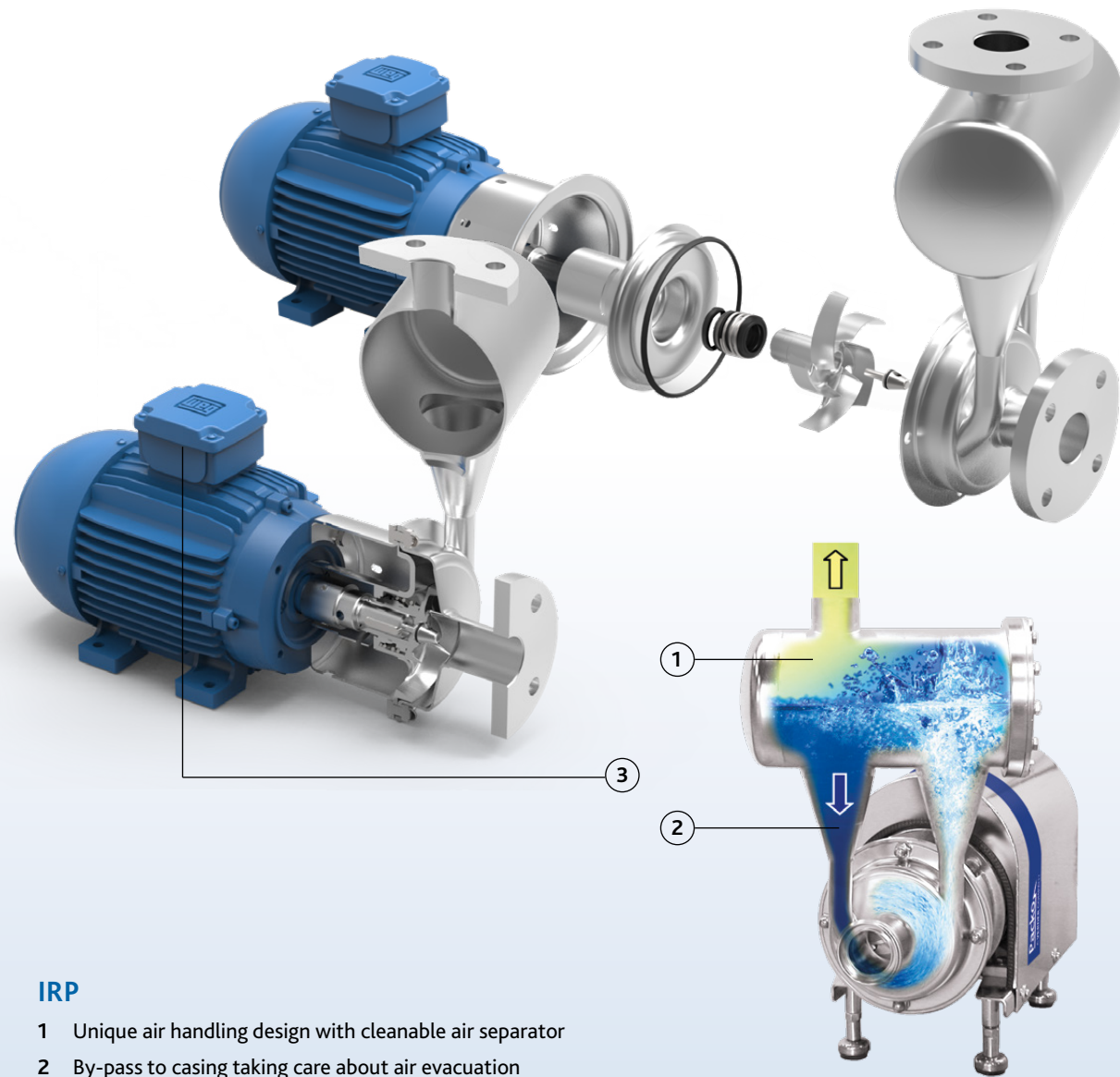

### IRP

- 1 Unique air handling design with cleanable air separator
- 2 By-pass to casing taking care about air evacuation
- 3 Monobloc execution with std. IEC motors
- 4 Standardized mechanical seals to EN 12756 bellow mechanical seals or balanced O-ring seals
- 5 One seal diameter: Ø 33 mm. Except for 80-160: Ø 43 mm

## Your benefits

- Higher pump efficiency compared with a classic liquid ring pump
- Low NPSH values: less risk on cavitation
- Electropolished: higher resistance against corrosion
- Easy & robust construction, easy to install and easy maintenance: less downtime
- Construction without non-return valve
- Easy to install
- 2 mechanical seal diameters for the entire range
- Limited noise level

## Application areas

Thanks to its unique air handling design based on a standard centrifugal pump, the IRP series are particularly suitable as a CIP return pump, as well as for unloading all type of collecting tankers and trucks.

### Pump series

Pump series	IRP
<b>Performance</b>	
max. flow rate	150 m <sup>3</sup> /h
max. differential head	75 m
max. inlet pressure	13 bar
max. liquid viscosity	10 cP
max. temperature	140 °C
impeller type	open or closed
max. free passage	22 mm
max. motor power	22 kW
max. speed	3000/3600 rpm
available frequency	50/60 Hz
<b>Technical specifications</b>	
materials wetted parts	stainless steel 316L or similar
mechanical seal configuration	single bellow, single balanced, quench, double
available O-ring materials	EPDM, FKM, FEP-FKM, FFKM or similar
connections	BSP fittings, flanges according to EN1092-1/01 & 02, ANSI flanges
surface finish	industrial, internal welds not hand polished, electropolished
certificates & legislation	Ex EAC

## Performance curves at 2900 rpm

### IRP

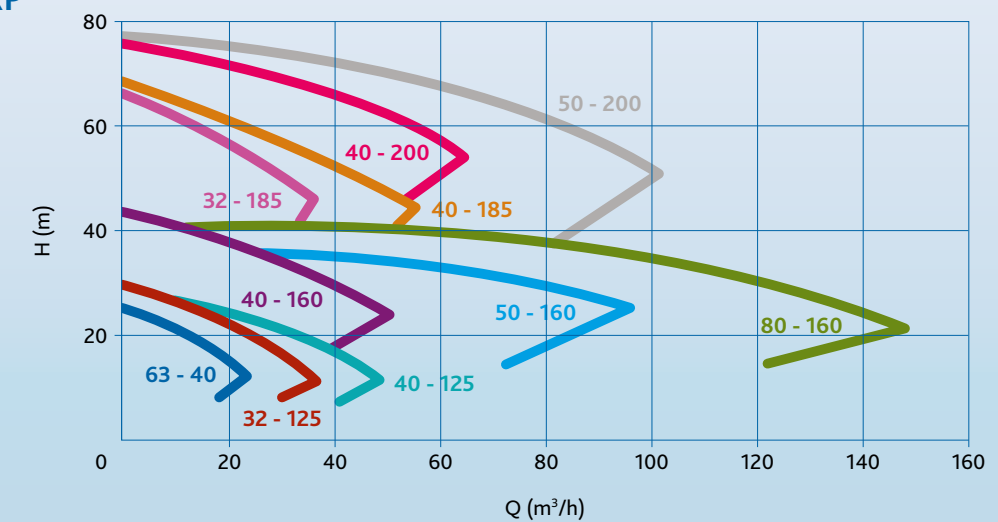

# Pump series IRP+



## Characteristics

These air handling pumps have stainless steel 316L pump casings constructed in thick cold rolled plate, 100% non-porous and extremely smooth. The pumps have open investment cast impellers, constructed in 316L or duplex materials. Together with an electropolished design the industrial air handling pump series IRP+ are a reliable component into your production process.

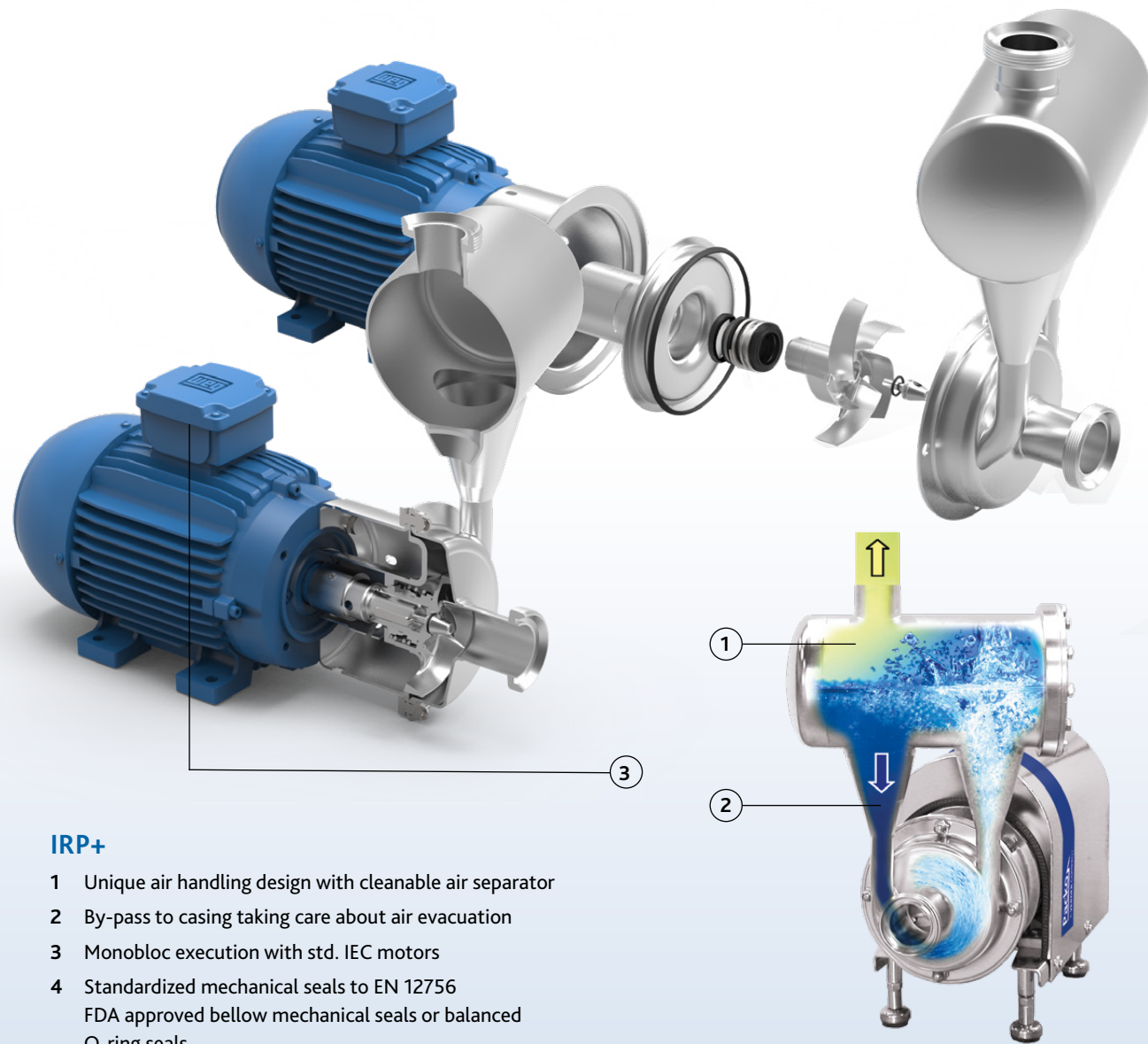

### IRP+

- 1 Unique air handling design with cleanable air separator
- 2 By-pass to casing taking care about air evacuation
- 3 Monobloc execution with std. IEC motors
- 4 Standardized mechanical seals to EN 12756  
FDA approved bellow mechanical seals or balanced O-ring seals
- 5 One seal diameter: Ø 33 mm







## Your benefits

- Higher pump efficiency compared with a classic liquid ring pump
- Low NPSH values: less risk on cavitation
- Electropolished: higher resistance against corrosion
- Easy & robust construction, easy to install and easy maintenance: less downtime
- Construction without non-return valve
- Easy to install
- 1 mechanical seal diameter for the entire range
- Limited noise level

## Application areas

Thanks to its unique air handling design based on a standard centrifugal pump, the IRP+ series are particularly suitable as a IRP+ return pump, as well as for unloading all type of collecting tankers and trucks.

Pump series	IRP+
<b>Performance</b>	
max. flow rate	105 m <sup>3</sup> /h
max. differential head	75 m
max. inlet pressure	13 bar
max. liquid viscosity	10 cP
max. temperature	140 °C
impeller type	open or closed
max. free passage	22 mm
max. motor power	22 kW
max. speed	3000/3600 rpm
available frequency	50/60 Hz
<b>Technical specifications</b>	
materials wetted parts	stainless steel 316L or similar
mechanical seal configuration	single bellow, single balanced, quench, double, pressurized barrier
available O-ring materials	EPDM, FKM, FEP-FKM, FFKM or similar
pump connections	hygienic fittings
surface finish	industrial, internal welds not hand polished, electropolished
certificates & legislation	   

## Performance curves at 2900 rpm

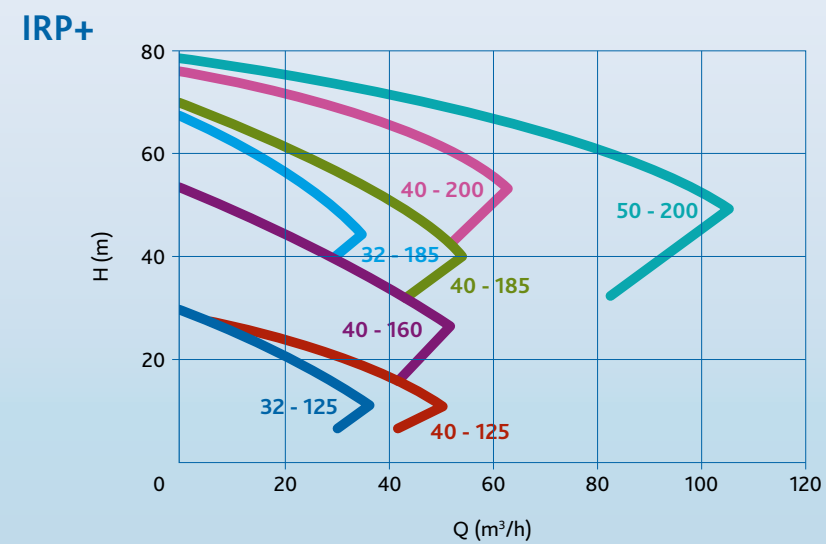



# Pump series MSP2



## Characteristics

These robust pumps have cast pump casings and open investment cast impellers in stainless steel 316L. Thanks to its solid construction and electropolished design these pumps are the reliable component for your production process. They can lift liquid from a lower level into the pump.

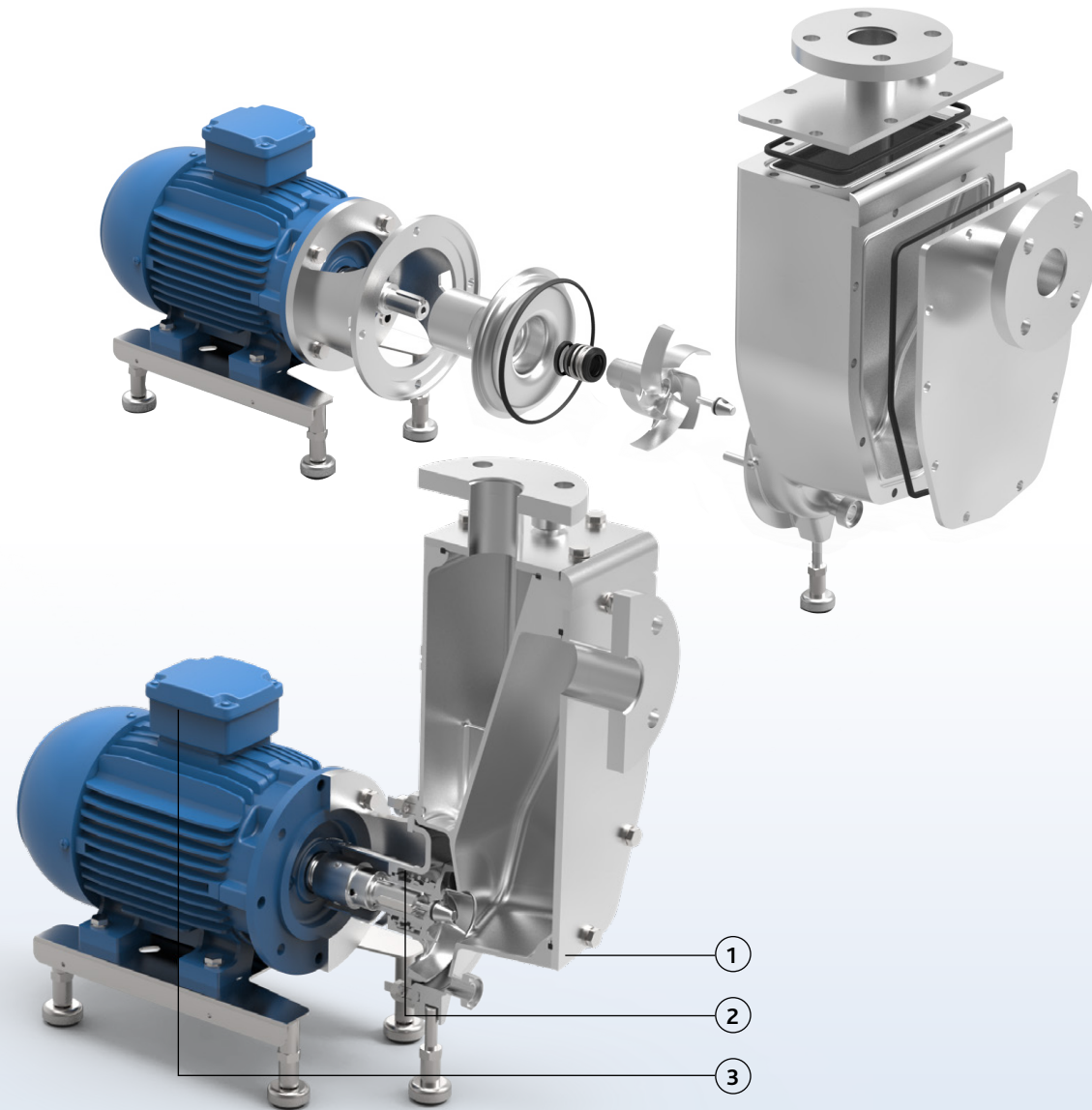

## MSP2

- 1 Solid design thanks to investment cast pump casings and impellers
- 2 Large seal cavity to guarantee liquid circulation around the seal
- 3 Monobloc execution with std. IEC motors
- 4 Standardized mechanical seals to EN 12756  
FDA approved bellow mechanical seals or balanced O-ring seals
- 5 One seal diameter for the entire range: Ø 33 mm







## Your benefits

- Self-priming
- Ideal for handling mixtures of liquid and air
- Electropolished: higher resistance against corrosion
- Easy and robust construction and easy maintenance: less downtime
- Easy to install
- 1 mechanical seal diameter for entire range
- Standard components

## Application areas

These robust self-priming pumps are often used for handling pure and slightly contaminated liquids, they are often used for unloading applications as well as for CIP return, etc.

The Packo pumps of the MSP2 series are self-priming pumps used in a big variety of industries.

Pump series	MSP2
<b>Performance</b>	
max. flow rate	70 m <sup>3</sup> /h
max. differential head	40 m
max. inlet pressure	3 bar
max. liquid viscosity	10 cP
max. temperature	140 °C
impeller type	open
max. free passage	22 mm
max. motor power	11 kW
max. speed	3000/3600 rpm
available frequency	50/60 Hz
<b>Technical specifications</b>	
materials wetted parts	stainless steel 316L or similar
mechanical seal configuration	single bellow, single balanced, quench, double
available O-ring materials	EPDM, FKM, FFKM
connections	hygienic fittings, BSP fittings, flanges according to EN1092-1/01 & 02, ANSI flanges
surface finish	industrial, internal welds not hand polished, electropolished
certificates & legislation	   

## Performance curves at 2900 rpm

### MSP2

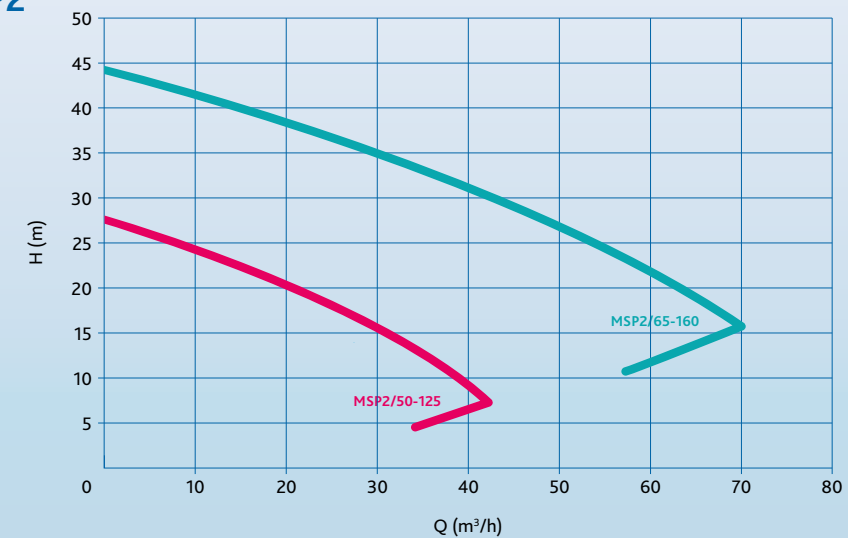

# Pump series IFF

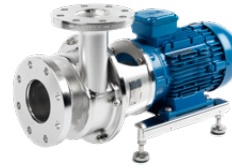

## Characteristics

These robust pumps have stainless steel 316L pump casings constructed in thick cold rolled plate and can be equipped with open or vortex investment cast impellers stainless steel 316L or similar. The pumps have a large clearance between the impeller and the pump casing and as a result they can handle solids, fibres, foils and leaves without any risk of clogging. Thanks to its solid construction and electropolished design these pumps are the reliable component for your production process.

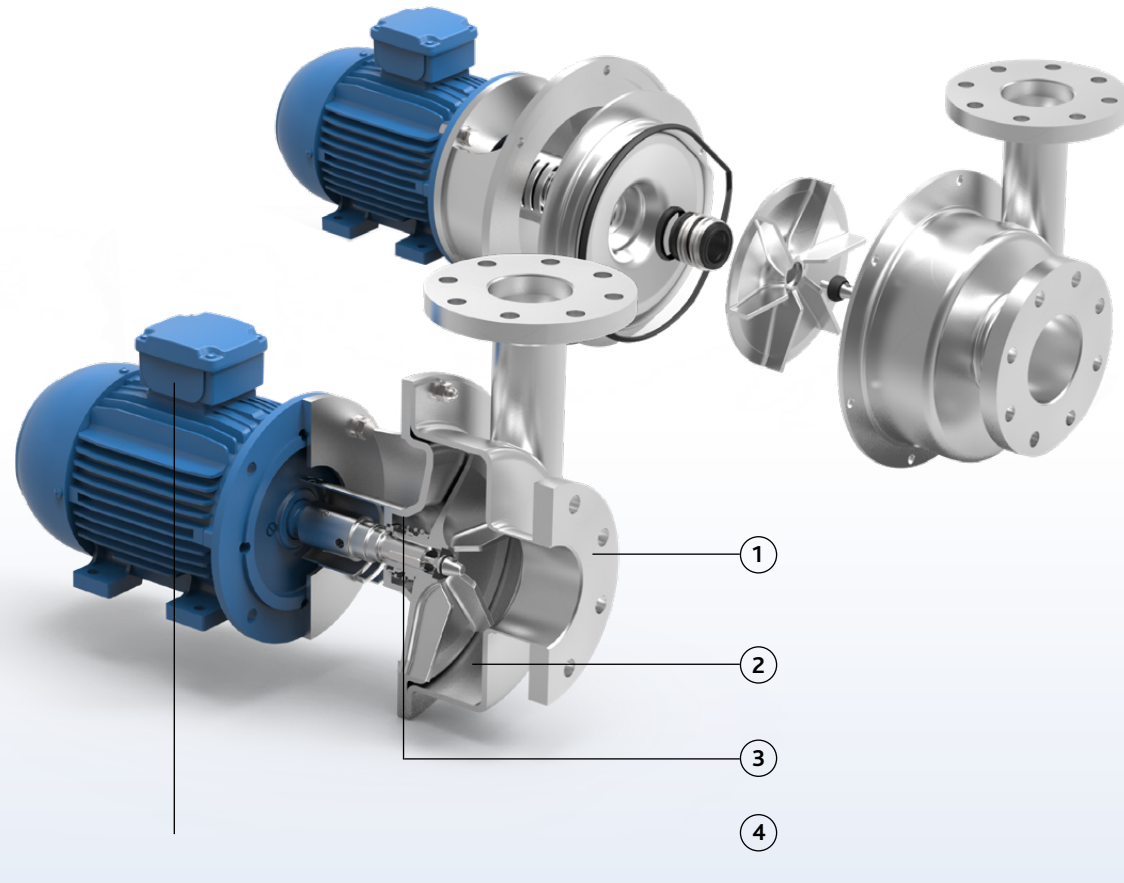

### IFF

- 1 Pressed stainless steel, pump casing thickness up to 8 mm, back plate up to 30 mm
- 2 Large clearance between impeller and pump casing
- 3 Large seal cavity to guarantee liquid circulation around the seal
- 4 Monobloc execution with std. IEC motors
- 5 Standardized mechanical seals to EN 12756  
FDA approved bellow mechanical seals or balanced O-ring seals



Bellow seal

## Your benefits

- Non-clogging, suitable for handling liquids with solids, fibres, foils and / or leaves
- Electropolished: higher resistance against corrosion
- Easy & robust construction and easy maintenance: less downtime
- Easy to install
- Solid impellers in investment cast material
- Standard components

## Application areas

The Packo pumps of the series IFF are used in a wide range of industries and applications.

You can find them in just about all industries such as vegetable industry, water treatment and textile industry as well as in e.g. biogas, biodiesel and bioethanol applications.

Typically the pumps are transferring liquids with fibres and solids coming from washing or blanching vegetables, potato waste, circulation of liquids on digesters, etc.

Pump series	IFF
<b>Performance</b>	
max. flow rate	360 m <sup>3</sup> /h
max. differential head	35 m
max. inlet pressure	13 bar
max. liquid viscosity	500 cP
max. temperature	140 °C
impeller type	open or vortex
max. free passage	35 mm
max. motor power	90 kW
max. speed	1500/1800 rpm
available frequency	50/60 Hz
<b>Technical specifications</b>	
materials wetted parts	stainless steel 316L or similar
mechanical seal configuration	single bellow, single balanced, quench, double, pressurized barrier
available O-ring materials	EPDM, FKM, FEP-FKM
connections	BSP fittings, flanges according to EN1092-1/01 & 02, ANSI flanges
surface finish	industrial, internal welds not hand polished, electropolished
certificates & legislation	

## Performance curves at 1450 rpm

### IFF

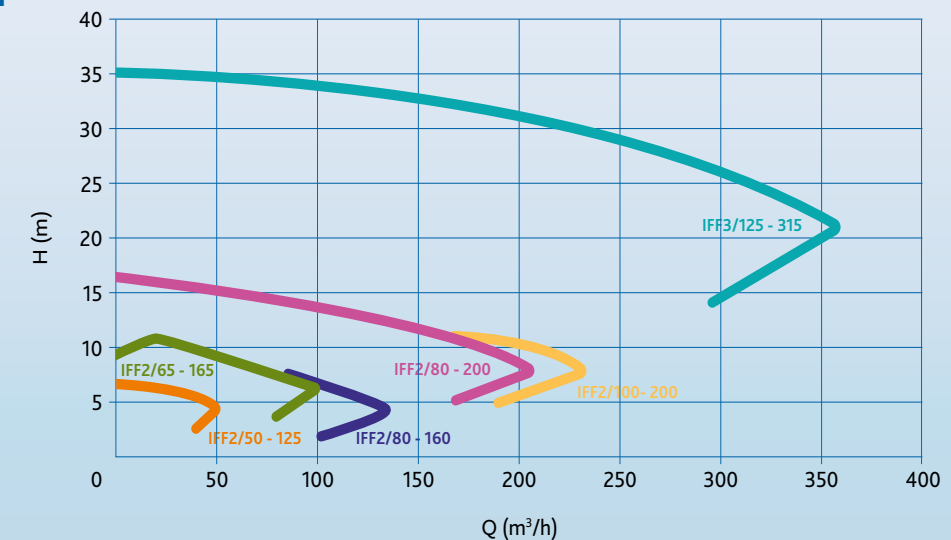



# Pump series MFF



## Characteristics

These robust pumps have stainless steel 316L investment cast pump casings and can be equipped with open, semi-open or vortex investment cast impellers in stainless steel 316L or similar. The pumps have a large clearance between the impeller and the pump casing and as a result they can handle solids and fibres without any risk of clogging. Thanks to its solid construction and electropolished design these pumps are the reliable component for your production process.

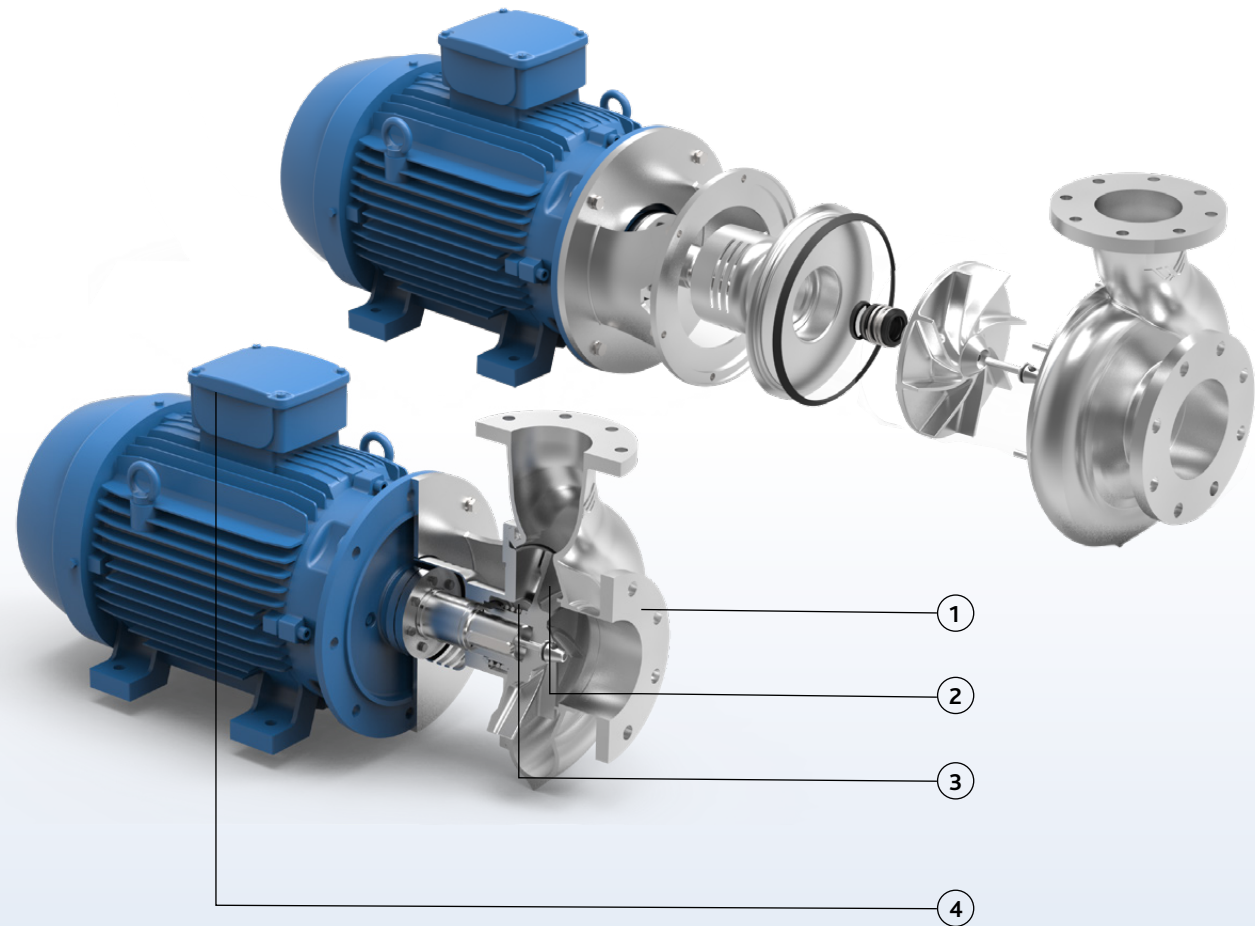

### MFF

- 1 Investment cast stainless steel pump casings
- 2 Large clearance between impeller and pump casing
- 3 Large seal cavity to guarantee liquid circulation around the seal
- 4 Monobloc execution with std. IEC motors
- 5 Standardized mechanical seals to EN 12756  
FDA approved bellow mechanical seals or balanced O-ring seals



Bellow seal

## Your benefits

- Non-clogging, suitable for handling liquids with solids and / or fibres
- Electropolished: higher resistance against corrosion
- Easy & robust construction and easy maintenance: less downtime
- Easy to install
- Solid impellers in investment cast material
- Standard components

## Application areas

The Packo pumps of the series MFF are used in a wide range of industries and applications. You can find them in just about all industries such as vegetable industry, water treatment and textile industry as well as in e.g. biogas, biodiesel and bioethanol applications. Typically the pumps are transferring liquids with fibres and solids coming from washing or blanching vegetables, potato waste, circulation of liquids on digesters, etc.

Pump series	MFF
<b>Performance</b>	
max. flow rate	750 m <sup>3</sup> /h
max. differential head	30 m
max. inlet pressure	12 bar
max. liquid viscosity	500 cP
max. temperature	140 °C
impeller type	open or vortex
max. free passage	50 mm
max. motor power	250 kW
max. speed	1500/1800 rpm
available frequency	50/60 Hz
<b>Technical specifications</b>	
materials wetted parts	stainless steel 316L or similar
mechanical seal configuration	single bellow, single balanced, quench, double, pressurized barrier
available O-ring materials	EPDM, FKM, FEP-FKM
connections	BSP fittings, flanges according to EN1092-1/01 & 02, ANSI flanges
surface finish	industrial, internal welds not hand polished, electropolished
certificates & legislation	

## Performance curves at 1450 rpm

### MFF

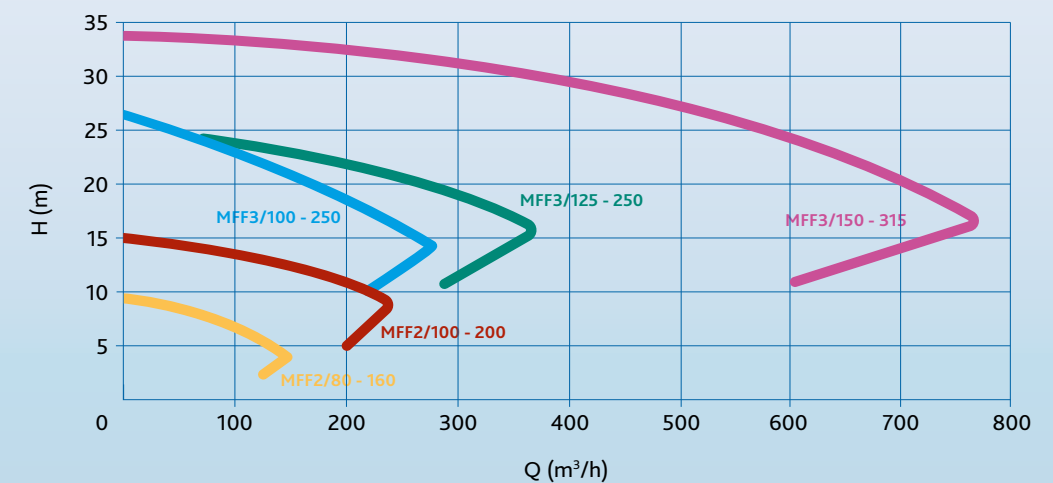

# Pump series VPCP

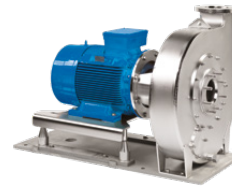

## Characteristics

The Packo stainless steel pumps of the VPCP series are the reference in gentle and damage free pumping of vegetables, potatoes, mussels, shrimps, etc. Due to the fact that they have an extremely large passage and to its specially designed vane they guarantee a smooth handling of your product.

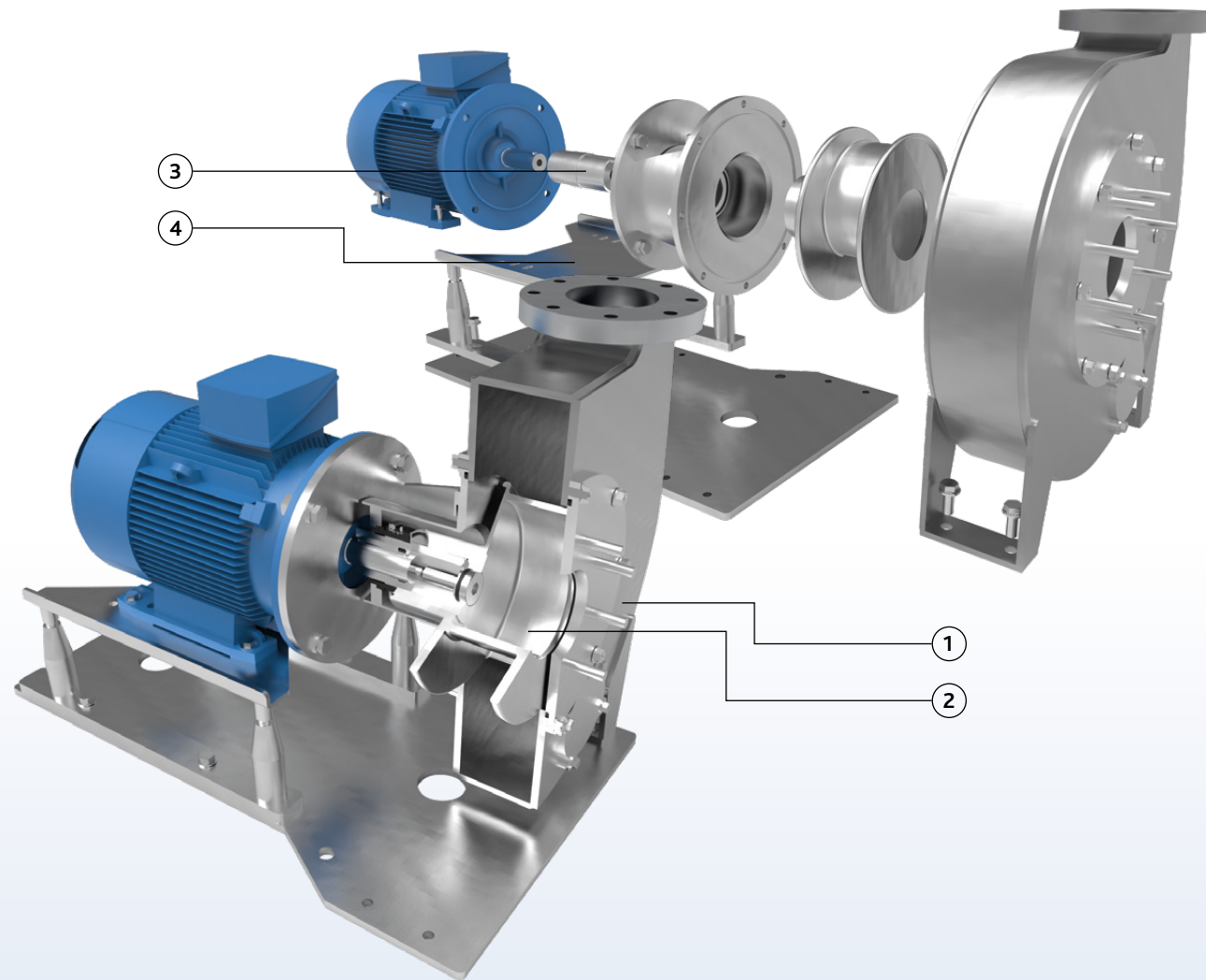

### VPCP

- 1 Electropolished: corrosion resistant, no rusting
- 2 Especially designed vane with large passage: pumping without product damage
- 3 Duplex stub shaft allows a quick and easy disassembly of the vane
- 4 Sledge construction: pump can be easily slid backwards while the pump casing remains in the piping system: short downtimes
- 5 Standardized FDA approved rubber bellow mechanical seals to EN 12756,
- 6 2 sizes for the entire range:
  - seal diameter Ø 80 mm up to 11 kW
  - motor power ≥ 18,5 kW: Ø 110 mm
- 7 Also available in horizontal version: HPCP



Bellow seal



## Your benefits

- Gentle and damage-free pumping
- Easy maintenance: short downtimes
- Extremely large passage
- Electropolished stainless steel 304L: no rusting & easy to clean
- Monobloc design: space saving

## Application areas

The Packo VPCP pump range is specifically designed for damage-free pumping of potatoes and vegetables but also seafood such as mussels, cockles and shrimp.

The VPCP pump can be used in Belgian fries process lines, transport of vegetables to blanching lines as well as for transport of pasta from pasta cookers.

Pump series	VPCP
<b>Performance</b>	
max. flow rate	1000 m <sup>3</sup> /h
max. differential head	20 m
max. liquid viscosity	100 cP
max. temperature	80 °C
impeller type	special designed vane
max. free passage	213 mm
max. motor power	55 kW
max. speed	1200 rpm
available frequency	50/60 Hz
<b>Technical specifications</b>	
materials wetted parts	stainless steel 304 or similar
mechanical seal configuration	single
available O-ring materials	NBR (FDA)
connections	industrial
surface finish	industrial finish: welds are not hand polished final surface treatment: electropolished
certificates & legislation	  

## Performance curves

VPCP/125-315 Ø 105mm

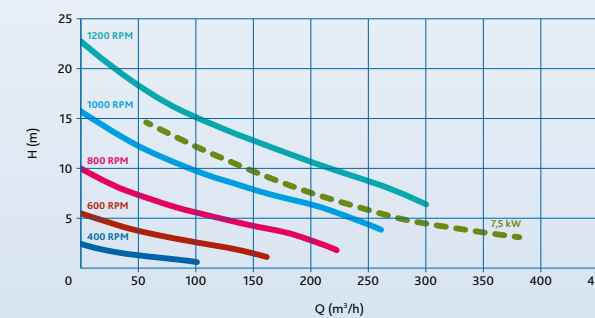

VPCP/200-500 Ø 171mm

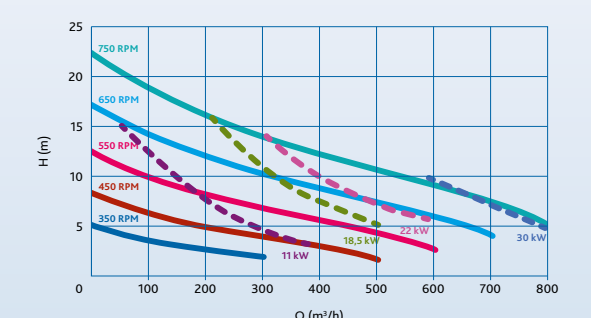

VPCP/150-400 Ø 133mm

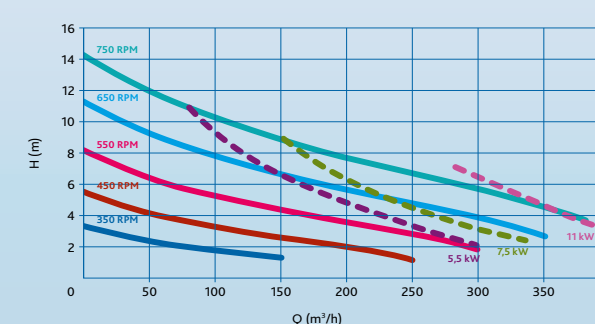

VPCP/250-630 Ø 213mm

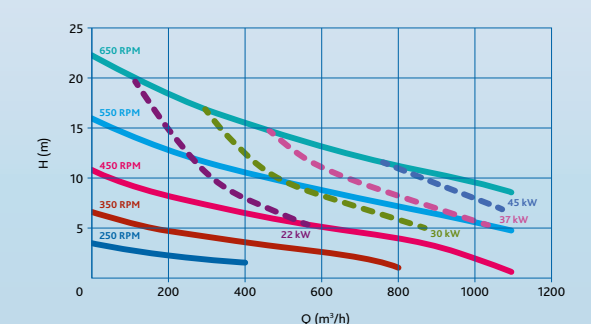



# Pump series IML



## Characteristics

The Packo submersible cantilever pump series IML are designed for installation in a sump or tank, having only the casing and impeller submerged. Because the absence of a mechanical seal and slide bearing in contact with the liquid, the cantilever pumps are maintenance friendly and reduce the downtime. These robust pumps have stainless steel 316L pressed or investment cast pump casings and can be equipped with open, semi-open, closed and vortex impellers. Thanks to its solid construction and electropolished design these pumps are the reliable component for your production process. Available in NP, ICP, MCP, IFF and MFF version with open, semi-open, closed or vortex impellers.

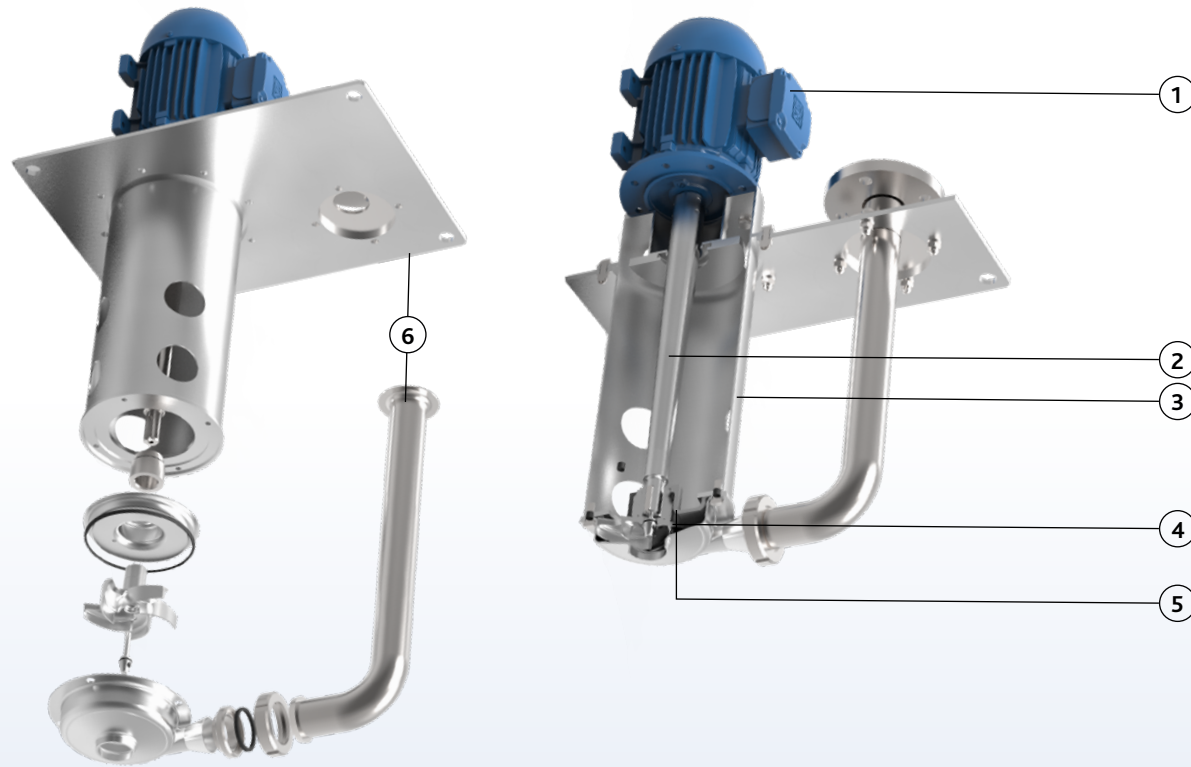

### IML

- 1 Use of standard IEC motors
- 2 Tapered shaft, fully machined
- 3 High strength column support pipe. Rigidly maintains alignment between motor and casing. Protects pump shaft.
- 4 Cantilever design = no mechanical seals, no plain bearings.  
Reduced downtime and operating costs. No bottom bearing, no oil or water pipes required to lubricate these bearings.
- 5 Renewable "labyrinth" shaft sleeve to minimize blow-back of liquid around the shaft.  
Additional shaft protection against abrasive liquids.
- 6 Optional: stainless steel base plate and outlet pipe

## Your benefits



- Cantilever design = leakage free, no seals and plain bearings
- Sealless pump: reducing downtime and operating costs
- Not sensitive for dry running
- Easy construction
- Electropolished: higher resistance against corrosion and sticky liquids
- Robust design
- Available with different impellers

## Application areas

They are used in applications for liquids which are difficult to seal with a mechanical seal.

The Packo submersible cantilever pump series IML are used in a wide range of industries and applications such as metal finishing industry, industrial spray washers, water treatment, galvanizing and coating industry, chemical industry, etc.

They are handling degreasing, pickling & phosphatizing liquids, slurries, hot oils, process and industrial wastes, corrosive liquids, condensate, etc.

Pump series	IML
<b>Performance</b>	
max. flow rate	1000 m <sup>3</sup> /h
max. differential head	60 m
max. pump length	500 mm
max. liquid viscosity	1000 cP
max. temperature	200 °C
impeller type	open, semi-open, closed or vortex
max. free passage	45 mm
max. motor power	132 kW
max. speed	3000 rpm
available frequency	50 / 60 Hz
<b>Technical specifications</b>	
materials wetted parts	stainless steel 316L or similar
mechanical seal configuration	no seal - cantilever
available O-ring materials	EPDM, FKM
connections	hygienic fittings, BSP fittings, flanges according to EN1092-1/01 & 02, ANSI flanges
surface finish	industrial, welds not hand polished, electropolished
certificates & legislation	  

## Performance curves

### IML

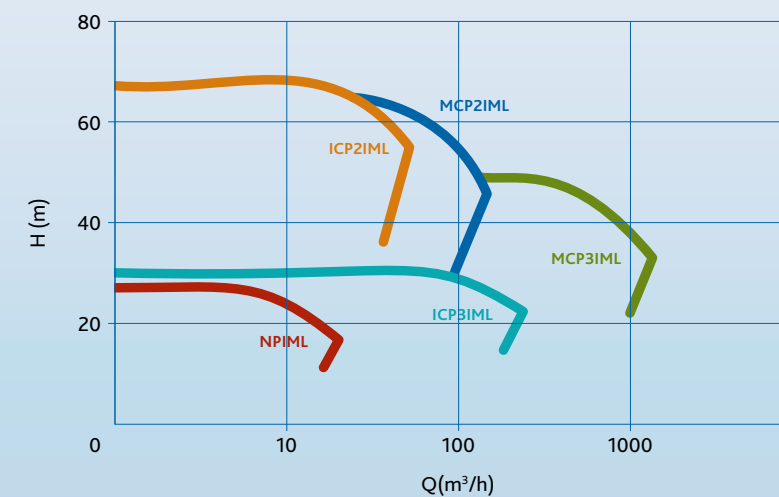

# Pump series IMO



## Characteristics

The Packo pumps of the IMO series are cantilever pumps that are placed next to a reservoir. They are suitable for pumping liquids with a temperature up to 200 °C. They are especially constructed to handle liquids that are difficult to seal such as paints, varnishes, galvanic coatings, hot frying oil, etc.

The pumps have a working length of 500 mm. (= maximum level of the liquid above the suction of the pump). De MCP3IMO pumps are also available on pedestal with a working length of 900 mm.

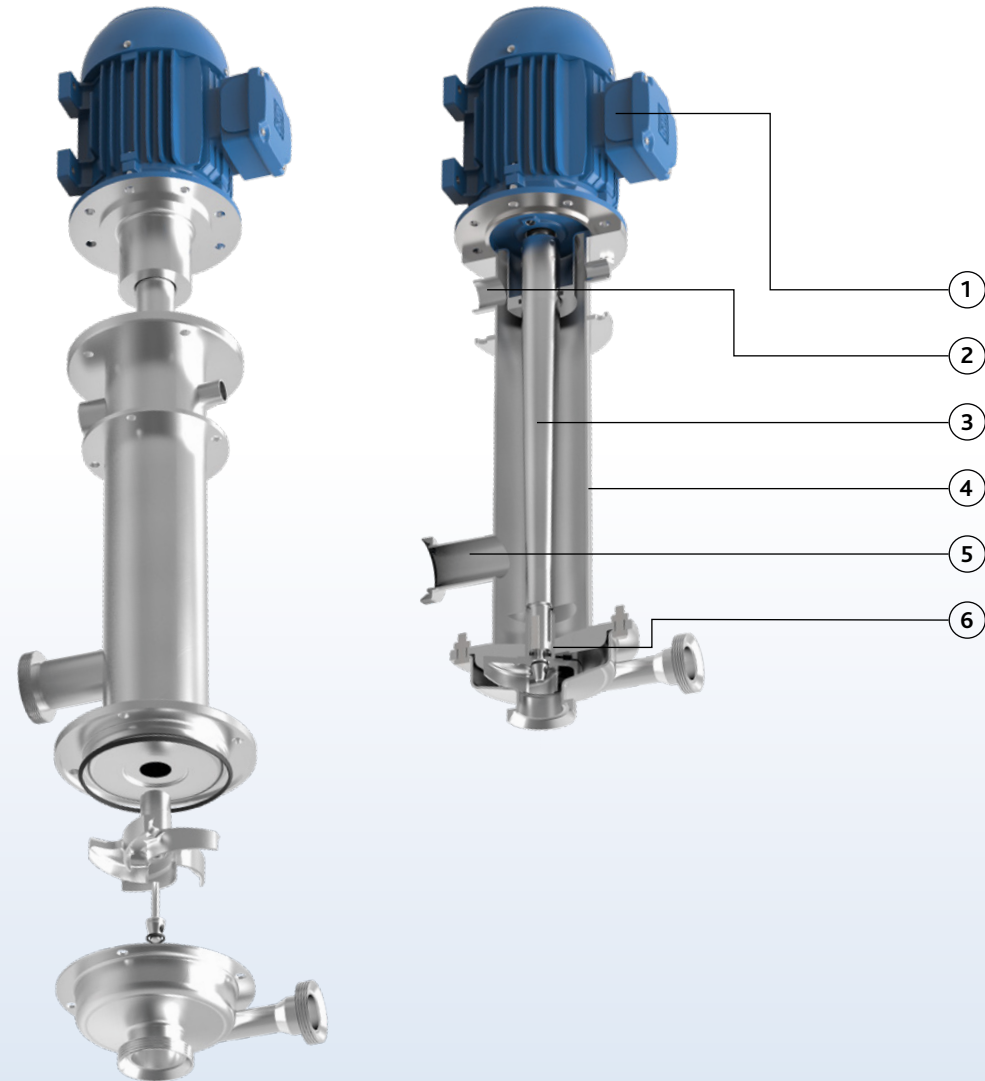

### IMO

- 1 Use of standard IEC motors
- 2 Connection for cleaning purposes
- 3 Tapered shaft, fully machined
- 4 High strength column support pipe. Rigidly maintains alignment between motor and casing. Protects pump shaft.
- 5 By-pass for overflow
- 6 Cantilever design = no mechanical seals, no plain bearings. Reduced downtime and operating costs. No bottom bearing, no oil or water pipes required to lubricate these bearings.



## Your benefits

- Cantilever design = leakage free (no seals and plain bearings)
- Sealless pump: reducing downtime and operating costs
- Electropolished: easy to clean
- Robust design
- Not sensitive for dry running

## Application areas

Particularly suitable for pumping liquids that are difficult to seal such as hot frying oil up to 200 °C.

They are also used for pumping waste water from industrial waste such as CIP, acids, condensate, etc.

Pump series	IMO
<b>Performance</b>	
max. flow rate	1000 m <sup>3</sup> /h
max. differential head	60 m
max. inlet pressure	atmospheric
max. liquid viscosity	1000 cP
max. temperature	200 °C
impeller type	open, semi-open or closed
max. free passage	45 mm
max. motor power	132 kW
max. speed	3000 rpm
available frequency	50/60 Hz
<b>Technical specifications</b>	
materials wetted parts	stainless steel 316L or similar
mechanical seal configuration	no seal - cantilever
available O-ring materials	FKM - EPDM - Special
connections	industrial or hygienic
surface finish	industrial finish: welds are not hand polished. final surface treatment: electropolished
certificates & legislation	  

## Performance curves

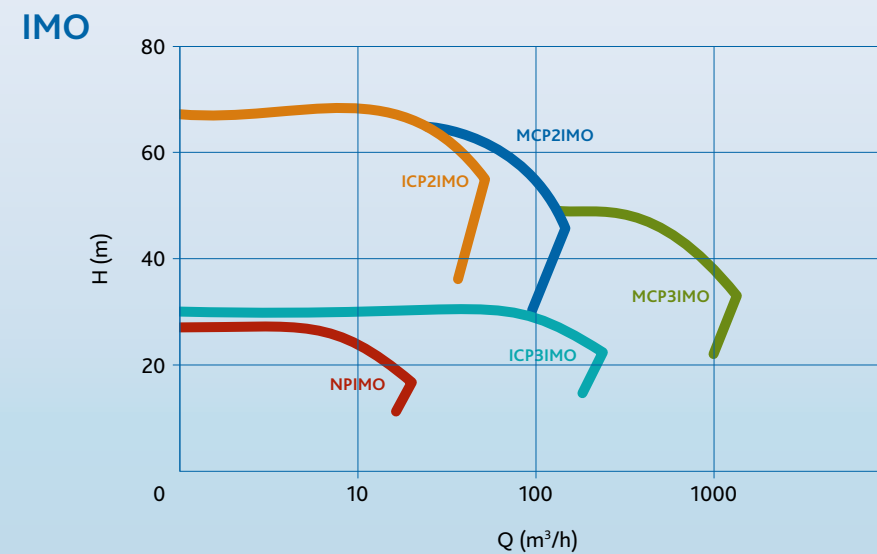



# Pump series IMXL



## Characteristics

The Packo vertical sump pump series IMXL are designed for installation in a sump or tank, having only the casing and impeller submerged. The pumps have a length of 1500 mm having a shaft supported by a slide bearing in the liquid.

These robust pumps have stainless steel 316L pressed or investment cast pump casings and can be equipped with open, semi-open, closed impellers and vortex impellers. Thanks to its solid construction and electropolished design these pumps are the reliable component for your production process.

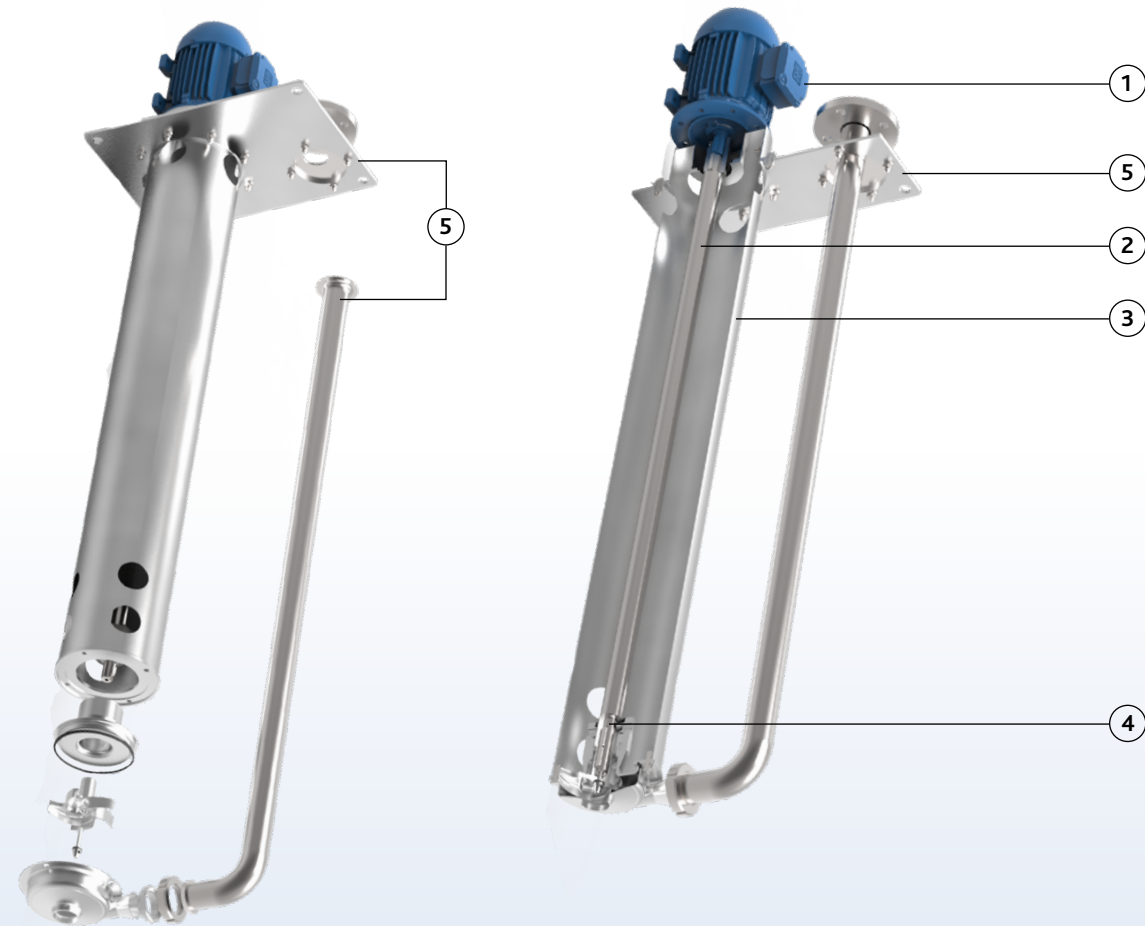

### IMXL

- 1 Use of standard IEC motors
- 2 Tapered shaft, fully machined
- 3 High strength column support pipe. Rigidly maintains alignment between motor and casing. Protects pump shaft.
- 4 Executed with slide bearing in carbon / stainless steel or Silicon carbide / silicon carbide materials. No dry running allowed, additional flushing pipes for oil or water are available as an option.
- 5 Optional: stainless steel base plate and outlet pipe



## Your benefits

- Pump length up to 1500 mm in 'monobloc' design
- Easy and robust construction
- Easy maintenance
- Electropolished: higher resistance against corrosion and sticky liquids
- Available with different impellers

## Application areas

The Packo submersible cantilever pump series IMXL are used in a wide range of industries and applications such as metal finishing industry, industrial spray washers, water treatment, galvanizing and coating industry, chemical industry, etc.

They are handling degreasing, pickling & phosphatizing liquids, slurries, hot oils, process and industrial wastes, corrosive liquids, condensate, etc.

Pump series	IMXL
<b>Performance</b>	
max. flow rate	300 m <sup>3</sup> /h
max. differential head	28 m
max. pump length	1500 mm
max. liquid viscosity	1000 cP
max. temperature	120 °C
impeller type	open, semi-open or closed
max. free passage	45 mm
max. motor power	22 kW
max. speed	1500 rpm
available frequency	50/60 Hz
<b>Technical specifications</b>	
materials wetted parts	stainless steel 316L or similar
mechanical seal configuration	no mechanical seals, with slide bearings
available O-ring materials	EPDM, FKM, FEP-FKM, silicone
connections	hygienic fittings, BSP fittings, flanges according to EN1092-1/01 & 02, ANSI flanges
surface finish	industrial, welds not hand polished, electropolished
certificates & legislation	  

## Performance curves

### IMXL

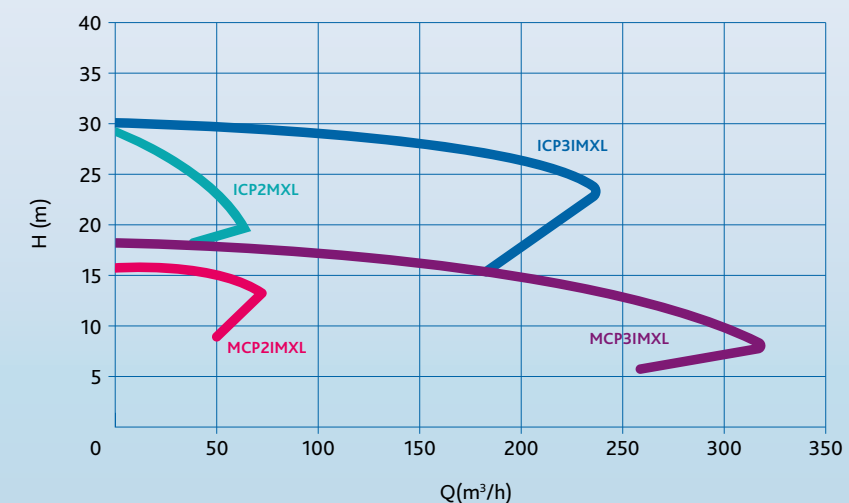

## Options IML and IMXL

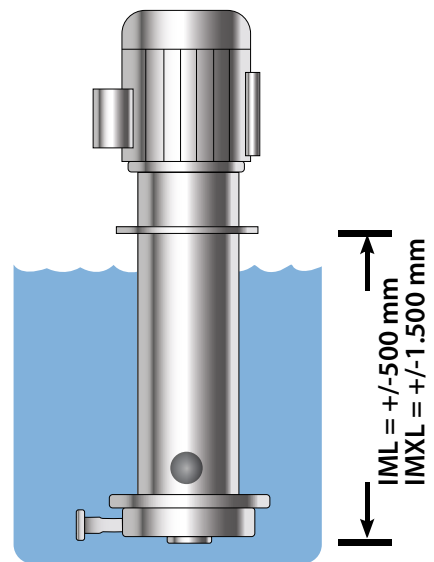

**1** Basic version (code W)

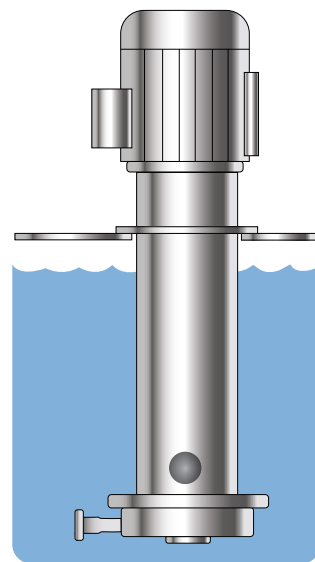

**2** Version (code V) with base plate

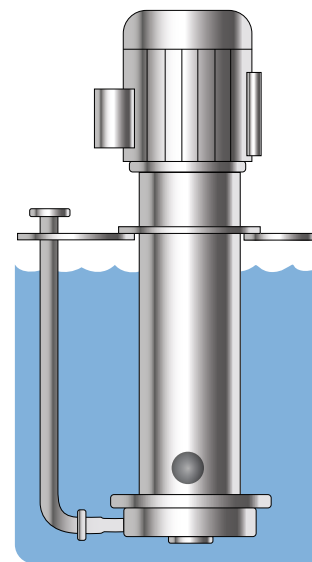

**3** Version (code O) with base plate and column pipe

## Options IMO

Version IMO, in which the pump is placed outside the vessel.  
A bypass connection (A) must be utilised as an overflow.

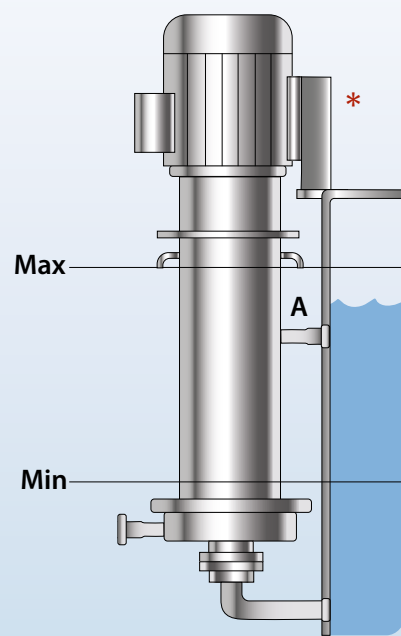

**1** Basic version (code W)

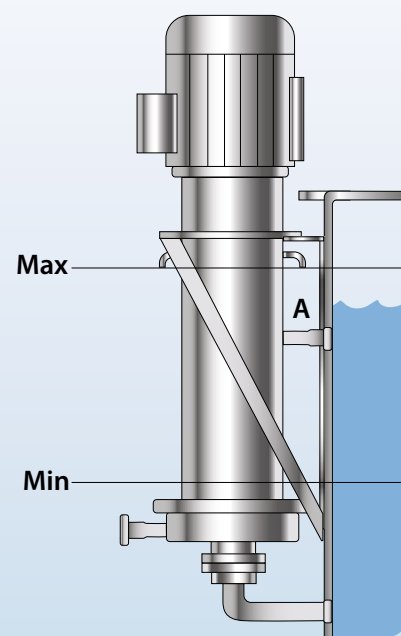

**2** Version with mounting base (code V)

\* mounting support to be provided by the customer

## Standard Packo pump range

### Hygienic pumps



#### Pump series FP60

Low cost hygienic pump executed in pressed stainless steel. Energy saving thanks to high efficiency.

**Easy concept and maintenance.**

- Max. flow up to 40 m<sup>3</sup>/h
- Max. head 27 m
- Motor power up to 2.2 kW



#### Pump series FP1

The best 'value for money' hygienic stainless steel centrifugal pump.

Energy-saving with high efficiency.

Modular concept built up with standard components.

**Easy maintenance.**

- Max. flow up to 55 m<sup>3</sup>/h
- Max. head 37 m
- Motor power to 5.5 kW



#### Pump series FP2

Robust executed hygienic pump in stainless steel 316L. Energy saving and very low NPSH.

Modular concept composed with standard components.

**Easy maintenance.**

- Max. flow up to 110 m<sup>3</sup>/h
- Max. head 220 m
- Motor power up to 90 kW



#### Pump series FP2+

**3A certified**

Robust sanitary pump in stainless steel 316L.

Energy saving and very low NPSH.

Modular concept built up with standard components.

**Easy maintenance.**

- Max. flow up to 110 m<sup>3</sup>/h
- Max. head 110 m
- Motor power up to 45 kW



## Hygienic centrifugal pumps



### Pump series FP3

EHDG certified

Robust executed hygienic pump in stainless steel 316L.  
Energy saving and very low NPSH.

Modular concept composed with standard components.

Easy maintenance.

- Max. flow up to 320 m<sup>3</sup>/h
- Max. head 120 m
- Motor power up to 90 kW

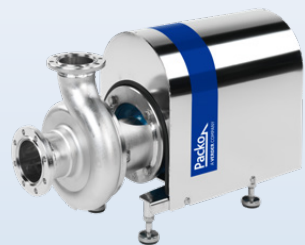

### Pump series MFP2 & MFP3

Hygienic execution in cast stainless steel 316L.

Extreme energy saving thanks to optimum pump hydraulics.

Modular concept composed with standard components.

Easy maintenance.

- Max. flow up to 1800 m<sup>3</sup>/h
- Max. head 75 m
- Motor power up to 250 kW



### Pump series FMS

Hygienic executed multistage pump.

Ideal for working at moderate flow rate and high pressures.

- Max. flow up to 50 m<sup>3</sup>/h
- Max. head 215 m
- Motor power up to 45 kW



### Pump series FPP2 & FPP3

Hygienic high pressure pump suitable for system pressures up to 40 bar!

Made of solid, machined stainless steel 316L.

Especially for use in reverse osmosis applications.

- Max. flow up to 200 m<sup>3</sup>/h
- Max. head 110 m
- Motor power up to 45 kW

## Air handling hygienic centrifugal pumps



### Pump series CRP+

3A certified CIP return pump.

Unique air handling concept.

Limited noise level.

Easy maintenance.

- Max. flow up to 105 m<sup>3</sup>/h
- Max. head 75 m
- Motor power up to 22 kW



### Pump series CRP

CIP return pump.

Unique air handling concept. High efficiency and low NPSH in comparison with a classic liquid ring pump.

Limited noise level.

Easy maintenance.

- Max. flow up to 150 m<sup>3</sup>/h
- Max. head 75 m
- Motor power up to 22 kW



### Pump series MSCP

Self-priming side channel pump with exceptional suction power and air handling capacity.

Used in applications where air must be pumped in against a high back pressure in the discharge line.

- Max. flow up to 40 m<sup>3</sup>/h
- Max. head 75 m
- Motor power up to 15 kW



### Pump series GFP

Hygienic multiphase pump, combination of a standard centrifugal pump and a liquid ring pump both mounted together on 1 motor and 1 shaft.

Ideal for foaming liquids and (viscous) liquids containing gas.

- Max. flow up to 400 m<sup>3</sup>/h
- Max. head 30 m
- Motor power up to 45 kW

## Hygienic volumetric pumps



### Pump series ZP

The Packo ZP Circumferential Piston Pumps are the perfect solution for use in the most difficult applications, e.g. critical suction conditions, high temperatures or abrasive fluids. [Use of small clearances in combination with non-galling materials provide maximum efficiency and operational reliability.](#)

- Max. flow up to 42 m<sup>3</sup>/h
- Max. product viscosity 1.000.000 cP
- Max. differential pressure 15 bar
- Max. temperature 180°C



### Pump series ZL

The Packo pumps of the ZL series are designed for a wide range of hygienic applications in dairies, breweries, the pharma and cosmetics industry and bakeries, as well as for pumping liqueurs, detergents, shampoos, gels, etc. [They are the ideal solution for gentle pumping of low to high viscous liquids.](#)

- Max. flow up to 100 m<sup>3</sup>/h
- Max. product viscosity 1.000.000 cP
- Max. differential pressure 20 bar
- Max. temperature 150°C



### Pump series ZS

The Packo ZS twin screw pumps were designed for pumping low to high viscous and gaseous liquids in hygienic applications in dairies, breweries, the pharma and cosmetics industry and bakeries.

[The ideal positive displacement pump for gentle pumping of viscous liquids without damaging contained solids, such as fruit in yoghurt, nuts in ice cream, etc.](#)

- Max. flow up to 100 m<sup>3</sup>/h
- Max. product viscosity 1.000.000 cP
- Max. differential pressure 12 bar
- Max. temperature 150°C

## Dispergation technologies



### High Shear pump series SFP2 & SFP3

Based on the FP2 pump series with open impeller and FP3 with closed impeller.

Stator specially designed with ANSYS CFD package (patented).

Efficiency improvement between 70 and 100% in comparison with currently available technologies. Very energy efficient thanks to its high efficiency.

- Max. flow up to 200 m<sup>3</sup>/h
- Max. head 55 m
- Motor power up to 45 kW
- Max. shear up to 100.000 s<sup>-1</sup>



### Colloid mill series CM

The CM is a hygienic colloid mill with toothed rotor and stator in electropolished duplex stainless steel. They are used to grind particles in suspension precisely and with reproducible results in an annular gap between the stator and rotor which can be adjusted by changing the axial position of the rotor. The rotor and stator contain 2 milling zones and thanks to the high shear forces between rotor and stator the CM will also mix the fluid..

- Max. flow up to 15 m<sup>3</sup>/h
- Max. head 35 m with water
- Motor power up to 45 kW



**Packo**

A VERDER COMPANY

We optimize your flow



Watch the Packo pumps video.

Packo Inox Ltd • Industriepark Heernisse • Cardijnlaan 10 • 8600 Diksmuide • BELGIUM  
Tel. +32-51-51 92 80 • Fax +32-51-51 92 99 • E-mail [pumps@packo.com](mailto:pumps@packo.com) • [www.packopumps.com](http://www.packopumps.com)  
LinkedIn: [www.linkedin.com/company/packopumps](http://www.linkedin.com/company/packopumps)