

LECTURE NOTES

ON

INDUSTRIAL WASTEWATER TREATMENT

Course Code: (A70139)

IV B.Tech Civil - I Semester

SRINIVAS ANGADI

Asst. Professor in Civil Engineering



CIVIL ENGINEERING

INSTITUTE OF AERONAUTICAL ENGINEERING

(AUTONOMOUS)

DUNDIGAL, HYDERABAD - 500 043

INDUSTRIAL WASTEWATER TREATMENT

UNIT I

Sources of Industrial Waste

Industrial wastewater means used up water from industries. The characteristics of waters depend on the nature of industry.

Generally pollution properties are:

Physical pollution	- Temperature ,Colour ,Odour ,Taste ,Solids
Chemical pollution	- pH, Acidity, Dissolved salts
Organic pollution	- Organic Matter
Biological pollution	- Biological Activities

The industrial wastes either join the streams or other natural water bodies directly, or are emptied into the municipal sewers. These wastes affect the normal life of stream or the normal functioning of sewerage and sewage treatment plant. Streams can assimilate certain amount of wastes before they are "polluted".

Three alternatives for the disposal of the industrial wastes.

1. The direct disposal of the waste into the streams without any treatment.
2. Discharge of the wastes into the municipal sewers for combined treatment.
3. Separate treatment of the industrial wastes before discharging the same into the water bodies.

The selection of particular process depends on various factors:

1. Self Purification Capacity of the Streams.
2. Permissible limits of the Pollutants in the water bodies.
3. Technical advantages if any in mixing the industrial wastes with domestic sewage.

Characteristics of the Industrial Wastes:

The following materials can cause pollution:

Inorganic salts: Inorganic salts, which are present in most industrial wastes as well as in nature itself, cause water to be "hard" and make a stream undesirable for industrial, municipal and agricultural usage. Salt laden waters deposit scale on municipal water- distribution pipelines, increasing resistance to flow and lowering the overall capacity of the lines. Another disadvantage is that, under proper environmental conditions, inorganic salts especially nitrogen and phosphorous induce the growth of microscopic plant life (algae) in surface waters

Acids and /or Alkalis : Acids and Alkalis discharged by chemical and other industrial plants make a stream undesirable not only recreational uses such as swimming and boating, but also for propagation of fish and other aquatic life. High concentrations of sulfuric acid, sufficient to lower the pH below 7.0 when free chlorine is present, have been reported to cause eye irritation to swimmers. A low ph may cause corrosion in air conditioning equipment and a ph greater than 9.5 enhances laundering.

Organic matter : Organic Matter exhausts the oxygen resources of rivers and creates unpleasant tastes, odours and general septic conditions. It is generally conceded that the critical range for fish survival is 3to 4 mg/l of D.O certain organic chemicals such as phenols, affect the taste of domestic water supplies.

Suspended solids : Suspended solids settle to the bottom or wash up on the banks and decompose, cause sing odours and depleting oxygen in the river water. Fish often die because of a sudden lowering of the oxygen content of a stream. Visible sludge creates unsightly conditions and destroys the use of a river for recreational purposes. These solids also increase the turbidity of the watercourse.

Floating Solids and liquids: These includes oils, greases, and other materials which float on the surface, they not only make the river unsightly but also obstruct passage of light through the water, retarding the growth of vital plant food.

Some specific objections to oil in streams are that it

- i) interferes with natural reaeration
- ii) is toxic to certain species of fish and aquatic life
- iii) causes trouble in conventional water treatment processes by imparting tastes and odours to water and coating sand filters with a tenacious film.

Heated Water: An increase in water temperature, brought about by discharging wastes such as condenser waters into streams, has various adverse effects. Streams waters which vary in temperature from one hour to the next are difficult to process efficiently in Municipal and industrial water treatment plants, and heated stream water are of decreased value for industrial cooling, indeed are industry may so increase the temperature of a stream that a neighboring industry downstream cannot use the water since there may be less D.O in warm water than in cold, aquatic life suffers and less D.O is available for natural biological degradation of any organic pollution discharged into these warm surface waters. Also bacterial action increases in higher temperatures, resulting in accelerated depletion of the streams oxygen resources.

Colour : Colour is contributed by textile and paper mills, tanneries, slaughterhouses and other industries, is an indicator of pollution. Colour interferes with the transmission of sunlight into the stream and therefore lessens photosynthetic action. Furthermore, municipal and industrial water plants have great difficulty, and scant success in removing colour from raw water.

Toxic chemicals : Both inorganic and organic chemicals, even in extremely low concentrations, may be poisonous to fresh water fish and other smaller aquatic microorganisms. Many of these compounds are not removed by municipal treatment plants and have a cumulative effect on biological systems

Microorganisms : A few industries, such as tanneries and slaughterhouses, some times discharge wastes containing bacteria. These bacteria are of two significant types:

i) bacteria which assist in the degradation of the organic matter as the waste moves down stream. This process may aid in "seeding" a stream and in accelerating the occurrence of oxygen sag in water.

ii) bacteria which are pathogenic, not only to other bacteria but also to humans.

Radio Active Materials : Cumulative damaging effects on living cells.

Foam Producing Matter : Foam producing matter such as is discharged by textile mills, paper and pulp mills and chemical plants, gives an undesirable appearance to the receiving streams. It is an indicator of contamination and is often more objectionable in a stream than lack of oxygen.

Effects On Sewage Treatment Plants :

The Pollution Characteristics of Wastes having readily definable effects on Sewers and Treatment Plants can be Classified as follows:

Bio Chemical Oxygen Demand : It is usually exerted by Dissolved and Colloidal Organic Matter and imposes a load on the Biological units of the Treatment Plant. Oxygen must be provided so that Bacteria can grow and oxidise the organic matter. An Added B.O.D load, caused by an increase in Organic Waste, requires more Bacterial Activity, more oxygen, and greater Biological Unit capacity for its Treatment, which (makes) increases the capital cost and operating cost.

Suspended Solids: Suspended Solids are found in considerable quantity in many Industrial Wastes, such as Paper & Pulp Effluents. Solids removed by settling and separated from the flowing Sewage are called Sludge, which may then undergo an Anaerobic Decomposition known as Digestion and pumped to drying beds or vacuum filters for extraction of additional water. Suspended Solids in Industrial Waste may settle more rapidly or slowly than Sewage Suspended Matter. If Industrial Solids settle faster than those of Municipal Sewage, Sludge should be removed at shorter intervals to prevent excessive build up: a Slow Settling one will require a longer detention period and larger basins and increases the likelihood of sludge Decomposition with accompanying nuisances, during Sewage-Flow Periods. Any Increased demands on the System usually require larger Sludge handling devices and may ultimately necessitate an increase in the Plants capacity, with resulting Higher Capital and Operating Expenses.

Floating and Coloured Materials: Floating Materials and Coloured Matter such as Oil, Grease and Dyes From Textile-Finishing Mills, are disagreeable and visible nuisances. A Modern Treatment Plant will remove normal Grease loads in Primary Settling Tanks, but abnormally high loads of predominantly emulsified Greases from Laundries, Slaughterhouses etc Passing through the Primary Units into the Biological Units will clog Flow Distributing Devices and Air Nozzles.

Volume: A Sewage Plant can handle any Volume of Flow if its units are sufficiently large. The Hydraulic Capacity of all Units must be analysed, Sewer Lines must be examined for Carrying Capacity, and all other Treatment Units are to be Designed for excessive loading

Harmful Constituents: Toxic Metals, Acids, or Alkalis, Pieces of Fat, Flammable Substances, Detergents and Phenols etc. cause nuisance in Treatment Plants.

Unit II

Waste Reduction Alternatives

Volume Reduction

Introduction

In general, the first step in minimizing the effects of Industrial Wastes on receiving Streams and Treatment Plants is to reduce the Volume of such Wastes.

This may be accomplished by:

1. Classification of wastes
2. Conservation of waste water
3. Changing production to decrease wastes
4. Re-using both industrial and municipal effluents as raw water supplies
5. Elimination of batch or slug discharges of process wastes.

Classification of Wastes:

If wastes are classified, so that manufacturing-process waters are separated from cooling waters, the volume of water requiring intensive treatment may be reduced considerably.

Sometimes it is possible to classify and separate the process waters themselves, so that only the most polluted ones are treated and the relatively uncontaminated are discharged without Treatment.

The Three main classes of waste are:

1. Wastes from manufacturing processes
2. Waters used as cooling agents in industrial processes
3. Wastes from sanitary uses.

Conservation Of wastewater:

Water conserved is waste saved. Conservation begins when an industry changes from open to a closed system. Introduction of conservation practices requires a complete engineering survey of existing water use and an inventory of all plant operations using water and producing wastes, so as to develop an accurate balance for peak and average operating conditions. For example steel mills reuse cooling waters to coal processors reuse water to remove dirt and other non-combustible materials from coal.

Changing Production to Decrease Wastes:

This is an effective method of controlling the volume of wastes but is difficult to put into the practice. It is hard to persuade production men to change their operations just to eliminate wastes. Normally, the operational phase of engineering is planned by the chemical, mechanical or industrial engineer, whose primary objective is cost savings, several measures that can be used to reduce wastes, improved process control, improved equipment design, use of different or better quality raw materials, good house keeping and preventive maintenance.

Re-Using Both Industrial and Municipal Effluents for Raw Water supplies:

Practiced mainly in areas where water is scarce and/or expensive, this is proving a popular and economical method of conservation: of all the sources of water available to Industry, Sewage plant effluent is the most reliable at all seasons of the year and the only one that is actually increasing in quantity and improving in quality.

Many industries and cities hesitate to reuse effluents for raw water supply. Certain technical problems such as hardness, colour and an esthetic reluctance to accept effluents as a potential source of water for any purpose. Also treatment plants are subject to shutdown and sudden discharges, both of which may make the supply undependable or of variable quality. However, as the cost of importing a raw water supply increase, it would seem logical to re-use Waste-treatment plant effluents to increase the present water supply by replenishing the ground water. The ever-available treatment plant effluent can produce a low cost steady water source through ground water recharge. Re-use of sewage effluent will reduce the quantity of pollution discharged by the municipality.

Elimination of Batch or Slug Discharge Of Process Wastes

If the waste is discharged in a short period of time, it is usually referred to as a slug discharge. This type of waste, because of its concentrated contaminants and/or surge in volume, can be troublesome to both treatment plants and receiving streams.

There are atleast two methods of reducing the effects of these discharges:

1. The-manufacturing firm alters its practice so as to increase the frequency and lessen the magnitude of Batch discharges.
2. Slug Wastes are retained in holding basins from which they are allowed to Flow continuously and uniformly over an extended (usually 24-hour) period.

Strength Reduction:

Introduction

Waste Strength reduction is the second major objective for an industrial plant concerned with waste treatment. The strength of wastes may be reduced by:

- 1.Process Changes
- 2.Equipment Modifications
- 3.Segregation of Wastes
- 4.Equalization of Wastes
- 5.By-Product Recovery
- 6.Proportioning of Wastes and
- 7.Monitoring Waste Streams

Process Changes:

In reducing the strength of wastes through process changes, the sanitary engineer is concerned with wastes that are most troublesome from a pollution standpoint.

Equipment Modification:

Changes in equipment can effect a reduction in the strength of the waste, usually by reducing the amounts of contaminants entering the waste stream. An outstanding example of waste strength reduction occurred in the dairy industry. The new cans were constructed with smooth necks so that they could be drained faster and more completely. This prevented a large amount of milk waste from entering streams and sewage plants.

Segregation of Wastes:

Segregation of Wastes reduces the strength and/or the difficulty of treating the final waste from an industrial plant. It usually results in two wastes: one strong and small in volume and the other weaker with almost the same volume as the original unsegregated waste. The small- volume strong waste can then be handled with methods specific to the problem it presents. In terms of volume reduction alone, segregation of cooling waters and storm waters from process waste will mean a saving in the size of the final treatment plant.

Equalization of Wastes:

Plants, which have many products, from a diversity of processes, prefer to equalize their wastes. This requires holding wastes for a certain period of time, depending on the time taken for the repetitive process in the plant. For example, if a manufactured item requires a series of operations that take eight hours, the plant needs an equalization basin designed to hold the wastes for that eight hours period. The effluent from an equalization basin is much more consistent in its characteristics than each separate influent to that same basin.

Stabilization of pH and B.O.D and settling of Solids and Heavy Metals are among the objectives of equalization. Stable effluents are treated more easily and efficiently, than unstable ones by industrial and municipal treatment plants.

By-Product Recovery:

All wastes contain by products, the exhausted materials used in the process. Since some wastes are very difficult to treat at low cost, it is advisable for the Industrial Management concerned to consider the possibility of building a recovery plant which will produce a Marketable By-Product and at the same time solve a trouble some Wastes problem.

Proportioning Wastes:

By Proportioning its discharge of concentrated wastes into the main sewer a plant can often reduce the strength of its total waste to the point where it will need a minimum of final treatment or will cause the least damage to the stream or treatment plant.

It may prove less costly to proportion one small but concentrated waste into the main flow. According to the rate of the main flow, than to equalize the entire waste of the plant in order to reduce the strength.

Monitoring Waste Streams:

Accidental spills are often the sole cause of stream pollution or malfunctioning of treatment plants and these can be controlled, and often eliminated completely, if all significant sources of wastes are monitored.

Neutralization

Introduction

Excessively acidic or alkaline wastes should not be discharged without treatment into a receiving stream. A stream is adversely affected by low or high pH values. This adverse condition is even more critical when sudden sludge of acids or alkalis are imposed upon the stream.

Acceptable Methods of Neutralization:

1. Mixing wastes so that the net effect is a neutral pH.
2. Passing acid wastes through beds of limestone.
3. Mixing acid wastes with lime slurries.
4. Adding the proper proportions of concentrated solutions of caustic soda(NaOH) or soda ash (Na_2CO_3)to acid wastes.
5. Adding compressed CO_2 to alkaline wastes.
6. Adding sulfuric acid to alkaline wastes.

The material and method used should be selected on the basis of the overall cost, since material costs vary widely and equipment for utilizing various agents will differ with the method selected. The volume, kind and quality of acid or alkali to be neutralized are also factors in deciding which neutralizing agent to use. .

Equalization:

Equalization is a method of retaining wastes in a basin so that the effluent discharged is fairly uniform in its characteristics (pH, colour ,turbidity ,alkalinity , B.O.D etc). A secondary but significant effect is that of lowering the concentration of effluent contaminants. A retention pond serves to level out the effects of peak loadings on the plant while substantially lowering the B.O.D and suspended solids load to the aeration unit.

Air is sometimes injected into these basins to provide:

1. Better mixing
2. Chemical oxidation of reduced compounds
3. Some degree of biological oxidation
4. Agitation to prevent suspended solids from settling.

The size and shape of the basins vary with the quantity of waste and the pattern of its discharge from the industry. The capacity should be adequate to hold and render homogeneous, all the wastes from the plant. Almost all industrial plants operate on a cycle basis; thus if the cycle of operations is repeated for every two hours, an equalization tank which can hold a two -hour flow will usually be sufficient.

The mere holding of waste, however is not sufficient to equalizing it. Each unit volume of waste discharged must be adequately mixed with other unit volumes of waste discharged many hours previously.

This mixing may be brought about in the following ways:

1. Proper distribution and baffling
2. Mechanical agitation
3. Aeration and
4. Combination of all three.

Proportioning

Proportioning means the discharge of industrial wastes in proportion to the flow of municipal sewage in the sewers or to the stream flow in the receiving river. In most case it is possible to combine equalization and proportion in the same basin. The effluent from the equalization basin is metered into the sewer or stream according to a predetermined schedule. The objective of proportioning in sewers is to keep

constant the percentage of industrial wastes to domestic sewage flow entering the municipal sewage plant.

This procedure has several purposes:

1. To protect municipal sewage treatment using chemicals from being impaired by a sudden overdose of chemicals contained in the industrial waste.
2. To protect biological treatment devices from strong loads of industrial wastes, which may inactivate the bacteria.
3. To minimize fluctuations of sanitary standards in the treated effluent.

The rate of flow of industrial waste varies from instant to instant, as does the flow of domestic sewage system. Therefore the industrial waste must be equalized and retained, then proportioned to the sewer or stream according to the volume of domestic sewage or stream flow.

Treatment and Disposal of Sludge Solids

Introduction

Of prime importance in the treatment of all liquid wastes is the removal of solids both suspended and dissolved. Once these solids are removed from the liquids, however their disposal becomes a major problem.

The following list contains most of the methods commonly used to deal with sludge solids.

1. Anaerobic and Aerobic digestion
2. Vacuum filtration
3. Drying beds
4. Sludge lagooning
5. Drying and incineration
6. Centrifuging
7. Landfill

Anaerobic and Aerobic digestion:

Anaerobic digestion is a common method of readying sludge solids for final disposal. All solids settled out in primary, secondary or other basins are pumped to an enclosed air tight digester, where they decompose in an anaerobic environment. The rate of their decomposition depends primarily on proper seeding, ph, character of the solids, temperature etc. digestion serves the dual purpose of rendering the sludge solids readily drainable and converting a portion of the organic matter to gaseous end products. It may reduce the volume of sludge by as much as 50% organic

matter reduction. After digestion, the sludge is dried and /or burned or used for fertilizer or landfill.

Two main group of microorganisms hydrolyte and methane, carry out digestion. Fermentation (digestion) of organic matter proceeds in two stages:

1. Hydrolytic action, converting organic matter to low molecular weight organic acids and alcohols and
2. Evolution of carbon dioxide and the simultaneous reduction to methane(CO_2 is actually consumed).

The proper environment for both types of bacteria requires a balance between population of organisms, food supply, temperature, ph, and food accessibility. The following factors are measures of the effectiveness of digestive action : gas production, solids balance, B.O.D, acidity and ph, sludge characteristics and odours.

The usual unit capacity requirements may be reduced, provided the operations are controlled and carried out as follows:

1. Tank contents must be agitated to maintain an even mixture of raw and digesting solids
2. Raw sludge must be added continuously to the digest in unit
3. Raw sludge must be concentrated before being added to the digester. Two stage digestion, with the first stage used primarily for active digestion and the second stage for storage and sludge consolidation is often carried out in two separate tanks.

Vacuum filtration:

Vacuum filtration is a means of dewatering sludge solids. In a typical vacuum filtration unit, a porous cylinder overlying a series of cells revolves about its axis with a peripheral speed somewhat less than one foot per minute, its lower portion passing through a trough containing the sludge to be dried. A vacuum inside the cylinder picks up a layer of sludge as the filter surface passes through the trough, and this increases the vacuum. When the cylinder has completed three quarters of revolution a slight air pressure is produced on the appropriate cells, which aids the scraper or strings to dislodge the sludge in a thin layer.

Drying beds :

Sludge drying beds remove moisture from sludge, thereby decreasing its volume and changing its physico-chemical characteristics, so that sludge containing 25% solids can be moved with a shovel or

garden fork and transported in watertight containers. Sludge filter beds are made up of 12 to 24 inches of coarse sand, well seasoned (), or even washed grit from grit chambers and about 12 inches coarse gravel beneath the sand. The upper 3 inches of gravel particles are 1/8th to 1/4th inch diameter. Below the gravel, the earth floor of the bed is pitched to a slight grade into open joint tile under drains 6 or 8 inches in diameter

Sludge Lagooning :

Lagoons may be defined as natural or artificial earth basins used to receive sludge.

There are many factors to be considered:

1. Nature and topography of the disposal area
2. Proximity of the site to populated areas
3. Soil condition

Chemical composition of sludges with special considerations given to toxicity and odour producing constituents.

Removal of Organic Dissolved Solid

Introduction

The removal of dissolved organic matter from waste water is one of the most important tasks. These solids are usually oxidized rapidly by microorganisms in the receiving streams, resulting in loss of dissolved oxygen and the accompanying ill effects of deoxygenated water. They are difficult to remove because of the extensive detention time required in biological processes. In general, biological methods have proved most effective for this phase of waste treatment, and the greater the bacterial efficiency the greater the reduction of dissolved organic matter.

There are many varieties of biological treatment, each adapted to certain types of waste waters and local environment conditions. Some specific processes for treating organic matter are:

1. Lagooning in oxidation ponds
2. Activated sludge process
3. Contact stabilization
4. Trickling filtration
5. Anaerobic digestion
6. Mechanical aeration
7. Sub surface disposal

Lagooning:

Lagooning in oxidation ponds is a common means of both removing and oxidizing organic matter and waste waters as well. Stabilization or oxidation of waste in ponds is the result of several natural self purification phenomena. The first phase is sedimentation- settleable solids are deposited in an area around the inlets to the ponds, some suspended and colloidal matter is precipitated by the action of soluble salts, decomposition of the resulting sediment by microorganisms changes the sludge into inert residues and soluble organic substances, which intern are required by other micro-organisms and algae for their metabolic processes. .

Its Origin, Character and Treatment :

Sno.	Industries producing wastes	Origin of major wastes	Major characteristics	Major Treatment and Disposal methods
1.	Tannery	Unhairing, Soaking, Delining, Bating of hides	High total solids,Hardness,Salt, Sulfides,chromium, pH, B.O.D and Precipitated lime	Equalization, Sedimentation, Biological treatment
2.	Textiles	Cooking of fibres, desizing of fabric.	Highly alkaline,coloured, high B.O.D,High Suspended solids and Temperature.	Neutralization,chemical precipitation, Biological Treatment,Aeration and /or trickling filter.
3.	Dairy	Dilution of Milk,Separated milk, buttermilk.	High in Dissolved Organic matter mainly protein, Fat and lactose	Biological Treatment,Aeration,Trickling-Filters and Activated sludge process.
4.	Distilleries	Steeping and Pressing of Grain,residue from Distilleries of alcohol, Condensate from Stillage Evaporation.	High in dissolvedOrganic solids, Containing Nitrogen and Fermented Starches.	Recovery,Concentration By Centrifugation and Evaporation, Trickling filterUse in feeds.
5.	Meat	Stockyards,Slaughtering of Animals, Rendering of Bones and fats,Residues in condensates,Grease and Wash water,Pickling of	High in dissolved and suspended organic matter, blood other Proteins and fats.	Screening,settling and/or floatation,Trickling filter.

		Chickens.		
6.	Beet sugar	Transfer, screening, juicing waters, drainage from lime sludge, Condensates. After evaporation, juice and extracted sugar.	High in dissolved suspended organic matter, containing sugar and protein.	Re- use of wastes, coagulation, Lagooning.
7.	Rice	Soaking, cooking and washing of rice.	High B.O.D, Total and suspended Solids (mainly Starch)	Lime coagulation digestion.
8.	Cane sugar	Spillage from extraction, clarification evaporation entrainment in cooling and condensed waters.	Variable pH Soluble organic matter with high B.O.D of carbonaceous nature.	Neutralization, Recirculation, chemical treatment, Aerobic oxidation.
9.	Paper and pulp	Cooking, Refining, washing of Fibres Screening of paper pulp.	High or low pH, colour, high suspended, Colloidal and dissolved solids inorganic filters.	Settling, Lagooning, Biological treatment, Aeration, Recovery of by products.
10.	Steel	Coking of coal, Washing of blast furnace flue gases and pickling of steel.	Low pH, acids, phenol, ore, coke, limestone, alkali, oils, Fine suspended solids.	Neutralization, recovery and reuse, chemical coagulation.
11.	Metal plating	Stripping of oxides, cleaning and plating of metals.	Acid, metals, Toxic low volume mainly mineral water.	Alkaline chlorination of cyanide, reduction and precipitation of chromium, Lime precipitation of other metals.
12.	Petroleum refineries	Drilling mud, salt, oil and some natural gas, Acid sludge's and miscellaneous oils from refining.	High suspended solids (sand, clay), high dissolved solids, high B.O.D, odour, phenol & sulfur Compounds from refinery.	Selective screening, Drying of reclaimed sand, diversion, recovery, injection of salts, Acidification and burning of alkaline sludge.
13.	Atomic energy plants	Processing ores, laundering of contaminated clothes, Research Lab wastes, Processing of fuel, power plant cooling water.	Radioactive elements can be very acidic and hot.	Concentration and containing or dilution and dispersion.
14.	Fertilizer	Chemical reactions of basic elements, Spills,	Sulfuric, phosphorous and nitric acids,	Neutralization, detaining for Re-use, sedimentation, Air stripping of NH ₃ ,

		cooling waters, wasting of products, boiler blowdowns.	mineral elements, P,S, N, K, AL,NH ₃ , NO ₃ ,FL etc and some suspended solids.	lime precipitation.
--	--	--	--	---------------------

Phosphorus Removal

Introduction

Controlling phosphorous discharged from municipal and industrial wastewater treatment plants is a key factor in preventing eutrophication of surface waters. Phosphorous is one of the major nutrients contributing in the increased eutrophication of lakes and natural waters.

Its presence causes many water quality problems including increased purification costs, decreased recreational and conservation value of an impoundments, loss of livestock and the possible lethal effect of algal toxins on drinking water.

Phosphate removal is currently achieved largely by chemical precipitation, which is expensive and causes an increase of sludge volume by up to 40%.

An alternative is the biological phosphate removal

Phosphorous in wastewater

Municipal wastewaters may contain from 5 to 20 mg/l of total phosphorous, of which 1-5 mg/l is organic and the rest in inorganic.

The individual contribution tend to increase, because phosphorous is one of the main constituent of synthetic detergents.

The individual phosphorous contribution varies between 0.65 and 4.80 g/inhabitant per day with an average of about 2.18 g.

The usual forms of phosphorous found in aqueous solutions include:

Orthophosphates: available for biological metabolism without further breakdown

Polyphosphates: molecules with 2 or more phosphorous atoms, oxygen and in some cases hydrogen atoms combine in a complex molecule.

Usually polyphosphates undergo hydrolysis and revert to the orthophosphate forms.

This process is usually quite slow.

Normally secondary treatment can only remove 1-2 mg/l, so a large excess of phosphorous is discharged in the final effluent, causing eutrophication in surface waters.

New legislation requires a maximum concentration of P discharges into sensitive water of 2 mg/l.

Phosphorous removal processes

Treatment technologies presently available for phosphorus removal include:

Physical: filtration for particulate phosphorus membrane technologies

Chemical: precipitation

other (mainly physical-chemical adsorption) Biological assimilation

Enhanced biological phosphorus removal (EBPR)

The greatest interest and most recent progress has been made in EBPR, which has the potential to remove P down to very low levels at relatively lower costs.

Membrane technologies are also receiving increased attention, although their use for P removal has been more limited to date.

The question of sludge handling and treatment of P in side streams is also being addressed.

Physical Treatment

Filtration for particulate Phosphorous

Assuming that 2-3% of organic solids is P, then an effluent total suspended solids (TSS) of 20 mg/L represents 0.4-0.6 mg/L of effluent P .

In plants with EBPR the P content is even higher.

Thus sand filtration or other method of TSS removal (e.g., membrane, chemical precipitation) is likely necessary for plants with low effluent TP permits

Membrane technologies

Membrane technologies have been of growing interest for wastewater treatment in general, and most recently, for P removal in particular.

In addition to removing the P in the TSS, membranes also can remove dissolved P.

Membrane bioreactors (MBRs, which incorporate membrane technology in a suspended growth secondary treatment process), tertiary membrane filtration (after secondary treatment), and reverse osmosis (RO) systems have all been used in full-scale plants with good results.

Chemical Treatment

Precipitation

Chemical precipitation has long been used for P removal. The chemicals most often employed are compounds of calcium, aluminum, and iron .

Chemical addition points include prior to primary settling, during secondary treatment, or as part of a tertiary treatment process

However, that the process is more complex than predicted by laboratory pure chemical experiments, and that formation of and sorption to carbonates or hydroxides are important factors.

Gas concrete (produced from mixtures of silica, sand, cement, lime, water, and aluminum cake) waste was used to remove phosphate from pure aqueous solutions .

High phosphate removal (> 95% in 10 min, batch system) was obtained from a 33 mg/L P solution, but direct applicability to wastewater treatment (lower concentrations, possible interferences) was not investigated.

The gas concrete's removal efficiency can be regenerated at low pH, with the resulting concentrated phosphate solution potentially a source of recycled phosphate.

Similarly, iron oxide tailings were found to be effective for phosphorus removal from both pure solutions and liquid hog manure

Biological Treatment

Assimilation

Phosphorus removal from wastewater has long been achieved through biological assimilation – incorporation of the P as an essential element in biomass, particularly through growth of photosynthetic organisms (plants, algae, and some bacteria, such as cyanobacteria).

Traditionally, this was achieved through treatment ponds containing planktonic or attached algae, rooted plants, or even floating plants (e.g., water hyacinths, duckweed).

EBPR

As indicated in the introduction, the greatest recent and present interest has been in enhanced biological phosphorus removal.

This is because of its potential to achieve low or even very low (<0.1 mg/L) effluent P levels at modest cost and with minimal additional sludge production.

Removal of traditional carbonaceous contaminants (BOD), nitrogen, and phosphorus can all be achieved in a single system, although it can be challenging to achieve very low concentrations of both total N and P in such systems.

Joint Treatment of Industrial Waste and Domestic Sewage

Industrial discharges often significantly alter the total flow and concentrations of various wastewater constituents, such as biochemical oxygen demand (BOD), suspended solids, and heavy metals, to be treated by municipal treatment facilities.

These factors are important in determining the size and type of treatment processes required to meet the increasingly stringent standards being imposed on communities.

Planning for the joint treatment of domestic and industrial wastewater is a crucial element in the design of cost-effective treatment systems.

The impact of joint treatment on the various participants and their corresponding responses will be important in determining the type and size of facilities required.

Advantages

The municipality is required to provide joint treatment when certain conditions are met, but it has considerable flexibility in making use of such policy instruments as pricing strategies and pretreatment requirements to encourage or discourage joint treatment.

The municipality will compare the additional benefits and costs of joint treatment in order to determine its policies.

EPA describes several benefits a municipality may anticipate from joint treatment.

One such benefit is the potential economies of size associated with small-scale treatment facilities which serve rural communities.

The increased flow from industrial participation is expected to result in lower average treatment costs.

The increased flow may also result in a reduced peak-to-average flow ratio, thereby increasing capacity utilization.

Treatment of combined wastes also allows the use of nutrients available in domestic wastes for biological treatment of industrial wastes that may be nutrient deficient.

Disadvantages

Inclusion of industrial wastes in municipal wastewater treatment systems can, however, lead to additional system costs.

Many industrial wastewaters, while compatible with common treatment processes, are more highly concentrated, in terms of constituents such as BOD and suspended solids, than normal domestic sewage.

The inclusion of these wastes, therefore, may require longer detention times and/or equipment with larger capacities, resulting in higher per unit treatment costs.

Industrial wastes often contain high levels of pollutants, such as heavy metals, grease, cyanide, and many organic compounds, which are incompatible with certain biological treatment technologies.

The efficiency of biological processes may be lowered with the presence of certain pollutants, thereby creating the potential for increased pass-through of pollutants and possible violation of the municipality's National Pollutant Discharge Elimination System (NPDES) permit for direct discharge.

Sufficient levels of some pollutants may even cause a complete breakdown.

To prevent such a breakdown, the treatment facility may have to substitute higher cost treatment alternatives or require additional treatment processes not otherwise necessary for treatment of the municipal wastes, and therefore, not subject to Federal subsidies.

In addition, industrial pollutants are likely to become concentrated in the wastewater sludges.

This may lower the quality of resultant sludges, making them unsuitable for certain disposal methods and possibly increasing disposal costs.

Finally, incompatible wastes from industrial sources may simply pass through the treatment plant without affecting its operations and associated costs, but may cause the plant to violate its NPDES permit with respect to the corresponding pollutants.

WASTE WATER DISPOSAL METHODS

- **Introduction**

- The disposal of sewage effluent is the last stage of getting rid of sewage after subjecting it to various steps of processes (i.e.) treatment of transforming the sewage into the harmless liquid which fulfils the minimum standard of health and sanitation.
- The main object of controlling disposal of sewage are
 - To render the sewage inoffensive
 - To save the aquatic life in streams
 - To eliminate the danger of contamination of water supplies.
- The amount or degree of treatment that should be given to the sewage depends upon the source of its disposal as well as its capacity to assimilate the impurities present in the sewage without itself getting polluted or less useful.
- So before designing the treatment plant first the source of disposal has to be selected.

Methods of Wastewater Disposal

- Natural Methods
- Artificial Methods
- Combined Methods
- Natural Methods
 - (i) Dilution or disposal into water i.e. into sea, lakes or rivers
 - (ii) Disposal on land or land treatment i.e. sewage farming and irrigation.

- Artificial Methods
- Artificial method is by which the sewage is disposed off only after subjecting it to various treatments (primary and secondary) such as:
 - Screening and detritus removal
 - Sedimentation with or without chemicals
 - Biological treatment (trickling filter, oxidation pond or activated sludge process)

Now a days the actual practice is to use both the methods, the sewage is first given the treatment and then it is disposed off by any of the natural method. If full treatment is not given at least the primary treatment is given before disposal.

Dilution

- Dilution is a prominent method of natural disposal, consists of discharging the wastewater into receiving water body (Such as river, sea, lake etc.)
- This is done on the assumption that the sufficient dissolved oxygen is available in the water body so that biochemical oxygen demand is satisfied.
- If however, the diluting water is not sufficient to supply the biological(or biochemical) oxygen demand to oxidise the entire matter present, there will be nuisance of foul odour and unsightly islands of half digested floating, putrefying matter at the surface.
- In addition to this problem, the depletion of oxygen would kill the aquatic life, and if this dilution water is used at the downstream side for drinking purpose, it will cause danger to the public health.
- The discharged wastewater or effluent is purified, in due course of time, by the so called self purification process of natural streams.
- The limit of effluent discharge and the degree of treatment of wastewater depend upon the self purification capacity of natural waters as well as the intended use of the water body at the downstream side.

Conditions Favoring Disposal

- The Dilution method for disposing of the sewage can favorable by adopted under the following conditions:
 - When the sewage is comparatively fresh i.e. it is discharged within 3-4 hours of its collection.
 - When the floating matter and settleable solids have been removed by primary treatment.
 - When the diluting water has high DO content, so that not only the BOD is satisfied, but sufficient DO remains available for the aquatic life.

- Where the dilution waters are not used for the purpose of navigation or water supply for at-least some reasonable distance on the downstream from the point of sewage disposal.
- Where flow current of the diluting waters are favorable, causing no deposition or destruction to aquatic life. Its means that swift forward currents are helpful, as they easily carry away the sewage to the point of unlimited dilution. On the other hand, slow back currents tend to cause sedimentation, resulting in large sludge deposits.
- Where the wastewater does not contain industrial wastewater having toxic substances.
- When the outfall sewer of the city or the treatment plant is situated near some natural waters.

Standards Of Dilution For Discharge Of Wastewater Into Rivers

- The ratio of the quantity of the diluting water to that of sewage is known as the diluting factor; and depending upon this factors the ‘ Royal Commission Report of Sewage Disposal’ has laid down the following standards and degree of treatment required to be given to a particular sewage.
 - The above mentioned standards have been operative in England since 1912, and had also been following in India without much change.
1. But with the increase in the pollution by indiscriminating disposal of domestic as well as industrial waste into rivers without the considerations of various pollutants being discharge in the surface water.
 2. For this purpose countries have prescribed their own standards including India.
- The bureau of Indian standards has therefore laid down its guiding standards for sewage effluents, vide 4764-1973 and for industrial effluents vide IS 2490 – 1974
 - These standards are the national guide lines for each state pollution control board, using which they prescribed their legally enforceable standards depending upon the water quality and dilution available in their respective surface water sources.
 - When the industrial waste water are disposed of in to public sewers, their quality should be control by using the standards IS 3306-1974

Types Of Receiving Waters For Dilution

The following are the types of receiving waters into which wastewater or effluent can be discharged for dilution:

- Perennial rivers and streams
- Lakes
- Oceans or Sea
- Estuaries

Creeks

- Perennial rivers and streams
- Perennial rivers or streams are probably the best type of receiving waters, since the water is in continuous motion.
- Also in the natural streams there is balance between plant and animal life, with considerable interaction among the various life forms.
- However the discharge flowing during summer and during winter varies.
- During summer, there may be minimum flow in the stream, so the dilution factor may be low, and also high temperature of water may result in low solubility of oxygen, necessitating proper treatment before dilution

Lakes

- Sometimes, especially when the perennial streams are not available lakes may be used for dilution.
- Various characteristics of lakes, such as its size, shape, volume of fresh water flowing into it etc.. should be critically examined before deciding the self purifying capacity.

Ocean

Ocean has abundant water so that the dilution factor is unlimited. However, sea water has about 20 % less DO than river or stream.

The water is turbid due to dissolved impurities and penetration of sun rays is less.

Due to this proper care has to be taken in dilution by sea otherwise anaerobic conditions would occur resulting in forming of sludge banks and emission of foul odour.

Creek

- A creek is in the form of an inlet on sea coast, which may not have dry weather flow during some part of the year.
- Due to this, great care should be taken in disposal of effluent in to it.
- Estuary
- Estuary is wide lower tidal part of the river.
- Hence dilution in an estuary is affected both by ocean water as well as river water.
- However, the process of dilution is generally satisfactory in estuaries.
- Introduction

- When the wastewater or the effluent is discharged into a natural stream, the organic matter is broken down by bacteria to ammonia, nitrates, sulphates, carbon dioxide etc.
- In this process of oxidation, the dissolved oxygen content of natural water is utilized. Due to this, deficiency of dissolved oxygen is created.
- As the excess organic matter is stabilized, the normal cycle will be reestablished in a process known as self purification where in the oxygen is replenished by its aeration by wind.
- Actions involved in Self-purification
- Dilution
- Dispersion due to currents
- Sedimentation
- Oxidation
- Reduction
- Temperature
- Sun light
- Dilution
- When wastewater is discharged into the receiving water, dilution takes place due to which the concentration of organic matter is reduced and the potential nuisance of sewage is also reduced.
- If C_s and C_r are the concentrations of any impurity such as organic content, BOD, Suspended solids in the sewage and the river having discharge rates Q_s and Q_r respectively, the resulting concentration 'C' of the mixture is given by

$$C = \frac{C_s Q_s + C_r Q_r}{Q_s + Q_r}$$

- When the dilution ratio is quite high, large quantities of DO are always available which will reduce the chances of putrefaction and pollutional effects.

Dispersion due to currents

- Self purification of stream largely depends upon currents which will readily disperse the wastewater in the stream, preventing locally high concentration of pollutants.
- High velocity improves re aeration which reduces the time of recovery, though length of stream affected by the wastewater is increased.

Sedimentation

- If the stream velocity is lesser than the scour velocity of particles, sedimentation will take place, which will have two effects:
- The suspended solids, which contribute largely to oxygen demand will be removed by settling and hence water quality to downstream will be increased.
- Due to settled solids anaerobic decomposition may take place.

Oxidation

- The organic matter, present in the wastewater is oxidised by aerobic bacteria utilising dissolved oxygen of the natural water.
- The process prevails till complete oxidation of organic matter takes place.
- The stream which is capable of absorbing more oxygen rapidly through re aeration etc. can purify heavily polluted water in a short time.

Reduction

- The reduction occurs in the streams due to hydrolysis of the organic matter biologically or chemically.
- Anaerobic bacteria will split the organic matter into liquids and gases, thus paving way for their ultimate stabilization by oxidation.

Temperature

- At low temperatures, the activities of bacteria is low and hence rate of decomposition will also be slow, though DO will be more because of increased solubility of oxygen in water.
- At higher temperatures, however, the self-purification takes lesser time, though the quantity of DO will be less.

Sun Light

- Sun light helps certain microorganisms to absorb carbon dioxide and give out oxygen, thus assisting in self purification.
- Sun light acts as a disinfectant and stimulates the growth of algae which produce oxygen during day light but utilise oxygen at night.
- Hence whenever there is algal growth, the water may be supersaturated with DO during day light hours, through anaerobic conditions exist in night.

Zones of pollution in streams

- Zone of degradation

- Zone of active decomposition
- Zone of recovery
- Zone of clear water
- Zone of degradation
- This zone is situated just below the outfall sewer when discharging its contents into the stream.
- The DO is reduced to 40% of the saturation values.
- There is an increase in CO₂ content, and reaeration is much slower than deoxygenation.
- Though conditions are unfavourable for aquatic life, fungi at higher points and bacteria at lower points breed small worms which work over and stabilise sewage sludge.
- The decomposition of solid matter takes place in this and anaerobic decomposition prevails.

Zone of active decomposition

- This zone is just after the degradation zone and is marked by heavy pollution.
- Water in this zone becomes grayish and darker than the previous zone.
- The DO concentration in this zone falls down to zero.
- Active anaerobic decomposition takes place with the evolution of methane, hydrogen sulphide, carbon dioxide and nitrogen.
- Protozoa and fungi first disappear and then reappear, while algae will mostly be absent.
- Near the end of this zone, as the decomposition slackens, reaeration sets in and DO again rises to its original level of 40%.

Zone of recovery

- In this zone the process of recovery starts, from its degraded condition to its former condition.
- The stabilization of organic matter takes place in this zone.
- Due to this most of the stabilised organic matter settles as sludge, BOD falls and DO content rises above the 40% value.
- Mineralisation is active, with the resulting formation of products like nitrates, sulphates and carbonates.
- Near the end of this zone, microscopic aquatic life reappears, fungi decrease and algae reappears.

Zone of clear water

- In this zone the natural condition of stream is restored with the result that (i) water becomes clear and attractive in appearance. (ii) DO rises to the saturation level and is much higher than the BOD and (iii) Oxygen balance is attained.
- The recovery is said to be complete in this zone, though some pathogenic organisms present in this zone.

Disposal of Wastewaters in Lake

- Water quality management is entirely different from that in rivers.
- River is a flowing water body while lake has stagnant waters, so in lakes only top surface would become saturated with DO, but the bottom layers would not have enough oxygen.
- Overturning of layers would not occur frequently, so that DO content would not be uniform through out the depth of lake.
- Overturning takes place only when there is change in the season due to which there will be temperature difference between water in different layers which cause change in the densities of different layers and overturning occurs.

Lake Pollutants

- In Lake the phosphorous a nutrient largely contained in industrial domestic wastewater is seriously affecting the quality of lakes and hence it is considered as the prime lake pollutant.
- Oxygen demanding wastes may be the other important lake pollutant.
- The toxic chemicals from industrial wastewater can be present.

Eutrophication

- Phosphorous acts as the nutrients for the algal growth.
- Increase in the phosphorous content would increase the algal growth.
- Excessive in the phosphorous content would increase the algal growth.
- Excessive algal growth (Algal Bloom) will create lot of the problems like taste, odour, problems in oxygen diffusion in lower layer.
- Ultimately the entire lake can get covered with algae and it may become useless for other organisms

Disposal of Wastewater in Sea or Ocean

- The saturation concentration of dissolved oxygen in water decreases with increasing salt concentration.
- DO in sea water is approximately 80 % of that in water.

- In addition to this deficiency, the temperature of sea water is lower than the sewage temperature, whereas the specific gravity is higher.
- Due to this deficiency, the temperature, whereas the specific gravity is higher.
- Due to this reasons, when the sewage is discharged into the sea water, the lighter and warmer sewage will rise up to the surface, resulting in lighter and warmer sewage will rise up to the surface, resulting in spreading of the sewage at the top surface of sea in a thin film or 'sleek'
- Moreover seawater contains a large amount of dissolved matter which chemically reacts with the sewage solids, resulting in the precipitation of some of the sewage solids, giving a milky appearance to the sea water and resulting in formation of sludge banks and thin milky layer formed at the top of sea water produce offensive hydrogen sulphide gas by reacting with sulphate rich sea water.
- As such the capacity of seawater to absorb sewage solids is not as high as that of fresh water of a river.
- Also the DO content is less. However, since the sea contains large volume of water, most of these deficiencies can be overcome if the sewage is discharged deep into the sea, much away from the coast line, with extreme care.
- Points be kept in mind while discharging sewage into the sea
- The sewage should be discharged in deep sea water.
- In order to mix sewage properly with the seawater, the sewage should be released at a minimum depth of 3 to 5 m below the water level and taking it sufficiently inside the shore, and thus preventing nuisance to baths and recreation centres on the shore.
- To prevent the backing up and spreading of sewage on the sea shore, the sewage should be disposed of only during low tides, large sized tanks may, therefore be constructed to hold the sewage during high tides. Provision of a large sized sewer, grated with non return valve at the end, is also an alternative to hold the sewage during high tides.

Before deciding the position of the outfall point, the sea current, wind directions, velocity, etc., should be properly studied. The sea currents, wind direction, velocity, etc.. should be properly studied. The point of disposal should be such that the sewage is taken away from the shore by the winds, and not brought back near the shore by the winds, and not brought back near the shore.

The outfall sewer should be placed on a firm rocky foundation, and encased in thick stone masonry, so as to properly protect it from wave action, floating debris, etc..

The discharge of Industrial waste waters into sea should however, be controlled in respect of the quality of the effluents, by adhering to the following Indian standards., prescribed by IS 1968-1976.

Disposal of Sewage on land

- In this method, the sewage effluent either treated or raw is disposed of by applying it on land.
 - The most common forms of land application are irrigation (Sewage farming) and rapid infiltration.
 - When raw or partly treated sewage is applied on the land, a part of it evaporates and remaining portion percolates in the soil.
 - If proper voids are maintained in the soil, the organic sewage solids are oxidized by the bacteria present in the soil under aerobic condition.
 - However, if the soil is made of heavy, sticky, and fine grained materials, the void space will soon get clogged resulting in non aeration of these voids which would lead to anaerobic condition and subsequent evolution of foul gases.
 - Application of too strong or too hard of sewage will also result in the quick formation of anaerobic conditions. The loads of sewage can be reduced by dilution or pretreatment.
 - Sewage Farming
 - The sewage effluents can be used for irrigating farms exactly in the same manner as irrigation water is used for farming.
 - Wastewater can be applied to land by the following three methods.
- Sprinkler method or spray irrigation
 - Subsurface irrigation
 - Surface irrigation
- (a) Basin Method
 - (b) Flooding method
 - (c) Furrow method
- Out of these spray irrigation is most commonly adopted in western countries, while surface irrigation is commonly adopted in India.
 - For spray irrigation the sewage should be pretreated otherwise the spray nozzles can get clogged.
- In the subsurface irrigation method, wastewater is supplied directly to the root zone of plants through the system of underground pipes with open joints.
 - The method is not suitable for untreated wastewater containing lot of suspended solids

- • In surface method wastewater is applied directly on the farm and depending upon the land preparation and method of application of wastewater there can be different method of surface irrigation.
- Sewage Sickness
 - • When the sewage is applied continuously on a piece of land, the soil pores or voids may get filled up and clogged with sewage matter retained in them.
 - The time taken for such clogging will depend upon the type of the soil and the load present in sewage. But once these voids gets clogged, free circulation of air will be prevented an anaerobic conditions will develop within the pores.
 - Decomposition of organic matter would take place under anaerobic conditions with evolution of foul gases like H₂S, CO₂ and methane. This phenomenon of soil getting clogged, is known as sewage sickness

Methods of Preventing Sewage Sickness

- In Order to prevent the sewage sickness of a land, the following preventive measures may be adopted.
 - Primary Treatment of Sewage: The Sewage should be disposed of, only after primary treatment, such as screening, grit removal, and sedimentation. This will help in removing settleable solids and reducing the BOD load by 30 % or so, and soil pore will not get clogged frequently.
 - Choice of Land: The piece of land used for sewage disposal should normally be sandy or loamy. Clayey lands should be avoided.
 - Under drainage of Soil: The land, on which the sewage is being disposed of, can be drained, if a system of under- drains is laid below, to collect the effluent. This will also minimize the possibilities of sewage sickness
 - Giving rest to the land: The land being used for the disposal should be given rest, periodically by keeping some extra land as reserve and stand-by for diverting the sewage during the rest period, the land should be thoroughly ploughed, so that it gets broken up and aerated.
 - Rotation of Crops: Sewage Sickness can be reduced by planting crops in rotation instead of growing single type of a crop. This will help in utilizing the fertilizing elements of sewage and help in aeration of soil.
 - Applying Shallow depths: The sewage should not be filled over the area in large depths, but it should be applied in thin layers. Greater depth of sewage on a land does not allow the soil to receive the sewage satisfactorily and ultimately results in clogging.
 - • A Sewage sick land can be improved and made useful by thoroughly ploughing and breaking the soil, and exposing it to the atmosphere.

- **Comparison of Disposal Methods**

- For most of Indian towns and cities the land disposal is a better choice because of following reasons:
- India is a tropical country temperature remains high in most part of the year. Due to hot climate, DO content of the river water reduces, while the fish and aquatic life requires higher DO for their survival, thus making the dilution method more difficult and prohibitive.
- Most of the rivers have a very small amount of dry weather flow (in summer) so amount of dilution available would be less. Also in most of the cities these rivers are the only source of drinking water. So disposal by dilution method cannot be used, and if used, a very high degree of treatment is required which would increase the cost of disposal.
- Except for a few major cities, the water supplies in India are very low, thus resulting in the production of highly concentrated sewage, which on travelling in hot climate, becomes stale and septic by the time it reaches the disposal point, thus prohibiting the use of dilution method for disposal.
- There are only a few coastal towns in India, which have strong tidal currents moving in the forward directions, and the necessary depth of water at the point of disposal, thus prohibiting the disposal of sewage in the sea on large scale.

Unit IV & V

Tanning Industry

Tanning Process

Sources of Waste Water and their Characteristics

Skins of cows and buffalos are called "Hides". Skins of goats and sheeps are called "Skins". Tanning is the art of converting animal skins into leather. The tannery wastes are characterized by strong color, high BOD, high pH and high dissolved salts. The tanning process consumes large quantities of water. Most of this water used is finally discharged as waste water carrying high amounts of suspended solids, dissolved solids, BOD, COD, strong colour, bad smell. Depending upon the type of process 30-40 litres of water is used to process each kilogram of raw hides or skin into finished leather.

Tanning Process :

The tanning process consists of three basic stages

1. Preparation of the hides for tanning.
2. Tanning proper.
3. Finishing.

Tannery wastes originate from the beam house and the tanyard.

In the beam house curing, fleshing, washing, soaking, dehairing, lime splitting, bating, pickling and degreasing operations are carried out. In the tanyard, the final leather is prepared by several processes. These include vegetable or chrome tanning, shaving and finishing. The finishing operation includes bleaching, stiffing and fat liquoring and coloring.

Protective treatment administered soon after the hides and skins are flayed is called curing. Curing involves dehydration of the hide by drying it with salt or air in order to stop proteolytic enzyme degradation. Curing creates an environment for the hides and skins in which the protein destroying organism cannot function. Its sole purpose is to ensure that the hides and the skins are protected during transit from slaughter house to the tanneries which are generally located some good distance away. It also facilitates storing.

Fleshing removes the fatty tissues from the skin by mechanical means. Cured hides and skins arriving at tannary are trimmed to remove long shanks and other unwanted areas.

Washing and soaking remove the dirt, salts, blood, manure and nonfibrous proteins and restore the moisture lost during preservation and storage.

Unhairing is accomplished by the use of lime, with or without sodium sulfide, this makes the skin more attractive and more amenable to the removal of trace protein impurities.

Lime splitting separates the skin into two layers, one is more valuable grain layer the other the lower or flesh side is called the split.

Bating prepares the hide for tanning by reducing the pH, reducing the swelling, peptizing the fibres and removing the protein degradation products.

Bating is generally accomplished with ammonium salts and a mixture of commercially prepared enzymes, the bathing bath renders the grain sticky, slippery, smoother and more porous increases its width and decreases its wrinkles.

Pickling generally precedes chrome tanning and involves treatment of the skin with salt and acid to prevent precipitation of the chromium salts on the skin fibers.

Degreasing removes natural grease, thus preventing formation of metallic soaps and allowing the skin to be more evenly penetrated by tanning liquors. Chrome tanning is used primarily for light leathers while vegetable tanning is preferred for most heavy leather products. The process of chrome tanning is of shorter duration and produces more resistant leather.

The second stage of leather making, the tanning proper, involves the treatment of the hides to make them non putrescible and even soft when dried.

In chrome tanning process the tanning is done in the same vat after one day of pickling by adding a solution of chromium sulphate. After 4 hours of tanning, the leather is bleached with a dilute solution sodium thiosulphate and sodium carbonate in the same bath. The third stage of finishing consists of stuffing and fat liquoring followed by dyeing. In the former process the tanned leather incorporates oil and grease and thus becomes soft and resistant to tearing. Dyeing can be done using synthetic dye stuffs.

Depending on the type of product, either vegetable substances containing natural tanning eg. the extract of barks, wood etc. or inorganic chromium salts.

Vegetable tanning produces leathers which are fuller, plumper, more easily tooled and embossed and less effected by body perspiration or changes in humidity. Dyeing to produce the final colored leather product is usually done with basic dyestuffs.

Sources of waste water and their characteristics :

The waste may be classified as continuous flow waste and intermittent flow waste. Continuous flow waste consists of wash wastes after various processes and comprise of a large portion of the total waste, and are relatively less polluted than the other one. Spent liquors belonging to soaking, liming, bating, pickling, tanning and finishing operations are discharged intermittently. Although these are relatively small in volume, they are highly polluted and contain varieties of soluble organic and inorganic substances. The waste water from beam house process viz. soaking, liming, deliming etc. are highly alkaline, containing decomposing organic matter, hair, lime, sulphide and organic nitrogen with high BOD and COD.

The spent soak liquor contains soluble proteins of the hides, dirt and a large amount of common salt when salted hides are processed. The spent liquor undergoes putrefaction very rapidly as it offers a good amount of nutrients and favourable environments for bacterial growth.

The spent bate liquor contains high amount of organic and ammonia-nitrogen due to the presence of soluble skin proteins and ammonia salts.

The vegetable tan extract contains tannins and also non tannins and high organic matter. Tannins are of high COD but relatively low BOD, while non tannins including inorganic salts, organic acids and salts and sugar are high both in COD and BOD. The waste water from tanyard process viz. pickling, chrome tanning are acedid and coloured.

The spent pickling and chrome tanning waste comprise a small volume, have a low BOD and contains trace of proteinic impurities, sodium chloride, mineral aids and chromium salts, mostly in the trivalent form.

The spent lime liquor contains dissolved and suspended lime and colloidal proteins and their degradation products, sulphides, emulsified fatty matters and also carry a sludge composed of unreacted lime, calcium sulphide and calcium carbonate. The spent liquor has a high alkalinity, moderate BOD and a high ammonia-nitrogen content.

Effects of waste on receiving water and sewers :

Tannery wastes are characterized by high BOD, high-suspended solids and strong color. These wastes when discharge as such deplete the dissolved oxygen of the stream very rapidly, due to both chemical and biological oxidation of sulfur and organic compounds.

A secondary pollution of the stream may occur due to the deposition of the solids near the discharge point and its subsequent putrefication. Presence of tannins in the raw water renders it unsuitable for use in certain industries.

The tannery waste when discharged into a sewer only chokes the sewer due to the deposition of solids, but also reduces the cross- section of the sewer arising out of the lime encrustation.

Treatment of waste :

The method of treatment of waste may be classified as physical, chemical, and biological. The physical treatment includes mainly screening and primary sedimentation. Screens are required to remove fleshings, hairs and other floating substances. About 98% of the chromium is precipitated in the primary sedimentation tanks and is removed along with the sludge.

Chemical coagulation, with or without prior neutralization followed by biological treatment is necessary for better quality of the effluent. Ferrous sulfate is reported to be the best coagulant for the removal of the sulfides and may be used for the effective removal of color, chromium, sulfides, BOD and suspended solids from chrome tan wastes.

Biological treatment of the tannery waste, in activated sludge process, after mixing with municipal waste water in a suitable proportion, and using acclimatized micro organisms capable to reduce the BOD, COD and tannin by about 90%. Trickling filters may also be used for effective removal of BOD, COD and color.

The low cost biological methods of treatment may effectively be used for the treatment of tannery wastes. Both oxidation pond and anaerobic lagoons are recommended for small and isolated tanners. For further improvement of the effluent quality the anaerobic lagoons may be followed by an aerated lagoon.

Composition of composite waste water	
pH	9.8 - 11.8
Organic solids	1500 mg/l
Hardness	1600 mg/l
BOD	1000 mg/l
Sulfides	1000 mg/l
Total solids	6170 mg/l
Chromium	40 mg/l

Textiles Mills Waste

The Fibres used in the Textile Industry may be broadly classified into four groups : cotton, wool, regenerated and synthetics.

Cotton textile mill waste:

An integrated cotton textile mill produces its own yarn from the raw cotton. Production of yarn from raw cotton includes steps like opening and cleaning, picking, carding, drawing, spinning, winding and warping. All these sequences are dry operations and as such do not contribute to the liquid waste of the mill.

Carding : It is a process in the manufacture of spun yarns whereby the staple is opened, cleaned, aligned and formed into a continuous untwisted strand called sliver.

Drawing : It is the process of increasing the length per unit weight of sliver.

Combing : A method to remove short fibers, foreign matter from cotton stock by pressing it through a series of needles or combs.

Spinning : It is a process by which a long strand of fibres is drawn out to a short strand and converted into a yarn. After drawing out, it is subjected to twisting and the resulting yarn is wound into a bobbin.

Winding :It is the process of transfer of a yarn or thread from one type of package to another.

Weaving :It is the process of interlocking two yarns of similar materials so that they cross each other at right angles to produce a woven fabric.

The entire liquid waste from the textile mills comes from the following operation of slashing (or sizing), scouring and desizing, bleaching, mercerizing, dyeing and finishing.

In slashing,(to give it the tensile strength and smoothness necessary for subsequent weaving) the yarn is strengthened by loading it with starch or other sizing substances. waste originates from this section due to spills,and the floor washings at the weak end.

After slashing the yarn goes for weaving.the prepared cloth now requires scouring and desizing to remove natural impurities and the slashing compounds.

Enzymes are usually used in India to hydrolyze the starch ; acids may also be used for this purpose.caustic soda, soda ash,detergents etc. are used In scouring in kier boilers. To remove the natural impurities such as greases waxes, fats and other impurities, the desized cloth is subjected to kier boiling i.e they are boiled with the aid of steam in an alkaline solution containing caustic soda. After boiling the spent liquor is discharged as waste. This is a strong waste, dark brown in colour, and highly alkaline. Temperature of the effluent is high. BOD of the liquor is also high, contributing 35% of the total waste. Replacement of soap used in scouring by low B.O.D detergents may reduce B.O.D load by 35% about 50%of the total pollution load of the mill is contributed by this section.

Bleaching operations use oxidizing chemicals like peroxides and hypochlorites to remove natural colouring materials and to render the clothes white.The bleaching process is necessary where fabrics are to be given a full white or where they are to be dyed in specific shades. In this process the natural colouring matter in the textile material is removed by the use of oxidising chemicals like peroxides and hypochlorites.

Mercerizing consists of passing the cloth through 20% caustic soda solution. The process improves the strength, elasticity , lustre and dye affinity. Waste from this section is recycled after sodium hydroxide recovery.

Dyeing may be done in various ways, using different types of dyes and auxiliary chemicals. Classes of dyes used include vat dyes, developing dyes, naphthol dyes, sulfur dyes, basic dyes, direct dyes etc.

Direct Dyes (Neutral Dyes) are used as they are easy to apply and no auxiliary chemicals are needed.

Basic Dyes : This class of dyes give bright colours. They are applied along with weak organic acids.

Sulphur Dyes : For dark colours, these dyes employed. These are sulphur compounds applied usually with sodium sulphide followed oxidation with chromate.

Vat dyes require caustic soda and sodium hydrosulfite to reduce the dye into a soluble form.

Sulfur dyes are reduced by sodium sulfide and oxidized by chromate.

Indigo dyes are also similar to vat dyes, but require only air oxidation.

Colour from the dyes vary widely and although those are not usually toxic, they are esthetically objectional when they impart colour in the drinking water supplies.

Thickened dyes, along with printing gums and necessary auxiliaries, are used for printing and subsequent fixation. After fixation of the prints, the fabric is given a thorough wash to remove unfixed dyes.

The finishing section of the mill imparts various finishes to the fabrics. Various types of chemicals are used for various objectives.

Composition of composite cotton textile mill waste	
pH	9.8 - 11.8
Total alkalinity	17.35 mg/l as CaCO ₃
BOD	760 mg/l
COD	1418 mg/l
Total solids	6170 mg/l
Total Chromium	12.5 mg/l

Woolen Textile Mills waste :

Wool wastes originate from scouring, carbonizing, bleaching, dyeing, oiling, fulling and finishing operations.

Impurities of raw wool, consisting mainly of wool grease and other foreign matter are removed by scouring the wool in hot detergent alkali solution. Some wool are scoured by organic solvents.

Wool grease may be recovered from the scouring waste by centrifuging, coagulation or floating and may be processed further for the production of lanoline and potash.

Carbonizing is a process in which hot concentrated acids are used to convert vegetable matter in the wool into loose charred particles, followed by mechanical dusting of the same.

Wool may be dyed at any stage, either as raw stock, or after spinning and weaving. Normally hot dye solutions are circulated through the wool, packed in a metal container.

In oiling, usually olive oil or a barg-oil-mineral-oil mixture is sprayed over the wool to aid in the spinning. Fulling is an operation where the loosely woven wool from the loom is shrunk into a tight closely woven cloth. To aid this process, chemicals like soda ash, soap etc are used. Excess fulling chemicals, all of the oil etc are washed out of the fabric in a finishing process.

Waste from a dyeing and finishing process are contributed by the spent liquors and by subsequent washing of wool after bleaching, dyeing and finishing.

Characteristics of a typical wool waste :	
pH	9-10.5
Total alkalinity	600 mg/l
BOD	900 mg/l

Colour	Brown
Total solids	3000 mg/l
Suspended solids	100 mg/l
Total Chromium	4 mg/l

Effects of the cotton textile and woolen textile mill wastes on receiving streams / sewers :

The crude waste, if discharged into the streams, causes rapid depletion of the dissolved oxygen of the streams. The condition aggravates due to the settlement of the suspended substances and subsequent decomposition of the deposited sludges in anaerobic condition. The alkalinity and the toxic substances like sulphides and chromium affect the aquatic life; and also interfere with the biological treatment process; some of the dyes are also found toxic.

Treatment of Cotton and Woolen Textile Mill Waste :

The pollution load of the waste is dealt with in the operations like segregation , equalization , neutralization, chemical precipitation , chemical oxidation and biological oxidation. Several chemicals are used to reduce the BOD by chemical coagulation. These are alum, ferrous sulfate , ferric sulfate, ferric chloride etc., lime or sulfuric acid is used to adjust the pH in this process. Calcium chloride is found to be effective in treating wool-scouring waste.

The dye wastes may be treated economically by biological methods, with prior equalization , neutralization and chemical oxidation for certain wastes.

A composite waste, when free from toxic substances may be treated as efficiently as domestic sewage, as most of the textile mill wastes contain sufficient nutrients like nitrogen and phosphorus. Trickling filters, Activated Sludge Process , Waste Stabilization ponds, all these types of biological treatment have been tried for the treatment of textile mill wastes and all of them are found to be very effective. Excellent results were also obtained with Extended Aeration in treating a strong waste , even without any equalization and pre-treatment; this method eliminates the necessity of sludge digestion as well.

Synthetic Textile Mill Waste :

The most prominent man made synthetic fibers are Rayon, nylon and polyester. These fabrics require no processing for the removal of natural impurities as they are man made.

Manufacture of synthetic fabrics involve two steps:

- (i) manufacture of the synthetic fibre and
- (ii) preparation of the cloth.

These two steps may be carried out either in one integrated plant, or may be separated in two different plants.

Wastes from the manufacture of the synthetic fibre resembles chemical manufacturing wastes, and depends entirely on the raw materials used and the process adopted. A typical synthetic fibre Nylon-6 is obtained through polymerization of caprolactum and subsequent pelletization , drying , remelting in extruders , spinning and twisting.

The wastes from this manufacture are usually characterized by a colloidal type turbidity , a typical colour , a low alkalinity (pH around 7.5) , high amount of total solids in the order of 2500 mg/l and comparatively small amount of suspended solids. The waste usually contains a large amount of nitrogen, entirely of organic origin. The waste is also characterized by a high COD value (in the order of 500 mg/l) though the BOD is found to be very low (around 50 mg/l)

Treatment of Wastes from Synthetic Textile Mills :

Dairy Wastes

Units Operation in a Dairy :

Receiving Stations

The receiving station serves as a collection point for raw milk from the farmers. When milk is delivered to the dairy in cans and these cans are emptied, rinsed and washed and in some cases sterilized before returning.

Bottling

Raw milk received is weighed and classified (generally based on the fat content), it is preheated, pasteurized, cooled and then filled into bottles, polythene bags, cardboard packets etc.

Product Making

Dry milk, milk powder, cheese, butter and other products as ice cream, condensed milk are prepared out of milk.

Sources of wastes:

Waste producing operations are washing of bottles, cases, cans, tanks, cooling equipment, Processing equipment and floors.

Dripping, leaks, spillages and overflows due to improper equipment or inefficient operation.

Discharges from evaporators.

Wasted buttermilk and whey (watery liquid left when milk forms curds).

Spoiled raw or treated products.

Classification of Waste:

- Spent waters: Water used for condensing and free from milk solids. These are easily disposed off.
- Waste waters produced during handling and manufacturing of dairy products as :
- (i) Spoiled products of skim milk, whey and buttermilk.
- (ii) Drips, leaks, first rinses and alkaline wash waters. Whey and buttermilk have high BOD.

Characteristics of wastes:

They are wholly organic with high oxygen demand (Milk is a balanced food for bacteria, therefore it is consumed at a faster rate depleting the oxygen)

1kg of whole milk produces about 10kg of BOD

BOD= 300 to 3000mg/l and BOD/COD very high (0.68) indicating degradability of the waste.

Heavy black sludge and strong butyric acid odors because of decomposition of casein are common. Also, these wastes contain nitrogen and phosphorous which are excellent nutrients for algae and other aquatic plants, which on death add to the taste and odour of the waste water.

Composition:

Parameter	Value
pH	7.2
C.O.D mg/	
B.O.D mg/l	1240mg/l
Alkalinity	600 mg/l as CaCO ₃
Total Dissolved Solids	1060mg/l
Chlorides	105mg/l
Nitrogen	80mg/l
Phosphates	10mg/l
Organic Grease	290mg/l
Suspended Solids	760mg/l

Treatment of Waste:

As evident from the high BOD/COD ratio, the dairy wastes can be treated efficiently by biological processes.

Reduction of volume and strength of the wastes by:

- i. Prevention of spills, leakages and dropping of milk from cans.
- ii. By reducing the amount of water for washes
- iii. By segregating the uncontaminated cooling water and recycling the same.

Due to the intermittent nature of the waste discharge, it is desirable to provide, Equalization tank with or without aeration before the same is sent for biological treatment. A provision of grease trap is also necessary as a pretreatment to remove fat and other greasy substances from the waste. An aeration for a day not only prevents the formation of lactic acid, but also reduces the BOD by about 50%. Both high rate trickling filters and activated sludge plants can be employed very effectively for a complete treatment of the dairy waste. On the other hand the low cost treatment methods like oxidation ditch, aerated lagoon, waste stabilization pond etc can be employed with simpler type of equipments and less maintenance.

Waste Equalization→Aerator→grease Trap→Biological Treatment ASP/TF low cost→Effluent
Use of dairy waste for irrigation after primary treatment in an aerated lagoon.

Breweries Wineries Distilleries

Introduction :

While Breweries and Wineries produce beer and wine respectively, a large number of products of varying origin are obtained in Distilleries. The range of products from distilleries includes industrial alcohols, rectified spirit, silent spirit, absolute alcohol, beverage alcohol etc.

But two things are common all the products:

1. All the products are obtained through the bio-chemical process of fermentation by yeast, using carbo-hydrates as raw materials
2. All the products contain ethyl alcohol in different proportions.

Origin and Characteristics of Breweries Wastes

Making of beer essentially consists of two stages:

- 1.Preparation of malt from grains like barley and
- 2.Brewing (boiling and fermentation) the Barely.

In malt making, the barely grains are steeped (soaked in liquid) to bleach out colour, and then made to sprout (appear or begin to grow) under aerobic conditions. The grain malt is then dried and stored after screening the sprouts out.

The malt from the malt house is then transported to the brewing section, where the wort (infusion of malt before it is fermented into beer), the medium of fermentation is prepared by making a

mash of coarse grained malt with hot water, and by transforming the starch to sugar by boiling with hops (which are used to give a bitter flavour to beer.).

The wort is then filtered and cooled. The filtered wort is then inoculated with a prepared suspension of yeast, which ferments the sugar to alcohol.

When the fermentation is complete the yeast and malt residue is filtered out and finally the beer is carbonated before packing for sale.

Brewery Wastes Originate in both these stages. One being the spent water from the steeping process from the malt house. The waste includes the water soluble substances of the grain that are diffused into it. Characteristically it contains a large amount of organic soluble solids indicated by a high B.O.D in the order of 400-800mg/l and low suspended solids.

In the brewing plant, the major potential pollutant is the fermentation residue or the spent grains. Wastes also originate in the preparation of yeast suspension, from washing of containers, equipments and floors. Large volume of almost on polluted water also comes out as waste cooling water.

The waste from the brewing plant contains high-suspended solids and also a high B.O.D

Origin And Characteristics of Distilleries Waste:

The beverage alcohol industries utilize different grains, malted barley and molasses as raw materials. on the other hand the molasses (black strap type) are exclusively used as raw materials in the industrial alcohol industry.

In beverage alcohol industry, the preparation of mash consists of:

1. Preparation of green malt
2. Preparation of cooked slurries of the grains
3. Mixing of the above two followed by ph adjustment and nutrient (ammonium salts and phosphates) supplementation.

On the other hand in molasses distilleries, the preparation of mash consists of:

1. Dilution by water to a sugar content of about 15%
2. pH adjustment to 4.0 - 4.5 to prohibit bacterial activities and
3. Nutrient addition.

The yeast suspension is prepared separately in the laboratory with art of the diluted molasses and then inoculated into the mash for fermentation under controlled conditions. The fermented liquor

containing alcohol is then sent to an overhead tank without separation of the solid materials. The same is then degasified, and then the alcohol is stripped leaving a spent wash. The crude alcohol is then redistilled and stored in vats. The spent wash is the major polluting component of the distilleries and it is reported to be ten to fifteen times the final product in volume. The other pollutants include yeast sludge, which deposits at the bottom of fermentation vats. Malt house wastes also contribute towards pollution in beverage alcohol distilleries. In addition to these major B.O.D and solids contributing wastes, floor washes, waste cooling water, and wastes from the operations of yeast recovery or by-products recovery process also contribute to the volume of these wastes.

Characteristics of Compositd Combined Waste

Parameter	Value
pH	3.9 - 4.3
C.O.D mg/	27900 - 73000
B.O.D mg/l	12230 - 40000
Total Solids mg/l	16640 - 26000
Suspended Solids mg/l	4500 - 12000
Alkalinity	3 80 - 510

Composition of Malt House & Combined brewery wastes:

Parameter	Malt House Waste	Brewery Waste
pH	6.9- 9.5	4.0 - 7.0
Total solids, mg/l	428 - 700	272 - 2724
Total Nitrogen(N)mg/l	14 - 56	7 - 42
C.O.D , mg/l	31 - 175	30 - 1225
B.O.D, mg/l	20 - 204	70 - 3000
Suspended solids ,mg/l	22 - 339	16 - 516

Origin And Characteristics of Wineries Waste:

The wineries utilize the fruit juices as the raw materials. So the first operation in any winery is the pressing of fermentable juice from the fruits like grape etc. The waste from this operation

includes the spent fruits or pomace, wastage of fermentable juices and floor wastes etc. The second stage in any winery consists of fermentation of this juice employing the method described earlier.

The wine attains its final form at this stage and requires only decantation, blending and bottling for sale.

The waste from this stage comes from fermentation, decanting spillages, floor washes etc

Characteristics of Combined Wastes from Brewery, Winery and Food Processing Units:

Parameter	Value
pH	4.0
C.O.D mg/	1800 - 3000
B.O.D mg/l	1500 - 2000
Colour	brownish yellow
Dissolved Solids mg/l	6800 - 9400

-

Effects on Receiving Streams/Sewers:

While Breweries and Wineries produce beer and wine respectively, a large number of products of varying origin are obtained in Distilleries. The range of products from distilleries includes industrial alcohols, rectified spirit, silent spirit, absolute alcohol, beverage alcohol etc.

But two things are common all the products:

1. All the products are obtained through the bio-chemical process of fermentation by yeast, using carbo-hydrates as raw materials
2. All the products contain ethyl alcohol in different proportions.

Treatment of the Wastes:

Brewery wastes being comparatively less strong can be treated by aerobic biological treatment, after screening and neutralization. The biological treatment is accomplished by two-stage process for 90 - 94% B.O.D reductions.

The yeast sludge from the distilleries which contains very high suspended solids and B.O.D and is rich in proteins, carbohydrates, vitamins may be treated separately for by product recovery.

The raw spent wash with low pH, high dissolved solids, high temperature, high sulphates, and high B.O.D is not amenable to aerobic biological; treatment. Two-stage biological methods of treatment consisting of an aerobic treatment have been widely accepted as the only methods of treatment of the wastes from the distilleries.

A single stage digester is usually adopted for the anaerobic treatment when land available is limited. Anaerobic lagooning is a low cost alternative to the digesters when land is available in plenty. The only disadvantage of anaerobic lagoons is the evolution of volatile gases and obnoxious odour from the ponds.

Effluent of the digesters and the anaerobic lagoons still contain a high B.O.D, which cannot be discharged into the receiving streams. These effluents can successfully be treated either in aerated lagoons, or in oxidation ponds.

By-Product Recovery:

The yeast sludge from the distilleries contains the degradation product of the dead yeasts and organic debris from the malt s like proteins, fats, vitamins and carbohydrates. On the other hand the spent wash contains all the above nutrients plus unfermented sugars, amino acids, ammonium phosphates etc. So two types of by products viz. the nutrient rich animal feed, and the potassium rich fertilizers may be recovered in a distillery.

The segregation of yeast sludge for processing for animal feed is practiced in some distilleries, which in turn reduces the insoluble B.O.D load of the waste.

Meat Packing Wastes

Meat Processing

Meat is the dressed flesh derived from cattle, buffalo, sheep, goat, pigs and poultry.

Meat being a highly perishable product, can be kept in a fresh condition only through proper processing and storage. When meat gets spoiled it becomes slimy or sticky, turns dark brown and develops an unpleasant smell and taste. Meat is preserved in a number of ways such as freezing, curing, smoking, dehydration and canning.

Processed meat : Almost all the meat produced in India is consumed as fresh meat, only pork and a very small quantity of mutton and beef is preserved and processed into different products.

Three major sources of wastes of meat industry are from

1. Stockyards
2. Slaughter House and
3. Packing House

The Stockyard wastes consists primarily of animal manure with urine, straw and unconsumed food along with dirt and water used for cleaning. The stockyard waste are strong and posses a very high BOD.

Killing, dressing and some by product processing are carried out in the slaughter house. The animals are stuck and bled on the killing floor. Flushing of killing floors contribute significant volumes of strong waste waters. Then hides and are skins are removed, salted and piled in separate place.

In Packing house meat is further processed by cooking, curing, smoking and pickling. The other processes carried out in Packing house are meat canning, sausage manufacture, rendering of edible and inedible fats to edible and inedible tallon respectively. The effluent from killing floor is deep reddish brown in colour, a high BOD and suspended matter.

Origin and Characteristics of Meat Packing Wastes :

Stockyard wastes contain excreta, both liquid and solid. The amount and strength of the waste vary widely, depending on the presence or absence of cattle beams (horns), how thoroughly or how often manure is removed, frequency of washing etc.

Stockyard Waste

Parameter	Value
B.O.D	64 mg/l
Organic nitrogen	11mg/l
Volatile Suspended Solids mg/l	132 mg/l
Total Suspended Solids mg/l	173 mg/l

Treatment of Meat Packing Wastes:

In plant recovery practices, screening, floatation and biological treatment are the major methods used to treat meat plant wastes. The most common methods used for treatment of meat plant wastes are fine screening, sedimentation, chemical precipitation, trickling filters and activated sludge process.

Screening by rotary wire mesh removes coarse materials such as hair ,flesh and floating solids. Sedimentation in imhoff tanks is also satisfactory being capable of removing 63%of suspended solids and 35%of B.O.D. tf and asp can give 80-90%of removal.

Rice Milling Waste :

In the preparation of edible rice, large volumes of wastes are produced in the soaking ,cooking and washing processes.Since most of the B.O.D is in the form of colloidal and soluble materials ,settling effects only a 29%reduction.60%of B.O.D reduction has been obtained by using 2000ppm of lime as a coagulant ;digestion can yield a B.O.D reduction of over 90%.

Characteristics of composite rice water :	
pH	4.2-7.0
Suspended solids	610mg/
Total nitrogen	30mg/l
BOD	1065mg/l
Starch	1200mg/l

Pulp and Paper Mill Waste

The paper mills use the 'pulp' as the raw material , which is again produced utilizing different cellulosic materials like wood , bamboo,jute, straw mainly of rice and wheat, waste paper, bagasse etc in the pulp mills.

Manufacturing Process :

The Process of manufacturing of paper may be divided into two phases - Pulp making and then making of final product of paper.

The major portion of the pollution from papermaking originates in the pulping processes.

Raw materials are reduced to a fibrous pulp by either mechanical or chemical means.

The bark is mechanically or hydraulically removed from wood before it is reduced to chips for cooking.

Mechanically prepared (groundwood) pulp is made by grinding the wood on large emery(very hard mineral) or sand stone wheels and then carrying it by water through screens.

This type of pulp is low-grade , usually highly colored, and contains relatively short fibers, it is mainly used to manufacture non durable paper products such as newspaper. The screened bark effluent contains fine particles of bark and wood and some dissolved solids.

Chemically prepared pulps, as compared with mechanically prepared ones, are made by the soda, sulfate (Kraft) or sulfite process. In all these methods the wood is prepared, as in the making of groundwood, by reduction to chips and screening to remove dust. The chemical processes differ from one another only in the chemical used to digest the chips.

Pulping is the process in which wood or other cellulosic raw materials are digested with chemicals under high temperature and pressure so that cellulosic fibres of wood are relieved from its binders such as lignin, resin etc

To a digester holding about four cords(128 cft) of chips, a mixture of soda ash (Na_2CO_3) and Lime($\text{Ca}(\text{OH})_2$) (alkali process) is added and the total contents are boiled under steam pressure for about ten hours. This digestion decomposes or separates the binding , non cellulosic materials , such as lignins and resins from the fiber.During digestion most of the lignins are hydrolysed to alcohol and acids.

The spent liquor produces by the above process of digestion is known as black liquor. Black liquor very rich in lignin content but also contains a large amount of unutilised chemicals.The black liquor of the Kraft process is concentrated by evaporation, and then incinerated with the addition of sodium sulphate. The organics like lignin, resin etc are burnt out, and the spent is dissolved in water. The resulting liquid is known as green liquor. Lime is added to this liquor, resulting in the formation of white liquor and lime mud containing chiefly calcium carbonate. White liquor contains desired cooking (digestion) chemicals and is sent for use in digester.

The sulfate process calls for a shorter digestion period of about five or six hours , with a mixture of sodium sulfide, hydroxide , sulfate and carbonate . The lignin and non cellulosic materials are dissolved , leaving a stronger fiber for paper formation.

After digestion, chemically prepared wood pulps are blown into a closed blow pit, where the black liquor is allowed to drain to the sewer or to the recovery processes.

The drained pulp is then washed . These wash waters may then be wasted, reused or sent through recovery operations while the washed pulp is passed through some type of refining machine to remove knots and other non disintegrated matter.

A cylindrical screen, called a Decker , revolving across the path of the pulp partially dewateres it, after which it is passed to bleach tanks, where it is mixed in a warm, dilute solution of calcium hypochlorite or hydrogen peroxide. The dried , bleached pulp is then ready for sale or delivery to the paper mill.

The washed cellulosic fibres are sent for the bleaching in 3 stages, where chlorine, caustic and hypochlorite are used in successive stages. Waste waters from first and last stages are light yellow in colour, while that from caustic highly coloured.

In the paper mill, the pulp mixture is disintegrated and mixed in a Beater to which are added various fillers like alum, talc etc and dyes, to improve the quality of the final paper product, and sizing to fill the pores of the paper.

The Beater is essentially an oblong tank equipped with a rotating cylinder, to which are attached dull knives to break up the knotted or bunched fibers and cause a through mixing of the entire contents of the tank.

Sometimes the pulps are washed in the 'breaker beater ' prior to the addition of chemicals. After beating, the pulp is usually refined in a Jordan, machine that consists of a stationary hollow cone with projecting knives on its interior surface, fitted over a rapidly rotating adjustable cone having similar knives on its outside surface. This machine cuts the fibers to the final size desired.

The pulp then passes to stuffing boxes, where it is stored, mixed and adjusted to the proper uniform consistency for papermaking.

Finally the pulp is screened to remove lumps or slime spots, which would lower the quality of the final paper.

The pulp is evenly distributed from a head box over a travelling belt of fine wire screening , known as fourdrivein weir , and carried to rolls . A small portion of the water contained in the pulp passed through the screen while the longer fibers are laid down as a mat on the wire . A considerable portion of the fine fibers and some fillers also pass through the screen wire with the water. Because of its colour, this waste water is called white water.

The paper mat passes through a series of rolls as follows ; a screen roll to eliminate inequalities at the end of the wire, a suction roll to draw out more water, press and drying rolls to rid of the paper of most of the remaining water and finally finishing rolls(Calenders) which produce the final shape of the paper.

Characteristics of pulp and paper mill wastes :

The volume depends mainly on the manufacturing procedure, and the water economy adopted in the plant. It has been observed that a well operated and well managed integrated pulp and paper mill employing Kraft process for pulping , produces a waste volume in the range of 225 to 320 m³ per tone of paper manufactured. The mills manufacturing special quality of paper produce larger amount of water for washing and bleaching.

Like the volume of waste, the chemical composition of the waste will also depend on the size of the plant, manufacturing process. In most of the small paper mills in India, the chemical recovery is not practiced due to economical reasons.

The pulp and paper mill wastes are characterized by very strong colour, high BOD , high suspended solids and high COD/BOD ratio.

	Small Mill - (<20 t of paper/day)	Large Mill - (2000 t of paper/day)
pH	8.2 - 8.5	8.5 - 9.5
Total solids, mg/l	----	4410
Suspended solids , mg/l	900-2000	3300
COD , mg/l	3400-5780	716
BOD, mg/l	680-1250	155
Colour	Dark Brown	Dark Brown
COD/BOD	3.9-5	4.6

The effect of wastes on receiving water courses or sewers:

Crude pulp and paper mill wastes, or insufficiently treated wastes cause very serious pollution problems, when discharged into the streams.

The fine fibers often clog the water intake screens in the down stream side. A toxic effect may also be induced upon the flora and fauna of the stream due to sulfites and phenols in the waste.

The bottom deposit of Lignin - Cellulosic materials near the point of the discharge of the waste in a stream undergo slow decomposition and may lead to the dissolved oxygen depletion followed by the creation of anaerobic condition and destruction of the aquatic life.

The treatment of the waste may consist of all or a combination of some of the following processes :

Recovery : The recovery of the process chemicals and the fibres reduces the pollution load to a great extent. Where the economy permits the colour bearing black liquor is treated for the chemical recovery. In this process the lignin is destroyed. The same may also be recovered from the black liquor, by precipitation by acidulation with either carbon dioxide or sulphuric acid. The fibres in the white water from the paper mills are recovered either by sedimentation or by floatation using dissolved air in the tank.

Chemical treatment for colour removal : Massive lime treatment capable of removing 90% of colour and 40 to 60% of BOD from the waste. In this process, entire quantity of lime, normally required for the recaustisation of green liquor into white liquor, is taken and allowed to react first with the coloured waste effluent. The colour is absorbed by lime and the sludge after settling is used in recaustising the green liquor.

Activated carbon for colour removal: In a study conducted by NEERI, it has been observed that acidic activated carbon can remove 94% colour from the pulp mill waste

Physical treatment for clarification: Mechanically cleaned circular clarifiers alone are found to be capable of 70-80% removal of the suspended solids from the combined mill effluent. About 95 to 99% removal of settable solids can be accomplished in the clarifiers. However the BOD reduction is comparatively small and of the order of 25-40% only.

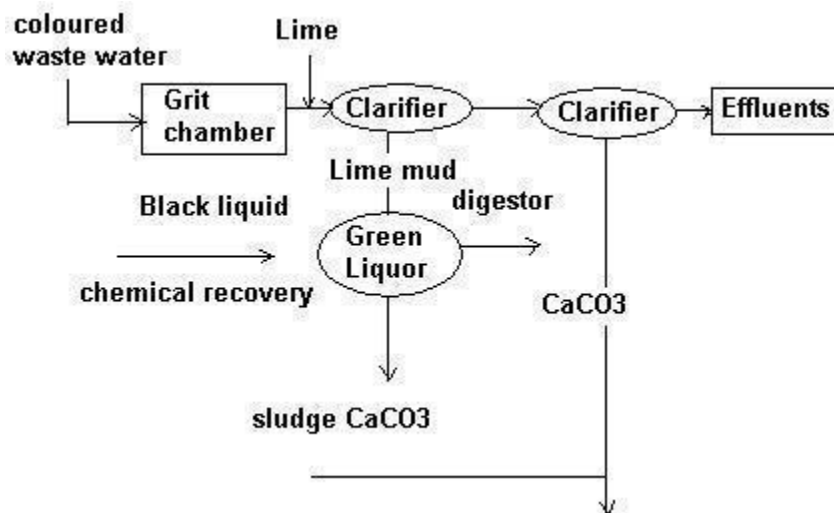

Biological treatment of the waste: Considerable reduction of BOD from the waste can be accomplished in both conventional and low cost biological treatment processes. If sufficient area is available, the waste stabilization ponds offer the cheapest means for treatment. A minimum of 85% removal of BOD is found to be achievable. Aerated lagoons are the improved forms of the stabilization ponds. It may be noted that

the pulp and paper mill wastes does not contain necessary nutrients for the bacterial growth, and hence Nitrogen and Phosphorous are to added into the lagoons in the form of Urea or Ammonia and Phosphoric acid in BOD: N: P ratio of 100:5:1. Activated sludge process is the most satisfactory and sophisticated system for the effluent treatment. Trickle filter has got a limited use in the treatment of the pulp and paper mill effluent, due to the greater chances of clogging of the media with fibrous material. Also the trickle filter system is incapable to provide a high degree of treatment -even with the new plastic media with greater specific surface area the BOD removal is found to be only 40-50%.

Lagooning : In small mills , where the black liquor is not treated separately for the chemical recovery, the strong black liquor must be segregated from the other wastes and stored in a lagoon.

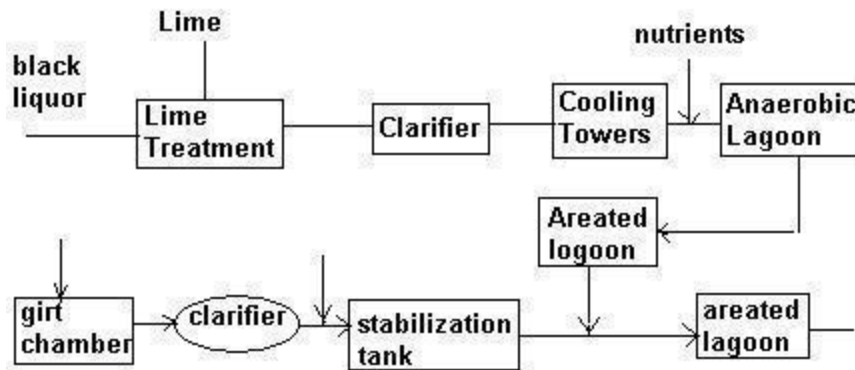

Steel Plant Wastes

Introduction

Integrated steel plants usually consist of five main units, Viz; Coal washery, Coke oven blast furnace, steel melting shop and rolling mills. In addition to the above the plants may have auxiliary units like oxygen plant and power plant for their own uses.

Coal washery and its wastewater: The coal needs some processing to make it suitable for use in coke ovens. The main objective of such treatment is the removal of solid foreign matter present in the coal. Generally the process in a coal washery include crushing, screening and wet washing of coal. In the wet process the coal is separated from the impurities using the principal of differential settling. Water used for washing is recycled and reused after sedimentation. But in spite of all care taken to ensure maximum reuse, appreciable quantity of wash water containing coal fines, and other impurities like clay and small amounts of other minerals like calcite, gypsum, pyrite etc, comes out as waste, normally in a thickened form as the under- flow of the sedimentation tank.

Coke Ovens and their Water Waste

The production of coke involves the carbonization of bituminous coal by heating in the absence of air at a temperature range of 900 - 1100 degrees centigrade in an oven, which drives off all volatile portions in the coal. The gas which is evolved containing the volatile matters is collected through the stand pipes and is cooled in stages. In the first stage the gas is cooled to about 80 degrees centigrade by spraying cold liquor over the gas, there by producing mainly tar as condensate. In the second stage by a further cooling to about 30 degrees centigrade, condensate containing additional tar and ammonia liquor is produced. These two condensate liquors after the separation of tar in a tar-decanter are recycled as sprays in the first stage.

The excess liquor known as 'Ammonia-liquor' containing mainly ammonia and various other compounds is subjected to distillation for the recovery of ammonia; the waste is sent for further treatment or other chemical recovery. After the second stage of cooling i.e in the third stage, the gas is compressed and cooled for further recovery of chemicals. Besides the arrangement for separation of tar and ammonia, this stage may include a benzol washer for the recovery of light oils. The remaining gas may be used or sold as fuel. The coal after being carbonized is removed from the oven and quenched by cold water.

About 30% of the quenching water is evaporated while the remaining water containing coke fines comes out as waste. This wastewater is usually re-circulated through breeze settling ponds and does not present any pollution problem. The largest single source of wastewater from coke oven plant, having the highest pollution potential in an integrated steel plant is the ammonia still from where the waste ammonical liquor comes out. The second source of wastewater is the benzol plant, the pollution potential and the volume of waste from which are much smaller compared to the first.

Characteristics of Coal Washeries

Parameter	Value
Total Solids	1000 - 25000 mg/l
Suspended Solids	800 - 24700 mg/l
Dissolved Solids	200 - 300 mg/l

Hardness	230 mg/l as CaCO ₃
Alkalinity	86 mg/l as Ca CO ₃
Ph	7.4 - 7.8

Characteristics of a typical spent ammonical liquor

Parameter	Value
Ph	7.5-8.0
Total free ammonia	300-350mg/l
Total phenol	900-1000mg/l
Cyanides	10-50mg/l
Thio-cyanates as CNS	50-100mg/l
Thio-sulphates	110-220mg/l
Sulphides	10-20mg/l
Chlorides	4000-4200mg/l

Typical benzol plant waste

Parameter	Value
Ph	6.0 - 8.5
ammonia	5 - 30mg/l
phenol	30 - 150mg/l
5day BOD	300 - 800mg/l

Treatment of Coke Owen Waste

All the pollutants of the spent ammonical liquor, affect the ecology of the waste receiving water course, the phenol is considered to be the most objectionable pollutant. The other objectionable substances include thio-cyanate, thio-sulphate, cyanide etc. In some plants spent ammonical liquor is utilised for quenching of hot coke, this practice destroys the toxic matters like phenols in the liquor, But as this causes heavy corrosion in the quenching cars and in other quenching equipments , the method is not generally favoured. Phenol being a valuable chemical by-product, may be recovered instead of destroying it. Several techniques have been developed for the recovery of phenol by liquid extraction methods.

Most of these processes use Benzene as solvent, to extract phenol from the crude ammoniacal liquor, before it enters the Ammonia still for ammonia stripping. Other solvents used include light oil, petroleum oil etc. The extracted phenols from all absorption process can be recovered by washing with sodium hydroxide solution; the phenol reacts with the caustic solution to produce sodium phenolate. The crude phenol is then liberated from it using gases containing carbon dioxide.

Certain microorganisms both bacteria and yeast, are identified which can oxidise biologically phenols, thio cyanates, thio sulphates and ammonia. When optimum pH and temperature are maintained, sufficient nutrients are added, and the reactor is suitably seeded, the proper loading of this phenolic substrate to the reactor may result in the desirable reduction of the pollution load of the waste. Phenol in concentrations as high as 800 mg/l may be treated biologically.

In all practical cases, the phenol concentration in the waste ammoniacal liquor's too high to be treated directly by biological means. So these are either pretreated by physical or chemical methods, or are diluted using other waste to reduce the concentration of phenols.

When coal washeries waste is available it has been shown that considerable reduction in the strength of ammoniacal liquor can be accomplished when equal volumes of coal washeries waste and ammoniacal liquor is mixed and flocculated with lime in a clariflocculator. Effluent of the clariflocculator may then be sent for Activated Sludge Process.

The biological treatment of the coke oven effluents can be carried out economically in a three stage process, with isolated or cultured bacteria, appropriate in each stage. In the first stage the phenol is oxidised, in the second stage the thio sulphate and thio cyanate are reduced, and in the third stage the ammonia is oxidised.

Treatment of Coal Washery Waste

The major pollutant of the coal washery is the suspended solids. As such this waste is usually treated in a Clarifier with or without coagulation. However the addition of Coagulant reduces both the detention time and surface area of the tank. Several coagulants like lime, starch and indigenous coagulants like Nirmali seed extracts can be used effectively for the clarification of coal washery wastes. The clarified effluent is either recycled or discharged as waste.

Blast Furnace and its Wastewater

Blast furnace is a basic unit in an integrated steel plant. Essentially the blast furnace process consists of charging iron ore and coke as fuel limestone and dolomite as fluxing material into the

top of the furnace and blowing heated air (blast) into the bottom. Pig iron is the metallic product of this unit. Appreciable quantity of water is used in blast furnace for the purpose of cooling and gas cleaning operations. However, the cooling water normally remains un-contaminated and is reused after cooling.

The entire quantum of wastewater originates from the gas cleaning operations. The blast furnace gas, which is heavily loaded with flue dust, is cleaned in a three stage process.

The major portion of the flue dust which comes out along with blast furnace gas is recovered by the dry dust catchers. The remaining is removed by washing with water by “Wes Scrubbing”. The portion which escapes wet scrubber may be removed by electrostatic precipitator. In wet scrubber the down flow water sprays clean the dust from the up flowing gases and the wastewater contains 1000-10000 mg/l of suspended solids.

Characteristics of Typical Blast Furnace Waste

Parameter	Value
Total Dissolved Solids	346 - 500mg/l
Total Suspended Solids	1000 - 10500 mg/l
Dissolved Solids	80 - 118 mg/l as CaCO ₃
Total Hardness	230 mg/l as CaCO ₃
Total Alkalinity	380 mg/l as CaCO ₃
Chlorides	210 - 250 mg/l
Ph	7.3 - 8.2

Treatment of Blast Furnace Waste

The blast furnace waste contains about 40% of the total dust coming out of the blast furnace along with the flue gas. Iron oxide and silica comprise about 70% and 12% respectively of the flue dust content. The waste can be treated in a clariflocculator even without the addition of coagulant. However the flocculation time can be reduced to a great extent when certain coagulants like alum or lime is added. The efficiency of the clariflocculator can be increased alternatively by a judicious mixing of this waste with the other wastes of the steel plant. The oxygen plant waste containing sodium hydroxide, may be used for this prupose.

Steel Melting Shop and its Wastes

In the steel melting shop, the pig iron obtained from the blast furnace is further treated to produce ingots. The basic principle involved is the oxidation of unwanted impurities in the pig

iron which lead to the production of steel ingots. Water requirement in the steel melting process lies in keeping the furnace body cool. And as such this water remains uncontaminated and is reused.

Rolling mills and their wastes :

The steel ingots obtained from the steel melting shop are rolled to different products in the rolling mills however, the ingots are treated first in the soaking pits until these are plastic enough for economic reduction by rolling. Ingots are usually rolled into bloomes, billets or slabs depending upon the final product. These rolled bloomes, billets and slabs are then cooled and stored and subsequently sent to another mill, where these are re-rolled to produce finer products. During the process of rolling of ingots, blooms, billets and slabs, lots of scales are given off and are collected in the scale flume, below the roll tables. These scales are flushed down with high-pressure water and are collected at the scale pit.

The rolls also get heated during the process and are cooled with liberal supply of water. Naturally it carries lot of oil and grease used in different bearings.

When ever finer products like sheets, strips etc are required the products from hot rolling mills are normally subjected to cold rolling. For the production of cold reduced steel sheets it is essential however to remove the surface oxides of the steel slabs before they are subjected to rolling. The removal of oxides is essentially done by a process known as 'pickling' at an earlier stage.

Bloom - intermediate stage of manufacture of iron.

Billets – Short cyclinders

The pickling is essentially a process in which the hard black oxides formed on the surface of the products during the hot rolling is removed by immersion in acid. Normally either sulfuric acid or hydrochloric acid is used for this purpose. The acid react with the iron oxide scales, and forms ferrous sulfates. Where sulfuric acid is used for pickling the process can be continued until the build up of ferrous sulfate reaches to strength of 25% and the free acid content reduces to less than 5%. The used pickling liquor is then discharged and a fresh batch of acid is taken up.

After pickling and cold rolling the finer products are subjected to various finishing operations viz tinning, plating, Galvanizing, wire drawing etc. the waste generated in these operations may be contaminated with chromate, cyanide, fluoride, zinc, tin, copper acids and alkalies.

Characteristics of a typical hot rolling mill waste

Parameter	Value
Total Suspended Solids	320 - 600 mg/l
Total Hardness	80 - 118 mg/l as CaCO ₃
Oil and Grease	60-80 mg/l
Ph	7.8 - 8.1

-

Treatment of Scale-Pit Effluents

The primary treatment of the scale bearing waste from the rolling mills are offered by the scale pits associated with the different sections of the mill. The scales produced in primary mills, like blooming mills etc are coarse and mostly settle in the scale pit itself. The substantial quantity of finer scales produced in the process of rolling the billets, slabs etc are also settled in the associated scale pits.

The effluent from the scale pits still contains considerable amount of fine scales, oil and grease and requires secondary treatment.

The above effluent contains about 170 to 440 mg/l of suspended solids, and can be treated well in the clariflocculators using either sodium hydroxide or the oxygen plant waste as coagulant.

The iron content of the Clarifier sludge is as high as 46% . As such the sludge is thickened, dewatered using vacuum filters and then sent to the sintering plant, so that it can be fed back to blast furnace.

Metal Plating Waste

Introduction :

What is Metal Plating :

Plating is the application of a plate, or coat, of metal to a surface for decoration, reflection of light, protection against corrosion, or increased wearing quality. Electroplating is the most common method because it permits the control of the thickness of the plating. We offer: Gold, Nickel, Copper, and Chrome plating.

What is Electroplating :

Electroplating is the deposition of a metallic coating onto an object by putting a negative charge onto the object and immersing it into a solution which contains a salt of the metal to be

deposited. The metallic ions of the salt carry a positive charge and are attracted to the part. When they reach it, the negatively charged part provides the electrons to reduce the positively charged ions to metallic form.

After metals have been fabricated into the appropriate sizes and shapes to meet customer's specifications, they are finished to final product requirements. Finishing usually involves stripping, removal of undesirable oxides, cleaning and plating, the metal to be plated acts as the cathode, while the plating metal in solution serves as the anode.

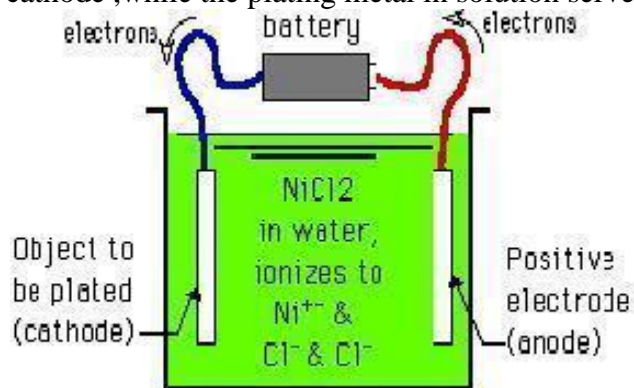

Imagine that we have an object that is made of copper or steel, and that it has been properly cleaned, and that we now want to plate it with nickel. A wire is attached to the object, and the other end of the wire is attached to the negative pole of a battery (the wire is blue in this picture). To the positive pole of the battery we connect the red wire; the other end of the red wire we connect to a rod made of nickel.

Now we fill the cell with a solution of a salt of the metal to be plated. It is theoretically possible to use a molten salt, and in rare cases that is done, but most of the time the salt is simply dissolved in water. The NiCl_2 ionizes in water to Ni^{++} and two parts of Cl^-

Because the object to be plated is negatively charged, it attracts the positively charged Ni^{++} . The Ni^{++} reaches the object, and electrons flow from the object to the Ni^{++} . For each atom of Ni^{++} , 2 electrons are required to neutralize it or 'reduce' it to metallic form.

Meanwhile, the negatively charged Cl^- ions are attracted to the positively charged anode. At the anode, electrons are removed from the Nickel metal, oxidizing it to the Ni^{++} state. Thus the nickel metal dissolves as Ni^{++} into the solution, supplying replacement nickel for that which has been plated out, and we retain a solution of nickel chloride in the cell.

We used nickel chloride as the first example here for a number of reasons, including simplicity. But we do not recommend that nickel be used for school science demonstrations because some people are quite allergic to it; and we do not recommend that chloride salts be used, because it is possible to release chlorine gas from them.

The plating process involves: (i) alkaline cleaning, (ii) acid pickling, (iii) plating, and (iv) rinsing. A copious amount of wastewater is generated through these steps, especially the rinse steps.

Additionally, batch dumping of spent acid and cleaning solutions contribute to the complexity of the treatment process.

Cleaning :

The materials to be plated when received in plating shop usually contain oils or greases on its surface given as a protection coating. They are removed by warm alkali. This process is also called as alkaline degreasing. The spent alkaline liquor have high pH , suspended solids and contains soaps, grease and oil. After degreasing the materials are given washing in stationary baths or in running water which are discharged continuously. The rinse and washing effluents are usually alkaline.

Stripping (Acid Pickling) :

It is a process usually carried on iron materials by which the rust and scales adhering to the metallic surface are removed by treatment with sulphuric or hydrochloric acid. The spent liquors are not discharged continuously. Though the volume of these spent liquors is much less, they are strong wastes, and causes serious effects.

The pickled or acid dipped materials are washed in vats with continuous flow of water. These wash and rinse waste waters are also acidic and their pH value lie in the range of 4.5 to 5.5

Plating :

The pickled materials are placed as Cathode in suitable electrolytic cells. The plating baths are usually acidic in nature and contain sulfuric, hydrochloric or nitric acids. Alkaline baths containing carbonate, hydroxide and cyanide are also used. Cyanides are used in plating baths as they are good oxide solvents and they yield a brighter and less porous plates.

After plating, the objects are dipped in stationary water baths, then rinsed with running water. The solution in the stationery water baths are not discharged as waste but utilized to make up solution for plating baths. The rinse waste waters are discharged as waste.

The total liquid wastes are not voluminous but are extremely dangerous because of their toxic content. The most important toxic contaminants are acids and metals such as chromium ,zinc ,copper ,nickel , tin and cyanides .Alkaline cleaners , grease and oil are also found in the wastes. There are two main sources of waste from plating operations ,each one distinctive in its volume and chemical nature:1.Batch solutions and 2.Rinse waters , including both non overflowing reclaimable rinses and continuous overflow rinses.

There are two main sources of waste from plating operations ,each one distinctive in its volume and chemical nature:1.Batch solutions and 2.Rinse waters , including both non overflowing reclaimable rinses and continuous overflow rinses.

Characteristics of Metal Plating Waste :

Most stripping waters are acidic in nature and consist of solutions of sulfuric , nitric and hydrochloric acid but alkaline baths containing sodium sulfide , cyanide and hydroxide may also be used.

The character and strength of plating wastes vary considerably depending on plating requirements and type of rinsing used. The total plant waste may be either acidic or alkaline , depending on the type and quantity of baths used.

Wastewater from metal plating facilities contains contaminants such as heavy metals, oil & grease, and suspended solid at levels which are considered hazardous to the environment and

could pose risk to public health. Heavy metals, in particular, are of great concern due to their toxicity to human and other biological life.

Wastewater from metal plating facilities contains contaminants such as heavy metals, oil & grease, and suspended solid at levels which are considered hazardous to the environment and could pose risk to public health. Heavy metals, in particular, are of great concern due to their toxicity to human and other biological life.

Effects of Effluents :

Effects on sewers :

Plating is the application of a plate, or coat, of metal to a surface for decoration, reflection of light, protection against corrosion, or increased wearing quality. Electroplating is the most common method because it permits the control of the thickness of the plating. We offer: Gold, Nickel, Copper, and Chrome plating.

Effects on streams :

Very small concentrations of cyanide , chromic acid and chromates, heavy metal compounds of cadmium , copper , lead , nickel and zinc are toxic to aquatic life . In high concentrations they are toxic to humans also. As they are toxic to microbiological and biological organisms self purification is inhibited. Further, iron and tin impart colour to the receiving stream. The colloidal and other suspended impurities render a bad appearance to the stream.

Treatment :

- Segregation of cyanide wastes, chromium effluents and other metal bearing wastes.
- Treatment of chromium effluents with ferrous sulfate or other suitable reducing agents to reduce chromium VI to chromium III and precipitation with lime.
- Mixing of treated effluents by cyanide and chromium with other metal bearing wastes followed by pH adjustment, precipitation at pH 8.5 to 9.0 and settling.

Treatment of Metal Plating Waste

The methods used for disposal of waste from plating operations can be divided into two classes:1.modifications in design and /or operation within the manufacturing process to minimize or eliminate the waste problem.2.installation of a chemical (physical)treatment plant to destroy or remove toxic and objectionable materials.

Treatment of plating wastes by chemical and physical means are designed to accomplish three objectives: removal of cyanides, removal of chromium and removal of all other metals, oil and grease.

The treatment of cyanides, although mostly accomplished by alkaline chlorination is being carried out by:1.chlorination gas, 2.hypochlorites 3.ozonation 4.acidification 5.ion exchange etc. Chromium bearing plating wastes are normally segregated from cyanide wastes and they must be reduced and acidified before precipitation.

The removal of other metals such as Cu, Zn, Ni, Fe and grease is usually accomplished by neutralization followed by chemical precipitation.

Oil Refineries Waste

Sources of Waste Water

Manufacturing Process :

Crude oils are complex mixtures of hydrocarbons of varying molecular weight and structure. These hydrocarbons range from simply highly volatile substances to complex waxes and asphaltic compounds. The final petroleum products are obtained from the crude oil through a series of operations viz. topping , thermal cracking , catalytic cracking , catalytic reforming etc. In general , the crude oil is first subjected to fractional distillation in the process known as " topping " . The products obtained are called raw products and include raw gasoline, raw naphtha , raw kerosene , gas oil, fuel oil etc.

Now these intermediate refinery products are again treated to yield various finished market products as per the requirements. The operations practiced include "catalytic cracking" or "thermal cracking" and further purification processes like "acid treatment" , "sweetening treatment" , "hydrodesulphurization" etc.

The decomposition of heavy or high boiling petroleum distillates like gas oil and fuel oil to lighter products like gasoline is called cracking. These operations take place practically at the atmospheric pressure and at a high temperature. In catalytic cracking, however, an acid type solid catalyst (such as synthetic silica alumina) is introduced into the reactor.

A residue of heavy black material known as coke, is obtained out of the process of cracking. In the catalytic cracking process, however , the asphaltic or tar-like products get adsorbed on to the surface of the catalysts in the form of coke.

When "high octane" fuels are in demand ,much of the naphtha is "catalytically reformed" into high octane gasoline; the process involved is another form of cracking.

The wax distillates of the crude oil may be used as raw material for the manufacture of light lubricating oils. The process of their manufacture consists of chilling the distillates and filtering the wax from the oil.

The products thus obtained either as final product or as feedstock for further processing may contain certain undesirable constituents which must be either removed or converted into less harmful compounds by further refining processes. Such refining processes include (i) removal of hydrogen sulfide gas and mercaptans by washing with strong caustic soda solution , or (ii) absorption of hydrogen sulfide gas in an alkaline absorber liquid followed by the recovery of the hydrogen sulfide gas , in the process known as regenerative process (iii) conversion of mercaptans to less harmful desulphide, employing solutions like lead oxide in caustic soda together with sulphur, or sodium hypochlorite or copper chloride , in a process known as "sweetening" and (iv) conversion of alkylsulphides and thiophenes and practically all other sulphur compounds into hydrogen sulfide in a catalytic in the process known as "hydrodesulphurization" - hydrogen sulfide thus formed is recovered by the regenerative process.

Fertilizer Plant Waste

Introduction :

Fertilizer industry can be divided into three main categories depending upon

1. Fertilizer raw materials
2. Fertilizer intermediates
3. Fertilizer products

Fertilizer Intermediates:

1. Sulphuric acid
2. Phosphoric acid
3. Nitric acid

Fertilizer products:

SOLID

N - Fertilizers

1. Ammonium nitrate
2. Urea
3. Ammonium sulfate

P - Fertilizers

1. Super phosphates NPK fertilizers

LIQUID:

Ammonia fertilizers produced in India can be classified broadly into two groups viz., nitrogenous fertilizers, and phosphatic fertilizer. Plants may be producing only nitrogenous fertilizers like urea, Ammonium sulphate, Ammonium Nitrate, Ammonium chloride or only phosphatic fertilizers like super phosphates; there are plants where complex fertilizers containing both nitrogen and phosphates like Ammonium phosphate and Ammonium sulphate phosphate are produced

Manufacturing Process :

Ammonia is the principal intermediate in the manufacture of all nitrogenous fertilizers. So, except when the byproduct ammonia will be available from a coke oven, raw materials for nitrogenous fertilizer production is the carbonaceous materials, which are required for making ammonia. So all the nitrogenous fertilizer plants will have essentially an Ammonia production unit and a reactor where the synthetic ammonia will be reacted with other chemicals to produce the final product. The plant may have auxiliary units to produce the reacting chemicals also. Basic process steps in the manufacture of urea, from carbonaceous raw materials like naphtha are as follows:

- (i) reaction of the carbonaceous materials with steam and air to form a mixture of hydrogen and carbon monoxide, known as synthesis gas.
- (ii) Reaction of the carbon monoxide with steam over a catalyst to form more hydrogen and carbon dioxide.
- (iii) Separation and purification of carbon dioxide.
- (iv) Removal of residual carbon monoxide from gas mixture

- (v) Synthesis of ammonia by reacting hydrogen and nitrogen over a catalyst (Nitrogen is supplied as air in an earlier step) and
- (vi) Synthesis of urea by treating ammonia with carbon dioxide in a reactor at higher temperature and pressure

- plants using by product Ammonia from other manufacturing plants (coke oven) have to produce carbon dioxide separately for the production of urea
- Ammonia sulphate may be produced by reacting Anhydrous Ammonia with Sulphuric Acid, usually obtained as by-product sulphuric acid from other manufacturing plants
- Ammonia sulphate may also be manufactured from Gypsum or from Calcium sulphate sludge obtained from the phosphatic fertiliser plant using Ammonia and CO_2 obtained from Ammonia plant. In this process calcium sulphate is reacted with Ammonia carbonate solution to produce ammonium sulphate.
- Ammonium nitrate is produced when ammonia is reacted with nitric acid. Normally the required quantity of nitric acid is produced in the same plant, by oxidizing the ammonia.
- Super phosphate is produced by merely mixing the phosphate ore (commonly known as phosphatic rock) with sulfuric acid to convert the phosphate to 'Monocalcium' phosphate. The by-product calcium sulphate of this process may be used in the manufacture of Ammonium sulphate.
- Ammonium phosphate is made by treating phosphoric acid with Ammonia, the phosphoric acid production process involves the following steps
 1. Dissolving phosphate rock in enough sulphuric acid
 2. Holding the mixture until the calcium sulphate crystals grow to adequate size.
 3. Separating the phosphoric acid and calcium sulfate by filtration and Concentration of acid to the desired level.

Treatment of Fertilizer Waste Water :

Major pollutants in the fertilizers waste water for which the treatment is necessary include oil, arsenic, ammonia, urea, phosphate and fluoride.

The effluent streams can be characterized as either a phosphoric effluent or an ammonia effluent. The phosphoric acid effluent is high in fluoride concentration, low in pH, High in phosphate and high in suspended solids. Standard practice has been contain the water for reuse, allowing enough time for solids sedimentation.

- Oil is removed in a gravity separator
- Arsenic containing waste is segregated and after its concentration the solid waste is disposed off in a safe place.
- Phosphate and fluoride bearing wastes are also segregated and chemically coagulated by lime; clarified effluent which still contains some amount of phosphate and fluoride is diluted by mixing with other wastes.

The other effluent type is characteristic of ammonia production and ammonia containing products. Most of the contamination comes from ammonia production itself. It is

characteristically high in ammonia from effluent gas scrubbing and gas cleaning operations and high in sodium hydroxide or carbonate from gas cleaning process.

Several alternatives are there for the treatment of Ammonia bearing wastes

1. Steam stripping
2. Air stripping in towers
3. Lagooning after pH adjustment
4. Biological nitrification and denitrification

For all practical purposes, steam stripping for the ammonia removal from fertilizer wastes have been found to be uneconomical.

Removal of Ammonia gas from the solution in an air stripping tower, packed with red wood stakes, is found to be very efficient method. Very encouraging results are obtained from some laboratory and pilot plant studies conducted by NEERI in the removal of Ammonia by simply lagooning the waste. It was found that considerable reduction in the Ammonia content can be accomplished just by retaining the Ammoniacal waste in an Earthen tank about 1m deep, for a day or two after a pretreatment of the waste by lime increase the pH to 11.0. Of course with urea containing waste, no reduction in urea content is observed within this period' Thus waste containing both urea and Ammonia required to be retained in the Lagoon for a longer period, to allow urea to decompose to ammonia first.

Biological nitrification involves oxidation of Ammonia to nitrate via nitrite under aerobic condition; this followed by the denitrification of the nitrified effluent under anaerobic condition; in which gaseous N_2 and N_2O is the end product and is released to the atmosphere. The denitrification requires addition of some quantity of carbonaceous matter in the reactor.

In all the Ammonia removal method described above, urea remain as untouched. If urea removal is required the urea containing wastes must be retained for a sufficiently long time in an earthen lagoon to allow it to decompose first to ammonia.

Waste Water from Fertilizer Plant:

A variety of wastes are discharged from the Fertilizer plant as water pollutants in the form of

1. Processing chemicals like Sulphuric acid
2. Process intermediate like Ammonium, Phosphoric and etc.
3. Final products like urea, Ammonium sulphate, Ammonium phosphate etc.

In addition to the above, oil bearing wastes from compressor houses of ammonia and urea plants, some portion of the cooling water and the wash water from the scrubbing towers, for the purification of gases, also come as waste.

Wash water from the scrubbing towers may contain toxic substances like Arsenic, Monoethanolamine, Potassium carbonate etc. in a Nitrogenous fertilizer plant, while that in a phosphatic fertilizer plant may contain a mixture of carbonic acid, hydrofluoric acid. Both alkaline and acidic wastes are also expected from the boiler feed water treatment plant, the wastes being generated during the regeneration of anion and cat ion exchanger units.

Additional pollutants like phenol and cyanide will be introduced in the list of pollutants in the fertilizer plant where ammonia is derived from the waste ammonia cal liquor of the coke ovens.

Average characteristics of the waste water from a typical Indian fertilizer plant producing both nitrogenous and phosphatic fertilizer is given below.

Parameter	Value
-----------	-------

pH	7.5to 9.5
Total solids, mg/l	5400 mg/l
Ammonia Nitrogen	700 mg/l
Urea Nitrogen	600 mg/l
Phosphate	75 mg/l
Arsenic	1.5 mg/l
Fluoride	15 mg/l

Effects of Wastes on receiving streams:

All the components of the waste from the fertilizer plants induced adverse effects in the stream. Acids and Alkalis can destroy the normal aquatic life in the stream. Arsenic, Fluorides and Ammonium salts are found to be toxic to the fishes. Presence of different types of salts renders the stream unfit for use as a source of drinking water in the downstream side. Nitrogen and other nutrient content of the waste encourages growth of aquatic plants in the stream.

Suger Mill Wastes

Introduction & Manufacturing Process

Introduction

In Countries like India, Cuba and Jamaica, the sugar is produced from sugar canes, while in many other places beetroots are used as the raw materials for the sugar production. In India most of the sugar mills operate for about 4 to 8 months just after the harvesting of the sugar canes

Manufacturing Process

The sugar canes are cut into pieces and crushed in a series of rollers to extract the juice, in the mill house. Juice is extracted from the sugar cane, leaving a fibrous residue called bagasse, which can be used as a fuel for the boilers or can be disposed of as solid waste. The milk of lime is then added to the juice and heated, when all the colloidal and suspended impurities are coagulated; much of the colour is also removed during this lime treatment. Lime is added to the extracted juice to raise its pH and to prevent the inversion of the sucrose molecule to glucose and fructose. The coagulated juice is then clarified to remove the sludge. The clarifier is further filtered through filter presses, and then disposed off as solid waste. The filterate is recycled to the process, and the entire quantity of clarified juice is treated by passing sulphur dioxide gas through it. The process is known as " sulphitation process"; colour of the juice is completely bleached out due to this process.

The clarified juice is then preheated and concentrated in evaporators and vacuum pans. The partially crystallized syrup from the vacuum pan, known as "massecuite" is then transferred to the crystallizers, where complete crystallization of sugar occurs.

The massecuite is then centrifuged, to separate the sugar crystals from the mother liquor. The spent liquor is discarded as "black strap molasses". The sugar is then dried and bagged for transport. The black strap molasses may be used in the distilleries.

Sources of Waste Water and the Characteristics of the Waste

Wastes from the mill house include the water used as splashes to extract maximum amount of juice, and those used to cool the rolling bearings. As such the mill house waste contains high B.O.D due to the presence of sugar, and oil from the machineries.

The filter clothes, used for filtering the juice, need occasional cleaning. The wastewater thus produced through small in volume, contains high B.O.D and suspended solids. A large volume of water is required in the barometric condensers of the multiple effect evaporators and vacuum pans. The water is usually partially or fully recirculated, after cooling through a spray pond. This cooling water gets polluted as it picks up some organic substances from the vapour of boiling syrup in evaporators and vacuum pans.

The water from spray pond when overflows, becomes a part of the wastewater, and usually of low B.O.D in a properly operated sugar mill. Additional waste originates due to the leakages and spillages of juice, syrup and molasses in different sections, and also due to the handling of molasses.

Characteristics of Sugar Mill Waste

Parameter	Value
pH	4.6- 7.1
C.O.D mg/	600 - 4380
B.O.D mg/l	300 - 2000
Total Solids	870 - 3500
Total Volatile Solids	400 - 2200
Total Suspended Solids	220 - 800
Total Nitrogen	10 - 40
C.O.D /B.O.D ratio	1.3 - 2.0

Effects of the waste on receiving streams :

The fresh effluent from the sugar mill decomposes rapidly after few hours of stagnation. It has been found to cause considerable difficulties when their effluent gets an access to the watercourse. The rapid depletion of oxygen due to biological oxidation followed by anaerobic stabilization of the waste causes a secondary pollution of offensive odour and black colour.

Treatment :

Disposal of the effluent on land as irrigation water is practical in many sugar mills, but it is associated with odour problem. The reasonable C.O.D/B.O.D ratio of the mill effluents indicate that the waste is amenable to biological treatment. However, generally it is found that, the aerobic treatment with conventional activated sludge process and trickling filter is not too efficient, even at a low organic loading rate. A max B.O.D reduction of 51% is observed in a pilot plant study at Kanpur, where both trickling filter and activated sludge process were tried. In view of the high cost of installation and supervision of the treatment units, and the seasonal nature of the operation of this industry, it is generally observed that the conventional aerobic treatment will not be economical in this country. Anaerobic treatment of the effluent, using both digesters and lagoons, have been found to be more effective and economical.

A B.O.D reduction of about 70% was observed in a pilot plant study with an anaerobic digester. The effluents of the anaerobic treatment units are found to contain sufficient nutrients (nitrogen and phosphorous). As such further reduction of B.O.D can be accomplished in aerobic waste stabilization ponds. Where sufficient land is available, a two stage biological treatment, with anaerobic lagoons followed by aerobic waste stabilization ponds, is recommended for Indian conditions. The mill effluent however is to be pretreated primarily in bar screens and grease trap.

It is expected that the B.O.D reduction in the anaerobic process will be in the order of 60%, while overall B.O.D reduction may be in the order of 90%.

Fermentation

Introduction & Manufacturing Process

The Fermentation industries include breweries and distillery manufactures of alcohol and certain organic chemicals and some parts of the pharmaceutical industry such as producers of antibiotics.

Fermentation has been defined as the decomposition of the complex organic substances into material of simpler composition, under the influence of nitrogenous organic substances called ferments.

The transformation of grape juice into wine, the manufacture of alcohol from molasses, and the use of yeast in dough to make bread are familiar examples of fermentation.

Two main types of raw material are used for producing alcohol or alcoholic products, starchy materials such as barley, oats, rye, wheat corn, rice and potatoes and materials containing sugars such as black strap and high sugar molasses, fruits and sugar beet.

The process of converting these raw materials to alcohol varies somewhat depending on the particular raw material and the desired alcoholic product. For instance, flavour is of prime importance in the manufacture of beer, and this concern accordingly influences the process used. Manufacturers of distilled products, on the other hand, are more concerned with alcohol yield.

Sugar Beet: The process of converting these raw materials to alcohol varies somewhat depending on the particular raw material and the desired alcoholic product. For instance, flavour is of prime importance in the manufacture of beer and this concern accordingly influences the process used. Manufacturers of distilled products on the other hand are more concerned with alcohol yield.

The process of Brewing and distilling consists of :

1. Conversion of malt to finely divided state in a malt mill.
2. Preparation of the mash by mixing malt with hot water and in some cases with raw grain.
3. Transformation of starches to sugar by the action of malt.
4. Draining and washing the sweet water from the mash to fermentation tanks.
5. Fermentation of sugars to alcohol by yeasts.
6. Cooling, Skimming and clarification of the fermented liquor.
7. Locking in casks (if used for beer); storing in vats (if used for alcohol).

Origin of Brewery, Distillery and Winery waste

The brewing of beer has two stages: Malting of barely and brewing the beer from this malt. Both these operations are carried on in the same plant. The malting process consists of the following steps:

1. Grain is removed from storage and screened.
2. Screened grain is placed in the tank and steeped with water to bleach out the color.

3. Grain is then allowed to germinate while air and water are introduced to stimulate growth of enzymes to be used for inoculum.
4. The grain malt is removed after 5 – 8 days of aeration to the dryer where it is dried for about 4 days to predetermined moisture content.
5. The finished malt, after the sprouts have been screened out is stored and aged in large elevators.

Prepared By: **Mr. SRINIVAS ANGADI,**
ENGINEERING
Assistant Professor,
Department of CIVIL Engineering

HOD, CIVIL