



Government  
of South Australia

SafeWork SA



# INDUSTRY GUIDE FOR FORMWORK

CONSTRUCTION INDUSTRY SOUTH AUSTRALIA

JUNE 2012

# INDUSTRY GUIDE FOR FORMWORK



## Acknowledgments

This guidance material has been developed by a tri-partite industry working party and has involved extensive consultation with industry and other special interest groups. The contribution of the following organisations is acknowledged:

- Built Environs Pty Ltd
- Construction, Forestry, Mining and Energy Union
- Hansen Yuncken Pty Ltd
- Hindmarsh Australia
- Mitcon Formwork Pty Ltd
- Newgen Formworkers
- System Formwork Pty Ltd
- SafeWork SA

## Diagrams courtesy of:

- Bovis Lend Lease
- Workplace Health and Safety Queensland
- SafeWork SA

## Photographs courtesy of:

- Construction, Forestry, Mining and Energy Union
- Mitcon Formwork Pty Ltd
- System Formwork Pty Ltd
- Hindmarsh Australia

## Disclaimer

Information provided in this publication has been prepared by industry representatives and is designed to prevent injury to anyone engaged in erecting and dismantling formwork and associated equipment.

This publication is correct at the time of printing and is provided as general information only. In utilising general information about workplace health and safety, the specific issues relevant to your workplace should always be considered.

There may be additional risks at a workplace that have not been specifically addressed in this guidance. Under the South Australian occupational health and safety laws, such risks must be identified and control measures implemented and reviewed to eliminate or minimise exposure to these risks.

Users of this guidance material should be aware that it is based on current knowledge and construction methods within the industry and is not intended to exclude other methods or processes that can also meet the required safety standards. This industry guide, on any particular aspect of legislation, is not to be taken as a statement of law. To ensure compliance with your legal obligations you must refer to the relevant Acts, Regulations and Approved Codes of Practice. This publication may refer to legislation that has been amended or repealed. When reading this publication you should always refer to the latest laws.

# PREFACE

This Industry Guide for Formwork is based on the South Australian *Occupational Health, Safety and Welfare Regulations 2010*. Given that South Australia is likely to adopt the harmonised legislation, it is recommended that readers of this document also become familiar with the requirements of the Work Health and Safety (WHS) legislation once it comes into effect.

SafeWork SA, in collaboration with members of the Construction Industry, has produced this guidance to provide employers, self-employed, and employees with practical advice on preventing injury to anyone engaged in erecting and dismantling formwork and associated equipment.

As part of the SA Construction Industry OHS Committee's strategy to address areas of high risk, it was agreed that the creation of appropriate industry guidelines for erecting and dismantling formwork and associated equipment was a priority.

It was further agreed that the codes of practice and guidelines, existing in other states (Queensland, New South Wales and Victoria) and operating effectively, could be utilised in the development of a similar resource for South Australia.

## The objectives of this industry guide are to:

- **give practical advice about ways to manage exposure to risks associated with work involving the assembly, erection, alteration and dismantling of formwork**
- **contribute to the development of consistent high standards for safe work in the construction industry that are conducive to best practice at the workplace.**

**It is not intended that this guide be applied to single-storey housing.**

# CONTENTS

<b>1. Introduction</b>	<b>4</b>		
1.1 Falls from height – limitations of harness systems for formwork activity	4		
<b>2. Design</b>	<b>5</b>		
2.1 Safe design of buildings in relation to formwork	5		
2.1.1 'Buildability'	5		
2.1.2 Materials	5		
2.2 Formwork systems	6		
2.2.1 Safe formwork design and verification	6		
2.2.2 Formwork design certification requirements	6		
2.2.3 Documentation	7		
2.2.4 Design variations	8		
2.2.5 On-site coordination and verification	8		
<b>3. Coordination and administration</b>	<b>9</b>		
3.1 Work program	9		
3.2 Housekeeping – access and storage	9		
3.2.1 Access and egress	9		
3.2.2 Material storage	9		
3.2.3 Rubbish storage and removal	9		
3.2.4 Storage to minimise manual task risks	9		
3.3 Training	10		
<b>4. Work systems</b>	<b>10</b>		
4.1 Formwork erection – traditional systems	10		
4.1.1 Foundations	11		
4.1.2 False deck	11		
4.1.3 Erecting frames	11		
4.1.4 Installing bearers	12		
4.1.5 Installing joists	12		
4.1.6 Fall protection from the formwork deck	12		
4.1.7 Edge protection on the formwork deck	13		
4.1.7.1 Formwork construction zone physical barriers	13		
4.1.7.2 Edge protection on completed decks	13		
4.1.8 Laying a formwork deck	13		
4.1.8.1 Getting started – safe access	13		
4.1.8.2 Typical work system for a leading edge	15		
4.1.8.3 Laying a form ply deck	15		
4.1.8.4 Laying a metal deck	16		
4.1.9 Cantilever requirements	16		
4.1.10 Penetrations	16		
4.1.11 Working zones for form workers and others	17		
4.1.12 Changing floor levels	18		
4.2 Formwork erection – modular formwork systems	18		
4.2.1 Basic modular systems	18		
4.2.2 Training	18		
4.3 Stripping formwork	18		
4.3.1 General formwork stripping	18		
4.3.2 Safe work method statements	18		
4.3.3 Certification prior to stripping	19		
4.3.4 Exclusion zone	19		
4.3.5 Drop stripping	19		
4.3.6 Bond reduction	19		
4.4 Crane and other load handling systems	19		
4.4.1 Loading materials during formwork construction	19		
4.4.2 Slinging loads	19		
4.4.3 Lifting gear	20		
4.4.4 Lifting formwork materials	20		
4.4.5 Lifting lugs	20		
4.5 Use of ladders	20		
<b>5. Special requirements for wall and column forms</b>	<b>21</b>		
5.1 Bracing for wind loading	21		
5.2 Access platforms	21		
5.3 Lifting methods	21		
<b>6. Special requirements for slip forms and jump forms</b>	<b>22</b>		
6.1 Access and egress	22		
6.2 Work platforms	23		
6.3 Trailing screens and platforms	23		
6.4 Climbing the form	23		
6.5 Training	24		
6.6 Health issues and amenities	24		
6.7 Engineering issues	24		
6.8 Emergency issues	25		
<b>7. Falling objects</b>	<b>26</b>		
7.1 Hazard controls	26		
7.2 Prevent the object from falling	26		
7.3 Perimeter containment screens	26		
7.3.1 Screen height at building step-ins	26		
7.3.2 Perimeter screen gaps	27		
<b>8. Health concerns</b>	<b>27</b>		
8.1 Noise	27		
8.2 Dust and atmospheric contaminants	28		
8.3 Manual tasks	28		
<b>APPENDICES</b>	<b>29</b>		
<b>Appendix 1: Definitions</b>	<b>29</b>		
<b>Appendix 2: Training</b>	<b>30</b>		
<b>Appendix 3: Sample engineer's certification letters</b>	<b>31</b>		
<b>Appendix 4: Construction checklist</b>	<b>33</b>		
<b>Appendix 5: Sample structural (pre-pour) certificate</b>	<b>34</b>		
<b>Appendix 6: Defects commonly found in formwork systems</b>	<b>35</b>		

# 1. Introduction

Formwork is the surface, supports and framing used to define the shape of concrete until the concrete is self-supporting (see *AS 3610-1995 Formwork for Concrete*).

For the purposes of this guide, the formwork assembly includes:

- the forms on which concrete is poured
- the supports to withstand the loads imposed by the forms and concrete
- any bracing added to ensure stability.

Hazards associated with the erection, alteration or dismantling of formwork include:

- falls from height
- falling objects
- formwork collapse (before, during and after pouring of concrete)
- slips and trips
- noise
- dust
- manual tasks
- sharp edges on metal decks
- sun glare.

To properly manage risks, a person must:

- identify hazards
- assess risks that may result because of the hazards
- decide on control measures to prevent, or minimise, the level of risk
- implement the control measures
- monitor and review the effectiveness of those measures.

Control measures must be implemented in an order of priority and before work commences. Figure 1 below illustrates the hierarchy of controls which represents the order of priority for controls where there is a risk that a person could fall.

## 1.1 FALLS FROM HEIGHT – LIMITATIONS OF HARNESS SYSTEMS FOR FORMWORK ACTIVITY

When erecting, altering or dismantling formwork, the use of the following systems is **not recommended**:

- travel restraint harness systems to prevent a fall
- fall arrest harness systems to arrest a fall.

**Travel restraint harness systems** are impractical for formwork as:

- the contour of the leading edge is constantly changing, requiring the length of the travel restraint line to be continually adjusted
- multiple lanyard anchorage points may be required
- the greater the number of workers building the formwork deck, the greater the likelihood of lines becoming tangled.

**Fall arrest systems** are prohibited under the South Australian *Occupational Health, Safety and Welfare Regulations 2010* (OHSW Regulations) in situations where there is insufficient distance available to prevent a person hitting an object, the ground or another surface, other than a vertical surface. For example:

- When erecting, altering or dismantling formwork, there may be insufficient free fall distance underneath the working area, resulting in a falling person striking the ground, a frame or other obstruction prior to the fall being arrested.
- A falling person may require a free fall distance in excess of 6 m for the fall to be safely arrested by a harness system. In some situations, this distance can be substantially reduced by the use of shorter lanyards and/or higher anchorage points.
- The anchorage point design load required for fall arrest systems is relatively high. The OHSW Regulations specify that each anchorage point of the system must have a minimum capacity of 15 kN for one person free-falling.
- The erection of formwork frames using fall arrest harnesses requires the user to regularly disconnect from and reconnect to anchorage points, requiring the use of a double lanyard.

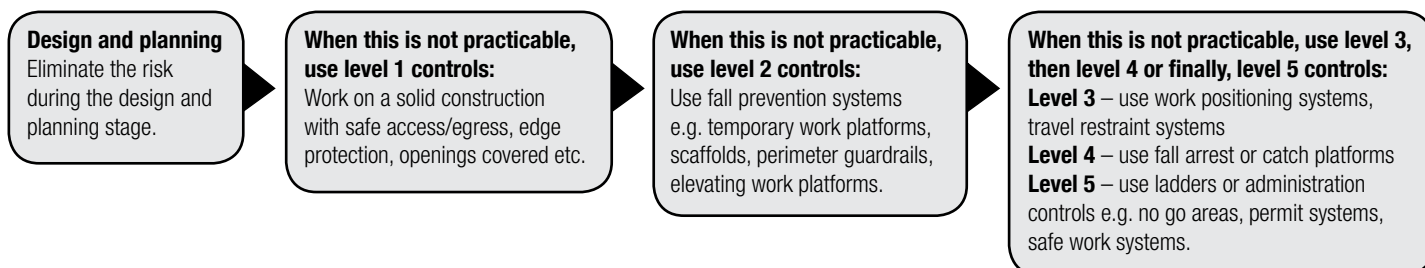

Figure 1 Hierarchy of controls – Controlling the risk of falls

### Consider the following before using a harness system:

- A risk assessment addressing the hierarchy of controls should be used to identify satisfactory alternatives to a harness – based on fall prevention measures.
- Implementing the use of solid work zone barriers is one effective engineering solution. Refer to section 4.1.7 of this guide for further information.
- Training is required before a person uses a harness. For training requirements under the South Australian *Occupational Health, Safety and Welfare Act 1986* (OHSW Act), please refer to Appendix 2.

## 2. Design

Under section 23a 'Duties of designers and owners of buildings' of the OHSW Act, designers of buildings to be used as workplaces have obligations for workplace health and safety.

### 2.1 SAFE DESIGN OF BUILDINGS IN RELATION TO FORMWORK

#### 2.1.1 'Buildability'

Building designers, including engineers and architects, must consider the 'buildability' of a structure or building with the objective of producing a design that minimises the risk of injury during construction.

The design of the final concrete structure may have a major effect on the ease of formwork construction and consequently, on the safety of people during construction. Generally, a more basic and simple final concrete structure is safer to erect.

A formwork designer should be consulted during the design of any building to provide input on ways to minimise the risk of injury arising from formwork activities.

The following design measures could be considered to minimise exposure to risk of injury during the construction of formwork:

- Reduce variations in the floor depth i.e. construct a floor so that it has one consistent depth. Decks that are a consistent depth are easier to erect than variable depth floors and reduce the risk of injury. Deeper beams introduce 'drop downs' into the floor, creating trip and fall hazards, and require more work to construct and strip after pouring.
- Where beam forms are essential, lightweight temporary access across the beam recess must be provided to prevent injury to workers from stepping into the form during construction (see Figure 2 above).
- Reduce the number of columns required and where columns do exist, eliminate capitals and dropdowns.
- Utilise precast columns and beams. This can reduce the risks associated with fixing reinforcement, erecting and stripping column formwork and pouring concrete on-site. Work activities carried out in a factory environment are generally lower risk.

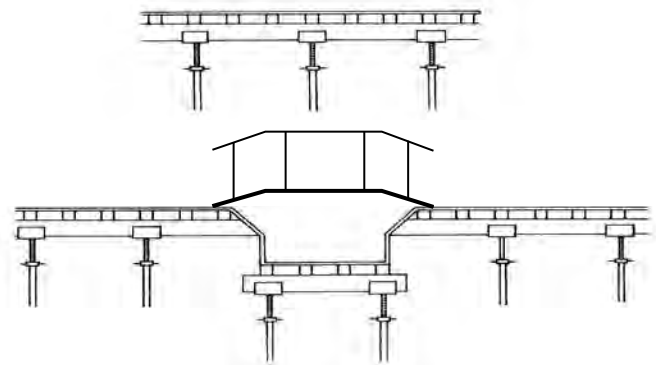

Figure 2 – Flat floor and temporary access as fall protection for deep floor beams

- Reduce cantilevered floor sections.
- Plan for manual tasks. Consideration should be given to the suitability of the design of different formwork systems that will reduce manual handling risks such as:
  - table forms
  - systems with lighter weights of materials to be handled
  - methods of formwork erection, alteration and dismantling
  - improved access and egress for workers and movement of materials and equipment
  - methods for moving large and heavy components, materials and equipment i.e. making allowances for a crane and other mechanical lifting devices to be used.

#### 2.1.2 Materials

All materials and equipment used in formwork construction must be fit for the intended purpose, meet design specifications and be designed to conform to relevant Australian Standards. Equipment must be manufactured in accordance with a quality assurance system that ensures compliance with the design specification.

Evidence verifying that form ply sheets and timber bearers conform to Australian Standards should be kept on-site. Such evidence may include:

- a purchase order which details the specifications of the form ply sheets ordered
- form ply sheets being marked in accordance with Australian Standards (see *AS/NZS 2269.0:2008 Plywood-Structural-Specification*).

If alternative products, other than timber are used, an engineer should verify that they are adequate for purpose.

## 2.2 FORMWORK SYSTEMS

In Australia, formwork systems are generally designed to:

- *AS 3610 – Formwork for Concrete*
- *AS 3600 – 2009 Concrete Structures*.

### 2.2.1 Safe formwork design and verification

A designer of formwork, either a formwork designer or an engineer (see Appendix 1 for definitions), is responsible for overseeing the safe design of the complete formwork structure. This includes design of the formwork support structure, the formwork deck and connection details.

When specifying the design of the formwork system, a formwork designer must allow for all expected loads applied during the three phases of construction i.e. during formwork erection, during concrete pouring and after concrete pouring is complete until the structure is self-supporting. This includes loads applied by:

- the formwork deck, supporting members and formwork frames
- any false decks that may be provided
- concrete pouring techniques (i.e. concrete skip or pump)
- the concrete pour, which includes both the weight of the concrete and dynamic factors applied, including the concrete pour rate and pour sequence
- workers on the formwork deck and false decks
- stacked materials
- crane-lifted materials on both the complete and incomplete formwork deck
- environmental loads, including forces due to water flowing around the formwork. Rain and run off can have a detrimental effect if not considered by a designer
- wind, as detailed in *AS 1170.2:2011 Structural Design Actions – Wind Actions*:
  - wind loading will vary depending on:
    - the size of form
    - the nature of the form
    - wind speed
    - wind resistance (e.g. screens)
    - wind direction
  - wind loading on vertical forms, particularly for external walls, columns, freestanding shutters, blade walls and any platforms that may be subject to uplift
  - vertical elements should be fully braced prior to and during stripping until such time as the construction provides adequate support against wind loading
  - shade cloth used on screens, signage and outside screens will increase the effective wind loading of an open structure

- the geographical location of the construction site will have a bearing on the severity of wind on the structure. Wind generally has less effect in built up or hilly areas
- *AS 1170.2 Structural Design Actions – Wind Actions* specifies four different terrain categories that should be taken into consideration by a formwork designer as well as basic wind speeds for different zones in Australia [practically all areas of South Australia fall under Region A (normal)].

Refer to section 4 'Structural Design and Documentation' of *AS 3610 Formwork for Concrete* for further details on formwork load calculations.

### 2.2.2 Formwork design certification requirements

This guide considers two types of formwork systems: **basic** and **non-basic**. A formwork designer may certify a basic formwork system, whereas only an engineer may certify a non-basic formwork system.

While this guide recommends that only an engineer may certify a non-basic formwork system, it is recognised that a competent person experienced in formwork design and documentation, such as a formwork designer, may perform the majority of the design work.

For both basic and non-basic formwork systems, certification should confirm that the formwork meets the requirements of *AS 3610 – 1995 Formwork for Concrete* and the construction drawings. This certification should also confirm that other formwork and project documentation detailed in sections 2.2.3 of this guide, have been completed as required for the project. Sample engineer's certification letters are provided in Appendix 3.

#### Basic formwork systems

For the purposes of this guide, a basic formwork system is the formwork for a floor, wall or column and includes:

- standard formwork frames which have a known tested loading capacity and are spaced at no more than the recommended distances apart for a normal floor thickness with bearers, joists and form board on top of them
- specially manufactured and designed formwork systems with proprietary formwork components and rated load calculations in line with the manufacturers' specifications.

A basic formwork system is limited by the following conditions:

- the height of the formwork may be up to a maximum of 6 m to the soffit of the new floor from the supporting floor
- walls and columns may not be greater than 6 m free standing from the floor on which the formwork will be supported to the top surface of the concrete
- any back-propping is excluded from basic formwork systems and is to be certified by an engineer.

Either a formwork designer or engineer may certify a basic formwork system. Where any of these conditions are exceeded or back-propping is involved, the system is to be classified as a non-basic formwork system and must be certified by an engineer.

### **Non-basic formwork systems**

Formwork systems that exceed the description of a basic formwork system are, for the purposes of this guide, categorised as non-basic formwork systems. For the purposes of this guide, only an engineer may certify:

- the design of any temporary or permanent formwork structures categorised as non-basic formwork systems
- any back-propping used for either basic or non-basic formwork systems.

Non-basic formwork systems include formwork structures for any floor, wall or column higher than 6 m, or three frames, or three times the least base width of the scaffold.

### **2.2.3 Documentation**

The extent of documentation required for any structure may vary depending on the complexity of the formwork and supporting structure design and the conditions in which it is to be constructed. The documentation requirements outlined below are provided as a guide only, for situations where there is a complex construction process at height, that is considered to be high risk. It is expected that some elements of documentation may be reduced or omitted for some more basic and lower risk construction applications.

#### **Formwork drawings**

Formwork drawings explain the general arrangement of the formwork plans, elevations and sections, identifying and locating all members and components including bracing.

An engineer should nominate the following on the drawings or other documentation:

- maximum allowable point loading to be applied and any additional propping requirements at any specific loading area
- component types and spacing
- maximum jack extensions
- bearer and joist timber type, dimensions and spacing
- prop sizes and maximum extensions
- methods for tying the structure together and spacing between ties (if required)
- form ply size, thickness and grade.

Where eccentric loading is to be applied to 'U-heads' (i.e. single bearers are positioned to one side of the U-head), the formwork drawings must state that this is permitted.

### **Other formwork documentation**

The following information should be included in the formwork documentation:

- any necessary preparation of the foundation such as filling, compaction and drainage
- any footing design assumptions, such as foundation material description, safe bearing values, limitations on settlement during erection of formwork, placement of concrete and dismantling of formwork. Reference to information sources such as geotechnical reports may also be included
- footing details, such as type and size of footings, level of soffit, concrete mix design strength, reinforcement, specification and details of site filling or compaction, and precautions against washouts
- sufficient details to fully describe important or unusual features of the formwork system design, including design assumptions, particularly those relating to strength, stability and stiffness
- the areas of the forms designed to carry stacked loads, together with the maximum allowable load, and the minimum strength of concrete to be achieved prior to materials being stacked
- Safe work method statements addressing:
  - the erection and stripping of the formwork assembly
  - methods for securing single or multiple props
  - methods for field adjustment of the forms prior to and during concrete placement
  - vertical pour rates in metres rise per hour, including the risks and implications of exceeding vertical pour rates
  - sequence of concrete placement, including direction of intended pour on raking or sloping surfaces (e.g. car park ramps and minimum elapsed time between adjacent placements)
  - wrecking strips and other details relating to stripping of the forms
- certification of non-proprietary equipment
- reference to documentation for proprietary items
- where required, location of weep holes, vibrator holes, clean-out holes and inspection openings
- acceptance criteria for single use formwork.

### **Project documentation**

Other project documentation should include the following information:

- details of fall and edge protection i.e. perimeter scaffolding
- location of any mandatory joints and any special procedures for locating other joints
- details of any inserts, water stops, specially formed shapes or penetrations to be constructed, the location and details of which are critical to the serviceability of the permanent structure
- information on any architectural or structural component details to be cast into the structural concrete



- details of the cambering of any slabs or beams
- information about any permanent formwork systems, together with limitations on deflections and any special requirements for their erection and concreting
- limitations on the use of the permanent structure for the restraint of formwork
- minimum stripping strength or times, stripping procedures and requirements for health and safety
- detailed information on the effect of pre or post-tensioning procedures on the formwork and any special procedures to be adopted in the stripping of formwork
- details of back-propping that may be required and minimum time intervals between concrete pours, including requirements for propping of any composite construction
- requirements for the minimum number of levels of supports relative to the type of formwork, the timing and sequence of floor propping, and the anticipated time between construction of subsequent floors for multistorey structures.

#### 2.2.4 Design variations

All formwork system design variations must be checked by a formwork designer for a basic system, or an engineer for a non-basic system. The variations must be certified (in writing) as complying with *AS 3610 – Formwork for Concrete* or whether they need to be altered in accordance with written directions to comply with *AS 3610*.

Potential variations may include:

- the number of formwork frames under the formwork deck
- types and number of braces or props other than indicated on the formwork drawing
- types and/or quantities of ties on the formwork structure
- spans on members supporting the formwork deck
- back-propping systems specified by an engineer
- connections between traditional formwork and modular formwork.

#### 2.2.5 On-site coordination and verification

Complex projects require constant and vigilant coordination by an experienced management and supervisory team. With properly scheduled and coordinated activities, sub-contractors are able to carry out the work in an orderly, safe, and more productive way.

Effective coordination and technical accuracy also require that formwork, project and variation documentation are readily accessible on-site.

When effective site coordination is not implemented or a construction team does not have access to essential technical information, the potential for failure increases.

### Verification of the formwork structure

An effective quality control system must be implemented for the construction of formwork. The system should ensure that:

- materials and components used on-site comply with the formwork design specifications, drawings and documentation
- damaged or excessively worn materials and components are not used, but are identified and sent off-site for repair or are destroyed.

The formwork structure's compliance with its design must be verified and documented. A construction checklist may be used as a guide for this process (refer to Appendix 4 for a sample checklist). However, relying solely on a checklist does not necessarily verify compliance with relevant Australian Standards.

The design verification and documentation process may be delegated to a 'competent person' who, if not an engineer or formwork designer, must have the experience, training and knowledge to perform on-site inspections of the formwork system (refer to Appendix 1 for definitions).

The competent person must be:

- experienced in formwork construction
- competent in interpreting drawings
- able to certify that the formwork structure satisfies the details on the formwork drawings, specifications and any other formwork documentation.

Should the competent person on-site not be a formwork designer or an engineer, the competent person:

- may only verify that the formwork structure complies with the designer's specifications and drawings
- may not authorise variations to the design
- must provide any construction checklist referrals to an engineer in writing
- must provide written instructions to the formwork supervisor for any remedial actions that need to be made to the formwork system prior to the concrete pour
- must ensure that any remedial action required has occurred prior to the concrete pour, including any items referred to an engineer.

Pre-pour inspection must focus on such matters as:

- the latest version of structural and formwork arrangement drawings and details submitted
- correct spacing of frames, props and timbers
- correct joist and bearer sizes, and loading
- acceptable jack extensions
- adequate bracing to ensure stability.

Pre-pour inspections are the last reasonable opportunity to ensure compliance with the formwork design specifications. Such inspection records form an important part of the site quality control system and must be signed-off by an engineer, formwork designer or competent person following the final pre-pour inspection. A sample pre-pour structural inspection certificate is provided at Appendix 5.

### Common defects in formwork systems

Appendix 6 illustrates some of the more common defects that are likely to occur in a formwork system. The list is intended to

give guidance to a competent person and is not considered to be exhaustive. In any individual case, the importance of items may vary and only a competent person can assess their relative importance.

## **3. Coordination and administration**

### **3.1 WORK PROGRAM**

The risk to a person's health and safety must be considered when designing a work program for erecting, altering or dismantling formwork. Consideration should be given to:

- edge protection requirements and ensuring these are designed and constructed in a timely manner to be safe to use
- sequencing work to ensure that sufficient time and resources are allowed for each work activity
- coordinating trades to allow work to be completed free from obstruction.

### **3.2 HOUSEKEEPING – ACCESS AND STORAGE**

Formwork construction results in a constantly changing work environment, with restricted access through frames and formwork supports, often with large volumes of material and waste. For this reason, it requires ongoing monitoring of housekeeping practices to maintain a safe and productive workplace.

Include housekeeping as an essential aspect of every job whether it be through work instructions, regular inspection of the workplace, or site/task induction training. Instructions should include time and resources for the progressive clean up of work areas to prevent rubbish and redundant materials from becoming a trip hazard and to allow safe access for mechanical aids.

#### **3.2.1 Access and egress**

The OHSW Regulations require that there be clear access to and from the workplace in accordance with Division 1 – Access and egress.

Clear access is important for the safe movement of materials, equipment and anyone on-site. Designated access ways should be provided and anyone on-site should be directed to use them. Access ways must be kept clear of any rubbish, plant or materials.

In some situations, green hazard taping/bunting or other visual methods can clearly show where access ways are located. This is particularly important where access is required through formwork frames.

Emergency access and egress must be provided to all parts of the workplace. The following situations should be considered:

- stretcher access and egress
- people carrying tools and equipment
- use of stairs
- provision of two means of egress at all times.

#### **3.2.2 Material storage**

The OHSW Regulations require safe stacking and storage of plant and materials at a workplace, as detailed in Division 15 – Storage.

Materials must be stored in a way that minimises manual task hazards, trip hazards and the potential for hazards from falling objects. Smaller components such as U-heads, couplers, base plates and 'Z-bars' should be stored in labelled material boxes, marked with safe load limits (SLL).

Where practicable, frames, form ply sheets, bearers and joists should be strapped in bundles or stacks and be located away from the edge of the deck, to prevent materials or anyone accessing them from falling.

Wall forms should be stacked in such a way that they cannot slide, or rotate away from the surface they are placed against. An engineer should verify, in writing, that a surface to be used for stacking forms is capable of withstanding the impact of all imposed loads, including wind loading. If purpose-made 'A-frames' are not available for storing wall forms when not in use, it is preferable to lay them flat on the ground, rather than leaning them against other structures. Timbers, or other effective means of support, should be used under forms where slings are to be used for lifting.

#### **3.2.3 Rubbish storage and removal**

Rubbish storage and removal for formwork may include the provision of rubbish skips and wheelbarrows that are moved as work progresses. However, rubbish skips may only be positioned where the supporting structure has adequate strength to support the total weight of the bin and its likely contents.

#### **3.2.4 Storage to minimise manual task risks**

Incorrect material delivery and storage practices can create significant manual handling risks. Safe work practices that can assist in minimising these risks include:

- ensuring that formwork materials are delivered as close as practicable to the job
- designing and designating a small section of the formwork deck as a loading platform for ply and other components
- ensuring mechanical aids are used to handle loads wherever possible
- storing loads on trolleys to minimise double handling, or on raised platforms to minimise manual lifting from ground level
- having an adequate storage space or lay down areas to safely store materials/equipment and to minimise double handling.

### 3.3 TRAINING

Anyone who may be exposed to workplace health and safety risks resulting from formwork construction must be provided with information and training that is specific to the formwork system that is being used. Training and information should include details of:

- the formwork system, components, tasks and activities
- the way the manufacturer or designer of the formwork system intended it to be erected, installed, used, moved, altered or dismantled
- the range of hazards associated with the formwork system, control measures to minimise exposure to the risks, the correct use of controls and how to ensure controls are maintained
- any special requirements to undertake or participate in specific tasks or activities
- any safe work method statements, including the use of mechanical aids and devices
- the use and maintenance of equipment, including any specific conditions and prohibitions on its use. Where necessary, reference should be made to operator's manuals
- any special safety information needed, such as safety precautions for working under certain conditions including hot work or confined space work
- personal protective equipment requirements, including instructions for fitting, use, cleaning, maintenance and storage
- the availability and content of this industry guidance document.

For training details refer to Appendix 2.

## 4. Work systems

### 4.1 FORMWORK ERECTION – TRADITIONAL SYSTEMS

The OHSW Regulations describe what must be done where there is a risk a person could fall in Division 13 – Prevention of Falls. The legislation also requires that a hazard identification and risk assessment be conducted and, where necessary, safe work method statements documented.

Formwork activities must comply with regulatory requirements for the erection of scaffolding. Formwork, like scaffolding, must be erected safely and systematically, and be tied in progressively to stabilise the structure.

A person must be provided with a working platform at least 450 mm wide (i.e. two planks) even when the potential fall distance is less than 2 m. It is not acceptable for a person to work from a single plank or bearer.

Irrespective of which framing system is used, workers must always use working platforms that are two planks wide as a minimum. Where a person is to install joists, this can be achieved using a two-plank work platform from underneath, allowing the vertical distance between the formwork deck and the false deck to be increased. This is illustrated in Figure 3 below.

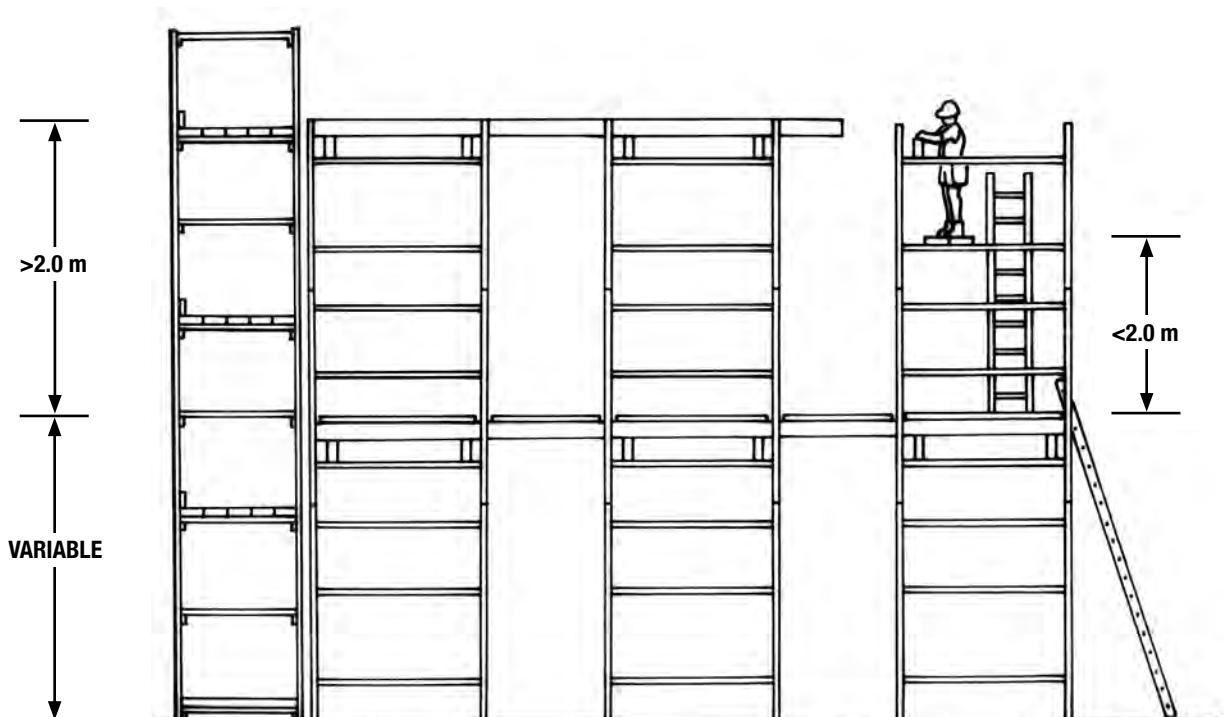

Figure 3 – Worker erecting formwork on two planks

#### 4.1.1 Foundations

Formwork must be erected on a stable base to prevent the risk of collapse. Suspended slabs must be able to safely support loads that may be applied by the concrete pour, workers and crane-lifted loads etc.

Base plates must be provided under props and standards on formwork frames unless the prop or standard has an integral foot, or an engineer documents that a base plate is unnecessary.

Sole boards designed to suit the ground conditions must also be used under props and standards on natural ground, unless an engineer states otherwise. Frames and props must be located on a sound base that will not subside, fail or wash away. The principal contractor is responsible for providing all information on ground conditions to the engineer or formwork designer.

#### 4.1.2 False deck

In situations where a deck is being installed at a height that would require a person to stand at a height of 2 m or more to install bearers and joists, a continuous 'false deck' should be provided (see Figure 4 below). This is a full deck that is the same area as the floor being formed but up to 2 m below the true deck. As indicated in section 4.1 above, the distance between the false deck and the true deck can be increased where a work platform is used. However, the fall distance from the work platform to the false deck must not exceed 2 m.

The false deck should be continuous both inside and between formwork frames and typically consists of form ply, scaffold planks or modular platform sections. A protected access opening can be left in the deck for lifting in materials.

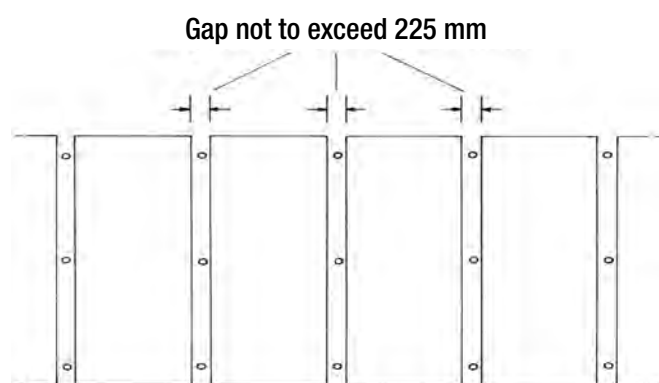

Figure 4 – A false deck

The use of a captive platform is preferable to lapped planks because a captive system cannot be accidentally dislodged and its construction also minimises trip hazards. Lapped planks may only be used if they are secured against uplift and slippage. The false deck should be constructed such that no gap exceeds 225 mm in width and gaps only exist where a vertical member of a frame passes through the deck.

The false deck should be designed to have adequate strength to support:

- anyone required to stand on the deck
- materials that need to be on the deck
- any materials or workers that should happen to fall.

The deck must be able to withstand:

- a point load of 2 kN distributed over an area of 100 x 100 mm (2 kN is approximately equivalent to a mass of 200 kg)
- a uniformly distributed load of 2 kPa, which is equivalent to a mass of 200 kg per m<sup>2</sup>.

When considering the design of the deck for erecting, altering or dismantling formwork, the weight of the false deck and any additional live loads must be applied to the analysis of the formwork support structure.

The height between the false deck and the pouring deck should allow comfortable access for a person during stripping.

#### 4.1.3 Erecting frames

Anyone involved in erecting formwork frames must be trained to do this safely. A person supervising the erection of formwork frame systems must be a competent person (as defined in Appendix 1).

The OHSW Regulations provide the requirements for training and responsibilities of workers performing a class of high risk work.

In cases where scaffold equipment is used as a formwork support structure and it is possible for a person or object to fall 4 m or more from the scaffold, the OHSW Regulations require a person to hold:

- a Basic Scaffolding licence (SB) to erect proprietary frames or
- an Intermediate Scaffolding licence (SI) to erect tube and fitting scaffold.

Trainees are permitted to perform scaffold work, provided they are under the direct supervision of a competent person who holds the scaffolding licence necessary for the task.

Formwork frames should be erected in a progressive manner to ensure both the installer's safety and the stability of the overall structure. Bracing is to be attached to the frames as soon as practicable. The risk of a fall from edges of formwork frames during their erection is high. In this situation, it is necessary to install edge protection on the frames as they are erected.

Conventional formwork frames include diagonally hinged braces that cross in the middle. While these braces are not considered to be suitable edge protection for a completed formwork deck, based on a risk assessment, they may provide reasonable fall protection during frame erection. Such fall protection exists only when braces are installed immediately, and in a progressive manner.

As the height of formwork frames increases, there is a greater need to provide lateral stability to the frame structure. All framing must be carried out so that it complies with on-site design documentation and any manufacturer's requirements.

#### 4.1.4 Installing bearers

When positioning bearers, installers must be located no more than 2 m from the floor or the fall arresting platform located immediately below them. For example, bearers can be lifted onto the top of the formwork frame by a person standing on a work platform erected within the frame and no more than 2 m from the floor or false deck located immediately below (see Figure 5 below).

Bearers must be positioned such that they will not fall from the frames. The common methods of ensuring this are to place the bearers in U-heads on top of the frames and also by ensuring cantilevers are minimised. Where only single bearers are placed in the U-head, the bearer must be placed and fixed centrally in the U-head unless a formwork designer or engineer states otherwise.

#### 4.1.5 Installing joists

Where a false deck is provided at 2 m or less below formwork level, joists may be spread on the bearers with the worker standing on the false deck. If the height of the formwork deck being constructed is more than 2 m above a continuous deck or surface, joists must be spread from a work platform, at least two planks wide, and located within 2 m of the surface underneath the deck being constructed (refer to Figure 5).

One example of a work system that may be used to do this is as follows:

*The joists are lifted by the workers and spread on top of the bearers into their approximate final positions whilst standing on a lower work platform. The platform below the deck must be positioned at a comfortable height for handling joists (without introducing manual task risks) and not greater than 2 m from the false deck.*

#### 4.1.6 Fall protection from the formwork deck

Continual modification of fall protection measures is necessary during formwork construction because the structure is constantly changing. One of the biggest challenges is to provide adequate fall protection on the leading edge of the formwork deck.

Where there is only one leading edge (i.e. the other edges are provided with scaffolding edge protection), the provision of fall protection is relatively straightforward. However, where there are multiple leading edges and/or the deck is not at one consistent level, the provision of fall protection can be difficult to implement. Designers of buildings are therefore encouraged to design floor slabs that are one consistent thickness (refer to section 2.1.1 'Buildability').

Leading edge and perimeter protection must be provided on edges where the potential fall distance is 2 m or more and a person is not prevented from being within 1.8 m of the edge. Control measures are required where a person could fall, from any height, onto an object such as frames, reinforcing steel or a rubbish skip.

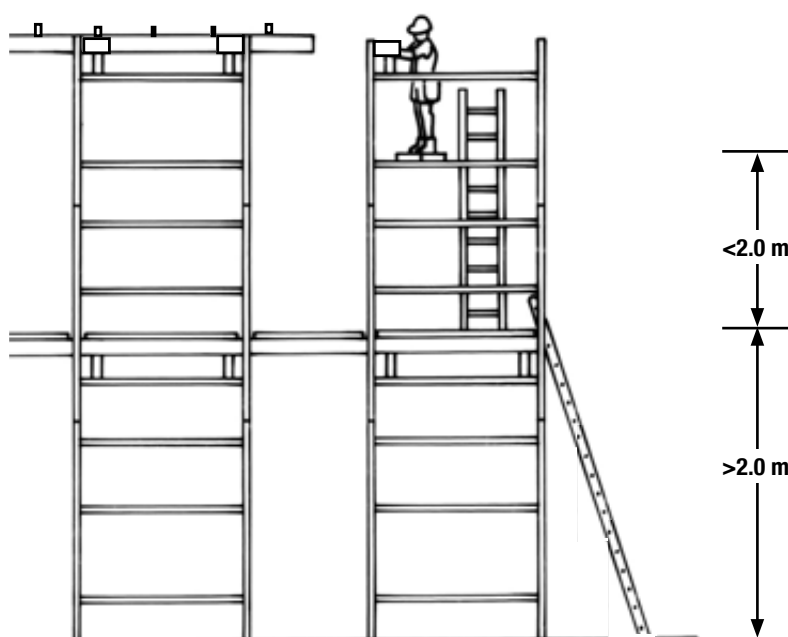

Figure 5 – Setting U-heads, bearers and joists from a two-plank platform

## Acceptable solid work zone barrier with 'No-Go' zone below



Figure 6a – General view

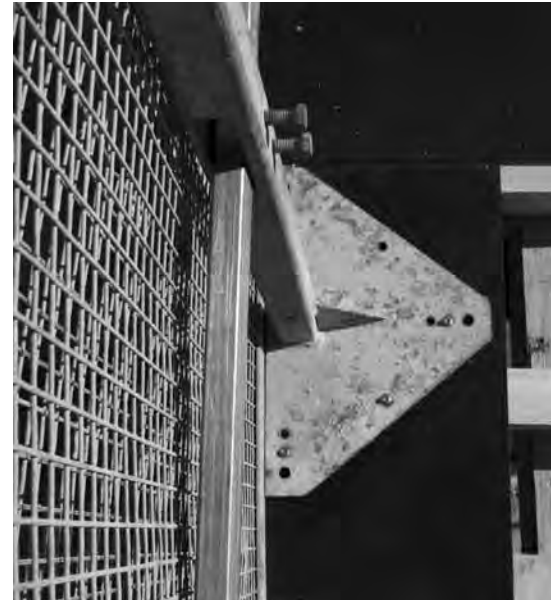

Figure 6b – Fixing detail

### 4.1.7 Edge protection on the formwork deck

#### 4.1.7.1 Formwork construction zone physical barriers

A physical barrier should be provided and maintained to separate the formwork work zone from other workers. This barrier must be rigid, capable of maintaining its integrity in an upright position and capable of supporting signage if required (see Figures 6a and 6b above).

**The use of flags and tape or unsupported barriers is not acceptable.**

Where the design of the formwork is complex and the profile of the deck is constantly changing, construction of leading edge protection may create more hazards than it would control. In such cases, it may be impractical to provide edge protection, as anyone installing the edge protection would be exposed to the risk of falls. In some situations perimeter edge protection must be installed. Examples include:

- where there is a change in deck height along the side of the deck being constructed, (i.e. a drop down for a beam) and no joists or form ply have yet been installed at this different height
- where a leading edge is to be left unattended and access onto the deck is required by anyone other than form workers (i.e. the formwork deck has not been barricaded off and marked with 'keep out' signs).

#### 4.1.7.2 Edge protection on completed decks

The most effective means of providing edge protection on a completed formwork deck is to install perimeter scaffolding.

Scaffolding is erected prior to the formwork and, therefore, prevents workers falling from the completed deck. The advantages of this system are that edge protection for installers of the final perimeter form ply sheets is already in place, there is no requirement to install edge protection on the perimeter, and no exposure to a risk of falling.

In some rare situations, it may be impractical to provide perimeter scaffolding. In such cases, edge protection must be installed and the work system used for this installation must include a control measure against the risk of a fall.

The use of harness systems is discouraged, because it does not provide an adequate level of protection from injury and is an impractical control for the risk of a fall from height in formwork erection (refer to section 1.1 of this guide).

In some situations, edge protection can be substituted with an alternative measure, provided this measure prevents a person falling from the edge. One alternative is the provision of a barricade, 1.8 m from the edge with clearly visible 'keep out' signs.

Further guidance on stanchions, guard rails (hand rails) and mid rails for minimum strength and rigidity is specified in *AS 1657 Fixed platforms, walkways, stairways and ladders – Design, construction and installation*.

Where scaffolding is over 4 m in height, only licensed and authorised scaffolders may erect, dismantle or alter the scaffolding. Any scaffolding components that are temporarily removed must be replaced at the earliest opportunity. Any gaps between a completed floor and scaffolding, that may exist after the formwork support system is removed, must be covered where there is a risk of a person or materials falling through.

### 4.1.8 Laying a formwork deck

#### 4.1.8.1 Getting started – safe access

After the supporting frames, bearers and joists are in position, the first essential consideration in laying a formwork deck is that all building work conducted at height requires some type of perimeter protection. The second essential consideration is that, for fall prevention, workers must stay away from a leading edge. How these essential elements are achieved is determined by the builder.

The first step in laying out a formwork deck is to provide safe access and a heavy duty bay to load and store materials, particularly a pack of form ply, at the form height. Successful solutions will be partially guided by the site itself, the size of the job or the contractor's preferred system, and may be an engineered solution, a scaffold solution or a formwork support system solution. Each has advantages and disadvantages.

### Engineered solutions

Generally, engineered solutions are economical to assemble, disassemble, use and maintain, and may be designed for a higher load-carrying capacity (with sufficient support frame capacity). They are more suitable for larger projects with more site room.

Engineered deck units are positioned and lifted by mechanical aids, such as multi-purpose tool carrier, forklift or crane, thus reducing the risk of injury from manual tasks. Drop-in hand railing systems are easily installed at ground level, reducing the risk of falls during erection.

However, engineered solutions generally have a higher capital cost to develop, manufacture or purchase. Engineered solutions are less flexible because there must be a clear access way of 450 mm. This limits available space for storage of materials on the deck (see Figure 7 below).

### Scaffold solutions

Scaffold solutions may be more flexible in their arrangement and would normally require a lower initial capital investment than engineered solutions. They are generally more suitable for smaller jobs and restricted sites. Scaffold system loading bays are manually erected, with the platform area and handrails being installed at height, increasing the risk of falls during erection.

The load carrying capacity of scaffold-based systems is generally lower than engineered solutions, being held within the allowable limits for *AS/NZS 1576.1:2010 Scaffolding Part 1: General Requirements*. However, scaffolding may be specifically designed for higher loads. Work platforms designed for higher loads must prominently display a sign indicating the SLL.

Scaffold-based systems are generally more adaptable in allowing for increased size of stored items, not necessarily being limited to the size requirements of 2400 x 1800 mm form ply sheets, whilst maintaining the necessary 600 mm minimum access width.

### Formwork support system solutions

Packs of form ply sheets may be placed directly on the joists of a formwork support system under certain circumstances. A section of the formwork support system may be a nominated loading area providing:

- the nominated loading area is certified by the engineer or formwork designer
- the maximum SLL of the area is marked on the formwork drawings, together with additional propping requirements



Figure 7 – Engineered loading bay.

Note: Drop-in handrails in place, lifting eyes, forklift slots, and built-in bearers

- any necessary additional props are installed and inspected prior to loading
- a perimeter scaffold is in place for fall protection
- the loading area is safely accessible from a perimeter scaffold or other safe access structure
- all joists and bearers forming part of the loading area are adequately secured in position to prevent a fall, as described in section 4.1.8.3 of this guide
- laying the form ply deck proceeds as described in section 4.1.8.3 of this guide
- a starting point for laying the deck is close to the form ply stack so as to minimise worker exposure to the risks of injury from manually handling the form ply sheets.

#### 4.1.8.2 Typical work system for a leading edge

The following work system may be used to construct the formwork deck for typical multi-level construction. The work system is specifically intended for situations where the vertical distance below the deck being constructed is greater than 2 m, but with the use of false decks may be used irrespective of the distance to the floor below.

1. Place bearers on the U-heads of the formwork frames from the working platform provided immediately below. Secure bearers to prevent movement, i.e. by nailing to, or wedging in, the U-heads before joists are placed on top. No eccentric (un-centred) loads should be applied to the U-heads unless specifically allowed by the formwork designer.
2. Place joists on the bearers in a progressive manner from the work platform located directly below the area to be worked on, and spaced at 450 mm centres (maximum) or so that the gap between joists does not exceed 400 mm. Secure the joists against any movement should a worker fall onto them.
3. Secure any cantilevered bearers and joists to prevent uplift or dislodgement prior to anyone working on them.
4. Lay out form ply, or other deck material, progressively as described in section 4.1.8.3. Wherever possible, the direction of the leading edge should be perpendicular to the joists, i.e. parallel to the bearers (refer Figure 8).
  - Form ply should be placed on the joists with the installer located behind the sheet as it is positioned whilst standing on the previously laid sheet or work platform provided. If this is done consistently, should a person trip or stumble they would fall onto the sheet and not from the leading edge.
  - Planning should take into account the optimum position for the loading bay, or direction of form ply placement so that laying out of the sheets starts at the loading bay where the form ply is initially stacked, reducing the need for manual handling and carrying sheets.

5. Cover or protect all penetrations left behind the leading edge. Covers must be securely fixed and clearly signed to indicate they are protecting a penetration (see section 4.1.10).
6. Nail or otherwise secure form ply to the joists as soon as practicable.
  - If timbers have not been fixed, edge protection complying with OHSW Regulations 2010 (Division 13 – Prevention of Falls), must be erected leading away from the sides of the leading edge.
  - Only personnel involved in the construction of the formwork may be located in the formwork construction zone. Anyone not involved in this process should be excluded.
  - The leading edge must be free of oil, sawdust and obstructions to reduce the likelihood of slips and trips.

#### 4.1.8.3 Laying a form ply deck

A formwork deck must be laid in a progressive way that includes a method of preventing falls below the deck. This control measure is particularly important in situations where a false deck has not been provided within 2 m below the level of the deck to be laid, and the potential fall distance is therefore greater than 2 m.

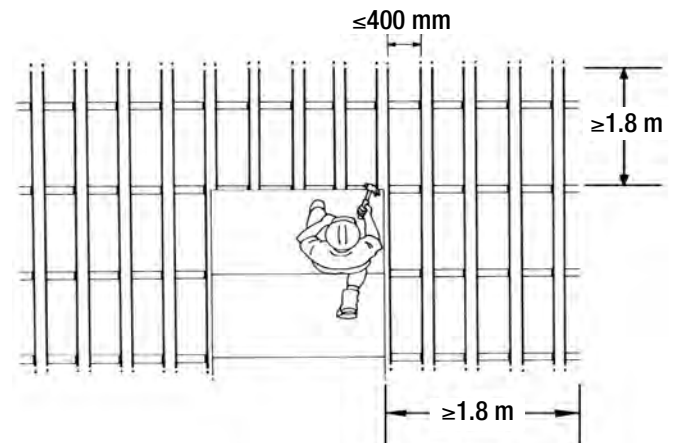

Figure 8 – Maximum spacing of timbers around worker where false deck is over 2 m below

Where a false deck has not been provided within 2 m, form ply may only be spread on the joists where:

- a minimum of four joists at 450 mm centres (400 mm gaps, totalling 1.8 m) are located on bearers next to the person, and the joists extend for at least 1.8 m all round (see Figure 8). Therefore, in the event of a fall, the person will fall onto the joists and be prevented from falling further
- laying the form ply sheets commences from the perimeter scaffolding or other edge protection that has been provided at the perimeter of the formwork, e.g. at the loading bay where the form ply is stacked
- the form ply is laid in front of the body so that if there is a stumble, the fall is likely to be on top of the sheets being laid



- joists are fixed to prevent sideways movement. In some situations, there may be a possibility of a person falling through the joists if the joists spread as the person's body makes contact with them during a fall. This is more likely to be a potential hazard when the person's fall is in the same direction as the lay of the joists. Fixing joists to prevent sideways movement will minimise this possibility.

#### 4.1.8.4 Laying a metal deck

A metal deck should be laid in a progressive way. Where a false deck has not been provided within 2 m below the level of the deck to be laid, metal decks may only be laid where the use of fall prevention systems have been provided. Work systems following the hierarchy of controls must be used. Examples include elevating work platforms, scaffolding, personal fall protection systems and anti-glare measures (refer to Figure 9).

#### 4.1.9 Cantilever requirements

*AS/NZS 4576: 1995 Guidelines for Scaffolding* requires that the design of cantilevered scaffolds and the adequacies of their supporting structures must be verified for compliance with the relevant requirements of *AS/NZS 1576.1 Scaffolding Part 1: General Requirements* by a competent person, such as an engineer with experience in structural design.

Cantilevered bearers, joists and ply sheets can be hazardous when left unsecured. The weight of a person standing on the cantilever may cause tilting, resulting in the person or material falling.

Formwork system designers should minimise the use of cantilevers where possible. However, in some situations where cantilevered

sections are unavoidable, the formwork designer or engineer must consider the potential for people and stored materials to cause cantilevers to pivot. Formwork designs must indicate where cantilevers are to be positively secured so that the weight of a person or material does not cause the section to pivot.

#### 4.1.10 Penetrations

Any penetration where there is a risk that a person or an object could fall through must be covered or securely guarded. Open penetrations, such as stairwell voids or penetrations to allow for services, create hazards for anyone on a formwork deck. A person may fall through larger penetrations, sustain injury by stepping into a smaller penetration, or an object may fall through the opening onto workers below. All penetrations must include cast-in metal mesh as a backup system.

The mesh should have a small aperture (e.g. 50 x 50 mm mesh size or smaller), and be made of material capable of withstanding the potential imposed load. Mesh provided over large penetrations may require engineering certification to ensure it can withstand potential loads including people, equipment and materials.

Where holes are cut in the mesh for services to pass through, the hole should be cut to the profile of the service so that mesh remains covering the penetration.

Ungraded plywood covers are not adequate because:

- the cover may be indistinguishable from other pieces of ply
- it may be difficult to determine if the plywood is properly secured
- secured plywood covers can be unsecured to gain access and subsequently may not be re-secured.



Figure 9 – Safe Work System for laying metal deck  
(Note: Fall prevention systems)

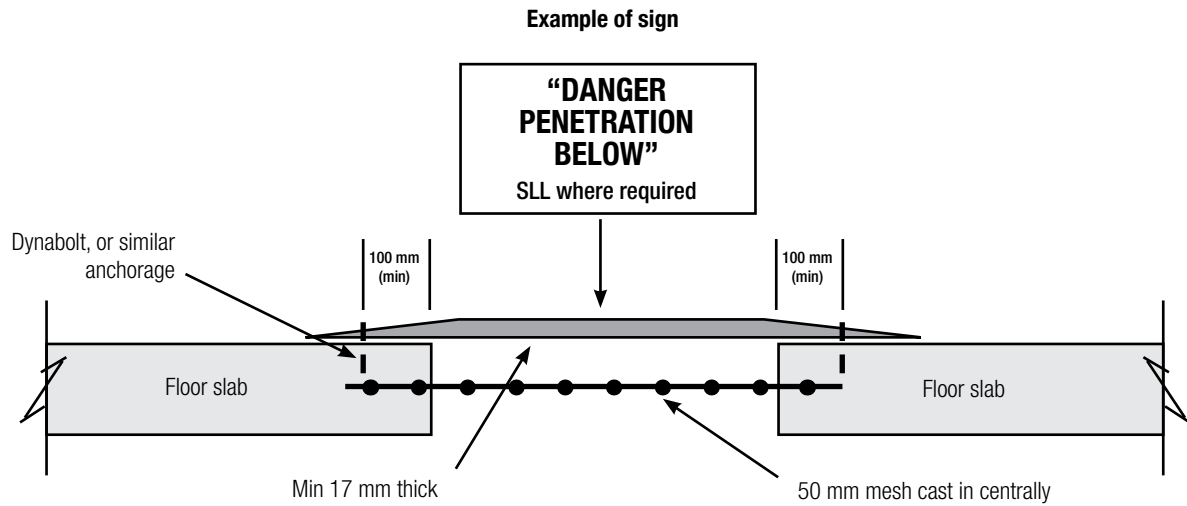

**Figure 10 – Example of acceptable penetration protection**

Plywood covers must be:

- structurally graded and sound
- a minimum of 17 mm thick
- painted a bright colour
- non-slip
- marked with the words **'DANGER PENETRATION BELOW'**.

The cover should be firmly secured to the concrete and designed for potential loads that may be applied. Refer to Figure 10 for an acceptable penetration protection design. Before stripping formwork, ensure the penetration that will be exposed is securely covered and protected.

Penetrations are also hazardous before the deck is laid. Joists placed up to the edge of the penetration must be secured so that the timbers cannot spread if a person falls on them.

#### **4.1.11 Working zones for form workers and others**

The formwork construction zone must be sufficiently large to ensure that formwork areas are clearly separated from other work areas. A 'formwork construction only' zone must be maintained behind the leading edge. This zone must be clearly demarcated by signage and a mesh barrier. Figure 11 illustrates the 'other work' zone, the formwork zone and the area retained as edge protection (four joists spaced 1800 mm beyond the laid deck).

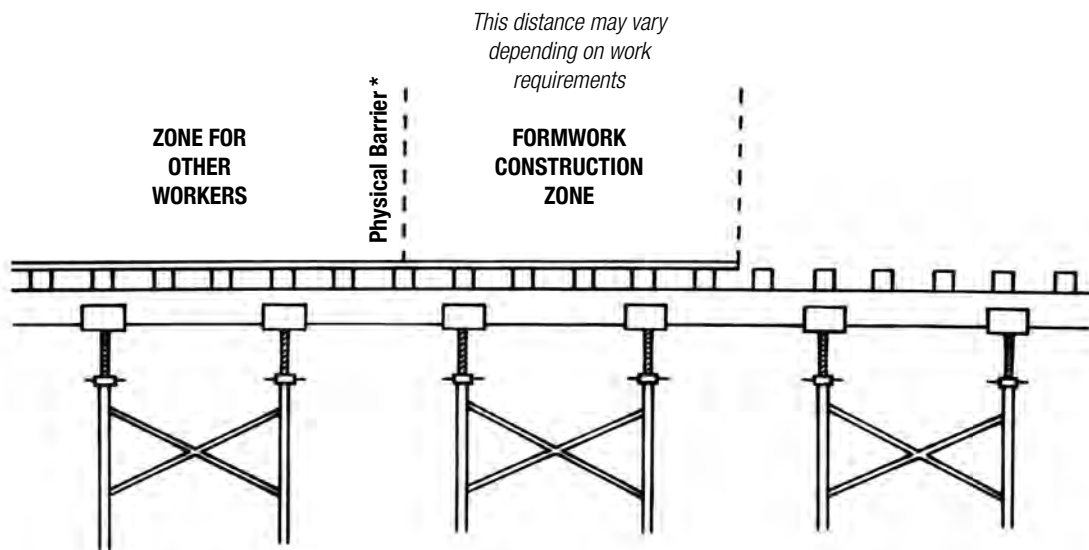

*\*Refer to 4.1.7.1 Formwork construction zone physical barriers*

**Figure 11 – End view of deck showing working zones**

#### 4.1.12 Changing floor levels

Formwork decks may not be flat across the entire floor, due to deep beams or 'drop downs' (sometimes called 'capitals') around columns. Such variable, uneven floors introduce trip and fall hazards during formwork erection. It is preferable that these hazards are eliminated at the design stage (see section 2.1.1 'Buildability'). Fall and trip hazards such as these are most effectively managed by ensuring that lower level formwork supports and decks are progressively constructed before work commences on the higher-level areas of the deck.

### 4.2 FORMWORK ERECTION – MODULAR FORMWORK SYSTEMS

#### 4.2.1 Basic modular systems

The basic principles discussed in section 4.1 of this guide on traditional systems apply to the erection of modular formwork systems. Although the erection technique and member dimensions may vary greatly between traditional systems and modular systems, the principles of maximum potential fall distance and gap width at the working level are applicable:

- the width of any gap on a working level is not to exceed 400 mm unless a false deck has been provided within 2 m of the working level
- working platforms used for modular systems must also have a minimum width of 450 mm.

Both modular and traditional formwork systems must be designed to comply with the loadings and general principles of *AS 3610: Formwork for Concrete*.

Traditional formwork systems are sometimes used adjacent and connected to modular systems, particularly for unusually shaped areas. Where this is the case, the formwork drawings should show any essential connection or design details and be certified by an engineer or formwork designer. However, components from one proprietary type of formwork system should not be used as integral parts of other modular formwork systems unless the designer of the modular system states in writing that this is permitted.

Modular formwork systems are often manufactured from aluminium instead of steel and are therefore lighter in weight. Being lightweight, they require less physical effort to erect than traditional systems, and also the need for repetitive hammering may be eliminated, reducing workers' exposure to the risk of injury from manual tasks.

Because modular systems are lighter in weight they may be more susceptible to overturning during erection when exposed to eccentric loading factors such as wind loading etc. This is generally an issue only prior to placement of the decking on the modular support system. To effectively control any instability, modular formwork systems must be progressively braced during erection in accordance with the manufacturer's instructions.

#### 4.2.2 Training

Workers involved in the erection of modular formwork systems must be trained in the safe erection and dismantling of the system and the inspection criteria for components, particularly for defects that would preclude their use.

The modular system supplier or designer should provide written instructions for the erection and dismantling of the system. Instructions should include safety instructions equivalent to those detailed in this guide.

Training by the modular formwork system supplier is encouraged. For training requirements refer to Appendix 2.

#### 4.3 STRIPPING FORMWORK

Stripping formwork can be one of the most hazardous phases of concrete construction.

While falling objects are the primary hazard, there may also be fall hazards as a result of floor, scaffold or formwork collapse, as well as manual task hazards from a person working in awkward postures, repetitive handling of materials, or limited task variety.

Workers must be informed of the risks and be adequately trained, so that stripping operations are carried out in an orderly, progressive manner, as occurs with formwork erection.

##### 4.3.1 General formwork stripping

To reduce the risk of injury when stripping formwork/false work:

- install fully-decked work platforms at a height no greater than 2 m from ground level or the catch deck
- erect a catch deck no more than 2 m below the work area
- suitably barricade and signpost the stripping area (with barrier mesh as a minimum).

##### 4.3.2 Safe work method statements

Only an experienced and competent person should prepare safe work method statements for the stripping operation. Properly prepared statements are very useful as a training tool for those who will be involved in this high risk activity. The safe work method statement should detail factors such as:

- the hazards related to the stripping process and any equipment and strategies to eliminate or minimise the risks
- the number of people in the stripping crew
- the sequence of stripping activities e.g. detailing how the frames and/or other supports are to be removed and how far U-heads may be lowered
- whether the support system may be completely removed in a zone prior to removal of the formwork deck, or whether the supports are to be lowered slightly but still remain under the form ply while it is being removed

- when back-propping is required or only part of the support system is to be removed, how the structural members are to remain in place and/or the type and layout of members that will replace the formwork system
- any other special requirements involved in the stripping and or building processes e.g. checking of back-propping after post-tensioning.

#### 4.3.3 Certification prior to stripping

Prior to commencement of the stripping operation, an engineer must provide written certification that formwork can be removed. This certification should be based on an engineer's specifications for the building, the strength of the concrete mix and the time period that has elapsed since the pour.

An engineer may also be required to have input into the stripping safe work method statement to ensure the concrete element does not fail, and must provide sufficient detail on the structural engineering drawings as required by section 17 'Formwork' of *AS 3600 – Concrete Structures*.

Documentation from the concrete supplier verifying the concrete specification should be available on request. A concrete sampling and testing procedure should be in place to verify that concrete meets its design specification for stripping purposes. Guidance on sampling and testing systems for concrete is provided in *AS 1379:2007 Specification and Supply of Concrete*.

#### 4.3.4 Exclusion zone

Only those involved in the stripping operation are permitted in an area to be stripped. Stripping areas must be cordoned off and signs displayed to keep non-essential personnel out of the area e.g. '**DANGER – FORMWORK STRIPPING IN PROGRESS – AUTHORISED PERSONS ONLY**'.

It is preferable to restrict access to the whole floor where soffit stripping is taking place. This would not only be safer, but also reduces the quantity of signage and barricades required.

Where other trades or sub-contractors are required to work on the same floor during the stripping of walls, columns or small sections of soffit, the principal contractor or employer must ensure that controls are applied to prevent non-essential personnel from entering the stripping area.

#### 4.3.5 Drop stripping

Drop stripping is an unsafe method of work and cannot be supported by this guidance document. In cases where drop stripping is being considered, the formwork and support design, and the concrete element design, should be reviewed by the designer and modified to eliminate drop stripping.

#### 4.3.6 Bond reduction

Stripping of formwork may be aided by reducing the bond between the form material and the concrete. Bond strength is dependent on the material characteristics, the smoothness of the form material and age of the concrete. The use of a liquid bond breaker on wall and column forms is one way of reducing the strength of the bond. However, the use of bond breaker on floor forms is not encouraged because of the slip hazard that may result.

### 4.4 CRANE AND OTHER LOAD HANDLING SYSTEMS

#### 4.4.1 Loading materials during formwork construction

Formwork structures are not necessarily safe to accept any excess loading until they are fully-secured. That is, until after the deck is in place with tie-ins and propping complete, and any proposed loading area certified.

In practice, some loading occurs before a deck is completed e.g. unloading pallets of ply and joists on a partially constructed formwork structure, to continue the deck. This is an unacceptable and dangerous practice which could lead to a full structural collapse of the deck, possibly resulting in serious or fatal injury. To ensure the integral safety of the deck, materials may only be stored where and when the deck is certified as able to bear the load.

Form workers and crane crews must be made aware of the specific locations and loads for certified loading areas, and that stacked materials may create point loadings, which a formwork structure may not be designed to bear at that point.

To minimise the risk of collapse and other hazards:

- loads must not be placed on the formwork deck if the formwork documentation prohibits loading
- formwork drawings must clearly identify the locations and SLL for maximum (pre-pour) point loadings for the deck. These locations must be specified by a formwork designer or engineer
- crane crews may not lift materials onto the deck until there is a designated lifting zone
- crane crews must be notified when an area of deck is ready to take a load, and specified loads may only be placed in the area/s designated and placed so that they cannot fall
- delivery of materials to the site should be planned so that loads are not lifted onto unsecured decks
- prior to workers leaving the site, materials and equipment should be secured to prevent them being moved by wind.

#### 4.4.2 Slinging loads

Slinging and un-slinging loads at height is always a high risk activity. Safe work methods and fall prevention systems are essential for this activity (refer to section 4.1.8.1)

A dogman, or other person engaged in slinging loads, must be provided with adequate fall protection and a safe means of access

when working at 2 m or more above the deck.

The use of fall arrest systems for workers slinging formwork loads is usually impractical and is not recommended. However, it may be reasonably practicable to fit platforms and edge protection as fall protection.

#### 4.4.3 Lifting gear

Guidance on the use and inspection of chains, wire ropes and synthetic slings is provided in the following publications:

- *AS 2759: 2004 Steel wire rope – Use, operation and maintenance*
- *AS 3775.2: 2004 Chain slings – Grade T Part 2: Care and use*
- *AS 1353.2: 1997 Flat synthetic webbing slings Part 2: Care and use.*

Basic items that need to be checked include:

- lifting gear is tagged and all relevant information listed (e.g. relevant information for a chain sling is grade of chain, safe working load, manufacturer, chain size and Australian Standard marking)
- lifting hooks have operable safety latches
- lifting eyes and inserts are compatible
- lifting slings are serviceable and not damaged (i.e. have no excessive wear, damaged strands, cracks, deformation and/or severe corrosion)
- synthetic fibre slings are maintained in good condition, are rated for the load being lifted, have a suitable slinging configuration and are protected from sharp edges.

It is most important that all lifting gear including slings, hooks, wire ropes, pendants and material boxes are periodically inspected for damage and wear. The period between inspections may depend on the severity of use with the exception of:

- chain slings, where inspections must not exceed 12 months
- synthetic fibre slings, where inspection for damage must be undertaken before each use and full inspection at least every three months. Refer to section 9 of *AS 1353 .2: 1997 Flat synthetic webbing slings*, part 2: 'Care and use for inspection items' and section 11 for 'Discard Criteria'.

Documented maintenance records for the lifting gear should be available for inspection on-site.

#### 4.4.4 Lifting formwork materials

- Crane-lifted loads must be slung and secured so that the load (or any part of it) cannot fall.
- Weights of wall, lift or column forms should be provided on-site with formwork documentation and made available for inspection by all interested parties.
- SLLs must be clearly marked on bins.

- Lifting boxes intended for lifting people must be design registered with SafeWork SA and suitably constructed for other material being lifted.
- Four chains (one in each corner) must be fitted to lift boxes to maintain stability.
- Lifting boxes must be inspected, maintained, and inspection records kept.
- Specifically-designed lifting boxes should be used to lift smaller components (e.g. spigots, U-heads, base plates and couplers). Boxes must have enclosed sides or robust mesh (with openings less than the minimum size of materials being lifted).
- Loads contained within lifting boxes should be secured against movement.
- Materials must not be stacked higher than the side of the box unless they are adequately secured.
- Formwork support frames must either be tied together or secured with lifting slings wrapped around the load.
- Loads of joists or bearers should be strapped together before lifting.
- Tag lines must be used to control loads and forms, and must be fixed to the load, not the lifting gear.
- Form ply loads should be strapped together and lifted in a flat position.
- Ensure, where possible, that all loads are supported on dunnage and the load is uniformly distributed over the supporting surface.

Prior to lifting any items:

- remove any waste concrete etc. from forms or any other materials or equipment to be lifted to ensure the waste does not fall onto people below
- inspect all loads closely to ensure all loose materials and tools have been removed.

#### 4.4.5 Lifting lugs

Chain slings attached to lugs or holes cut into part of a load are often used to lift bins, wall, lift well or column forms (instead of wrapping the lifting slings around the load). Information verifying the structural adequacy of the lifting points must be available.

An engineer must verify:

- the structural adequacy of the lifting lug
- the means of attachment to the load (usually welded or bolted).

### 4.5 USE OF LADDERS

Ladders must be secured at the top or base, or when this is impractical, held firmly at the base by another person.

Where practicable, alternatives to ladders such as work platforms or stair access systems must be used. Fixed or permanent ladders must comply with *AS 1657 – Fixed platforms, walkways, stairways and ladders – Design, construction and installation*.

Where ladders are provided as access to a live deck:

- they must extend at least one metre above the accessed surface, be secured against movement and be set up on a firm, level surface
- they must be of industrial standard with a load rating of at least 120 kg
- single and extension ladders must be placed at an angle of between 70 degrees and 80 degrees to the horizontal ('4 up, 1 out' rule), except in some rare situations where this is impractical
- single ladders must not exceed 6.1 m in length and extension ladders must not exceed 7.5 m.

Other issues regarding the safe use of ladders include:

- metal or metal reinforced ladders must not be used in the vicinity of live electrical equipment. The Office of the Technical Regulator (OTR) provides information on compliance with safe working distances in the vicinity of live electrical wires
- never touch a ladder that is in contact with electrical power lines
- a person's feet must always be more than 1 m from the top of the ladder
- ladders are not to be used on scaffolding or elevated work platforms to gain extra height
- ladders must not be positioned above or adjacent to openings or edges where a potential fall could occur. A work platform with edge protection should be used instead
- ladders should not be used in access ways or where there is pedestrian, vehicular or mobile plant traffic unless a risk assessment has been undertaken and other precautions have been considered
- always maintain three points of contact when using ladders.

## 5. Special requirements for wall and column forms

### 5.1 BRACING FOR WIND LOADING

Wall and column forms must be designed to withstand all live and dead loads, including wind load prior to, during, and after the concrete pour. The bracing and forms must not be removed from the cast element until it is sufficiently mature to safely withstand potential impact loads and wind loads.

Prior to stripping, an engineer or other competent person must provide written certification that the formwork can be removed.

Bracing must be designed to suit its application and verified by the designer (refer to section 2.2.1). Bracing elements must be designed and installed to resist both positive and negative wind generated loads. Bracing anchors should preferably be cast-in type or 'through-bolts' that extend through both sides of the anchoring medium. Drill-in anchors of the following type may be used, provided they are installed in accordance with the manufacturer's instructions:

- undercut type anchor that does not rely on friction to function
- expansion anchors of the high-load slip, torque controlled type
- coil bolts. The correct operation of coil bolts is greatly dependent on whether they are installed in accordance with a manufacturer's specifications (e.g. drilling the correct sized hole and applying the correct torque in concrete of adequate strength).

Drill-in type anchors may have a specific installation torque set requirement to function correctly. Torque measurements should be made using an accurately adjustable torque wrench. An alternative method that may be used to verify the torque could be a calibrated 'rattle gun'. Records verifying the setting torque for all drill-in type anchors should be available on-site. Manufacturers normally specify the minimum distance from a concrete edge that an expansion anchor may be installed.

### 5.2 ACCESS PLATFORMS

Mobile scaffolding, purpose built work platforms or elevating work platforms may be suitable in providing the essential safe access to elevated work areas for dogmen, steel fixers and concreters. Edge protection must be provided on any access platform.

Platforms must be designed to provide sufficient access and working space for the number of personnel required for specific tasks, and must be positioned at a height and distance from the form so as to minimise reaching and stretching movements and limit a person's necessary exertion.

Concrete pouring systems must provide adequate safe working space, with edge protection provided, for all workers.

Castors on mobile work platforms must be locked at all times except when they are being moved.

All platforms must be designed for stability and resistance to any side loading that may be applied during a concrete pour. Lightweight aluminium scaffolding may not have adequate stability when subjected to side loading and may require additional bracing.

### 5.3 LIFTING METHODS

Wall and column forms may only be lifted with a positive lifting system, such as lifting lugs or by wrapping lifting slings around the form such that the form cannot slip out of the slings. Purpose designed lifting lugs must be used wherever practicable (refer to section 4.4.5).

An engineer must provide documented designs for wall and column form lifting points, and the design documentation should be available on-site. Where lifting lugs are attached to the form, an engineer must specify the fixing or weld design, and the manufacturer must ensure and certify that the attachment or weld complies with the design requirements.

Forming lifting points by cutting holes with oxy-acetylene torches is unacceptable and must not be used as:

- the load carrying capacity cannot be guaranteed
- it may be difficult to attach lifting gear
- positioning of the hole may be inaccurate
- the form may be damaged.

## 6. Special requirements for slip forms and jump forms

This section applies to slip forms, jump forms and crane-lifted forms that incorporate working platforms and enclosed cells in which people are required to work.

Slip forms and jump forms are terms given to self-climbing formwork systems specifically intended to construct concrete service cores, walls and columns in high rise buildings and other concrete structures such as silos and chimneys. In slip forms, the climbing is usually carried out continuously during the concrete pour which may be completed to full height in one pouring operation. With jump forms, the climbing is done in steps, lifting the complete form unit to the next level following each concrete pour. The term 'climbing form' is also used to describe either a slip form or jump form. Climbing operations are usually powered by hydraulic rams or electric motors connected to climbing feet or screw shafts.

Slip forms and jump forms usually consist of a number of decks and may also be fitted with trailing screens that are suspended from the form. As with perimeter screens, trailing screens may:

- provide edge protection
- prevent materials from falling
- provide support for work platforms, or a combination of these uses.

No two slip forms or jump forms will necessarily be identical, as their design will be based on the size and configuration of the structure or building under construction.

The work systems and layout of some crane-lifted forms may also be similar to those associated with slip forms and jump forms. This may be the case for crane-lifted forms provided for the inside of lift shafts. While most of the information in this section applies to slip forms and jump forms, some of the principles may also apply to crane-lifted forms.

When designing and operating these types of form systems, the following issues must be addressed:

- provide safe access to all areas and work platforms
- control risks associated with working at height
- develop safe work method statements and using them to train workers in the safe operation of slip and climb form systems
- provide sufficient working space and head room

- specify and provide safe work method statements for manual handling of shutters and other components, e.g. the use of cranes to lift shutters and provision of safe access for workers attaching slings to shutters
- ensure adequate ventilation and lighting in all work areas
- provide adequate amenities for workers given that slip form operations often continue for extended shifts
- always use Hot Work Permits for slip form and jump form systems
- ensure sufficient fire extinguishers are provided
- ensure emergency procedures, including for the retrieval of an injured or incapacitated person from any work area located within the structure are developed, implemented and trialled.

It is acknowledged that it may not be practicable to provide an access system and working environment on a jump form or slip form that is of the same standard as elsewhere. However, anyone in control of a project, task or workers must comply with their obligations under the OHSW Act.

### 6.1 ACCESS AND EGRESS

Access to slip form and jump form systems may be provided in a variety of ways including one or more of the following:

- personnel and material hoists on the building
- permanent stair systems in the building
- a trailing stair system suspended from the slip form or jump form
- a trailing ladder system.

A trailing stair system is preferable to a ladder system as it is easier to ascend and descend, and emergency evacuation is generally safer and easier on a stair system. The access area between the trailing access system and the building must be clear of trip hazards and there should be no gaps exceeding 50 mm wide between platforms.

The formwork designer must ensure that a trailing access system is designed for additional loads that could be applied in an emergency evacuation situation. The design must ensure that not only the strength of the form system itself is adequate, but also the formwork structure safely supports any applied loads from the access system.

A trailing stair access system should be designed for a load of at least 2.5 kPa unless the designer specifies otherwise. Where the designer specifies a lesser live load than 2.5 kPa, the following applies:

- a sign stating the maximum load limit must be fixed to the stairs in a visible position
- written procedures must be implemented to ensure the total load limit is not exceeded.

Ladders must be secured in place and be placed at an angle between 70 and 80 degrees to the horizontal, where this is practical.

Access openings for ladders on working decks should be provided with trapdoors that are closed when not in use, easily opened from above, and do not create a trip hazard on the deck.

Access ways should be kept free of materials and rubbish to prevent objects falling to the level/s below.

## 6.2 WORK PLATFORMS

Division 13 – Prevention of falls of the OHSW Regulations specifies requirements for work platforms. These requirements also apply to slip forms and jump forms. However, the following points highlight specific issues that may apply:

- When placing steel or pouring concrete into a form, controls must be implemented that prevent a person falling into or from the form. The risk of this is higher when the form is greater than 225 mm wide prior to placement of reinforcing steel. Workers must also be protected from the risk of being impaled on projecting reinforcing bars or other objects. Suitable controls may include edge protection on the internal side of the working platform, or reinforcement mesh temporarily placed on top of the form, enabling the steel to be fed through the mesh (see Figure 12).



**Figure 12 – Mesh used as fall protection on wall pour**

- The design and construction of platforms must include positive fixed security so that jamming or movement cannot occur under eccentric loads e.g. where work platforms have a trailing screen on one side and are supported by a building parapet on the other, uplift may occur from wind loading or where a platform is not level and is unsecured. If this occurs, the platform may jam or otherwise move under the unbalanced load, causing a person to fall.
- Where individual cells of a form are climbed at different times, edge protection must be provided separately on each cell.
- Safe work method statements, developed for all higher risk aspects of slip form or jump form systems and access systems, will assist in ensuring safe systems are implemented and provide a sound training aid for workers engaged in this activity.

## 6.3 TRAILING SCREENS AND PLATFORMS

Trailing screens can provide edge protection and a means of preventing falling objects. They can also be designed to support lower, suspended working platforms for repairing or patching concrete, and to provide access for anyone climbing the form. The formwork designer will need to specifically address and document all issues for which the trailing screen system is designed. The design must address the following:

- There must be a suitable design loading for any platforms on the trailing system. As a guide, platforms must be designed to support a minimum load of 2.5 kPa. A designer may reduce this if the number of people is strictly limited and controls are implemented on-site to ensure the specified load is not exceeded. If the design load is less than 2.5 kPa, this must be stated in documentation kept on-site and signs must be fixed to the platforms stating the maximum load permitted in kilograms. Site personnel must be made aware of and comply with the maximum loading that applies to the trailing platform.
- Strategies must be implemented to adequately control the risk from falling materials (see section 5 for further guidance).
- All platforms must be secured to prevent uplift or any other unplanned movement.
- A risk assessment of a form system must include the need for, and use of, ladders and edge protection. The system must meet the requirements of the OHSW Regulations.
- A person must not ride on trailing platforms while the platforms are being crane-lifted. If access or work is required whilst a crane supports the trailing platform, another work system must be devised. This could involve another crane with a registered workbox, or a separate access scaffold system.
- Any work system chosen must comply with the OHSW Regulations and include safe work method statements based on risk assessment, with risk control strategies based on application of the hierarchy of control.

## 6.4 CLIMBING THE FORM

Climbing is usually carried out using a series of climbing devices set up to lift at the same time and at the same rate. If the lifting system is not properly synchronised the form may become wedged on the structure, or structural members may be overloaded and become unstable.

There should be a systematic approach to ensure that the form remains within level tolerances during the climbing process. The system may be automated or may rely on operators stopping each individual device controlling the climbing process. Whichever process is used, the following must be observed:

- A safe work method statement must be developed to train personnel and manage the climbing process.



- Only those workers directly involved with the climbing process may be on the form during the climb.
- Any potential nip or shear points where a person could be injured during the climb must be identified and controlled.
- All obstructions and loose items on the form are to be removed prior to climbing. An inspection checklist and 'sign-off' procedure for this should be implemented. Items typically left on forms include Z-bars, ferrule bolts, insert anchors, covers and hand tools.
- It is important to ensure the different parts of the form remain level during the climbing process.
- Electrical cables, water and other piped services should be designed and installed so that they will not catch or rupture as the form is climbed.

Forms must be effectively supported at all times during climbing operations, particularly when removing a form from a vertical element. Serious incidents have occurred when it has been assumed that a form is supported from a crane, when it is only relying on 'through bolts' for support.

In one incident, when the bolts were removed, the form-to-concrete adhesive forces failed a short time later. The form fell while workers were still standing on a platform attached to it.

This hazard applies to both crane-lifted forms and jump forms, which must always have a positive means of support. Workers must never be in a position where they rely on formwork adhering to the concrete surface for support.

## 6.5 TRAINING

Slip form and jump form operations require specialised work systems and present unique hazards to workers, requiring specific training and specialised safe work method statements for personnel working on the forms.

Training and the development of safe work method statements, should include, but not be limited to:

- the maximum loadings that can be applied to the various areas on the form. This would include information about areas where materials can be stored
- restricted access areas and procedures for the installation and removal of edge protection
- slip or jumping procedures for those involved in these operations
- requirements for the application of Hot Work permits
- emergency evacuation procedures for those required to work on the form
- fire fighting procedures to be used in emergency situations prior to fire fighting personnel arriving at the scene
- any other special work procedures that specifically apply to working on the form, e.g. time limits (where these apply) for working in cells or safe undertaking of manual tasks

- communication and remote work systems – no person is to work alone and 'buddy' systems are to be encouraged.

Refer to Appendix 2 for other training in different areas.

## 6.6 HEALTH ISSUES AND AMENITIES

Safe access and adequate ventilation to all cells must be provided in climbing form systems. Extended periods in hot and cramped working conditions create a difficult working environment and these issues should be considered during planning and job design. It may be necessary to specify job rotations or maximum times spent in cells, depending on temperature, humidity, cell size and the particular activities being undertaken. Time limits and job rotation should be considered in consultation with workers when developing safe work method statements.

Due to the nature of the work and the work environment, the provision of additional drinking water supplies, toilets and amenities may also be required.

## 6.7 ENGINEERING ISSUES

The design of climbing form systems is more complex than formwork systems for floors and includes the consideration of wind loading and other stresses generated during climbing. Such formwork systems require greater technical and engineering input, and must be classified as non-basic, with an engineer as the designer.

The climbing form designer must be involved in both the design of the form and in developing safe work method statements, so that any ongoing design issues occurring during form erection over the life of the building project are addressed.

Some design problems associated with climbing form systems may not become apparent until the job is in progress and system design changes may be necessary. Designers and principal contractors must implement consultative arrangements that include regular inspections of the works during a climb, and consultation with those involved in the operation to identify any difficulties or safety issues.

Section 2 of this document discusses engineering issues associated with formwork in general. In addition to those issues, the designer must address the following factors for climbing systems:

- minimum concrete strength required prior to climbing
- allowance for all loads, including all live and dead loads that may be applied to the form system such as:
  - loads created by workers, impact loads from materials lifted onto the form and concrete-placing activities
  - the effects of additional and eccentric loading during climbing
- the maximum allowable skew during a climb, and any procedures to either minimise the possibility of this occurring, or rectify a situation if forms do become skewed

- any effect rescue procedures may have on the design or operation of the form. Rescue procedures may require access to all levels of the form and cells, either through the provision of gates or by removal of panels on the form.

Any specific risk control requirements must be documented in the safe work method statements.

## 6.8 EMERGENCY ISSUES

Fire extinguishers, hoses and other means of fire prevention and control must be provided on climbing forms in accordance with relevant legislation. Emergency procedures must be developed, documented and implemented and all personnel must receive training on the procedures. A list of those who have received training must be documented and kept (refer Figure 13).

The emergency procedures must include as a minimum:

- methods for alerting workers in the event of an emergency
- methods and timing for evacuating workers from each location or cell
- rescue procedures in the event of severe medical conditions
- who is responsible for ensuring evacuation takes place
- personnel in the emergency response team
- training requirements for anyone involved in rescuing others, where outside experts cannot be responsible for performing the rescue
- training in the use of fire extinguishers
- evacuation muster points both on and off the form.

In remote areas, a more thorough risk assessment must be carried out for emergency rescue.

Where a form can be accessed using cranes on-site, a design-registered first aid box for emergency rescue of an injured and incapacitated person/s must be readily available and accessible at all times while work is being undertaken.

Both designers and those in control of a site or task must consider the effect the formwork design may have during an emergency response, as well as their ongoing responsibility during construction.

Safely removing an immobilised or unconscious person during an emergency evacuation of a formwork cell needs to be considered and planned for. This may include creating emergency access holes and doorways through decks and screens. Procedures must identify how to access lift-voids and other areas, including cells within the core, which may have limited access.

Emergency services contacts must be clearly identified and be prominently displayed on-site. All parties on-site, including the principal contractor, sub-contractors and workers, must agree on the nominated emergency service contacts.



Figure 13 – First aid, fire control and emergency retrieval equipment on-site

## 7. Falling objects

### 7.1 HAZARD CONTROLS

Hazards from falling objects are significant and can be present whenever workers and others are erecting, altering or stripping formwork, when slipping and jumping formwork operations are occurring, and also whenever loads are lifted over work areas.

Anyone in control of a worksite, work area or task has an obligation to control any risks from falling objects where workers or any other person could be injured by a falling object during formwork activities.

Even small objects, such as bolts or concrete aggregate, falling from height can cause serious injury. Control measures must aim to prevent objects from falling or, if this is not reasonably practicable, prevent injury if an object has fallen.

In particular, when erecting or dismantling formwork:

- close-off adjoining areas to non-essential personnel to prevent objects falling on or hitting people
- erect perimeter containment screens for each part of the building from where objects could fall
- ensure control measures are in place to prevent screen components from falling during erection, extension or reduction of perimeter containment screening.

### 7.2 PREVENT THE OBJECT FROM FALLING

Controls must be applied at the source to prevent objects from falling; that is, eliminate the risk. This is the most effective control to prevent injury or death caused by falling objects.

Good housekeeping practices are the most effective way of preventing small objects from falling. Ensure items are cleaned up and kept away from edges, voids and penetrations.

The recommended control measure to prevent objects from falling outside the structure is the use of perimeter containment screens. The screens are effective as a control measure from falling objects for the protection of the public in adjoining areas as well as for safety and protection on-site.

### 7.3 PERIMETER CONTAINMENT SCREENS

Perimeter containment screens are protective structures fixed to the perimeter of a building, structure or working platform. Their essential purpose is to prevent objects and people from falling outside the work area, significantly reducing the risk of injury to workers and the public.

Screens should be used during the full construction process, especially during formwork erection or stripping. They are usually sheeted with:

- timber
- plywood
- metal or synthetic mesh.

Containment screens may be supported by the building or structure, or by specifically designed scaffolding. The screens can also act as perimeter fall protection on a top working platform. To fully comply with these requirements, the screens must extend at least 2 m above the working surface.

When formwork is being erected or dismantled immediately adjacent to screens, they must extend a minimum of 2 m above the working deck/stripping area to provide a higher level of protection for the public and for those workers outside the building area.

When selecting containment screens, consideration must be given to its:

- ability to support or contain imposed impact loads, including building materials, equipment and waste materials
- resistance to wind loads on the supporting structure
- required frequency of inspection
- chemical reactivity, including flammability
- ventilation requirements (refer to *AS 1668.2: 2002 The use of ventilation and airconditioning in buildings – Ventilation design for indoor air contaminant control* for guidance)
- light transmission requirements (refer to *AS 1680:1976 Code of practice for interior lighting and the visual environment* for guidance)
- degree of protection provided from rain or washing down operations
- pattern and frequency of fixing points
- gaps created by a fixing method.

Containment screens must remain in position to prevent any object falling for the full duration of formwork operations – from commencing formwork erection until soffit stripping is complete and all materials are removed from, or stacked on, the floor.

#### 7.3.1 Screen height at building step-ins

As stated above, perimeter containment screens must extend above the formwork erection area so that materials cannot fall to the ground, or onto other work or traffic areas.

Where the horizontal surface under construction steps in from the overall building perimeter, e.g. for a plant room on a building roof, the perimeter screens must be erected to a height that will prevent any materials falling to the ground from the top of the stepped-in structure.

One example of an acceptable method to prevent falling objects reaching the ground is illustrated in Figure 14. In this example, the outside edge of the stepped in structure is 'W' metres from the perimeter containment screen and the lift height is 'H' metres.

To prevent an object falling from the top of the stepped-in structure, or being ejected from the top level, and falling to the ground outside the building perimeter, the height of the screen should be such that the angle of an imaginary line from the top of the screen to the top

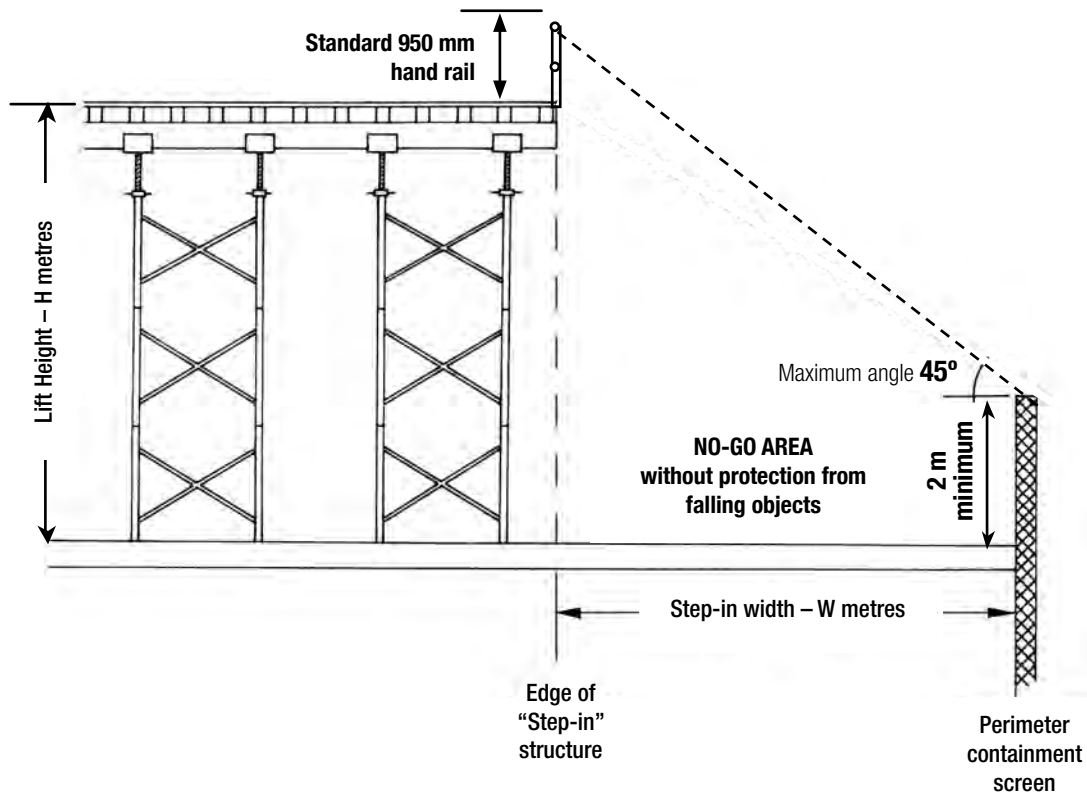

Figure 14 – Height of perimeter screen for protection from falling objects on the ground at building step-in

of the formwork platform rail is a maximum of 45 degrees to the horizontal, with a minimum acceptable screen height of 2 m.

**The calculation for the required screen height is:**

**Screen Height (metres) = (H + 0.95) metres – W metres  
(with a minimum acceptable height of 2 m)**

Non-essential personnel must not enter the ‘No-Go’ area next to the step-in unless positive controls are in place to prevent anyone being struck by falling objects e.g. catch platforms or further screening.

### 7.3.2 Perimeter screen gaps

To prevent material from falling below, gaps between perimeter screens and the formwork deck or floor must not exceed 25 mm. This can be achieved by:

- installing permanently fixed ply covers
- installing catch platforms – removable shields that are connected to screens, with procedures to ensure the adjacent area is cleaned up before the shields are removed.

Covers must be designed for potential loadings, such as loads applied by workers and the impact loadings of falling materials. They must also be marked with a SLL if they can be accessed as a platform.

Catch platforms deflect falling objects back into the building, preventing them from falling further down the gap. Catch platforms must be attached to screens by a system that ensures that they do not dislodge and fall when the screens are lifted. The system must be sufficiently robust to withstand any workplace environment impacts.

Catch platforms must be designed by an engineer to resist impact loads likely to be applied (i.e. from bearers, form ply, props etc). Where chain is used to secure catch platforms, it must meet the requirements of Australian Standards with a known load limit.

## 8. Health concerns

### 8.1 NOISE

Division 10 – Noise of the OHSW Regulations describes what must be done to prevent risks from exposure to excessive noise at work. The Approved Codes of Practice under the OHSW Act are:

- *National Code of Practice for Noise Management and Protection of Hearing at Work [NOHSC: 2009 (2004)]*, 3rd Edition (available from the SafeWork SA website at [www.safework.sa.gov.au](http://www.safework.sa.gov.au))
- *AS 1270: 1988 Acoustics – Hearing Protectors*.

The Codes require all workers to be protected from the risk of noise induced hearing loss (NIHL) during their work. If no engineering solution is available, either ear plugs or ear muffs can be used.

Activities such as the erection or dismantling of formwork may involve very loud, metal on metal impact noises, such as using hammers on metal. Such noise can damage hearing immediately because of its high impulsive noise level. Other loud noise, such as that created when using a circular saw, can gradually damage a person’s hearing through longer periods of regular exposure.

The use of the hearing protectors must be enforced where a risk assessment identifies them as the preferred option to control the risk.

Often, construction site management imposes a blanket use of hearing protection across the site at all times. For formwork activities, protection against NIHL by wearing hearing protectors is often the only option.

## **8.2 DUST AND ATMOSPHERIC CONTAMINANTS**

Division 17 – Ventilation of the OHSW Regulations describes obligations that must be met for atmospheric contaminants, including silica dust.

While concrete itself is not a hazardous substance, high levels of silica dust can be produced during formwork processes. Silica dust is a hazardous substance generated when power tools cut, grind, chip, scrape, crush or blast materials such as concrete. Silica dust may also be created, to a lesser degree, by sweeping or cleaning when dismantling building equipment or during demolition work.

The visibility of dust does not necessarily provide an accurate measure of the degree of risk. Highly visible dust caused by earthmoving equipment on building sites or other earthworks sites is unlikely to contain hazardous levels of respirable silica dust. However, silica dust produced by other activities may be at hazardous levels even though it is barely visible.

All reasonable steps must be taken to minimise the exposure to silica dust. Silica dust that is generated during formwork can be controlled by:

- using dust extraction or a wet process as a dust suppressant engineering control
- providing respirators (as a last resort) where dust is likely to exceed permissible levels.

## **8.3 MANUAL TASKS**

In 2008/09, there were more than 2,270 workers compensation claims in the construction industry. These resulted in more than \$13.3 million in compensation costs and over 38,000 days of lost time. The industry's uninsurable costs associated with these injuries would have amounted to more than \$53 million.

Of the injuries, 730 (32%) were musculoskeletal injuries from manual tasks. The cost of compensation from these injuries was \$5.3 million (41% of total costs) and more than 17,700 working days have been lost (47% of total lost time). The uninsurable cost to the industry to date for musculoskeletal injuries occurring in 2008/09 has amounted to more than \$21.5 million.

In all its activities such as planning, transport, storage, erection and dismantling of formwork and scaffolding, the industry needs to take into account the risk of injury from manual tasks and develop strategies to eliminate, or if this is not practicable, at least minimise the risks from manual tasks.

The *Approved Code of Practice for Manual Handling* (available from the SafeWork SA website [www.safework.sa.gov.au](http://www.safework.sa.gov.au)) provides

information about preventing or minimising exposure to risks that contribute to or aggravate work-related musculoskeletal disorders. There are also many other sources of information for solutions to manual task risks available through websites in all other Australian jurisdictions, and globally in the UK ([www.hse.gov.uk](http://www.hse.gov.uk)), Europe (<http://osha.europa.eu/en>) and Canada (<http://www.ccohs.ca/>).

# APPENDICES

## Appendix 1: Definitions

### **Bearer**

Primary horizontal support members for a formwork deck that are placed in U-heads on top of formwork frames. Bearers are usually constructed from timber but are sometimes constructed from metal, such as in the case of some modular formwork systems.

### **Cell**

Part of a slip form, jump form or crane-lifted form where workers are required to carry out work. The cell will generally be enclosed by all sides and a bottom surface.

### **Certificate of competency**

A document that has been issued by a licensing authority prior to the introduction of the *National Standard for Licensing Persons Performing High Risk Work* authorising a person to perform one or more classes of high risk work.

### **Class of high risk work**

A class of work listed in the Schedule – Licence Classes and Definitions, of the *National Standard for Licensing Persons Performing High Risk Work*.

### **Competent person**

In relation to performing an inspection or other task for a control measure – is a person who has acquired, through training, qualifications or experience, the knowledge and skills to do the work in a safe way, including:

- (i) sound knowledge of relevant Australian Standards, codes of practice and other legislation; and
- (ii) sound knowledge of, and competence in, the risk management process for erecting, altering and dismantling formwork, including –
  - hazard identification and risk assessment
  - measures to control exposure to risks
  - safe work practices and procedures, and
  - how to plan and prepare formwork.

### **Containment sheeting**

A protective structure fixed to the perimeter of the building, structure or working platform to contain objects and prevent them from falling.

### **Edge protection**

A barrier erected along the edge of –

- a building or other structure
- an opening in a surface of a building or other structure, or
- a raised platform

to prevent a person falling.

### **Engineer**

In relation to the performance of a task, means a person who –

- (a) is a registered professional engineer eligible for corporate membership of Engineers Australia, and
- (b) is competent to perform the task.

### **False deck**

A deck designed to prevent workers falling 2 m or more and/or provided as a working platform.

### **Form**

An object used in the casting of concrete floors, walls or columns that has part of its surface in contact with the concrete during the initial concrete curing process.

### **Formwork designer**

A person competent to design basic or non-basic formwork systems, but may only certify basic formwork. To certify non-basic formwork, the Formwork Designer must be an engineer experienced in formwork design.

### **Formwork frame**

A structural assembly, a number of which are used to support a formwork deck. Bearers are placed directly on these frames.

### **Horizontal member**

Any horizontal member of a formwork or scaffold frame that is provided as stiffening for the frame and may also be used to support a working platform (includes the term 'transom' in reference to scaffolding).

### **Intermediate platform**

A platform at least two planks wide, located less than 2 m above a continuous deck.

### **Joist**

A secondary horizontal support member for the formwork deck that is placed on top of, and at right angles to, the bearers. Joists are usually constructed from timber but are sometimes constructed from metal, such as in the case of some modular formwork systems.

### **Metal deck**

A form deck, made of steel sheets that are normally not recovered.

### **Modular formwork**

A formwork system that is specifically designed and consists of components that are not intended to be used with other systems.

### **Perimeter edge**

Edge protection that is provided on the perimeter of the protection formwork to be erected.

(Note: Perimeter edge protection will prevent a fall from the outside perimeter of the formwork but will not prevent internal falls through the formwork).

### **Propping**

Slender structural members placed in a vertical position between two horizontal surfaces and used to support the upper surface. The proprietary term 'acrow' is often used to describe a prop. The height of propping is usually adjustable.

### **Vertical member**

A vertical structural member which may or may not form part of a frame, also known as a standard, prop or vertical tube.

## **Appendix 2: Training**

Under the South Australian *Occupational Health, Safety and Welfare Act 1986, Part 3, Section 19 – Duties of employers*

...“an employer must provide such information, instruction, training and supervision as are reasonably necessary to ensure that each employee is safe from injury and risks to health”...

Anyone involved in erecting and dismantling formwork must be trained to perform their work in a manner that is safe and without risks to health or safety, and must have evidence of their training. The employer must monitor their systems of work and, when necessary, provide refresher training to ensure that safe practices are being followed.

The requirement for an employer to ensure that training is provided has been identified in several sections of this guide. Some of this training relates to specific competencies required under the legislation and must be conducted by a registered training organisation. For example:

- scaffolder
- rigger
- dogman
- crane operation.

Other duty of care training may be provided and delivered by manufacturers or suppliers of equipment and materials or, where resources are available, developed and delivered in-house by competent trainers. This includes training for:

- formwork construction systems
- modular work systems
- working at height harness systems.

Safe work method statements, developed by experienced workers and their supervisors, can form an excellent basis for introductory training for inexperienced or new workers in the following areas:

- erecting of all types of formwork
- dismantling of all types of formwork
- laying of metal deck
- slip forms and jump forms.

Each site manager must assess training requirements and ensure that everyone on-site can competently and safely undertake their work without adversely affecting the health and safety of others.

### Appendix 3: Sample engineer's certification letters

Refer to section 2.2.2 Formwork design certification requirements.

#### (A) Engineer's Certification Letter – **No variation to design**

.....  
.....  
.....  
.....

Dear .....

Project .....

I certify that the formwork system detailed below has been designed in accordance with *AS 3610 – Formwork for Concrete* and *AS 3600 – Concrete Structures*, and the project documentation including the structural engineering drawings and specifications. The system is detailed on the drawings and documentation listed below.

<b>Drawing number</b>	<b>Drawing name</b>
<b>Specifications</b>	

Yours faithfully

SIGNATURE

Engineer's name

Document Control System No.



(B) Engineer's Certification Letter – **Variation to design**

.....  
.....  
.....  
.....

Dear .....

Project .....

I certify that the variations to the formwork system detailed below have been checked and satisfy the *AS 3610 – Formwork for Concrete*, *AS 3600 – Concrete Structure* and the project documentation including the structural engineering drawings and specification.

<b>Variation number</b>	<b>Details of variation of formwork system</b>	<b>Project drawing reference</b>

Yours faithfully

SIGNATURE  
Engineer's name

Document Control System No.

## Appendix 4: Construction checklist

*(Note: '#' denotes an item that, if not passed by the competent person, must be referred to the engineer. All other items not passed by the competent person must be corrected on-site and certified by the competent person when he/she is satisfied.)*

### Loads

- Stacked load limits are identified for all stages?
- Stacked materials are on spreaders?
- # Will any construction procedures exceed the stacked load limit?

### Materials

- # Correct form materials are being used?
- Form face condition is suitable for the finish required?

### Formwork frames

- # Are the formwork frames in the correct location and correct number?
- Are they to dimension and within tolerance?
- Are they accurate to line, level and plumb?

### Bracing/Props

- # Are there different props or braces to the ones indicated on the formwork drawings?
- Are the props plumb?
- Are props straight?
- Are base plates on adequate foundations?
- Are all loads centrally placed?
- If no, are all eccentric loads certified?
- Are supported elements wedged and nailed?
- Is the bracing correct and firmly connected?

### Fixing

- Is the nailing/screwing adequate?
- # Are the ties the correct type?
- # Are they on the correct grid?
- Are all ties, clamps and bolts tight?
- Are wedges tight and nailed?
- # Are any connections between traditional formwork and modular formwork correct?

### Back-propping

- # Is the back-propping system correct?
- # Are the number of floors required for back-propping correct?
- # Has the propping been correctly released and tightened, as specified, prior to the concrete being poured above?

### Cleanliness

- Are the form faces cleaned?
- Is any damage correctly repaired?
- Is the correct release agent in use?
- Is it being correctly applied?
- Has all debris been removed from within the form?

### Watertightness

- Are all form panel joints properly sealed and cramped?
- Are the construction joints sealed?

### Concrete/Concreting

- What is the maximum rate of placement permitted?
- Are the forms maintaining line, level, plumb, shape, etc during concreting?

### Stripping

- What are the minimum stripping times?
- Has the project designer permitted modification of these?
- Do the procedures enable stripping without damage to form or concrete?
- Are the provisions consistent with the re-use times required?
- Does the crane have the necessary slings etc to move the forms quickly?
- What curing methods are to be used once the formwork is removed?
- Is the storage area for the formwork organised?

### Safety

- Are there adequate guardrails, handrails, walkways, signs, etc in position?

## Appendix 5: Sample structural (pre-pour) certificate

Refer to section 2.2.5 On-site coordination and verification

Engineer's/Competent person's name: ..... Telephone: .....

Address: .....

Fax: .....

Mobile: ..... Date: .....

Project: .....

.....

Level: ..... Area: .....

This is to certify that the ..... Formwork for the above project has been inspected and is considered to be adequate to support the design loads in accordance with the relevant Australian Standards including *AS 3610 Formwork of Concrete*.

The following items were included in the inspection:

Item	Condition (circle)	Work required (circle)	Details of remedial work required
Base plates	PASS FAIL	No Yes	
Frame spacing	PASS FAIL	No Yes	
Frame bracing	PASS FAIL	No Yes	
Frame extensions	PASS FAIL	No Yes	
Bearer size and spacing	PASS FAIL	No Yes	
Joist size and spacing	PASS FAIL	No Yes	
Prop spacing	PASS FAIL	No Yes	
Prop bracing	PASS FAIL	No Yes	
Eccentric loading	PASS FAIL	No Yes	
Prop inclination	PASS FAIL	No Yes	
Timber condition	PASS FAIL	No Yes	
Steel condition	PASS FAIL	No Yes	
Nails in plates as required	PASS FAIL	No Yes	
Column framing	PASS FAIL	No Yes	
Column bracing	PASS FAIL	No Yes	
Plywood fixing	PASS FAIL	No Yes	

.....  
Engineer's/Competent person's name

.....  
Signature

## Appendix 6: Defects commonly found in formwork systems

### Sole plates

- (a) Not levelled in or eccentrically placed
- (b) Inadequate load-carrying capacity of the ground, or uneven bedding
- (c) Deterioration with time, e.g. due to weather conditions
- (d) Deterioration of load-carrying capacity of the ground, e.g. washouts
- (e) Crushing due to inadequate load distribution from vertical and horizontal members.

### Horizontal supports

- (a) Folding wedges, taper cut too coarse, not properly cleated or cut from wet material
- (b) Inadequate lateral and torsion bracing, e.g. between telescopic centres, centres carrying heavy loads over long spans, steel props supporting heavy loads at, or near, maximum extension and between towers supporting independent spans
- (c) Horizontal members not centrally placed in U-heads
- (d) Inadequate supports to cantilevers, e.g. struts supporting deep beam sides on the outer face of the structure
- (e) Inadequate bearing areas to vertical supports and underside of principal members causing crushing
- (f) Inadequate support to prevent overturning of deep principal members because stirrups or U-heads omitted
- (g) Bolted timber connections not staggered creating tendency to split out.

### Vertical supports

- (a) Inadequate bracing during erection
- (b) Supports not plumb
- (c) Inadequate lateral ties and/or vertical and plan bracing
- (d) No ties between standards at point of loading (most important where telescopic centres are being supported)
- (e) Incorrect provision of props from floor to floor
- (f) Lack of rigidity of screw connections due to over-extension or lack of bracing
- (g) Incorrect pins used in adjustable steel props, e.g. nails, mild-steel bolts and reinforcing bars used
- (h) Scaffold U-heads or supports omitted or otherwise eccentrically loaded without allowance having been made for this condition
- (i) Bearing plates distorted (top and bottom plates of steel props)
- (j) Inadequate or discontinuous bracing to scaffold
- (k) Base jacks over-extended.

### General

- (a) Excessive tolerances in construction
- (b) Failure to check tightness of bolts, wedges, etc
- (c) Failure to control vertical rate of placement of concrete
- (d) Failure to control placement of concrete, causing uneven loading of forms
- (e) Inadequate allowance for uplift of concrete under inclined forms
- (f) Inadequate allowance for the effects of vibration on joints
- (g) Inadequate allowance for stresses induced by pre-stressing, temperature and moisture movements
- (h) No allowance for wind loading
- (i) No allowance for the effect of vibration on ties, struts, braces, and wedges
- (j) Unrealistic assessment of stresses due to over-simplification of design assumptions
- (k) Unequal load distribution between two or more members carrying a common load
- (l) Penetrations to metal decks to be supported.

## **SAFEWORK SA**

[www.safework.sa.gov.au](http://www.safework.sa.gov.au)

### **HELP CENTRE 1300 365 255**

Email: [help@safework.sa.gov.au](mailto:help@safework.sa.gov.au)

(the Help Centre closes at 4.15pm on Wednesdays)

To report all serious workplace injuries and incidents telephone  
**1800 777 209** (24-hour service).

---

### **LIBRARY AND BOOKSHOP**

Ground floor, State Administration Centre

200 Victoria Square, Adelaide

Opening hours: 8.30am – 5pm, Monday to Friday

#### **LIBRARY**

Telephone: **(08) 8204 8877**

Facsimile: (08) 8204 8883

Email: [library@safework.sa.gov.au](mailto:library@safework.sa.gov.au)

#### **BOOKSHOP**

Telephone: **(08) 8204 8881**

Facsimile: (08) 8204 8883

Email: [bookshop@safework.sa.gov.au](mailto:bookshop@safework.sa.gov.au)

---

## **OFFICES**

### **HEAD OFFICE**

Level 4, 33 Richmond Road, Keswick

GPO Box 465, Adelaide, SA 5001

DX 715, Adelaide

### **REGIONAL OFFICES**

Located at Berri, Mount Gambier,

Port Lincoln, Port Pirie and Whyalla.

Telephone: **1300 365 255**

---

### **FREE INTERPRETING SERVICE**

Telephone the Interpreting and Translating Centre

on **(08) 8226 1990** and ask them to contact SafeWork SA.

### **HEARING AND SPEECH ASSISTANCE**

Contact us through the National Relay Service and ask  
for SafeWork SA 1300 365 255.

- for TTY/Voice: **133 677**
- Speak and Listen: **1300 555 727**
- [www.relayservice.com.au](http://www.relayservice.com.au)