

MICROGRIDS ARE BEING DEPLOYED AT A RISING RATE, PRIMARILY as a means of increasing power system resilience. Commonly, a microgrid today includes at least some inverter-based resources (IBRs), and many microgrids have modes or conditions under which they are entirely energized by IBRs. Most microgrids today are deployed on radial distribution circuits, but it is conceivable that they could also be considered for deployment on secondary network systems.

Under faulted conditions, IBRs have significantly different behavior from rotating machines, and this difference introduces new challenges for microgrid protection system design. The fault current properties of IBRs create a significant difference in the fault current profile between grid-connected and microgrid-islanded modes and between IBR-dominant or rotating machine-dominant configurations. These variations also impact the conventional phasor-domain short circuit analysis used to design such systems.

This article is the first in a two-part series on the influence of IBRs on microgrid protection. In part one, the focus is on microgrids deployed on radial circuits. This article discusses some of the challenges related to the protection of IBR-based microgrids and presents some ongoing research and solutions in the area. The different controls



Influence of Inverter-Based Resources on Microgrid Protection

Part 1:
Microgrids in
Radial Distribution
Systems

Digital Object Identifier 10.1109/MPE.2021.3057951
Date of current version: 19 April 2021



By Matthew J. Reno, Sukumar Brahma, Ali Bidram, and Michael E. Ropp

for IBRs (i.e., grid forming and grid following) are discussed to present how their short current signatures and dynamic response under faults impact microgrid protection.

Challenges in Microgrid Protection

Recently, microgrids have gained much attention in the electric power industry due to 1) their capability for improving power system reliability and resiliency, 2) their impact on increasing the use of renewable resources, 3) the reduced cost of distributed energy resource (DER) equipment, and 4) the continuing evolution of applicable codes and standards. As a result, it is expected that microgrid deployment worldwide will grow significantly over the next several years. Most microgrids today are created by reconfiguring systems that started as radial distribution systems at the facility or community level.

Small conventional generators (e.g., diesel and natural gas) remain important in microgrids due to their performance properties, relatively low cost, and availability. However, most microgrids today obtain at least some fraction of their energy from variable-generation resources like photovoltaics (PVs), and energy storage systems (ESSs) are becoming nearly ubiquitous in microgrids, as they allow the optimal operation of small generators as well as higher integration of variable-generation resources, and they can be used to improve the system's performance when transitioning from on-grid to off-grid mode.

Nearly all renewable energy systems and ESSs are IBRs, meaning that they are connected to the ac power system via a dc-ac converter called an inverter (the term *inverter* is commonly used even for the bidirectional dc-ac converters used in ESSs). The inverter's behavior is largely software defined, providing a high level of flexibility as well as unique performance characteristics and opportunities. Today, there are microgrids in operation that are energized entirely by IBRs, and even those that include rotating generators are often operated in IBR-only modes under certain conditions.

Microgrids, like all power systems, require protection that de-energizes and isolates faults before they can harm health or property. The protection of traditional distribution systems is designed with the underlying assumption that the system is fed by one source (a substation) and has a radial topology. They are protected by overcurrent functions and devices. However, two key challenges arise in

protecting circuit elements in IBR-based microgrids in this way.

- 1) Microgrids can be fed by multiple distributed sources. The protection of conductors, transformers, and other circuit elements must thus be designed for any feasible combination of sources, and fault current directions and magnitudes may change accordingly.
- 2) The fault current produced by IBRs does not lend itself easily to traditional overcurrent methods of fault detection and isolation.
 - The semiconductor switching devices of inverters are intolerant of overcurrent, requiring IBRs to limit their fault current contributions to, typically, on the order of 1.1–1.5 per unit (pu) of the inverter's nominal current rating. IBRs do not produce the large fault currents typical of utility sources or synchronous generators.
 - IBRs often limit their fault current using means that cause the output waveform to be nonsinusoidal. The harmonic content in the waveform will generally be IBR specific, as it depends on how the firmware achieves the current limiting. Protection systems must be tolerant of this harmonic content.
 - The phase angle between the IBR's fundamental output current and fundamental terminal voltage is set by the IBR's programming, and, thus, there are no generic means for predicting it.

This article addresses the challenges related to the protection of inverter-based microgrids and reviews some ongoing research and solutions in the area. Different types of IBR topologies and controls are elaborated, and the challenges of inverter-based microgrid protection are highlighted. The solutions for the protection of microgrids with a high penetration of IBRs are discussed.

IBR Overview

The behavior of IBRs under faulted conditions is strongly determined by the inverters that interface the primary power source (i.e., renewable energy sources or ESSs) to the ac system. In this section, some fundamentals of inverters are briefly reviewed to provide background.

Topologies

In general, inverters are divided into single- and three-phase categories. Single-phase inverters are mostly used for lower-power applications (typically fewer than 15 kW) and in single-phase microgrids. Three-phase inverters are used to integrate larger generation sources to the primary

systems (i.e., the portion of the system that operates at the microgrid’s primary voltage).

Single-Phase Inverter Topology

A basic inverter circuit topology called an H-bridge is shown in Figure 1. The inverter itself comprises four switches, S_1 – S_4 , and an inductor–capacitor (LC) low-pass filter. This inverter is serving a resistive load R and, thus, is shown in an off-grid mode, in which case it would be operated as a grid-forming inverter.

Three-Phase Inverter Topology

A three-phase H-bridge inverter connected to a larger utility is shown in Figure 2. The inverter now has six switches, S_1 – S_6 . The dc voltage V_b is required to be larger than the peak of the ac voltage on the inverter output terminals. When there is a utility voltage source on the right, this inverter does not regulate the magnitude and frequency of its output voltage, as those are controlled by the utility grid. Instead, the inverter is operated in the so-called grid-following mode. Most inverters using the topology shown in Figure 2 require that the transformer between the IBR and grid be ungrounded on the IBR side. This can have a significant impact on protection

because an ungrounded transformer blocks grid-side zero-sequence voltages from reaching the inverter, and, thus, the inverter’s built-in protection cannot “see” these. The transformer itself will impact the zero-sequence current available during asymmetrical faults.

Many commercial inverters today use a more complex circuit topology called a neutral-point-clamped (NPC) converter. NPC converters have differences in their faulted behaviors from the standard H-bridge configuration. For example, an NPC converter does not require that the transformer between the IBR and grid be ungrounded on the IBR side, so a transformer can be used through which the inverter can “see” and respond to zero-sequence voltages from the grid side. Details of the types and operation of NPC converters can be found in the “For Further Reading” section of this article.

Types of Inverter Controls

Inverter controls can be broadly grouped into two main categories of grid-forming and grid-following inverters. These are described in Table 1, and block diagrams of each type are shown in Figure 3.

Grid-forming inverters regulate voltage and frequency at their point of interconnection. When there are multiple sources sharing responsibility for frequency regulation, frequency droops are commonly used, which provide a slope of the frequency setpoint versus the power output from the generator. The frequency droop ensures the frequency stability of the microgrid while sharing active power among IBRs. Grid-forming inverters are also equipped with voltage droops to accommodate a coordinated voltage regulation in the microgrid while sharing reactive power among IBRs. Grid-following inverters are equipped only with power and current control loops, which facilitate their operation as controllable sources of active and reactive power.

Devices and Materials

The switch type and semiconductor switch material used in an inverter impact the types of protection possible in power systems energized by that inverter. The most commonly used controlled switches in today’s inverters are silicon insulated-gate bipolar and metal–oxide–semiconductor field-effect transistors.

Silicon has a bandgap of about 1.1 eV. It is abundant and well understood, and processing techniques are highly mature. However, the material properties impose certain limitations on the performance of silicon switching devices. Switches made from semiconductors with

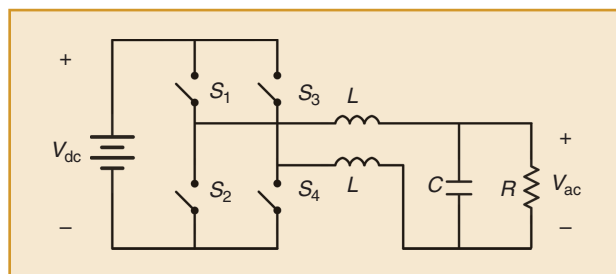

figure 1. A diagram of a single-phase H-bridge inverter.

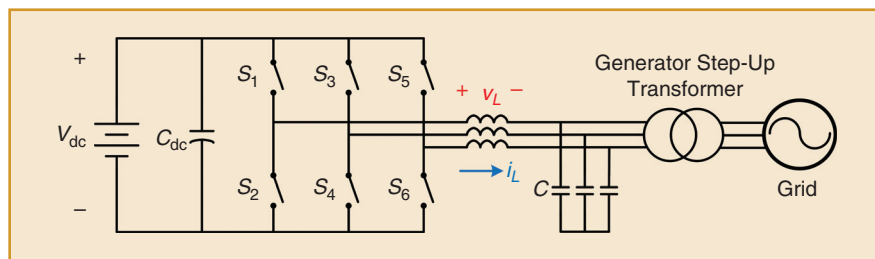

figure 2. A three-phase H-bridge inverter connected to a utility grid.

table 1. The types of inverter controls.

Category	Application	Regulated Quantities	Appearance to the Rest of the System
Grid following	Connecting to a power system regulated by other generation resources	Magnitude of the active and reactive power injection	Power-controlled current source with limits
Grid forming	Connecting to a power system in which the system must be regulated by the inverter	Magnitude and frequency of the voltage	Regulated voltage source with current limits

The inverter's behavior is largely software defined, providing a high level of flexibility as well as unique performance characteristics and opportunities.

wider bandgaps, such as silicon carbide (2.3–3.3 eV) and gallium nitride (3.4 eV), could have significantly higher operating voltages, higher operating temperatures, lower on-state resistances, and faster device switching.

Higher-frequency switching and higher-voltage operation are especially desirable for power electronics. The higher switching frequency permits the use of smaller components in the low-pass filter that extracts the 60-Hz component from the switched waveform, and higher-voltage operation can lead to greater operating efficiency through reduced resistive losses and new application opportunities for solid-state transformers. These advantages likely will cause wide bandgap use in inverters to accelerate.

Higher switching frequencies could lead to more precise control over individual pulses of energy injected from the inverter into the power system, and that precision of control could one day facilitate the development of novel protection techniques in IBR-energized systems. However, the trend toward higher-voltage converters might also lead to lower-current designs that would further reduce the fault

current available from IBRs and potentially make protection more challenging.

Challenges Posed by IBRs for Microgrid Protection

DERs in general, and IBRs in particular, pose different challenges to the protection system. At the distribution system level, they can cause several issues, such as sympathetic tripping, coordination loss, protection blinding, and failed autoreclosing. In general, the challenges associated with protecting IBR-based systems stem from the fact that IBRs do not exhibit conventional synchronous-machine short circuit behavior, including transient, subtransient, and steady-state responses. In the following sections, we elaborate on the protection challenges associated with IBRs in more detail.

IBR Fault Current Signatures

The reliance of IBRs on semiconductor switches and the fact that IBR fault currents are largely determined by their nested

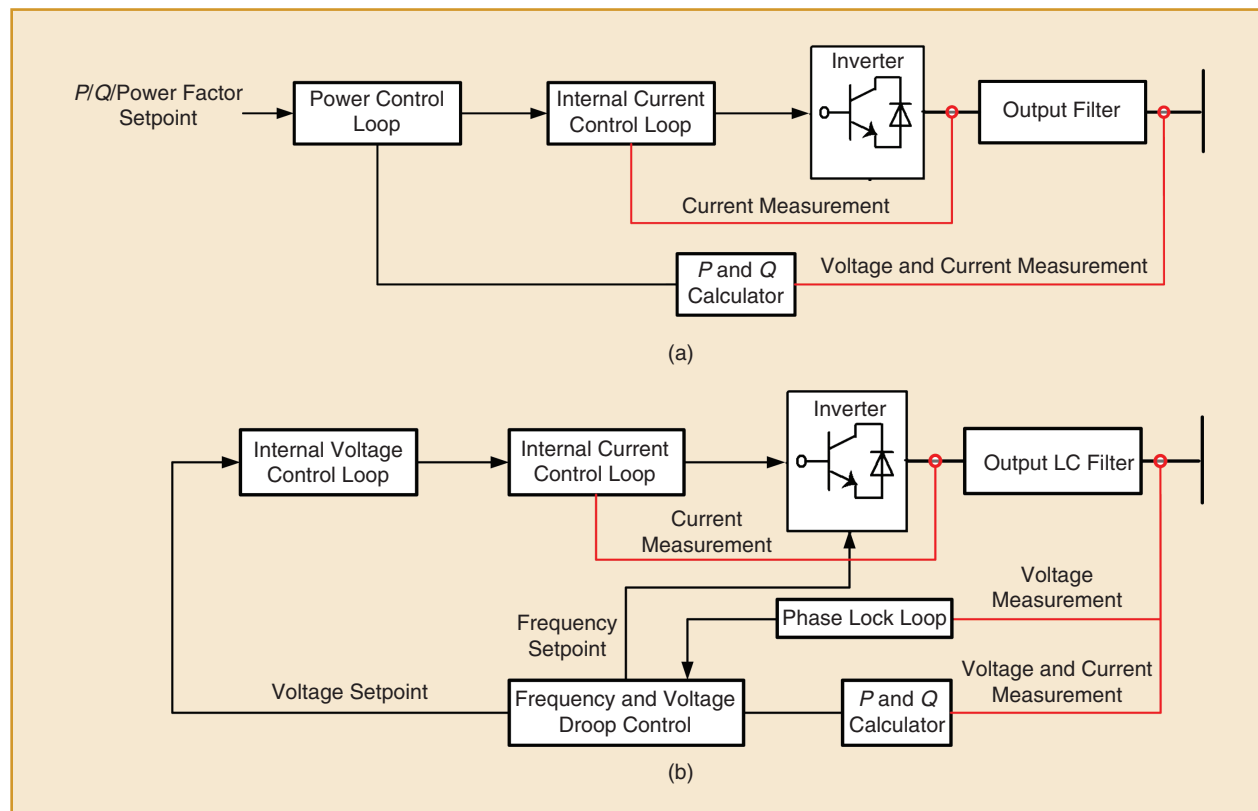

figure 3. IBR control diagrams: (a) grid-following and (b) grid-forming inverters.

Microgrids, like all power systems, require protection that de-energizes and isolates faults before they can harm health or property.

control systems lead to IBRs having specific fault current signatures. These unique features include the following.

Limited Fault Current Magnitude

To protect semiconductor switches, most inverters include both hardware and software switch current limiters that keep the IBRs' fault current level low. The maximum steady-state fault current produced depends on design parameters and varies from one IBR to another. Once a fault is applied, the inverter current exhibits a very short transient (lasting fewer than two 60-Hz cycles) and then returns to a steady-state fault current that is typically around 1.1–1.5 pu of the inverter's current rating. This is generally true whether an inverter is grid forming or grid following.

The fault current transients depend on the inverter controllers as well as the thermal rating of power electronics switches. Some inverter manufacturers are working on increasing the magnitude and duration of the fault current (especially for islanded grid-forming inverters), but even at 2–3 pu fault current, it can be difficult to distinguish in-rush or motor-start events from a fault condition.

Control-Determined Current–Voltage Phase Angle

When a fault occurs that causes the IBR terminal voltage to become low, the magnitude of the fault current produced by grid-forming and grid-following inverters is essentially the same. Both types will reach the inverter's current limit and hold there, as explained earlier, but the current–voltage phase angles may be significantly different.

For example, a grid-forming inverter will increase the magnitude of its output current as part of its effort to reacquire its voltage setpoint, and, at the same time it will in general move toward higher current–voltage phase angles (higher reactive power). In contrast, a grid-following inverter increases its output current magnitude as it attempts to reacquire its active power setpoint, but while it is still on-grid, the current–voltage phase angle will be set by the IBR's reactive-power programming, which may set a limit anywhere from zero to the IBR's reactive power limit.

When a grid-following inverter is isolated on a faulted system, the IBR will change its frequency as it attempts to adjust its current–voltage phase angle, and this frequency change will typically be sufficient to trip the grid-following IBR, but it may also interfere with fixed-frequency root mean square measurements. Furthermore, if multiple IBRs all are providing reactive power support

but have different time constants, they may interact with one another.

Different Sequence Components

In grid-following IBRs, the control loops are designed to suppress the negative-sequence current component, resulting in negative-sequence currents that are typically less than 10% of the positive-sequence value, which can cause protection systems to behave unpredictably. Grid-forming inverters can generally inject higher levels of negative-sequence currents for unbalanced grid operation, but not all inverters in the microgrid may be controlled this way, which can make predicting inverter fault current contribution and protection design challenging.

Nonlinear Fault Current Contribution

Inverter fault current limiters also make the fault currents nonlinear. This can impact the conventional phasor-domain short circuit analysis, which relies on the linear-equivalent Thevenin model of sources. Moreover, many inverters limit their peak output currents by manipulating the pulsewidth modulation to lower the peaks of the output current, resulting in a flat-topped waveform. The unwanted harmonics on the voltage and current values can lead to challenges in calculating their fundamental values.

Importantly, grid-forming inverters used for microgrid or off-grid applications may be designed to produce negative- and zero-sequence currents. Unlike typical grid-following PV inverters, to support unbalanced microgrid applications, grid-forming inverters control voltage and frequency instead of limiting negative-sequence injections. For example, in Figure 4, for a single-line-to-ground fault, conventional protection designs expect that zero-sequence current (I_0) equals positive-sequence current (I_1) equals negative-sequence current (I_2). For a grid-following inverter, there is no zero sequence current and only limited negative-sequence current during the fault because of the inverter controls, but the grid-forming inverter responds as expected for more conventional sequence current injections.

Similar experimental tests were performed for the grid-forming inverter for double-line-to-ground faults, where the inverter I_1 injection equaled the sum of I_0 and I_2 , as expected, and line-to-line faults, where the inverter I_1 current equaled I_2 as expected. This fact can be especially challenging when designing microgrid protection schemes because the inverter-based generation may switch between control

To protect semiconductor switches, most inverters include both hardware and software switch current limiters that keep the IBRs' fault current level low.

modes when the microgrid transitions between grid-connected and islanded operation.

For example, in grid-connected mode, both a PV inverter and an energy storage inverter may use current-controlled grid-following inverter controls with no zero- or negative-sequence injections. During the microgrid transition to islanded operation, the PV inverter will likely stay in grid-following control mode, but the energy storage inverter may be designed to transition to grid-forming mode and, thus, able to inject negative- and zero-sequence current.

Impacts of IBR on Conventional Protection Schemes

The unique fault current characteristics of IBRs can adversely impact the performance of conventional protection schemes.

- ✓ *Impact of IBRs on overcurrent protection:* The low-fault-current contribution from IBRs can adversely impact the operation of overcurrent protection devices. This impact is more salient in an islanded microgrid, where no fault current is supplied from the upstream grid, and the microgrid IBRs are the sole source of fault currents. Under this scenario, the conventional overcurrent devices fail to detect and isolate microgrid faults if the fault current that they sense is below their current pickup settings, and it is difficult to choose overcurrent settings that provide sufficient sensitivity and selectivity.

- ✓ *Impact of IBRs on directional protection:* The potentially unpredictable negative-sequence current of IBRs significantly impacts the performance of protection schemes that highly rely on this quantity, for example, in determining the direction of faults. Moreover, the performance of negative-sequence overcurrent relays that are

used for detecting nonsymmetrical faults is highly compromised under the high penetration of IBRs.

- ✓ *Protection system coordination:* High penetrations of IBRs distributed throughout the system can impact the coordination of fuses, reclosers, and overcurrent protection relays due to the fault current injections from multiple locations. Furthermore, because IBRs will produce, essentially, a fixed current into a fault, there is no decrease in available fault current as a fault becomes more electrically distant from the IBR, and coordination must rely on varying time delays only. Depending on the utility practice, a minimum coordination time interval should be met between primary and backup overcurrent devices, independent of the fault locations, state of the microgrid, or dispatch of the energy sources in the microgrid. The fault currents from the high penetration of IBRs may change the tripping times of primary and backup protection relays and violate the minimum required coordination time interval. IBRs can also adversely impact fuse-saving schemes.

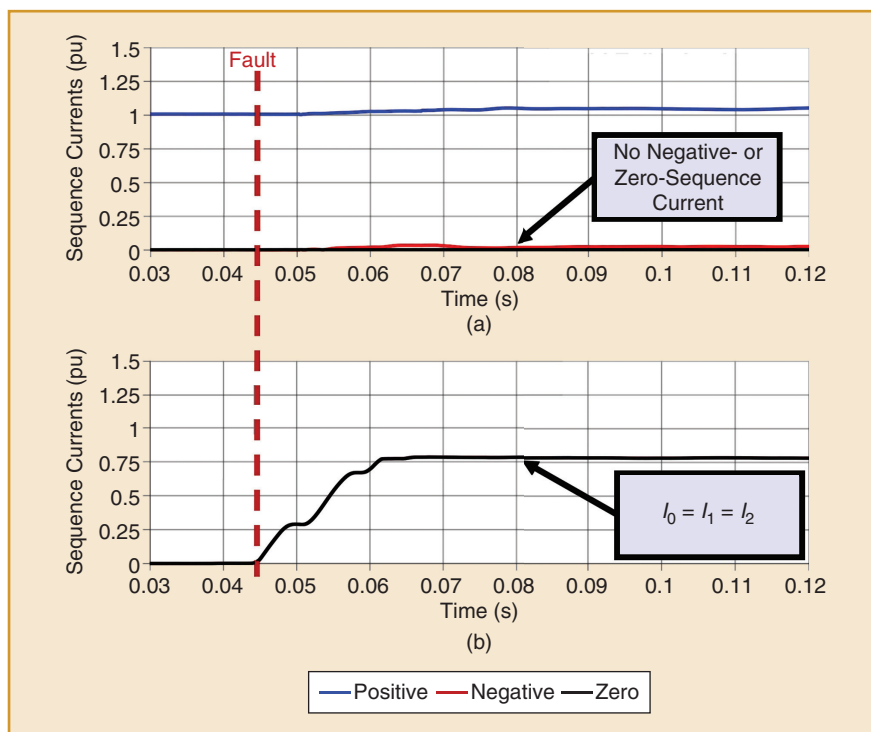

figure 4. The experiment results for a single-line-to-ground fault applied to a three-phase (a) grid-following and (b) grid-forming inverter.

Simulation Challenges for IBR Short Circuit Analysis

The protection system design must be informed by a reliable short circuit study of the microgrid. Conventionally, protection software packages perform short circuit studies in the phasor domain assuming linear Thevenin equivalent short circuit models. Unfortunately, those linearized models tend not to closely represent the fault current behaviors of IBRs. Recent efforts by the IEEE Power & Energy Society's Power System Relaying and Control Committee, under Working Group C24, have helped create phasor-domain short circuit models of IBRs, where IBRs are included in the fault analysis as nonlinear elements defined simply by their output characteristics. Though industrial programs have shown good results with this approach on transmission systems with limited IBR penetration, there are still many challenges with convergence under very high penetration of IBRs and with simulating grid-forming inverters and isolated microgrids.

IBR protection simulation packages can be categorized into iterative and time-domain solutions. In general, to correctly represent IBRs in protection studies, the IBR model in the protection software should be able to

- ✓ model the IBR current limitations with their nonlinearities
- ✓ include different IBR control modes (i.e., grid forming and grid following)
- ✓ account for different IBR reactive power or voltage support control modes (e.g., constant active/reactive power

or constant power factor control modes) in terms of their impact on current–voltage phase angles

- ✓ model the IBR's phase lock loop and droop control characteristics
- ✓ produce proper levels of zero- and negative-sequence fault currents
- ✓ account for the IBR's fault ride-through capability.

Microgrid Protection Solutions for IBRs

Overview of Inverter Operation Under Faults

Figure 5 shows a simulation of a grid-forming inverter in an islanded grid with a line-to-ground fault starting at 8.0 s and removed after 0.15 s. The voltage and current plots at the inverter terminal illustrate that the system recovers to prefault conditions in a reasonable timeframe. Inverter 1 is a grid-forming, 1,500-kVA, 480-V inverter with a current limit of 1.5 pu. The current limit is shown by the light blue line in Figure 5 at a current peak of 3,827 A. Inverter 2 is a grid-following, 1,000-kVA, 480-V inverter with a current limit of 1.1 pu, or a peak current shown in the graph of 1,871 A.

Figure 5 shows that the inverters respond according to design, with the grid-forming inverter 1 providing unbalanced currents both before the fault for the unbalanced load and during the single-line-to-ground fault. On the other hand, the grid-following inverter 2 always provides a balanced current with no negative-sequence current. The inverters are connected with a delta/Yg 480-V/4.16-kV

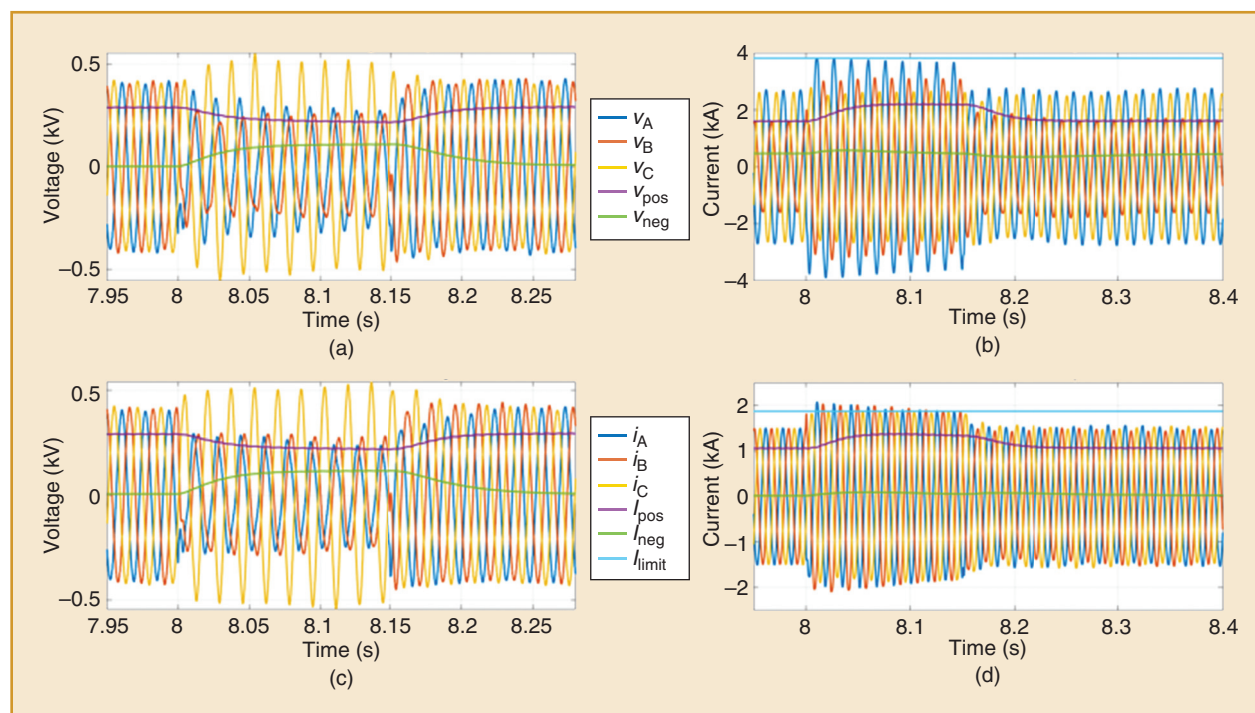

figure 5. Inverter behavior during a phase A to ground fault in islanded mode. (a) Grid-forming inverter terminal voltage, (b) grid-forming inverter output current, (c) grid-following inverter terminal voltage, and (d) grid-following inverter output current.

Importantly, grid-forming inverters used for microgrid or off-grid applications may be designed to produce negative- and zero-sequence currents.

transformer, so the ground fault on phase A results in higher voltages on phase C on the delta inverter side of the transformer. Simulating this fault behavior for the dynamics, sequence currents, and transient voltages is crucial to analyze the protection of microgrids.

Exploring Traditional Protection Options for IBR-Fed Microgrids

There are three objectives to protecting any power system: 1) detecting a fault, 2) determining the location of the fault on the feeder, and 3) de-energizing the fault before equipment is damaged while interrupting the smallest possible number of loads. Traditional distribution system protection schemes achieve all three objectives using coordinated overcurrent protection, the design of which relies on the assumption that the system is radial and fed only from an infinite bus.

An IBR-fed microgrid may have multiple sources, having bidirectional fault currents that are severely limited in magnitude. Therefore, the traditional distribution protection schemes that heavily depend on fuses and reclosers are not expected to work well in IBR-sourced microgrids. For this reason, more sophisticated protection schemes have been explored regarding their suitability for the protection of distribution system microgrids. The suitability of such protection schemes is discussed in the following subsections.

Increasing the Available Fault Current

One of the most straightforward options that can be considered is to increase the microgrid fault current to the point at which coordinated overcurrent protection becomes effective. This solution is most viable in cases in which the microgrid sources are located at one source bus and not distributed throughout the microgrid. One way to increase the fault current frequently used in microgrids today is to install excess inverter capacity (usually twice the expected peak load requirement or more) so that the IBR plant provides substantially higher fault currents. This option can work, but it significantly increases the cost of the IBR plant and microgrid. Another method being actively explored is the use of synchronous condensers as fault-current sources in microgrids. While this approach shows high promise, it also significantly increases costs, and it can have some detrimental effects on microgrid dynamics.

Undervoltage Protection

Undervoltage relaying has attracted some attention because it can be implemented without communications.

However, while undervoltage relaying readily indicates the *existence* of a fault, it does not work well in identifying the fault's location. Figure 6 shows the pu voltages at all buses for phase A-to-ground fault in the IEEE 13-node system.

The change in the voltages at all nodes is large enough to detect a fault in the system, both at the IBR terminal or at any bus in the system. However, the values of the voltages at all buses are very similar. The differences in the highest and lowest voltage magnitudes are about 2% for the A-G fault, 2.3% for the three-phase fault, and 3.1% for the A-B fault. This difference is too small to provide a reliable means of discerning the fault location. Voltages are so close because physics dictates the voltage at the fault point be drawn to a low value, and the system currents are quite small, so the voltage drops across feeders are quite small. This creates a situation where a fault anywhere in the system will be certainly sensed through undervoltage at every bus, but no discrimination is available to identify the faulted section.

Distance Protection

Distance protection works well in transmission and is attractive because it can be implemented without communications, but it is generally difficult to apply in distribution even when there is no microgrid. For example, it is usually challenging to use distance protection for feeders with laterals due to problems of overreach into protective zones at different impedances. In a branching radial distribution system, the recloser protection zone may extend only a short distance to a fuse on one lateral but much farther down a different lateral before the next protective device. Since the boundaries of all taps inside the protective zone are not equal distances or impedances,

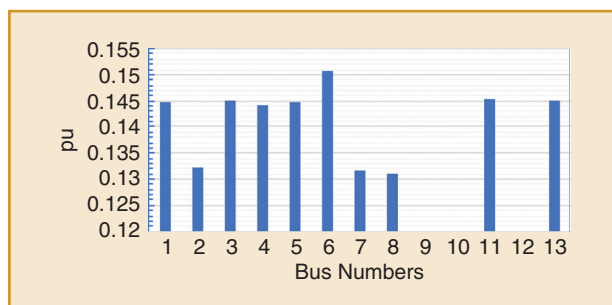

figure 6. The phase A voltages throughout the IEEE 13-node system for a phase A-to-ground fault.

the distance protection will underreach or overreach different branches.

Another challenge with distance protection is that distributed load along the length of the feeder causes the error to be even larger. With any sort of load or generation inside the protective zone, the distance to the fault will be miscalculated because distance protection assumes that impedance to the fault can be calculated using its voltage and current, which does not account for other current flows into the fault or protection zone.

Moreover, a highly unbalanced system can cause issues with load encroachment into the distance protection zone, challenges for the directional elements with unbalance, and errors in the impedance calculations performed in distance relays. For example, for a phase A to phase B line-to-line fault, the impedance calculation would calculate the difference in voltage between phases A and B divided by the difference in current between A and B to calculate the impedance to the fault. This type of calculation does not work if there is an unbalanced load that creates a nonzero difference in the current between A and B.

Differential Protection

Figure 7 shows the currents measured at two locations in a microgrid used for differential protection by subtracting the

currents at the sending and receiving ends of the line. Note that the current is unbalanced before the fault due to unbalanced loads in the microgrid. Also, there are some loads in between the two sensors, so the difference is not exactly zero before the fault. When a line-to-line fault (phase A to phase B) is applied inside the protection zone at 0.9 s, the low-fault-current IBR-based microgrid does not increase currents significantly at the receiving or sending end, but the fault appears in the difference.

There is excellent current discrimination provided by the differential principle, despite the distributed load. This method is found to be the most reliable in both detecting the fault and locating the faulted section. Since it works for low fault currents from both ends, it would obviously work in the grid-connected mode or with synchronous sources in the system since these would provide much higher fault currents. Depending on the size and amount of load inside the differential protection zone, the differential can still have challenges in islanded inverter-based systems, where the fault current may be only a few times higher than the load inside the zone.

The example shown in Figure 7 is a true differential scheme in which the current at one end of the zone is subtracted from the current at the other. While effective, this scheme requires high-speed data communications between

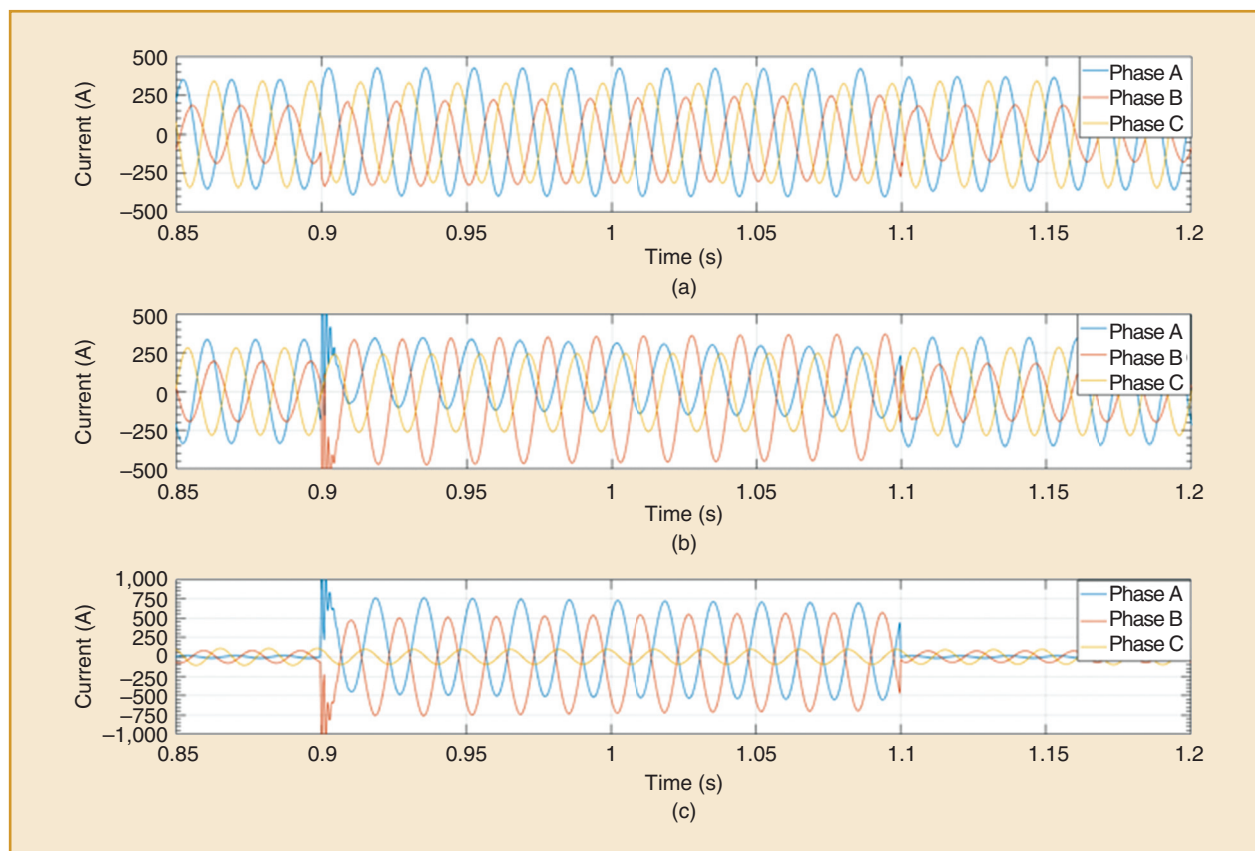

figure 7. The currents for a phase A to phase B line-to-line fault inside a differential protection zone when an IBR-based microgrid is in island mode: the (a) sending end, (b) receiving end, and (c) differential currents.

the end points. In distribution systems, differential protection is typically implemented in the form of a fault location, isolation, and service restoration (FLISR) system. In most FLISR systems, the end points of the protected zones transmit only a status flag indicating whether a fault current was detected at that location, reducing the demands on the communications system.

Indications are that this method will work well in IBR-sourced microgrids, but FLISR requires a communications network as well as breakers, relays, and associated transducers at both ends of every protected zone. For this reason, a FLISR system that provides a high degree of accuracy in fault location and minimizes the amount of load being interrupted can become quite expensive.

Adaptive Protection

One of the promising solutions to address the protection of microgrids is adaptive protection. It is a real-time system that can modify protective actions according to changes in the system's condition. More specifically, in microgrids, adaptive protection can change the protection scheme and settings during mode changes from grid-connected to islanded operation with updated short circuit current values depending on if the grid is available to provide higher levels of fault current.

To this end, the settings of the protection relays should change immediately after the islanding happens (e.g., the pickup of the overcurrent protection relays should be much lower than the grid-connected mode). Adaptive protection can significantly help with protecting the microgrid during and after the transition from grid-connected to islanded mode.

The conceptual design of microgrid adaptive protection is illustrated in Figure 8. The adaptive protection relies on the microgrid communication network to 1) monitor the latest status of the microgrid (e.g., tie-line, IBR, and local circuit breaker statuses; the latest protection relay settings; and so on) and 2) send the modified settings to the protection relays once a system condition change is detected.

Adaptive protection can be added as a module to the microgrid control center. The adaptive protection module contains the short circuit model of the microgrid and updates it in real time using the latest monitored information. Once the short circuit model is updated, different approaches, including logic, model, or learning schemes, can be utilized to find new settings for the protection relays.

Effectively Protecting IBR-Fed Microgrids

Many conventional protection methods, such as coordinated overcurrent, directional relaying, or distance relaying, may not be reliable in microgrids energized by IBRs or even by multiple distributed rotating machines. Differential protection can work equally well in grid-connected and islanded modes, even in the presence of distributed load along feeders, but the cost of upgrade for implementing differential protection can be prohibitive. Differential protection requires breakers at both ends of every protected zone, associated current transformers and relays, and high-speed communications between them. Absorbing this expense is an issue not addressed in the current financial models used by utilities.

To alleviate this concern, a suboptimal form of differential protection can be adopted at the cost of selectivity.

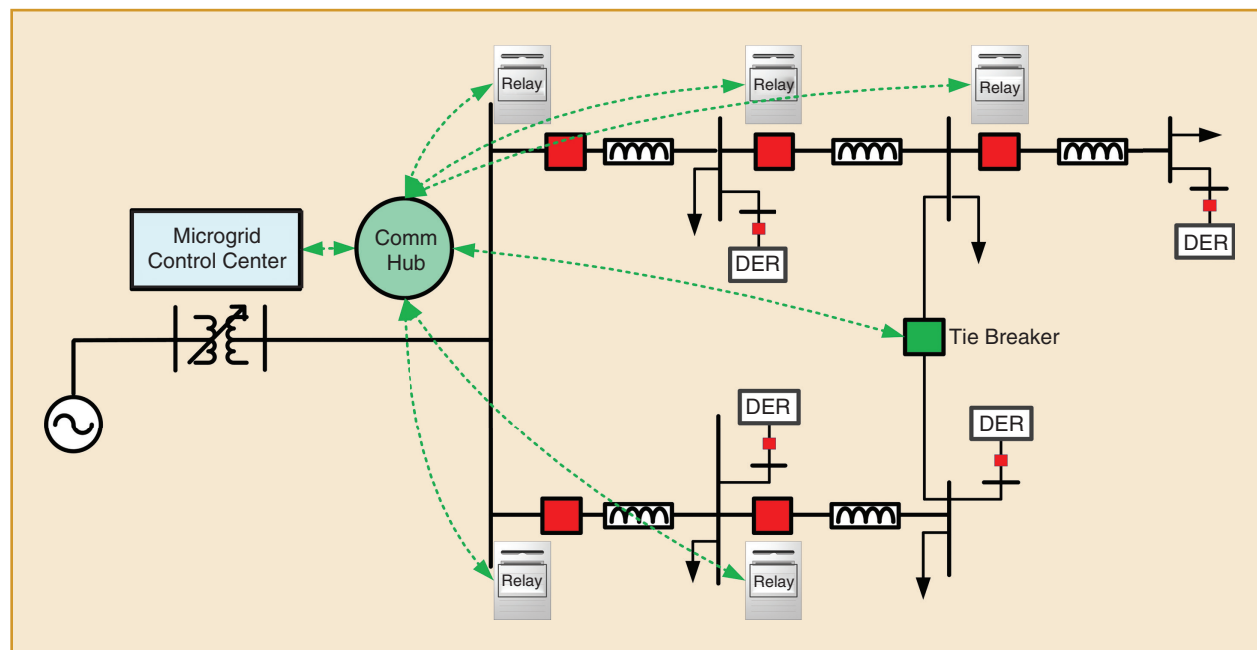

figure 8. Adaptive protection in microgrids. Comm Hub: communications hub.

Instead of protecting every feeder section, subsystems can be protected. An island can be subdivided into multiple sub-areas, each of which can be treated as a zone for differential protection. This will significantly reduce the expense, although with decreased selectivity. Most of these issues may also be relevant to islands at the subtransmission level, but the topology and existing transmission infrastructure may better absorb the cost of upgrades compared to distribution systems. For example, such systems would have breakers at both ends of lines already available. This is also true for urban distribution feeders that operate in a ring-main configuration.

Since the local protection options are either limited or unreliable, communication-enabled protection options can be considered. Since microgrids would typically have a communication infrastructure and a controller, this approach could be feasible. For example, the actual differential function can be integrated with the microgrid controller to reduce the expense of relays. However, protection-related data must get priority in the communication network. This option may adversely affect the speed of differential protection, but due to low fault currents, this may not pose a problem.

Adaptive protection using directional overcurrent relays exploiting the communication platform of microgrids can modify protective actions according to system condition changes. Since the fault profile is different in grid-connected and islanded modes, the focus in this approach is to provide two different sets of settings for each relay to work under these modes. Adaptive protection using only directional overcurrent relays can work as long as the fault contribution from inverters is large enough to be distinguishable from other events like peak load and in-rush current, but the adaptive protection can also change the protection scheme of the microgrid when in islanded mode to other schemes, such as distance protection, voltage-restrained overcurrent, or communication-assisted approaches, that will work with low fault currents.

Conclusions

System protection has been developed and refined through decades of experience to protect system components and maintain stability against the fault response of synchronous generators, which is typified by dangerously high magnitudes of fault currents and rapidly changing angles. Fault currents from IBRs are in the range of overloads, and they do not have rotating parts, which obviates the issue with angular instability. However, legacy protection systems designed to tackle traditional fault responses become unreliable in the presence of IBRs. Inside inverter-based microgrids, more complications arise due to the change in the very topology that is assumed to underpin its protection.

This article provides insights into the stable operation and fault response of inverters at up to 100% penetration of IBRs in a distribution system microgrid, both for grid-connected

and islanded modes of operation, including mode transition. Many traditional protection schemes have drawbacks, but communication-based options, including differential protection and adaptive protection, can emerge as potential solutions to protect such microgrids.

Acknowledgments

We thank Jacob Mueller and Nicholas S. Gurule of Sandia National Laboratories for their contributions to the figures used in this article.

For Further Reading

J. Rodriguez, S. Bernet, P. K. Steimer, and I. E. Lizama, "A survey on neutral-point-clamped inverters," *IEEE Trans. Ind. Electron.*, vol. 57, no. 7, pp. 2219–2230, 2010. doi: 10.1109/TIE.2009.2032430.

S. S. Venkata, M. J. Reno, W. Bower, S. Manson, J. Reilly, and G. W. Sey Jr., "Microgrid protection: Advancing the state of the art," Sandia National Lab., Albuquerque, NM, SAND2019-3167, 2019.

A. Haddadi, M. Zhao, I. Kocar, U. Karaagac, K. W. Chan, and E. Farantatos, "Impact of inverter-based resources on negative sequence quantities-based protection elements," *IEEE Trans. Power Del.*, vol. 36, no. 1, 2020. doi: 10.1109/TPWRD.2020.2978075.

T. Kauffmann et al., "Short-circuit model for type-IV wind turbine generators with decoupled sequence control," *IEEE Trans. Power Del.*, vol. 34, no. 5, pp. 1998–2007, 2019. doi: 10.1109/TPWRD.2019.2908686.

L. Che, M. E. Khodayar, and M. Shahidehpour, "Adaptive protection system for microgrids: Protection practices of a functional microgrid system," *IEEE Electr. Mag.*, vol. 2, no. 1, pp. 66–80, 2014. doi: 10.1109/MELE.2013.2297031.

M. Ropp and M. J. Reno, "Influence of inverter-based resources on microgrid protection: Part 2," *IEEE Power & Energy Mag.*, vol. 19, no. 3, pp. 47–57, 2021.

S. Brahma, "Protection of distribution system islands fed by inverter-interfaced sources," in *Proc. IEEE PES PowerTech 2019*, Milan, Italy.

T. Patel, P. Gadde, S. Brahma, J. Hernandez-Alvidrez, and M. Reno, "Real-time microgrid test bed for protection and resiliency studies," in *Proc. North American Power Symp. 2020*, Tempe, AZ, April 2021.

Biographies

Matthew J. Reno is with Sandia National Laboratories, Albuquerque, New Mexico, 87185, USA.

Sukumar Brahma is with Clemson University, Clemson, South Carolina, 29634, USA.

Ali Bidram is with the University of New Mexico, Albuquerque, New Mexico, 87131, USA.

Michael E. Ropp is with Sandia National Laboratories, Albuquerque, New Mexico, 87185, USA.

