

DGP/DGPL rodless drive units

FESTO

High force
in a confined space



Info 114 →→



DGP/DGPL – Each version a highlight of its own

Powerful

The precision guide and the high load rating on the DGP/L family ensure exceptional operational reliability, even under aggressive ambient conditions.

Choice of variants

Because no application is the same as any other, you can choose from a diverse range of diameters between 8 and 80 mm on the DGP/L. The range extends from dirt protected versions (-GA) through to life-long lubricated versions and versions with force inverter or longer slide.

Space saving

The advantages of the DGP/L come fully to the fore particularly in applications where space is at a premium. All drive units require only minimum fitting space regardless of size.

Flexibility

The DGP/L provides you with maximum flexibility – thanks to variable air connections, attachment and mounting options, sensor systems for optional integration, variable end-position cushioning systems and external clamping units.

Universal

Our electromechanical and pneumatic positioning axes of type DGE and DGPIIL incorporate the same design as the DGP/L. Here as well, benefit from the time-proven mechanical system, the precise guidance and the high flexibility.

DGP/L – Simply take the lead.

Limitless diversity

The concept of the DGP/L rodless drive unit enables you to forge ahead leaving behind previous concepts of size and overall performance. This diverse range brings together type diversity, high dynamic response, high load rating and minimum space requirement in a single unit.

The DGP/L is an excellent performer both as an individual component and in a multi-axis networked system – a first-rate strategy against second-class automation.

You can now opt for the broadest range of rodless drive units on the market.

New on the DGP/L

Of course, our developers and designers are constantly further-improving the DGP/L so as to be able to offer you an appropriate solution to any problem. New features in the range include the protected version and force inverter.



Protected DGP/L – the dirt-proof version -GA.

Is it necessary to invert your drive unit? The “force inverter” -AK will take care of this. The drive unit is fitted with the slide pointing downwards protected against dirt particles and the force can still be applied upward with the aid of the force inverter.



DGP/L – Preprogrammed productivity.

Linear drives DGP/DGPL

Selection aid

FESTO

General information

- Compact, fitting length relative to stroke
- Highly adaptable, thanks to wide choice of mounting and attachment options
- Adjustable end-position cushioning systems
- Can be combined with the modular system for handling and assembly technology
- Maintenance-free (for up to 5000 km with a recirculating ball bearing guide)
- Wide choice of variants:
 - Clamping unit
 - Extended slide
 - Air connections on both sides
 - Electronic cushioning with SoftStop SPC11

Basic design DGP

- Piston \varnothing 18 ... 80 mm
- Stroke lengths 10 ... 3000 mm
- As a drive for external guides
- For small loads



With plain-bearing guide DGPL-GF-GK/-GV

- Piston \varnothing 18 ... 80 mm
- Stroke lengths 10 ... 3000 mm
- Minimal backlash
- For medium loads and low torques



With recirculating ball bearing guide DGPL-KF-GK/-GV

- Piston \varnothing 18 ... 80 mm
- Stroke lengths 10 ... 3000 mm
- Backlash-free
- Precision, rigid guide
- For high loads and torques



Protected version DGPL-GA

- Piston \varnothing 18 ... 40 mm
- Stroke lengths 10 ... 2000 mm
- Guide and slide are fitted with a cover to protect against the ingress of particles from above and from the side
- Backlash-free
- Precision, rigid guide
- For high loads and torques



With heavy-duty guide DGPL-HD

- Piston \varnothing 18 ... 40 mm
- Stroke lengths 10 ... 2160 mm
- Backlash-free
- Maximum precision

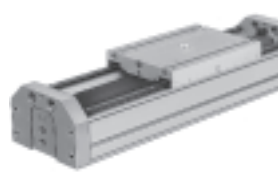

Linear drives DGP/DGPL

Selection aid

Guide characteristics

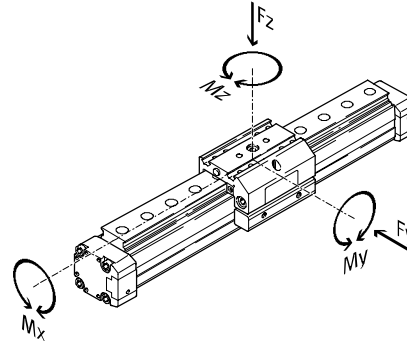

Version	Piston \varnothing [mm]	Stroke ¹⁾ [mm]	Theoretical force at 6 bar [N]	Forces and torques					→ Page
				Fy [N]	Fz [N]	Mx [Nm]	My [Nm]	Mz [Nm]	
Basic version without guide DGP									
	18	10 ... 1800	153	-	120	1	22	2	8
	25	10 ... 3000	295		330	2	40	6	
	32	10 ... 3000	483		480	4	80	10	
	40	10 ... 3000	754		800	8	120	16	
	50	10 ... 3000	1178		1200	14	240	30	
	63	10 ... 3000	1870		1600	16	240	48	
	80	10 ... 3000	3016		5000	32	750	140	
With plain-bearing guide DGPL-GF									
	18	10 ... 1800	153	340	340	2.2	18	18	26
	25	10 ... 3000	295	430	430	5.4	25	25	
	32	10 ... 3000	483	430	430	8.5	30	30	
	40	10 ... 3000	754	1010	1010	23	58	58	
	50	10 ... 3000	1178	1010	1010	32	83	83	
	63	10 ... 3000	1870	2000	2000	74	235	235	
	80	10 ... 3000	3016	2000	2000	100	230	230	
With recirculating ball bearing guide DGPL-KF									
	18	10 ... 1800	153	930	930	7	45	45	26
	25	10 ... 3000	295	3080	3080	45	170	170	
	32	10 ... 3000	483	3080	3080	63	250	250	
	40	10 ... 3000	754	7300	7300	170	660	660	
	50	10 ... 3000	1178	7300	7300	240	920	920	
	63	10 ... 3000	1870	14050	14050	580	1820	1820	
	80	10 ... 3000	3016	14050	14050	745	1545	1545	
With heavy-duty guide DGPL-HD									
	HD18	10 ... 1710	153	1820	1820	70	115	112	48
	HD25	10 ... 2160	295	5400	5600	260	415	400	
	HD40	10 ... 2110	754	5400	5600	375	560	540	

1) With effective strokes of over 2000 mm the installation of the drive unit must be with the sealing strip facing down; longer strokes available on request.

- - Note
Piston \varnothing 8 and 12
Linear drives DGC
→ Info 119

Linear drives DGP/DGPL

Key features

FESTO

The technology in detail

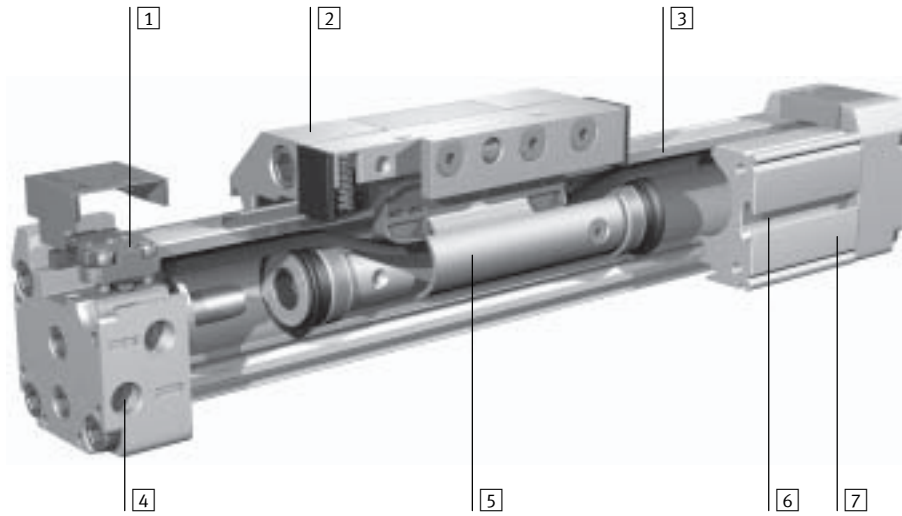

- 1 Adjustable end-position cushioning, alternatively:
 - Shock absorber
 - SoftStop SPC11
- 2 Slide is permanently attached to the driver

- 3 Cover strip protects the drive against the ingress of dirt
- 4 Choice of supply port positions, options on three sides on the end cap

- 5 Piston
- 6 Mounting/sensor slot for integral proximity sensors, additional slot for slot nuts with piston \varnothing 32 and above
- 7 Stable profile

Linear drives DGP/DGPL

Key features

System product for handling and assembly technology

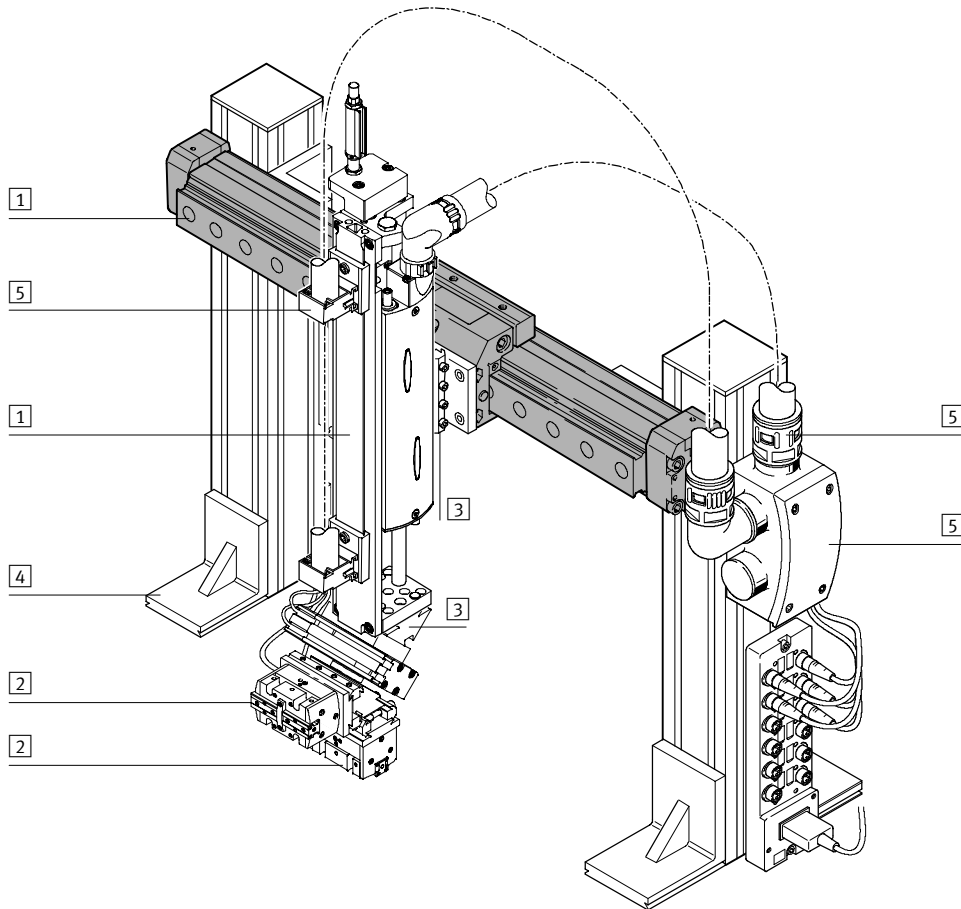

System components and accessories		
	Brief description	→ Page
1	Linear drives	Wide range of combination options within handling and assembly technology www.festo.com
2	Grippers	Wide range of combination options within handling and assembly technology www.festo.com
3	Adapters	For combining drives with drives and drives with grippers www.festo.com
4	Basic components	Profiles and profile connectors as well as profile/drive connectors www.festo.com
5	Installation components	For achieving a clear-cut, safe layout for electrical cables and tubing www.festo.com
-	Axes	Wide range of combination options within handling and assembly technology www.festo.com
-	Motors	Servo and stepper motors, with or without gearing www.festo.com

Linear drives DGP

Peripherals overview

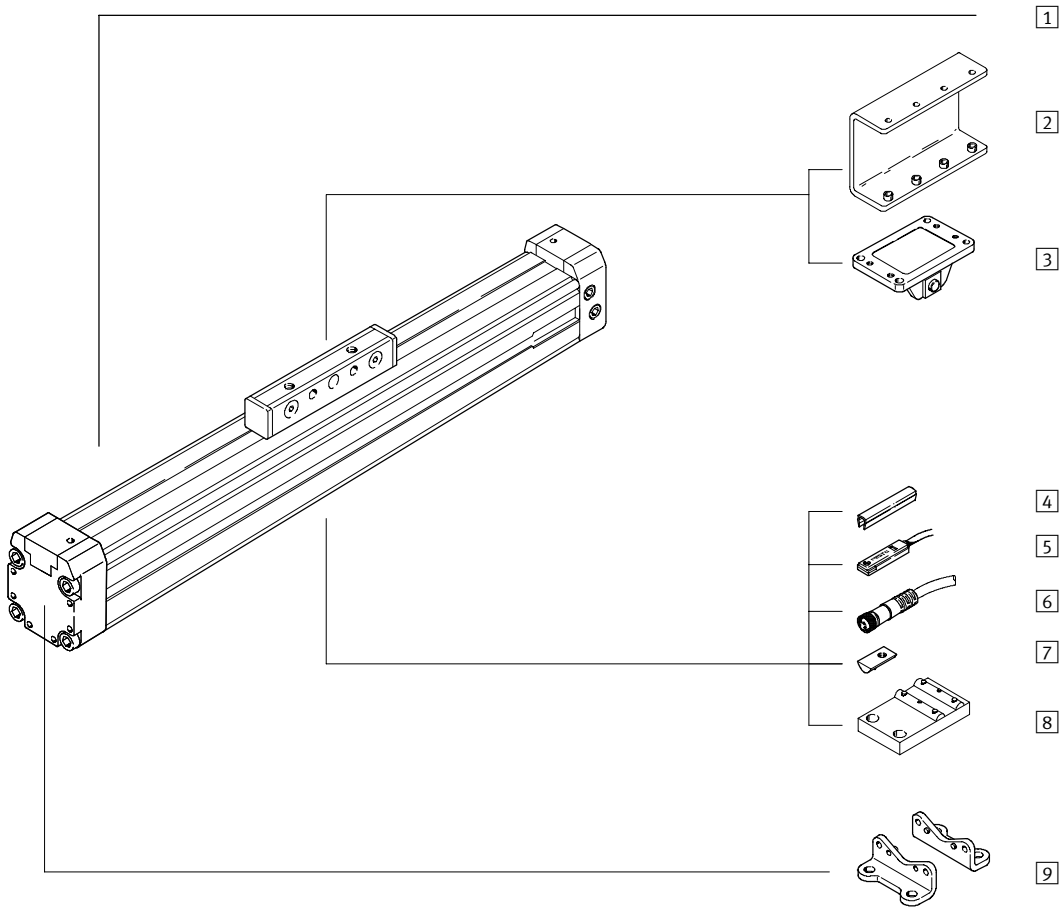

Linear drives DGP

Peripherals overview

Variants and accessories			
	Type	Brief description	→ Page
1	Linear drive DGP	Pneumatic linear drive with driver	10
2	Load inverter AK	The driver should be mounted pointing downwards with long strokes > 2 m or unfavourable environments. By using the load inverter it means that the load can be attached from above.	63
3	Moment compensator FK	For compensating misalignments when using external guides	64
4	Slot cover B/S	For protecting against dirt and securing proximity sensor cables	67
5	Proximity sensor G/H/I/J/N	For sensing the driver position	69
6	Plug socket with cable V	For proximity sensors	69
7	Slot nut for profile slot Y	For mounting attachments	67
8	Central support M	For mounting the axis, particularly with long strokes	61
9	Foot mounting F	For mounting the axis	60

Linear drives DGP

Type code

		DGP	-	25	-	500	-	PPV	-	A	-	B	-	KV	-	GK	-	D2	-	CT	
Type																					
DGP	Linear drive																				
Piston \varnothing																					
Stroke [mm]																					
Cushioning																					
PPV	Adjustable end-position cushioning																				
Position sensing																					
A	Via magnet																				
Generation																					
B	B series																				
Clamping unit																					
KV	Front																				
KH	Rear																				
Basic design																					
GK	Standard driver																				
GV	Extended driver																				
Supply port/accessories																					
D2	Supply port at both ends																				
FK	Moment compensator																				
AK	Load inverter																				
Special materials																					
CT	Free of Copper and PTFE																				

Linear drives DGP

Type code

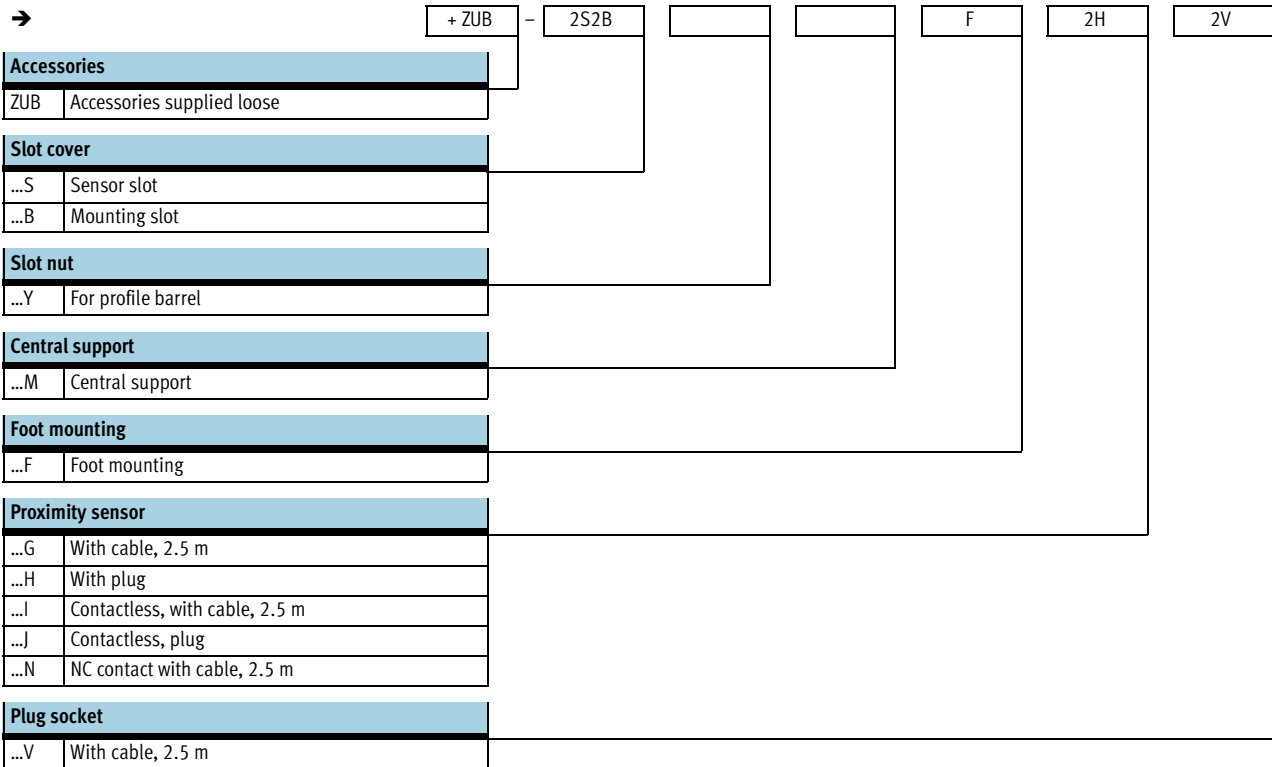



Linear drives DGP

Technical data

FESTO

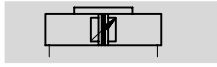
Function



 Spare parts service

Wearing parts kits
→ 22

-  - Diameter
18 ... 80 mm

-  - Stroke length
1 ... 3000 mm



General technical data							
Piston Ø	18	25	32	40	50	63	80
Constructional design	Pneumatic linear drive with driver						
Protection against torsion/guide	Slotted profile barrel						
Mode of operation	Double-acting						
Driver principle	Positive-locking (slot)						
Mounting position	Any						
Pneumatic connection	M5	G ¹ / ₈		G ¹ / ₄		G ³ / ₈	G ¹ / ₂
Stroke length [mm]	10 ... 1800		10 ... 3000 ¹⁾				
Cushioning (PPV)	Adjustable at both ends						
Cushioning length [mm]	16	18	20	30			83
Position sensing	Via magnet						

1) With effective strokes of over 2000 mm the installation of the drive unit must be with the sealing strip facing down; longer strokes available on request.

Operating and environmental conditions							
Piston Ø	18	25	32	40	50	63	80
Operating medium	Filtered compressed air, lubricated or unlubricated						
Operating pressure [bar]	2 ... 8			1.5 ... 8			
Ambient temperature ¹⁾ [°C]	-10 ... +60						

1) Note operating range of proximity sensors.

Forces [N] and impact energy [Nm]							
Piston Ø	18	25	32	40	50	63	80
Theoretical force at 6 bar	153	295	483	754	1178	1870	3016
Impact energy	→ 15						

Weights [kg]							
Piston Ø	18	25	32	40	50	63	80
Basic weight with 0 mm stroke	0.46	0.84	1.55	2.65	5.88	9.1	17.3
Additional weight per 10 mm stroke	0.016	0.036	0.041	0.057	0.111	0.148	0.158
Moving load	0.08	0.18	0.32	0.55	1.55	1.76	5.0

Linear drives DGP

Technical data

Materials

Sectional view

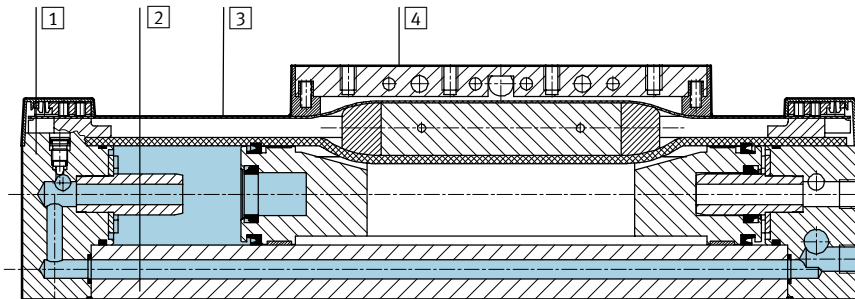

Axis	18	25	32	40	50	63	80
1 End cap	Anodised aluminium						
2 Profile	Anodised aluminium						
3 Cover strip	Corrosion resistant steel						Polyurethane
4 Driver	Anodised aluminium						
- Seals	Nitrile rubber, polyurethane						

Linear drives DGP

Technical data

Characteristic load values

The indicated forces and torques refer to the centre line of the internal diameter of the profile barrel. They must not be exceeded in the dynamic range. Special attention must be paid to the cushioning phase.

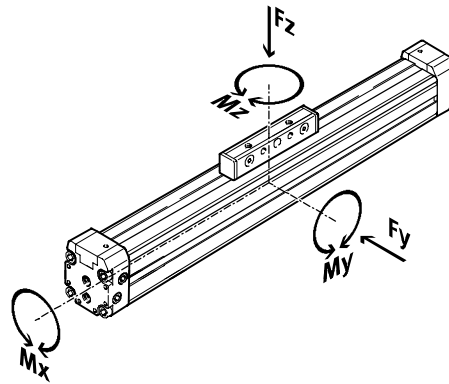

If the drive is subjected to more than two of the indicated forces and torques simultaneously, the following equations must be satisfied in addition to the indicated maximum loads:

$$0.4 \times \frac{Fz}{Fz_{max.}} + \frac{Mx}{Mx_{max.}} + \frac{My}{My_{max.}} + 0.2 \times \frac{Mz}{Mz_{max.}} \leq 1$$

$$\frac{Fz}{Fz_{max.}} \leq 1 \quad \frac{Mz}{Mz_{max.}} \leq 1$$

Permissible forces and torques								
Piston Ø		18	25	32	40	50	63	80
Standard driver GK								
Fy _{max.}	[N]	-						
Fz _{max.}	[N]	120	330	480	800	1200	1600	5000
Mx _{max.}	[Nm]	0.5	1	2	4	7	8	32
My _{max.}	[Nm]	11	20	40	60	120	120	750
Mz _{max.}	[Nm]	1	3	5	8	15	24	140
Extended driver GV								
Fy _{max.}	[N]	-						
Fz _{max.}	[N]	120	330	480	800	1200	-	-
Mx _{max.}	[Nm]	1	2	4	8	14	16	-
My _{max.}	[Nm]	22	40	80	120	240	240	-
Mz _{max.}	[Nm]	2	6	10	16	30	48	-



ProDrive selection and ordering aid
www.festo.com/en/engineering

Linear drives DGP

Technical data

Operating range of the integrated end-position cushioning PPV

Maximum permissible speed v as a function of the moving load m

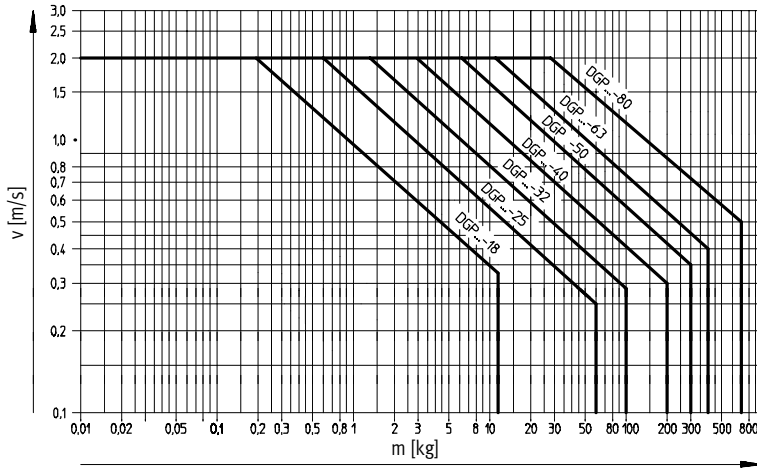

Note
The data applies to a horizontal mounting position, applied load on top.
 m = Applied load + moving load (→ 12)
The graph opposite refers to r_{max} .

Pneumatic linear drives

The end-position cushioning must be adjusted to ensure jerk-free operation. If the operating conditions are outside the permissible range, the load to be moved must be externally

cushioned using suitable equipment (shock absorbers, stops, etc), preferably at the centre of gravity of the mass.

with driver DGP

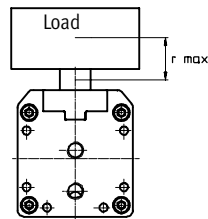

$r_{max} = 20$ mm
for piston $\varnothing 18$ mm

$r_{max} = 50$ mm
for piston $\varnothing 25 \dots 80$ mm
(data for greater load distances on request)

Maximum permissible support span l as a function of the force F

The axis may need to be supported with central supports MUP in order to restrict deflection with long stroke

lengths. The following diagrams serve to determine the maximum permissible support span l as a

function of the force F acting upon the axis.

Force on the surface of the slide

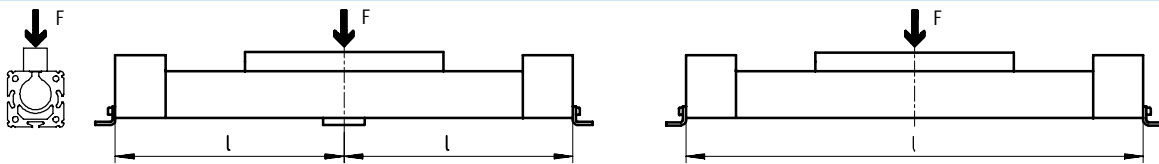

Piston $\varnothing 18 \dots 40$

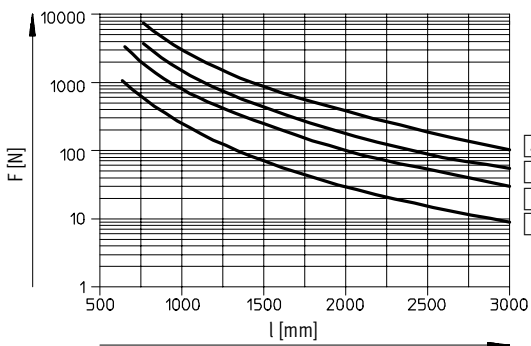

- 1 DGP...-18
- 2 DGP...-25
- 3 DGP...-32
- 4 DGP...-40

Piston $\varnothing 50 \dots 80$

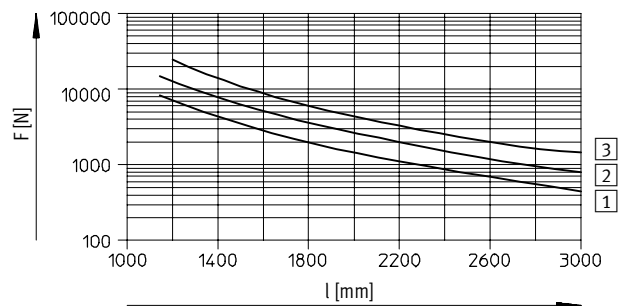

- 1 DGP...-50
- 2 DGP...-63
- 3 DGP...-80

Linear drives DGP

Technical data

Dimensions

Download CAD data → www.festo.com/en/engineering

Standard driver GK

Piston $\varnothing 18$

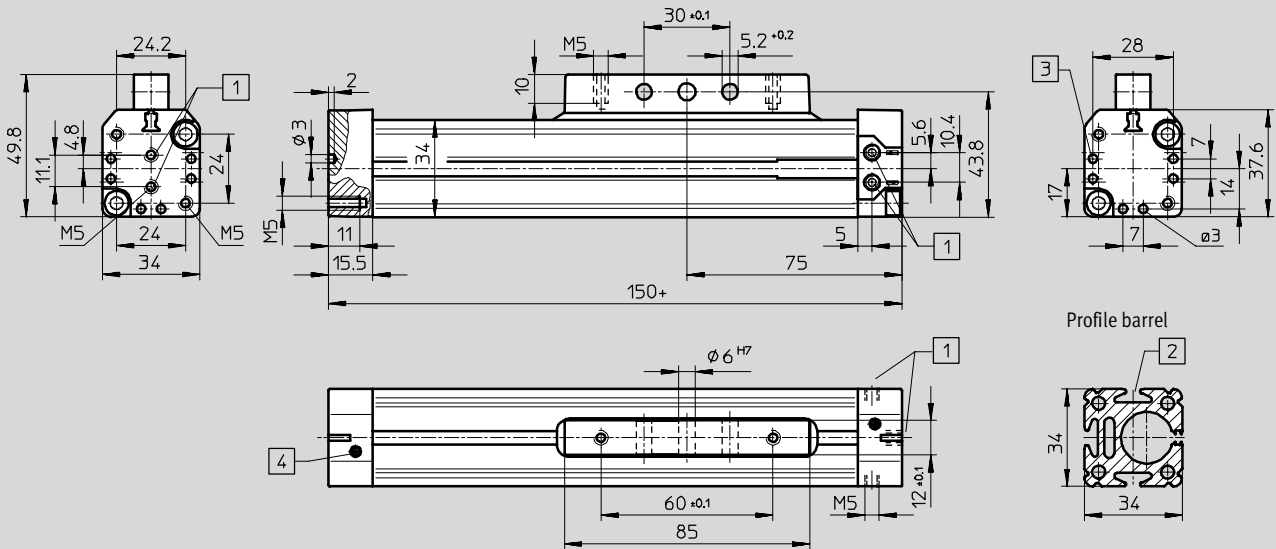

1 Supply ports at one end, option of three sides of an end cap (D2 variant: supply port at both ends, option of three sides per end cap)

2 Sensor slot for proximity sensor

3 Mounting hole for foot mounting HP

4 Regulating screw for adjustable end-position cushioning

+ = plus stroke length

Extended driver GV

Piston $\varnothing 18$

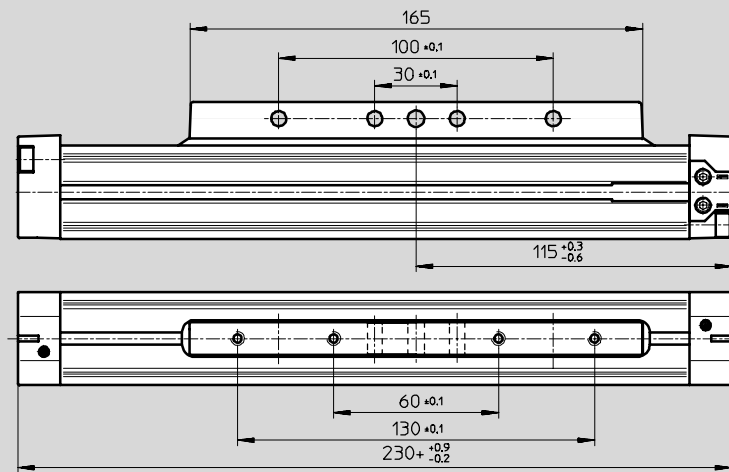

+ = plus stroke length

Linear drives DGP

Technical data

Dimensions

Download CAD data → www.festo.com/en/engineering

Standard driver GK

Piston $\varnothing 25$

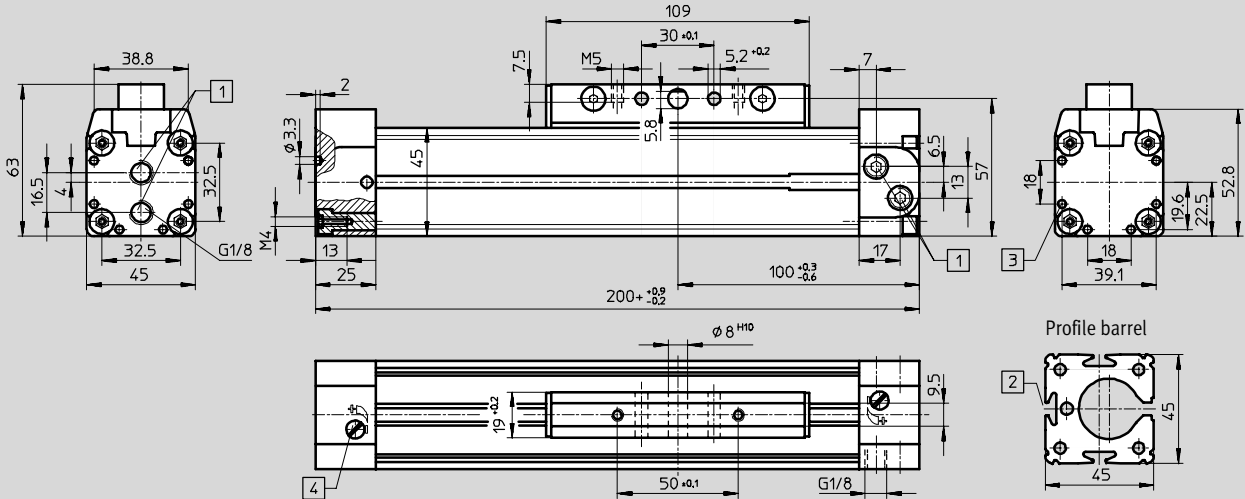

- 1 Supply ports at one end, option of three sides of an end cap (D2 variant: supply port at both ends, option of three sides per end cap)
- 2 Sensor slot for proximity sensor
- 3 Mounting hole for foot mounting HP
- 4 Regulating screw for adjustable end-position cushioning

+ = plus stroke length

Extended driver GV

Piston $\varnothing 25$

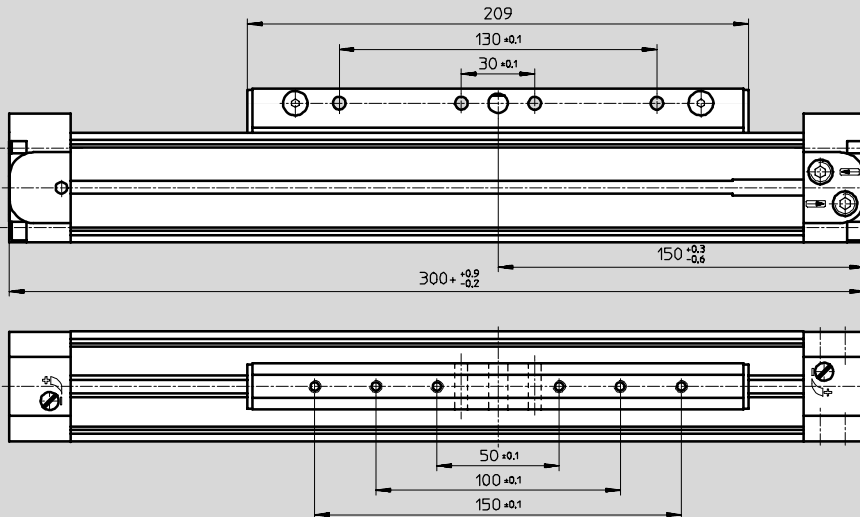

+ = plus stroke length

Linear drives DGP

Technical data

Dimensions

Download CAD data → www.festo.com/en/engineering

Standard driver GK

Piston Ø 80

Piston Ø 32 ... 63

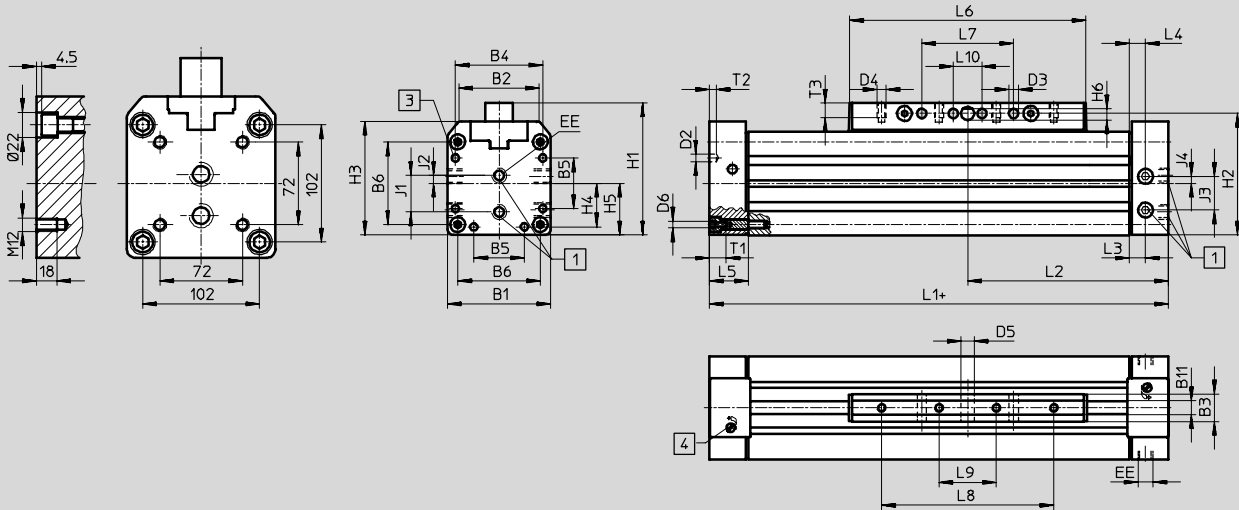

1 Supply ports at one end, option of three sides of an end cap (D2 variant: supply port at both ends, option of three sides per end cap)

3 Mounting hole for foot mounting HP

4 Regulating screw for adjustable end-position cushioning

+ = plus stroke length

Extended driver GV

Piston Ø 32 ... 63

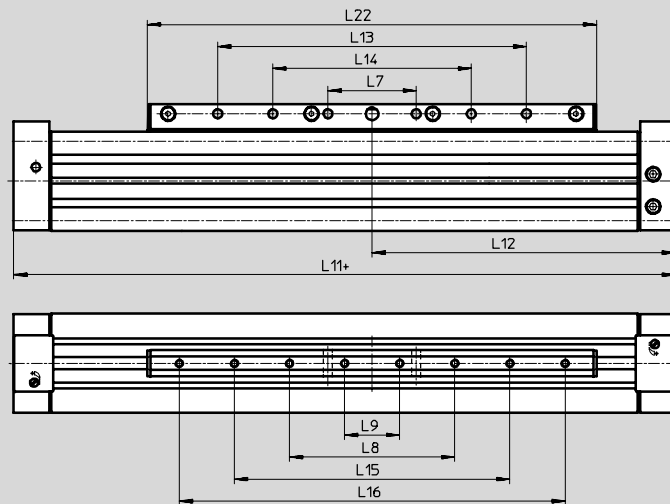

+ = plus stroke length

Linear drives DGP

Technical data

Profile barrel

Piston \varnothing 32

Piston \varnothing 40

Piston \varnothing 50

Piston \varnothing 63

Piston \varnothing 80

2 Sensor slot for proximity sensor

6 Sensor slot for slot nut NST

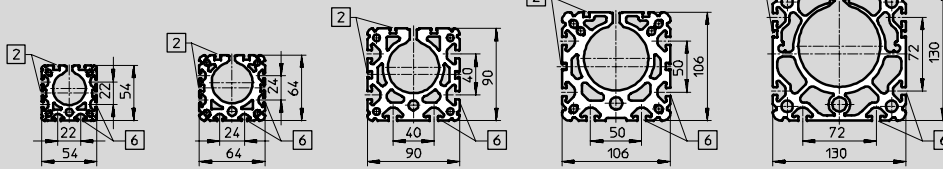

\varnothing [mm]	B1	B2	B3 ± 0.2	B4	B5	B6	B11	D2 \varnothing	D3 \varnothing ± 0.2	D4	D5 \varnothing H10	D6	EE	H1	H2
32	54	35.8	19	46	21	40	9.5	4.3	5.2	M5	8	M5	G $\frac{1}{8}$	72	66
40	64	45.7	21	53	28	49			6.5	M6	10		G $\frac{1}{4}$	86	78
50	90	69.2	24	76	44	72	12	6.3	8.5	M8	12	M6	G $\frac{1}{4}$	115	106
63	106	84.8		89		83						M8	G $\frac{3}{8}$	131	122
80	130	102.5	36	-	-	-	-	-	12.2	M12	20	-	G $\frac{1}{2}$	174	158

\varnothing [mm]	H3	H4	H5	H6	J1	J2	J3	J4	L1 $+0.9/-0.2$	L2 $+0.3/-0.6$	L3	L4	L5	L6
32	62	23	27	5.8	19	4.2	14	4.7	250	125	17	8.5	31	135
40	71.8	26.5	32	7.7	22	5	21	9.1	300	150	11.5	11.5		171
50	99	36	45	9.7	31.8	6.8	29.3	6	350	175	14	14	34	206
63	115	44.5	53		36	8	31	14	400	200				234
80	140.5	51	65	-			33.3	3.6	520	260	19	19	45	334

\varnothing [mm]	L7	L8	L9	L10 ± 0.15	L11 $+0.9/-0.2$	L12 $+0.3/-0.6$	L13 ± 0.1	L14 ± 0.1	L15 ± 0.1	L16 ± 0.1	L22	T1	T2	T3
32	50 ± 0.1	100 ± 0.1	30 ± 0.1	-	380	190	180	-	160	230	265	13.2	3	7.5
40	70 ± 0.1	130 ± 0.1	40 ± 0.1		470	235	160	250	220	-	341		4	10.5
50	80 ± 0.1	150 ± 0.1	50 ± 0.1		550	275	280	-	250	350	406	15.2	6	12.5
63	110 ± 0.1	190 ± 0.1	70 ± 0.1		650	325	380		310	430	484	21.2		
80	180 ± 0.15	230 ± 0.15	115 ± 0.15	60	-	-	-		-	-	-	-	-	19

Linear drives DGP

Technical data – Clamping unit

Clamping unit DGPL-...-KV/KH

The clamping unit is clamped in the unpressurised state.

General technical data					
Piston Ø		18	25	32	40
Constructional design	Spring actuated clamping profile				
Stroke	[mm]	10 ... 1800	10 ... 3000		

Operating and environmental conditions					
Piston Ø		18	25	32	40
Operating pressure	[bar]	4 ... 8			
Grade of filtration	[µm]	40			
Connection		G $\frac{1}{8}$			
Ambient temperature ¹⁾	[°C]	-10 ... +60			

1) Note for proximity sensors

Clamping unit weights [kg]					
Piston Ø		18	25	32	40
Basic weight with 0 mm stroke		0.388	0.649	0.985	1.446
Additional weight per 10 mm stroke		0.018	0.026	0.034	0.041
Moving load with 0 mm stroke		0.061	0.120	0.153	0.213

Materials

Sectional view

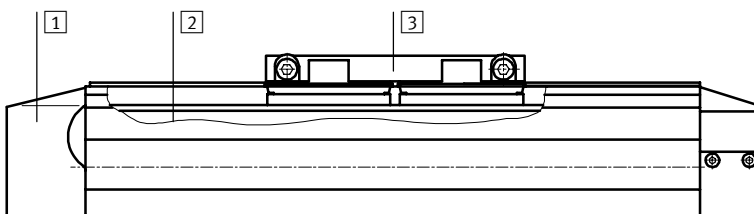

Clamping unit		
1	Housing	Anodised aluminium
2	Clamping profile	Anodised aluminium
3	Driver	Anodised aluminium
-	Cover	Acrylic butadiene styrene
-	Seals	Polyurethane

Linear drives DGP

Technical data – Clamping unit

Clamping unit DGP...-K...

Holding force F_H of the clamping unit dependent on the stroke l

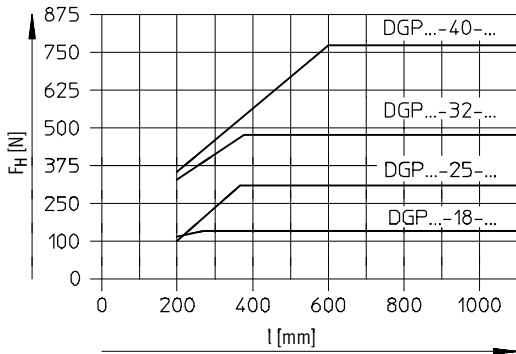

- - Note
 Environmental conditions:
 Clamping surfaces oil, grease and dirt-free

Dimensions

Download CAD data → www.festo.com/en/engineering

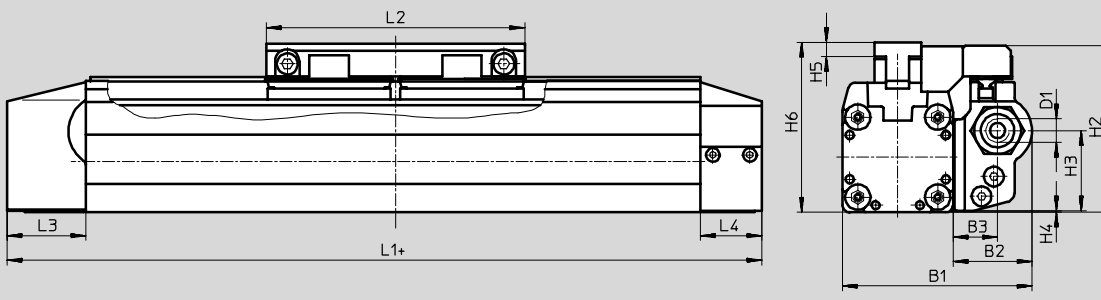

- - Note
 Clamping units DGP...-K... have a supply port at one end.

for \varnothing	B1	B2	B3	B4	D1	H1	H2	H3	H4	H5	H6	L1	L2	L3	L4	L5	L6
[mm]	max.	max.	max.	max.						± 0.1							
18	56.8	31.2	17.2	-	G1/8	-	56.7	28.5	0.5	8.2	58	176	85	32	25	16.5	9.5
25	72	33.3	19.3				67.8	32.7	0.6	5.9	69.2	207	105			7	-
32	83	32.7	17.7				76.8	41	1	5.9	78.2	251	131		31	1	
40	96.4	37.1	23.1				90	54.6	1.7	5.4	91.7	301	167				

Linear drives DGP

Ordering data

Ordering data – Standard stroke		
Piston Ø	Part No.	Type
25	526 645	DGP-25-250-PPV-A-B
	526 646	DGP-25-400-PPV-A-B
	526 647	DGP-25-500-PPV-A-B
	526 648	DGP-25-1000-PPV-A-B
32	526 653	DGP-32-250-PPV-A-B
	526 654	DGP-32-400-PPV-A-B
	526 655	DGP-32-500-PPV-A-B
	526 656	DGP-32-1000-PPV-A-B
40	526 661	DGP-40-250-PPV-A-B
	526 662	DGP-40-400-PPV-A-B
	526 663	DGP-40-500-PPV-A-B
	526 664	DGP-40-1000-PPV-A-B

Ordering data – Variable stroke		
Piston Ø	Part No.	Type
18	158 971	DGP-...-PPV-A-B
25	161 780	DGP-...-PPV-A-B
32	161 781	DGP-...-PPV-A-B
40	161 782	DGP-...-PPV-A-B
50	161 783	DGP-...-PPV-A-B
63	161 784	DGP-...-PPV-A-B
80	161 785	DGP-...-PPV-A-B

Ordering data – Wearing parts kits		
Piston Ø	Part No.	Type
18	384 266	DGP-18-...-PPV-A
25	123 563	DGP-25-...-PPV-A
32	123 564	DGP-32-...-PPV-A
40	123 565	DGP-40-...-PPV-A
50	123 566	DGP-50-...-PPV-A
63	123 567	DGP-63-...-PPV-A
80	123 568	DGP-80-...-PPV-A

 Note
 Piston Ø 8 and 12
 Linear drives DGC
[➔ Info 119](#)

 Core Range

Linear drives DGP

Ordering data – Modular products

Order code

Mandatory data

GK	Standard slide	AK	Load inverter
GV	Extended slide	KV	Clamping unit at front
D2	Supply port at both ends	KH	Clamping unit at rear
FK	Moment compensator	CT	Free of copper and PTFE

Standard slide GK
Extended slide GV

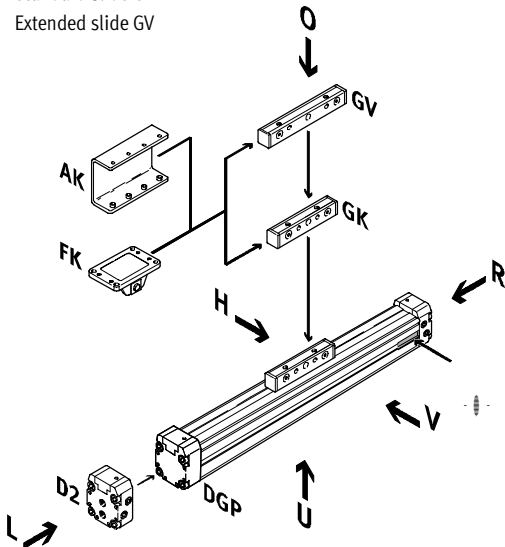

- - Note

The insertion point for the proximity sensor is located on the right-hand side of the pneumatic linear drive DGP.

O top
U underneath
R right
L left
V front
H rear

Clamping units KH/KV

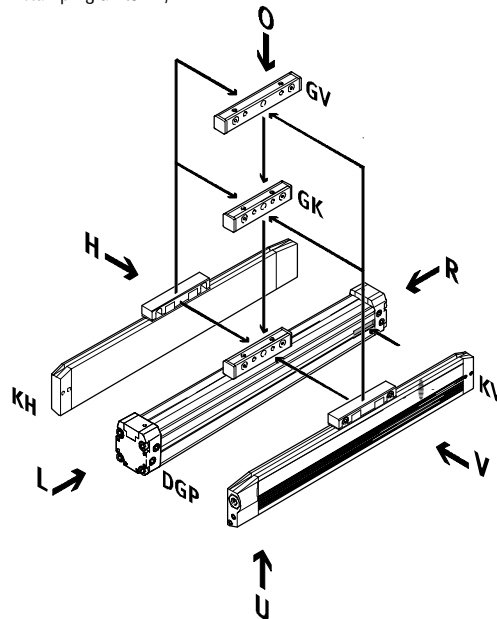

Options

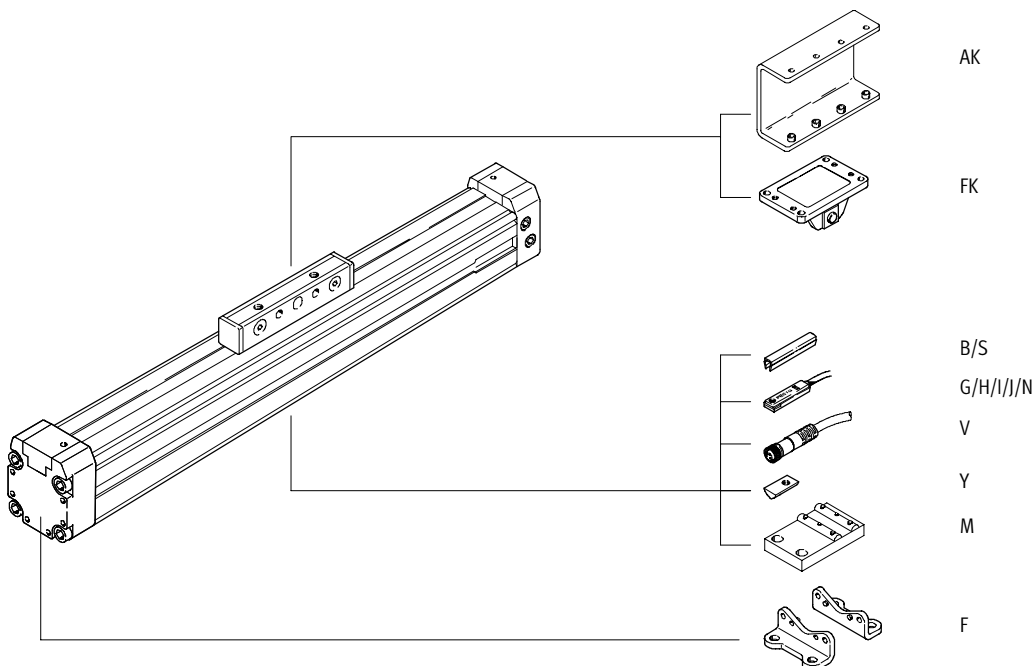

Linear drives DGP

Ordering data – Modular products



M Mandatory data							O Options →			
Module No.	Drive function	Size	Stroke	Cushioning	Position sensing	Generation	Clamping unit	Basic design	Supply port/driver	Special materials
175 131	DGP	18	10 ... 300	PPV	A	B	KV	GK	D2	CT
175 132		25	0				KH	GV	FK	
175 133		32						AK		
175 134		40								
175 135		50								
175 136		63								
175 137		80								
175 138										
175 139										
Ordering example										
175 134	DGP	- 25	- 500	- PPV	- A	- B	- KH	- GV	- D2	-

Ordering table												
Size	18	25	32	40	50	63	80	Conditions	Code	Enter code		
M Module No.	175 133	175 134	175 135	175 136	175 137	175 138	175 139					
Drive function	Pneumatic linear drive								DGP	DGP		
Size	18	25	32	40	50	63	80		-...			
Stroke [mm]	10 ... 1800		10 ... 3000									-...
Cushioning	Pneumatic cushioning adjustable at both ends									-PPV		
Position sensing	Via magnet									-A	-A	
Generation	B series									-B	-B	
O Clamping unit	Front				-	-	-	[1]	-KV			
	Rear				-	-	-	[1]	-KH			
Basic design	Standard piston/slide								-GK			
	Extended piston/slide							-		-GV		
Supply port	At both ends									-D2		
Driver	Moment compensator, assembled for DGP (FKP)							[1]	-FK			
	Load inverter							-		-AK		
Special materials	Free of copper and PTFE									-CT		

[1] KV, KH Not with special material CT.

Transfer order code

	DGP	-		-		-	A	-	B	-		-		-	
--	-----	---	--	---	--	---	---	---	---	---	--	---	--	---	--

Linear drives DGP

Ordering data – Modular products

Options

Accessories	Slot cover	Slot nut	Central support	Foot mounting	Proximity sensor	Plug socket
ZUB	...S ...B	...Y	...M	...F	...G ...H ...I ...J ...N	...V
- ZUB	- 10S			F	2H	2V

Ordering table

Size	18	25	32	40	50	63	80	Condi- tions	Code	Enter code	
↓ Accessories	Supplied separately								:ZUB-	:ZUB-	
Slot cover, 2 pcs., 0.5 m	Sensor slot 1 ... 10									...S	
	Mounting slot		1 ... 10							...B	
Slot nut	Profile barrel		1 ... 10							...Y	
Central support	1 ... 10									...M	
Foot mounting	1 ... 10									...F	
Proximity sensor, magnetic	with cable, 2.5 m		1 ... 10 (SME-8-K-LED-24)							...G	
	with plug		1 ... 10 (SME-8-S-LED-24)							...H	
Proximity sensor, magnetic, contactless	with cable, 2.5 m		1 ... 10 (SMT-8-PS-K-LED-24)							...I	
	with plug		1 ... 10 (SMT-8-PS-S-LED-24)							...J	
Proximity sensor, magnetic	NC contact with cable, 2.5 m		1 ... 10 (SME-8-O-K-LED-24)							...N	
Plug socket	with cable, 2.5 m		1 ... 10 (SIM-M8-3GD-2,5-PU)							...V	

Transfer order code

- : **ZUB** -

Linear drives DGPL, with guide

Peripherals overview

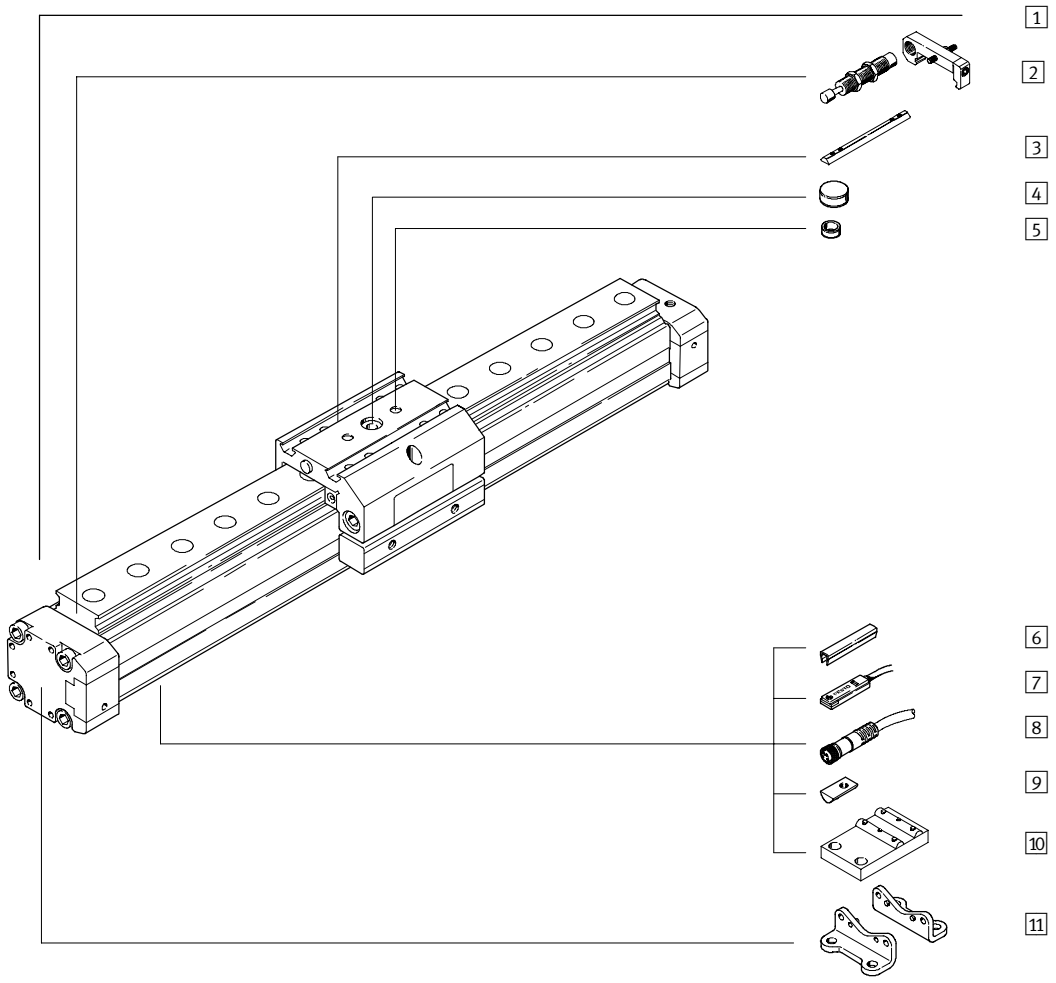

Linear drives DGPL, with guide

Peripherals overview

Variants and accessories					
Type	Brief description	GF/KF	GA	→ Page	
1 Linear axis DGPL	Pneumatic linear drive with slide	■	■	28	
2 Shock absorber kit C	For slowing higher speeds to a stop	■	-	65	
2 Shock absorber kit E	For slowing higher speeds to a stop	-	■	66	
3 Slot nut for slide X	For mounting loads and attachments on the slide	■	■	67	
4 Central mounting Q	For centring loads and attachments on the slide	■	■	67	
5 Centring pins/sleeves Z	For centring loads and attachments on the slide	■	■	67	
6 Slot cover B/S	For protecting against dirt and securing proximity sensor cables	■	■	67	
7 Proximity sensor G/H/I/J/N	For sensing the slide position	■	■	69	
8 Plug socket with cable V	For proximity sensors	■	■	69	
9 Slot nut for profile barrel Y	For mounting attachments	■	■	67	
10 Central support M	For mounting the axis	■	■	61	
11 Foot mounting F	For mounting the axis	■	■	60	

Linear drives DGPL, with guide

Type code

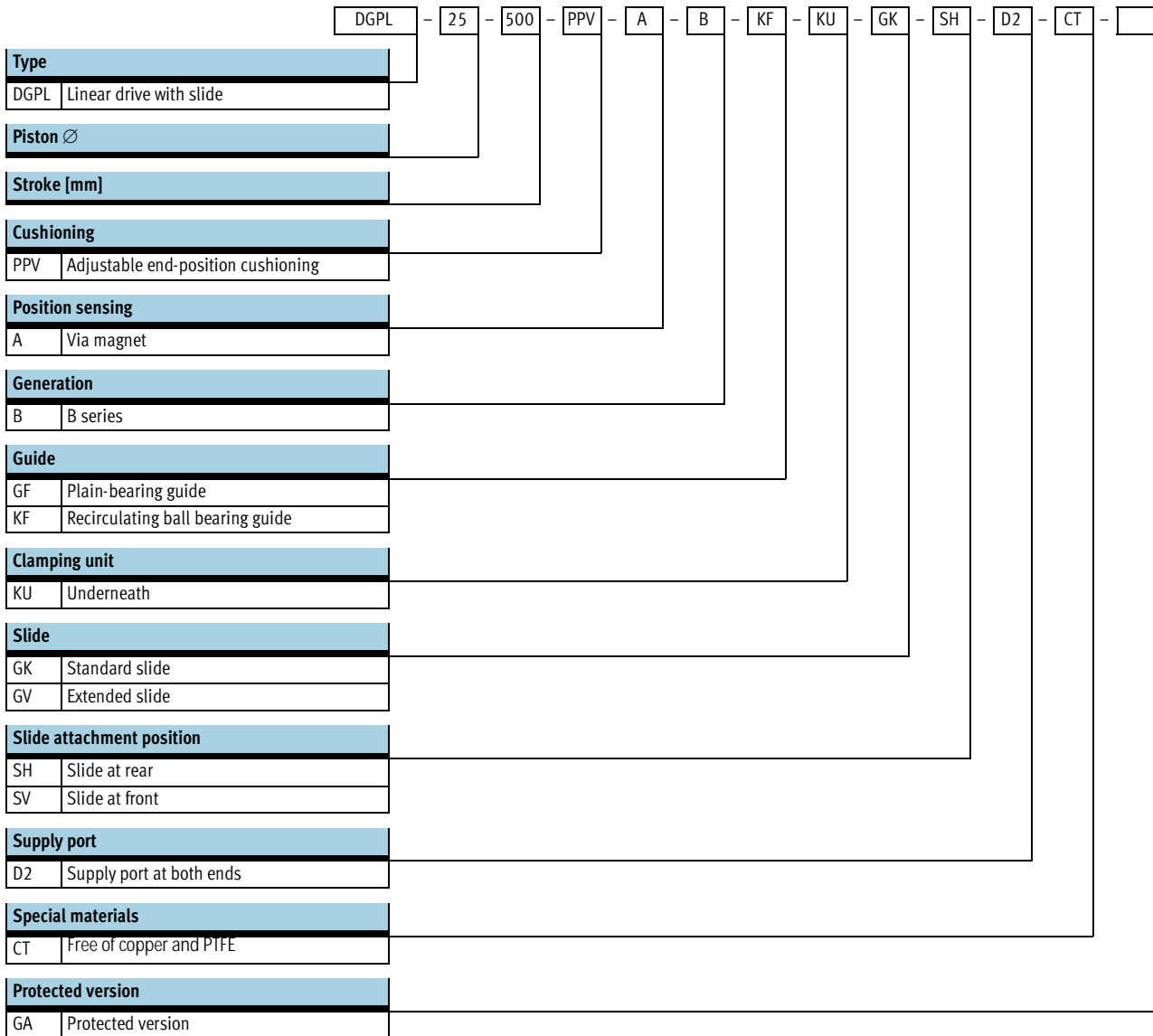

Linear drives DGPL, with guide

Type code

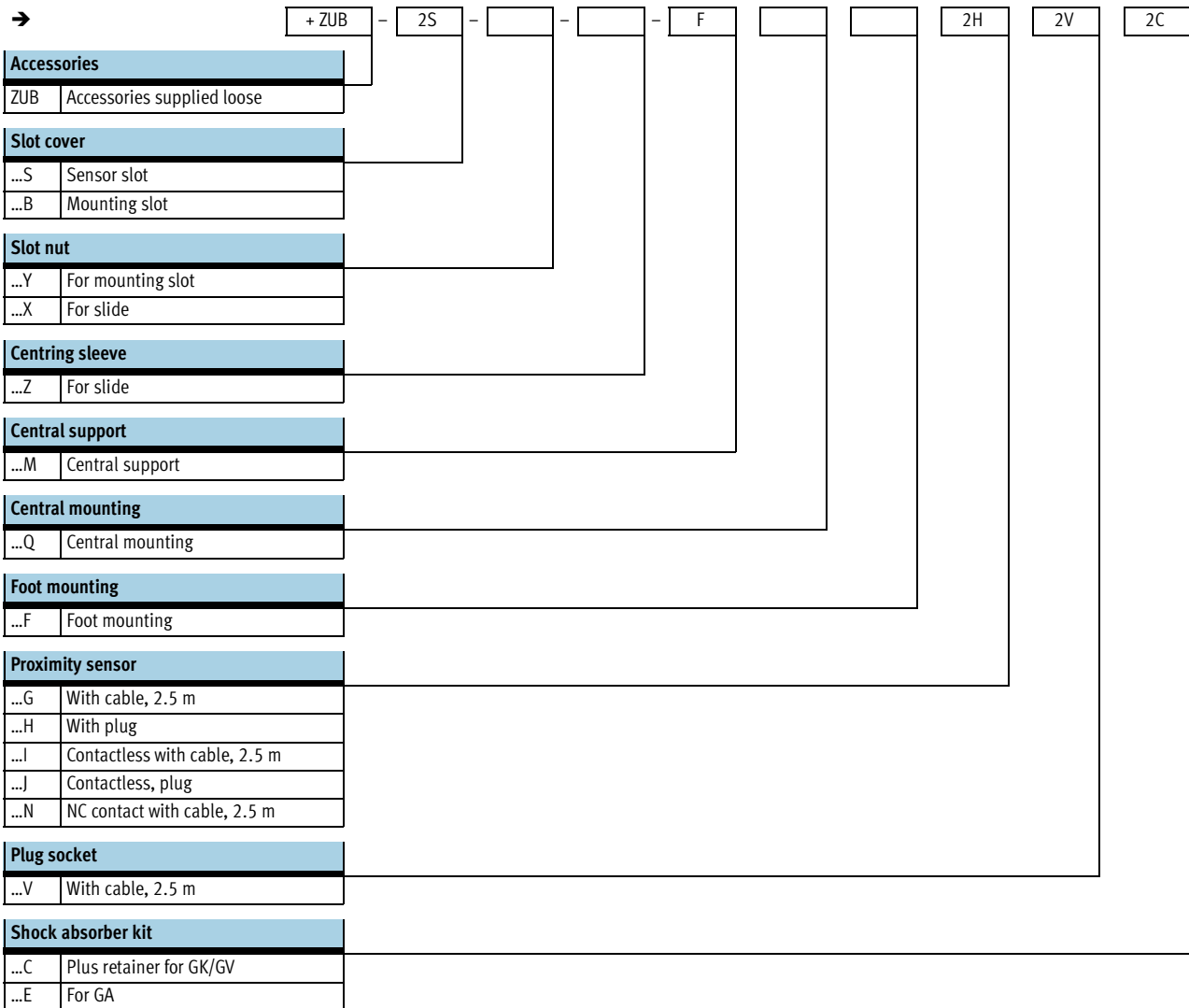

Linear drives DGPL, with guide

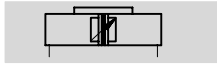

Technical data

Function



 Spare parts service

Wearing parts kits
→ 44

-  - Diameter
18 ... 80 mm
-  - Stroke length
1 ... 3000 mm

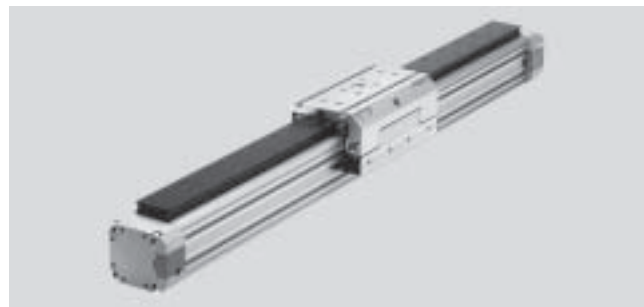

General technical data							
Piston Ø	18	25	32	40	50	63	80
Constructional design	Pneumatic linear drive with slide						
Protection against torsion/guide	Guide rail with slide and plain-bearing guide GF or recirculating ball bearing guide KF						
Mode of operation	Double-acting						
Driver principle	Positive-locking (slot)						
Mounting position	Any						
Pneumatic connection	M5	G $\frac{1}{8}$		G $\frac{1}{4}$		G $\frac{3}{8}$	G $\frac{1}{2}$
Stroke length [mm]	10 ... 1800	10 ... 3000 ¹⁾					
Cushioning	Adjustable at both ends Self-adjusting at both ends						
Cushioning length (PPV) [mm]	16	18	20	30			83
Position sensing	Via magnet						
Max. speed	GF [m/s]	1					
	KF [m/s]	3					
	GA [m/s]	-	3				-

1) With effective strokes of over 2000 mm the installation of the drive unit must be with the sealing strip facing down; longer strokes available on request.

Operating and environmental conditions							
Piston Ø	18	25	32	40	50	63	80
Operating medium	Filtered compressed air, lubricated or unlubricated						
Operating pressure [bar]	2 ... 8			1.5 ... 8			
Ambient temperature ¹⁾ [°C]	-10 ... +60						
Corrosion resistance for variant GF	CRC ²⁾	2					

1) Note operating range of proximity sensors.

2) Corrosion resistance class 2 according to Festo standard 940 070

Components requiring moderate corrosion resistance. Externally visible parts with primarily decorative surface requirements which are in direct contact with a surrounding industrial atmosphere or media such as cooling or lubricating agents.

Forces [N] and impact energy [Nm]							
Piston Ø	18	25	32	40	50	63	80
Theoretical force at 6 bar	153	295	483	754	1178	1870	3016
Impact energy	→ 36						

Linear drives DGPL, with guide

Technical data

Weights [kg]		18	25	32	40	50	63	80
Piston Ø								
Basic weight with 0 mm stroke	GF	0.75	1.37	2.39	3.89	8.6	13.54	25.4
	KF	0.83	1.52	2.72	4.48	9.6	15.37	28.7
	GA	–	1.69			–	–	–
Additional weight per 10 mm stroke	GF	0.022	0.042	0.051	0.072	0.132	0.181	0.162
	KF	0.026	0.053	0.069	0.097	0.167	0.236	0.270
	GA	–	26			–	–	–
Moving load	GF	0.23	0.37	0.53	0.96	1.77	2.79	7.10
	KF	0.29	0.43	0.58	1.15	1.96	3.22	7.50
	GA	–	0.91			–	–	–

Materials

Sectional view

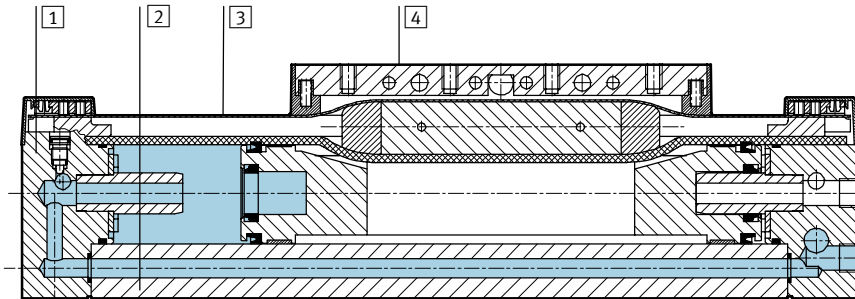

Axis		18	25	32	40	50	63	80
1	End cap	Anodised aluminium						
2	Profile	Anodised aluminium						
3	Cover strip	Corrosion resistant steel						Polyurethane
4	Driver	Anodised aluminium						
–	Slide	Anodised aluminium						
–	Guide rail	GF	Anodised aluminium					
		KF	Steel	Corrosion resistant steel				
–	Seals	Nitrile rubber, polyurethane						

Linear drives DGPL, with guide

Technical data

Characteristic load values for drive with plain-bearing guide GF

The indicated forces and torques refer to the centre of the guide rail. They must not be exceeded in the dynamic range. Special attention must be paid to the cushioning phase.

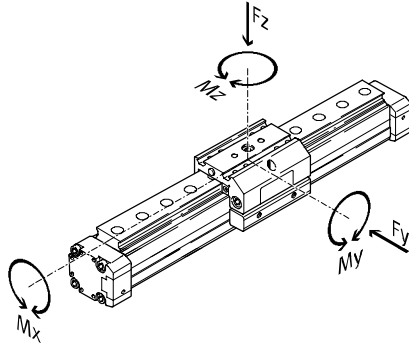

If the drive is subjected to more than two of the indicated forces and torques simultaneously, the following equations must be satisfied in addition to the indicated maximum loads:

$$\frac{F_y}{F_{y_{max}}} + \frac{F_z}{F_{z_{max}}} + \frac{M_x}{M_{x_{max}}} + \frac{M_y}{M_{y_{max}}} + \frac{M_z}{M_{z_{max}}} \leq 1$$

 Note
All values for the GF version refer to a speed of 0.2 m/s.

Permissible forces and torques								
Piston Ø		18	25	32	40	50	63	80
Standard slide GK								
F _y _{max.}	[N]	340	430	430	1010	1010	2000	2000
F _z _{max.}	[N]	340	430	430	1010	1010	2000	2000
M _x _{max.}	[Nm]	2.2	5.4	8.5	23	32	74	100
M _y _{max.}	[Nm]	10	14	18	34	52	140	230
M _z _{max.}	[Nm]	10	14	18	34	52	140	230
Extended slide GV								
F _y _{max.}	[N]	330	400	395	930	870	1780	–
F _z _{max.}	[N]	330	400	395	930	870	1780	–
M _x _{max.}	[Nm]	2	5	8	21	28	66	–
M _y _{max.}	[Nm]	18	25	30	58	83	235	–
M _z _{max.}	[Nm]	18	25	30	58	83	235	–



ProDrive selection and ordering aid
www.festo.com/en/engineering

Linear drives DGPL, with guide

Technical data

Characteristic load values for axis with recirculating ball bearing guide KF or protected version GA

The indicated forces and torques refer to the centre of the guide rail. They must not be exceeded in the dynamic range. Special attention must be paid to the cushioning phase.

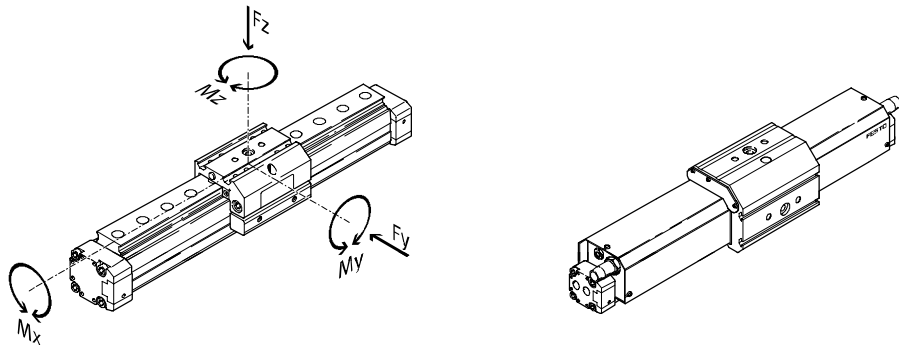

If the drive is subjected to more than two of the indicated forces and torques simultaneously, the following equations must be satisfied in addition to the indicated maximum loads:

$$\frac{F_y}{F_{y_{max}}} + \frac{F_z}{F_{z_{max}}} + \frac{M_x}{M_{x_{max}}} + \frac{M_y}{M_{y_{max}}} + \frac{M_z}{M_{z_{max}}} \leq 1$$

Permissible forces and torques								
Piston Ø		18	25	32	40	50	63	80
Standard slide GK								
F _y _{max.}	[N]	930	3080	3080	7300	7300	14050	14050
F _z _{max.}	[N]	930	3080	3080	7300	7300	14050	14050
M _x _{max.}	[Nm]	7	45	63	170	240	580	745
M _y _{max.}	[Nm]	23	85	127	330	460	910	1545
M _z _{max.}	[Nm]	23	85	127	330	460	910	1545
Extended slide GV								
F _y _{max.}	[N]	930	3080	3080	7300	7300	14050	–
F _z _{max.}	[N]	930	3080	3080	7300	7300	14050	–
M _x _{max.}	[Nm]	7	45	63	170	240	580	–
M _y _{max.}	[Nm]	45	170	250	660	920	1820	–
M _z _{max.}	[Nm]	45	170	250	660	920	1820	–

-  - Note
The values for standard slide GK and piston Ø 18 ... 40 apply to variant GA.

Linear drives DGPL, with guide

Technical data – Plain-bearing guide

Maximum permissible static and dynamic characteristic load values

Standard slide and plain-bearing guide DGPL-...-GF-GK-S

The pneumatic linear drive with plain-bearing guide DGPL-...-GF is designed for a maximum speed of 1 m/s. At higher speeds and vertical application, it is recommended that

pneumatic linear drives with recirculating ball bearing guide DGPL-...-KF are used as an alternative.

Maximum permissible speed v as a function of the force F

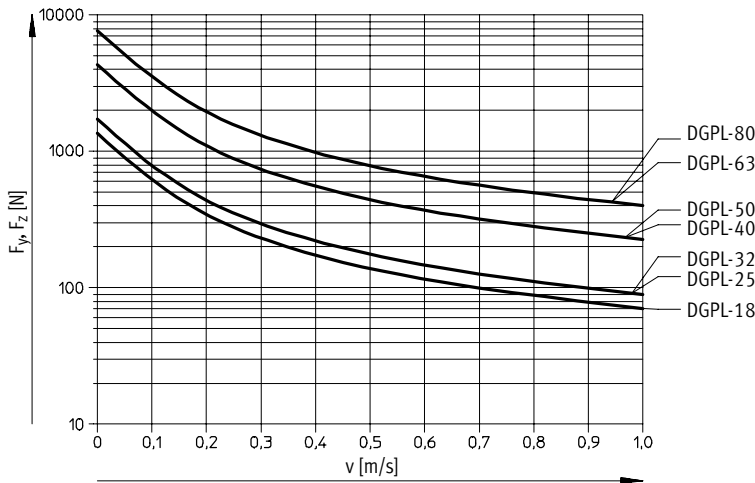

Maximum permissible speed v as a function of the permissible torque M

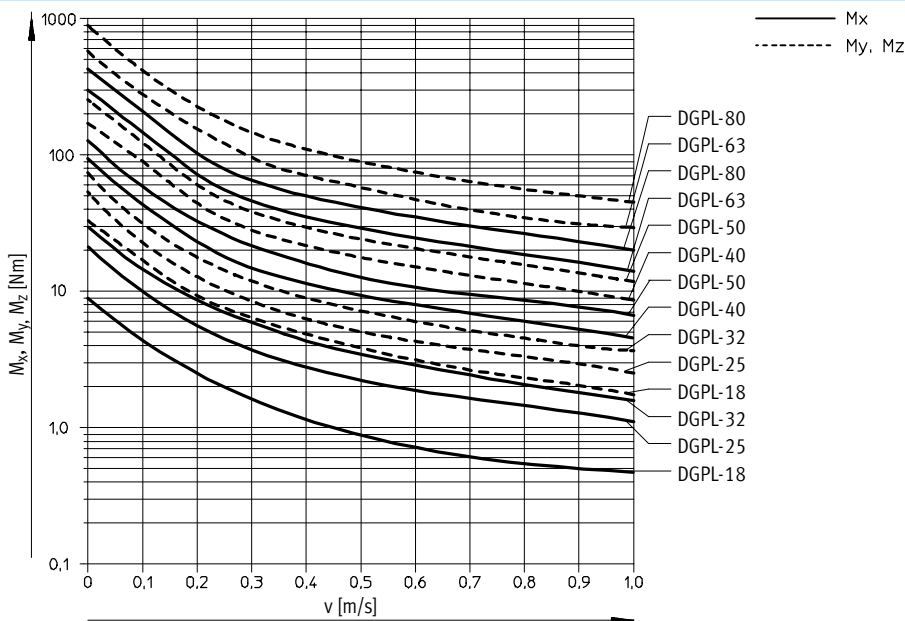

Linear drives DGPL, with guide

Technical data – Plain-bearing guide

Maximum permissible static and dynamic characteristic load values

Extended slide and plain-bearing guide DGPL-...-GF-GV-S

The pneumatic linear drive with plain-bearing guide DGPL-...-GF is designed for a maximum speed of 1 m/s. At higher speeds and vertical application, it is recommended that

pneumatic linear drives with recirculating ball bearing guide DGPL-...-KF are used as an alternative.

Maximum permissible speed in m/s as a function of the force F

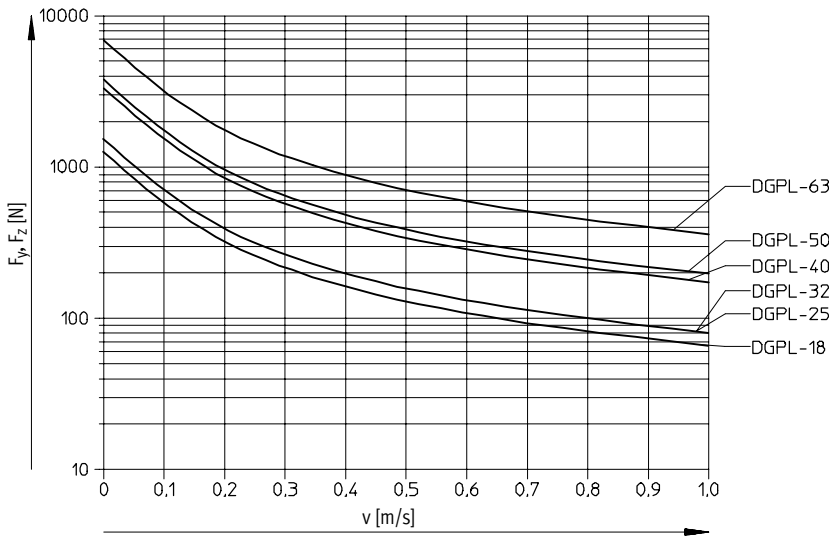

Maximum permissible speed in m/s as a function of the permissible torque M

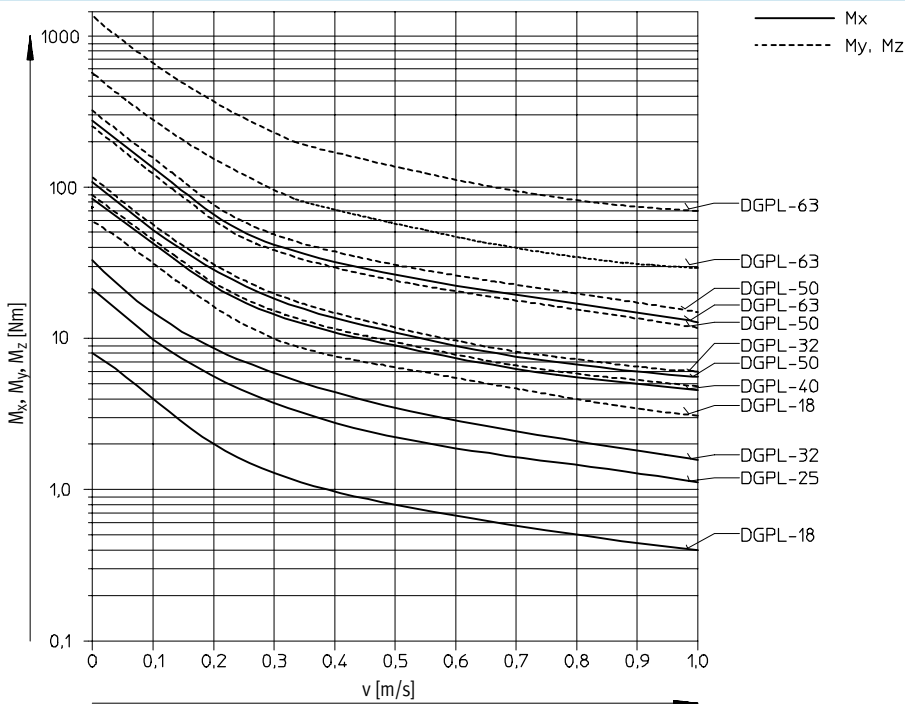

Linear drives DGPL, with guide

Technical data

Operating range of the integrated end-position cushioning PPV

Maximum permissible speed v as a function of the moving load M

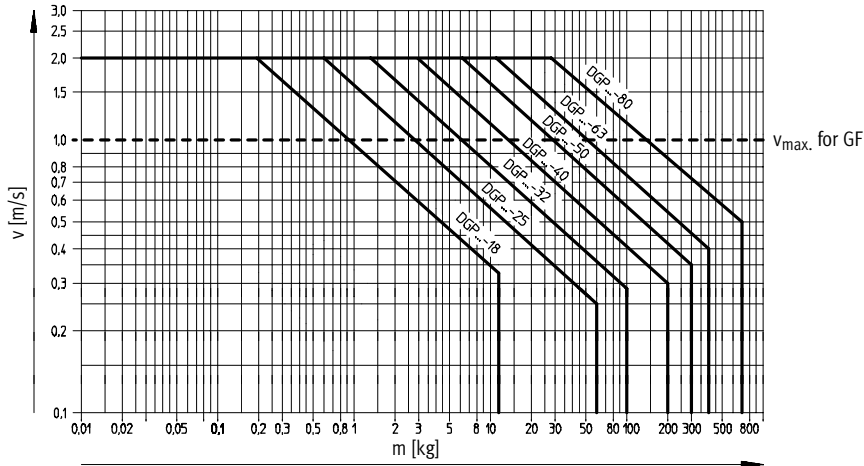

- - Note
 The data applies to a horizontal mounting position, applied load on top.

 m = Applied load + moving load
 → 31
 The graph opposite refers to r_{max} .

Pneumatic linear drives

The end-position cushioning must be adjusted to ensure jerk-free operation. If the operating conditions are outside the permissible range, the load to be moved must be externally cushioned using suitable equipment (shock absorbers, stops, etc), preferably at the centre of gravity of the mass.

with slide DGPL

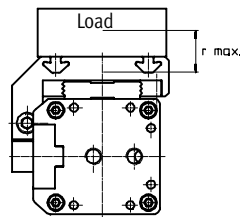

$r_{max.} = 20$ mm
 for piston $\varnothing 18$ mm

$r_{max.} = 50$ mm
 for piston $\varnothing 25 \dots 80$ mm
 (data for greater load distances on request)

- - Note
 Evenness of applied loads on pneumatic linear drives with slide DGPL: To avoid distortion or loosening of the guide elements, the bearing surface of the assembly must maintain a flatness of at least 0.03 mm.

Linear drives DGPL, with guide

Technical data

Maximum permissible support span l as a function of the force F

The axis may need to be supported with central supports MUP in order to restrict deflection with long stroke lengths. The following diagrams serve to determine the maximum permissible support span l as a function of the force F acting upon the axis.

Force on the surface of the slide

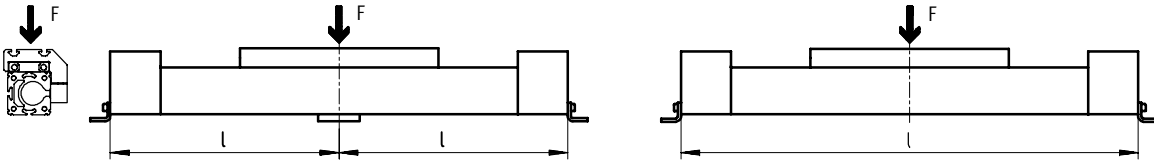

Piston $\varnothing 18 \dots 40$

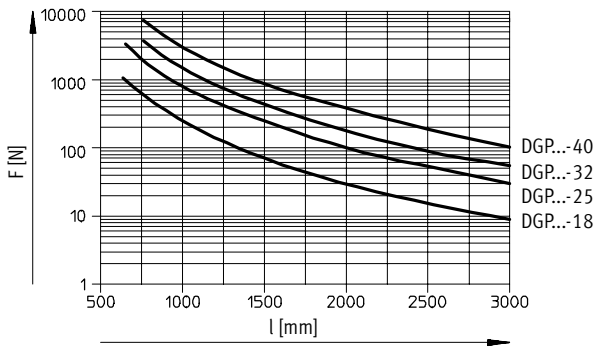

Piston $\varnothing 50 \dots 80$

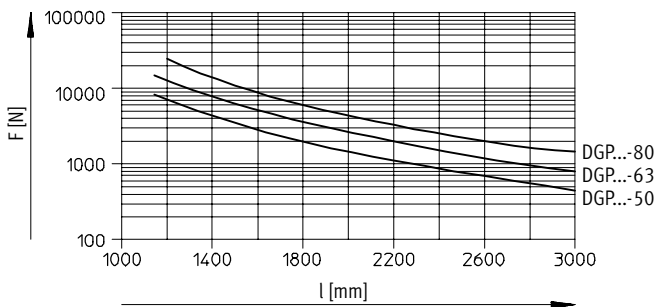

Linear drives DGPL, with guide

Technical data

Dimensions

Download CAD data → www.festo.com/en/engineering

Standard slide GK

Piston $\varnothing 18$

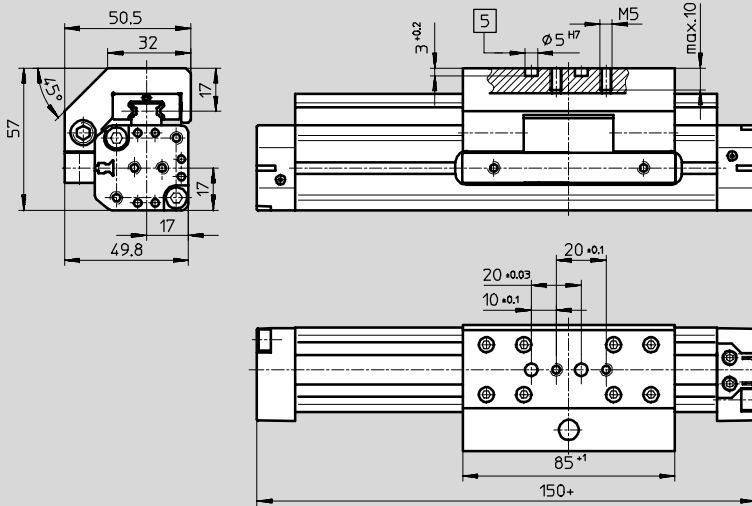

5 Holes for centring pin ZBS 5

+ = plus stroke length

Basic dimensions

→ 16

Extended slide GV

Piston $\varnothing 18$

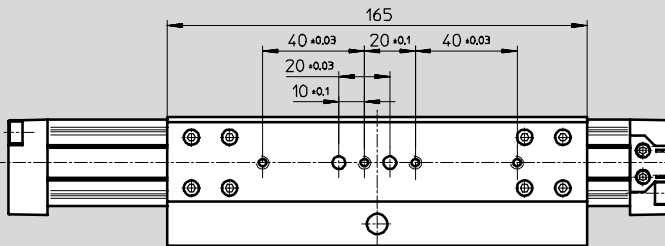

Protected version GA

Piston $\varnothing 18$

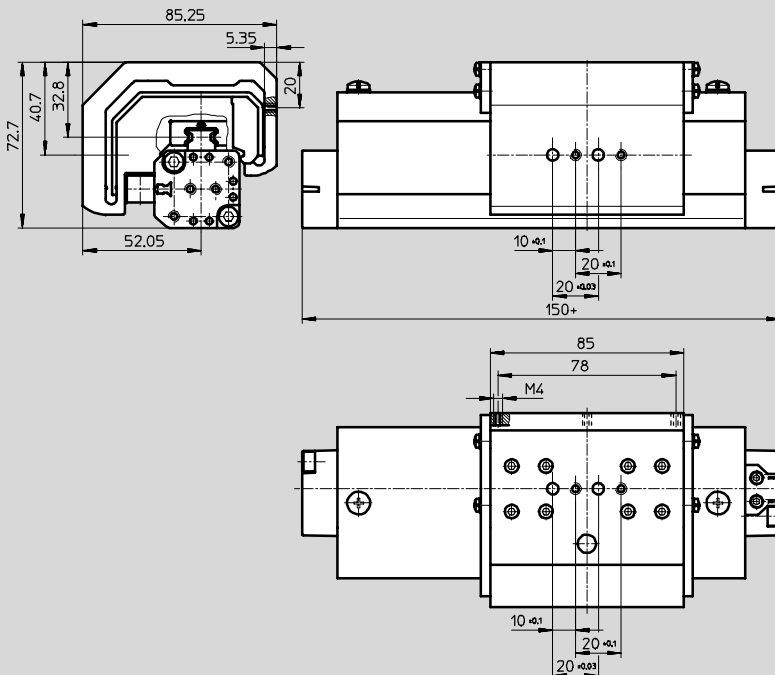

Linear drives DGPL, with guide

Technical data

Dimensions

Download CAD data → www.festo.com/en/engineering

Standard slide GK

Piston Ø 25

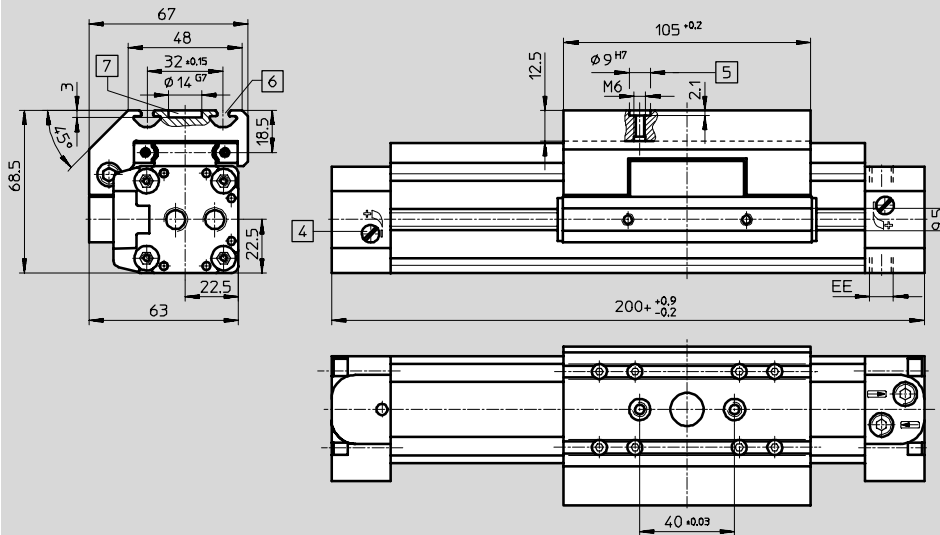

- 5 Hole for centring sleeve ZBH-9
- 6 Mounting slot for slot nut NSTL-25
- 7 Hole for central mounting SLZZ

+ = plus stroke length

Basic dimensions

→ 17

Extended slide GV

Piston Ø 25

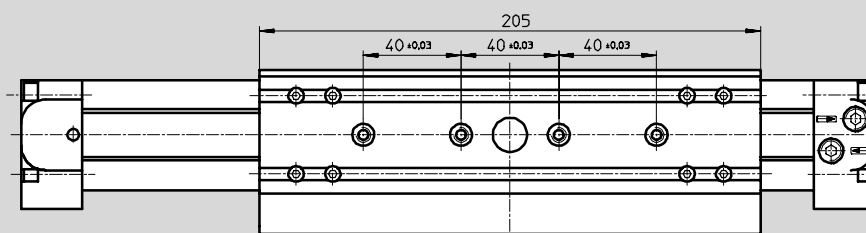

Protected version GA

Piston Ø 25 ... 40

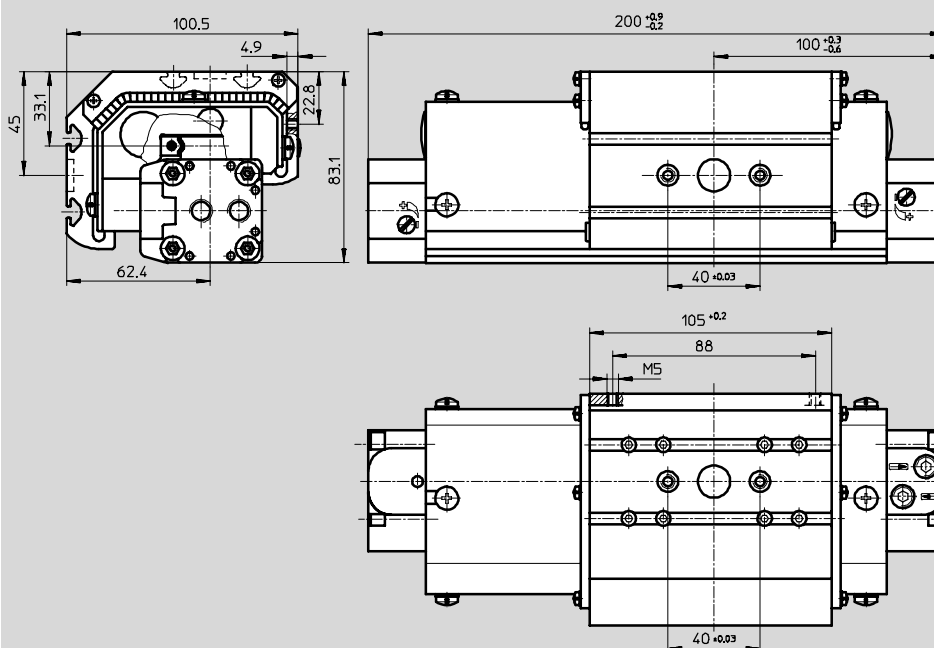

Linear drives DGPL, with guide

Technical data



Dimensions

Download CAD data → www.festo.com/en/engineering

Standard slide GK

Piston $\varnothing 32 \dots 80$

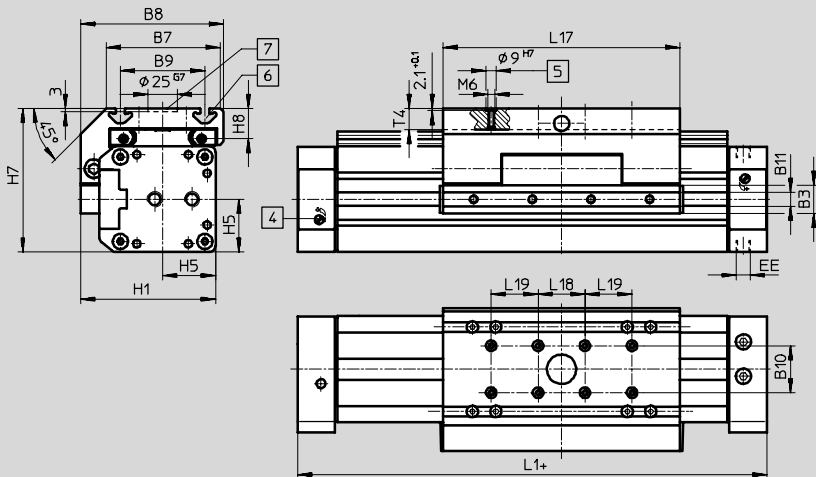

- 5 Hole for centring sleeve ZBH-9
- 6 Mounting slot for slot nut NSTL
- 7 Hole for central mounting SLZZ

+ = plus stroke length

Basic dimensions

→ 18

Extended slide GV

Piston $\varnothing 32 \dots 63$

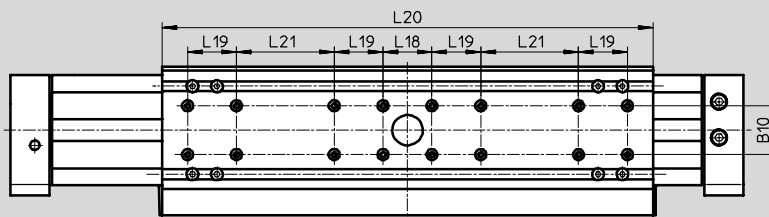

Protected version GA

Piston $\varnothing 32 \dots 40$

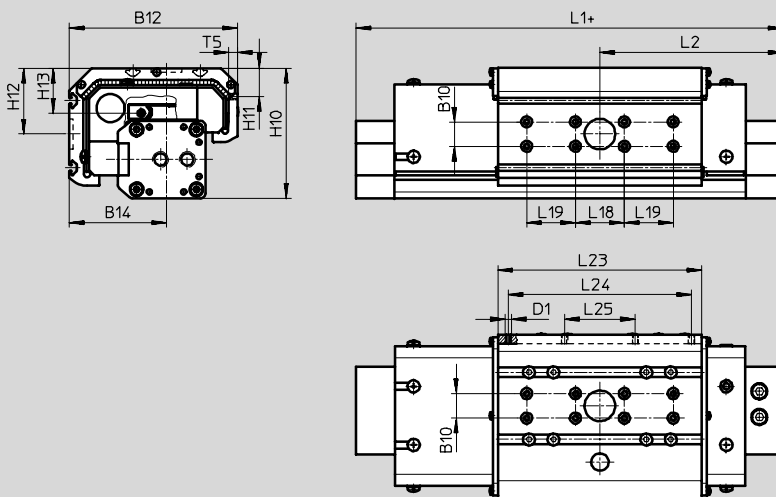

Linear drives DGPL, with guide

Technical data

∅ [mm]	B3 +0.2	B7	B8	B9	B10 ±0.03	B11	B12	B14	D1	EE
32	19	63	79	47 ±0.15	20	9.5	112.1	67.6	-	G $\frac{1}{8}$
40	21	78.5	96.5	55 ±0.2			137.6	79.6	M5	G $\frac{1}{4}$
50	24	97	122	72 ±0.2	40	12	-	-	-	G $\frac{3}{8}$
63		121	142	90 ±0.25			G $\frac{1}{2}$			
80		151.5	188	112 ±0.5/-0.2			-			

∅ [mm]	H1	H5	H7	H8	H10	H11	H12	H13	L1 +0.9/-0.2	L2 +0.3/-0.6
32	72	27	77.5	18.5	93.1	-	49.5	34.1	250	125
40	86	32	90.5	20	106.6	23.1	54	36.1	300	150
50	115	45	122.5	26	-	-	-	-	350	175
63	131	53	144.5	30					400	200
80	174	65	175	36.5					520	260

∅ [mm]	L17	L18 ±0.03	L19 ±0.03	L20	L21 ±0.1	L23	L24	L25	T4 max.	T5
32	131 ±0.2	40	-	261	40	131	-	-	12.5	-
40	167 ±0.2		40	337	167	150	58	7		
50	202 ±0.2		402	80	-	-	-	18.5	-	
63	230 ±0.2		480	120	-	-	-	20.5	-	
80	320 -0.3		-	-	-	-	-	27	-	

Linear drives DGPL, with guide

Technical data – Clamping unit



Clamping unit DGPL-...-KU

The clamping unit is clamped in the unpressurised state.



General technical data					
Piston Ø		18	25	32	40
Constructional design	Spring actuated clamping profile				
Stroke	[mm]	10 ... 1800	10 ... 3000		

Operating and environmental conditions					
Piston Ø		18	25	32	40
Operating pressure	[bar]	4 ... 8			
Grade of filtration	[µm]	40			
Pneumatic connection		G $\frac{1}{8}$			
Ambient temperature ¹⁾	[°C]	-10 ... +60			

1) Note for proximity sensors.

Clamping unit weights [kg]					
Piston Ø		18	25	32	40
Basic weight with 0 mm stroke		0.388	0.649	0.985	1.446
Additional weight per 10 mm stroke		0.018	0.026	0.034	0.041
Moving load with 0 mm stroke		0.061	0.120	0.153	0.213

Materials

Sectional view

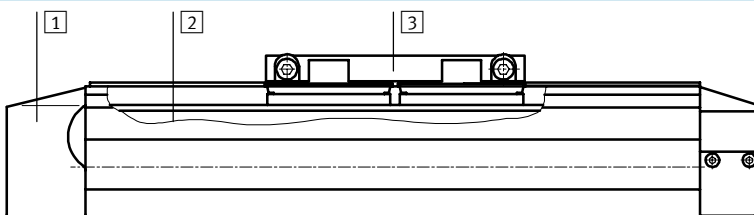

Clamping unit	
1	Housing Anodised aluminium
2	Clamping profile Anodised aluminium
3	Driver Anodised aluminium
-	Cover Acrylic butadiene styrene
-	Seals Polyurethane

Linear drives DGPL, with guide

Technical data – Clamping unit

Clamping unit DGP...-...-K...

Holding force F_H of the clamping unit dependent on the stroke l

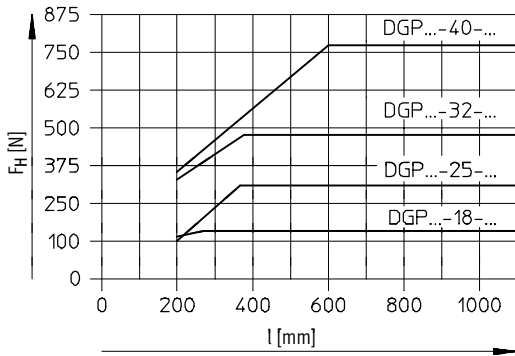

Note
 Environmental conditions:
 Clamping surfaces oil, grease and dirt-free

Dimensions

Download CAD data → www.festo.com/en/engineering

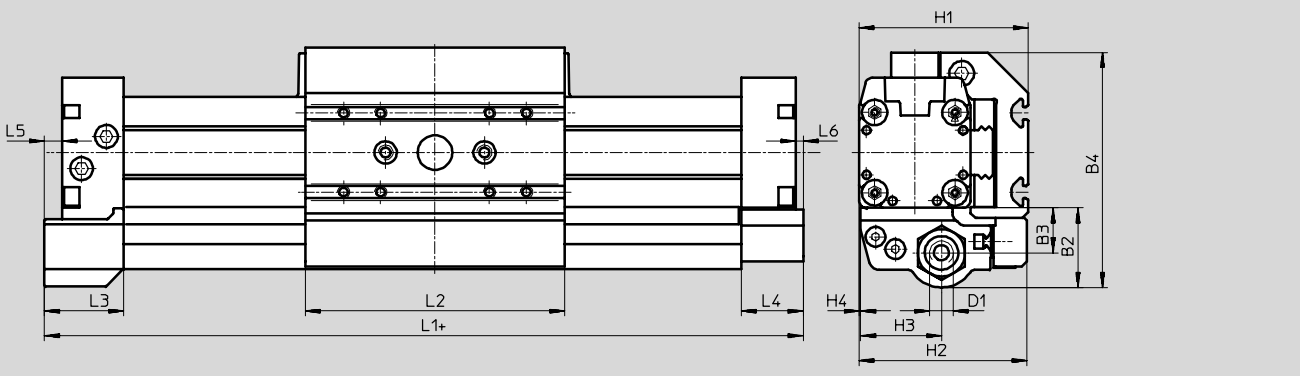

Note
 Clamping units DGP...-...-K... have a supply port at one end only.

for \varnothing	B1	B2	B3	B4	D1	H1	H2	H3	H4	H5	H6	L1	L2	L3	L4	L5	L6
[mm]	max.	max.	max.	max.						± 0.1							
18	–	31.2	17.2	81	G $\frac{1}{8}$	57	56.7	28.5	0.5	8.2	–	176	85	32	25	16.5	9.5
25		33.3	19.3	96.3		68.5	67.8	32.7	0.6	5.9	–	207	105			7	–
32		32.7	17.7	104.7		77.5	76.8	41	1	5.9	–	251	131		31	1	–
40		37.1	23.1	123.1		90.5	90	54.6	1.7	5.4	–	301	167				

Linear drives DGPL, with guide

Ordering data

Ordering data – Standard stroke		
Piston Ø	Part No.	Type
25	526 649	DGPL-25-250-PPV-A-B-KF
	526 650	DGPL-25-400-PPV-A-B-KF
	526 651	DGPL-25-500-PPV-A-B-KF
	526 652	DGPL-25-1000-PPV-A-B-KF
32	526 657	DGPL-32-250-PPV-A-B-KF
	526 658	DGPL-32-400-PPV-A-B-KF
	526 659	DGPL-32-500-PPV-A-B-KF
	526 660	DGPL-32-1000-PPV-A-B-KF
40	526 665	DGPL-40-250-PPV-A-B-KF
	526 666	DGPL-40-400-PPV-A-B-KF
	526 667	DGPL-40-500-PPV-A-B-KF
	526 668	DGPL-40-1000-PPV-A-B-KF

Ordering data – Variable stroke for plain-bearing guide GF		
Piston Ø	Part No.	Type
18	161 974	DGPL-...-PPV-A-GF-B
25	161 786	DGPL-...-PPV-A-GF-B
32	161 787	DGPL-...-PPV-A-GF-B
40	161 788	DGPL-...-PPV-A-GF-B
50	161 789	DGPL-...-PPV-A-GF-B
63	161 790	DGPL-...-PPV-A-GF-B
80	161 791	DGPL-...-PPV-A-GF-B

Ordering data – Variable stroke for recirculating ball bearing guide KF		
Piston Ø	Part No.	Type
18	161 977	DGPL-...-PPV-A-KF-B
25	161 792	DGPL-...-PPV-A-KF-B
32	161 793	DGPL-...-PPV-A-KF-B
40	161 794	DGPL-...-PPV-A-KF-B
50	161 795	DGPL-...-PPV-A-KF-B
63	161 796	DGPL-...-PPV-A-KF-B
80	161 797	DGPL-...-PPV-A-KF-B

Ordering data – Wearing parts kits		
Piston Ø	Part No.	Type
18	384 266	DGPL-18-...-PPV-A
25	123 563	DGPL-25-...-PPV-A
32	123 564	DGPL-32-...-PPV-A
40	123 565	DGPL-40-...-PPV-A
50	123 566	DGPL-50-...-PPV-A
63	123 567	DGPL-63-...-PPV-A
80	123 568	DGPL-80-...-PPV-A

 Note
 Piston Ø 8 and 12
 Linear drives DGC
 → Info 119

Linear drives DGPL, with guide

Ordering data – Modular products

Order code

Mandatory data

GK	Standard slide	D2	Supply port
GV	Extended slide	KU	Clamping unit underneath
SH	Slide at rear	CT	Free of copper and PTFE
SV	Slide at front		

Standard slide GK
Extended slide GV

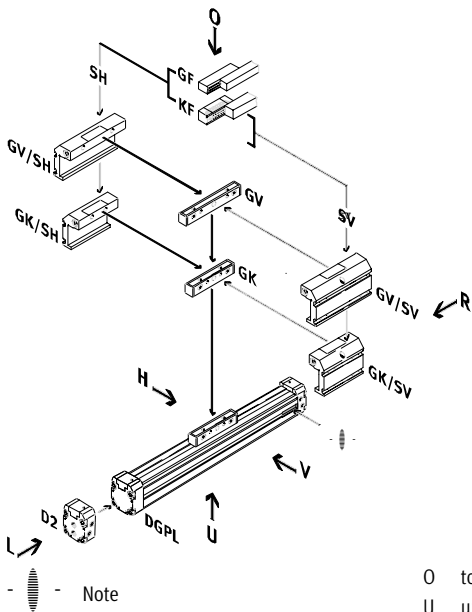

- Note

The insertion point for the proximity sensor is located on the right-hand side of the pneumatic linear drive DGPL.

- O top
- U underneath
- R right
- L left
- V front
- H rear

Clamping unit KU

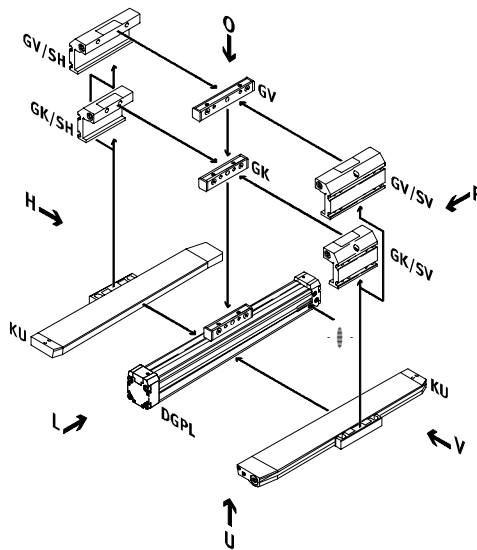

Options

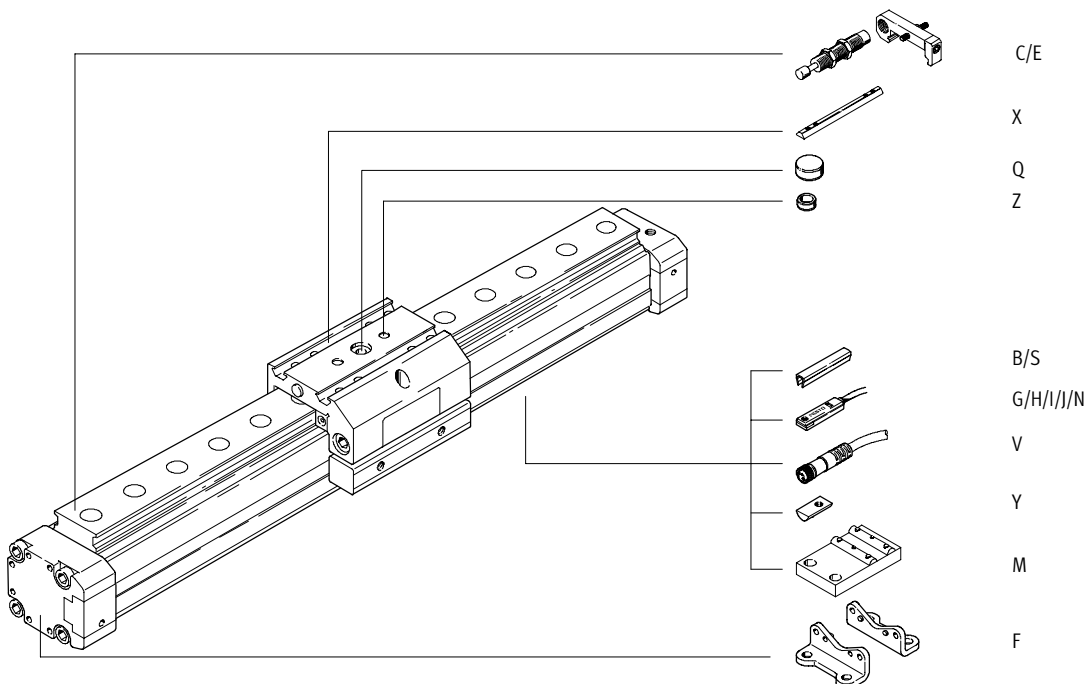

Linear drives DGPL, with guide

Ordering data – Modular products

M Mandatory data								O Options →			
Module No.	Drive function	Size	Stroke	Cushioning	Position sensing	Generation	Guide	Clamping unit	Basic design	Slide attachment position	Supply port
175 131	DGPL	18	10 ... 3000	P	A	B	GF	KU	GK	SV	D2
175 132		25		PPV					GV	SH	
175 133		32									
175 134		40									
175 135		50									
175 136		63									
175 137		80									
175 138											
175 139											
Ordering example											
175 138	DGPL	63	800	PPV	A	B	KF		GK	SH	D2

Ordering table											
Size	18	25	32	40	50	63	80	Condi- tions	Code	Enter code	
M Module No.	175 133	175 134	175 135	175 136	175 137	175 138	175 139				
Drive function	Pneumatic linear drive								DGPL	DGPL	
Size	18	25	32	40	50	63	80		-...		
Stroke [mm]	10 ... 1800	10 ... 3000								-...	
Cushioning	Pneumatic cushioning adjustable at both ends								-PPV		
Position sensing	Via magnet								-A	-A	
Generation	B series								-B	-B	
Guide	Plain-bearing guide								-GF		
	Recirculating ball bearing guide								-KF		
O Clamping unit	Underneath						-	-	-	1	-KU
Basic design	Standard piston/slide									-GK	
	Extended piston/slide							-	1	-GV	
Slide attachment position	At rear									-SH	
	At front									-SV	
Supply port	At both ends									-D2	

1 KU, GV Not with protected version GA and special material CT.

Transfer order code

DGPL - - - - **A** - **B** - - - - - - -

Linear drives DGPL, with guide

Ordering data – Modular products



Options											
Special materials	Protected version	Accessories	Slot cover	Slot nut	Centring sleeve	Central support	Central mounting	Foot mounting	Proximity sensor	Plug socket	Shock absorber kit
CT	GA	ZUB	...S ...B	...X ...Y	...Z	...M	...Q	...F	...G ...H ...I ...J ...N	...V	...C ...E
- CT	-	: ZUB	- 2S2B	5Y2X	20Z		Q	F	2G		2C

Ordering table											
Size	18	25	32	40	50	63	80	Conditions	Code	Enter code	
Special materials	Free of copper and PTFE								-CT		
Protected version	Protected roller bearing design for harsh environment							[3]	-GA		
Accessories	Supplied separately								:ZUB-	:ZUB-	
Slot cover, 2 pcs., 0.5 m	Sensor slot	1 ... 10							...S		
	Mounting slot	-	-	1 ... 10					...B		
Slot nut	Slide	-	1 ... 10						...X		
	Mounting slot	-	-	1 ... 10					...Y		
Centring sleeve (pack of 10)	10, 20, 30, 40, 50, 60, 70, 80, 90								...Z		
Central support	1 ... 10								...M		
Central mounting	-		1 ... 10						...Q		
Foot mounting	1 ... 10								...F		
Proximity sensor, magnetic	with cable, 2.5 m	1 ... 10 (SME-8-K-LED-24)								...G	
	with plug	1 ... 10 (SME-8-S-LED-24)								...H	
Proximity sensor, magnetic, contactless	with cable, 2.5 m	1 ... 10 (SMT-8-PS-K-LED-24)								...I	
	with plug	1 ... 10 (SMT-8-PS-S-LED-24)								...J	
Proximity sensor, magnetic	NC contact with cable, 2.5 m	1 ... 10 (SME-8-O-K-LED-24)								...N	
Plug socket	with cable, 2.5 m	1 ... 10 (SIM-M8-3GD-2,5-PU)								...V	
Shock absorber kit	1 ... 10								...C		
	1 ... 10							[4]	...E		

[3] GA Only with recirculating ball bearing guide KF.

[4] E Only with protected version GA.

Transfer order code

- [] - [] : ZUB - [] [] [] [] [] [] [] [] [] []

Linear drives DGPL-HD, with heavy-duty guide

Peripherals overview

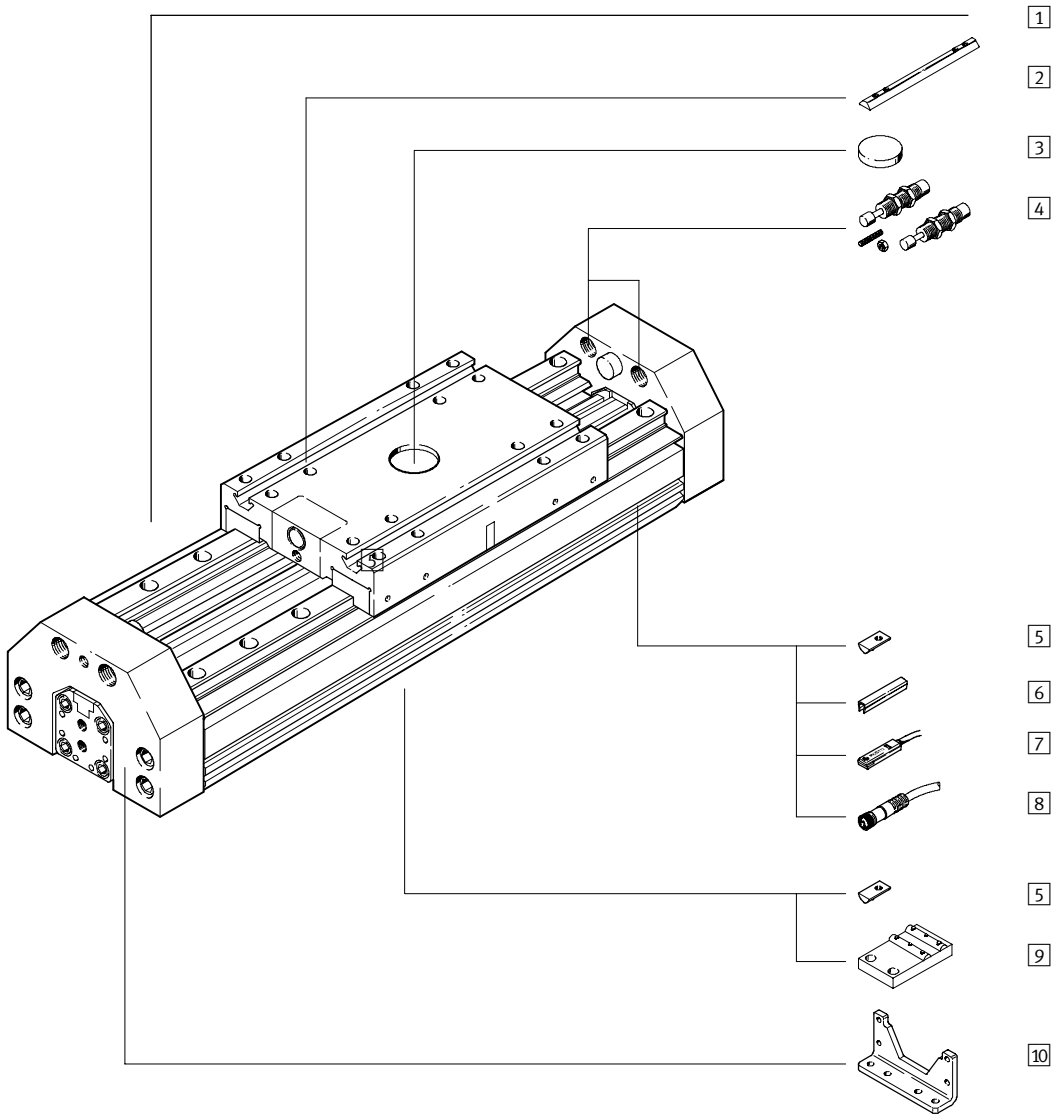

Linear drives DGPL-HD, with heavy-duty guide

Peripherals overview

Variants and accessories		
Type	Brief description	→ Page
1 Linear axis DGPL-HD	Pneumatic linear drive with heavy-duty guide	50
2 Slot nut for slide X	For mounting loads and attachments on the slide	68
3 Central mounting Q	For centring loads and attachments on the slide	68
4 Shock absorber kit D	For slowing higher speeds to a stop	66
5 Slot nut for side mounting slot Y	For mounting attachments	68
6 Slot cover B/S	For protecting against ingress of dirt	68
7 Proximity sensor G/H/I/J/N	For sensing the slide position	69
8 Plug socket with cable V	For proximity sensors	69
5 Slot nut for mounting slot underneath U	For mounting attachments	68
9 Central support M	For mounting the axis	62
10 Foot mounting F	For mounting the axis	62

Linear drives DGP-HD, with heavy-duty guide

Type code

	DGPL	-	25	-	500	-	PPV	-	A	-	B	-	GK	-	D2	-	CT
Type	DGPL	Linear drive with heavy-duty guide															
Piston \varnothing		25															
Stroke [mm]		500															
Cushioning	PPV	Adjustable end-position cushioning															
Position sensing	A	Via magnet															
Generation	B	B series															
Basic design	GK	Standard slide															
Supply port	D2	Supply port at both ends															
Special materials	CT	Free of copper and PTFE															

Linear drives DGP-HD, with heavy-duty guide

Type code

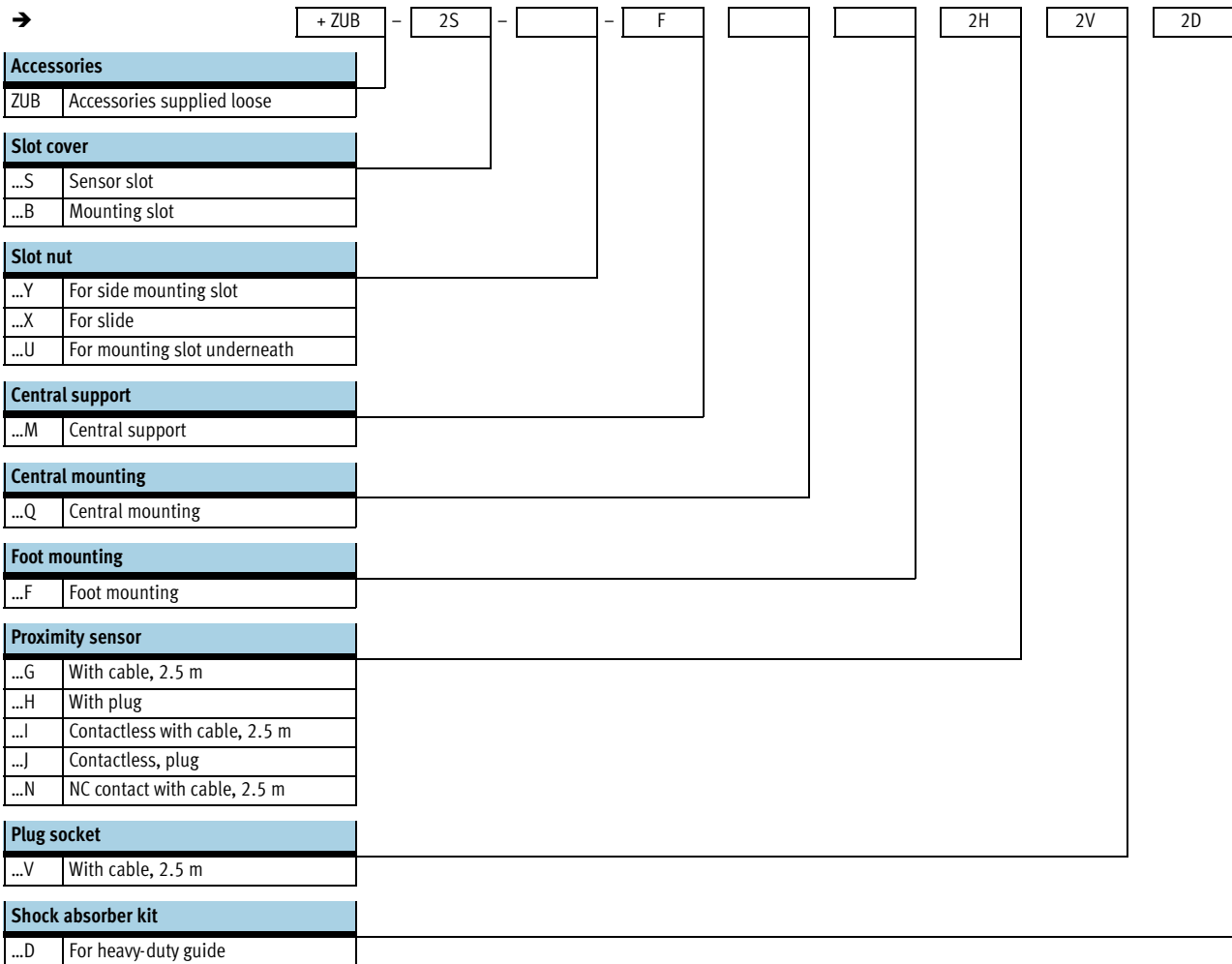

Linear drives DGPL-HD, with heavy-duty guide

Technical data

Function

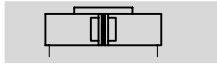

 Spare parts service

Wearing parts kits
→ 57

-  - Diameter
18 ... 80 mm

-  - Stroke length
10 ... 2160 mm

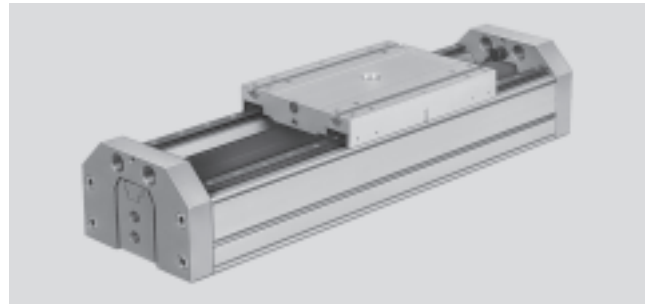

General technical data						
Piston Ø	18-HD18	18-HD25	25-HD25	25-HD40	32-HD40	40-HD40
Constructional design	Pneumatic linear drive with heavy-duty guide					
Protection against torsion/guide	Slotted profile barrel/recirculating ball bearing guide					
Mode of operation	Double-acting					
Driver principle	Positive-locking (slot)					
Mounting position	Any					
Pneumatic connection	M8		G ¹ / ₈		G ¹ / ₄	
Stroke length [mm]	10 ... 1710	10 ... 1640	10 ... 2160	10 ... 2110		
Cushioning P	Non-adjustable at both ends Self-adjusting at both ends					
Cushioning length [mm]	-					
Position sensing	Via magnet					
Max. speed [m/s]	3					

Operating and environmental conditions						
Piston Ø	18-HD18	18-HD25	25-HD25	25-HD40	32-HD40	40-HD40
Operating medium	Filtered compressed air, lubricated or unlubricated					
Operating pressure [bar]	2 ... 8					1.5 ... 8
Ambient temperature ¹⁾ [°C]	-10 ... +60					

1) Note operating range of proximity sensors.

Forces [N]						
Piston Ø	18-HD18	18-HD25	25-HD25	25-HD40	32-HD40	40-HD40
Theoretical force at 6 bar	153		295		483	754

Weights [kg]						
Piston Ø	18-HD18	18-HD25	25-HD25	25-HD40	32-HD40	40-HD40
Basic weight with 0 mm stroke	3.7	4.4	5.1	13.9	14.4	15.4
Additional weight per 10 mm stroke	0.089	0.133	0.152	0.212	0.217	0.233
Moving load	0.530	1.86	1.96	3.48	3.615	3.850

Linear drives DGPL-HD, with heavy-duty guide

Technical data

Materials

Sectional view

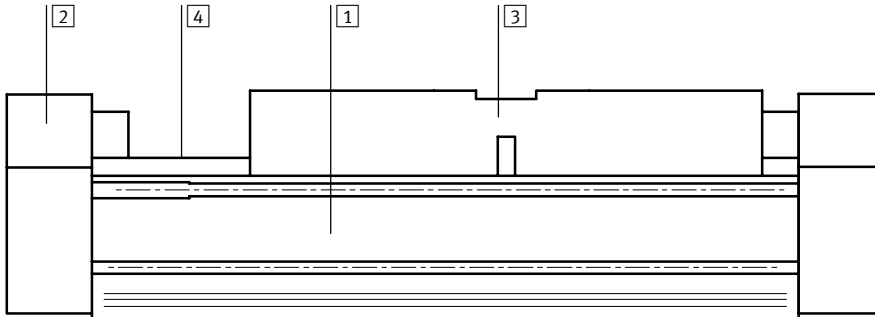

Axis		
1	Profile	Anodised aluminium
2	End cap	Anodised aluminium
3	Slide	Anodised aluminium
4	Guide rail	Steel
-	Seals	Nitrile rubber, polyurethane

Characteristic load values for drive with heavy-duty guide HD

The indicated forces and torques refer to the centre of the heavy-duty guide. They must not be exceeded in the dynamic range. Special attention must be paid to the cushioning phase.

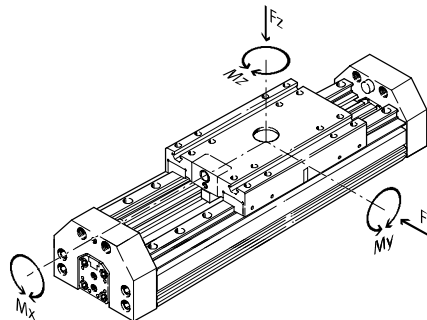

If the drive is subjected to more than two of the indicated forces and torques simultaneously, the following equations must be satisfied in addition to the indicated maximum loads:

$$\frac{F_y}{F_{y_{max}}} + \frac{F_z}{F_{z_{max}}} + \frac{M_x}{M_{x_{max}}} + \frac{M_y}{M_{y_{max}}} + \frac{M_z}{M_{z_{max}}} \leq 1$$

Permissible forces and torques				
Piston Ø		HD-18	HD25	HD-40
F _y _{max.}	[N]	1820	5400	5400
F _z _{max.}	[N]	1820	5600	5600
M _x _{max.}	[Nm]	70	260	375
M _y _{max.}	[Nm]	115	415	560
M _z _{max.}	[Nm]	112	400	540

Linear drives DGPL-HD, with heavy-duty guide

Technical data

Maximum permissible support span l as a function of the force F

The axis may need to be supported with central supports MUP in order to restrict deflection with long stroke lengths. The following diagrams serve to determine the maximum permissible support span l as a function of the force F acting upon the axis.

Force on the surface of the slide

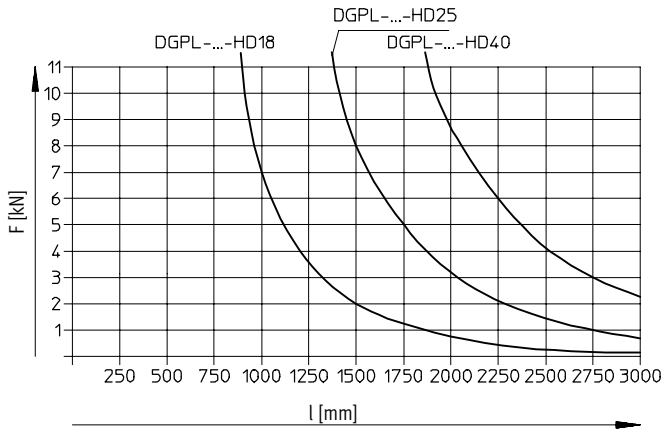
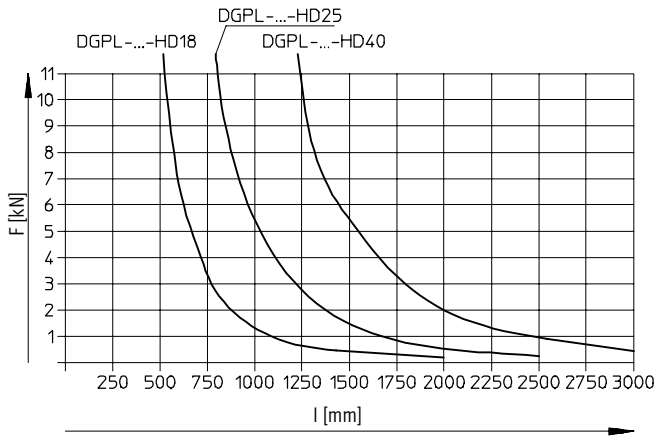
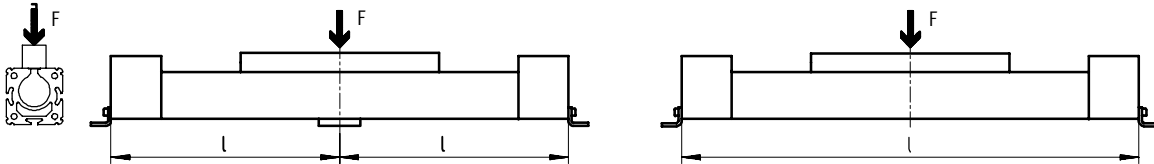

Linear drives DGPL-HD, with heavy-duty guide

Technical data

Dimensions

Download CAD data → www.festo.com/en/engineering

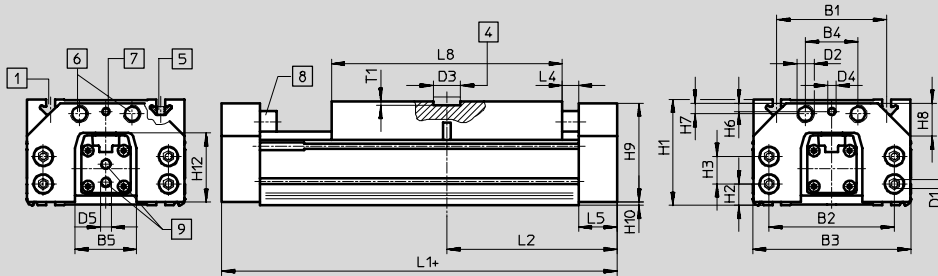

- 1 Mounting slot for slot nut NSTH
 - 2 Mounting slot for slot nut NST
 - 3 Sensor slot for proximity sensor
 - 4 Central mounting SLZZ
 - 5 Slot nut NSTH
 - 6 Thread for shock absorber YHD or YSR...-C
 - 7 Thread for threaded pin (shock absorber kit)
 - 8 Rubber buffer
 - 9 Supply port at one end (D2 variant: supply port at both ends)
- + = plus stroke length

Profile

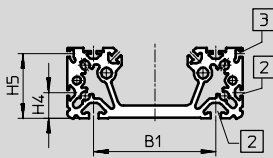

Heavy-duty guide [mm]	B1	B2 ±0.2	B3	B4	B5	D1	D2	D3 ∅ G7	D4	D5	H1	H2	H3	H4
18-HD18	80 ±0.3	85	116	40	36	M5	M12x1	25	M6	M5	69.9	12.8	19.5 ±0.1	14
18-HD25	100 ±0.3	114	144	48	56 ±0.5	M8	M16x1		M8	G1/8	93.5	18.5	25 ±0.2	21
25-HD25	140 ±0.35	156	185	54	68		M22x1.5				124.5	21	48 ±0.2	35
25-HD40														
32-HD40														
40-HD40														

Heavy-duty guide [mm]	H5	H6	H7	H8	H9	H10	H12	L1	L2	L4	L5	L8	T1
18-HD18	42.3	5.9	8.7	20x45°	68	0.8	49	240	120	15	25	160	3.5
18-HD25	52.8	9	9.75	30x45°	90	2	63	310	155		35	210	
25-HD25	82.8	5.5	15.5	35x45°	120		89	354	177		32	260	4
25-HD40													
32-HD40													
40-HD40													

Linear drives DGPL-HD, with heavy-duty guide

Ordering data – Modular products

Order code

Mandatory data

GK	Standard slide
D2	Supply port
CT	Free of copper and PTFE

With heavy-duty guide HD

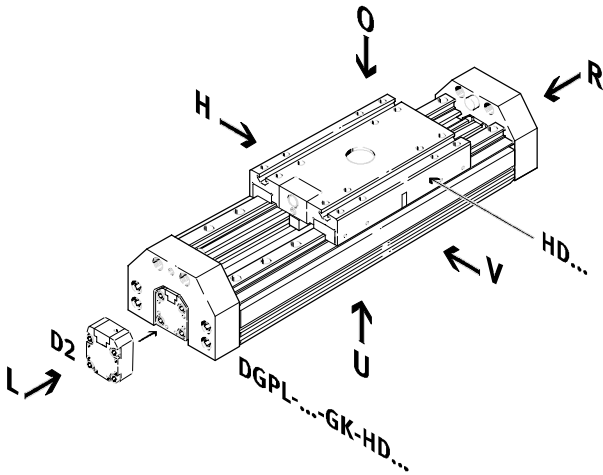

-  - Note

The insertion point for the proximity sensor is located at the left-hand side of the heavy-duty guide

- O top
- U underneath
- R right
- L left
- V front
- H rear

Ordering data – Wearing parts kits

Piston Ø	Part No.	Type
18	384 266	DGP-18-...-PPV-A
25	123 563	DGP-25-...-PPV-A
32	123 564	DGP-32-...-PPV-A
40	123 565	DGP-40-...-PPV-A
50	123 566	DGP-50-...-PPV-A
63	123 567	DGP-63-...-PPV-A
80	123 568	DGP-80-...-PPV-A

Linear drives DGPL-HD, with heavy-duty guide

Ordering data – Modular products

Order code

Options

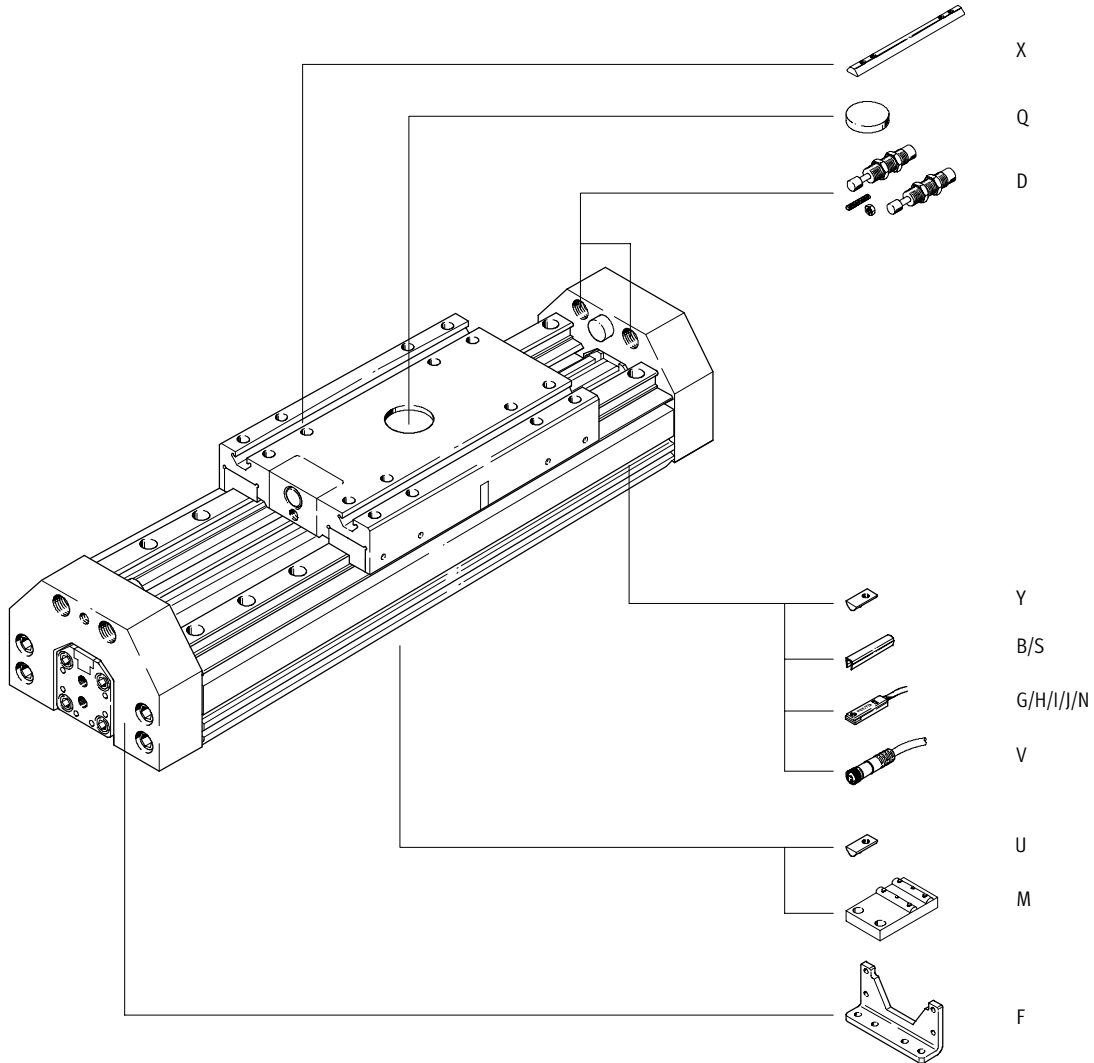

Linear drives DGP-HD, with heavy-duty guide

Ordering data – Modular products

M Mandatory data						O Options →		
Module No.	Drive function	Size	Stroke	Cushioning	Position sensing	Guide	Basic design	Supply port
175 133	DGPL	18	10 ... 2160	PPV	A	HD18	GK	D2
175 134		25				HD25		
175 135		32				HD40		
175 136		40						
Ordering example								
175 134	DGPL	25	800	PPV	A	HD25	GK	D2

Ordering table								
Size	18	25	32	40	Condi-tions	Code	Enter code	
M Module No.	175 133	175 134	175 135	175 136				
Drive function	Pneumatic linear drive with heavy-duty guide						DGPL	DGPL
Size	18	25	32	40		-...		
Stroke [mm]	HD18	10 ... 1710	-	-		-...		
	HD25	10 ... 1650	10 ... 2160	-		-...		
	HD40	-	10 ... 2110	-		-...		
Cushioning							-PPV	-PPV
Position sensing	Via magnet						-A	-A
Guide	Heavy-duty guide HD	HD18	-	-	-		-HD18	
		HD25	-	-	-		-HD25	
	-	HD40	-	-	-		-HD40	
O Basic design	Standard piston/slide						-GK	
Supply port	At both ends						-D2	

Transfer order code

DGPL - - - **PPV** - **A** - - - -

Linear drives DGPL-HD, with heavy-duty guide

Ordering data – Modular products

Options									
Special materials	Accessories	Slot cover	Slot nut	Central support	Central mounting	Foot mounting	Proximity sensor, magnetic	Plug socket	Shock absorber kit
CT	ZUB	...S ...B	...X ...Y ...U	...M	...Q	...F	...G ...H ...I ...J ...N	...V	...D
- CT	: ZUB	- 2S2B	2X5Y5U		2Q	F	2G		2D

Ordering table										
Size		18	25	32	40	Condi- tions	Code	Enter code		
↓	Special materials	Free of copper and PTFE						-CT		
0	Accessories	Supplied separately						:ZUB-	:ZUB-	
	Slot cover, 2 pcs., 0.5 m	Sensor slot	1 ... 10				...S			
		Mounting slot	1 ... 10				...B			
	Slot nut	Slide	1 ... 10				...X			
		Mounting slot	1 ... 10				...Y			
		Mounting slot underneath	1 ... 10				...U			
	Central support	1 ... 10				...M				
	Central mounting	1 ... 10				...Q				
	Foot mounting	1 ... 10				...F				
	Proximity sensor, magnetic	with cable, 2.5 m	1 ... 10 (SME-8-K-LED-24)				...G			
		with plug	1 ... 10 (SME-8-S-LED-24)				...H			
	Proximity sensor, magnetic, contactless	with cable, 2.5 m	1 ... 10 (SMT-8-PS-K-LED-24)				...I			
		with plug	1 ... 10 (SMT-8-PS-S-LED-24)				...J			
	Proximity sensor, magnetic	NC contact with cable, 2.5 m	1 ... 10 (SME-8-O-K-LED-24)				...N			
	Plug socket	with cable, 2.5 m	1 ... 10 (SIM-M8-3GD-2,5-PU)				...V			
	Shock absorber kit	1 ... 10				...D				

Transfer order code

- [] : ZUB - [] [] [] [] [] [] [] [] [] [] []

Linear drives DGP/DGPL

Accessories

FESTO

Foot mounting HP
(order code F)

Material:
Galvanised steel
Free of copper and PTFE

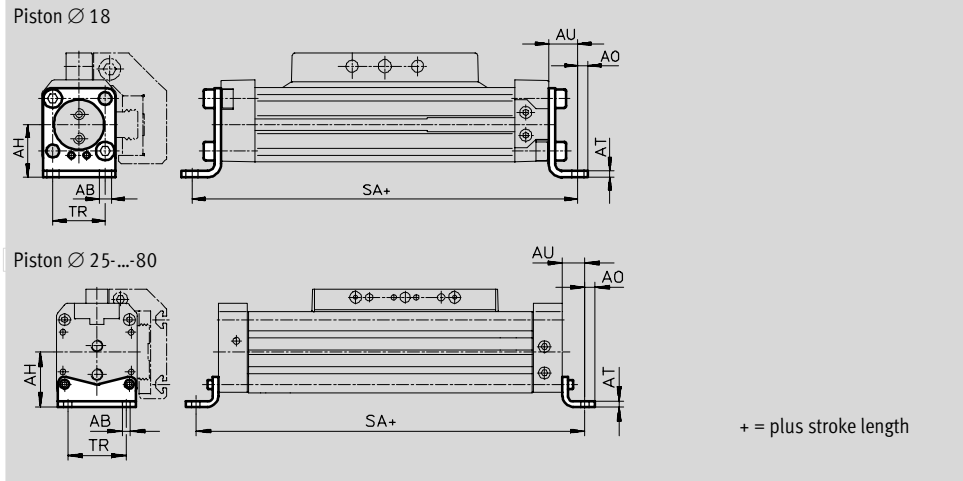

Dimensions and ordering data											
for \varnothing	AB \varnothing	AH	AO	AT	AU	SA		TR	Weight [g]	Part No.	Type
						GK	GV				
[mm]											
18	5.5	24	4.8	3	13.2	176.5	256.4	24	59	158 472	HP-18
25	5.5	29.5	6	3	13	226	326	32.5	61	150 731	HP-25
32	6.6	37	7	4	17	284	414	38	117	150 732	HP-32
40	6.6	46	8.5	5	17.5	335	505	45	188	150 733	HP-40
50	9	61	11	6	25	400	600	65	243	150 734	HP-50
63	11	69	13.5	6	28	456	706	75	305	150 735	HP-63
80	13	85	12	8	28	576	-	72	620	158 453	HP-80

Core Range

Linear drives DGP/DGPL

Accessories

Central support MUP (order code M)

Material:
Galvanised steel
Free of copper and PTFE



Piston \varnothing 18 and 25

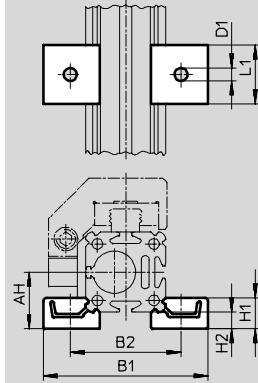

Piston \varnothing 32 ... 63

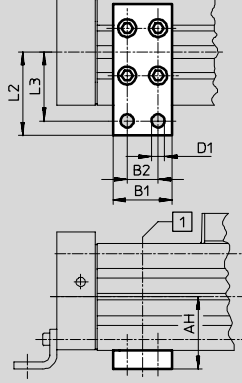

1 Position of the central support along the profile barrel is freely selectable

Dimensions and ordering data												
for \varnothing	AH	B1	B2	D1	H1	H2	L1	L2	L3	Weight	Part No.	Type
[mm]				\varnothing						[g]		
18	24	70.5	47	5.5	13	7	25	-	-	29	150 736	MUP-18/25
25	29.5	81	58	5.5	13	7	25	-	-	33	150 736	MUP-18/25
32	37	35	22	6.6	-	-	-	41.5	35	89	150 737	MUP-32
40	46	35	22	6.6	-	-	-	47	40	126	150 738	MUP-40
50	61	50	26	11	-	-	-	70	58	241	150 739	MUP-50
63	69	50	26	11	-	-	-	77	65	340	150 800	MUP-63
80	85	50	26	11	-	-	-	88	76	590	158 455	MUP-80

Linear drives DGP/DGPL

Accessories



Foot mounting HHP

for heavy-duty guide
(order code F)

Material:

Galvanised steel



Central support MUP

for heavy-duty guide
(order code M)

Material:

Galvanised steel

Free of copper and PTFE



DGPL-...-HD18/-HD25/-HD40

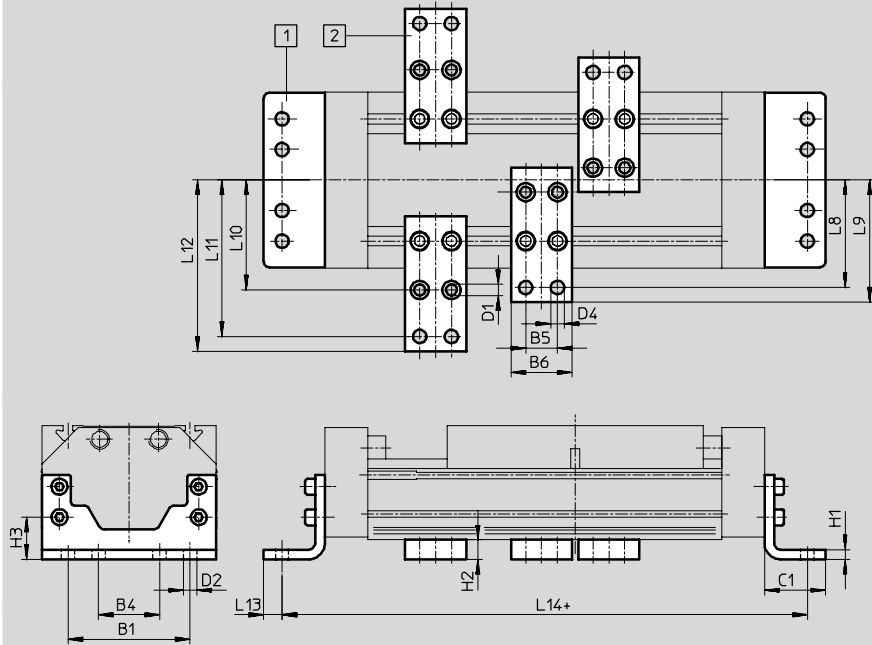

- 1 Foot mounting HHP
- 2 Central support MUP

+ = plus stroke length

Dimensions and ordering data											
for heavy-duty guide [mm]	B1	B4	B5	B6	C1	D1 ∅	D2 ∅	D4 ∅	H1	H2	H3
HD18	80	40	22	35	34	5.5	6.6	6.6	8	14	26.8
HD25	100	50	26	50	50	9	11	11	8	16	34.5
HD40	140	70	26	50	50	9	11	11	10	16	37

for heavy-duty guide [mm]	L8	L9	L10	L11	L12	L13	L14	Weight [g]	Part No.	Type
HD18	68	75	64	92	99	9	290	357	161 993	HHP-18
								126	150 738	MUP-40
HD25	88	100	90	128	140	15	380	794	161 994	HHP-25
								347	150 739	MUP-50
HD40	108	120	110	148	160	15	424	1 318	161 995	HHP-40
								347	150 739	MUP-50

Core Range

Linear drives DGP/DGPL

Accessories



Load inverter AK
for DGP
(order code AK)

Material:
Galvanised steel

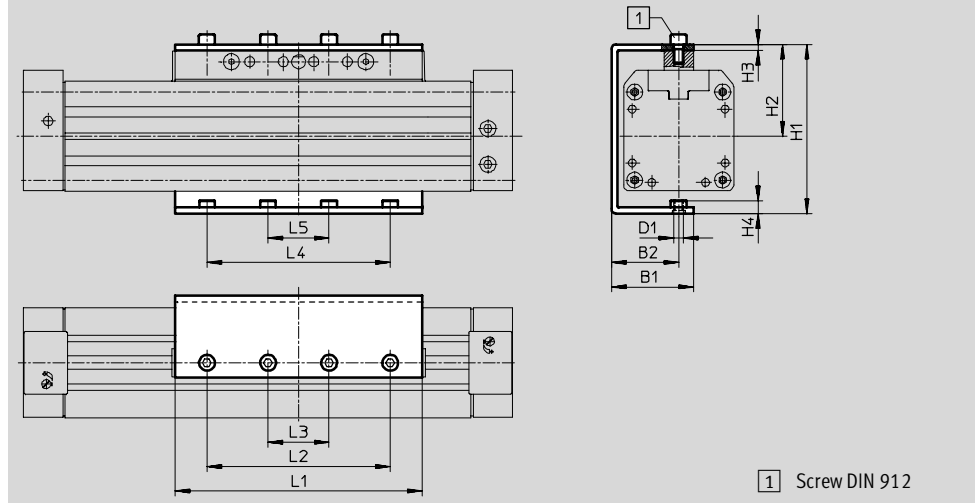
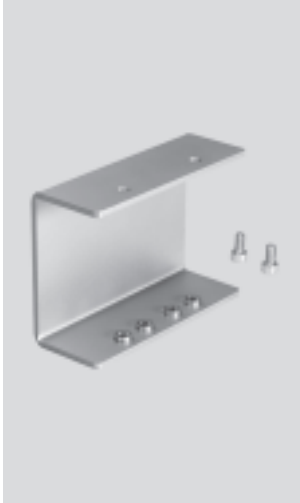

Dimensions and ordering data									
for Ø	B1	B2	D1	H1	H2	H3	H4	L1	L2
[mm]									
18	29	23	M5	62.7	35.8	3	5	79.6	–
25	39	29.5	M5	76.1	43.5	3	5	105	–
32	43.5	34	M5	87	49	4	6	131	100
40	50.5	40	M6	104	58	4	8.1	167	130
50	67	55	M8	138.5	75	5	10.5	202	150
63	77	65	M8	156.5	84	6	11.5	230	190

for Ø	L3	L4	L5	1	CRC ¹⁾	Weight	Part No.	Type
[mm]						[g]		
18	60	60	20	M5x12	2	227	196 105	AK-18
25	50	50	20	M5x10		380	196 106	AK-25
32	30	100	30	M5x12		690	196 107	AK-32
40	40	130	40	M6x14		1050	196 108	AK-40
50	50	150	50	M8x16		2080	196 109	AK-50
63	70	190	70	M8x18		2820	196 110	AK-63

1) Corrosion resistance class 2 according to Festo standard 940 070
Components requiring moderate corrosion resistance. Externally visible parts with primarily decorative surface requirements which are in direct contact with a surrounding industrial atmosphere or media such as cooling or lubricating agents.

Linear drives DGP/DGPL

Accessories



Moment compensator FKP

for DGP

(order code FK)

Material:

Galvanised steel

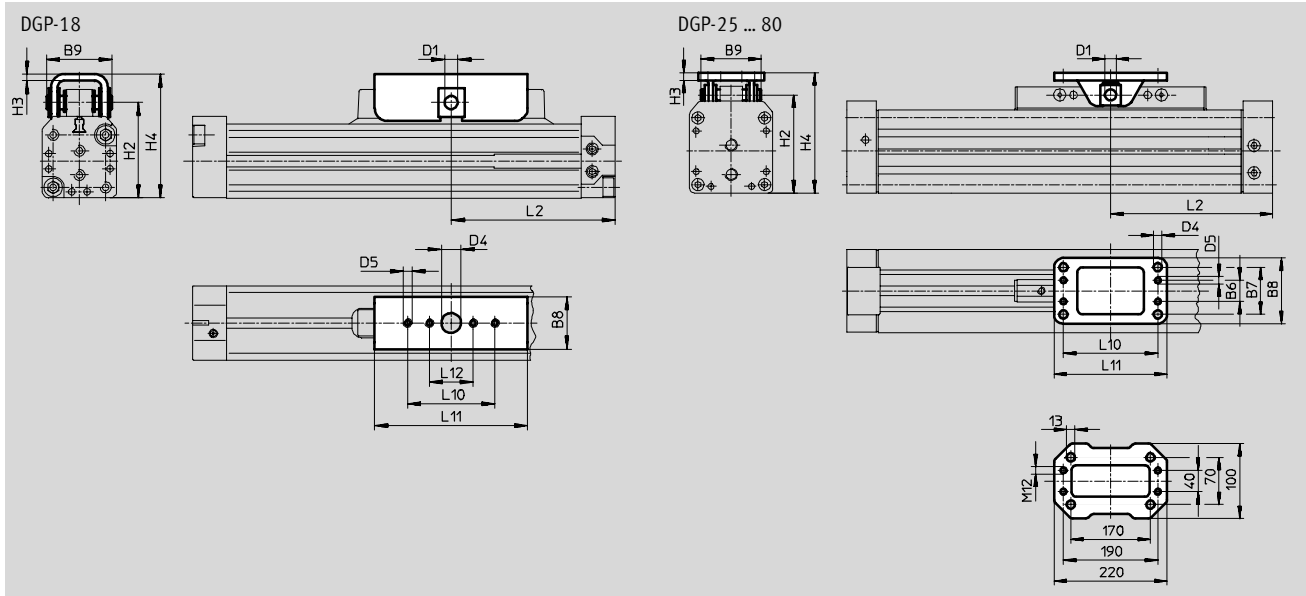

Dimensions and ordering data																
for \varnothing	B6	B7	B8	B9	D1	D4	D5	H2	H3	H4	L2	L10	L11	L12	Part No.	Type
[mm]					\varnothing	\varnothing										
18	-	-	26	30	6	9	M4	43.8	3	57.8	75	40	70	20	158 474	FKP-18
25	20	40	54	50	8	5.5	M5	57	5	75	100	66	80	-	150 801	FKP-25/32
32	20	40	54	50	8	5.5	M5	66	5	84	125	66	80	-	150 801	FKP-25/32
40	24	44	58	60	10	6.5	M6	78	6	99	150	76	90	-	150 802	FKP-40
50	23	51	71	63	12	9	M8	106	8	130	175	102	122	-	150 803	FKP-50/63
63	23	51	71	63	12	9	M8	122	8	146	200	102	122	-	150 803	FKP-50/63
80	-	-	-	94	20	-	-	158	13	194.5	258	-	-	-	158 457	FKP-80

Core Range

Linear drives DGP/DGPL

Accessories

Shock absorber YSR-...-C

for DGPL
(order code C)

Material:

Housing: galvanised steel; piston rod: high-alloy steel,
seals: nitrile rubber, polyurethane
Free of copper and PTFE



Note
Shock absorber YSRW with progressive characteristics
→ www.festo.com

Ordering data		Part No.	Type
for Ø [mm]	Weight [g]		
18	50	34 571	YSR-8-8-C
25	70	34 572	YSR-12-12-C
32	70	34 572	YSR-12-12-C
40	140	34 573	YSR-16-20-C
50	140	34 573	YSR-16-20-C
63	240	34 574	YSR-20-25-C
80	240	34 574	YSR-20-25-C

Shock absorber retainer KYP

for DGPL
(order code C)

Material:

Retainer: Aluminium
Sleeve: Corrosion resistant steel

Shock absorber not included in scope of delivery.

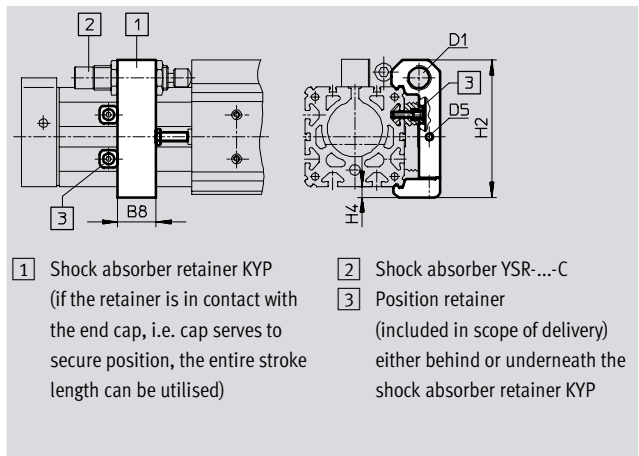

Dimensions and ordering data							
for Ø	B8	D1	D5	H2	H4	Weight [g]	Part No. Type
18	14	M12x1	M4	50.5	4.5	65	158 907 KYP-18
25	19	M16x1	M5	69.5	6	95	158 908 KYP-25
32	25	M16x1	M5	80	8	130	158 909 KYP-32
40	32	M22x1.5	M5	102	8	209	158 910 KYP-40
50	35	M22x1.5	M8	124	10	415	158 911 KYP-50
63	44	M26x1.5	M10	152.5	11.5	609	158 912 KYP-63
80	44	M26x1.5	M10	179.5	11.5	774	158 913 KYP-80

Core Range

Linear drives DGP/DGPL

Accessories



Shock absorber DG-GA

in end position

for DGPL

protected version GA

(order code E)

Material:

Housing: galvanised steel; piston rod:

high-alloy steel,

seals: nitrile rubber, polyurethane

Free of copper and PTFE



 Note
Entire stroke can be used.

Ordering data			
for \varnothing	Weight [g]	Part No.	Type
25	70	192 875	DG-GA-25-YSR
32	93	192 876	DG-GA-32-YSR
40	140	192 877	DG-GA-40-YSR

Shock absorber kit YHD

for heavy-duty guide

(order code D)

Material:

Housing: Galvanised steel

Seals: TPE-U(PU) NBR

Free of copper and Teflon



Ordering data			
for size	Weight [g]	Part No.	Type
18	203	174 544	YHD-18
25	293	174 545	YHD-25
40	515	174 546	YHD-40



Ordering data – One-way flow control valves				Technical data → www.festo.com	
	Connection		Material	Part No.	Type
	Thread	For tubing OD			
	M5	3	Metal design	193 137	GRLA-M5-QS-3-D
		4		193 138	GRLA-M5-QS-4-D
	G $\frac{1}{8}$	4		193 143	GRLA- $\frac{1}{8}$ -QS-4-D
		6		193 144	GRLA- $\frac{1}{8}$ -QS-6-D
	G $\frac{1}{4}$	6		193 146	GRLA- $\frac{1}{4}$ -QS-6-D
		8		193 147	GRLA- $\frac{1}{4}$ -QS-8-D
		8		193 150	GRLA- $\frac{3}{8}$ -QS-8-D
	G $\frac{3}{8}$	10		193 151	GRLA- $\frac{3}{8}$ -QS-10-D
		12		193 152	GRLA- $\frac{1}{2}$ -QS-12-D

 Core Range

Linear drives DGP/DGPL

Accessories

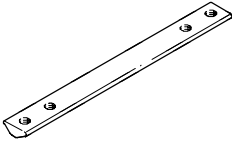
FESTO

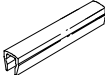
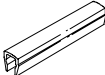
Ordering data for heavy-duty guide DGP/DGPL				Technical data → www.festo.com		
	for Ø [mm]	Remarks	Order code	Part No.	Type	PU ¹⁾
Slot nut NST						
	25	For mounting slot	Y	526 091	NST-HMV-M4	1
	32, 40			150 914	NST-5-M5	1
	50, 63, 80			150 915	NST-8-M6	1
Slot nut NSTL						
	25	For slide	X	158 410	NSTL-25	1
	32			158 411	NSTL-32	1
	40			158 412	NSTL-40	1
	50			158 413	NSTL-50	1
	63			158 414	NSTL-63	1
	80			161 356	NSTL-80	1
Centring pin/sleeve ZBS/ZBH						
	18	For slide	Z	150 928	ZBS-5	10
	25 ... 80			150 927	ZBH-9	10
Central mounting SLZZ						
	25	For slide	Q	150 900	SLZZ-16/10	1
	32, 40			150 901	SLZZ-25/16	
	50 ... 80			150 904	SLZZ-50/40	1
Slot cover ABP						
	32, 40	For mounting slot each 0.5 m	B	151 681	ABP-5	2
	50, 63, 80			151 682	ABP-8	
Slot cover ABP-S						
	18 ... 80	For sensor slot each 0.5 m	S	151 680	ABP-5-S	2





1) Packaging unit quantity

 Core Range

Linear drives DGP/DGPL

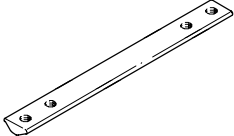
Accessories

FESTO



Ordering data for heavy-duty guide DGPL-HD						
Technical data → www.festo.com						
	for heavy-duty guide [mm]	Remarks	Order code	Part No.	Type	PU ¹⁾
Slot nut NST						
	18	For profile barrel at side	Y	150 914	NST-5-M5	1
	25			150 914	NST-5-M5	1
	40			150 915	NST-8-M6	1
	18	For profile barrel underneath	U	150 914	NST-5-M5	1
	25			150 915	NST-8-M6	1
	40			150 915	NST-8-M6	1
Slot nut NSTH						
	18	For slide	X	161 020	NSTH-18	1
	25			161 021	NSTH-25	1
	40			161 022	NSTH-40	1
Central mounting SLZZ						
	18 ... 40	For slide	Q	150 901	SLZZ-25/16	1
Slot cover ABP						
	18	For mounting slot at side and underneath each 0.5 m	B	151 681	ABP-5	2
	25 underneath			151 681	ABP-5	
	25 at side			151 682	ABP-8	
	40			151 682	ABP-8	
Slot cover ABP-S						
	18 ... 40	For sensor slot each 0.5 m	S	151 680	ABP-5-S	2



1) Packaging unit quantity



Linear drives DGP/DGPL

Accessories

FESTO

Ordering data – Proximity sensors for slot type 8, magneto-resistive							Technical data → www.festo.com		
	Mounting	Switch output	Electrical connection			Cable length [m]	Part No.	Type	
			Cable	Plug M8	Plug M12				
Normally open contact									
	Insertable from above	PNP	3-wire	–	–	2.5	525 898	SMT-8F-PS-24V-K2,5-OE	
				NPN	–		–	525 909	SMT-8F-NS-24V-K2,5-OE
		–	2-wire	–	–	2.5	525 908	SMT-8F-ZS-24V-K2,5-OE	
		PNP	–	3-pin	–	–	0.3	525 899	SMT-8F-PS-24V-K0,3-M8D
					NPN	–		–	525 910
		PNP	–	–	3-pin	0.3	525 900	SMT-8F-PS-24V-K0,3-M12	
	Insertable from end, flush with the cylinder profile	PNP	3-wire	–	–	2.5	175 436	SMT-8-PS-K-LED-24-B	
				–	3-pin		–	0.3	175 484

Ordering data – Proximity sensors for slot type 8, magnetic reed						Technical data → www.festo.com	
	Mounting	Electrical connection		Cable length [m]	Part No.	Type	
		Cable	Plug M8				
Normally open contact							
	Insertable from above	3-wire	–	2.5	525 895	SME-8F-DS-24V-K2,5-OE	
			–		5.0	525 897	SME-8F-DS-24V-K5,0-OE
		2-wire	–	2.5	525 907	SME-8F-ZS-24V-K2,5-OE	
		–	3-pin	0.3	525 896	SME-8F-DS-24V-K0,3-M8D	
	Insertable from end, flush with the cylinder profile	3-wire	–	2.5	150 855	SME-8-K-LED-24	
			–		3-pin	0.3	150 857
		–	–	–	–	–	–

Ordering data – Plug sockets						Technical data → www.festo.com	
	Mounting	Switch output		Connection	Cable length [m]	Part No.	Type
		PNP	NPN				
Straight socket							
	M8 locknut	■	■	3-pin	2.5	159 420	SIM-M8-3GD-2,5-PU
		■	■		5	159 421	SIM-M8-3GD-5-PU
Angled socket							
	M8 locknut	■	■	3-pin	2.5	159 422	SIM-M8-3WD-2,5-PU
		■	■		5	159 423	SIM-M8-3WD-5-PU

Core Range



100 % service for 100 % partnership

Welcome to the world of Festo service. Customer orientation is not just our everyday philosophy – it is our launch pad for the future and our route to success for both our customers and ourselves.

Global presence, always close at hand

- 52 independent subsidiaries worldwide in constant on-line communication
- A presence in almost 176 countries, with a total of 10,500 staff
- Worldwide networking for consistent standards of consultancy, sales and service

Personal advice worldwide

- Worldwide support provided by over 700 highly-qualified technical consultants
- 24-hour hotlines available in many sales offices

Software service

Electronic catalogue:

Database-supported general catalogue on CD-ROM in six languages and a wealth of advantages:

- Fast reliable product search functions
 - Automatic selection of accessories
 - Sizing of pneumatic circuits
 - Calculation and sizing programmes with direct links to search functions
- Take advantage of this genuine alternative to our printed catalogue.

Festo Design Tool – provides support for designers with 2D- and 3D drawings for CAD systems.

FluidDraw – allows fast and easy drafting of circuit diagrams, with direct import of data from the electronic catalogue.

Info service

- Full documentation with detailed technical information
- Attractive regular customer magazines showing useful application examples and new product information
- The latest information available via the Internet at the click of a mouse from <http://www.festo.com>

Everything from a single source

- Our catalogue includes over 16,400 products
- All our components are precisely coordinated
- Designed for maximum productivity and cost-effectiveness

- Drives and drive accessories
- Handling and vacuum technology
- Positioning
- Valves and valve accessories
- Valve terminals and bus systems
- Proportional technology
- Compressed air preparation
- Tubing, fittings, mounting accessories
- Sensors and pressure switches
- Pneumatic control technology
- Electronic control technology

Customer service

- Telephone advice via hotlines
- Fast on-site service
- Reliable maintenance and complaints service

Spare-parts service

- Short delivery distances thanks to worldwide local spare-parts service
- Supply from Festo fully stocked stores
- Prompt deliveries of Festo components
- For particularly urgent cases, Festo sales office holds stocks of a good range of almost all accessories and standard components

Delivery service

- Fast deliveries of catalogue products exstock
- Non-standard stroke and special-design cylinder production (SMS) in 25 countries
- Fully-automated Customer Service Center (production and logistics) in St. Ingbert-Rohrbach, Germany
- Very short throughput times
- International monitoring of local production by production managers from Rohrbach
- Customer Service Center handles over 7,400 orders comprising 16,000 items every day
- Daily movement of 6,500 crates weighing a total of 50,000 kg
- Direct deliveries to customers throughout Europe



©Copyright by Festo AG & Co.

Whilst every effort is made to ensure that all dimensions and specifications are correct, any printers' errors not rectified are outside the control of Festo, who cannot be held responsible for same. For Liability and Guarantee conditions, refer to our standard "Conditions of Sale", available on request from your local Festo office. All rights reserved, including translation rights. No part of this publication may be reproduced or transmitted in any form or by any means, electronic, mechanical, photocopying or otherwise, without the prior written permission of Festo AG & Co.

All technical data subject to change according to technical update.

Summary of further components

Important components in our product range

Compressed air preparation

- Service units D series



Control technology

- Individual valves type CPE
- Valve terminal type CPV
- Smart Positioning Controller type SPC200
- Front-End Controller IPC FEC Standard type FC640

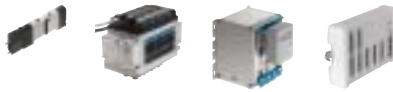

Long linear movement

- Rodless cylinder type DGPL
- Electric toothed-belt drive type DGE
- Standard cylinder type DNC and type DSNU



Short linear movement

- Linear module type HMP
- Guide unit type DFM
- Mini slide type SLT
- Flat slide type SLG
- Linear module type HMPL
- Short-stroke cylinder type ADVC



Rotary movement

- Rotary drive type DRQD
- Swivel module type DSM
- Swivel/linear module type DSL



Gripping, mechanical ...

- Precision gripper type HGPP
- Micro gripper type HGWM
- Three-point gripper type HGD



... or with vacuum

- Suction gripper type ESG
- Vacuum generator type VADMI
- Vacuum generator type VAD New Line



Connecting and installing

- Basic elements
- Screw connectors
- Restrictors
- Tubing



Parts sorting and testing

- Checkbox family



Further products and details: <http://catalog.festo.com> or consult your Festo technical advisor.



















A plea for precision

The evidence is clear: with the DGP/L rodless drive units, you can do both yourself and your

control system a favour. All arguments say precisely this.

	Advantages for design	Advantages for purchasing
1. High load rating, precision guide, minimized overall size and long service life	<ul style="list-style-type: none"> – Optimized stroke/construction length ratio – Reliable operation – Reduced downtimes 	<ul style="list-style-type: none"> – Favourable price/performance ratio – Low operating costs
2. Diverse range of DGP/L rodless drive units	<ul style="list-style-type: none"> – Reduced planning effort – Diverse applications – Electrical and servopneumatic axes in the same design 	<ul style="list-style-type: none"> – Reduced ordering effort – Saves effort when mounting – Long-life system – Fast delivery of the full range
3. Ease of servicing	<ul style="list-style-type: none"> – Planning tools simplify design – Convenient maintenance 	<ul style="list-style-type: none"> – No unnecessary costs due to oversized system – Worldwide spare parts service

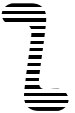
Pneumatic Pictograms

-  -	Stroke length	-  -	Service
-  -	Flow rate	-  -	Repair service
-  -	Voltage	-  -	Worldwide service
-  -	Force	-  -	Hotline
-  -	Pressure	-  -	Collection facility
-  -	Temperature range	-  -	Delivery time
-  -	Diameter	-  -	In stock
-  -	Vacuum	-  -	Important
-  -	Width	-  -	Type discontinued
		-  -	New
		-  -	Repairable