

Document Number: AFS-BH430-IBF-ICA

Revision: B

Date: 19 April 2011

---

---

## INSTRUCTIONS FOR CONTINUED AIRWORTHINESS

---

---

### INLET BARRIER FILTER SYSTEM

for the

**Bell Helicopter Textron Canada**

**Model 230 and 430 Helicopters**

**FAA STC No. SR02794CH**

---

---



**Donaldson**<sup>®</sup>  
FILTRATION SOLUTIONS  
**AFS | LE BOZEC | WESTERN FILTER**

17891 Chesterfield Airport Road  
Chesterfield, MO 63005

**COPYRIGHT© 2008**

**Aerospace Filtration Systems, Inc.**  
UNPUBLISHED — ALL RIGHTS RESERVED

***LIMITED and/or RESTRICTED RIGHTS NOTICE***

This document, along with its drawings and photographs, contains Trade Secrets and/or Commercial or Financial Information that is proprietary to Aerospace Filtration Systems, Inc. (AFS) under 5 USC 552 as amended, and is Prohibited from Public Disclosure by 18 USC 1905. Do not duplicate or disclose outside the U.S. Government without the express written permission of Aerospace Filtration Systems, Inc.

The Government's rights to use, modify, reproduce, release, perform, display, or disclose these technical data are restricted to the purpose of evaluating AFS's design for FAA commercial certification and airworthiness consideration only. Any reproduction of technical data or portions thereof marked with this legend, or referring to this legend, must also reproduce the markings and legend. Any person, other than the Government, who has been provided access to such data must promptly notify: Aerospace Filtration Systems, Inc., Attn: Business Manager, 17891 Chesterfield Airport Road, Chesterfield, MO 63005

The data subject to this limited/restricted rights notice is contained on all pages.

## PROPRIETARY DATA STATEMENT

This data, excluding Chapter 4, Airworthiness Limitations, are proprietary to Aerospace Filtration Systems, Inc. Disclosure, reproduction, or use of these data for any purpose other than helicopter operation and/or maintenance is forbidden without prior written authorization from Aerospace Filtration Systems, Inc.

## EFFECTIVITY

Effectivity for this ICA is for all Bell model 230 and 430 helicopters with the Aerospace Filtration Systems, Inc. (AFS) Inlet Barrier Filter (IBF) System installed.

### SIGNATURES

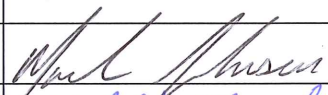
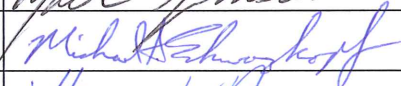
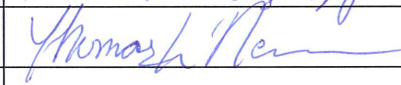
Revision		Name	Signature	Date
Initial Release	Prepared By:	Mark Johnson	Original Signed By	11-26-08
	Reviewed By:	Mike Schwarzkopf	Original Signed By	11-26-08
	Approved By:	Tom Newman	Original Signed By	11-26-08
A	Prepared By:	Mark Johnson	Original Signed By	8-24-09
	Reviewed By:	Mike Schwarzkopf	Original Signed By	8-24-09
	Approved By:	Tom Newman	Original Signed By	8-24-09
B	Prepared By:	Mark Johnson		4-19-11
	Reviewed By:	Mike Schwarzkopf		4-19-11
	Approved By:	Tom Newman		4-19-11

### LOG OF REVISIONS

Revision No.	Revision Description	Release Date
IR	Initial Release	11-26-08
A	Changed 106114-201 to 118265-201 and 104441-201 to 104441-203, associated with these changes are the tables in sections 8.5.2.5, 8.5.3.7, and Appendix A.	8-24-09
B	Added Bell 230 to applicability, changed logo and address on cover page.	4-19-11



# INSTRUCTIONS FOR CONTINUED AIRWORTHINESS

For the Aerospace Filtration Systems Engine Inlet Barrier Filter System  
Installed on the Bell Model 230 and 430 Helicopters

## Table of Contents

<b>1</b>	<b>INTRODUCTION.....</b>	<b>1</b>
1.1	SCOPE OF THIS MANUAL.....	1
1.2	USE OF THIS MANUAL.....	1
1.3	DEFINITIONS / TERMINOLOGY .....	1
1.4	ACRONYMS .....	3
1.5	WARNINGS, CAUTIONS, AND NOTES.....	4
1.6	UNITS OF MEASURE.....	4
1.7	REFERENCE PUBLICATIONS.....	4
1.8	LIST OF APPLICABLE PUBLICATIONS .....	4
1.9	DISTRIBUTION OF CHANGES.....	5
1.10	INDICATION OF CHANGES .....	5
1.11	SYSTEM DESCRIPTION AND OVERVIEW .....	5
<b>2</b>	<b>AIRWORTHINESS LIMITATIONS.....</b>	<b>8</b>
2.1	FAA APPROVAL BLOCK.....	8
2.2	GENERAL .....	9
2.3	FILTER RETIREMENT LIFE .....	9
2.4	LIFE LIMITED COMPONENTS.....	9
<b>3</b>	<b>INSPECTION REQUIREMENTS AND OVERHAUL.....</b>	<b>10</b>
3.1	INSPECTION REQUIREMENTS .....	10
3.2	GENERAL REQUIREMENTS .....	10
3.2.1	<i>FILTER ASSEMBLY INSPECTION</i> .....	10
3.2.2	<i>STRUCTURAL COMPONENT INSPECTIONS</i> .....	11
3.2.3	<i>SYSTEMS AND ELECTRICAL COMPONENT INSPECTIONS</i> .....	11
3.2.4	<i>IBF BYPASS COCKPIT SWITCH FUNCTION CHECK</i> .....	12
3.3	OVERHAUL REQUIREMENTS.....	12
<b>4</b>	<b>ACCESS PANELS .....</b>	<b>15</b>
4.1	GENERAL DESCRIPTION.....	15
4.2	ACCESS FOR FILTER SERVICING .....	15
4.3	ACCESS FOR MAINTENANCE .....	15
<b>5</b>	<b>STORAGE .....</b>	<b>16</b>
5.1	STORAGE.....	16
<b>6</b>	<b>PLACARDS, DATA PLATES, AND MARKINGS .....</b>	<b>17</b>
6.1	MARKING – PART NUMBER / PMA / SERIALIZATION .....	17
6.2	DATA PLATE – FILTER ASSEMBLY.....	17
6.3	PLACARDS / MARKINGS - COCKPIT .....	17
<b>7</b>	<b>SERVICING.....</b>	<b>18</b>
7.1	AUTHORIZED MATERIALS.....	18
7.2	FILTER SERVICE INTERVALS .....	18
7.2.1	<i>GENERAL REQUIREMENTS</i> .....	18
7.2.2	<i>PREPARED FIELD OPERATIONS</i> .....	19
7.2.3	<i>SEVERE ENVIRONMENT OPERATIONS</i> .....	19
7.3	FILTER ASSEMBLY SERVICING.....	20

7.3.1	FILTER PRE-CLEANING .....	20
7.3.2	FILTER CLEANING.....	20
7.3.3	FILTER DRYING .....	21
7.3.4	FILTER OILING.....	21
7.4	STRUCTURAL COMPONENT SERVICING .....	22
7.5	SYSTEMS AND ELECTRICAL SERVICING.....	23
7.6	ENGINE WATER WASH.....	23
7.7	AIRCRAFT WASHING.....	23
<b>8</b>	<b>TROUBLESHOOTING AND MAINTENANCE .....</b>	<b>24</b>
8.1	MAINTENANCE GENERAL .....	24
8.2	COMPONENTS - GENERAL DESCRIPTION.....	25
8.2.1	FILTER ASSY / FILTER SEAL.....	25
8.2.2	STRUCTURAL COMPONENTS .....	25
8.2.3	SYSTEMS AND ELECTRICAL COMPONENTS.....	25
8.3	FILTER ASSY / FILTER SEAL.....	26
8.3.1	FORWARD FILTER ASSY .....	26
8.3.2	UPPER FILTER ASSY.....	30
8.3.3	FILTER SEALS.....	31
8.4	STRUCTURAL COMPONENTS .....	33
8.4.1	BYPASS STRUCTURAL ASSY .....	33
8.5	SYSTEMS AND ELECTRICAL COMPONENTS .....	36
8.5.1	COCKPIT SWITCH/INDICATOR.....	36
8.5.2	DIFFERENTIAL PRESSURE SWITCH .....	37
8.5.3	FILTER MAINTENANCE AID .....	40
8.5.4	ACTUATOR.....	43
8.5.5	WIRING, WIRING HARNESS, CONNECTORS, BACKSHELLS, CIRCUIT BREAKER, RELAY.....	46
8.6	FASTENER LISTING.....	47
8.7	PROTECTIVE TREATMENT .....	47
8.8	TROUBLESHOOTING GUIDE .....	49
8.9	SPECIAL TOOLS / SPECIAL EQUIPMENT .....	50
8.9.1	CONSUMABLE MATERIALS, SUPPLIES, AND PROTECTIVE TREATMENT SPECIFICATIONS ..	50
<b>9</b>	<b>ICA APPENDIX A – ILLUSTRATED PARTS BREAKDOWN .....</b>	<b>A-1</b>

## Table of Pictures

Picture 1: FMA Operation .....	13
Picture 2: Cockpit Switch/Indicator .....	17
Picture 3: Circuit Breaker .....	17
Picture 4: Oiling Filter Media .....	22
Picture 5: Hand Seamer Used to Straighten or Crimp Pleats.....	28
Picture 6: Test Setup with Manometer.....	40

## Table of Tables

Table 1: Inspection Intervals.....	14
Table 2: Protective Treatment for Components.....	48
Table 3: Troubleshooting Guide .....	49
Table 4: Consumable Materials, Supplies and Protective Treatment Specifications .....	50

## Table of Figures

Figure 1: IBF System Installation .....	7
Figure 2: FMA Reset Location .....	13
Figure 3: Example of Filter Assembly Data Plate .....	17
Figure 4: Test Equipment Setup .....	39

THIS PAGE INTENTIONALLY LEFT BLANK



## 1 INTRODUCTION

### 1.1 SCOPE OF THIS MANUAL

These Instructions for Continued Airworthiness (ICA) provide the information required to do the maintenance and repair of the Aerospace Filtration Systems, Inc. (AFS) Inlet Barrier Filter (IBF) system installation on the Bell Model 230 and 430 helicopters. The ICA should be used in conjunction with all pertinent Bell 230 and 430 manuals and all publications listed in the List of Applicable Publications (LOAP).

#### NOTE

**Thoroughly review and become familiar with the Appendix A – Illustrated Parts Breakdown section of this ICA before performing maintenance on the IBF system.**

### 1.2 USE OF THIS MANUAL

The instructions that are given in this manual and those that have been changed by revisions, bulletins and/or alerts issued by AFS, Bell or the Airworthiness Directives issued by the local Aviation Authority, shall be strictly followed.

### 1.3 DEFINITIONS / TERMINOLOGY

Actuator	An electromechanical actuator used to open / close the bypass door.
Air induction screen	Screen installed in the engine inlet on baseline configuration aircraft in lieu of the Particle Separator or the IBF, to prevent engine foreign object damage.
Air induction cowling	This cowling houses the major kit components including the IBF filter assembly, adaptor frame, bypass door assembly and associated wiring.
Brownout	A brownout condition is a zero visibility condition usually caused by hovering in a dusty environment.
Bypass	The bypass is an alternate air inlet used only when the main engine air inlet through the filter becomes clogged or blocked.
Bypass door	Door is located inboard of the filters that when opened by the actuator allows unfiltered air to be drawn into the engine.

Cockpit switch/indicator	<p>A push button switch, labeled “IBF 1” or “IBF 2”, is used to OPEN or CLOSE the respective bypass door. This switch is normally CLOSED and is pressed to the OPEN position only when the cockpit indicator, an amber caution “FILTER” light in the switch, illuminates.</p> <p>The “FILTER” portion of the switch illuminates any time the differential pressure reaches or exceeds a preset value.</p> <p>The “BYPASS” portion of the switch illuminates when the bypass door is completely open.</p>
Differential pressure	<p>Drop in pressure across the filter assembly, which is measured by the differential pressure switch and the filter maintenance aid.</p>
Delta P switch	<p>Differential pressure switch.</p>
Filter	<p>Barrier type filter media made of multi-layers of cotton gauze saturated with specially formulated oil that forms a tack barrier that increases the capture efficiency of the filter.</p>
Filter assembly	<p>Filter media supported by pleated stainless steel screen on both sides and the filter assembly frame components around the perimeter of the filter media.</p>
Filter assembly frame	<p>Structure that frames, retains, and seals the outside edges of the filter media.</p>
Filter downstream side	<p>Clean side of the filter media (i.e. the side of the filter facing engine inlet).</p>
Filter media	<p>A wet media consisting of multi-layered cotton gauze saturated with specially formulated oil.</p>
Filter pleats	<p>Stainless steel screen is used to form the pleats and hold the filter media in place.</p>
Filter upstream side	<p>Dirty side of the filter media (i.e. the side facing into the air stream on which the dirt collects).</p>
Inches of water	<p>Unit of measure used for the differential pressure measured across the filter, as measured with a water manometer or similar apparatus.</p>
Oiling	<p>Process used to apply a uniform amount of oil on filter media.</p>
On-condition	<p>Indicates that servicing of the filter is based on a Filter Maintenance Aid (FMA) indication in the area marked in “RED”, Power Assurance Check (PAC) results (where a failed PAC is the result of</p>

a dirty Filter Assembly), and / or any “IBF FILTER” light indication on the cockpit indicator.

Plenum chamber                      Space between the filter assemblies and the engine inlet, and the space between the Bypass Door and engine inlet.

Service cycle                        Period starting when a filter is cleaned, oiled and placed into service and ending when the filter is removed for its next cleaning and oiling.

## 1.4 ACRONYMS

AFS        = Aerospace Filtration Systems, Inc.  
FAR        = Federal Aviation Regulation  
FMA        = Filter Maintenance Aid  
FMS        = Flight Manual Supplement  
FOD        = Foreign Object Damage  
IBF        = Inlet Barrier Filter  
ICA        = Instructions for Continued Airworthiness  
IP         = Installation Procedures  
IPB        = Illustrated Parts Breakdown  
LOAP      = List of Applicable Publications  
OAT        = Outside Air Temperature  
PAC        = Power Assurance Check  
RFM        = Rotorcraft Flight Manual  
SAE        = Society of Automotive Engineers  
TCDS      = Type Certificate Data Sheet  
TIS        = Time in Service

## 1.5 WARNINGS, CAUTIONS, AND NOTES

Warning, cautions and notes are used throughout this manual to emphasize important and critical instructions.

### **WARNING**

**IF YOU DO NOT FOLLOW THE INSTRUCTIONS THAT ARE GIVEN IN A WARNING, PERSONAL INJURY CAN OCCUR.**

### **CAUTION**

**IF YOU DO NOT FOLLOW THE INSTRUCTIONS THAT ARE GIVEN IN A CAUTION, YOU CAN CAUSE DAMAGE TO THE HELICOPTER OR TO THE COMPONENTS.**

### **NOTE**

**A note includes supplemental data about the procedure, the practice, the condition, etc for the maintenance task.**

## 1.6 UNITS OF MEASURE

U.S. Standard units of measure have been used in preparation of this manual. Typical units used in this manual include: inches of water measuring differential pressure, inch-pounds of torque, etc.

## 1.7 REFERENCE PUBLICATIONS

Reserved for future use.

## 1.8 LIST OF APPLICABLE PUBLICATIONS

### Bell Helicopter

Model 430 Technical Publications

Model 230 Technical Publications

### FAA

FAA Advisory Circular, AC 43.13-1B, Acceptable Methods, Techniques, and Practices – Aircraft Inspection and Repair

## 1.9 DISTRIBUTION OF CHANGES

Changes shall be distributed by posting them on the AFS webpage [www.afsfilters.com](http://www.afsfilters.com).

### NOTE

**This webpage should be checked prior to the performance of any maintenance actions on the IBF system to confirm possession of the latest FAA approved revision. If access to the internet is not possible, contact AFS at (636) 300-5200 for assistance.**

## 1.10 INDICATION OF CHANGES

All changes will be complete revisions with all pages marked with the latest revision letter. All changes since the last revision shall be marked with a black vertical bar in the left side of the page.

## 1.11 SYSTEM DESCRIPTION AND OVERVIEW

- a. The Bell 230 and 430 IBF provides a barrier type filter assembly that mounts to the top of the Engine Air Induction Cowling in the same location and in lieu of the Air Induction Screen. The IBF installation requires only minor modifications to the existing Air Induction Cowlings and Forward Firewall. The IBF provides aircraft owner/operators a high performance engine air filtration option that provide excellent filtration efficiency. The IBF will increase the life of the engine through a dramatic reduction in erosion resulting from the substantial increase in filtration efficiency without degrading engine performance. The AFS IBF system provides dust separation efficiencies exceeding 99% for Society of Automotive Engineers (SAE) AC Coarse and AC Fine dust as defined in specification SAE J726, Air Cleaner Test Code.
- b. The IBF system does not interfere with any of the commercial items installed in the Bell 230 and 430 production aircraft. The IBF is a complete system in which safety, functionality and serviceability were major considerations in the design process. The major kit components include four filter assemblies, two cockpit switch/indicators, one structural assembly (which includes the bypass door assembly, actuator, differential pressure switch, filter maintenance aid and wiring harness) for each side. Figure 1, located at the end of this chapter, provides an exploded view of the major kit components with the exception of the cockpit switch, indicator light and aircraft wiring. For a detailed illustration of all kit components, see the Appendix A – Illustrated Parts Breakdown.
- c. The major components making up the bypass system include the bypass door, actuator, wiring harness, cockpit switch, indicator light, and differential pressure switch.
- d. The IBF system provides a means of monitoring the condition of the filters both in-flight and on the ground, and a bypass capability should flow through the filters become restricted. In-flight, when the differential pressure reaches the preset value the cockpit indicator light illuminates alerting the pilot that the filters are becoming restricted causing the engines to operate less efficiently. At this point, the IBF is operating at approximately the same inlet differential

pressure normally experienced with the Particle Separator installed. Upon illumination of the IBF “FILTER” caution light, the pilot must closely monitor the engine instruments and if engine performance degradation is evident the pilot should push the cockpit switch, labeled IBF 1 or IBF 2, to activate the actuator and open the bypass door for the respective engine. This will cause the upper segment of the switch, labeled “FILTER”, to extinguish and the lower segment of the switch, labeled “BYPASS”, to illuminate. The electromechanically actuated bypass door permits unfiltered air to enter the engine inlet plenum chamber should the filter media become obstructed, and can be opened or closed as required (See Picture 2).

On the ground, a Filter Maintenance Aid is mounted to the L/H and R/H Plenum Assy, which can be viewed by opening the inspection door on the Air Intake Cowling, displays the maximum differential pressure across the filter reached during the last flight. It is accessible only on the ground, providing the pilot or mechanic the ability to visually gauge the current condition of the filter. This gives the mechanic the ability to forecast the timing of the next service cycle. The Filter Maintenance Aid can be reset by depressing the yellow button marked “PUSH TO RESET” located on the end of the Filter Maintenance Aid (See Picture 1).

- e. The design of the bypass system allows the ground crew to cycle the bypass door with power on the aircraft. The switch can be pushed to actuate the bypass door open, and then pushed again to actuate it closed. Full functional verification of the bypass system including all electromechanical components and the filter maintenance aid is possible during routine maintenance (see Chapter 8).
- f. Removal of the filter assemblies for servicing is achieved by removal of sixteen (16) bolts after the Air Inlet Cowl and Plenum Assy have been removed.
- g. The engine wash can be accomplished with the IBF installed, in the same manner prior to installing the IBF system.

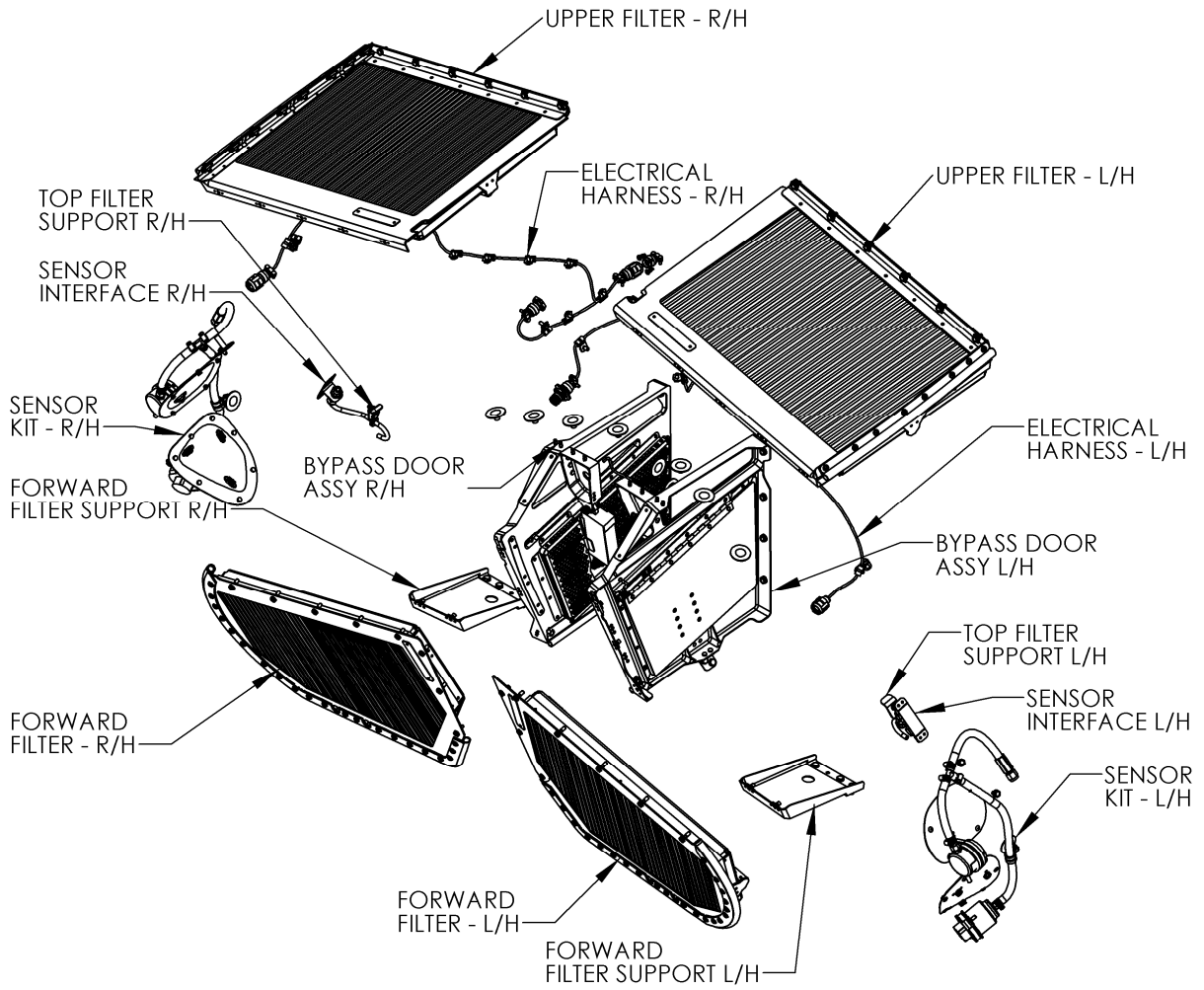

**Figure 1: IBF System Installation**





## 2.2 GENERAL

The Airworthiness Limitations for the AFS Inlet Barrier Filtration system (IBF) as installed on Bell Helicopter model 230 and 430 helicopters are FAA approved.

### NOTE

**The retirement life given or the failure to give a retirement life to a component does not constitute a warranty of any kind. The only warranty applicable to any component is the warranty included in the Purchase Agreement for the helicopter or the component.**

## 2.3 FILTER RETIREMENT LIFE

After fifteen (15) cleaning and oiling cycles, the filter must be removed from service at the next servicing interval. The filter data tag is scribed after each cleaning and oiling cycle (see Section 6-2). When all numerals (1-15) on the data tag have been scribed out, the filter shall be removed from service at the next service interval. No further cleaning cycles are authorized.

## 2.4 LIFE LIMITED COMPONENTS

The only life limited component features are the number of cleanings of the filter assembly. See Section 2.3.

### 3 INSPECTION REQUIREMENTS AND OVERHAUL

#### 3.1 INSPECTION REQUIREMENTS

#### 3.2 GENERAL REQUIREMENTS

- a. Inspection of the IBF system consists of, in general terms, inspection of the filter assembly, inspection of the structural components, inspection of electrical and system components, and a special inspection at three specified points based on hours after initial installation. The components of the system are divided, generally as a scope of work, into Filter Assembly, Seal, Structural Components, and Systems and Electrical components as is done throughout the manual.
- b. Refer to Appendix A - Illustrated Parts Breakdown for component illustrations that provide supplemental information relative to proper assembly configuration, orientation, and locations for all components to be inspected per Chapter 3 and Table 1. Refer to Appendix A, Figure A-1 for the primary kit components. Refer to Figures A-2 through A-9 for structural details. Refer to Figure A-12 for electrical components.
- c. Table 1 gives a recommended inspection schedule for the components of the system. The Trouble-Shooting Guide, Table 3 found near the end of Chapter 8, also gives additional guidance when performing inspections and encountering trouble with the system. Chapter 8 also provides specific inspection guidance and removal/installation procedures for each component and is structured in the same three major groups as discussed above.

##### 3.2.1 FILTER ASSEMBLY INSPECTION

- a. The following inspections pertain to the barrier filter assembly and associated components, which include the filter assembly (i.e. filter frame and filter media) and all associated seals/fasteners.
- b. ON-CONDITION: Any FMA indication in the “RED”, “FILTER” light indication of the IBF cockpit indicator or failed PAC requires a visual inspection in accordance with Chapter 8.
- c. VISUAL: All filter assembly components are to be visually inspected at every annual inspection in accordance with Table 1 checking for the following: filter media for tears, punctures, uneven or damaged pleats; seals for tears/damage; frame components for corrosion, cracks, distortions near holes, and check for missing or damaged fasteners.

### 3.2.2 STRUCTURAL COMPONENT INSPECTIONS

**VISUAL**: All structural IBF components are to be inspected in accordance with Table 1 every 100 hours and annual inspection. These components include the following: Forward Filter Assemblies, Upper Filter Assemblies, Side Closeout Assemblies, and Sensor mounting components.

### 3.2.3 SYSTEMS AND ELECTRICAL COMPONENT INSPECTIONS

- a. **VISUAL**: The systems and electrical components are to be visually inspected in accordance with Table 1 every 100 hours and annual inspection. These components include the following: Wiring, Wiring Harnesses, Connectors, Backshells, Circuit Breakers, Cockpit Switch/Indicators, Differential Pressure Switches, Filter Maintenance Aids, and Actuators.
- b. **FUNCTION CHECK**: Certain systems and electrical components are also to be function checked in accordance with Table 1 every annual inspection. These components include the following: Circuit Breakers, Cockpit Switch/Indicators, Differential Pressure Switches, Filter Maintenance Aids, and Actuators.
- c. **FMA CHECK**: The FMA check is performed to ascertain the current condition of the filter or to gage the trend in accumulation of dirt. The FMA check is only a check of the indicator reading (See Picture 1). As such it is not considered an inspection of the FMA. The inspection Table 1 does not require a specific “inspection” interval of the FMA. The condition of the Filter Assembly and its accumulation of dirt will show up as an indication on the FMA. Thus operational environment, more so than time in service, dictate how often the FMA should be checked in order to help determine the next Filter Assembly service requirement. It is an aid in scheduling the Filter Assembly servicing. At any time prior to an FMA indication in the “RED” (See Picture 1), a failed PAC, or a IBF “FILTER” indication on the cockpit indicator, when maintenance or flight personnel see a trend based on the FMA readings over time that would warrant servicing of the filter due to operational considerations, such as when the aircraft will be operated in a remote or off-site location without the ability to readily service the filter, the filter may be serviced, or replaced. See Section 7.2 for a further description of the use of the FMA as it relates to the Filter Assembly service interval. See filter servicing Section 7.3.

#### NOTE

**The Filter Maintenance Aid is designed to hold the highest differential pressure measured across the filter assembly during the last flight, and should be reset after servicing of the filter assembly by depressing the yellow button marked “PUSH TO RESET” located on the end of the filter maintenance aid (See Picture 1).**

### **3.2.4 IBF BYPASS COCKPIT SWITCH FUNCTION CHECK**

**FUNCTION CHECK:** A function check of each IBF BYPASS Cockpit Switch is to be performed every 100 hours (See Table 1). Perform the function check as follows: (1) With aircraft power ON, push the IBF BYPASS switch in, the BYPASS light should illuminate and the bypass door should open, visually verify this has happened. (2) Push the IBF BYPASS switch in, and the BYPASS light should go out and the bypass door should close, visually verify this has happened. Turn aircraft power OFF. If conditions are not met refer to Table 3 Troubleshooting Guide.

### **3.3 OVERHAUL REQUIREMENTS**

There are no overhaul intervals or requirements applicable to this product at this time.

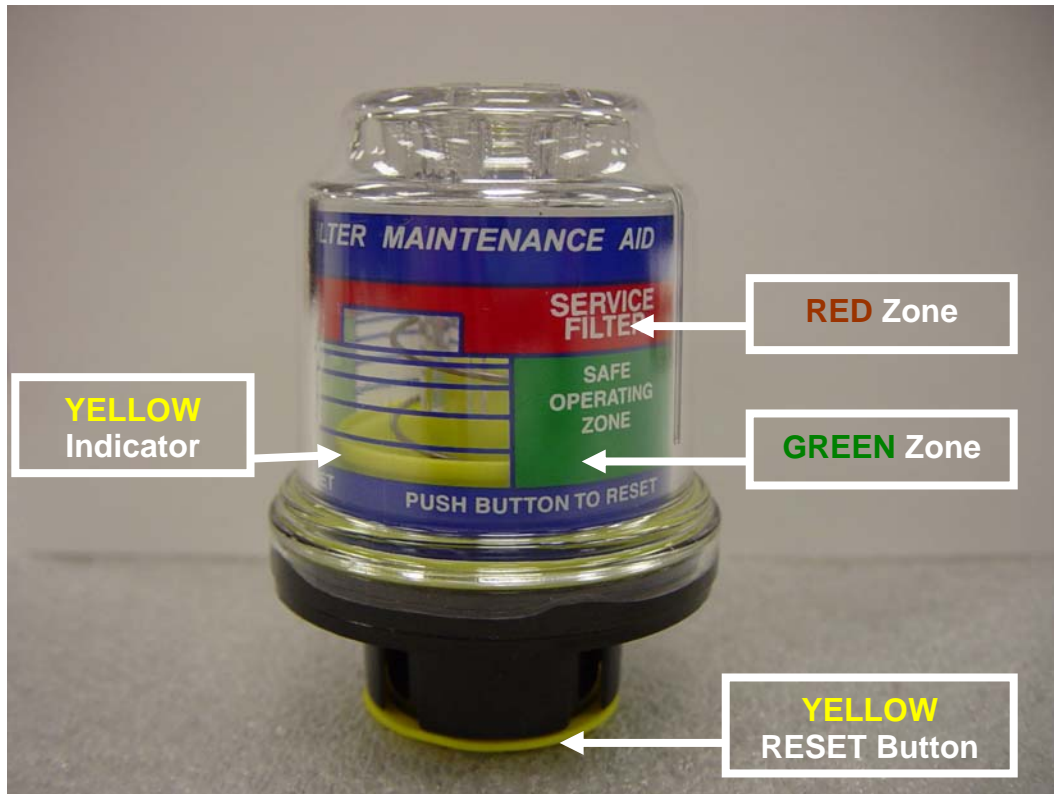

**Picture 1: FMA Operation**

“YELLOW Indicator” position relative to SAFE OPERATING ZONE (“GREEN Zone”) or SERVICE FILTER (“RED Zone”) markings defines current filter condition, and pushing “YELLOW RESET Button” resets indicator.

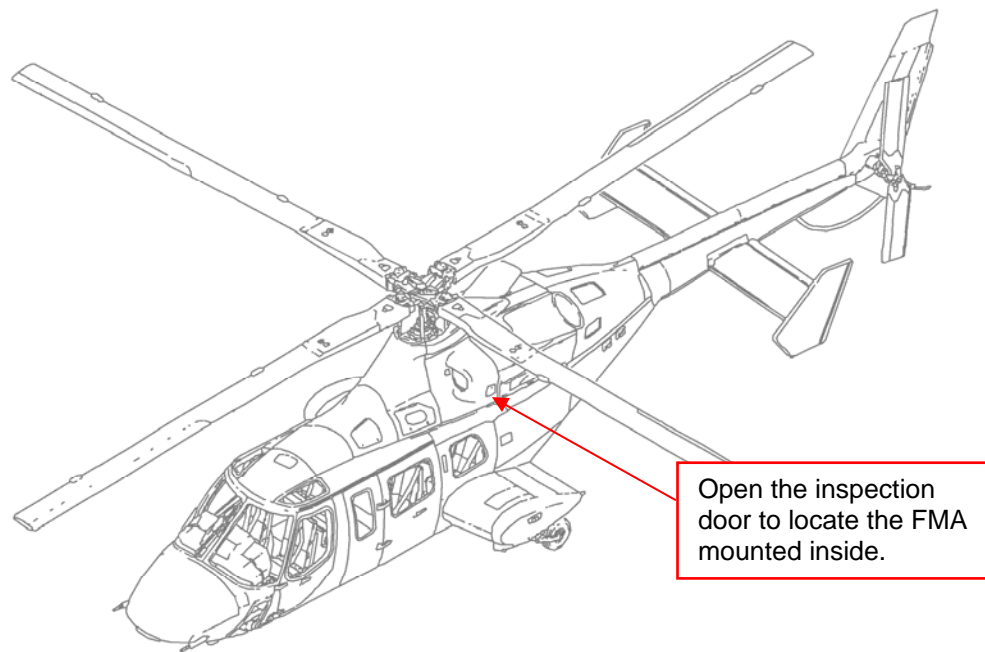

**Figure 2: FMA Reset Location**

**Table 1: Inspection Intervals**

Components	Inspection Type	Inspection	Inspection Intervals			
			Scheduled		Time In Service	Notes
			100 Hrs.	Annual		
Filter Assembly as defined in para. 3.2.1.	Conditional	1. Visual			300 hrs / 1 yr	2, 3, 4, 5, 7
	Scheduled	2. Visual		X		1, 2, 4, 6, 7
Structural Components as defined in para. 3.2.2.	Scheduled	1. Visual	X	X		1, 2, 4, 6
Systems and Electrical Components as defined in para. 3.2.3.	Scheduled	1. Visual	X	X		1, 2, 4, 6
	Scheduled	2. Function Check		X		1, 2, 4, 5
IBF Bypass Cockpit Switch as defined in para. 3.2.4.	Scheduled	1. Function Check	X			8

**NOTES:**

1. Refer to Chapter 8 for specific inspection requirements and functional check procedures.
2. Refer to Chapter 4 for access information.
3. IBF FILTER light or failed PAC. This inspection is required any time an IBF FILTER light indication or failed PAC is reported by the pilot.
4. Reference Appendix A – Illustrated Parts Breakdown.
5. Reference Trouble-Shooting Guide, Table 3 of this manual.
6. Perform a visual inspection checking for deformation, buckling, corrosion, cracks, dents, tears, or other signs of damage and repair in accordance with the procedures in Chapter 8.
7. The maximum filter service interval between cleanings under any conditions is 300 flight hours or 1 year TIS, whichever comes first. Up to the TIS limit, the inspection of the Filter Assembly is “On-Condition” based on an FMA indication in the “RED”, any “IBF FILTER” light indication on the Cockpit Indicator, and / or upon a failed PAC (where the failed PAC is the result of a dirty Filter Assembly).
8. If conditions are not met refer to the Table 3 Troubleshooting Guide in this manual.

## **4 ACCESS PANELS**

### **4.1 GENERAL DESCRIPTION**

This chapter addresses how to access the IBF system installation for servicing or maintenance.

### **4.2 ACCESS FOR FILTER SERVICING**

Filter servicing requires removal of the L/H and R/H Air Inlet Cowl and the L/H and R/H Air Intake Plenum to gain access to the filter assemblies. The filter assemblies must be removed for servicing. See Chapter 8 for filter assembly removal/installation procedures and Chapter 7 for filter servicing procedures.

### **4.3 ACCESS FOR MAINTENANCE**

Access for maintenance of the system components requires removal of the L/H and R/H Air Inlet Cowl, the L/H and R/H Air Intake Plenum and the filter assemblies. See Chapter 8 for component removal/installation procedures, inspection, troubleshooting guide, adjustment/calibration/repair procedures.

## 5 STORAGE

### 5.1 STORAGE

#### CAUTION

**NEVER INSTALL A FILTER ASSEMBLY AND/OR OPERATE AN AIRCRAFT WITH A FILTER INSTALLED WHERE THE FILTER MEDIA HAS NOT BEEN PROPERLY OILED.**

Long-term storage has no effect on filter assembly reliability if stored unoiled (dry) in a cool, dry location to discourage possible fungus growth. After storage, the only maintenance to be performed on the filter before installation on the aircraft is oiling of the filter media. Refer to filter servicing Section 7.3.



## 6 PLACARDS, DATA PLATES, AND MARKINGS

### 6.1 MARKING – Part Number / PMA / Serialization

The IBF system is marked on the floor assembly to contain the top level part number, the serial number of the system, and the FAA PMA markings, if applicable.

### 6.2 DATA PLATE – FILTER ASSEMBLY

After the filter assembly has been serviced an “X” is marked through one of the unmarked boxes on the serviceability tag (see Figure 3). When the last unmarked box is crossed through, the filter assembly will have to be replaced at the next servicing. See Chapter 7 for servicing procedures.

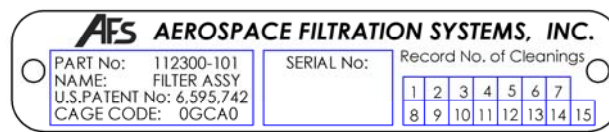

Figure 3: Example of Filter Assembly Data Plate

### 6.3 PLACARDS / MARKINGS - COCKPIT

- The IBF utilizes two cockpit switch/indicators labeled “IBF 1” and “IBF 2” on the aircraft instrument panel. The upper segment illuminates an amber “FILTER” message when the IBF differential pressure has reached a preset value. The lower segment illuminates an amber “BYPASS” message when the actuator has been energized and the bypass door is open. See Picture 2 for markings.
- The IBF circuit breakers in the overhead console are marked “IBF 1 / IBF 2”. See Picture 3 for markings.



Picture 2: Cockpit Switch/Indicator



Picture 3: Circuit Breaker

## 7 SERVICING

### 7.1 AUTHORIZED MATERIALS

Service AFS Filter Assemblies with only AFS approved filter oil or AFS authorized substitutes.

#### NOTE

**Refer to Chapter 8 for removal, inspection, repair and installation of filter assembly. Upon satisfactory inspection and any required maintenance of the filter assembly proceed with the rest of the servicing instructions for the filter assembly.**

### 7.2 FILTER SERVICE INTERVALS

The filter service interval is based on the specific aircraft operating environment. The filter service intervals section is broken up in three parts: general requirements pertaining to all operations, specific recommendations for operations on prepared fields, and for operations in severe environments.

#### 7.2.1 GENERAL REQUIREMENTS

#### NOTE

**The maximum filter service interval between cleanings under any conditions is 300 flight hours or 1 year TIS, whichever comes first. Up to the TIS limit, the filter is considered an “on-condition” item. For consistent performance AFS recommends that all Filter Assemblies be serviced at the same time.**

#### NOTE

**The FMA is an aid to help maintenance personnel and pilots to ascertain the condition of the filter at any point in time or to trend the accumulation of dirt on the Filter Assembly over a period of time.**

- a. Up to the 300 hour / 1 year TIS limit, the “on condition” requirement for servicing the Filter Assembly is based on a FMA indication, an IBF “FILTER” light indication on the cockpit indicator or upon a failed PAC (where the failed PAC is the result of a dirty Filter Assembly).
- b. Any IBF “FILTER” indication, where the pressure sensor and indicating system are working properly, requires servicing of the filter assembly. See filter servicing Section 7.3.
- c. The gradual increase in differential pressure across the IBF filter assembly causes an increase in MGT required to produce a specified torque as measured during the PAC. A failed PAC due to an increase in differential pressure across the filter is cause for servicing of the filter assembly. See filter servicing Section 7.3.

- d. Any FMA indication in the area marked in “RED” requires servicing of the filter assembly. See filter servicing Section 7.3.
- e. At any time prior to an IBF “FILTER” indication on the cockpit indicator, an FMA indication in the “RED”, or a failed PAC, when maintenance or flight personnel see a trend on the FMA that would warrant servicing of the filter due to operational considerations, such as when the aircraft will be operating in a remote or off-site location without the ability to readily service the filter, the filter may be serviced, or replaced. See filter servicing Section 7.3.
- f. The maximum number of service cycles for the filter assembly (i.e., cleaning / oiling) is limited to 15 for each filter assembly. The filter assembly includes a data plate that must be scribed to track filter service cycles in accordance with Section 6.2.

### **7.2.2 PREPARED FIELD OPERATIONS**

- a. During typical operations in and out of prepared airfields and landing sites, the IBF filter assembly will not require frequent servicing. AFS recommends that the filter maintenance aid (FMA) be checked about every 25 aircraft operating hours following the first installation and operation of an IBF system on an aircraft. This should be done to gauge the rate of engine performance degradation due to changes in engine inlet differential pressure as the filters accumulate dirt in operations considered “prepared fields” operations. Once an interval of time in flight hours is determined that provide discrete changes in the FMA, this interval can be repeated as long as there is no change in the environmental operating conditions.
- b. This interval can be extended after sufficient flight data has been accumulated to establish a greater interval. Upon seeing increases in MGT and associated decreases in temperature margin / available power, the inspection interval should again be shortened to about every 25 hours or less to enable scheduling of filter servicing without interruption of normal operations.
- c. Ensure all filter servicing requirements defined in Section 7.2.1 are followed. Refer to Section 7.3 for servicing of the filter assembly.

### **7.2.3 SEVERE ENVIRONMENT OPERATIONS**

- a. When operating in an environment of high sand and dust levels, frequent servicing of the filter assembly may be required based on the time exposure and severity of the environment. Any operations in an environment that can result in “brownout” conditions should therefore be minimized or avoided to the maximum extent possible within the constraints of the operation. During operations for extended periods of time in brownout conditions, monitoring of the FMA between shut down and start up will allow the maintainer or operator to trend the change in differential pressure. Once an interval of time in flight hours is determined that provide discrete changes in the FMA, this interval can be repeated as long as the initial readings remain typical of the current operations.
- b. Ensure all filter servicing requirements defined in Section 7.2.1 are followed. Refer to Section 7.3 for servicing of the filter assembly.

## 7.3 FILTER ASSEMBLY SERVICING

The filter assembly servicing section defines the procedures for pre-cleaning, cleaning, drying, and oiling the filter media in the filter assembly.

### 7.3.1 FILTER PRE-CLEANING

- a. Servicing of the filter assembly is determined by the inspection requirements found in Chapter 3.
- b. Prior to any cleaning operation gently brush the dirty side of the filter with a soft bristle brush similar to a soft paintbrush. Remove as much debris as practical from the filter before proceeding to the cleaning procedure.

### 7.3.2 FILTER CLEANING

#### CAUTION

**DO NOT CLEAN AFS FILTER ASSEMBLIES WITH GASOLINE, SOLVENTS, PARTS CLEANERS, STRONG DETERGENTS, OR CAUSTIC CLEANING SOLUTIONS.**

#### CAUTION

**DO NOT STEAM CLEAN OR USE HIGH-PRESSURE WASHERS TO CLEAN THE AFS FILTER ASSEMBLY.**

#### CAUTION

**ANY OF THESE PROCESSES WILL DAMAGE THE FILTER MEDIA AND/OR THE FILTER FRAMES.**

- a. Spray AFS approved Air Filter Cleaner liberally onto the entire filter media (both sides) until the filter media is thoroughly soaked. If procured in bulk, transfer a smaller quantity to a spray bottle. A spray bottle provides a more uniform distribution of the cleaning agent.
- b. Let the cleaner soak into the contaminants and filter media for 10 minutes.
- c. Rinse the filter with low-pressure water. Use water out of a faucet or hose (without nozzle). Rinse in the opposite direction of airflow, i.e., from the clean side to the dirty side. Arrange the filter so the pleats are vertical, and begin to rinse in a gradual side-to-side motion starting at the top and working downward. Adjust the pace to correspond with the cleanliness of the water runoff. As long as the runoff is filled with debris and oil, do not proceed downward.
- d. Upon completion, adjust the filter to rinse from the dirty side to the clean side, pleats still vertical.

- e. Repeat the rinsing procedure once again, until there is no visible debris on the surface and the runoff water is relatively clean.
- f. When finished, flip the filter once again and repeat the rinse from clean side to dirty side.
- g. Finally, rotate the filter from top to bottom, and perform the final rinse until the runoff water is free of all debris and oil.

### 7.3.3 FILTER DRYING

#### CAUTION

**DO NOT USE COMPRESSED AIR TO DRY THE FILTER ASSEMBLY. IT MAY DAMAGE THE FILTER MEDIA.**

#### CAUTION

**DO NOT USE HEAT FROM ANY SOURCE TO DRY THE AFS FILTER ASSEMBLY. HEAT MAY SHRINK THE FILTER MEDIA AND MAY DAMAGE THE CORING MATERIAL WITHIN THE FILTER FRAMES.**

- a. After rinsing, shake off the excess water and let the Filter Assembly dry at room or outside air temperature (above freezing).
- b. Ensure dirt or debris does not enter or contact the Filter Assembly while drying.
- c. After the Filter Assembly dries, mark the service cycle on the data plate in accordance with Section 6.2.

### 7.3.4 FILTER OILING

#### CAUTION

**NEVER PUT AN AFS FILTER ASSEMBLY IN SERVICE WITHOUT OILING IT.**

#### CAUTION

**USE ONLY AN AFS APPROVED OIL**

#### NOTE

**A squeeze bottle capable of accurately measuring out 6.5 and 9 fluid ounces should be used when applying the oil to the filter assembly as directed below.**

- a. The filter will not function properly if other types of oil are used. AFS approved Air Filter Oil is a unique blend of mineral and organic oil base stocks and special polymers that form a very efficient “tack barrier.” Red dye is added to show areas of oil application. Do not use transmission fluid, any kind of motor oil, or diesel fuel to oil the AFS filter. Do not use “WD-40,” “LPS,” or any other type of lightweight spray lubricants to oil the AFS filter. Any of those products will damage the filter or degrade its filtering ability. A squeeze bottle allows for the controlled application of a specific amount of oil to the filter (See Picture 4).
- b. Apply approximately ¾ of the 6.5 or 9 fluid ounces, (6.5 oz on the forward filter and 9 oz on the upper filter) that is to be applied to a clean, dried Filter Assembly. Gently squeeze a small stream of oil along the entire length of each pleat peak, then flip the filter over and repeat this on the backside. Apply sparingly to ensure coverage of the entire filter.

Filter	Part Number	Volume of Oil
Upper	118300-101	9.0 fl. Oz.
Front	118350-101	6.5 fl. Oz.

- c. Let the Filter Assembly sit for 20 minutes as the oil “wicks” into the surrounding filter media. Apply the remaining filter oil to any areas that are still white. Apply all of the oil in the bottle to the filter being serviced.



**Picture 4: Oiling Filter Media**

## 7.4 STRUCTURAL COMPONENT SERVICING

There are no structural components requiring periodic servicing. See Chapter 6 for inspection requirements and Chapter 8 for maintenance requirements.

## 7.5 SYSTEMS AND ELECTRICAL SERVICING

There are no system and electrical components requiring periodic servicing. See Chapter 6 for inspection requirements and Chapter 8 for maintenance requirements.

### NOTE

**The Filter Maintenance Aid is designed to indicate the highest differential pressure across the filter assembly reached during the last flight, and should be reset after servicing of the filter assembly by depressing the yellow button marked “PUSH TO RESET” located on the end of the filter maintenance aid (See Picture 1 & Figure 2).**

## 7.6 ENGINE WATER WASH

### NOTE

**It is not necessary to remove the IBF filter prior to conducting an engine wash.**

It is recommended the engine water wash frequency be in accordance with the current engine manufacturer requirements for operation in a standard environment, desert environment or salt-water environment.

## 7.7 AIRCRAFT WASHING

During aircraft washing, the IBF system including the filter assemblies should be protected to avoid damaging the filter media with high pressure spray nozzles or to prevent solvents from rinsing away the oil in the filter media.

## 8 TROUBLESHOOTING AND MAINTENANCE

### 8.1 MAINTENANCE GENERAL

#### CAUTION

**THOROUGHLY REVIEW AND BECOME FAMILIAR WITH THE APPENDIX A - PARTS FIGURES BEFORE PERFORMING MAINTENANCE ON THE IBF SYSTEM.**

#### NOTE

**Except where otherwise indicated, all torque values shall be in accordance with Chapter 7 of FAA Advisory Circular AC 43.13-1B.**

- a. The components of the system are divided, generally as a scope of work, into Filter Assembly / Seal, Structural Components, and Systems/Electrical components throughout the manual. Refer to Appendix A for a breakdown of the kit components. The troubleshooting guide in Table 3 provides additional guidance for performing inspections when encountering trouble with the system.
- b. The maintenance chapter is organized by removal, inspection, troubleshooting, adjustment, calibration and / or repair, and installation for the major components noted above, as applicable to the particular component. For some components a functional check is included. Not all components will require adjustment, or calibration, or have any approved functional check or repair procedures. Contact AFS for possible repairs when not listed in this manual. In some cases defective components will require replacement.
- c. In general, visually inspect all structural components for oversized or elongated holes, deformation, cracks, corrosion, missing fasteners or components, fretting, galling, etc. Any component exhibiting these conditions requires repair or replacement.
- d. In general, visually inspect fasteners for damaged or missing threads, in both the bolt or screw and the nut or nut plate. If a self-locking fastener can be fully threaded by hand, replace the self-locking fastener.
- e. In general, visually inspect all electrical connections for security, corrosion, arcing, breakdown of insulation, and overheating. Repair or replace components exhibiting defects. Inspect and repair components per Bell technical manuals or AC 43.13-1, Chapter 11.



## 8.2 COMPONENTS - GENERAL DESCRIPTION

### 8.2.1 FILTER ASSY / FILTER SEAL

(Refer to Appendix A, Figure A-10 & 11)

- a. Filter Assembly - The Filter Assembly is composed of the filter media (stainless steel mesh covering cotton gauze) bonded into the aluminum alloy filter frame assembly.
- b. Filter Seals – The Upper Filter has a silicon sponge that is held in place with adhesive and a P-seal that is held on with a retainer and bolts. The Forward Filter has a P-seal that is held on with a retainer and bolts.

### 8.2.2 STRUCTURAL COMPONENTS

(Refer to Appendix A, Figure A-1)

- a. Bell Forward Firewall (OEM Equipment) - The Forward Firewall is part of the original equipment manufacturer supplied for the 230 and 430 helicopter. For description see Bell 230 and 430 technical manuals.
- b. Structural Assembly / Bypass Door / Seal - The Bypass Door Assembly consists of a machined aluminum door, a machined aluminum alloy actuator bracket, a military standard (MS) aluminum alloy hinge and steel pin. The Structural Assembly consists of machined aluminum components, bent aluminum sheet metal components, mounting provisions for the upper and forward filter assemblies.

### 8.2.3 SYSTEMS AND ELECTRICAL COMPONENTS

(Refer to Appendix A, Figure A-12)

- a. Cockpit Switch/Indicator – This switch serves a dual purpose, it activates the bypass door as well as indicates that the filter is dirty. The switch is a push button type used to open or close the bypass door. The indicator is a split light that when the filter becomes dirty the upper segment will illuminate “FILTER” and as soon as the bypass door is fully opened the lower will illuminate “BYPASS”. The construction details of the component do not warrant field maintenance. Repair or servicing of this component requires the component to be sent back to AFS for disposition.
- b. Differential Pressure Switch - The Differential Pressure Switch provides a signal to the Cockpit Indicator for annunciation of the IBF “FILTER” light to signal that the differential pressure across the Filter Assembly has reached a preset value. The construction details of the component do not warrant field maintenance. Repair of this component requires the component to be sent back to AFS for disposition or replacement.
- c. Filter Maintenance Aid - The Filter Maintenance Aid provides an indication to maintenance personnel as to the trend of the differential pressure across the Filter Assembly. The construction details of the component do not warrant field maintenance. Repair of this component requires it to be sent back to AFS for disposition or replacement. The FMA is an

aid to help maintenance personnel and pilots to ascertain the current condition or trend accumulation of dirt on the Filter Assembly.

- d. Actuator - The Actuator is an electro-mechanical device that provides mechanical actuation of the Bypass Door when the cockpit switch is pushed to open or close the bypass door. The construction details of the component do not warrant field maintenance. Repair of this component requires the component to be sent back to AFS for disposition or replacement.
- e. Wiring, Wiring Harness, Connectors, Backshells, Circuit Breaker – The wiring and wiring harness utilizes wire per Military Specification Mil-W-22759/41. The gauge and marking identification is specified on the wiring diagram. The connectors, backshells, and circuit breaker are military specification components, or where applicable, vendor designed components. The construction details of these components (other than wiring) do not warrant field maintenance.

### **8.3 FILTER ASSY / FILTER SEAL** (Refer to Appendix A, Figure A-10 & 11)

#### **8.3.1 FORWARD FILTER ASSY**

##### **8.3.1.1 Removal – Filter Assy**

#### **CAUTION**

**UPON REMOVAL OF THE FILTER ASSEMBLY, COVER THE ENGINE INLET TO ENSURE IT IS PROTECTED FROM FOREIGN OBJECT DAMAGE (FOD).**

- a. Remove the L/H or R/H Air Inlet Cowl whichever is applicable.
- b. Disconnect the electrical connector from the Differential Pressure Switch.
- c. Disconnect the hose assembly from the fitting located on the firewall flange.
- d. Remove the Air Intake Plenum.
- e. Remove the five (5) captive fasteners securing the Forward Filter Assembly to the Upper Filter Assembly.
- f. Remove the five (5) captive fasteners securing the Forward Filter Assembly to the Structural Assembly and Support Bracket.

### 8.3.1.2 Inspection – Filter Assy

#### NOTE

**After servicing of the Filter Assembly or at any time the Filter Assembly is inspected, the pleats may require straightening or crimping. If you cannot see the bottom of the pleat, the airflow will be restricted and/or the pleats will adhere to one another when dirt loaded. Any restriction to the flow through the pleats will result in increased differential pressure and reduction in dirt loading capacity. In order to ensure ideal flow characteristics through the filter media, the pleats must be straightened or crimped with a hand seamer.**

- a. Visually inspect the pleats on both sides of the filter. If you cannot see the bottom of the pleat, when sighting the length, or depth of the pleat, straightening of the pleat is required. Refer to “Adjustment” for pleat straightening procedures.
- b. If this inspection is in response to an IBF “FILTER” light indication or failed PAC, perform troubleshooting per Table 3. If troubleshooting indicates a dirty filter, service filter per Section 7.3.
- c. Inspect the Filter Assembly frame for cracks, gouges, distortion or deformation, corrosion, loose or missing fasteners, and missing or deteriorated protective coating. Refer to “Repair” for criteria / disposition.
- d. Inspect the Filter Seal. Refer to “Filter Seal” procedures.

### 8.3.1.3 Troubleshooting – Filter Assy

See Table 3 for troubleshooting guide.

### 8.3.1.4 Adjustment - Filter

#### CAUTION

**HAND SEAMER MUST BE LIMITED TO A MAXIMUM JAW DEPTH OF 1 1/4 INCH. A DEEPER JAW DEPTH CAN RESULT IN DEFORMATION OR DAMAGE TO THE ADJOINING PLEATS.**

### CAUTION

**DO NOT OVER CRIMP AND CRUSH PLEAT; CARE MUST BE TAKEN TO SQUEEZE THE PLEATS WITHOUT DAMAGING THE PLEATED SCREEN. THE RADIUS AT THE TOP OF THE PLEAT SHOULD REMAIN INTACT, NOT CREASED.**

- a. If you cannot see the bottom of a pleat, use a hand seamer (See Special Tools / Special Equipment, Section 8.9(a)) to crimp the pleat and to straighten the pleat. Sight down the length and depth of the pleat to confirm the pleat is straightened (See Picture 5).
- b. Once one side is crimped, flip the filter over and crimp the other side as required following the guidance above. Use caution not to crush the pleats when straightening them. Use care to maintain the original radius, as much as possible, at the top of the pleat.



**Picture 5: Hand Seamer Used to Straighten or Crimp Pleats**

#### 8.3.1.5 Calibration

Not applicable.

#### 8.3.1.6 Repair - Filter Media, General

### **WARNING**

**ADHESIVE VAPORS (SUCH AS MAY BE CONTAINED IN SEALING MATERIAL AMS 3276 OR MIL-S- 8802), MAY CAUSE IRRITATION OF EYES, NOSE, AND RESPIRATORY SYSTEM. EYE AND SKIN CONTACT WITH MATERIAL MAY CAUSE IRRITATION. IF INGESTED, MAY CAUSE GASTRIC DISTRESS. FLUSH EYES WITH WATER FOR 15 MINUTES. WASH SKIN WITH SOAP AND WATER. IF INHALED, MOVE TO FRESH AIR. IN ALL CASES GET IMMEDIATE MEDICAL ATTENTION. WORK IN A WELL-VENTILATED AREA. WEAR GLOVES AND SAFETY GLASSES.**

## NOTE

**Repair filter media damage after cleaning but prior to oiling of filters.**

### 8.3.1.7 Repair - Filter Media, Small Ruptures, Tears, or Holes

- a. In the event of damage to the filter media, ruptures in the filter media may be repaired. Small ruptures defined as smaller than .500 inch diameter or length can be sealed without degradation of performance to the Filter Assembly. Up to 8 small ruptures in the filter media may be repaired on a single filter, but no repair may be within 1” of an adjacent repair.
- b. Prior to performing any of these repairs, the filter material must be cleaned of contamination and oil. Refer to Chapter 7 for cleaning the Filter Assembly. Perform the repair to a cleaned and dry Filter Assembly. Each time the entire Filter Assembly is cleaned, repaired, and oiled, a mark shall be scribed on the Filter Assembly data plate in accordance with Section 6.2 indicating a cleaning cycle has been performed.
- c. Trim ruptures, tears, or holes in the filter media up to .500 inches in length or diameter to remove loose material (wire or cotton gauze).
- d. Seal the affected area using two-part Sealant, AMS 3276 or MIL-S-8802. Allow the Sealant to bleed into the filter material and cure. Follow manufacturer’s directions for proper mixing, application, and curing of the two-part Sealant.
- e. Proceed with oiling the filter. Refer to Chapter 7.

### 8.3.1.8 Repair - Filter Media, Large Ruptures, Tears, or Holes

Larger ruptures exceeding .500 inch in size are not repairable in the field. Contact AFS for disposition and possible repair procedures, or discard the Filter Assembly.

### 8.3.1.9 Repair – Filter Assy, Other Damage

- a. The repair procedures defined above are for damage resulting in ruptures, tears, or holes in the filter media. The following is for field repairable damage to the Filter Assembly frame. Field repairable damage to the Filter Assembly frame is limited to blending of scratches and gouges, and / or the re-application of protective coatings. See Table 2 for application of protective coatings.
- b. Any damage to the filter frame such as cracking requires the Filter Assembly be returned to AFS for evaluation and disposition or replacement. Any damage to the filter frames such as warping or distortion (to the extent that the Filter Frame, when installed against the Upper Fairing Assembly does not permit the Filter Assembly to sit flush against the Upper Fairing) requires the Filter Assembly be returned to AFS for evaluation and disposition or replacement.

## **8.3.2 UPPER FILTER ASSY**

### **8.3.2.1 Removal – Filter Assy**

#### **CAUTION**

**UPON REMOVAL OF THE FILTER ASSEMBLY, COVER THE ENGINE INLET TO ENSURE IT IS PROTECTED FROM FOREIGN OBJECT DAMAGE (FOD).**

- g. Remove the L/H or R/H Air Inlet Cowl whichever is applicable.
- h. Disconnect the electrical connector from the Differential Pressure Switch.
- i. Disconnect the hose assembly from the fitting located on the firewall flange.
- j. Remove the Air Intake Plenum.
- k. Remove the Forward Filter Assembly (See Section 8.3.1.1).
- l. Remove the six (6) NAS6203-3 bolts and NAS620-10 washers securing the Upper Filter Assembly to the firewall.

### **8.3.2.2 Inspection – Filter Assy**

See Section 8.3.1.2

### **8.3.2.3 Troubleshooting – Filter Assy**

See Table 3 for troubleshooting guide.

### **8.3.2.4 Adjustment - Filter**

See Section 8.3.1.4

### **8.3.2.5 Calibration**

Not applicable.

### **8.3.2.6 Repair - Filter Media, General**

See Section 8.3.1.6

### **8.3.2.7 Repair - Filter Media, Small Ruptures, Tears, or Holes**

See Section 8.3.1.7

### **8.3.2.8 Repair - Filter Media, Large Ruptures, Tears, or Holes**

See Section 8.3.1.8

### **8.3.2.9 Repair – Filter Assy, Other Damage**

See Section 8.3.1.9

### **8.3.2.10 Installation – Filter Assy**

#### **CAUTION**

**REMOVE COVER FROM THE ENGINE INLET PRIOR TO INSTALLING THE FILTER ASSEMBLY.**

#### **CAUTION**

**OVER TIGHTENING OF THE FASTENERS MAY RESULT IN THE FASTENER BEING DAMAGED.**

- a. Carefully position the Forward Filter Assembly against the Upper Filter Assembly, the Bypass Structural Assembly, and the Filter Support.
- b. Install the ten (10) captive fasteners securing the Filter Assembly to the Upper Filter Assembly, the Bypass Structural Assembly, and the Filter Support.

### **8.3.3 FILTER SEALS**

#### **8.3.3.1 Removal**

Forward Filter Assembly

- a. Gain access to the Filter Seal by removing the Filter Assembly. Refer to Section 8.3.1.1.
- b. Remove the twenty-one (21) MS27039 bolts that that secure the seal to the Filter Assembly.
- c. Remove the retainer and seal, if seal is to be reused, be careful not to damage the seal.
- d. Carefully remove the Seal by peeling it away from the Filter Assembly. Use a plastic scraper or other suitable tool that won't damage the Filter Assembly to peel the Seal from the Filter Assembly. Discard the removed Seal.

Upper Filter Assembly

- a. Gain access to the Filter Seal by removing the Filter Assembly. Refer to Section 8.3.2.1.

This filter contains three (3) seals, two are held in place with adhesive and one is held in place with fasteners.

#### Aft Seal

- a. Use a plastic scraper to gently scrape the seal off the Filter Assembly.

#### Inboard Seal

- a. Use a plastic scraper to gently scrape the seal off the Filter Assembly.

#### Outboard Seal

- a. Remove the eight (8) MS27039 bolts that that secure the seal to the Filter Assembly.
- b. Remove the retainer and seal, if the seal is to be reused, be careful not to damage the seal.

### 8.3.3.2 Inspection

Inspect the Filter Seal for any tears, nicks, gouges, missing pieces or a permanent set or flattening of the Seal. If the Seal exhibits any of these conditions, repair or replace the Seal.

### 8.3.3.3 Repair

#### **WARNING**

**ADHESIVE VAPORS (IN SEALANT SUCH AS RTV 736) MAY CAUSE IRRITATION OF EYES, NOSE, AND RESPIRATORY SYSTEM. EYE AND SKIN CONTACT WITH MATERIAL MAY CAUSE IRRITATION. IF INGESTED, MAY CAUSE GASTRIC DISTRESS. FLUSH EYES WITH WATER FOR 15 MINUTES. WASH SKIN WITH SOAP AND WATER. IF INHALED, MOVE TO FRESH AIR. IN ALL CASES GET IMMEDIATE MEDICAL ATTENTION. WORK IN A WELL-VENTILATED AREA. WEAR GLOVES AND SAFETY GLASSES.**

- a. Small tears, nicks, or gouges in the Seal may be repaired using RTV 736 Sealant or equivalent. Use a wooden tongue depressor, cotton swab, or similar tool to dab a small amount of Sealant on the damage to repair tears, nicks, or gouges in the Seal. Smooth over Sealant to create a smooth flush repair similar to the original Seal cross section. Allow to dry before re-installing filter. If the repair does not allow the Filter Assembly to properly seal against the Adapter replace the Seal.
- b. If the Seal exhibits extensive tears, deep nicks or gouges, or missing pieces that would prevent the filter from properly sealing, replace the Seal.

### 8.3.3.4 Installation

- a. Gain access to the Filter Seals. Refer to Sections 8.3.1.1 and 8.3.2.1

#### Forward Filter Assembly



- b. To install the Seal, clean surface of Filter Frame, locate and bond Seal in place using Dow Corning RTV 736 or equivalent.
- c. Locate the retainer on the Seal.
- d. Install the twenty-two (22) MS27039 bolts that that secure the seal to the Filter Assembly.

#### Upper Filter Assembly

This filter contains three (3) seals, two are held in place with adhesive and one is held in place with fasteners.

#### Aft Seal

- a. To install the Seal, clean surface of Aft Bracket, locate and bond Seal in place using Dow Corning RTV 736 or equivalent.

#### Inboard Seal

- b. To install the Seal, clean surface of Filter Frame, locate and bond Seal in place using Dow Corning RTV 736 or equivalent.

#### Outboard Seal

- c. To install the Seal, clean surface of Outboard Bracket, locate and bond Seal in place using Dow Corning RTV 736 or equivalent.
- d. Locate the retainer on the Seal.
- e. Install the eight (8) MS27039 bolts that that secure the seal to the Bracket.

## **8.4 STRUCTURAL COMPONENTS**

### **8.4.1 BYPASS STRUCTURAL ASSY**

(Refer to Appendix A, Figure A-2)

#### **8.4.1.1 Removal**

- a. Remove the L/H or R/H Air Inlet Cowl whichever is applicable.
- b. Disconnect the electrical connector from the Differential Pressure Switch.
- c. Disconnect the hose assembly from the fitting located on the firewall flange.
- d. Remove the Inboard and Outboard Air Intake Plenum.
- e. Remove the Forward Filter. (See Section 8.3.1.1)
- f. Remove the Upper Filter. (See Section 8.3.2.1)

- g. Disconnect the actuator electrical connector from the wire harness.
- h. Disconnect the wire harness from the firewall connector.
- i. Remove the wire harness from the bracket located on the Bypass Structural Assembly.
- j. Remove the wire clamps securing the wire harness to the Bypass Structural Assembly and the center wall.
- k. Remove the two NAS6203-4 bolts, NAS1149D0332J washers, and MS21042L3 nuts securing the lower horizontal bracket to the lower firewall flange.
- l. Remove the four MS27039-08-08 screws and NAS1149DN832J washers securing the Bypass Structural Assembly to the upper firewall flange.
- m. Remove the two NASM3H4A bolts, NAS1149D0316J washers, and MS21042L3 nuts securing the lower angled bracket to the lower firewall flange.
- n. Remove the five NAS6203 bolts and NAS1149D0363J washers securing the Bypass Structural Assembly to the aft section of the firewall.

#### **8.4.1.2 Inspection**

- a. Cracking. Visually inspect the Bypass Structural Assembly and related parts for cracking using 10x magnifications at the corners, radii, and transitions in part thickness. Any fretting of faying surfaces, such as those at a crack, may emit a black or grey dust or soot like material indicative of a crack. Inspect suspect areas carefully using the 10x magnification. Refer to adjustment / calibration / repair for disposition of cracks in the Bypass Structural Assembly or parts.
- b. Reserved.
- c. Protective Coatings. Visually inspect the Bypass Door Assembly and related parts for missing, damaged, or “scratched through” protective coatings. Re-apply protective coatings per Table 2 of this chapter.
- d. Corrosion. Visually inspect the Bypass Structural Assembly and related parts for corrosion in accordance with AC 43.13-1, Chapter 6 and Table 2.
- e. Missing, damaged or loose associated components. Visually inspect the Bypass Structural Assembly for missing damaged or loose components.

#### **8.4.1.3 Troubleshooting**

Not applicable.

#### **8.4.1.4 Calibration / Adjustment**

Not applicable.

#### **8.4.1.5 Repair**

- a. Cracks. No un-repaired cracks are allowed in the Bypass Structural Assembly. Contact AFS for disposition and possible repairs.
- b. Warping or distortion. Contact AFS for disposition and possible repairs.
- c. Protective Coatings. Re-apply protective coatings per Table 2 of this chapter.
- d. Corrosion. Treat corrosion in accordance with AC 43.13-1, Chapter 6 and Table 2.
- e. Missing, damaged or loose associated components. Replace missing or damaged components, secure loose components.

#### **8.4.1.6 Installation**

- a. Install five NAS6203 bolts and NAS1149D0363J washers to secure the Bypass Structural Assembly to the aft section of the firewall.
- b. Install the two NASM3H4A bolts, NAS1149D0316J washers, and MS21042L3 nuts to secure the lower angled bracket to the lower firewall flange.
- c. Install four MS27039-0808 screws and NAS1149DN832J washers to secure the Bypass Structural Assembly to the upper firewall flange.
- d. Install two NAS6203-4 bolts, NAS1149D0332J washers, and MS21042L3 nuts to secure the lower horizontal bracket to the lower firewall flange.
- e. Secure the wire harness to the Bypass Structural Assembly and the center wall using MS21919WDG2 clamps and NAS6203-2 bolts.
- f. Secure the Actuator connector on the wire harness to the bracket located on the Bypass Structural Assembly.
- g. Connect wire harness to firewall connector.
- h. Connect Actuator.
- i. Seal aft inboard and bottom inboard interface between the Bypass Structural Assembly and the firewall using Mil-S-8802 sealant.

## **8.5 SYSTEMS AND ELECTRICAL COMPONENTS**

### **8.5.1 COCKPIT SWITCH/INDICATOR**

(Refer to Appendix A, Figure A-12)

#### **8.5.1.1 Removal**

- a. Gain access to the back of the instrument panel.
- b. Remove connector at back of Cockpit Switch / Indicator.
- c. Remove Cockpit Switch / Indicator cover.
- d. Turn lug ¼ turn counter clockwise to unlock Cockpit Switch / Indicator from panel.
- e. Slide Cockpit Switch / Indicator out of panel.
- f. Tag and secure wiring.

#### **8.5.1.2 Inspection**

- a. Inspect Cockpit Switch/Indicator for proper functioning. Refer to Section 8.5.2.5, and to Table 3 for troubleshooting.
- b. Inspect Cockpit Indicator for security, damage, overheating, corrosion, or distortion. Replace defective component or contact AFS for disposition.

#### **8.5.1.3 Troubleshooting**

See Table 3 for troubleshooting guide.

#### **8.5.1.4 Adjustment / Calibration / Repair**

Not applicable. Contact AFS for disposition of defective component or replace.

#### **8.5.1.5 Function Check – “BYPASS” Indication**

### **CAUTION**

**THIS PROCEDURE INTRODUCES THE POSSIBILITY OF ENGINE FOD.**

- a. Verify the Bypass Door is closed and aircraft electric power is ON.
- b. Press Cockpit Switch / Indicator (IBF 1 or IBF 2) to open the Bypass Door.

- c. The word “BYPASS” should illuminate on the lower segment of the respective Cockpit Switch / Indicator when the door reaches the full open position.
- d. Verify the respective Bypass Door is open.
- e. Press the Cockpit Switch / Indicator again to close the Bypass Door.
- f. The word “BYPASS” should extinguish on the lower segment of the Cockpit Switch / Indicator.
- g. Verify the Bypass Door is closed and aircraft electric power is OFF.

#### **8.5.1.6 Function Check – “FILTER” Indication**

- a. Perform Differential Pressure Switch function check per Section 8.5.2.5.
- b. Verify Cockpit Switch / Indicator “FILTER” amber light illuminates.

#### **8.5.1.7 Installation**

- a. Slide Cockpit Switch / Indicator into panel opening in correct orientation.
- b. Open switch cover. Turn lug ¼ turn clockwise to lock Cockpit Switch / Indicator into panel.
- c. Attach connector at rear of Cockpit Switch / Indicator.
- d. Perform Cockpit Switch / Indicator Function Check.

### **8.5.2 DIFFERENTIAL PRESSURE SWITCH**

(Refer to Appendix A, Figures A-8)

#### **8.5.2.1 Removal**

- a. Gain access inside the L/H or R/H Air Intake Cowling, whichever is applicable.
- b. Remove hoses, fittings, and attaching hardware from the Differential Pressure Switch.
- c. Disconnect and secure electrical connector.
- d. Remove Differential Pressure Switch.

#### **8.5.2.2 Inspection**

Inspect for general serviceability, damage, corrosion, and missing components. Inspect the attaching hardware for security.

#### **8.5.2.3 Troubleshooting**

See Table 3 for troubleshooting guidance.

#### 8.5.2.4 Adjustment / Calibration / Repair

##### NOTE

**If problems are suspected with the differential pressure switch, disconnect the supply line connecting the pressure switch to the static port and clean and flush the line and static port.**

The construction details of the component do not warrant field maintenance beyond that noted above. Repair of this component requires the component to be sent back to AFS for disposition.

#### 8.5.2.5 Function Check

##### CAUTION

**THIS PROCEDURE INTRODUCES THE POSSIBILITY OF ENGINE FOD.**

##### CAUTION

**IMPROPER USE OF THE ALTIMETER TEST SET COULD RESULT IN DAMAGE TO THE SWITCH AND/OR SWITCH CALIBRATION.**

##### CAUTION

**PULLING AN ALTITUDE OF GREATER THAN 1880 FEET ABOVE FIELD ELEVATION WILL DAMAGE THE DIFFERENTIAL PRESSURE SWITCH.**

- a. Gain access to the DP low pressure static port below the Bypass Door.
- b. Connect the low pressure calibrator or altimeter test set to the plenum side of the DP switch by slipping a piece of 3/16 inch ID vinyl tubing over the end of the differential pressure switch static port. Ensure that the fit between the tube and the static port is tight, i.e. no leakage.
- c. Ensuring that aircraft electrical power is ON, operate the test set to an indicated altitude above the field elevation and gradually increase altitude. The differential pressure switch should actuate and send a signal to the Cockpit Indicator illuminating the IBF "FILTER" light within the following range:

Test Method	Test Station Elevation (ft)					
	0	2000	4000	6000	8000	10000
Low Pressure Calibrator (inches of H <sub>2</sub> O)	11.0 ± 1.1					
Altimeter Test Set (ft above test station elevation)	760 ±80 ft	800 ±80 ft	850 ±90 ft	910 ±90 ft	970 ±100 ft	1030 ±100 ft

- d. If the Cockpit Indicator does not illuminate, pull IBF circuit breaker. Run the altimeter test set up to top of the range, check for continuity across the terminals of the Differential Pressure Switch. If continuity is present, the Differential Pressure Switch function is acceptable and the rest of the circuit is suspect. Upon completion of testing, ensure that aircraft electrical power is OFF. Refer to Table 3.

**WARNING**

Applying a vacuum greater than 221 in-H<sub>2</sub>O (8 psi) may result in damaging the DP switch.

- e. This will functionally check both the differential pressure switch and the IBF “FILTER” Cockpit Indicator.

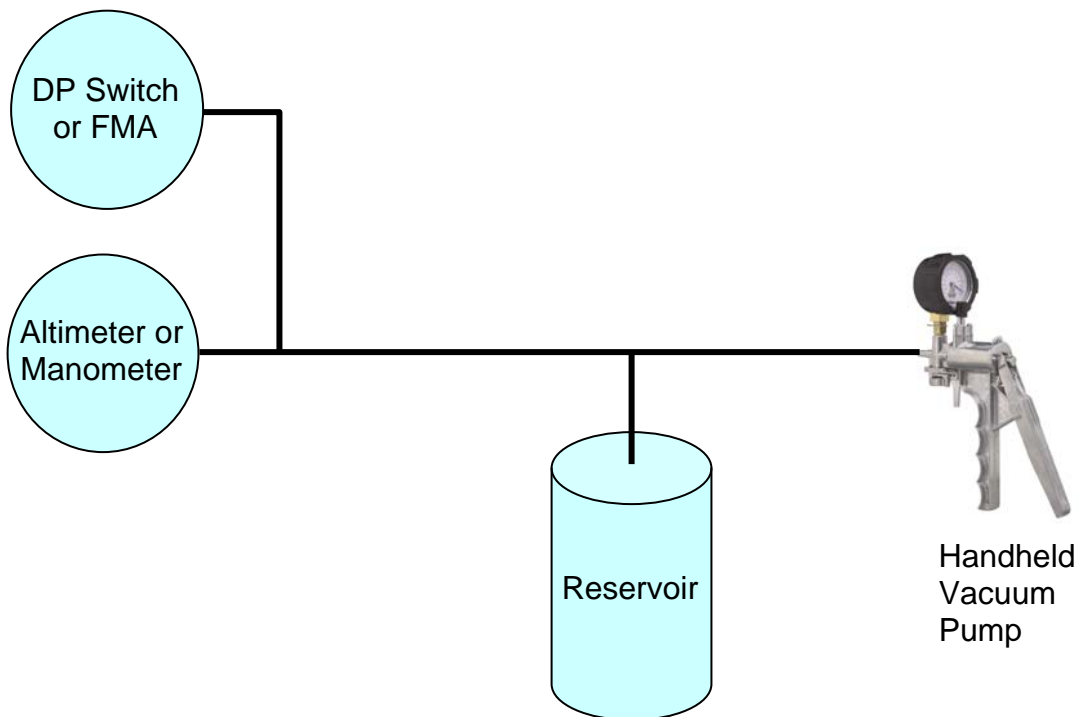

**Figure 4: Test Equipment Setup**



**Picture 6: Test Setup with Manometer**

### **8.5.2.6 Installation**

- a. Gain access inside the L/H or R/H Air Intake Cowling, whichever is applicable.
- b. Properly orient the Differential Pressure Switch in the Clamp.
- c. Attach hoses, fittings, and attaching hardware.
- d. Connect and secure connector.
- e. Perform Function Check of Differential Pressure Switch (Refer to Section 8.5.2.5).

### **8.5.3 FILTER MAINTENANCE AID**

(Refer to Picture 1 & Figure 2 and Appendix A, Figures A-7 & A-9)

#### **8.5.3.1 Removal**

- a. Gain access inside the L/H or R/H Air Intake Cowling, whichever is applicable.
- b. Disconnect Tube Assembly from Filter Maintenance Aid.
- c. Remove hardware and retainer from Filter Maintenance Aid.



d. Remove Filter Maintenance Aid.

### **8.5.3.2 Inspection**

- a. Inspect the Filter Maintenance Aid and associated mounting for discoloration affecting readability, cracks, deformation, missing or damaged components, and serviceability.
- b. Inspect the Filter Maintenance Aid Plenum Tube Assembly for debris and insure that the tube is clear and unobstructed.
- c. Inspect the associated components, such as the Mount Assembly and hardware for missing components, cracks, distortion or deformation, scratches or gouges, or missing protective coatings.

### **8.5.3.3 Troubleshooting**

See Troubleshooting Guide, Table 3.

### **8.5.3.4 Calibration / Repair**

The construction details of the component do not warrant field maintenance. Repair of this component requires the component to be sent back to AFS for disposition, or replacement.

### **8.5.3.5 Adjustment**

The Filter Maintenance Aid is designed to hold the highest differential pressure across the filter assembly reached during the last flight, and can be reset by depressing the yellow button marked "PUSH TO RESET" located on the end of the filter maintenance aid (See Figure 2).

### **8.5.3.6 Repair**

- a. The construction details of the component do not warrant field maintenance. Repair of this component requires the component to be sent back to AFS for disposition, or replaced.
- b. If the Filter Maintenance Aid fails the function check, disconnect the plenum tube assembly from the Filter Maintenance Aid, and inspect for damage or blockage of the tube assembly. Inspect the opening on the Filter Maintenance Aid for obstructions. Remove obstructions as required. Reattach tube assembly and perform function check (Refer to Section 8.5.3.7). If it fails function check, replace FMA.
- c. Replace damaged sheet metal components of the mount assembly and missing or damaged hardware.
- d. Re-apply corrosion protection to mount hardware per Table 2.

### 8.5.3.7 Function Check

**CAUTION**

**THIS PROCEDURE INTRODUCES THE POSSIBILITY OF ENGINE FOD.**

**CAUTION**

**IMPROPER USE OF THE ALTIMETER TEST SET COULD RESULT IN DAMAGE TO THE FILTER MAINTENANCE AID.**

**CAUTION**

**IMPROPER USE OF THE ALTIMETER TEST SET SUCH AS PULLING AN ALTITUDE OF GREATER THAN 1880 FEET ABOVE FIELD ELEVATION WILL DAMAGE THE FILTER MAINTENANCE AID.**

- a. Gain access inside the L/H or R/H Air Intake Cowling, whichever is applicable.
- b. Connect the Barfield (or equivalent) altimeter test set vacuum system to the plenum tube assembly, by slipping a piece of 3/16 inch ID vinyl tubing over the end of the tube assembly. Ensure that the fit between the tubing and tube assembly is tight, i.e., no leakage.
- c. Reset the Filter Maintenance Aid by depressing the yellow button marked “PUSH TO RESET” located on the end of the filter maintenance aid (See Picture 1).
- d. The maintenance aid should indicate in the red zone within the following range:

Test Method	Test Station Elevation (ft)					
	0	2000	4000	6000	8000	10000
Low Pressure Calibrator (inches of H <sub>2</sub> O)	11.0 ± 1.1					
Altimeter Test Set (ft above test station elevation)	760 ±80 ft	800 ±80 ft	850 ±90 ft	910 ±90 ft	970 ±100 ft	1030 ±100 ft

### 8.5.3.8 Installation

- a. Gain access inside the L/H or R/H Air Intake Cowling, whichever is applicable.
- b. Position the Filter Maintenance Aid into the mount assembly.
- c. Install hardware and connect Tube Assembly.

## **8.5.4 ACTUATOR**

(Refer to Appendix A, Figures A-2 & A-4)

### **8.5.4.1 Removal**

- a. Gain access inside the L/H or R/H Air Intake Cowling, whichever is applicable.
- b. Remove the inboard and outboard Inlet Plenum.
- c. Remove the Forward Filter Assembly (See Section 8.3.1.1).
- d. Open the Bypass Door.
- e. Remove hardware attaching the Actuator to the Bypass Door.
- f. Remove hardware attaching the Actuator to the Actuator Support.
- g. Disconnect and secure electrical connector at Actuator.
- h. Remove Actuator.

### **8.5.4.2 Inspection**

- a. Inspect Actuator for cracks, damage, serviceability, corrosion, and security of installation.
- b. Inspect the connector for damage, security, corrosion and serviceability.
- c. Inspect the Bypass Door contact to the Bypass Door Seal. The Seal should be evenly compressed to approximately 15% of its non-compressed cross-section with no visible gaps. Use care not to damage the seal when checking for gaps / compression of the Seal. Refer to Adjustment if Seal compression is discrepant.

### **8.5.4.3 Troubleshooting**

- a. Refer to Table 3 for troubleshooting guidance.
- b. Perform Function Check. If Function Check indicates a discrepancy with the Actuator replace the actuator.

### **8.5.4.4 Adjustment**

- a. Clear the area of the Bypass Door of any tools, hardware, or other obstructions.
- b. After ensuring that aircraft power is ON, move the IBF BYPASS Cockpit Switch from the CLOSED to the OPEN position to actuate the Actuator to open the bypass door (this fully extends the actuator rod). If not, contact AFS for disposition or replace actuator.

- c. Remove hardware from Actuator rod end at Bypass Door.

**CAUTION**

**TO PREVENT INTERNAL DAMAGE TO THE ACTUATOR, HOLD THE ROD END WHILE LOOSENING, TIGHTENING, OR APPLYING TORQUE TO THE JAMB NUT.**

**CAUTION**

**INSTALL THE ACTUATOR BOLT TO THE BYPASS DOOR CLEVIS PLATE IN THE CORRECT ORIENTATION. FAILURE TO CORRECTLY INSTALL THE BOLT WILL RESULT IN DAMAGE TO THE BYPASS DOOR AND ACTUATOR.**

- d. Loosen jamb nut and adjust rod end in or out, as required, one-half turn to attain greater or less Seal compression to the Bypass Door.
- e. Temporarily re-install rod end bolt through the Bypass Door Clevis Plate (washers do not need to be installed until final adjustment is complete). Move IBF BYPASS Cockpit Switch to the CLOSED position to retract the Bypass Door. The Seal should be uniformly compressed approximately 15% of its non-compressed cross-section with no visible gaps. Use care not to damage the seal when checking for gaps / compression of the Seal. Refer to Adjustments if Seal compression is discrepant.
- f. Repeat steps b through e until the Seal is compressed correctly.
- g. Permanently install hardware to attach the Actuator rod end to the Bypass Door Clevis Plate. Torque jamb nut 25 TO 30 INCH-POUNDS. Torque nut 30 TO 40 INCH-POUNDS.
- h. Perform function check per Section 8.5.5.7.
- i. Move IBF BYPASS Cockpit Switch to the CLOSED position to close the Bypass Door and then ensure that aircraft power is OFF.

#### **8.5.4.5 Calibration**

Not applicable.

#### **8.5.4.6 Repair**

- a. Damage to the actuator, such as cracking of the attachment lug, distortion, warping, or failure to actuate requires disposition by AFS or replacement.
- b. The Actuator rod end and attachment hardware can also be replaced if they are damaged, corroded, or unserviceable. Replace the Actuator rod end by loosening the jamb nut and

removing / replacing the rod end. Perform the Actuator / Bypass Door Adjustment procedure per Section 8.5.4.4.

#### **8.5.4.7 Function Check**

- a. Gain access to the area below the Bypass Door (Refer to Sections 4.3 & 4.3), and clear the area of any tools, hardware, or other obstructions.
- b. With aircraft power ON, push the IBF BYPASS Cockpit Switch in to actuate the Actuator to open the bypass door (this fully extends the actuator rod). Verify the Bypass Door opens until the slope of the door is slightly beyond the slope of the filter.
- c. Push the IBF BYPASS Cockpit Switch in and verify that the bypass door is closed.
- d. Perform seal compression inspection and verify the seal is uniformly compressed to approximately 15% of its non-compressed cross-section with no visible gaps around the perimeter of the bypass door.
- e. Ensure aircraft power is OFF.
- f. If conditions are not met refer to Troubleshooting guide, Table 3, and Adjustment procedures, Section 8.5.4.4.

#### **8.5.4.8 Installation**

##### **CAUTION**

**THIS PROCEDURE INTRODUCES THE POSSIBILITY OF ENGINE FOD.**

##### **CAUTION**

**TO PREVENT INTERNAL DAMAGE TO THE ACTUATOR, HOLD THE ROD END WHILE LOOSENING, TIGHTENING, OR APPLYING TORQUE TO THE JAMB NUT.**

##### **CAUTION**

**INSTALL THE ACTUATOR BOLT TO THE BYPASS DOOR CLEVIS PLATE IN THE CORRECT ORIENTATION. FAILURE TO CORRECTLY INSTALL THE BOLT WILL RESULT IN DAMAGE TO THE BYPASS DOOR AND ACTUATOR.**

- a. Gain access inside the L/H or R/H Air Intake Cowling, whichever is applicable.
- b. Clear the area of the Bypass Door of any tools, hardware, or other obstructions.

- c. Install the connector to the Actuator. Ensure aircraft power is ON. Move the IBF BYPASS Cockpit Switch to the OPEN position to fully extend the Actuator rod to bypass door open position.
- d. Orient actuator to the Bypass Door and Actuator Support.
- e. Install hardware attaching the Actuator to the Actuator Support.
- f. Temporarily install the bolt attaching the Actuator to the Bypass Door Clevis Plate.
- g. Perform Actuator / Bypass Door Adjustment procedure (See Sections 8.5.4.4).
- h. Confirm the permanent installation of hardware securing the Actuator rod end to the Bypass Door Clevis Plate and that aircraft power is OFF.

### **8.5.5 WIRING, WIRING HARNESS, CONNECTORS, BACKSHELLS, CIRCUIT BREAKER, RELAY**

(Refer to Appendix A, Figure A-12)

#### **8.5.5.1 Removal**

- a. Prepare aircraft for electrical system work by disconnecting the battery.
- b. Remove hardware, clamps and spiral wrap from component, as applicable. Tag interfacing components for later installation. Remove affected components.

#### **8.5.5.2 Inspection**

The IBF wiring, wiring harness and associated components are constructed of standard aircraft wire and connectors. Standard aircraft maintenance procedures should be used for inspections and repair of the harness and connectors. Routine aircraft maintenance should include visual inspection for evidence of chafing, damage, corrosion and insuring the circuit breaker and all pins, connectors, and backshells are secure. Inspect wiring, wiring harness and associated components per AC 43.13-1, Chapter 11.

#### **8.5.5.3 Troubleshooting**

- a. See Table 3 for troubleshooting guidance.
- b. See Appendix A, Figure A-9 for wiring diagram, wire marking and identification, routing, and installation information.

#### **8.5.5.4 Adjustment / Calibration**

Not applicable.

### **8.5.5.5 Repair**

Standard aircraft maintenance procedures should be used for repair of the wiring, wire harness and associated components. See Appendix A, Figure A-9 for wiring diagram, wire marking and identification, routing, and installation information. Perform repairs to affected components per AC 43.13-1, Chapter 11.

### **8.5.5.6 Installation**

- a. Prepare aircraft for work performed on the electrical system by disconnecting the battery.
- b. Install affected component using appropriate hardware. Connect wiring per wiring diagram. Install clamps, spiral wrap and heat shrink as applicable to affected components per AC 43.13-1, Chapter 11.

## **8.6 FASTENER LISTING**

Refer to Appendix A – Parts Figures for a listing of fasteners and their location.

## **8.7 PROTECTIVE TREATMENT**

- a. The IBF system is composed primarily of aluminum alloy materials, except for standard hardware components and fasteners, and vendor components. Aluminum components are coated with an epoxy primer. Scratched or damaged aluminum components should be touched up with a small paint brush. Prepare epoxy primer per manufacturers instructions.
- b. Aircraft finishes scratched or damaged should be recoated with the finish specified in the aircraft maintenance records and maintenance manual.
- c. For the systems and electrical components, there are no protective treatments specified. Contact AFS for disposition of damaged components, or replace the damaged component.

Component	Material	Limits of Damage	Protective Treatment
Filter Assembly	Alum. Alloy Sheet Stk.	Scratches, pitting, gouges must be less than 20% of part thickness. See note 1.	Alodine and Re-apply Epoxy Primer Ref Table 4
Bypass Door Assembly			
Bypass Door	Alum. Alloy Sheet Stk.	Scratches, pitting, gouges must be less than 20% of part thickness. See note 1.	Alodine and Re-apply Epoxy Primer Ref Table 4
Actuator Bracket	Alum. Alloy Sheet Stk.	Scratches, pitting, gouges must be less than 20% of part thickness. See note 1.	Alodine and Re-apply Epoxy Primer Ref Table 4
Filter Maintenance Aid Bracket	Alum. Alloy Sheet Stk.	Inspect for Serviceability	Alodine and Re-apply Epoxy Primer Ref Table 4
Filter Adapter Frame Assembly	Alum. Alloy Sheet Stk.	Scratches, pitting, gouges must be less than 20% of part thickness. See note 1.	Alodine and Re-apply Epoxy Primer Ref Table 4

**Table 2: Protective Treatment for Components**

Notes:

1. Contact AFS for disposition instructions for components with more severe discrepancies or replace component.



## 8.8 TROUBLESHOOTING GUIDE

The following table defines the probable cause, remedy, and ICA reference to the applicable procedure for correcting the trouble listed in the table. Multiple failures are not addressed in this table such as a failed actuator and failed wiring existing at the same time.

ITEM	TROUBLE	PROBABLE CAUSE	REMEDY	ICA REF
1	IBF FILTER light fails to illuminate	Faulty connector Faulty circuit Faulty cockpit indicator Faulty delta P switch	Check connectors to aircraft power, cockpit indicator and delta P switch. Check circuit continuity and repair circuit. Verify using function check procedures; replace cockpit indicator. Replace differential pressure switch.	Para. 8.5.5. Para. 8.5.5. Para. 8.5.1. Para. 8.5.2.
2	IBF FILTER light is dim	Failed bulb in indicator	Verify using function check procedures; replace cockpit indicator.	Para. 8.5.1.
3	IBF FILTER light stays illuminated	Bypass obstructed Faulty delta P switch	Clear bypass path. Replace differential pressure switch.	N/A Para. 8.5.2.
4	IBF Bypass door fails to close	Actuator misrigged Faulty connector Faulty circuit Faulty cockpit switch Faulty actuator	Check actuator rigging. Check connectors to aircraft power, cockpit switch and actuator. Check circuit continuity and repair circuit. Check switch continuity in CLOSED position; repair or replace cockpit switch. Replace actuator.	Para. 8.5.4. Para. 8.5.5. Para. 8.5.5. Para. 8.5.1. Para. 8.5.4.
5	IBF Bypass door fails to open	Actuator misrigged Faulty connector Faulty circuit Faulty cockpit switch Faulty actuator	Check actuator rigging. Check connectors to aircraft power, cockpit switch and actuator. Check circuit continuity and repair circuit. Check switch continuity in OPEN position; repair or replace cockpit switch. Replace actuator.	Para. 8.5.4. Para. 8.5.5. Para. 8.5.5. Para. 8.5.1. Para. 8.5.4.
6	IBF FILTER light illuminates	Obstructed inlet Dirty filter	Clear engine inlet. Check FMA & inspect filter; service filter.	N/A Para. 7.3.
7	Engine fails PAC	Obstructed inlet Dirty filter	Clear engine inlet. Verify EPC results, check FMA, & inspect filter; service filter. NOTE: If engine still fails EPC - check engine.	N/A Para. 7.3.
8	IBF FILTER fails to dim	Faulty aircraft dimmer circuit	Check aircraft dimmer circuit for caution/warning panel per Bell manual.	N/A
9	IBF FILTER fails to brighten	Faulty aircraft dimmer circuit	Check aircraft dimmer circuit for caution/warning panel per Bell manual.	N/A

**Table 3: Troubleshooting Guide**

## 8.9 SPECIAL TOOLS / SPECIAL EQUIPMENT

### NOTE

**Standard Aircraft Mechanic Tools are not listed.**

- a. Hand Seamer with 1 1/4 inch maximum jaw depth – Required for straightening of the filter assembly pleats. Hand seamers are available through many commercial aircraft supply stores and also through commercial heating and air conditioning supply stores. Recommend the following: Malco Tools “Hand Seamer with Forged Steel Jaw”, Catalog # S2, S3 and S6. The S3 model is also available through Wicks Aircraft Supply, Part Number TP44-0, “Offset Hand Seamer”.
- b. Barfield or Equivalent Manufacturer Altimeter Test Set – Required for Function Check of the Differential Pressure Switch and Filter Maintenance Aid.

### 8.9.1 CONSUMABLE MATERIALS, SUPPLIES, AND PROTECTIVE TREATMENT SPECIFICATIONS

Item	Description	Spec / Part No.
<b>Consumables</b>		
1	Sealant	AMS 3276
2	Sealant	Mil-S-8802
3	Sealant	RTV 736
<b>Supplies</b>		
6	Air Filter Oil	6.5 oz. squeeze bottle – 100100-065
6.1	Air Filter Oil	9 oz. squeeze bottle – 100100-090
6.2	Air Filter Oil	1 gal. container – 100101-000
7	Air Filter Cleaner	1 gal. container – 100201-000
7.1	Air Filter Cleaner	5 gal. container – 100205-000
<b>Protective Treatment Specs</b>		
8	Epoxy Primer.	MIL-PRF-23337
9	Chemical Conversion Coating	MIL-C-5541 (One commercial trade name, “Alodine”)
10	Aircraft Finish	See Aircraft Records for appropriate Finish / Top Coat.

**Table 4: Consumable Materials, Supplies and Protective Treatment Specifications**

## 9 ICA APPENDIX A – ILLUSTRATED PARTS BREAKDOWN

### TABLE OF CONTENTS

Figure A-1: IBF.....	A-2
Figure A-2: Bypass Structural Assy .....	A-4
Figure A-3: Bypass Structural Sub-Assy.....	A-6
Figure A-4: Actuator Mechanism .....	A-9
Figure A-5: Bypass Screen Assembly .....	A-11
Figure A-6: Bypass Door Assembly .....	A-13
Figure A-7: FMA & Delta P Assembly .....	A-15
Figure A-8: Differential Pressure Assembly.....	A-17
Figure A-9: FMA Assembly .....	A-19
Figure A-10: Upper Filter Assembly .....	A-21
Figure A-11: Forward Filter Assembly.....	A-23
Figure A-12: FMA Interface Assembly.....	A-25
Figure A-13: Electrical Installation and Schematic .....	A-26

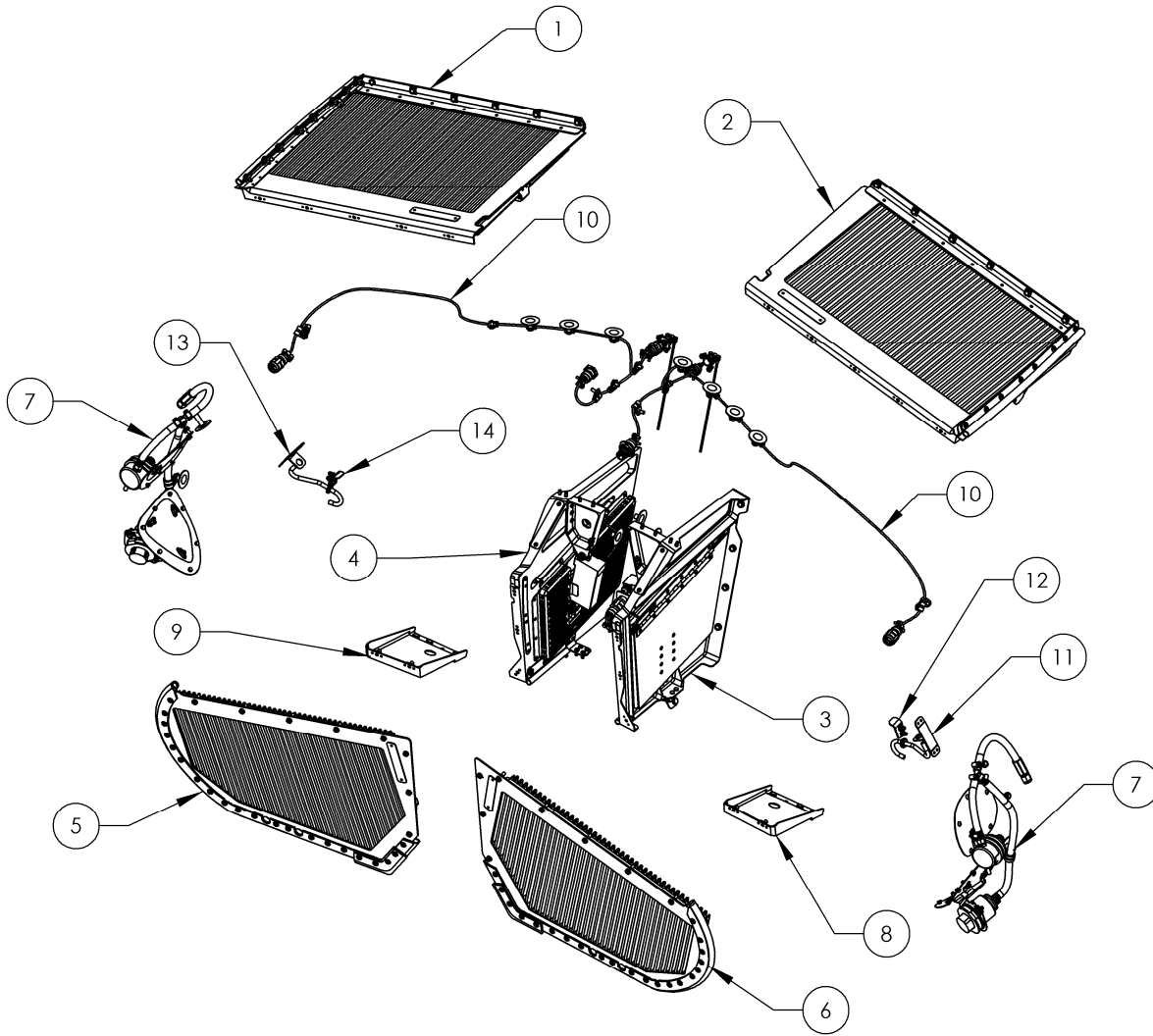

**Figure A-1: IBF**

INDEX NUMBER	PART NUMBER	ITEM NAME	UNIT PER ASSY	AVAIL
		FIGURE A-1: IBF		
	118000-101	Installation - IBF, System, Bell 430	REF	
1	118300-102	Assy - Filter, UPR (See Figure A-10 for breakdown)	1	P
2	118300-101	Assy - Filter, UPR (See Figure A-10 for breakdown)	1	P
3	118100-101	Assy - Closeout, Side (See Figure A-2 for breakdown)	1	P
4	118100-102	Assy - Closeout, Side (See Figure A-2 for breakdown)	1	P
5	118350-102	Assy - Filter, FWD (See Figure A-11 for breakdown)	1	P
6	118350-101	Assy - Filter, FWD (See Figure A-11 for breakdown)	1	P
7	118004-101	Kit - Sensor, IBF (See Figure A-7, for breakdown)	1	P
8	118360-101	Assy - Support, Filter, FWD	1	P
9	118360-102	Assy - Support, Filter, FWD	1	P
10	118400-101	Wire Harness	2	P
11	N/A	Assy - FMA Interface (See Figure A-12 for breakdown)	1	P
12	118317-201	Support - Top Filter, OUTBD	1	P
13	N/A	Assy - FMA Interface (See Figure A-12 for breakdown)	1	P
14	118317-202	Support - Top Filter, OUTBD	1	P
		<b>AVAIL CODE DEFINITION</b>		
		P           Procurable		
		NP         Non Procurable		
		SP         Normal stock/procurable		
		See introduction on availability codes for additional information.		

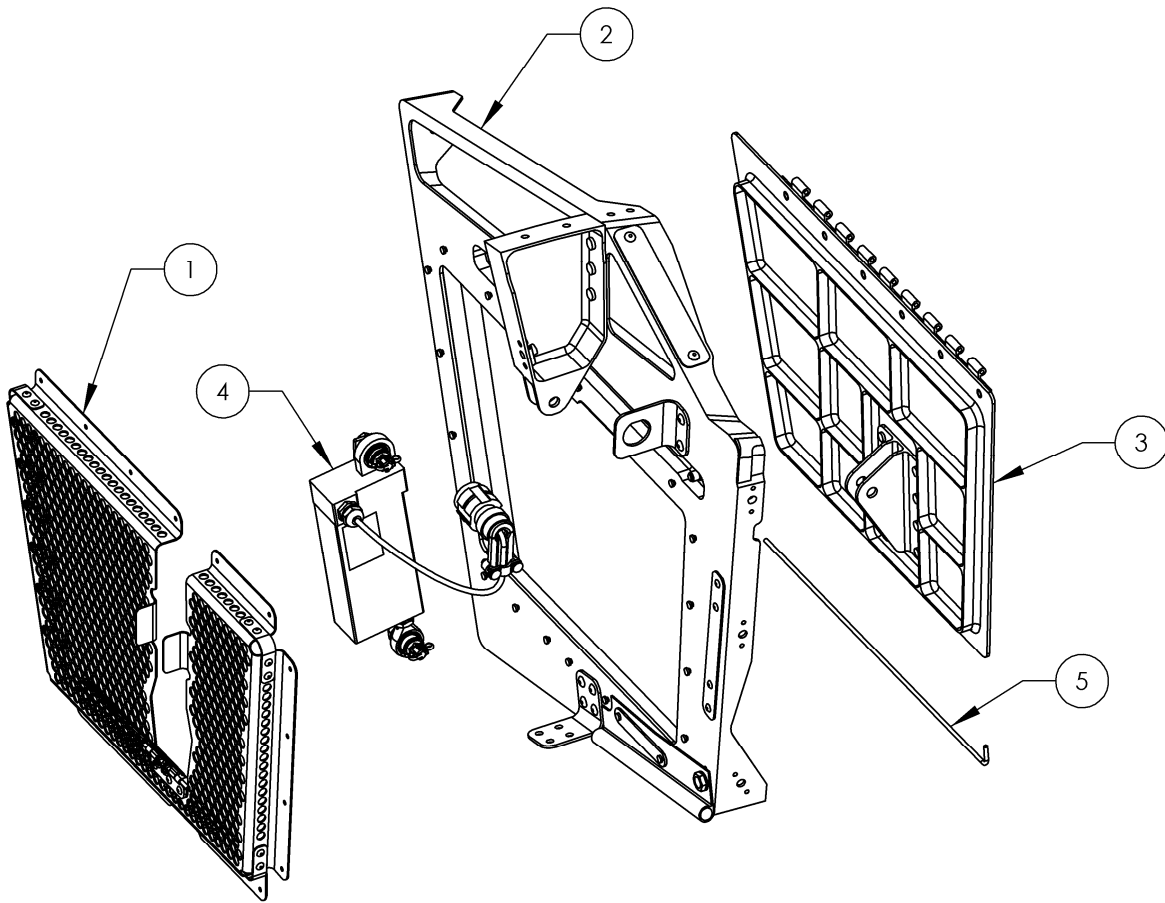

**Figure A-2: Bypass Structural Assy**  
(118100-101 Shown, 118100-102 opposite)

INDEX NUMBER	PART NUMBER	ITEM NAME	UNIT PER ASSY	A V A I L
	118100-101	FIGURE A-2: Bypass Structural Assy  Assy - Side Closeout	REF	
1	N/A	Bypass Screen Assy (See Figure A-5 for breakdown)	1	
2	N/A	Bypass Structural Sub-Assy (See Figure A-3 for breakdown)	1	
3	N/A	Bypass Door Assy (See Figure A-6 for breakdown)	1	
4	N/A	Actuator Mechanism (See Figure A-4 for breakdown)	1	
5	118705-201	Pin	1	P
<b>AVAIL CODE DEFINITION</b>				
P           Procurable NP         Non Procurable SP         Normal stock/procurable				
See introduction on availability codes for additional information.				

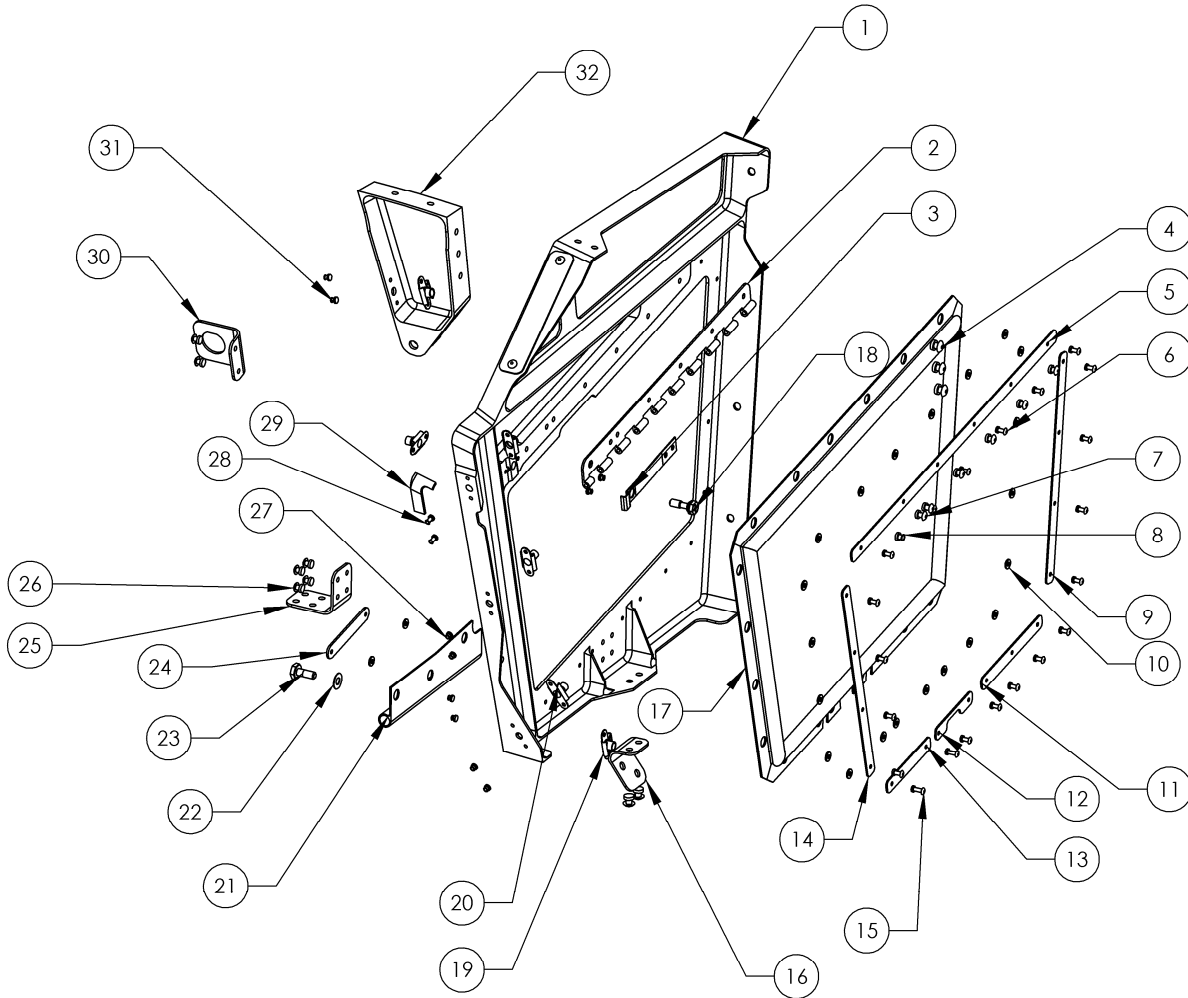
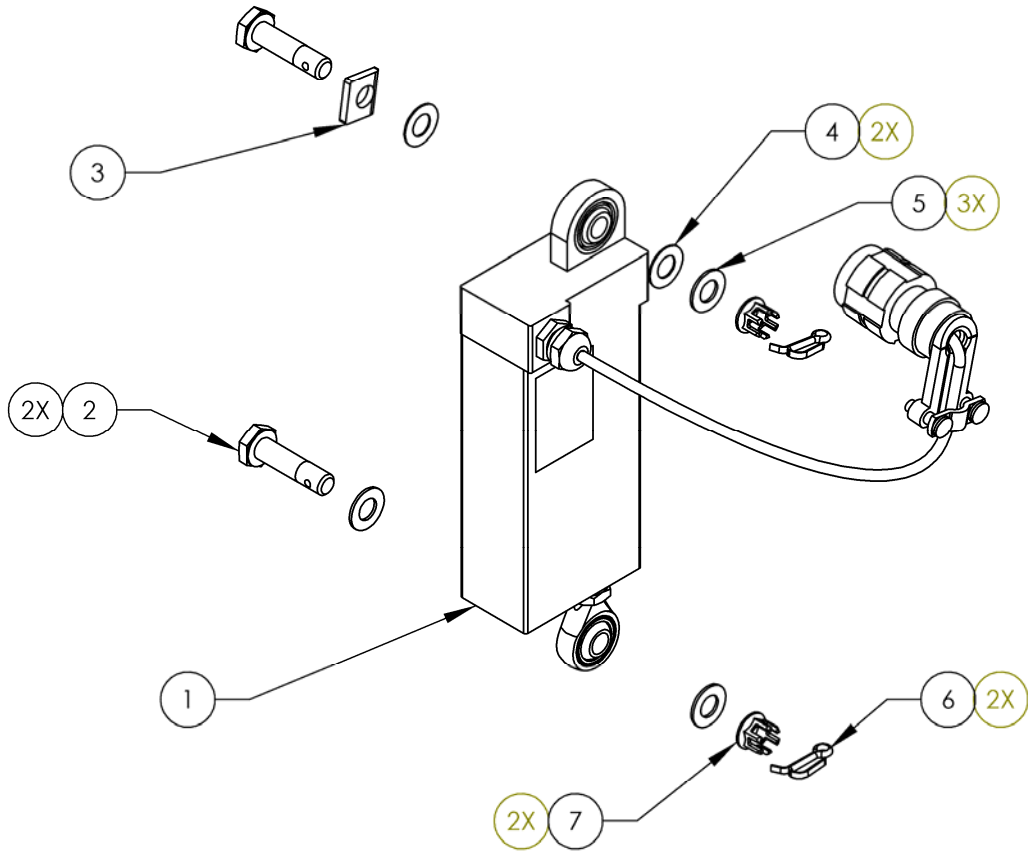

**Figure A-3: Bypass Structural Sub-Assy**



INDEX NUMBER	PART NUMBER	ITEM NAME	UNIT PER ASSY	AVALI
		FIGURE A-3: Bypass Structural Sub-Assy		
		Assy - Structure	REF	
1	118150-201/-202	Structure Sub-Assy	1	NP
2	118252-201/-202	Assy - Bypass Door (See Figure A-6)	1	P
3	118159-201	Retainer - Hinge Pin	1	SP
4	MS20470AD5-6	Rivet	1	SP
5	118111-201	Retainer - Seal, Door	1	P
6	MS20470AD3-5-5	Rivet	19	SP
7	MS20470AD4-5	Rivet	10	SP
8	NAS1097AD4-5	Rivet	1	P
9	118112-201	Retainer - Seal, Door	1	P
10	NAS1149DN332J	Washer	23	SP
11	118115-201	Retainer - Seal, Door	1	P
12	118114-201	Retainer - Seal, Door	1	P
13	118116-201	Retainer - Seal, Door	1	P
14	118110-201	Retainer - Seal, Door	1	P
15	MS20470AD3-6-5	Rivet	2	SP
16	118262-201/-202	Support - Closure, Side	1	P
17	118240-201/-202	Assy - Seal, Door, Bypass	1	P
18	WES7900-10-A-10	Captive bolt	1	P
19	MS21059L3	Platenut	2	SP
20	NAS1870-3-3	Platenut	3	SP
21	118103-201/-202	Seal - Closeout, FWD	1	P
22	NAS1149C316R	Washer	1	SP

Fig A-3 Bypass Structural Sub-Assy (Cont.)				
23	NAS6203-3	Bolt	1	SP
24	118104-201	Retainer - Seal, Closure	1	P
25	118261-201	Support - Closure, Side, 90 Deg	1	P
26	MS20470AD4-5	Rivet	10	SP
27	NAS1097AD3-3-5	Rivet	8	SP
28	NAS1097AD3-5	Rivet	2	SP
29	118310-201/-202	Seal - Closeout, INBD	1	P
30	118405-201	Bracket - Disconnect, Actuator	1	P
31	NAS1097AD3-4	Rivet	6	SP
32	118251-201/-202	Support - Actuator	1	P
<b>AVAIL CODE DEFINITION</b>				
P           Procurable				
NP         Non Procurable				
SP         Normal stock/procurable				
See introduction on availability codes for additional information.				



**Figure A-4: Actuator Mechanism**

INDEX NUMBER	PART NUMBER	ITEM NAME	UNIT PER ASSY	AVAIL
		FIGURE A-4: Actuator Mechanism		
	118600-101	Actuator Mechanism	REF	
1	118113-201	Actuator	1	P
2	NAS6204-10D	Bolt	2	SP
3	118605-201	Spacer - Actuator, Mechanism	1	P
4	NAS1149C0416R	Washer	2	SP
5	NAS1149C0432R	Washer	3	SP
6	NASM24665-235	Cotter Pin	2	SP
7	MS14144L4	Nut	2	SP
		<b>AVAIL CODE DEFINITION</b>		
		P           Procurable		
		NP         Non Procurable		
		SP         Normal stock/procurable		
		See introduction on availability codes for additional information.		

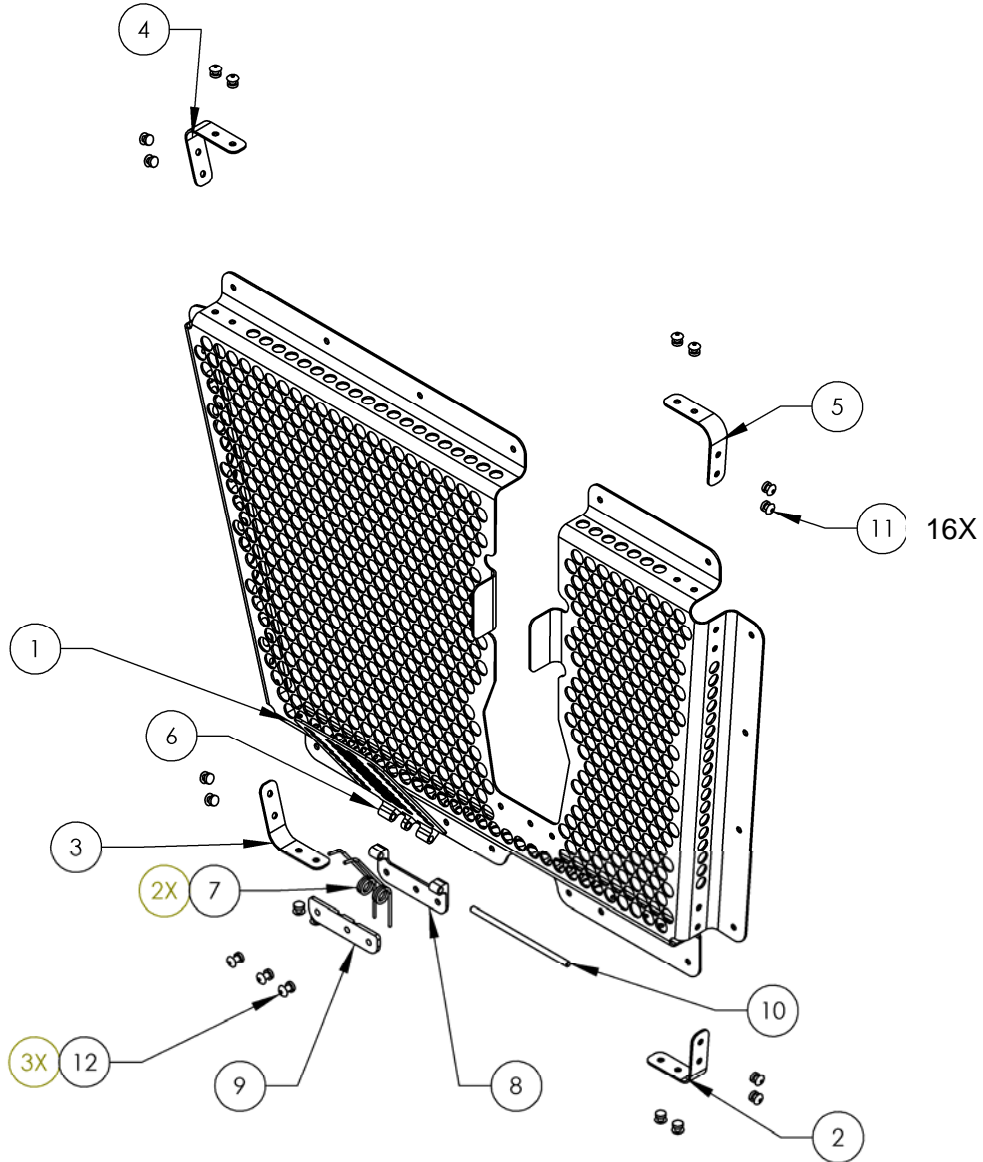

**Figure A-5: Bypass Screen Assembly**  
(118170-101 shown, 118170-102 opposite)

INDEX NUMBER	PART NUMBER	ITEM NAME	UNIT PER ASSY	A V A I L
		FIGURE A-5: Bypass Screen Assembly		
	118170-101/-102	Assy - Screen, Bypass	REF	
1	118105-201/-202	Screen - Bypass	1	P
2	118118-201	Angle - Screen, LWR FWD	1	P
3	118119-201	Angle - Screen, LWR AFT	1	P
4	118120-201	Angle - Screen, UPR AFT	1	P
5	118121-201	Angle - Screen, UPR FWD	1	P
6	118161-201	Screen - Trap Door		P
7	118162-201	Spring - Hinge	2	P
8	118163-201	Retainer - Spring, Screen	1	P
9	118164-201	Spacer - Spring, Hinge	1	P
10	A-A55486-2212	Pin	1	P
11	MS20470AD3-3-5	Rivet	16	SP
12	MS20470AD3-4-5	Rivet	3	SP
		<b>AVAIL CODE DEFINITION</b>		
		P           Procurable		
		NP         Non Procurable		
		SP         Normal stock/procurable		
		See introduction on availability codes for additional information.		

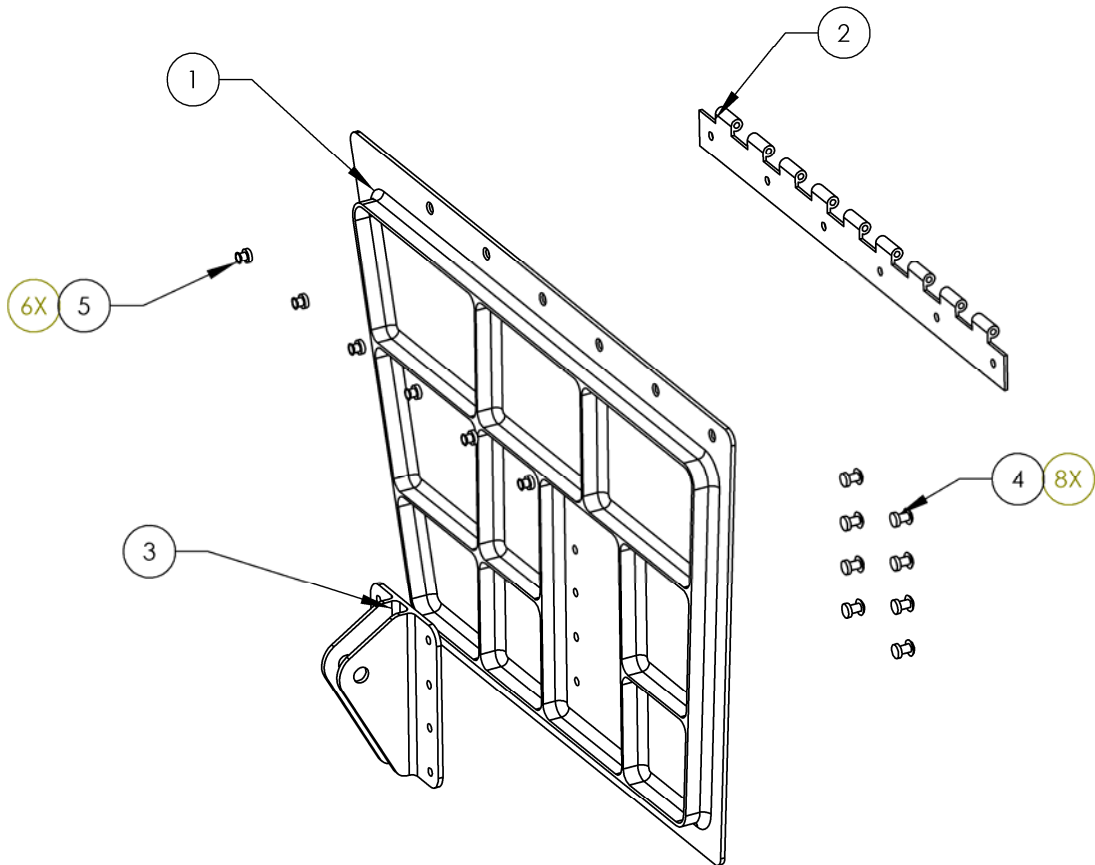

**Figure A-6: Bypass Door Assembly**  
(118500-101 shown, 118500-102 opposite)

INDEX NUMBER	PART NUMBER	ITEM NAME	UNIT PER ASSY	A V A I L
	118500-101/-102	FIGURE A-6: Bypass Door Assembly Assy - Door, Bypass	REF	P
1	118501-201/-201	Door - Bypass	1	P
2	118502-201	Hinge Half - Bypass Door	1	P
3	118504-201	Support - Actuator, Door Attach	1	P
4	MS20470AD4-6	Rivet	8	SP
5	NAS1097AD4-5	Rivet	6	SP
<p><b>AVAIL CODE DEFINITION</b></p> <p>P           Procurable NP         Non Procurable SP         Normal stock/procurable</p> <p>See introduction on availability codes for additional information.</p>				



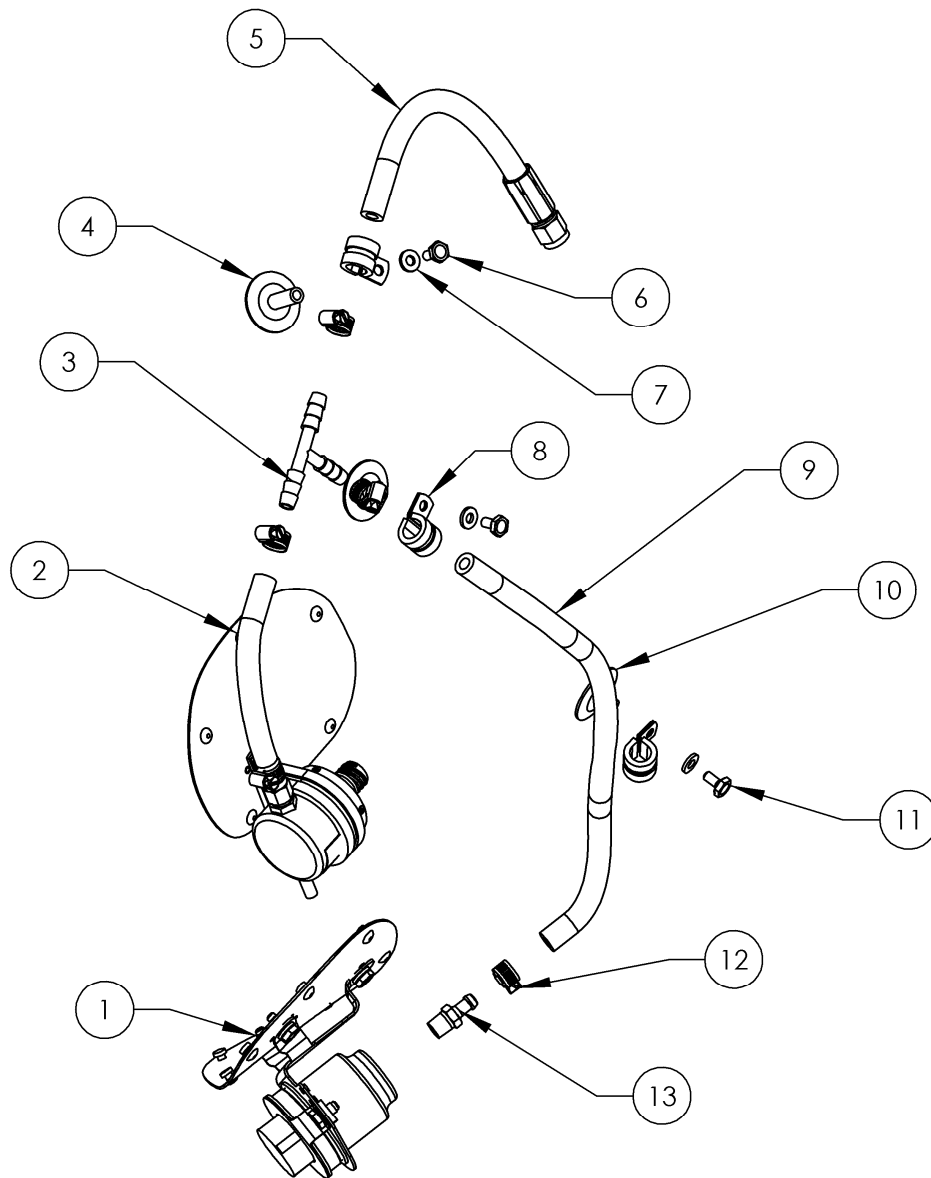

**Figure A-7: FMA & Delta P Assembly**  
(R/H shown, L/H opposite)

INDEX NUMBER	PART NUMBER	ITEM NAME	UNIT PER ASSY	AVAIL
		FIGURE A-7: FMA & Delta P Assy		
	N/A	FMA & Delta P Assy	REF	
1	See Fig A-9	Filter Maintenance Aid Assy	1	P
2	See Fig A-8	Differential Pressure Switch Assy	1	SP
3	0715-015	Tee Fitting	1	SP
4	CB3001CR3-16	Standoff	1	P
5	118245-101	Hose Assy	1	P
6	NAS6203-2	Bolt	1	SP
7	NAS1149D0363J	Washer	3	SP
8	MS21919WDG7	Clamp	3	SP
9	118213-201	Hose	1	P
10	CB3001CR3-8	Standoff	2	P
11	NAS6203-1	Bolt	2	SP
12	3604	Hose Clamp	4	P
13	1537	Hose Adapter	1	P
		<b>AVAIL CODE DEFINITION</b>		
		P           Procurable		
		NP         Non Procurable		
		SP         Normal stock/procurable		
		See introduction on availability codes for additional information.		

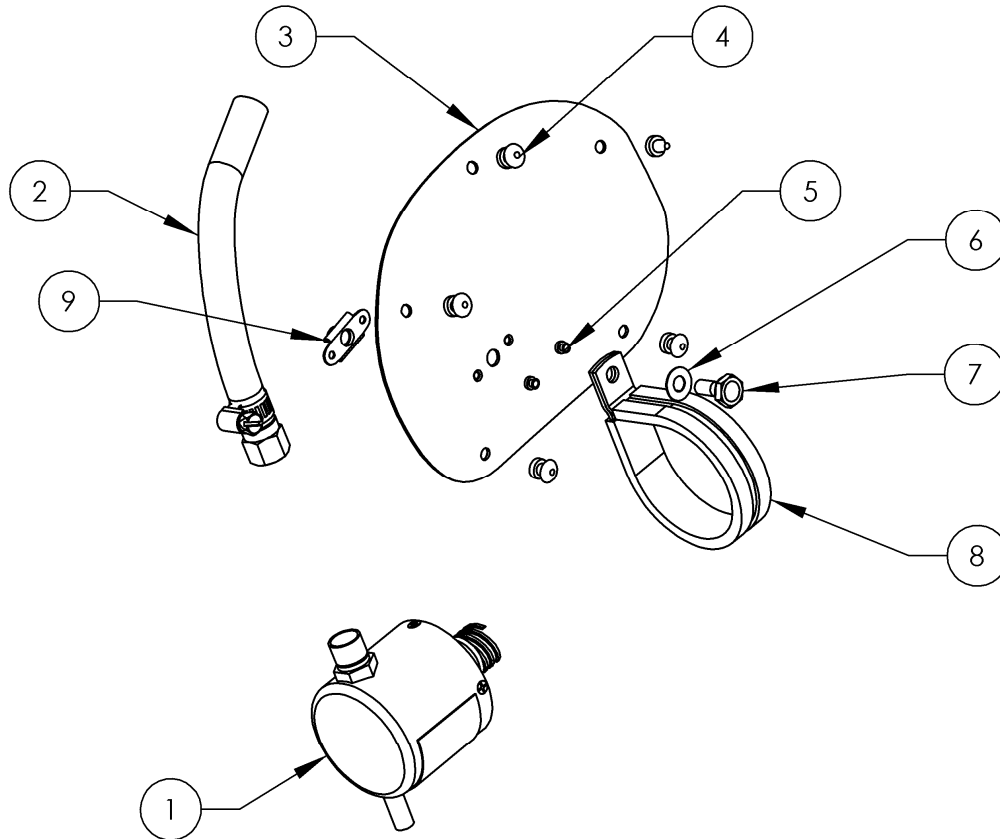

**Figure A-8: Differential Pressure Assembly**

INDEX NUMBER	PART NUMBER	ITEM NAME	UNIT PER ASSY	AVAIL
		FIGURE A-8: Differential Pressure Assembly		
	N/A	Differential Pressure Assy	REF	
1	118265-201	Delta-P Sensor	1	P
2	118235-101	Assy - Tube, Delta-p, FWD	1	P
3	118202-201/-202	Cover - UPR (Used on 118004-101)	1	P
4	MS20426AD5-6	Rivet (Used on 118004-101)	5	SP
5	NAS1097AD3-5	Rivet (Used on 118004-101)	2	SP
6	NAS1149D0363J	Washer	1	SP
7	NAS6203-3	Bolt	1	SP
8	MS21919WDG28	Clamp	1	SP
9	MS21059L3	Platenut (Used on 118004-101)	1	SP
10	CB3001CR3-8	Standoff (Used on 118004-103, not shown)	1	P
		<b>AVAIL CODE DEFINITION</b>		
		P           Procurable		
		NP         Non Procurable		
		SP         Normal stock/procurable		
		See introduction on availability codes for additional information.		

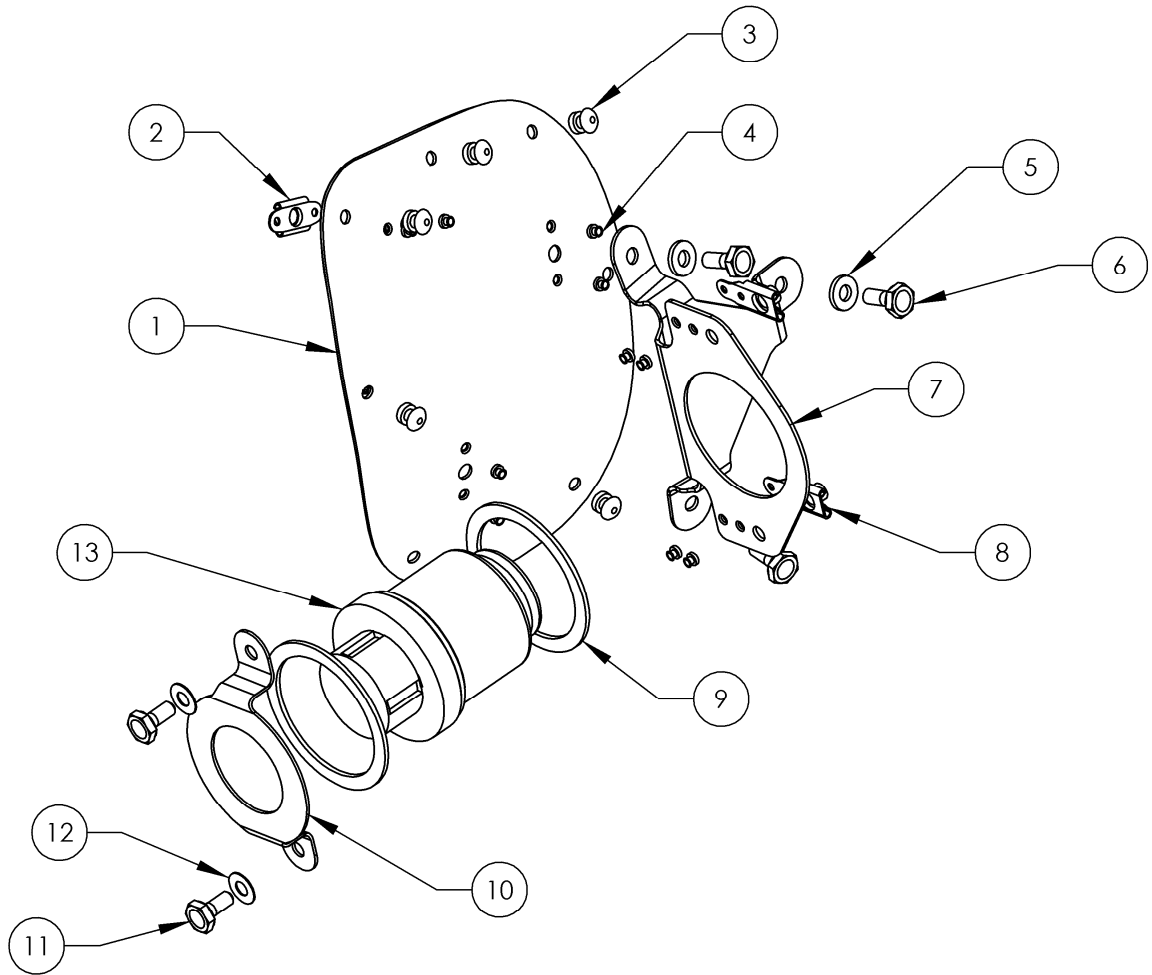

**Figure A-9: FMA Assembly**

INDEX NUMBER	PART NUMBER	ITEM NAME	UNIT PER ASSY	AVAIL
		FIGURE A-9: Filter Maintenance Aid Assembly		
	N/A	Filter Maintenance Aid Assy	REF	
1	118203-102/-202	Cover - LWR (Used on 118004-101)	1	P
2	MS21059L3	Platenut (Used on 118004-101)	1	SP
3	MS20426AD5-6	Rivet (Used on 118004-101)	7	SP
4	NAS1097AD3-5	Rivet (Used on 118004-101)	10	SP
5	NAS1149D0363J	Washer	3	SP
6	NAS6203-3	Bolt	3	SP
7	118207-201	Retainer	1	P
8	MS21061L3	Platenut	2	SP
9	118212-201	Cushion	2	P
10	118204-201/-202	Mount - Indicator, Maintenance	1	P
11	NAS6203-2	Bolt	2	SP
12	NAS1149D0316J	Washer	2	SP
13	104441-203	Filter Maintenance Aid	1	P
14	CB3001CR3-8	Standoff (Used on 118004-103, not shown)	3	p
		<b>AVAIL CODE DEFINITION</b>		
		P           Procurable		
		NP         Non Procurable		
		SP         Normal stock/procurable		
		See introduction on availability codes for additional information.		

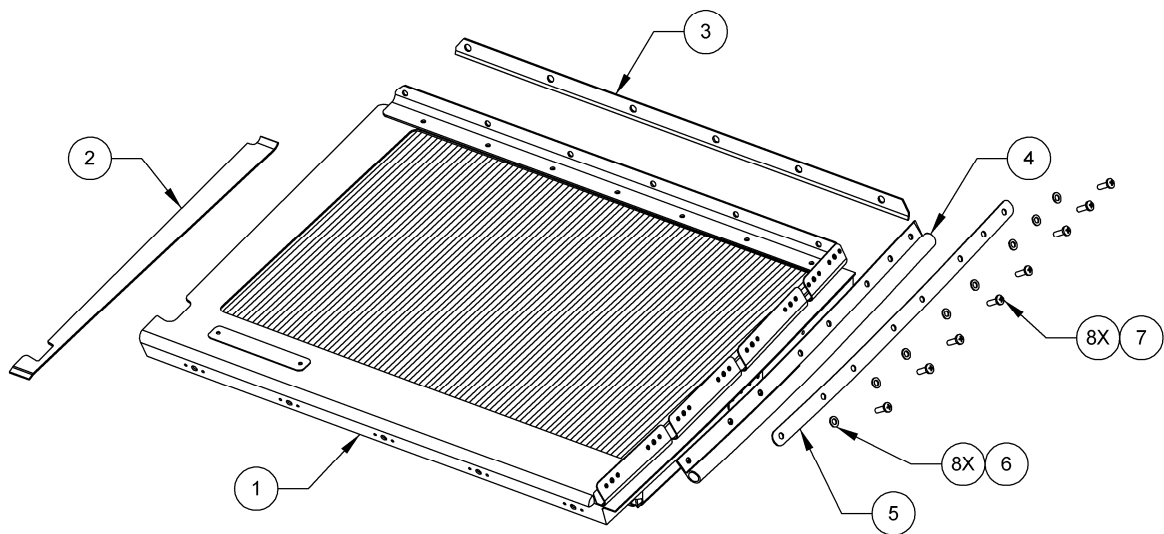

**Figure A-10: Upper Filter Assembly**  
(118300-101 shown, 118300-102 opposite)

INDEX NUMBER	PART NUMBER	ITEM NAME	UNIT PER ASSY	AVAIL
		FIGURE A-10: Upper Filter Assembly		
	118300-101/-102	Assy - Filter, UPR	1	P
1	118390-101/-102	Sub-Assy - Filter, UPR	1	P
2	118309-201/-202	Seal - Top Filter, INBD	1	P
3	118316-201/-202	Seal - Top Filter, AFT	1	P
4	118308-201/-202	Seal - Top Filter, OUTBD	1	P
5	118314-201/-202	Strap - Top Filter, OUTBD	1	P
6	NAS620-10L	Washer	8	SP
7	MS27039C0808	Bolt	8	SP
		<b>AVAIL CODE DEFINITION</b>		
		P           Procurable		
		NP         Non Procurable		
		SP         Normal stock/procurable		
		See introduction on availability codes for additional information.		



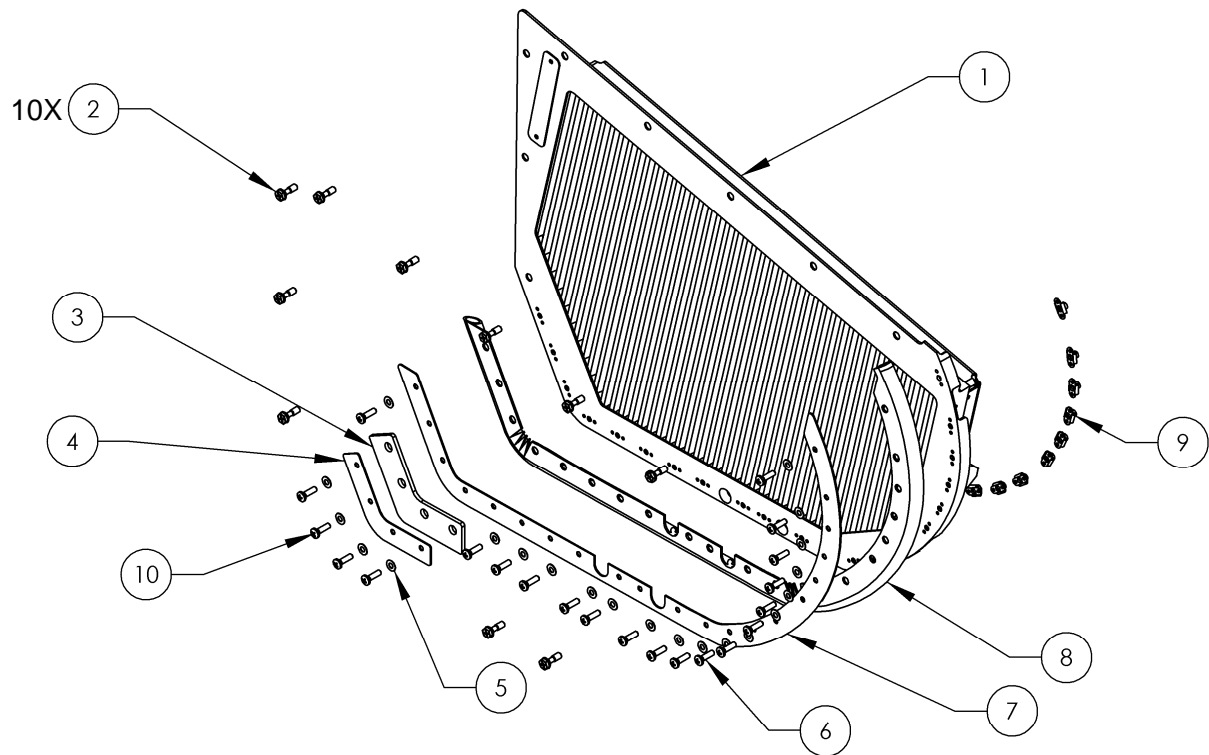

**Figure A-11: Forward Filter Assembly**  
(118350-101 shown, 118350-102 opposite)

INDEX NUMBER	PART NUMBER	ITEM NAME	UNIT PER ASSY	AVAIL
		FIGURE A-11: Forward Filter Assembly		
	118350-101/-102	Assy - Filter, FWD	1	P
1	118340-101/-102	Sub-Assy - Filter, FWD	1	P
2	WES7900-10-A-10	Captive Bolt	10	P
3	118366-201	Seal - Filter, FWD, Corner	1	P
4	118365-201	Retainer - Seal, FWD, Corner	1	P
5	NAS1149DN816J	Washer	21	SP
6	MS27039C0809	Bolt	17	SP
7	118357-201	Retainer - Seal, Front Filter	1	P
8	118356-201/-202	Seal - Front Filter	1	P
9	MS21075L08N	Platenut	21	SP
10	MS27039C0810	Bolt	4	SP
11	NAS1097AD3-4	Rivet (Not Shown)	42	SP
		<b>AVAIL CODE DEFINITION</b>		
		P           Procurable		
		NP         Non Procurable		
		SP         Normal stock/procurable		
		See introduction on availability codes for additional information.		

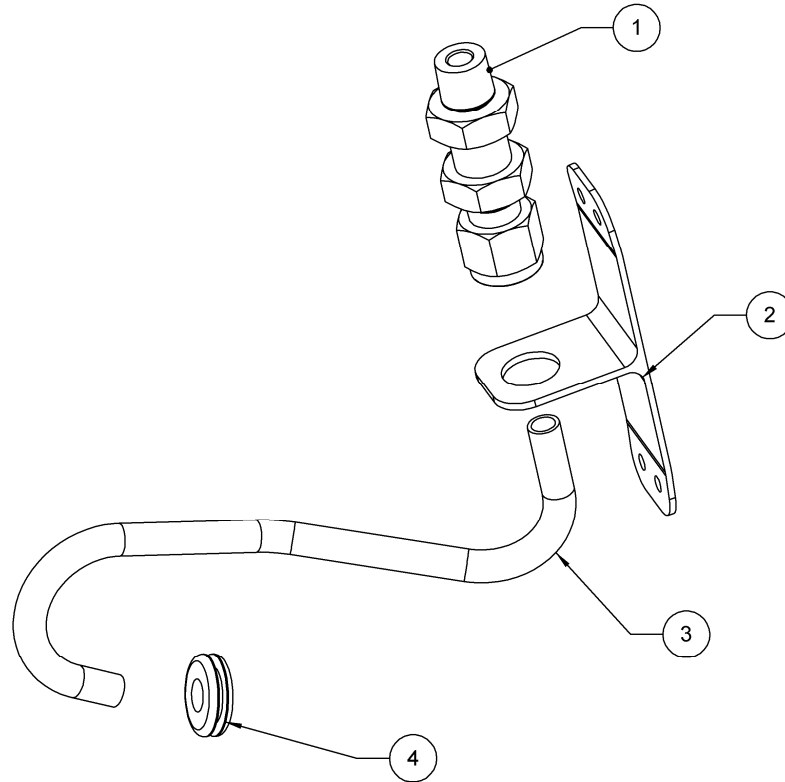

**Figure A-12: FMA Interface Assembly**

INDEX NUMBER	PART NUMBER	ITEM NAME	UNIT PER ASSY	AVAIL
		FIGURE A-12: FMA Interface Assy		
	N/A	Assy - FMA Interface	1	P
1	SS-400-61-4AN	Bulkhead Fitting	1	P
2	118209-09-201	Support - FMA Tube	1	P
3	118210-201/-202	Tube - FMA, Inlet	1	P
4	MS35489-6	Grommet	1	P
<b>AVAIL CODE DEFINITION</b>				
P           Procurable				
NP         Non Procurable				
SP         Normal stock/procurable				
See introduction on availability codes for additional information.				

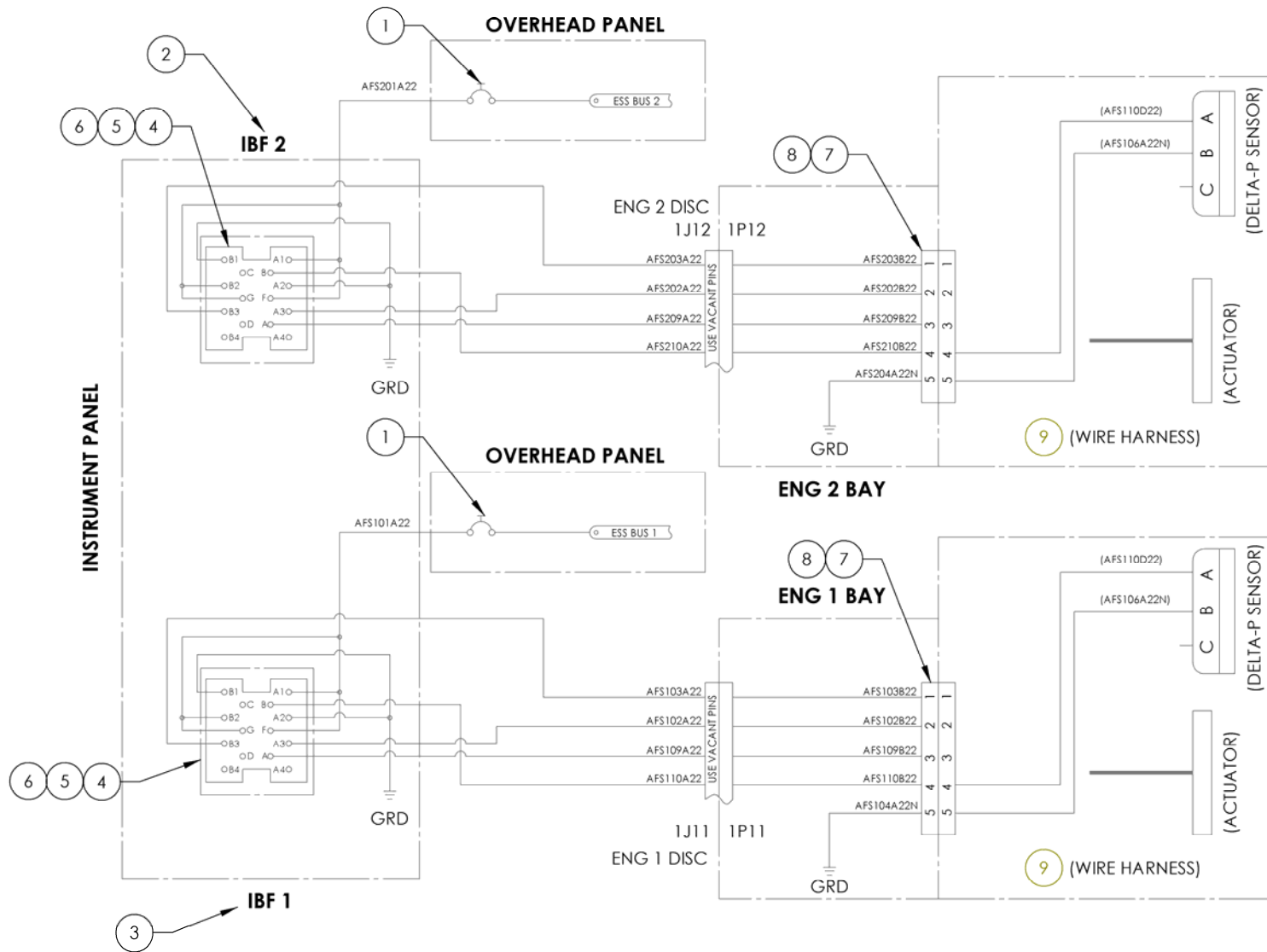

Figure A-13: Electrical Installation and Schematic

INDEX NUMBER	PART NUMBER	ITEM NAME	UNIT PER ASSY	A V A I L
		FIGURE A-13: Electrical Installation and Schematic		
	N/A	Electrical System - IBF and Aircraft Interface	REF	
1	MS22073-3	Circuit Breaker	2	P
2	118401-202	Placard	2	P
3	118401-201	Placard	2	P
4	LED-42-15-KB-36066	Switch/Indicator	2	P
5	18-200	Quick Connector	2	P
6	MS39029/22-192	Pin	20	P
7	D38999/20KA35SN	Electrical Connector	2	P
8	M85049/38S9S	Backshell	2	P
9	118400-101	Wire Harness	2	P
		<b>AVAIL CODE DEFINITION</b>		
		P           Procurable		
		NP         Non Procurable		
		SP         Normal stock/procurable		
		See introduction on availability codes for additional information.		