



CCI Thermal
Technologies INC.
Heating and Filtration Solutions



Fastrax[™]
Track and Switch Heaters

Installation & Operations Manual
G Series - Control Panel Package

Contents

Equipment Inspection

Review Equipment Paperwork.....	4
Bill Of Material	4
Pick Ticket Example	5
Equipment Check	6

System Layout

Layout Guidelines.....	7
Single Stand Alone Switch With Frog	8
Crossover No. 20/24 Switches With Frogs	9
No. 9, 10 Or 11 Standard Switch Size - All Tie Styles.....	10
No. 14, 15 Or 16 Standard Switch Size - All Tie Styles	11
No. 20 / 24 Standard Switch Size - All Tie Styles	12
Spring Frog & Movable Point Frog Heating Layout	13

Control Panel Installation

Assembling Fastrax® FCSA Panel Support Structure.....	14
Installing Fastrax® FCSA Panel	15
Installing Wire Conduit Raceway To Panel	15
Installing Fastrax® Aerial Snow Sensor & Support Mast.....	16

Junction Box Installation

Junction Box Placement	17
Direct Burial Cable & Conduit Trenching	17
Direct Burial Cable , Conduit & Junction Box Installation	18

SwitchBlade® Heater Installation

SwitchBlade® Heaters (Field Side Running Rail) Switches Up To No. 16	19
SwitchBlade® Heaters (Field Side Running Rail) Switches No. 20 - 24.....	21
Heater Power Wire To Junction Box.....	22
SwitchBlade® Heater(s) For Gauge Side Of The Moving Rail	23
SwitchBlade® Heater(s) For Spring Frog (Spring Frog Channel Style).....	24
SwitchBlade® Heater(s) For Spring Frog (Retrofit Style)	25
Movable Point Frog - Switches No. 20 - 24	26

Crib Heater Installation

All Switch & Frog Systems.....	27
--------------------------------	----

System Wiring

Control Panel Wiring.....	28
Control Panel Disconnect Feeder Wiring - Stand Alone/Extension Panels	28
Control Panel SwitchBlade® Heater Wiring - Stand Alone/Extension Panels Only.....	29
Master Control Wiring	29
FAS1A Aerial Snow Sensor Wiring	30
FGSP1A Ground Level Sensor Wiring At Panel	30

System Wiring Diagrams

Stand Alone Control Panel Wiring Diagram (1) No. 9, 10, Or 11 Switch & Spring Frog Heating System.....	31
Stand Alone Control Panel Wiring Diagram (2) No. 9, 10, Or 11 Switch & Spring Frog Heating System	32
Stand Alone Control Panel Wiring Diagram (1) No. 14, 15, Or 16 Switch & Spring Frog Heating System	33
Stand Alone Control Panel Wiring Diagram (1) No. 20 Or 24 Switch & Spring Frog Heating System	34
Stand Alone Control Panel Wiring Diagram (1) No. 20 Or 24 Switch & Movable Point Frog Heating System	35
Master Control Panel Wiring Diagram Up To (4) Fastrax® Extension Panels	36
Extension Control Panel Wiring Diagram (1) No. 20 Or 24 Switch & Movable Point Frog Heating System	37
Master Control Panel Wiring Diagram Up To (8) Fastrax® Extension Panels	38
Extension Control Panel Wiring Diagram (1) No. 9, 10, Or 11 Switch & Spring Frog Heating System	40
Extension Control Panel Wiring Diagram (2) No. 9, 10, Or 11 Switch & Spring Frog Heating System	41
Extension Control Panel Wiring Diagram (1) No. 14, 15, Or 16 Switch & Spring Frog Heating System	42
Extension Control Panel Wiring Diagram (1) No. 20 Or 24 Switch & Movable Point Frog Heating System	43
Junction Box Connections	44
Junction Box Heater Connections	45
FGSP1A Ground Snow Sensor Wiring At FJAM200SUP Junction Box.....	48

Control Panel General Equipment Procedures

Master & Stand Alone Panel FDC-6/FDC-7 Adjustment Instructions	55
Stand Alone Control Panel (Automatic Operation)	55
Stand Alone Control Panel (Manual Operation).....	56
Additional Features Stand Alone Control Panel.....	56
Master/Extension Control Panels (Automatic Operation)	57
Master/Extension Control Panels (Manual Operation)	57
Additional Features Master/Extension Control Panel	58
Options Available For The Master/Extension Control Panel	58
Maintenance	58
SwitchBlade® Heating.....	59
Spring Frog Heating.....	59
Movable Point Frog Heating	60

Procedures

General Operation	60
Installation Procedure.....	60
Maintenance Procedure.....	61

A. EQUIPMENT INSPECTION

A.1 REVIEW EQUIPMENT PAPERWORK

1. Identify the switch and frog sizes to be heated on your project.
2. Ensure that the Pick Ticket (list of Fastrax® heating equipment and accessories) provided with the shipment, matches the items listed on the complete Bill of Material for your project.
3. Notify your supervisor, purchasing department or Fastrax® of any missing or damaged parts.

A.2 BILL OF MATERIAL

Table A.2-1 provides the scope of Bill of Materials available for standard switch and frog layouts and parts packages. A custom Bill of Material for special layouts is also available. A copy of the Bill of Material can be acquired by contacting your supervisor or CCI Thermal Fastrax®.

Table A.2-2 details a sample Bill of Material listing, refer to your company Bill of Material for exact system parts.

Table A.2-1 - Bill of Material by Standard Application

SWITCH TYPE			BILL OF MATERIAL - APPLICATION
No. 9	No. 10	No. 11	
✓	✓	-	Power Operated Turnout
✓	✓	-	Power Operated Turnout with Spring Rail Frog
✓	✓	✓	Spring Rail Frog
-	-	✓	Power Operated Turnout
-	-	✓	Power Operated Turnout with Spring Rail Frog
No. 14	No. 15	No. 16	
✓	✓	✓	Power Operated Turnout
✓	✓	✓	Power Operated Turnout with Spring Rail Frog
✓	✓	✓	Spring Rail Frog
No. 20	No. 24		
✓	✓		Power Operated Turnout
✓	✓		Power Operated Turnout with Spring Rail Frog
✓	✓		Spring Rail Frog
✓	✓		Power Operated Turnout with Power Operated Movable Point Frog
No. 30			
✓			Power Operated Turnout with Power Operated Movable Point Frog
Automatic Gas Snow Control Package			
Platform Heating Package			
Scanner and Dragging Equipment Detection Heating Package			


Table A.2-2 - Bill of Material Example

(2) No. 20 / 24 Power Operated Turnout with (2) Power Operated Movable Point Frog Hollow Metal Ties Master Control with Extension Panels		
Quantity Required	Fastrax® Part No.	Description
1	FCM4	Fastrax® Master Control Panel - Controls maximum of 4 Extension panels. Minimum 10 AMP, 120V, 1-phase required. Enclosure size: 36" H X 30" W X 10" D.
2	GDSM1-12148200	Fastrax® Extension Combination Switch & Movable Point Frog Control Panel - Controls heaters for (1) No. 20 switch with crib and moving rail heaters and (1) No. 20 movable point frog. 48 kW maximum capacity, 200 Amps, 240V, 1-phase disconnect. Enclosure size: 36" H X 30" W X 10" D.
3	FCSA3630U	Fastrax® Control Panel Support Assembly - 36" H X 30" W overall panel size. 4" square vertical support risers. Includes (2) 4" PVC raceways.
8	FSR32420	Fastrax® SwitchBlade® Rail Heater - 5,800W total, 240V. 300W per foot of active heater length. 20 ft overall length. (11) FRB600 Spring tension clamp kits included. No drilling required.
4	FSE32408	Fastrax® SwitchBlade® Rail Heater - 2,200W total, 240V. 300W per foot of active heater length. 8 ft overall length. (5) XTC-0193 Anchor spring tension clamp kits included. No drilling required.
12	FCH152409	Fastrax® Crib Heater Assembly - 1,350W total, 240V. 150W per foot of platform length. 8 ft L X 8" W X 2-1/2" H. Includes (4) jack-bolt clamps.
4	FSM32412	Fastrax® SwitchBlade® Heater for Movable Point Frog - 3,400W total, 240V. 300W per foot of active heater length. 12 ft overall length.
8	FSM42403	Fastrax® SwitchBlade® Heater for Movable Point Frog - 750W total, 240V. 400W per foot of active heater length. 2 ft 9" overall length.
5	FJA200SU	Fastrax® Junction Box Assembly
1	FJAM200SUP	Fastrax® Junction Box with Snow Sensor Assembly
1	FA2032	Fastrax® Installation Kit - Includes entrance glands, insulated connector blocks, liquid tight extra flexible protective conduit, flexible conduit connectors, stainless steel hose clamps, wire markers, test and tool accessories.

A.3 PICK TICKET EXAMPLE

The Pick Ticket is included with the Fastrax® product shipment. The following sample Pick Ticket details the list of Fastrax® products in a shipment. Please compare the Pick Ticket with the items listed on the Bill of Material to be sure you have all required parts for your project.

Note: The Pick Ticket may not be available if the shipment was warehoused prior to project site delivery.

 Fastrax™ Track and Switch Heaters		Pick Ticket# 003378							
1500 W. Campus Drive Littleton, CO 80120 Phone: (303) 979-7339 Fax: (303) 979-7350		<table border="1" style="width: 100%; border-collapse: collapse;"> <tr> <td style="width: 50%;">Customer ID 00001063</td> <td colspan="2">Contact</td> </tr> <tr> <td>Customer PO 123456</td> <td>Telephone</td> <td>Facsimile</td> </tr> </table>		Customer ID 00001063	Contact		Customer PO 123456	Telephone	Facsimile
Customer ID 00001063	Contact								
Customer PO 123456	Telephone	Facsimile							
Bill To: <div style="border: 1px solid black; padding: 5px; width: fit-content;"> Class 1 Railroad Company Anywhere, USA, </div>		Ship To: <div style="border: 1px solid black; padding: 5px; width: fit-content;"> Class 1 Railroad Company Anywhere, </div>							
Special Order <input type="checkbox"/> Drop Ship <input type="checkbox"/>									
Order Date 09/21/2005	Comments #20/24 Crossover w/ MPF and HST	Special Instructions Call for more information	Terms NET 30						
Ship Via BEST WAY	Date Required 09/30/2005	FOB FASTRAX	From Our Order# 003378 Salesperson John Doe						
Item#	UOM Bin Location	Required	Shipped	Description					
FCM4	EACH NONE	1	_____	Master Control Panel - Maximum 4 Slaves <i>Fastrax Master Control Panel.</i> <i>Control maximum of 4 Extension panels of any size.</i> <i>Minimum 10 Amp 120 Volt 1-phase required.</i> <i>Enclosure size: 36"H X 30"W X10"D.</i> <i>Panel Serial #: _____</i> <i>Aerial Sensor Serial: _____</i>					
GDSM1-12148200	EACH NONE	2	_____	Extension Panel-Combo. Switch & MP Frog <i>Fastrax Extension Control Panel.</i> <i>Combination Switch and Moveable Point Frog Heater Control Panel.</i> <i>1 Switch and 1 Moveable Point Frog.</i> <i>48KW maximum capacity.</i> <i>200 Amp 240 Volt 1-phase disconnect</i> <i>Control 2 switch heaters, 1 movable point frog heater,</i> <i>4 FCH152409 crib heaters.</i> <i>Enclosure size: 36"H X 30"W X10"D.</i>					
FCSA3630U	EACH NONE	3	_____	Fastrax® Panel Support Structure <i>Fastrax® control panel support structure assembly</i> <i>36 Inch high X 30 inch wide overall panel size</i> <i>4 inch square vertical support risers.</i> <i>Includes (2) 4" PVC protective raceway assemblies.</i>					
FSR32420	EACH NONE	8	_____	Fastrax® SwitchBlade® Rail Heater <i>Fastrax® SwitchBlade® Rail Heater -</i> <i>5,800W total, 240V. 300W per foot of</i> <i>active heater length. 20 ft overall length.</i> <i>(11) FRB600 Spring tension clamp</i> <i>kits included. No drilling required.</i>					
Packed By	Pulled By	Checked By	# of Cartons	Total Weight					
Date Printed 09/21/2005		1	Page # 1 of 3						

A.4 EQUIPMENT CHECK

Note: Notify your supervisor, purchasing department or Fastrax® of any missing or damaged parts.

1.0 Control Panel:

1. Using a Phillips screwdriver or Phillips driver head and power drill, remove top and sides of panel crate.



Note: Inside each stand alone or master control panel crate there is one FAS1A Aerial Snow Sensor located in a box. Keep the sensor in a safe place until the panel support and panel installation are complete.

2. Using a socket wrench, remove lag bolts from the crate.

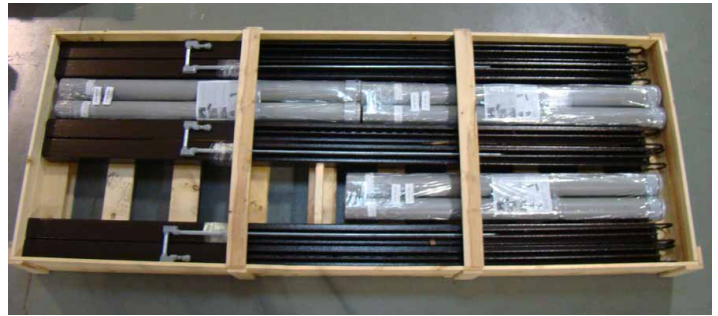


3. Open the panel and check that the nameplate information matches the Bill of Material list.



2.0 Control Panel Support:

1. Using a Phillips screwdriver, remove top and sides of panel support assembly crate.
2. Ensure that each panel support size matches the corresponding panel size.



3.0 Heating Equipment:



Figure A.4.1 - Typical Packaging

1. Unpack each heater at the project site, prior to installation.
2. Ensure the correct voltage is marked on each heater for your project.
3. Ensure the part number on each heater matches the Bill of Material for your project (refer to page 4 - A.2-1 Bill of Material and Figure A.2.2).



Figure A.4.2 - Heater part number and voltage

4. Test each heater using the 500 Volt DC scale on a standard meg ohm meter.
 - a) Connect one lead of the meg ohm meter to the metal jacket of the heater and the insulation resistance should read at least 20 meg ohms from conductor to outer meter jacket (refer to Figure A.4.3). Do not come into contact with heater while performing the meg ohm test.



Figure A.4.3 - Meg Ohms Reading

Note: If any heater does not reach 20 meg ohms, contact Fastrax® and do not install the heater.

- b) Using a standard ohm meter, connect each lead from the ohm meter to each heater lead (see Figure A.4.4).



Figure A.4.4 - Standard Ohms Reading

- c) Record the ohm readings for each heater on the "System Checkout" sheet located at the back of the manual.

4.0 Junction Box Assembly:

Ensure that each junction box has a corresponding support pedestal.

5.0 Installation Accessories:

Unpack the installation accessory kit and check that the contents matches the description on the Pick Ticket.

B. SYSTEM LAYOUT

B.1 LAYOUT GUIDELINES

1. Prior to installation of any of Fastrax® equipment, mark or tag the location for product installation.
2. Locate equipment for each switch or frog.
3. Place the equipment near the location but out of the way of cable or conduit trenching and general construction.

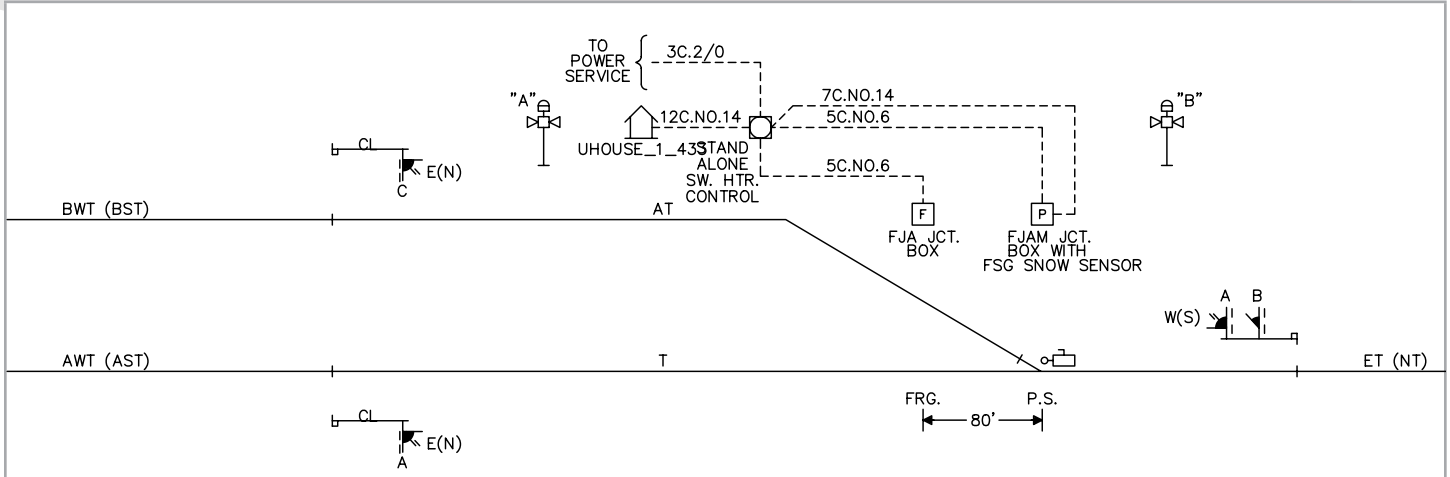


Note: For systems that are not standard sizes or grouping of equipment as covered in this manual or in Bill of Material, please contact Fastrax® or your company system standards for assistance.

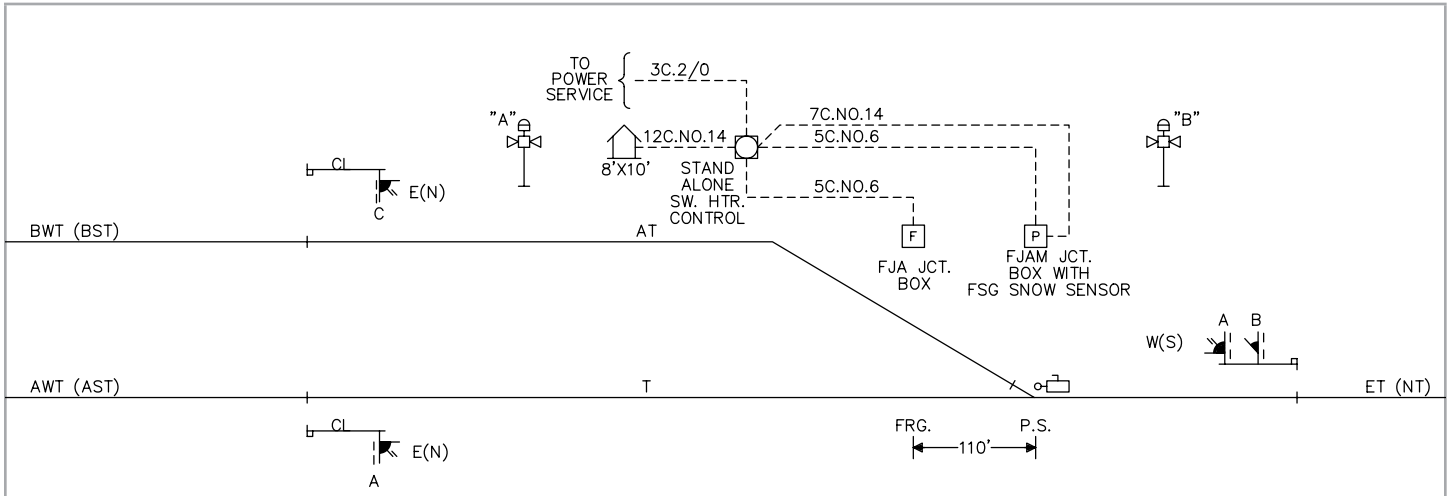
Note: Typical layouts are not to scale and are to be used for general positioning of equipment only. Review your company standards for exact equipment layout.

B.2 SINGLE STAND ALONE SWITCH WITH FROG

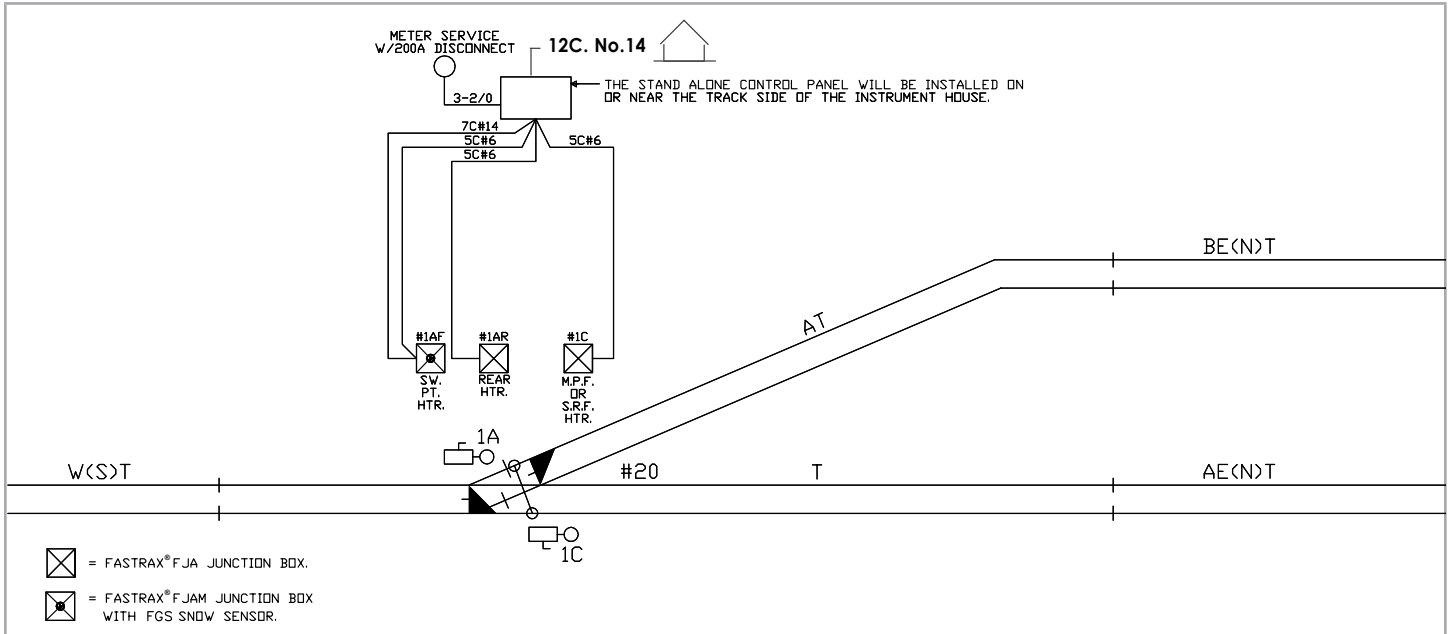
No. 9 - No. 11 Switch and Frog



No. 14 - No. 16 Switch and Frog

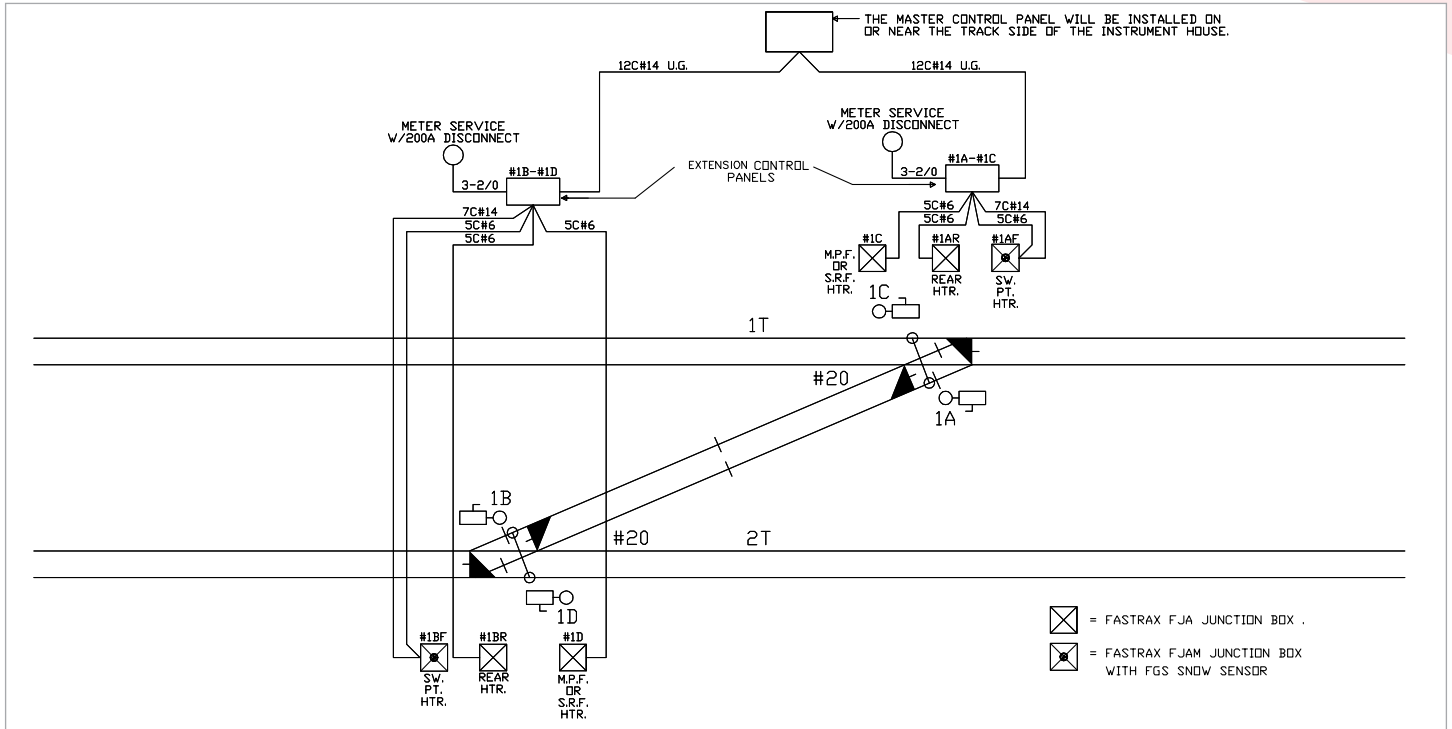


No. 20/24 Switch and Frog

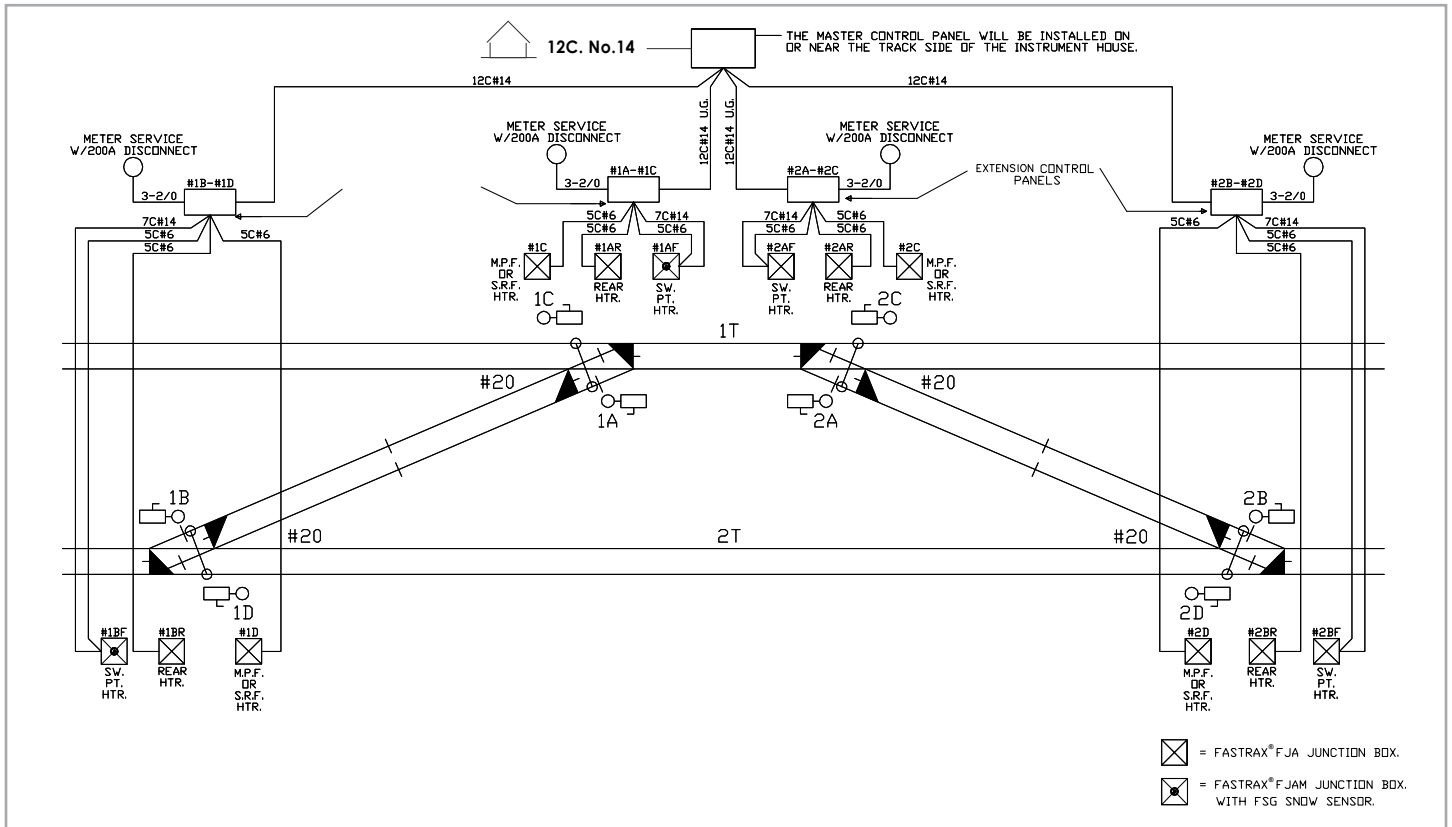


B.3 CROSSOVER NO. 20/24 SWITCHES WITH FROGS

Single Crossover No. 20 or No. 24 Switches with Frogs

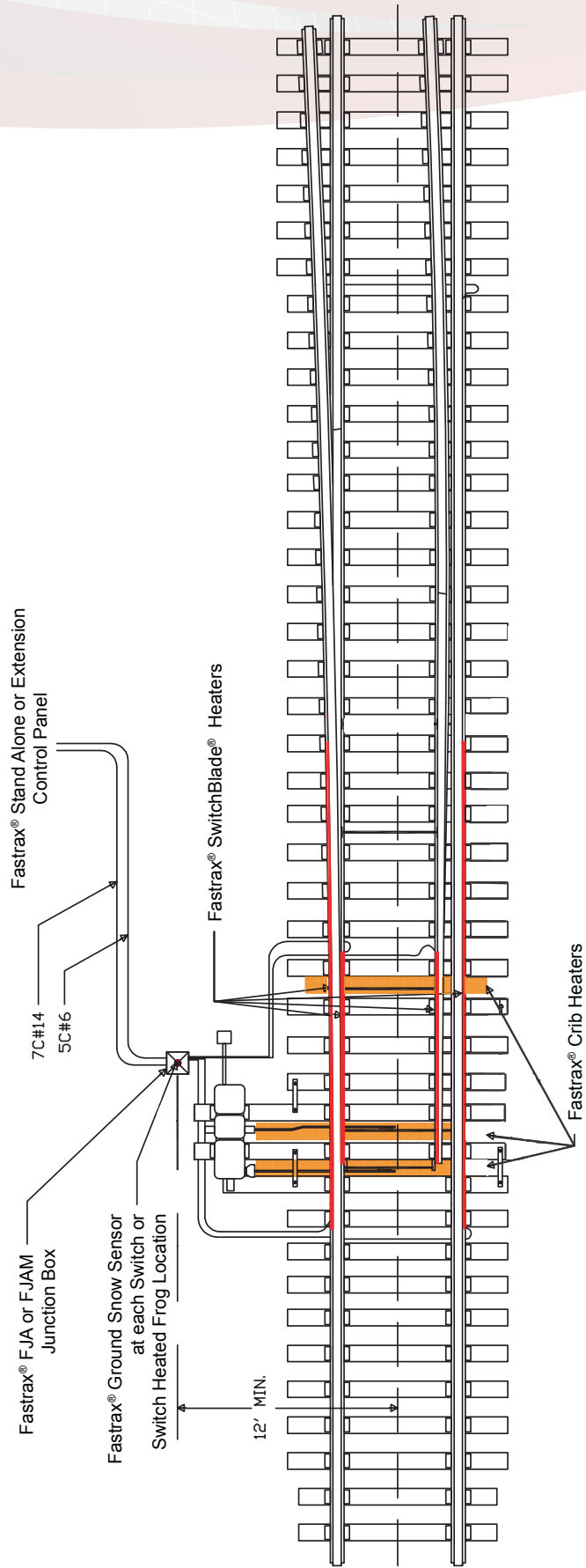


Double Crossover No. 20 or No. 24 Switches with Frogs



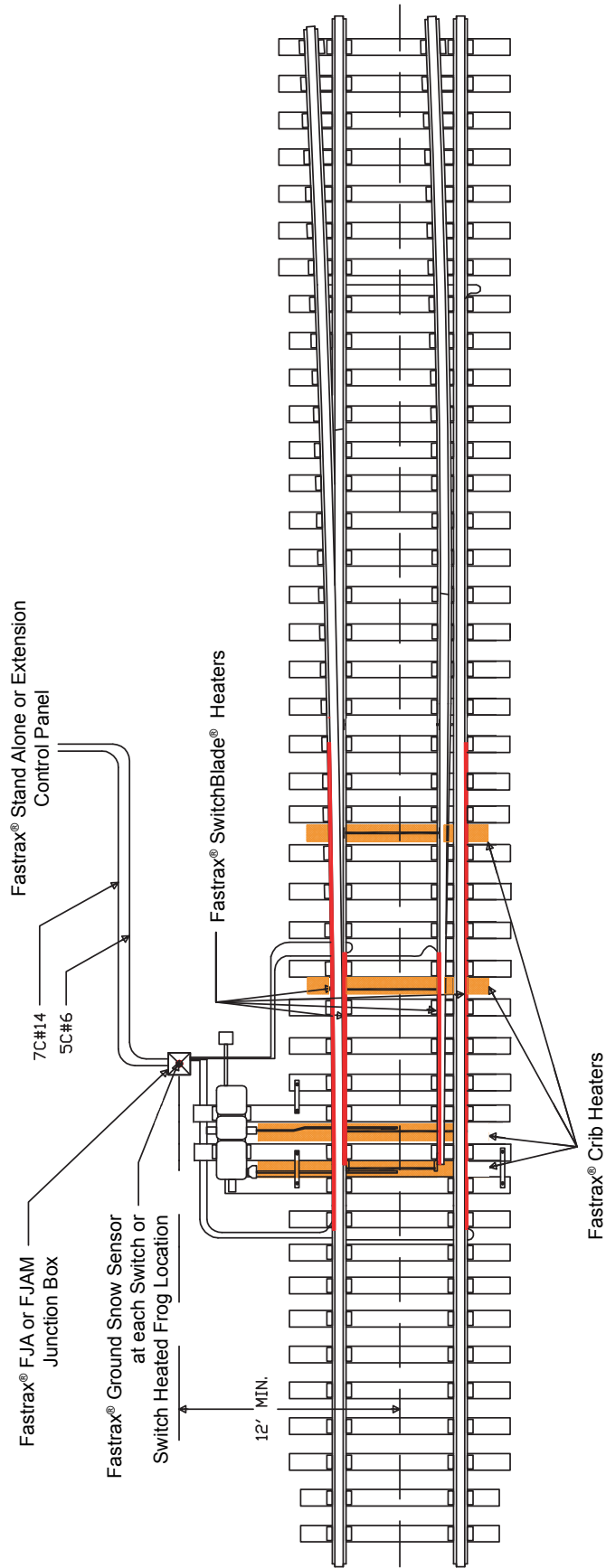
B.4 NO. 9, 10 OR 11 STANDARD SWITCH SIZE - ALL TIE STYLES

Typical layouts are not to scale and are to be used for general positioning of equipment only. Review your company standards for exact equipment layout.



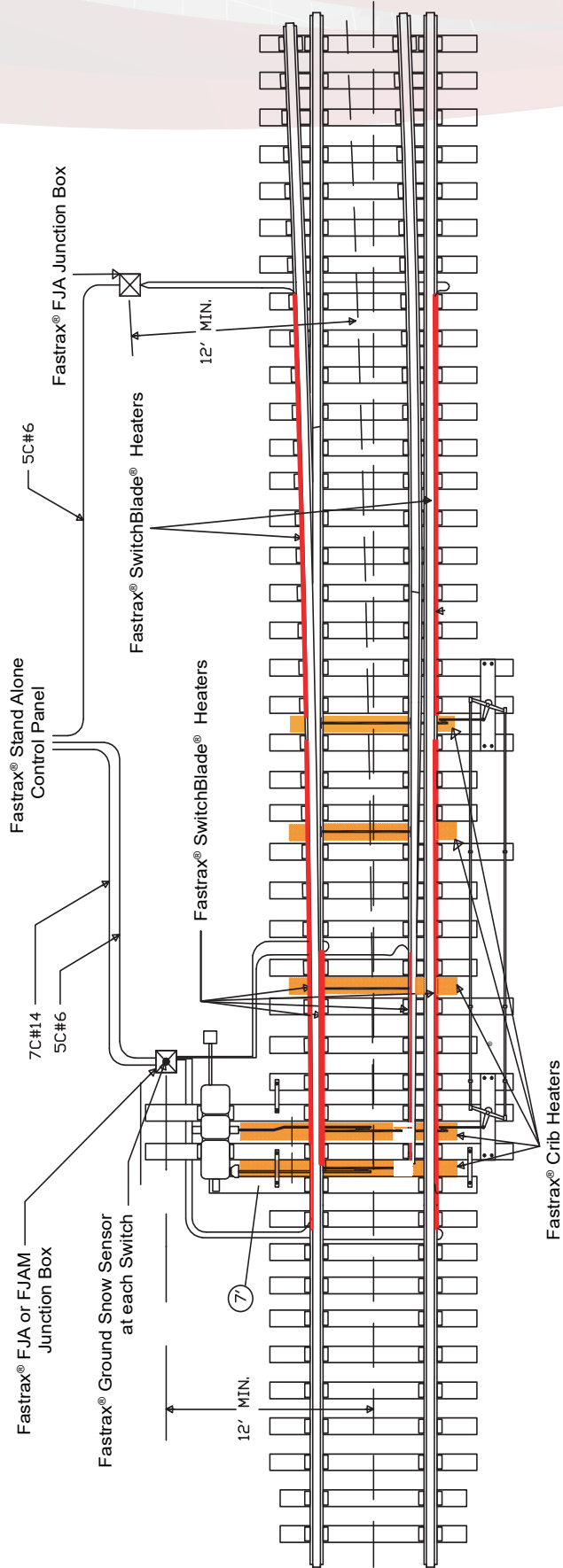
B.5 NO. 14, 15 OR 16 STANDARD SWITCH SIZE - ALL TIE STYLES

Typical layouts are not to scale and are to be used for general positioning of equipment only. Review your company standards for exact equipment layout.



B.6 NO. 20 / 24 STANDARD SWITCH SIZE - ALL TIE STYLES

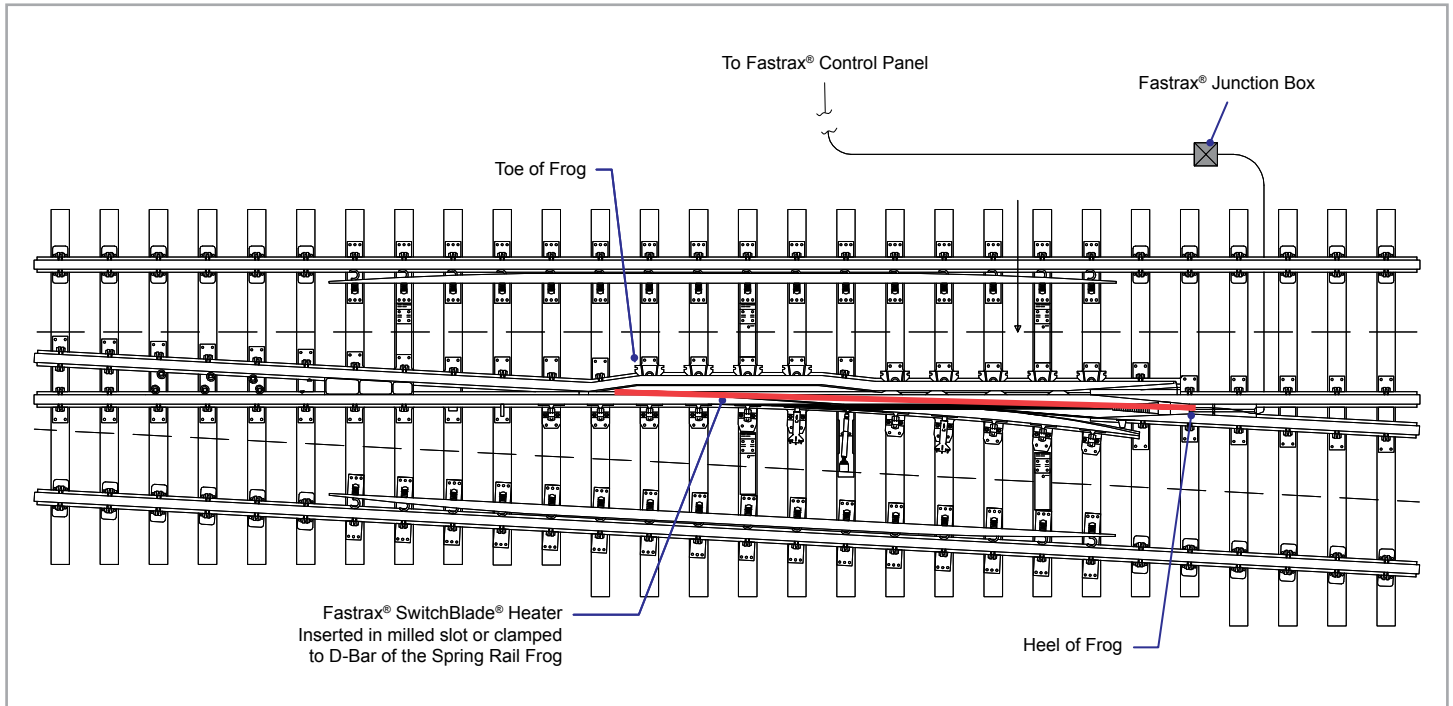
Typical layouts are not to scale and are to be used for general positioning of equipment only. Review your company standards for exact equipment layout.



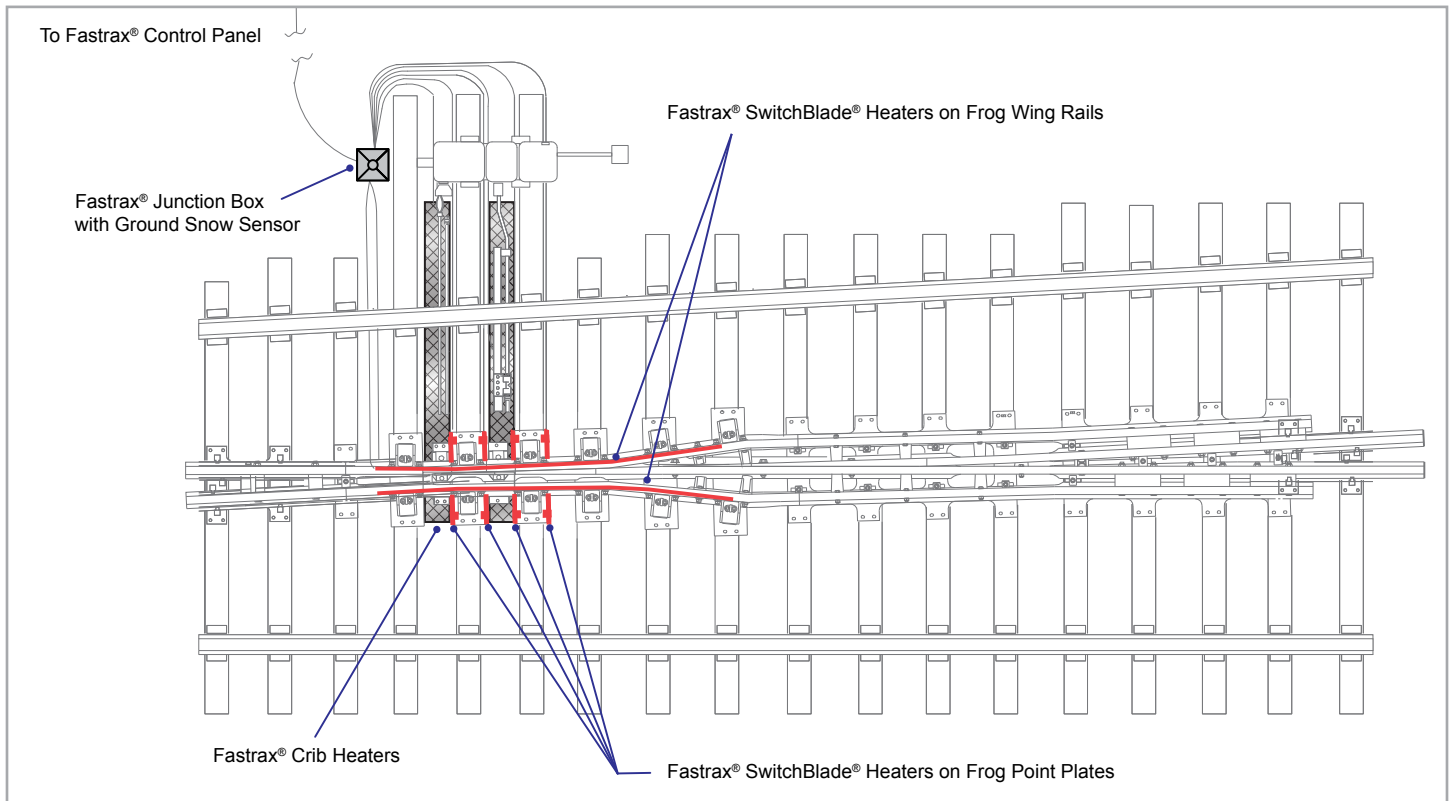
B.7 SPRING FROG AND MOVABLE POINT FROG HEATING LAYOUT

Typical layouts are not to scale and are to be used for general positioning of equipment only. Review your company standards for exact equipment layout.

Spring Rail Frog Heating Layout



Movable Point Frog Heating Layout



C. CONTROL PANEL INSTALLATION

C.1 ASSEMBLING FASTRAX® FCSA PANEL SUPPORT STRUCTURE

SUPPORT STRUCTURE COMPONENTS:

- 2 - 4" X 4" X 10' Bronze Powder-coated Support Posts
 - 1 - Upper Support Channel
 - 1 - Lower Support Channel
 - 2 - 4" Raceways
 - Channel Nut Bolt Assembly - (9) 3/8" Channel Nuts, (9) 3/8" X 1 1/2" Bolts, (9) Split Washers, (18) Stainless Steel Flat Washers
1. Place the support posts where the control panel will be installed with the unistrut channel facing up.



Figure C.1.1 - Unistrut channel position

2. Place the control panel on top of the unistrut channels at the 11" mark.



Figure C.1.2 - Control panel positioning

3. Slide one of the 3/8" channel nuts above and below the four control panel mounting holes. Use one 3/8" x 1 1/2" bolt and place one split washer and two stainless steel flat washers onto the bolt and fasten through each of the four control panel mounting holes and into the spring channel nuts and tighten.

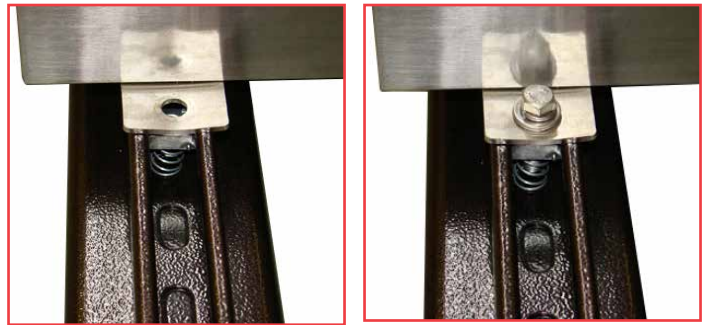


Figure C.1.3 - Nut and bolt positioning

4. Mount the upper support channel (this piece has a 1/2" conduit clamp attached to the back) at the 2" mark from the top of the post with the channel nut and bolt assembly.

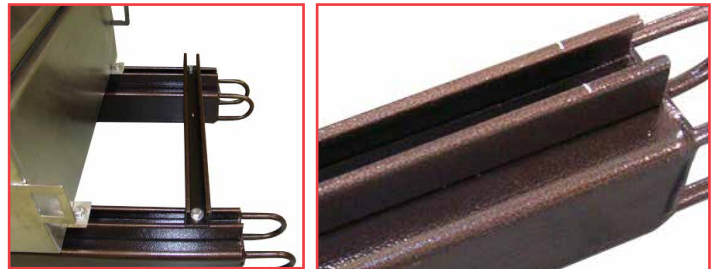


Figure C.1.4 - Upper support channel positioning

5. a) Measure 20" below the base of the control panel.
b) Mount the lower support channel with the channel nut and bolt assembly.



Figure C.1.5 - (a)



Figure C.1.6 - (b)

C.2 INSTALLING FASTRAX® FCSA PANEL

Note: For system operation and maintenance, see Reference Material pages 31 - 48.



1. Mark where the two, 10 ft support posts will be placed in the ground.
2. Install two, 12" sonotubes.
3. Set panel support posts in the sonotubes and adjust so that the channel support is 6 ft above ground level.

Note: For panels 4 ft or higher, place the top channel 7 ft above ground level.

4. Using temporary supports, level the panel support structure.
5. Pour concrete around the panel support posts, filling the sonotubes to ground level.
6. Allow concrete to cure completely.
7. Remove temporary supports.



C.3 INSTALLING WIRE CONDUIT RACEWAY TO PANEL

1.0 If Panel is Pre-punched for Conduit:

1. Trench below each punched hole to bury the conduit 2 ft below finished grade. Temporarily support the panel if necessary.

Note: Be careful not to weaken the panel support when trenching and installing conduit/underground cables.

2.0 If PVC Conduit is provided:

1. Two, 4" conduits are provided. One conduit is for the direct burial conductors coming from the switch and frog junction boxes. The other conduit is for the panel feeder wires coming from the service fused disconnect switch.
2. Install 4" PVC conduits for protecting direct burial wiring where the wire leaves the ground and enters the panel.

3.0 If PVC Conduit is Directly Connected From the Control Panel to the Junction Box or Service Equipment:

1. Only use materials approved by UL, CSA or FM third party test agencies. Install a minimum of 2" trade size conduit to each junction box or service equipment.
2. Locate and mark the holes needed for the conduit by holding a piece of the conduit vertically level with the panel support and against the bottom conduit support channel. Cut proper size conduit openings in the bottom of the control panel.
3. Only install the conduits at the bottom of the control panel. Use proper fittings with locknuts and plastic or metal bushings to protect conductors.



4. Clamp conduit to the lower support channel with the provided clamp.

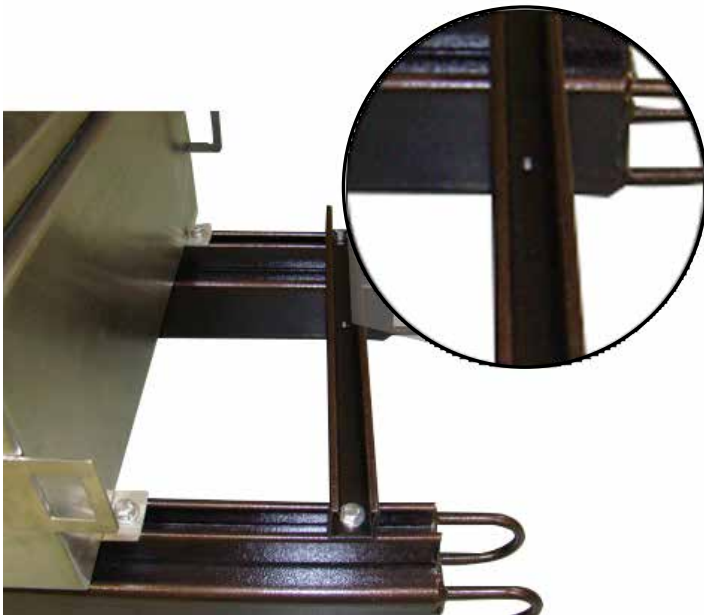
C.4 INSTALLING FASTRAX® AERIAL SNOW SENSOR & SUPPORT MAST

Note: If constructing your own support mast, please contact Fastrax®.

1. The aerial snow sensor support mast comes pre-assembled and packaged with the control panel support structure.



2. Loosely hold the mast in position with the one-hole strap pre-installed on the back of the panel support structure.



3. Locate, mark and cut the preferred location for the 1/2" fitting to enter the bottom of the control panel.
4. Using the 1/2" opening in the panel bottom, install the fitting, if provided.



5. Thread the wire attached to the FAS1A snow sensor through the 1/2" conduit support mast, through each elbow and into the panel.
6. Without twisting the snow sensor wire pull the wire snug so the 1/2" union provided with the snow sensor mates with the 1/2" conduit mast.
7. Tighten the 1/2" union with snow sensor in place.
8. Leave excess wire inside the panel until system is wired.

D. JUNCTION BOX INSTALLATION

D.1 JUNCTION BOX PLACEMENT

1. Loosely assemble each junction box to the support pedestal.
2. Place each junction box assembly near the area of installation. Refer to the System Layout section of this manual, to ensure each junction box is placed in the correct location.

Note: There are various types of junction boxes, refer to Figures D.1.1 - D.1.4, for product description.

Note: Always place the junction box in an area that provides good drainage. Excess water can enter the box causing ground fault tripping.



Figure D.1.1 - FJA200SUP Junction Box

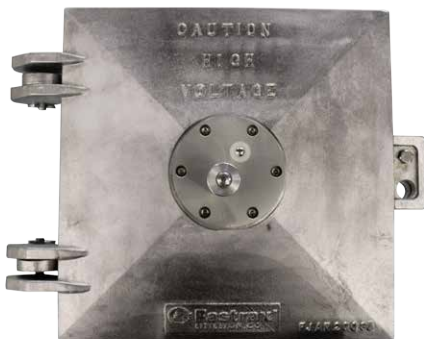


Figure D.1.2 - FJAM200SUP Junction Box with FGSP1A Ground Snow Sensor



Figure D.1.3 - Conduit Junction Box



Figure D.1.4 - Direct Burial Cable Junction Box

Note: Follow Railroad guidelines and specifications for trenching to prevent damage to existing buried lines. Always locate and mark existing cables before digging.

3. For the placement of the junction box support pedestal, dig a trench a minimum of 1 ft in diameter and 2 ft below grade.
4. Adjust the depth of the hole to position the junction box above the finished grade. We recommend that the bottom of the junction box extend a minimum of 2" above the finished grade.

D.2 DIRECT BURIAL CABLE AND CONDUIT TRENCHING

Note: Follow Railroad guidelines and specifications for trenching to prevent damage to existing buried lines. Always locate existing cables before digging.

1. For direct burial cable or conduit raceways, dig a trench a minimum of 2 ft below grade.



Figure D.1.5 - Trenching

2. Bury direct burial cables or conduit a minimum of 2 ft below grade unless otherwise outlined by Railroad or National Electrical Code standards.

D.3 DIRECT BURIAL CABLE , CONDUIT AND JUNCTION BOX INSTALLATION

1. Unscrew the four support flange bolts attached to the junction box from the support pedestal.

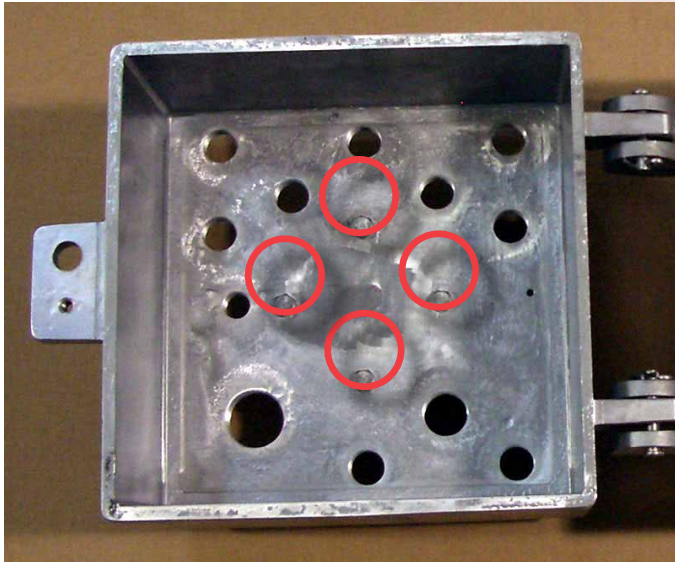


Figure D.1.6 - Support Flange Bolts

2. Install direct burial cable or conduit from the junction box to the control panel and position it for the finished location and height of the junction box.



Figure D.1.7 - Direct Burial Cable Junction Box

Note: For direct burial cables, use the glands provided in the accessory kit to properly terminate the cable for entry into the junction box.

Note: For customer provided conduit, prepare and terminate the conduit into the junction box with approved fittings such as terminal adaptors.

3. After the cables or conduits are in the junction box, replace the four support flange bolts and fasten the box in place.
4. Fill in trench, leaving an area around the junction box clear for easier heater lead installation.



Figure D.1.8 - Junction Box Installed

E. SWITCHBLADE® HEATER INSTALLATION

E.1 SWITCHBLADE® HEATERS (FIELD SIDE RUNNING RAIL) SWITCHES UP TO NO. 16

1. Locate the SwitchBlade® heater(s) for the running rail. Check that the proper voltage and length heater is placed near the installation location.
2. Uncoil the heaters, being careful not to bend or kink the heaters.
3. Place one heater on the field side of the rail and through the openings in the rail braces on one rail only.
 1. Position the heater end where the lead wire enters the round metal area approximately 2 ft in front of the switch point. (Up to 4 ft in front of the switch point is acceptable if necessary).
 2. Position the heater so a spring base style rail clamp can be installed about 10" from where the lead wire enters the heater, just beyond the heater offset.
 3. Position the heater so a clamp can be placed at the 'dead end' of the heater.

7. Important: The spring clamp body female thread is left handed. Turn swivel screw to the left or counter-clockwise to reinstall the spring body. When completely on, the spring clamp will travel freely on the swivel screw head so it can align with the heater position.
8. When tightening the spring clamp on to the heater apply gentle pressure on the spring clamp body toward the swivel head screw so the left handed threads do not catch or bind.

Note: The spring base rail clamp should be installed and removed by hand. Do not use a sledge hammer or other tools to install the clamp. The clamp body can be removed by backing the screw out all the way and pushing firmly on the top of the clamp body towards the rail.



Figure E.1.1 - Heater Installed with FRB600 spring rail clamp

Note: Allow proper clearance for heater to move freely.

4. Mark the rail where clamps are to be installed. Heaters should be clamped about every 2 ft. A common rule of thumb is to clamp each heater in every crib space. It is acceptable to space the clamps a bit further apart when necessary to avoid obstructions.
5. After marking the rail for clamps, mark the other running rail in the same locations.
6. Locate Model FRB600 spring rail clamps (Step 7.6 on opposite page) and install on the rail by hand.

9. Leave swivel screw and spring clip backed away from rail and slide heater in place.



1. Place clamp on field side of rail base with swivel screw backed completely out.



2. Push the bottom of the clamp body firmly until it clicks into place on the base of the rail. (Note: pushing on the top of the clamp will prevent it from seating on the rail).



3. The end of the clamp body will wrap around the gage side of the rail when seated properly.



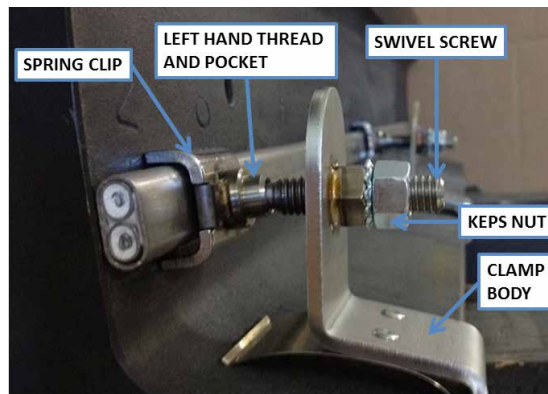
4. Tighten each clamp by turning the swivel screw with an Allen wrench until the spring clamp U shaped edges surround the heater and are snug against the rail.



5. Tighten the keps nut.



6. Tie off the tow hook at the heater 'dead end' with the stainless steel wire tie provided with the spring base clamp kits.



E.2 SWITCHBLADE® HEATERS (FIELD SIDE RUNNING RAIL) SWITCHES NO. 20 - 24

Size No. 20 and 24 switches have one extra heater on each running or stock rail as shown in the layout section (refer to page 12).

Please follow the previous rail heater instructions (page 19) for the front rail heaters on a No. 20 or 24 switch. Use the following instructions for the rear heaters:

1. When laying uncoiled heaters in place as in step 3 of the SwitchBlade® heater installation, lay the rear heater in place while feeding the 'dead end' in from the heel block location. Bring the 'dead end' to about 2" from the 'dead end' of the front heater.
2. If necessary, adjust both heaters to allow for proper clamp clearance and to have the 2" gap between heater 'dead ends' between rail braces.
3. Follow the marking, clamping and heater installation as on the front heater.
4. Install one stainless steel wire tie between the two 'dead ends' as shown below.



Install clamps on rear heater every 2".



Install the second heater from the rear of the switch so that the point of the rear heater meets the point of the front heater.



Tie the heater dead ends together with a stainless steel wire tie.

E.3 HEATER POWER WIRE TO JUNCTION BOX

1. Heater power wires are standard 26 ft from the factory. Uncoil the power wire on each heater and lay it in the general path it will be installed to the junction box. Place wires from each heater to the correct junction box as shown in the Layout Section of this manual.
7. Scratch a shallow channel in the ballast or dirt to bury the orange conduit with the heater wire inside. Route to the junction box .
8. Remove one plastic 3/4" NPT plug for each heater lead in the bottom of the junction box.



Figure E.3.1 - Lead Wire & Conduit



Figure E.3.3 - Remove 3/4" NPT plug

2. Using the FA0375 orange protective flexible conduit provided in the accessory kit, cut one section to cover each lead wire from the metal connection on the heater to the junction. Be sure to allow enough extra lead wire and orange conduit to loop below and into the bottom of the box.
3. From the accessory kit, locate one FHC125 stainless steel hose clamp for each piece of orange conduit.
4. Thread one FHC125 clamp over the heater wire and up to the round metal sheath where the wire enters the heater.
5. Thread the heater wire through the orange conduit with a fish tape if necessary.
6. The heaters generally will have a piece of cold shrink strain relief rubber over the area where the wire enters the heater. Slip the orange conduit as far as it will go over the rubber cold shrink and clamp in place with the FHC125 hose clamp.
9. Using one FA375PC black conduit connector for each wire, thread the connector into any 3/4" NPT opening provided in the bottom of the box. Loosen the outer nut on the connector and thread the wire through the connector into the box. Push the orange conduit into the connector and tighten the outer nut to hold the orange conduit tight.



Figure E.3.2 - Orange Conduit Clamping



Figure E.3.4 - Install Orange Conduit to Junction Box

10. Leave wires long inside the box until final connections are made.
11. Cover the orange conduit with the wire in it with ballast to prevent a tripping hazard.

Note: When heater shields are used, leave heater wire outside the end of the shield.

E.4 SWITCHBLADE® HEATER(S) FOR GAUGE SIDE OF THE MOVING RAIL

The following instructions are for new switch designs and made by only certain track system manufacturers. When applying SwitchBlade® heaters to your switch, please check to see if the clearance is on the gauge side of the switching rail you will need for installation as shown in these instructions.

Note: If your switch is of a different design or clearance is not there, please contact Fastrax® for instructions on how to install the SwitchBlade® heaters on the moving rail.

HEATER INSTALLATION COMPONENTS:

- (1) FSE32408 Fastrax® Switchblade® Heater (See Figure 1).
- (5) XTC0193 Fastrax® Spring Clamp (See Figure 1).
- (1) Stainless steel tie strap (See Figure 2).



Figure E.4.1 - SwitchBlade® Heater and Spring Clamps



Figure E.4.2 - Stainless Steel Tie Strap

1. Inspect track switch construction to confirm that the installed track switch appears as shown in Figure 3.

Note: Proper heater clearance must exist above the reinforcement bolts to allow for an unobstructed path for heater element to extend at least 8 ft from the switch point toward the switch heel.



Figure E.4.3 - Track Switch Construction

2. Marking clamp locations:

- a) Place heater next to the rail where it is to be installed.
- b) Mark clamp bolt locations.

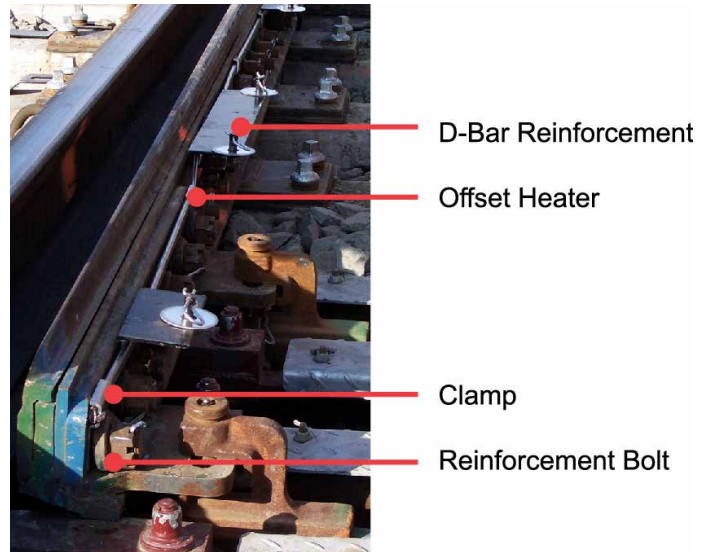


Figure E.4.4 - SwitchBlade® Heater Clamp Locations

Note: The switch clip adds approximately 1" thickness to the rail from the switch point to approximately 2 ft back (see Figure E.4.4). The heater will mount as shown over the switch clip and will gradually offset to follow the D-bar reinforcement as shown toward the switch heel.

Locating clamp bolts:

- c) Mark the first and last bolt for clamps on the switch clip.
- d) Mark the second bolt past the switch clip for clamp past the heater offset.
- e) Mark the third and fourth bolts approximately 24" apart from other clamps. Locate the last clamp approximately 10 to 14" from heater termination end.

3. Installing clamps:

- a) Install clamps one at a time.
- b) Remove cotter key and loosen the first hex nut leaving space to slide clamp body between the lock washer and the rail structure. (If a 1/8" flat washer exists under the lock washer, remove it and replace the lock washer and hex nut.)
- c) Tighten clamp and lock washer with hex nut to original tension and replace cotter key. Make sure the heater clamp is installed straight so the spring portion is directly in line with the heater direction.
- d) Repeat this step for installing the remaining four clamps.

4. Installing Heater:

- a) Slide heater in place under clamps as shown in Figure 3. Be sure the connection wire end is located toward the heel end of the switch. The eye hook end of heater should dead end at the switch point under the first clamp as shown in Figure 5.
- b) Bend the heater gradually to mount under clamps on the switch clip as shown in Figure 4.
- c) Using the stainless steel tie strap provided, insert the strap through the heater eye hook and the slot in the XTC0193 Clamp as shown in Figure 5.



Figure E.4.5 - SwitchBlade® Heater End Tie-off

5. Route the lead wire to the proper junction box as instructed under *E.3 - Heater Power Wire to Junction Box*. Moving rail heaters connect to the front (point) heater junction box.



Figure E.4.6 - Option used when clearance is limited

E.5 SWITCHBLADE® HEATER(S) FOR SPRING FROG (SPRING FROG CHANNEL STYLE)

Many new style spring frogs have a rectangular channel manufactured into the base of the frog casting. The channel is designed to extend from the frog heel to the toe and is open on each end.

Inspect your spring frog to see if it has a channel in the base. On the heel end of the frog the channel is not always enclosed under the first few ties until it rests on top of the gauge plate. Please remove enough ballast to feel under the frog body and see if a channel exists. If there is no channel see *E.6 SwitchBlade® Heater(s) for Spring Frog (Retrofit Style)*.



Figure E.5.1 - SwitchBlade® heater installation location

1. Locate and check the heater length to be sure it is the correct size for the frog. The heater will insert completely into the heel end of the frog channel up to the offset. The heater will come within 12" to 18" of the toe end of the channel but should not extend outside the channel toe end (refer to Figure E.5.2 and E.5.3).
2. Lay the heater close to its installed position and follow the 'Heater power wire to junction box instructions' in this manual to establish wire and orange conduit length. Pre-install the orange conduit on to the heater end with the FHC125 clamp before inserting in the frog channel.
3. Using a fish tape, make sure the channel is clear all the way through. Clear any dirt and debris blockage before installing the heater.
4. Push the heater into the channel being careful not to sharply bend or kink the heater. Guide heater into channel under first frog body until reaching the gauge plate.
5. Install the heater wire under the ballast.

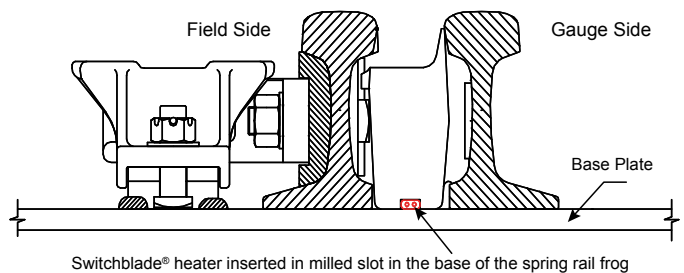


Figure E.5.2 - SwitchBlade® heater installation location

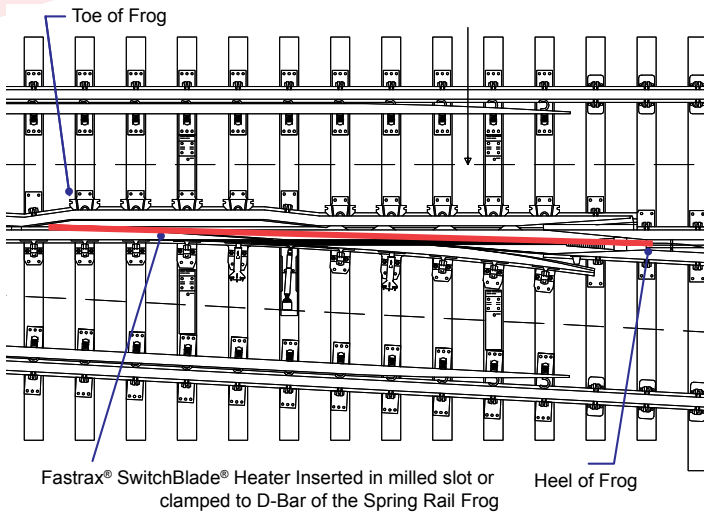


Figure E.5.3 - SwitchBlade® heater installation location

E.6 SWITCHBLADE® HEATER(S) FOR SPRING FROG (RETROFIT STYLE)

Older style spring frogs do not have a channel built in for a heater. Most however will have clearance under the horn bolt plates for the SwitchBlade® heater.

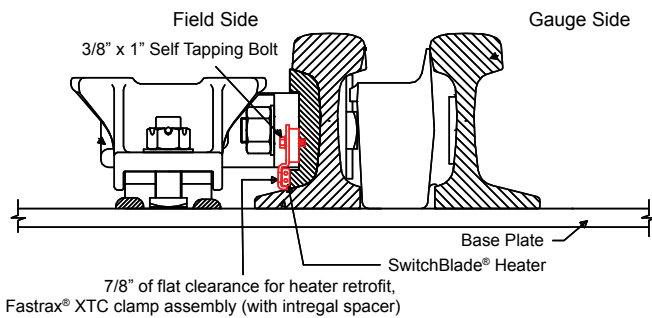


Figure E.6.1 - SwitchBlade® heater installation location

1. Locate and check the heater length to be sure it is the correct size for the frog. The proper size heater will have the offset lead wire end of the heater start between 2" to 10" before the D-bar reinforcement starts at the toe end of the frog. The heater then extends down the D-bar and ends about 12" to 18" before the D-bar ends.



Figure E.6.2 - SwitchBlade® heater end clamp

2. Lay the heater where it will be installed next to the D-bar. Using a clamp as a template, mark the bolt locations on the D-bar.
3. Mark the 1st clamp right where the D-bar reinforcement starts. Mark the rest of the clamps at 24" intervals and place one final clamp at the end of the heater.

Note: If proper clearance does not exist below the horn bolt spacers do not install heater and contact Fastrax® for instructions.

4. Remove heater from the frog.
5. Drill blind holes 5/8" deep into the D-bar reinforcement with 11/32" or letter S diameter drill.
6. Using the 3/8" X 1" self tapping bolts provided, install each XTC-0173SPACER clamp with the built-in spacer to the D-bar reinforcement. Be sure clamps are straight along with the heater direction so the heater does not bind when sliding in the clamps.
7. Slide heater into position under clamps. Heater must lie flat and straight on the D-bar reinforcement. Flat area of heater must make full contact with the D-bar surface. If heater does not lie flat, remove heater and manually straighten. The offset of the heater can face in toward the frog rail or casting to keep the lead wire out of harms way.
8. Tie off the tow hook on the end of the heater to the end clamp with the stainless steel wire tie provided.



Figure E.6.3 - SwitchBlade® heater clamp installed
*Look for proper clearance

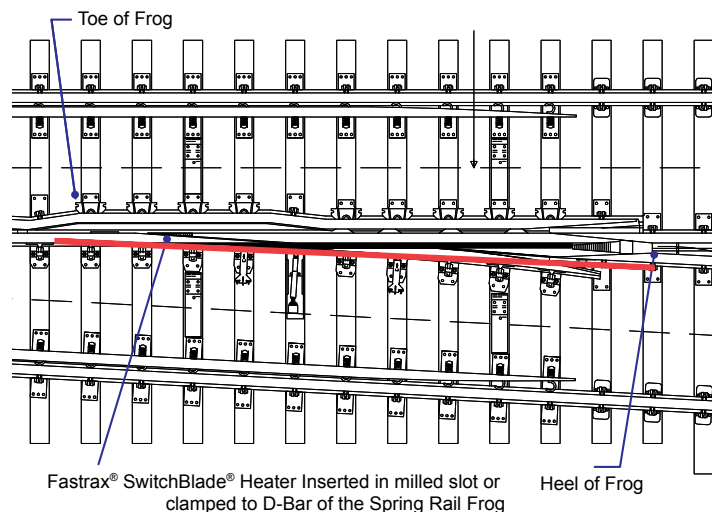


Figure E.6.4 - SwitchBlade® heater retrofit installation location

E.7 MOVABLE POINT FROG - SWITCHES NO. 20 - 24

Many new style movable point frogs (MPF) have the following design features to allow easy access for the SwitchBlade® heaters. Please inspect the MPF for the following:

- a) Slots in the wing rail braces to allow the SwitchBlade® heater to slide on to the top of the base of each wing rail. (Refer to Figure E.7.1).



Figure E.7.1 - SwitchBlade® heater installed on frog wing rails

- b) 4 channels welded on to the bottom of the base plate just below the point area. (Refer to Figure E.7.2).



Figure E.7.2 - SwitchBlade® heater installed on frog point plates

Note: If the features noted in a) and b) are not present please contact Fastrax® for alternate instruction methods. Please note that all frogs and heaters are not compatible.

1. Locate the heating equipment for MPF including two wing rail SwitchBlade® heaters, approximately 12 ft long, 4 plate SwitchBlade® heaters, approximately 3 ft long and 2 crib heaters, 8 ft 8" long. Lay out equipment near MPF.
2. Install crib heaters (refer to Section F - Crib Heater Installation).
3. Beginning at the point end of the MPF, slide each wing rail SwitchBlade® heater along the base of each wing rail through the slots provided in the braces. Any non-toxic lubricant may be used and it will evaporate once the heaters are turned on. Allow the heater to follow the contour of the rail as it is inserted toward the heel of the MPF.

4. Slide each plate SwitchBlade® heater into the channel provided under the base plate beneath the point area. Two of these channels will generally be located in each hollow steel tie or between concrete ties where the switch rods are located.
5. Support lead wires inside orange conduits above the crib heater platforms, if possible so they are protected from the platform heat.
6. Install the heater lead wires under the ballast to the junction box as previously described in this manual.

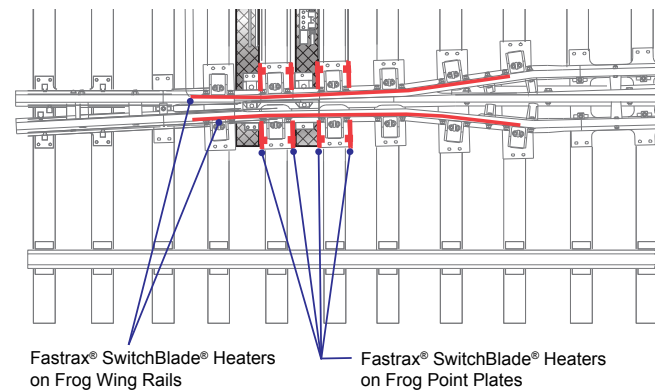
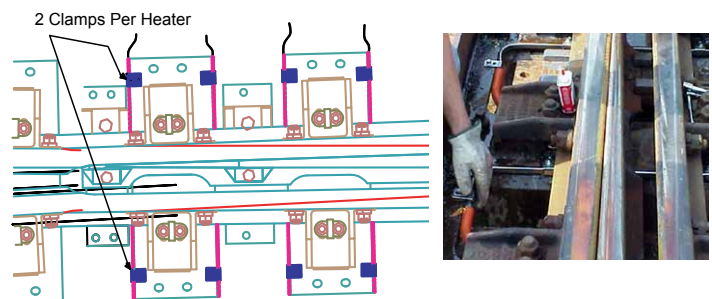


Figure E.7.3 - Refer to Section B - System Layout for an exploded view of the layout.



NOTE: To apply retrofit heaters to obsolete plate style movable point frog, contact Fastrax®.

Figure E.7.4 - To apply retrofit heaters to obsolete plate style movable point frog, contact Fastrax®.

Note: Frog heaters have a ground wire and may shunt track circuits in some cases. If signal problems are present after installing heaters, disconnect the heater ground wire.

F. CRIB HEATER INSTALLATION

F.1 ALL SWITCH AND FROG SYSTEMS

Fastrax® crib heaters have a unique low profile design to fit all switch and frog designs including conventional wood, composite, rubber, concrete or hollow steel ties.

We recommend using the 8 ft 8" units for all applications unless access space for installation prohibits using this length. If other lengths are required contact CCI Thermal Fastrax®.



Figure F.1.1 - Jack Bolt Mount



Figure F.1.2 - Hollow Steel Tie Mount

1. Review *Section B - Heater Layout* for the crib heater placement. In extremely severe weather areas crib heaters may be applied under any moving rod on the switch or frog.

2. Locate the crib heaters for your project and place them near the area they will be installed. Check the heater nameplate for proper voltage.
3. Between conventional ties, remove the ballast to allow 2" of clearance below the switch rods.
4. For heating cribs with switch rods connecting to a switch machine, place the heater under the rod all the way up to the switch machine. For other cribs, center the heater under the gauge of the rail.
5. For conventional ties, use the jack-bolt clamps provided. Turn the bolts counter-clockwise to allow the bolts to sit into each tie until secure.
6. Replace the ballast around the heater up to the top of the heater platform.
7. For hollow steel ties, remove the four gold plated jack bolts. It may be necessary to also remove the four 3/4" x 1" bolts at the same time. After sliding the crib heater on the bottom of the hollow steel tie, tighten the 4 smaller bolts into the side of the hollow steel tie until snug.
8. Route the heater lead wires as covered in this manual to the point area junction box.

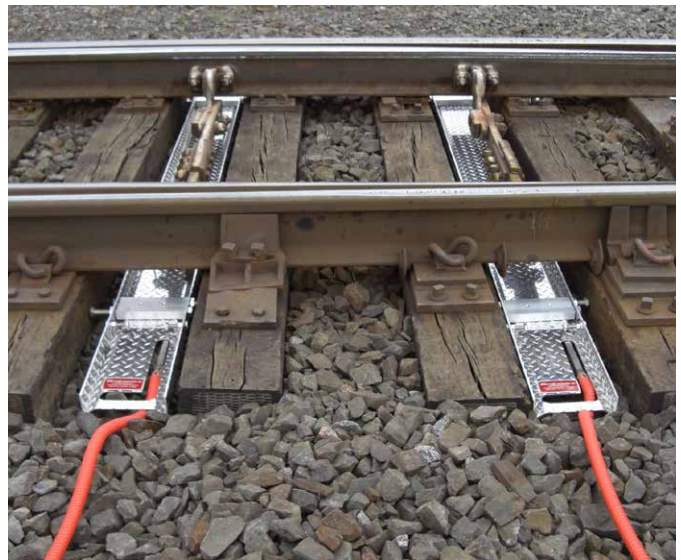


Figure F.1.3 - Crib Heater Installation

G. SYSTEM WIRING

Section B - System Layout shows generally used minimum wire sizes and number of conductors to be installed between panels and connection points for 240V and 480V systems.

Note: Always size conductors and electrical equipment to carry actual load conditions. Use Railroad and National Electrical Code standards for guidelines. **Use only copper conductors.**

Note: Pay close attention to the routing and number of cables required between connection points. Multiple conductors are required between master and Extension panels for control operations. Multiple conductors are also required between the control house and each master or stand alone panel to provide for dispatch control and annunciation.

IMPORTANT NOTE

Surge Protection Recommendations

This switch heater utilizes a number of processor-based control systems, all of which are susceptible to damage from lightning and other electrical surges. While every effort has been made to ensure that the control systems have been adequately 'hardened', CCI Thermal's surge mitigation efforts can only be effective if ALL external remote circuits connecting to the switch heater have been protected by primary surge protection devices in accordance with the following generally accepted requirements for surge protection of wayside signal equipment:

- Provide primary surge protection devices (standard signal air gap arresters) on all external switch heater control I/O circuits. These arresters should be located "upstream" of the switch heater housing (within the signal housing, which interfaces to the switch heater). It is essential to protect ALL circuits entering or leaving the signal housing.
- Provide a primary surge protection device (commercial high capacity MOV type) on the external switch heater ac power feed. This surge protection device should be located "upstream" of the switch heater in conjunction with the electrical service entrance panel and main disconnect. Observe primary surge protector manufacturer's instructions for installation and circuit breaker protection (if required).
- Grounding of the switch heater metal housing as well as the ground terminals of the primary arresters is essential for personnel protection as well as surge protection. Grounding rods and conductors must be installed in accordance with the AREMA Signal Manual of Recommended Practice.
- Primary surge protection must be installed in accordance with the AREMA Signal Manual of Recommended Practice.

For system designs not covered in this manual or questions please contact Fastrax® or consult your Railroad specification guide for more information on our systems.

1. Ensure all direct burial cable or conduit with wire is in place.
2. Terminate the wires at the control panel and at the junction boxes. If the wiring is not installed in the raceways, please do so now and size the conductors as shown in *Section B - System Layout* or consult the National Electrical Code for sizing guidelines. **Use only copper conductors.**

Note: Neatness and attention to detail count when wiring the system. Please pay close attention to number markings on the wires and keep the wiring area neat and clean.

G.1 CONTROL PANEL WIRING

For your convenience, all field wiring connection terminals are located in the bottom section of the control panel only. Wiring and conduits enter the control cabinet through the bottom to protect the panel from water entering.

G.2 CONTROL PANEL DISCONNECT FEEDER WIRING - STAND ALONE AND SLAVE PANELS

1. Find the amperage rating on the nameplate of each panel. Install feeder service sized to supply the panel amperage rating.

Note: Most panels rated at 100 amperes may be supplied with No. 2 copper wire. Most panels rated at 200 amperes may be supplied with No. 2/0 or 3/0 copper wire.

Note: Consult the National Electrical Code or your engineering department for final wire sizing and type of wire insulation required.

2. Determine how many conductors are needed to supply your panel. We recommend installing 3 full size conductors with an additional green or bare grounding wire for any single-phase panel and 4 full size conductors with an additional green or bare grounding wire for any three-phase panel. The grounding conductor can be full size or reduced size as shown in Article 250 of the National Electrical Code.
3. Install the feeder conductors from the service disconnect to the panel leaving enough slack in the wire to connect to the disconnect lugs.

4. Identify each feeder conductor with a phase color tape on each end. Black, red, and blue are commonly used to identify the individual phases. White or grey identifies the neutral conductor, but we do not require a neutral conductor for power to our panels. If a neutral conductor is installed please tape it off and leave disconnected at the Fastrax® heater control panel. Green color or bare wire always identifies the equipment grounding conductor.
5. Strip the ends of each feeder conductor.
6. Install one conductor under each disconnect lug.
7. Connect the green or bare grounding conductor to the lug on the back panel marked with the grounding symbol.
8. Using the proper Allen wrench, socket or screw driver, tighten to the proper torque as shown below. Leave power off until start-up.

Table G.2-1 Torque Values

Description	Torque (in/lb)
175 - 200 Amp Disconnect	200
80 - 100 Amp Disconnect	50
400 Amp Disconnect	375

G.3 CONTROL PANEL SWITCHBLADE® HEATER WIRING - STAND ALONE & EXTENSION PANELS ONLY

1. Locate the wiring diagram on the following pages for your control panel style. A basic wiring diagram is also permanently affixed to the inside of the dead front panel for reference.
2. As shown in the Layout Section, stand alone panels need (12) No. 14 American Wire Gauge (AWG) conductors from the stand alone panel to the signal control house. Identify and mark the panel end and the signal control house end of each conductor.
3. As shown in *the Layout Section*, Extension panels need (12) No. 14 AWG conductors from the extension panel to the master panel. Identify and mark the extension panel end and the master panel end of each conductor.
4. Using the wiring diagram for guidance, bend wires close to their connection point. Strip the wire insulation and connect each wire as shown tight to the torque value shown in Table G.3-1. Terminals marked SP are for spare conductors.



Before testing tightness of any electrical connection disconnect electrical feeder to control panel to ensure entire panel is de-energized.

Table G.3-1 Electrical Equipment Clamp/Screw Torque Values

Part Type	Description	Torque (in/lb)
Terminals	Control Circuits	9
Terminals	Crib Heater Circuits	10
Terminals	Heater Load Circuits	16
Terminals	Ground Block Terminals	12
Disconnect	Up To 100 Amperes	50
Disconnect	100 To 200 Amperes	200
Disconnect	400 Amperes	375
Contactors	Pressure Plate Lugs	15 - 20
Contactors	Box Lugs	40 - 45
Pwr. Dist. Block	Primary	120
Pwr. Dist. Block	Secondary	45
Circuit Breakers	Heater And Control Loads	17.7

G.4 MASTER CONTROL WIRING

1. Locate the wiring diagram on the following pages for your master control panel style. A basic wiring diagram is also permanently affixed to the inside of the dead front panel for reference.
2. As shown in the Layout Section, master panels need (12) No. 14 AWG conductors connecting to each extension panel and (12) No. 14 AWG conductors connecting to the signal control house. Identify and mark the master panel end, the extension panel end, and the signal control house end of each conductor.
3. Using the wiring diagram, bend wires close to their connection point. Strip the wire insulation and connect each wire as shown tight to the torque value shown in Table G.3-1. Terminals marked SP are for spare conductors.
4. Connect the extension panel conductors.



Before testing tightness of any electrical connection disconnect electrical feeder to control panel to ensure entire panel is de-energized.

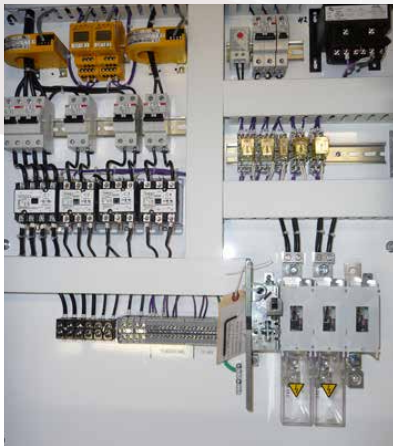


Figure G.4.1 - Typical Extension Control Panel

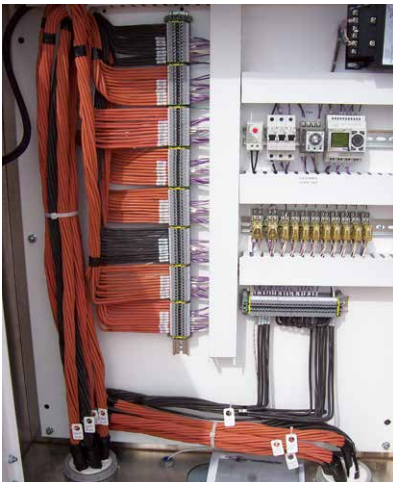


Figure G.4.2 - Typical Master Control Panel

G.5 FAS1A AERIAL SNOW SENSOR WIRING

1. Mount and install FAS1A sensor and wire as instructed in the Control Panel section of this manual.
2. Locate the wiring diagram for your panel style in this section. FAS1A sensors are only connected to master or stand alone panels.
3. Leaving extra slack in the panel cut the sensor wire to comfortably reach their designated terminals. Strip the insulation from each conductor leaving about 5/8" bare wire. Connect the wire colors as per Table G.5-1.

Table G.5-1 Wire Descriptions

Wire Color	Description	Terminal Number
Black	Common	60
White	Signal	61
Red	Supply	62
Green	Supply	62



Figure G.5.1 - FAS1A Aerial Snow Sensor

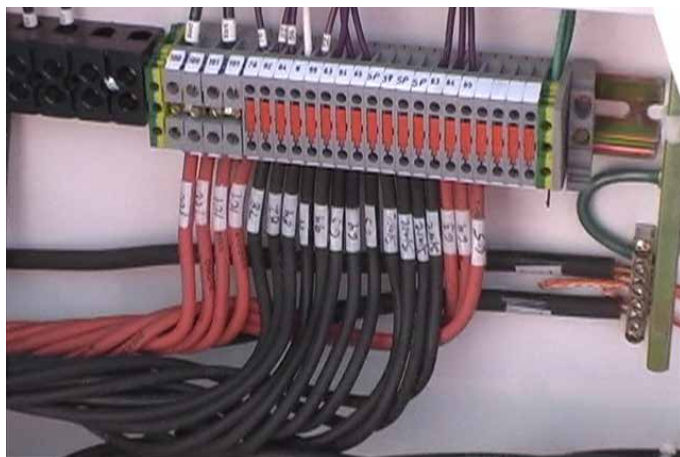


Figure G.5.2 - Terminal Connections

G.6 FGSP1A GROUND LEVEL SENSOR WIRING AT PANEL

1. Mount and install FGSP1A ground snow sensor style junction box (FJAM200SUP) and field wires to junction box as described in this manual.
2. Locate and identify each end of three of the seven 14 AWG wires installed from the panel to the junction box. It is helpful to identify with the numbers 63, 64 and 65 where possible.
3. Locate the wiring diagram for your panel type in Section H - System Wiring Diagrams. FGSP1A ground snow sensors are connected to extension or stand alone panels.
4. Leaving extra slack in the panel, cut the sensor wire to comfortably reach their designated terminals. Strip the insulation from each conductor leaving about 5/8" bare wire. Connect the wire colors as per Table G.6-1.

Table G.6-1 Wire Descriptions

Wire Color	Description	Terminal Number
Black	Common	63
White*	Signal	64
Red	Supply	65
White*	Supply	65

*White wires are interchangeable.



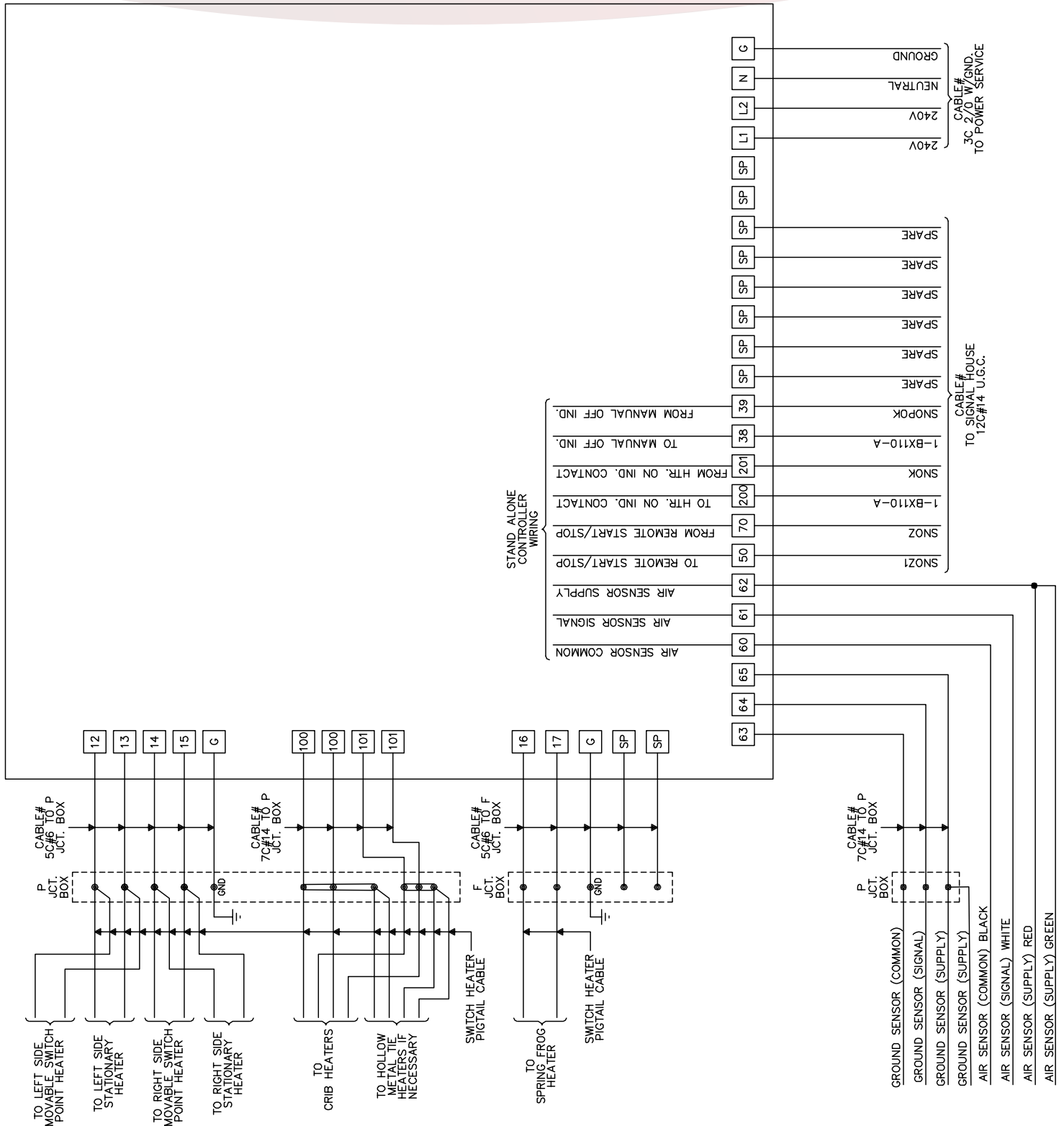
Figure G.6.1 - Snow Sensor Wiring

5. Once all conductors are terminated correctly at the panel and the system is checked for proper operation, seal the wires in the conduit entries to prohibit water from entering the panel. Use electrically approved sealing cement, duct seal or other approved material.

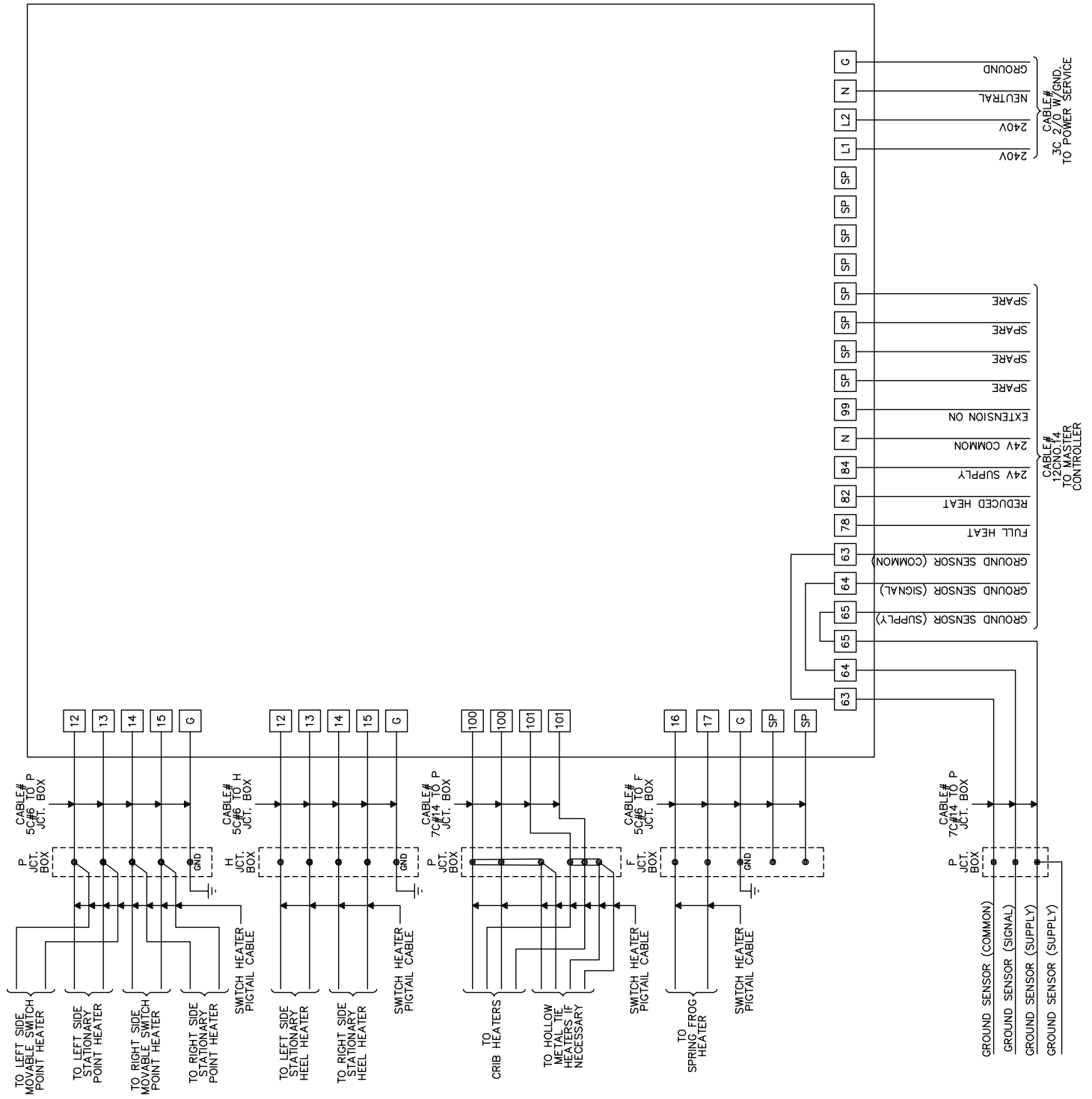


Figure G.6.2 - Sealed Conduits

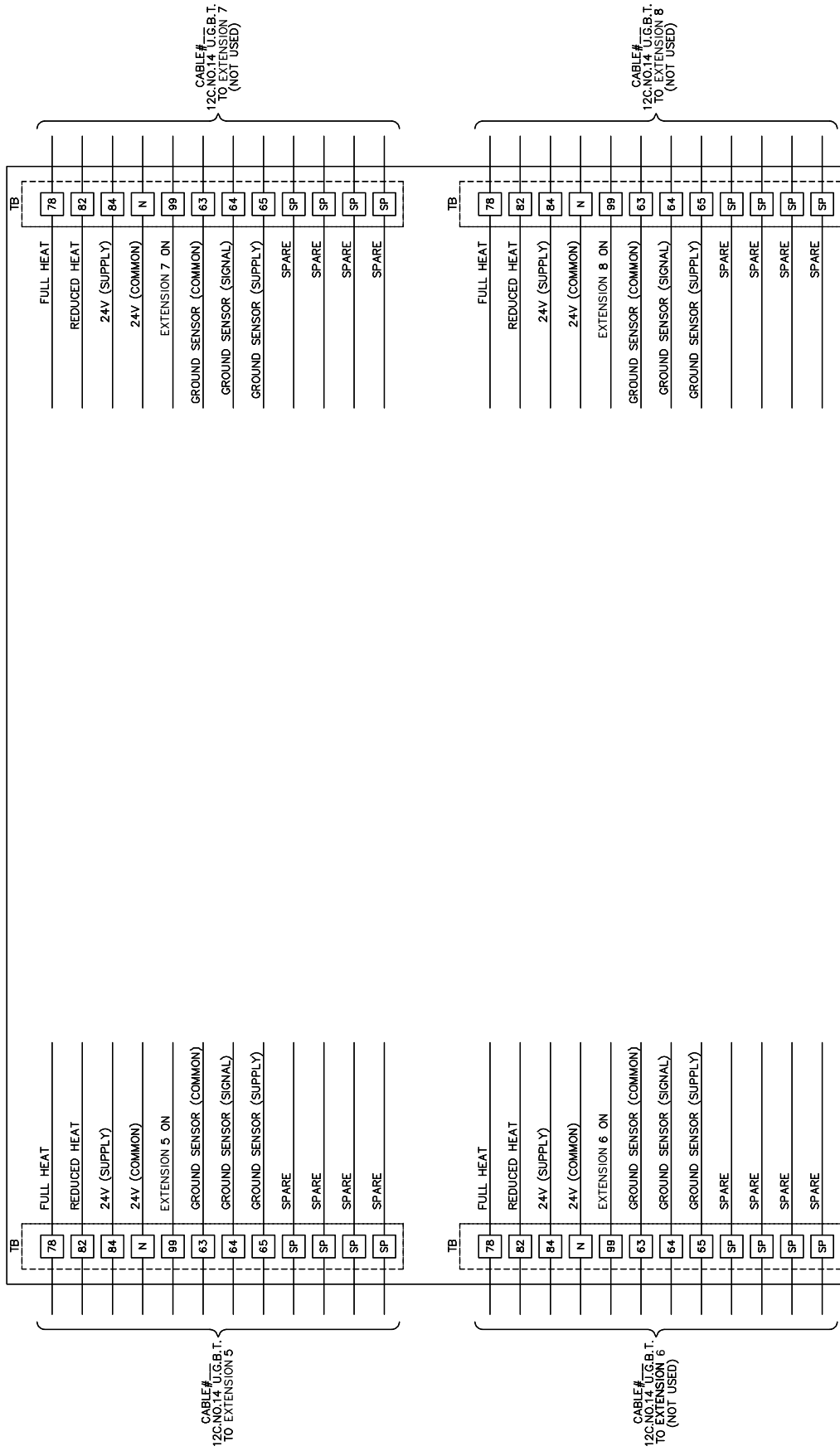
H.3 STAND ALONE CONTROL PANEL WIRING DIAGRAM (1) NO. 14, 15, OR 16 SWITCH & SPRING FROG HEATING SYSTEM



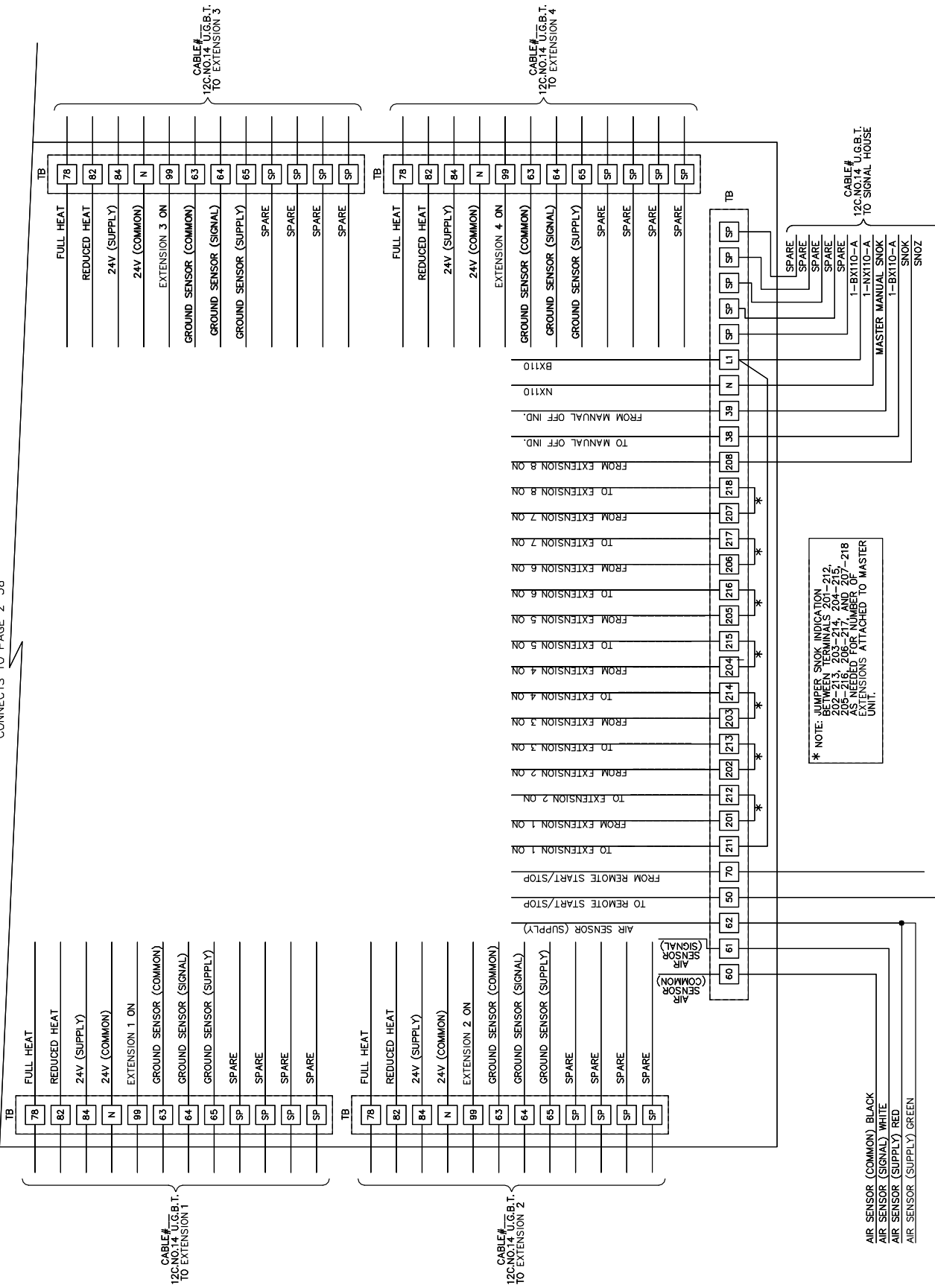
H.7 EXTENSION CONTROL PANEL WIRING DIAGRAM (1) NO. 20 OR 24 SWITCH & MOVABLE POINT FROG HEATING SYSTEM



H.8 MASTER CONTROL PANEL WIRING DIAGRAM UP TO (8) FASTRAX® EXTENSION PANELS



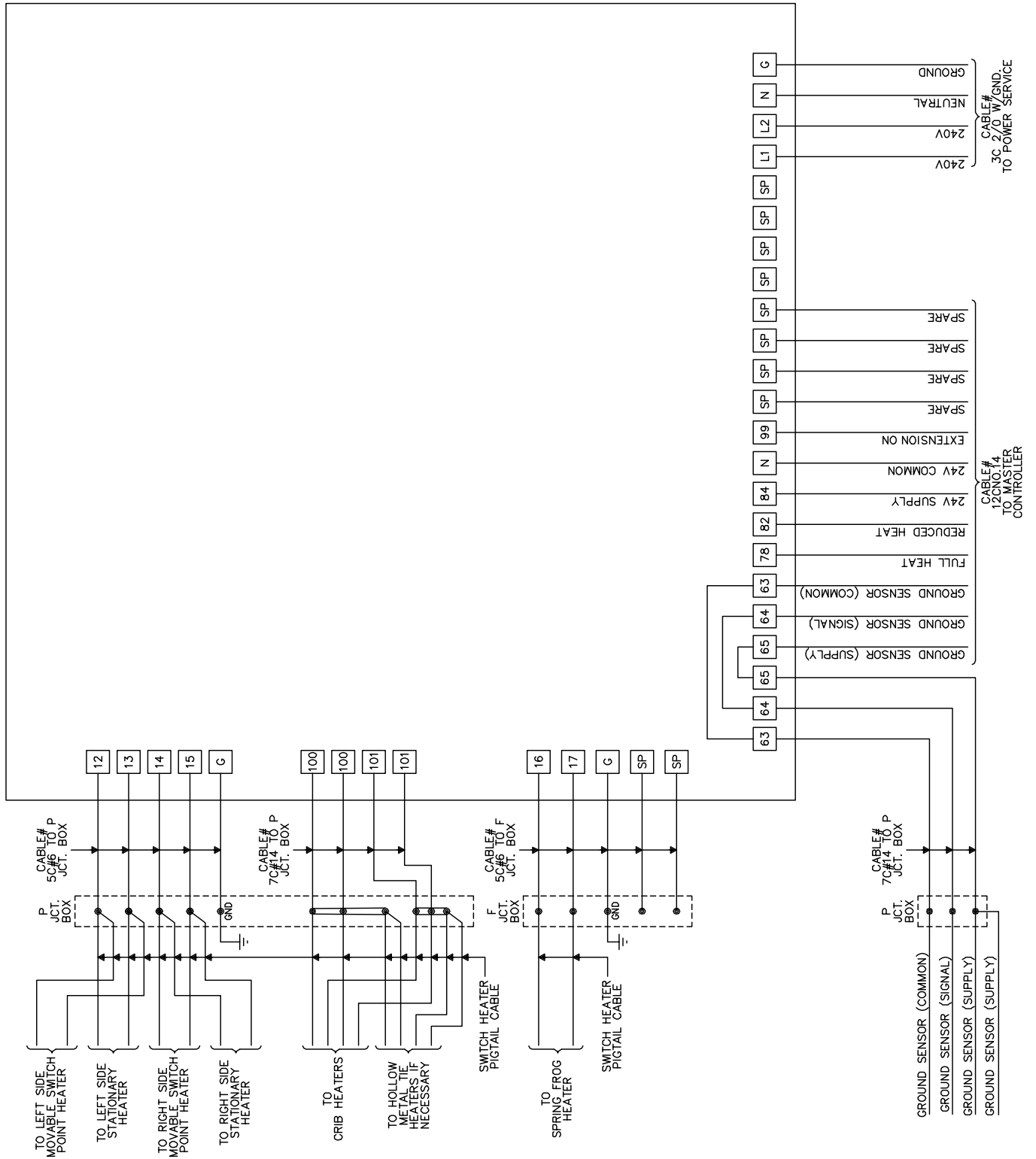
CONNECTS TO PAGE 1 - 39



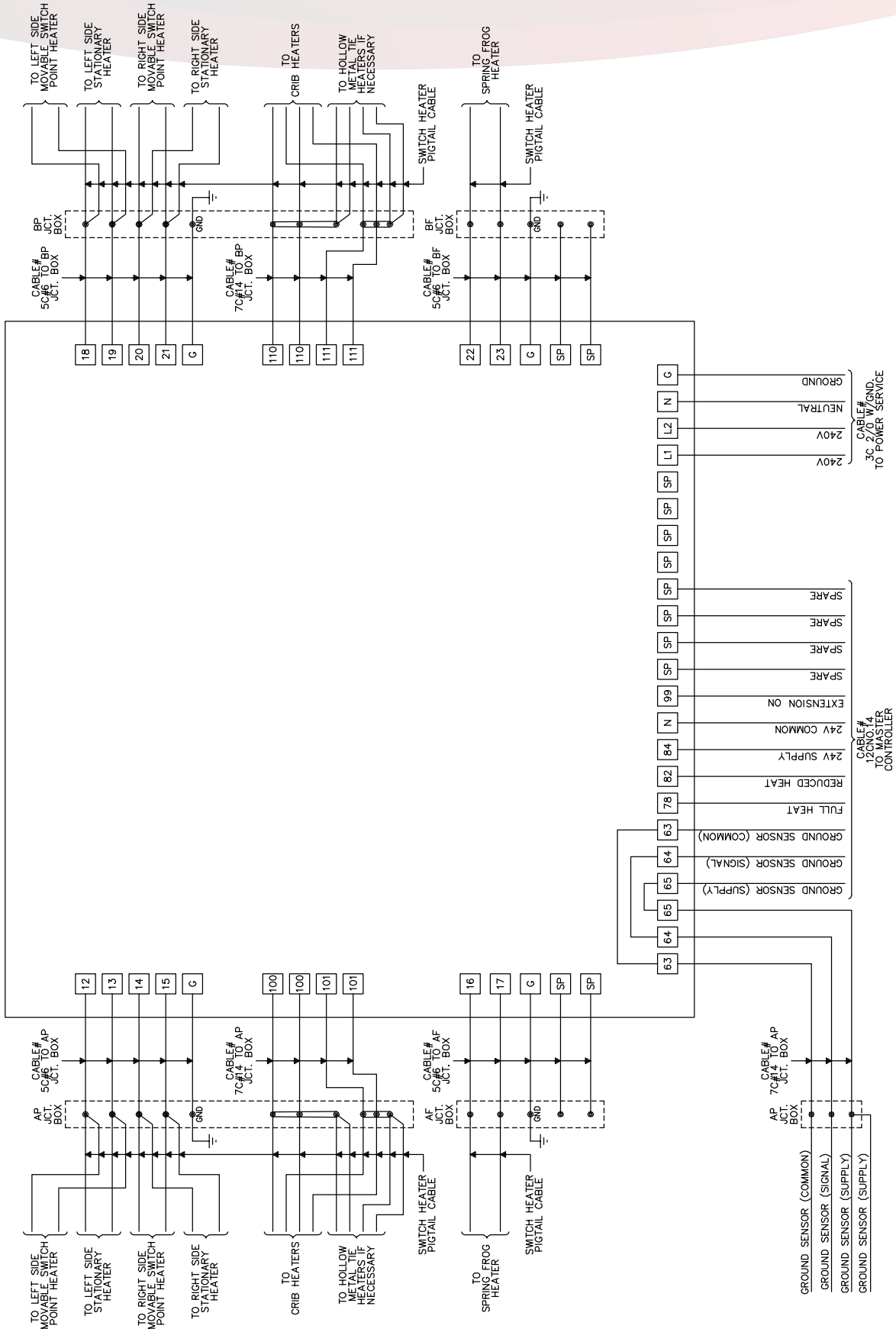
* NOTE: JUMPER SNOK INDICATION BETWEEN TERMINALS 201-212, 202-213, 203-214, 204-215, 205-216, 207-218 AND 219-220 AS NEEDED FOR NUMBER OF EXTENSIONS ATTACHED TO MASTER UNIT.

AIR SENSOR (COMMON) BLACK
 AIR SENSOR (SIGNAL) WHITE
 AIR SENSOR (SUPPLY) RED
 AIR SENSOR (SUPPLY) GREEN

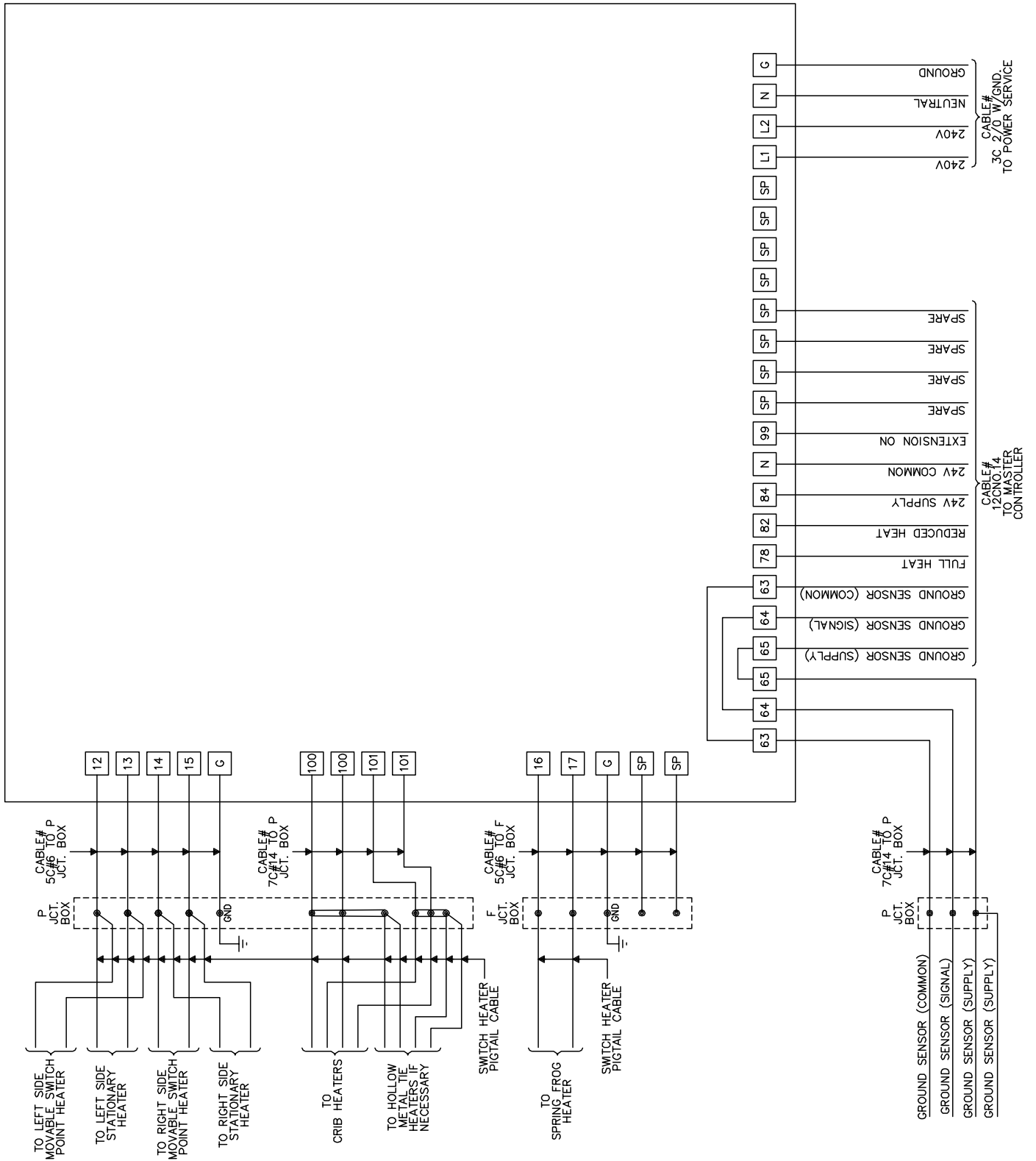
H.9 EXTENSION CONTROL PANEL WIRING DIAGRAM (1) NO. 9, 10, OR 11 SWITCH & SPRING FROG HEATING SYSTEM



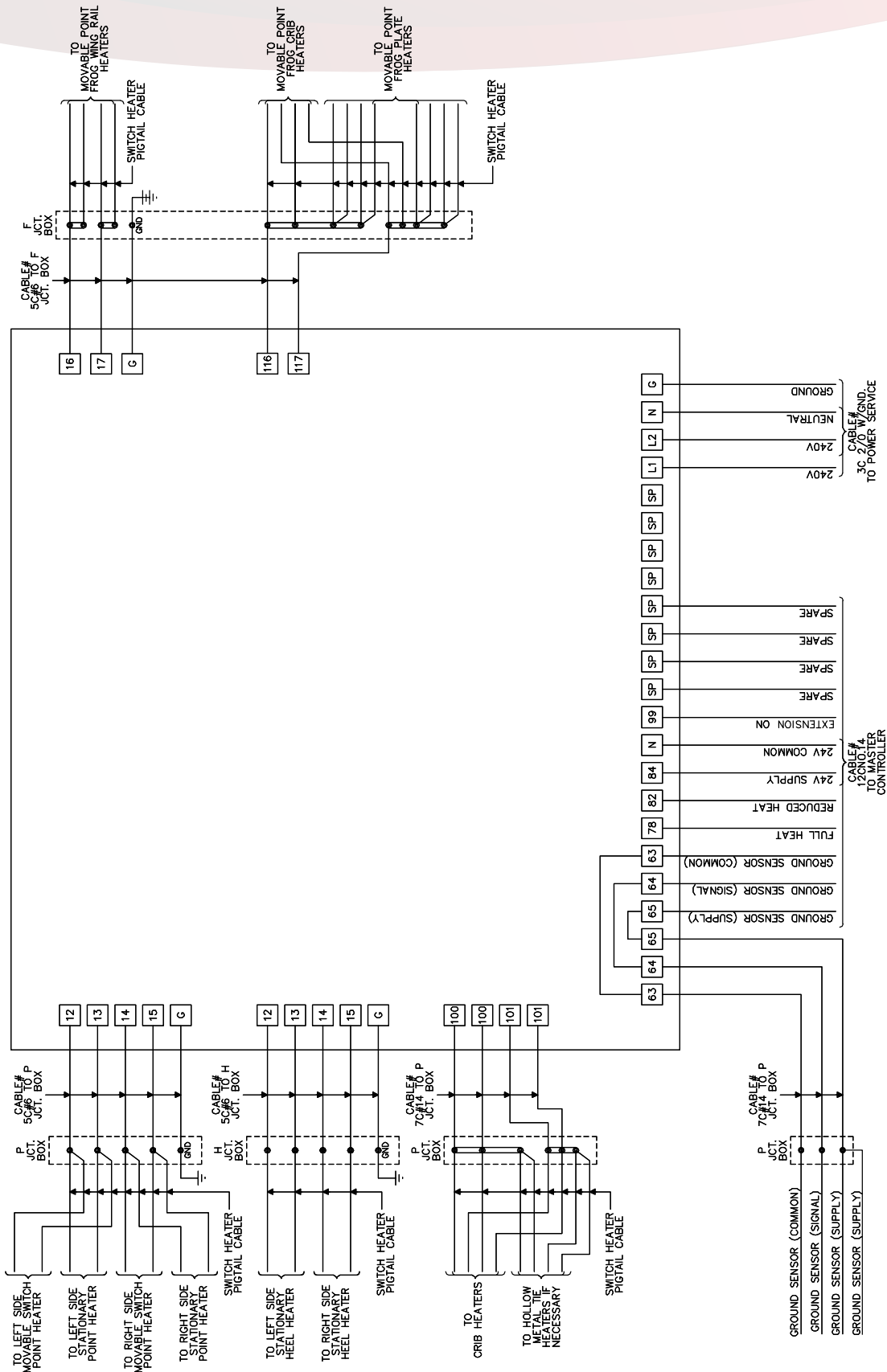
H.10 EXTENSION CONTROL PANEL WIRING DIAGRAM (2) NO. 9, 10, OR 11 SWITCH & SPRING FROG HEATING SYSTEM



H.11 EXTENSION CONTROL PANEL WIRING DIAGRAM (1) NO. 14, 15, OR 16 SWITCH & SPRING FROG HEATING SYSTEM



H.12 EXTENSION CONTROL PANEL WIRING DIAGRAM (1) NO. 20 OR 24 SWITCH & MOVABLE POINT FROG HEATING SYSTEM



H.13 JUNCTION BOX CONNECTIONS

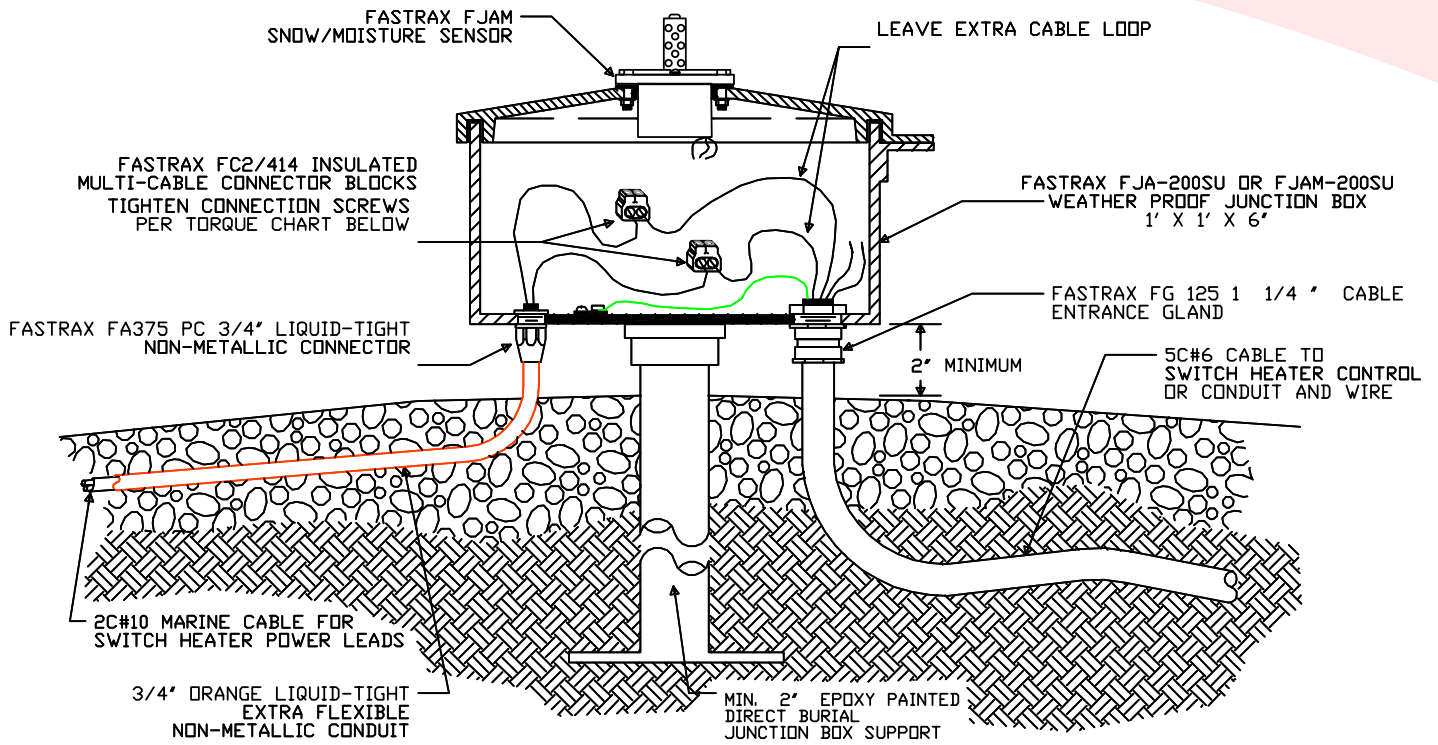


Figure H.13.1 - Side View of a Typical Junction Box Installation

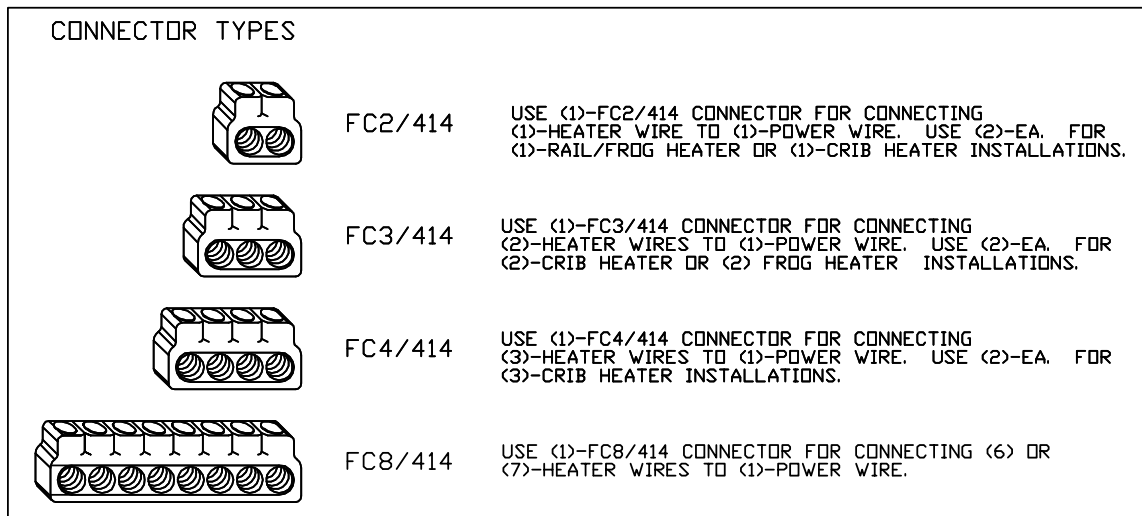


Figure H.13.2 - Fastrax® FC Insulated Connectors Used For Wire Connection In Junction Box

Table H.13-1 - Insulated Connector Torque & Strip Chart

Wire Size (AWG)	Torque (in/lb)	Strip Length (in)
#14 - #10	35	11/16
#8	40	11/16
#4 - #6	45	11/16

H.14 JUNCTION BOX HEATER CONNECTIONS

Wire entrances are located as shown in Figure H.14.1.

Note: When using conduit, cable connectors or glands, please be sure there are no burrs or sharp edges that will damage wire insulation inside the junction box.

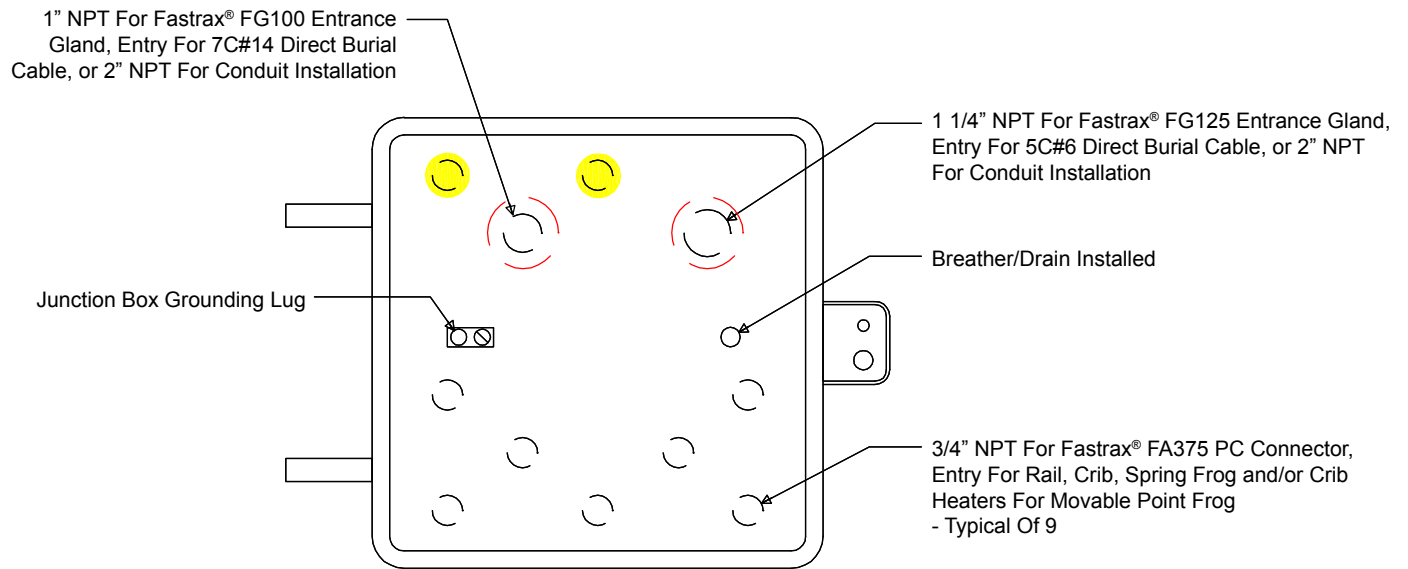


Figure H.14.1 - Top View of Junction Box, Cover Removed

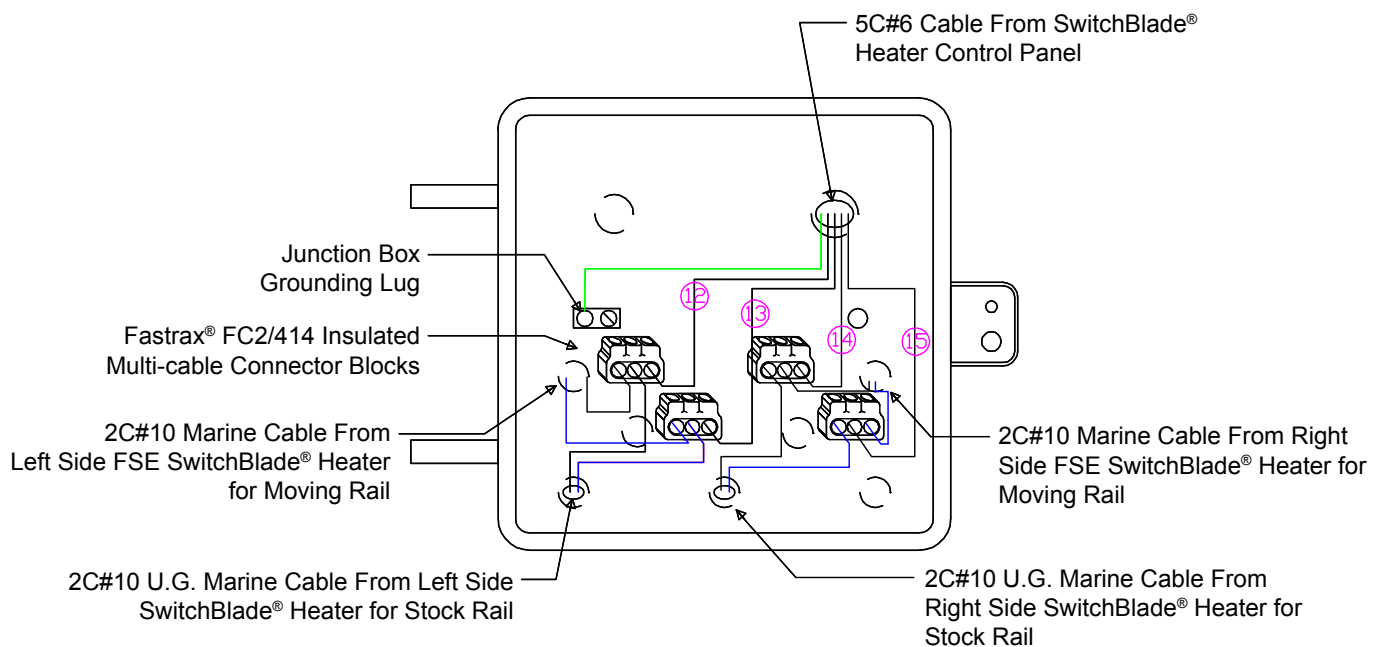


Figure H.14.2 - Typical Junction Box Connections - Showing SwitchBlade Heaters (2) for Moving Rails and (2) for Stock Rails

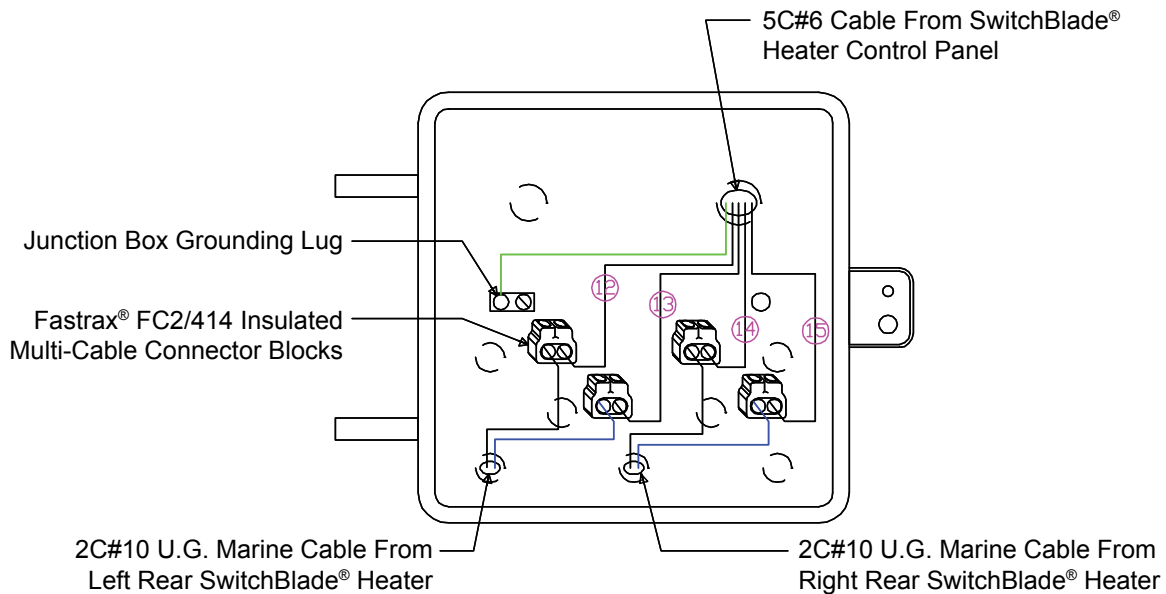


Figure H.14.3 - No. 20 or 24 SwitchBlade® Heater Running Rail Connections - Left and Right SwitchBlade® Heaters At Rear Junction Box

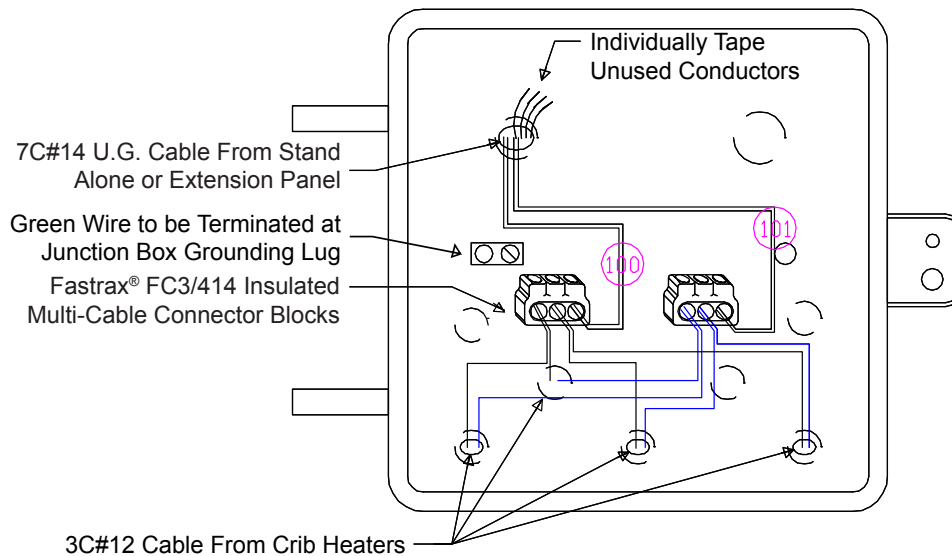


Figure H.14.3 - Crib Heater Typical Connections - (4) Crib Heaters at Switch Point Junction Box

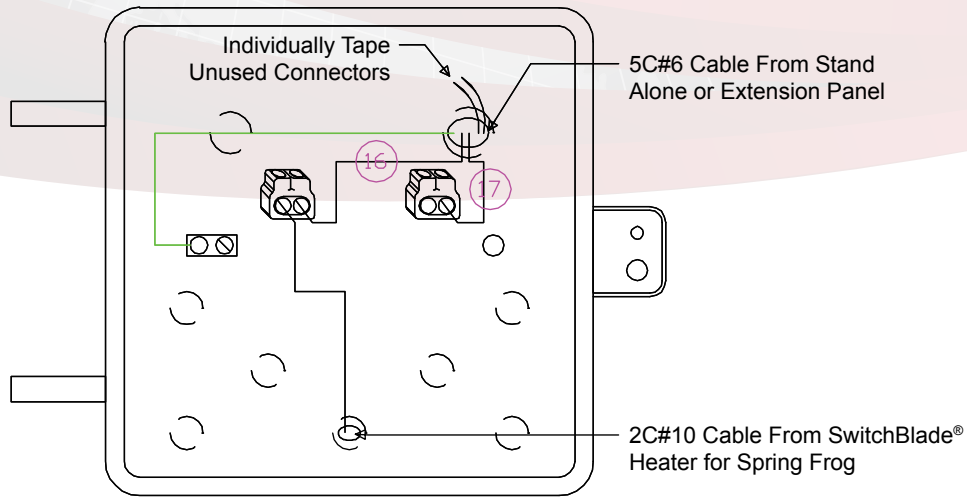


Figure H.14.4 - SwitchBlade® Heater for Spring Frog Typical Connections

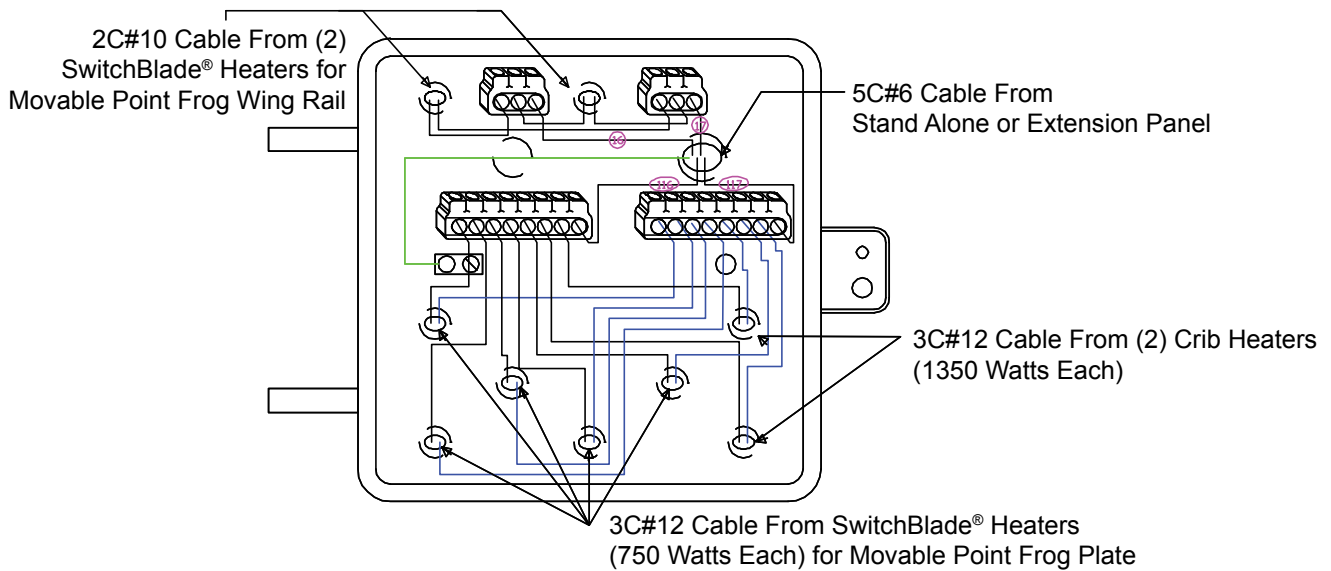
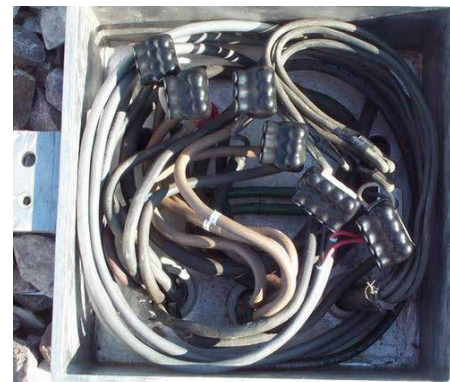


Figure H.14.5 - SwitchBlade® Heater and Crib Heater for Movable Point Frog Typical Connections



Typical Junction Box Cable Entries and Connections

Tape all unused conductors in junction boxes. Square cut, fold back 2" minimum and tape conductor end. Turn wire entry side of insulated connector toward bottom of box after completing connections to prevent moisture build-up.

H.15 FGSP1A GROUND SNOW SENSOR WIRING AT FJAM200SUP JUNCTION BOX

FGSP1A snow sensors are only found at various switch locations as shown in the System Layout section of this manual. If there is no sensor located in your junction box, square cut conductors, fold back a minimum of 2 inches and tape the conductor end.

1. Using (3) 14 AWG previously identified wires, strip each wire 5/8 inch.
2. Pushing each wire into the spring connector provided with the sensor, connect the wires as shown in Figure H.15.2.

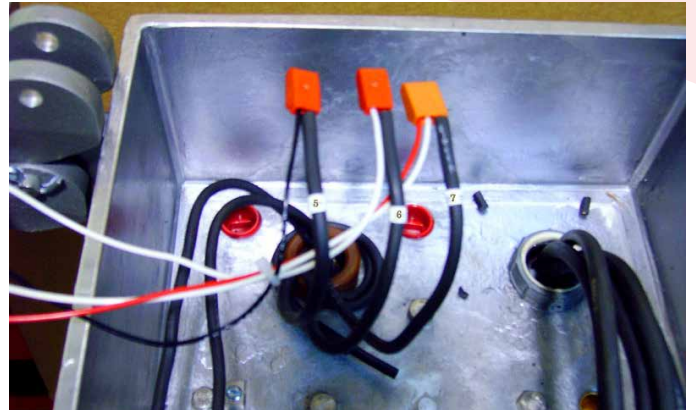


Figure H.15.2 - FGSP1A Junction Box Wire Connections

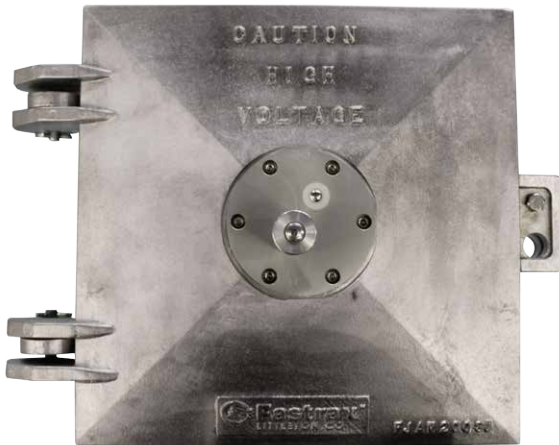


Figure H.15.1 - FGSP1A Ground Snow Sensor

Table H.15-1 Wire Descriptions

Wire Color	Description	Terminal Number
Black	Common	63
White	Signal	64
Red	Supply	65
White	Supply	65

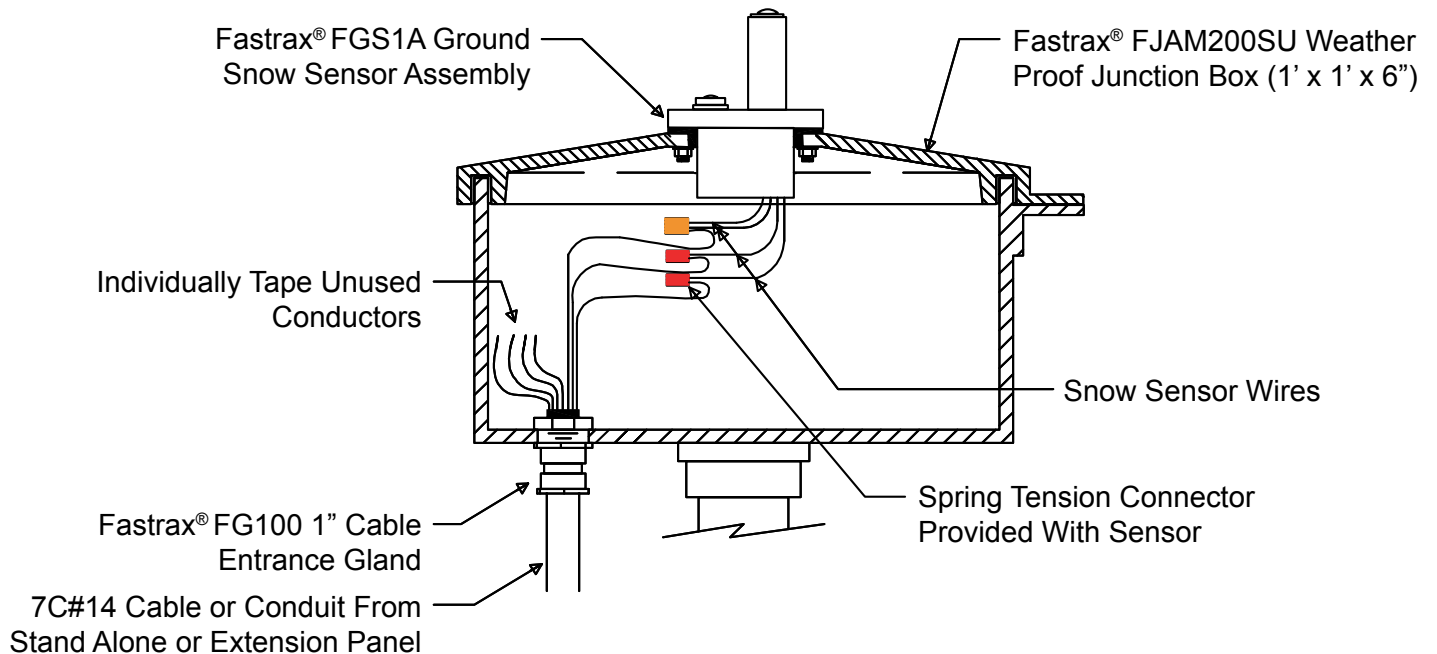


Figure H.15.3 - Junction Box Diagram



Track and Switch Heaters

1500 W. Campus Drive Littleton, Colorado 80120
PH: 855.244.3128 FAX: 303-979-7350
www.fastraxind.com

Photocopy this page for reuse.

DATE:
TECH:

MASTER PANEL
or
STAND ALONE PANEL

Form with sections: PROJECT, LOCATION, CONTACTS, SERIAL NUMBER, MODEL NUMBER, SENSORS, INSTALLATION CHECKOUT, NOTES, OPERATION CHECKOUT, INSTRUCTIONS, TIMER SETTINGS.

IMPORTANT: PLEASE COMPLETE FORMS AND RETURN / COPY TO FASTRAX®



Track and Switch Heaters

1500 W. Campus Drive Littleton, Colorado 80120
 PH: 855.244.3128 FAX: 303-979-7350
www.fastraxind.com



DATE: _____

TECH: _____

STAND ALONE PANEL

SERIAL NUMBER:	MODEL NUMBER:	VOLTAGE:	PH:
		AMPS:	KW:

- OPERATION CHECKOUT**
(QUALIFIED PERSONNEL ONLY)
- INSTRUCTIONS:**
- 1. Disconnect (lockout & tag) all power sources to control panel.
 - 2. Open dead-front panel and turn all heater load circuit breakers in panel to off position.
 - 3. Measure and record the ohm resistance of each heater circuit. Record on form 0004ET. If values vary more than 20% from REF OHMS, check heaters individually.
 - 4. Test megohm values of each heater circuit. If any heater circuit falls below 20 megohms, check heaters individually.
 - 5. With dead-front open, turn disconnect to "on" position. Record input voltages below.
 - 6. Turn on all heater load circuit breakers and turn panel on Full Power. Record main load voltages and amperages below.
 - 7. Ground Fault modules are factory set. No adjustments necessary. To view the trip set-point, open the plastic cover (hinges up). Push the "R" button twice, it should read 30 mA.
 - 8. To test the ground fault press and hold the "T" button until read-out changes. Release the button and in 1 - 3 seconds the module will go into fault. Check that the pilot light (on dead front panel) turned off. Wait 8 - 10 seconds, the GFI will reset.
 - 9. Record ground fault test data below.
 - 10. Turn power "On" and initiate full power to heaters. Record load voltage and amperage for each heater circuit on Form 0004ET.
 - 11. Check voltage and test GFCI 120 volt outlet in dead front when present.
 - 12. Turn panel heater thermostat above ambient temperature. Check heater. Return to 40°F.
 - 13. Test remote dispatch functions.
 - 14. Press red *Stop* button. Close panel. Leave disconnect "On". Secure panel.

INPUT VOLTS: AB	<input style="width: 60px;" type="text"/> VOLTS	BC	<input style="width: 60px;" type="text"/> VOLTS	AC	<input style="width: 60px;" type="text"/> VOLTS
LOAD VOLTS: AB	<input style="width: 60px;" type="text"/> VOLTS	BC	<input style="width: 60px;" type="text"/> VOLTS	AC	<input style="width: 60px;" type="text"/> VOLTS
LOAD AMPS: AB	<input style="width: 60px;" type="text"/> AMPS	BC	<input style="width: 60px;" type="text"/> AMPS	AC	<input style="width: 60px;" type="text"/> AMPS

GFI	mA	PILOT LIGHT	TEST	NOTES	GFI	mA	PILOT LIGHT	TEST	NOTES
NO. 1					NO. 4				
NO. 2					NO. 5				
NO. 3					NO. 6				

NOTES:



Track and Switch Heaters

1500 W. Campus Drive Littleton, Colorado 80120
 PH: 855.244.3128 FAX: 303-979-7350
www.fastraxind.com

CHECK EXTENSION PANELS AND RELATED EQUIPMENT

Photocopy
this page
for reuse.

SLAVE PANEL ___ OF ___

DATE: _____

TECH: _____

**EXTENSION POWER OPERATION
(EACH EXTENSION PANEL)**

SERIAL NUMBER:	MODEL NUMBER:	VOLTAGE:	PH:
		AMPS:	KW:

INSTALLATION CHECKOUT

- | | | |
|---|--------------------------|--|
| <input type="checkbox"/> STRUCTURE | <input type="checkbox"/> | <input type="checkbox"/> LOCK / SECURITY |
| <input type="checkbox"/> ENCLOSURE | <input type="checkbox"/> | <input type="checkbox"/> INSTRUCTIONS |
| <input type="checkbox"/> DRAWING ATTACHED | <input type="checkbox"/> | <input type="checkbox"/> SENSORS |
| <input type="checkbox"/> WIRING - GENERAL | <input type="checkbox"/> | <input type="checkbox"/> FEED TO MASTER |
| <input type="checkbox"/> SERVICE | <input type="checkbox"/> | <input type="checkbox"/> FEEDER |

**OPERATION CHECKOUT
(QUALIFIED PERSONNEL ONLY)**

INSTRUCTIONS:

- 1. Disconnect (lockout & tag) all power sources to control panel.
- 2. Open dead-front panel and turn all heater load circuit breakers in panel to off position.
- 3. Measure and record the ohm resistance of each heater circuit. Record on form 0004ET. If values vary more than 20% from REF OHMS, check heaters individually.
- 4. Test megohm values of each heater circuit. If any heater circuit falls below 20 megohms, check heaters individually.
- 5. With dead-front open, turn disconnect to "on" position. Record input voltages below.
- 6. Turn on all heater load circuit breakers and turn panel on Full Power. At master panel record main load voltages and amperages below.
- 7. Ground fault modules are factory set. No adjustments necessary. To view trip set-point, open plastic cover (hinges up). Push "R" button twice, should read 30 mA.
- 8. To test the ground fault press and hold the "T" button until read-out changes. Release the button and in 1 - 3 seconds the module will go into fault. Check that the pilot light (on dead front panel) turned off. Wait 8 - 10 seconds, the GFI will reset.
- 9. Record ground fault test data below.
- 10. Turn power "On" and initiate full power to heaters. At master panel record load voltage and amperage for each heater circuit on Form 0004ET.
- 11. Check voltage and test GFCI 120 volt outlet in dead front when present.
- 12. Turn panel heater thermostat above ambient temperature. Check heater. Return the thermostat to 40°F.

INPUT VOLTS: AB	<input type="text"/> VOLTS	BC	<input type="text"/> VOLTS	AC	<input type="text"/> VOLTS
LOAD VOLTS: AB	<input type="text"/> VOLTS	BC	<input type="text"/> VOLTS	AC	<input type="text"/> VOLTS
LOAD AMPS: AB	<input type="text"/> AMPS	BC	<input type="text"/> AMPS	AC	<input type="text"/> AMPS

GFI	mA	PILOT LIGHT	TEST	NOTES	GFI	mA	PILOT LIGHT	TEST	NOTES
NO. 1					NO. 4				
NO. 2					NO. 5				
NO. 3					NO. 6				

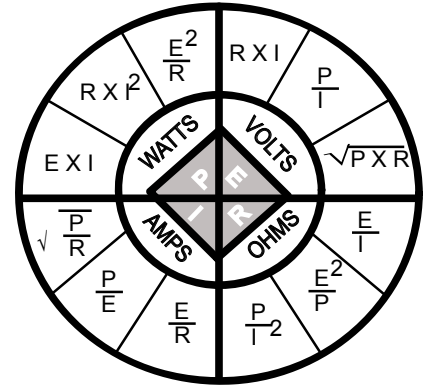
FORM 000452



Track and Switch Heaters

1500 W. Campus Drive Littleton, Colorado 80120-4519
 PH: 855.244.3128 FAX: 303-979-7350
www.fastraxind.com

Ohm's Law



Calculated Circuit Nominal Test Readings

Individual Heaters - Common Sizes
 All Heaters At 300 Watts Per Foot Nominal

HEATER	WATTAGE	240 VOLT		480 VOLT		600 VOLT	
		OHMS	AMPS	OHMS	AMPS	OHMS	AMPS
3 Ft.	750	76.8	3.1	307.2	1.6	480.0	1.3
8 Ft.	2,200	26.2	9.1	104.7	4.6	163.6	3.7
10 Ft.	2,800	20.6	11.7	82.3	5.8	128.6	4.7
12 Ft.	3,400	17.0	14.2	67.8	7.1	105.9	5.7
16 Ft.	4,600	12.5	19.2	50.1	9.9	78.3	7.7
20 Ft.	5,800	9.9	24.2	39.7	12.1	62.1	9.7
26 Ft.	7,600	7.6	31.7	30.3	15.8	47.4	12.7

Individual Heaters - Common Sizes
 All Heaters At 400 Watts Per Foot Nominal

HEATER	WATTAGE	240 VOLT		480 VOLT		600 VOLT	
		OHMS	AMPS	OHMS	AMPS	OHMS	AMPS
8 Ft.	3,000	19.2	12.5	76.8	603.0	120.0	5.0
10 Ft.	3,800	15.2	15.8	60.6	7.9	94.8	6.3
12 Ft.	4,600	12.5	19.2	50.1	9.6	78.3	7.7
16 Ft.	6,200	9.3	25.8	37.2	12.9	58.1	10.3
20 Ft.	7,800	7.4	32.5	29.5	16.3	46.2	13.3
26 Ft.	9,600	6.0	40.0	24.0	20.0	37.5	16.0

Individual Crib Heaters - Common Sizes

HEATER	WATTAGE	120 VOLT		240 VOLT		480 VOLT		600 VOLT	
		OHMS	AMPS	OHMS	AMPS	OHMS	AMPS	OHMS	AMPS
CRIB	700	20.6	5.8	82.3	2.9	329.1	1.5	514.3	1.2
CRIB	1,350	10.7	11.3	42.7	5.6	170.1	2.8	266.7	2.3
CRIB	2,000	7.2	16.7	28.8	8.3	115.2	4.2	180.0	3.4

Combination Of Heaters - Common Parallel Circuit Readings

HEATER COMBINATIONS	WATTAGE	240 VOLT		480 VOLT		600 VOLT	
		OHMS	AMPS	OHMS	AMPS	OHMS	AMPS
(1) 2,200W + (1) 4,600W	6,800	8.5	28.3	33.9	14.2	52.9	11.3
(1) 2,200W + (1) 5,800W	8,000	7.2	33.3	28.7	16.7	45.0	13.3
(1) 2,200W + (1) 7,600W	9,800	5.9	40.8	23.5	20.4	36.7	16.3
(1) 2,200W + (2) 5,800W	13,800	4.1	58.5	16.7	23.8	26.1	23.0
(1) 2,200W + (1) 6,200W	8,400	6.9	35.0	27.4	17.5	42.9	14.0
(1) 2,200W + (1) 7,800W	10,000	5.8	41.7	23.0	20.8	36.0	16.7
(1) 2,200W + (1) 10,200W	12,400	4.6	51.7	18.6	25.8	29.0	20.7
(1) 2,200W + (2) 7,800W	17,800	3.2	74.0	12.9	37.1	20.2	29.7
(2) 1,350 W. CRIBS	2,700	21.3	11.3	85.7	5.6	133.3	4.5
(3) 1,350 W. CRIBS	4,050	14.3	16.8	57.1	8.4	88.9	6.8
(4) 1,350 W. CRIBS	5,400	10.7	22.4	42.9	11.2	66.7	9.0
(5) 1,350 W. CRIBS	6,750	8.5	28.1	34.1	14.1	53.3	11.3
(6) 1,350 W. CRIBS	8,100	7.1	33.8	28.4	16.7	44.4	13.5

Combination of Moveable Point Frog Heaters - Common Parallel Circuit Readings

HEATER COMBINATIONS	WATTAGE	240 VOLT		480 VOLT		600 VOLT	
		OHMS	AMPS	OHMS	AMPS	OHMS	AMPS
(4) 750W + (2) 1,350W	5,700	10.1	23.8	40.4	11.9	63.2	9.5
(2) 3,400W	6,800	8.5	28.3	33.9	14.2	52.9	11.3

I. CONTROL PANEL GENERAL EQUIPMENT PROCEDURES

I.1 MASTER & STAND ALONE PANEL FDC-6/FDC-7 ADJUSTMENT INSTRUCTIONS

FULL POWER TIME SETTING:

1. Push center button to the left. Full power screen appears.
2. Push ALT, then push OK.
3. Move cursor to the digit you wish to change by pushing the center button left or right.
4. Use center button by pushing up or down to change the digit.
5. When all the digits are changed, push OK to save.
6. Screen will return to normal screen 30 seconds after starting.

REDUCED POWER TIME SETTING:

1. Push center button to the right. Reduced power screen appears.
2. Push ALT, then push OK.
3. Move cursor to the digit you wish to change by pushing the center button left or right.
4. Use center button by pushing up or down to change the digit.
5. When all the digits are changed, push OK to save.
6. Screen will return to normal screen 30 seconds after starting.

TO START SYSTEM IN FULL POWER:

1. Push up on the center button while it is in the normal screen. Hold until "Full Power" starts.
2. When the system is in full or reduced power, the normal screen reads:
 - a) Full or reduced power (Depending on what cycle the system is in).
 - b) Set point time for the condition showing.
 - c) Actual time accumulated for that cycle.



Figure I.1.1 - FDC-6/FDC-7 Integrated Control & Sensor System

I.2 STAND ALONE CONTROL PANEL (AUTOMATIC OPERATION)

WHEN AMBIENT TEMPERATURE FALLS BELOW 38°F:

1. Snow or blowing snow exists.
2. Fastrax® FDC-6/FDC-7 automatic snow sensing integrated control and sensor system initiates to full power heater operation.
3. When full power is applied the green "Full Power On" indicating light will be illuminated.
4. The integrated control and sensor system will continue to monitor the environment until no further snowfall is detected or the ambient temperature rises above 38°F.

Note: On control panels heating 3 or more switch assemblies, the heaters are sequenced on in 4 steps with a 10 second delay between heaters coming on.

5. After snowfall stops a timer holds full power on for a period of 1-99 hours (adjustable by customer or default adjustment of 5 hours). Two types of snow sensors are supplied as standard equipment.
 - a) FAS1A aerial snow sensor assembly (field installed above panel).
 - b) FGSP1A ground snow sensor assembly (factory installed in FJAM200SUP junction box).

These snow sensors include a preset 38°F temperature control, a low voltage heater to melt falling snow, and a moisture/snow sensor.

The FDC-6/FDC-7 control system has the ability to accept as many sensors as desired wired to the master control. Any combination of the above sensors may be used. The worst-case location will then turn the system on.

6. After full power time has elapsed the green "Full Power On" indicating light will go off.
7. After 5-7 seconds an energy saving heater circuit energizes, the green "Reduced Power On" indicating light will illuminate, and maintains the rail heaters at 25% of full power to maintain heating of residual or blowing snow.
8. Crib heaters and SwitchBlade® heaters for the spring frog and movable point frog maintain full power during this period.

Note: At any point during the hold time operation (either full or 25% power maintenance cycle) if new snow falls and the ambient temperature falls below 38°F, the automatic control is re-initiated and full heating operation starts over.

I.3 STAND ALONE CONTROL PANEL (MANUAL OPERATION)

1. Manual start operation is a momentary push button on the inner door that initiates the same timed heating cycles as explained in the preceding 'Automatic Operation' section. This push button simulates the snow sensor turning the system on which is a good system test and allows the system to be manually started.
 - a) The green "Manual Start" push button must be held until the green "Full Power" indication light illuminates which generally takes 5-7 seconds.
2. Manual stop is a momentary push button that shuts the control system down if an operator inadvertently starts the system when it is not needed or if system testing is finished.
 - a) Automatic control overrides this stop feature if conditions exist that would initiate the system. In this case, the system shuts down for 5-10 seconds and then will restart in full power.
3. Manual over-ride is a momentary push button that bypasses the automatic equipment and initiates full power to all heating elements.
4. Pressing the black "Manual Over-ride" push button starts a 0-60 hour timer (adjustable by customer or default adjustment of 24 hours) and will illuminate the green "Full Power" indicating light after 5-7 seconds.

Note: On panels heating 3 or more switch assemblies, the heaters are sequenced on in 2 steps with a 5 second delay between heaters coming on. Full power will remain on for the time period regardless of weather conditions. Once the time period is up the system will enter the energy saving cycle and then shut off. To interrupt the over-ride heat cycle, press the red "Manual Stop" push button.

5. If positive shut down of the system is desired turn the disconnect switch mounted on the inner door to the off position. Automatic control will not operate again until the disconnect is returned to the on position. For normal automatic control leave disconnect in the on position.

I.4 ADDITIONAL FEATURES STAND ALONE CONTROL PANEL

REMOTE ANNUNCIATION:

- For single and multiple switch stand-alone panels, terminal 200 & 201 is an annunciation dry contact output for customer use to indicate if the system is on or off. Closed indicates the system is on with no faults, open indicates system is off or in fault.

REMOTE START/STOP:

- The customer can utilize remote start/stop with a maintained dry contact wired into terminals 50 & 70. When the contact closes the system will react the same as if the green "Manual Start" push button is pressed. When the contact opens the control system will shut down unless snow conditions activate the automatic control.

GROUND FAULT PROTECTION:

- Each SwitchBlade® heater is protected with a Ground Fault Interrupter module (GFI) to protect the heating elements and wiring from ground faults. If a fault is detected the system will turn off the power to that switch or frog heating equipment and the amber indicator light will turn off to indicate which switch is in fault. One ground fault module protects all heaters in one complete switch assembly. A separate ground fault module protects all heaters in one complete frog assembly. The system will wait 5 minutes and automatically try to reset the GFI and if the fault has cleared the switch heater will resume in the sequence where it was interrupted. If a fault remains the switch or frog heater will remain off. The system will continue to try and reset every 5 minutes until it resets or an operator repairs the damaged switch heater or associated wiring. If the system is running multiple switches or frogs, only the switch or frog in fault will be disabled and the remaining switches or frogs will continue to function normally.

STROBE LIGHT CIRCUIT:

- Strobe light output (terminals 38 & 39) is a dry contact, which closes if the main disconnect switch, is off or the circuit breakers for the transformer are manually turned off or tripped off.

TIMER ADJUSTMENT:

- Timers can only be adjusted by turning the disconnect switch off and opening up the inner door. Only qualified personnel should perform this task.

I.5 MASTER/EXTENSION CONTROL PANELS (AUTOMATIC OPERATION)

The Master control panel contains most of the control equipment and the extension panel(s) contain the power distribution apparatus.

WHEN AMBIENT TEMPERATURE FALLS BELOW 38°F:

1. Snow or blowing snow exists.
2. The control will be activated. (Internal thermostat controlled heater keeps panel components above freezing during the heating season).
3. Fastrax® FDC-7 automatic snow sensing integrated control and sensor system initiate full power heater operation will continue to monitor the environment until no further snowfall is detected or the ambient temperature rises above 38°F.
4. When full power is applied the green "Full Power On" indicating light will be illuminated.

Note: The extension panels are sequenced on in 4 steps with a 10 second delay between Extensions coming on.

5. After snowfall stops a timer holds full power on for a period of 1-99 hours (adjustable by customer or default adjustment of 5 hours). Two types of snow sensors are supplied as standard equipment.
 - a) FAS1A aerial snow sensor assembly (field installed above panel).
 - b) FGSP1A ground snow sensor assembly (factory installed in FJAM200SUP junction box).

These snow sensor assemblies include a preset 38°F temperature control, a low voltage heater to melt falling snow and a moisture/snow sensor.

The FDC-6/FDC-7 control system has the ability to accept as many sensors as desired wired to the master control. Any combination of the above sensors may be used. The worst-case location will then turn the system on.
6. After full power time has elapsed the green "Full Power On" indicating light will go off.
7. After 5-7 seconds an energy saving heater circuit energizes, the green "Reduced Power On" indicating light will illuminate, and maintains the rail heaters at 25% of full power to maintain heating of residual or blowing snow.
8. Crib heaters and SwitchBlade® heaters for the spring frog and movable point frog maintain full power during this period.

Note: At any point during the hold time operation (either full or 25% power maintenance cycle) if new snow falls and the ambient temperature falls below 38°F, the automatic control is re-initiated and full heating operation starts over.

I.6 MASTER/EXTENSION CONTROL PANELS (MANUAL OPERATION)

The manual controls and timers are located at the Master panel only. The extension panels have annunciation for ground faults only.

1. Manual start operation is a momentary push button (located in the Master panel) on the inner door that initiates the same timed heating cycles as explained in the preceding 'Automatic Operation' section. This push button simulates the snow sensor turning the system on which is a good system test and allows the system to be manually started.
2. The green "Manual Start" push button must be held until the green "Full Power" indication light illuminates which generally takes 5-7 seconds.

Note: The extension panels are sequenced on in 4 steps with a 10 second delay between extensions coming on. Automatic sensing is overridden for initial start up. Automatic control will operate the system once the control cycle is started manually.

3. Manual stop is a momentary push button (located in the Master panel) that shuts the control system down if an operator inadvertently starts the system when it is not needed or if system testing is finished.
 - a) Automatic control overrides this stop feature, if conditions exist that would initiate the system. In this case, the system shuts down for 5-10 seconds and then will restart in full power.
4. Manual over-ride is a momentary push button (located in the Master panel) that will bypass the automatic equipment and initiates full power to all heating elements.
 - a) Pressing the black "Manual Over-ride" push button starts a 0-60 hour timer (adjustable by customer or default adjustment of 24 hours) and will illuminate the green "Full Power" indicating light after 5-7 seconds.
 - b) The extension panels are sequenced on in 2 steps with a 5 second delay between extensions coming on.
 - c) Full power will remain on for the time period regardless of weather conditions. Once the time period is up the system will then shut off.
 - d) To interrupt the over-ride heat cycle press the red "Manual Stop" push button.

5. If positive shut down of the Master system is desired turn the circuit breaker CB1 (located in the Master panel) to the off position.
 - a) Automatic control will not operate again until CB1 is returned to the on position.
 - b) For normal automatic control leave CB1 in the on position.
 - c) For positive shut down of the extension panels, turn the disconnect switch mounted on the inner door of the extension panel to the off position.
 - d) For normal automatic control leave disconnect in the on position.

I.7 ADDITIONAL FEATURES MASTER/EXTENSION CONTROL PANEL

REMOTE ANNUNCIATION:

- Terminal 201 & 211, 202 & 212, 203 & 213, 204 & 214 (located in the Master panel) are annunciation dry contact outputs for customer use to indicate if the extension panels are on or off. Closed indicates the system is on with no faults, open indicates system is off or in fault.

REMOTE START/STOP:

- The customer can utilize remote start/stop with a maintained dry contact wired into terminals 50 & 70 of the Master panel. When the contact closes the system will react the same as if the green "Manual Start" push button is pressed. When the contact opens the control system will shut down.

GROUND FAULT PROTECTION:

- Each SwitchBlade® heater is protected with a Ground Fault Interrupter module (GFI) to protect the heating elements and wiring from ground faults. If a fault is detected the system will turn off the power to that switch or frog heating equipment and the amber indicator light will turn off to indicate which switch is in fault. One ground fault module protects all heaters in one complete switch assembly. A separate ground fault module protects all heaters in one complete frog assembly. The system will wait 5 minutes and automatically try to reset the GFI and if the fault has cleared the switch heater will resume in the sequence where it was interrupted. If a fault remains the switch or frog heater will remain off. The system will continue to try and reset every 5 minutes until it resets or an operator repairs the damaged switch heater or associated wiring. If the system is running multiple switches or frogs, only the switch or frog in fault will be disabled and the remaining switches or frogs will continue to function normally.

STROBE LIGHT CIRCUIT:

- Strobe light output (terminals 38 & 39 in the Master panel) is a dry contact, which closes if the circuit breakers for the transformer are manually turned off or tripped off.

TIMER ADJUSTMENT:

- Timers are located in the Master panel and should be adjusted only by qualified personnel.

I.8 OPTIONS AVAILABLE FOR THE MASTER/EXTENSION CONTROL PANEL

(Contact engineering or Fastrax®)

- Painted steel enclosure for NEMA 12 installations indoors.
- Sequence individual or groups of heaters on start up for multiple heater installations.
- SCR power switching.
- Temperature sensor – rail mounted (thermocouple or RTD)

I.9 MAINTENANCE



Hazard of electric shock. Disconnect all power to panel before servicing. Only qualified personnel trained in electrical equipment service should perform maintenance on switch heating and control equipment.

1. Visually check the panel for external physical damage. Repair or replace as necessary.
2. Check all field load terminations annually and tighten to torque specified on attached torque chart.
3. Visually inspect internal components for wear or deterioration. Replace as necessary. Consult Fastrax® for replacement parts.
4. Inspect sensor for dirt, grease or any conductive debris making contact with moisture sensing button. If dirt or conductive film is present clean unit with a mild detergent.
5. Test the external FAS1A and FGSP1A snow sensors annually using the following procedure:

Tools Needed: Volt meter, Freeze spray and water.

6. Ensure that the control panels used with the snow sensors are energized and performing correctly.
7. Ensure that the moisture-sensing grid on the FAS1A and the contact surfaces on the FGSP1A are clean and dry.
8. Connect the voltmeter across the black and red leads from the sensor (terminals 60 and 62 at the load terminal blocks. Normal reading is 24-28 volts AC.

9. Now connect the voltmeter across the black and white sensor leads (terminals 60 and 61 at the panel terminal blocks). Normal reading of 0 volts AC should appear with a clean dry sensor at 38°F or greater.
10. Cool the temperature probe of FAS1A snow sensor with the freeze spray and wet the grid with water. Normal voltmeter reading should be 24-28 volts AC across the black and white terminals (60 & 61) within 1 minute.
11. Let the grid dry. (The internal sensor heater will accomplish this given time.) The voltage reading should return to 0 volts AC.
12. Repeat steps 1-11 to test the FGSP1A snow sensor (terminal blocks 63, 64 and 65).
13. If any of the above conditions are not met, the sensor may be damaged. Consult Fastrax® for assistance.
14. Test ground fault circuit breaker by tripping internal test button or lever.

Note: If panel does not function properly or does not operate as specified, disconnect power from the panel and contact Fastrax® for assistance.

FOR GENERAL OPERATION AND MAINTENANCE GUIDE SEE FAS1A SYSTEM INSPECTION REQUIREMENT DOCUMENT.

TORQUE SPECIFICATION

CAUTION: Before testing tightness of any electrical connection disconnect electrical feeder to control panel to ensure entire panel is deenergized

ELECTRICAL EQUIPMENT CLAMP / SCREW TORQUE VALUES

Part Type	Description	Torque (in/lb)
Terminals	Control Circuits	9
Terminals	Crib Heater Circuits	10
Terminals	Heater Load Circuits	16
Terminals	Ground Block Terminals	12
Disconnect	Up To 100 Amperes	50
Disconnect	100 To 200 Amperes	200
Disconnect	400 Amperes	375
Contactors	Pressure Plate Lugs	15 - 20
Contactors	Box Lugs	40 - 45
Pwr. Dist. Block	Primary	120
Pwr. Dist. Block	Secondary	45
Circuit Breakers	Heater And Control Loads	17.7

STANDARD EQUIPMENT SELECTION

I.10 SWITCHBLADE® HEATING

Contact Fastrax® or review the bill of material for proper heater selection.

1.0 If necessary, follow the steps below:

1. Determine switch and heater size. Use the following guideline for selecting heater length:
 - Measure from switch point to center line of heel block.
 - Consult Bill of Material for standard heater sizes.
 - Select heater overall length to cover switch length from standard sizes.
 - Installation standard is on the field side of the rail. Two stock rail and two moving rail heaters are required for each standard switch up to a No. 15 in size. Two additional stock rail heaters are required for No. 20 size switches. See Layout Section in this manual.
2. Select crib heaters for each switch as required or if drainage is not adequate during winter months. Select 8 ft 8", 1,350 watt crib heaters standard or 7 ft, 1,350 watt crib heaters if space restricts the length of unit to be installed.

I.11 SPRING FROG HEATING

1.0 Follow the steps below:

1. Determine spring frog type:
 - Retrofit type has continuous clearance below horn bolts and does not have milled channel in the frog base.
 - New style has milled channel in the frog base.
2. Determine heater size:
 - Verify length of retrofit spring frog by measuring clear length of D-bar. D-bar should be of sufficient length to provide surface contact for entire heater length.
 - Verify length of new spring frog with milled channel by inserting fish tape in channel and measuring channel length. Frog heater length must not exceed channel length.
 - Select appropriate frog heater from bill of material.

Note: If frog does not have proper heater clearance or is not a size listed contact engineering or Fastrax® for optional installation methods.

I.12 MOVABLE POINT FROG HEATING

Contact Fastrax or review the bill of material for proper movable point frog heater selection.

J. PROCEDURES

J.1 GENERAL OPERATION

GENERAL OPERATION

1. Fastrax® Switchblade® style track switch, crib heaters, spring frog rail heaters and movable point frog heaters are engineered for state of the art heat transference and are ruggedly designed and constructed for endurance.
2. When properly installed, operated and maintained, they will provide long life and dependable, trouble-free service. The flattened stainless steel heater style is extremely efficient and durable.
3. When energized at the rated voltage, each heater will operate at the nameplate wattage and transfer heat to the rail or crib area it is attached to.
4. Flat heaters are attached to the rail or crib platform with XTC spring style clamp assemblies that will expand and contract while maintaining excellent contact with the metal and readily transfer heat bringing the rail or platform above freezing temperatures.
5. Once above freezing, the heat from the rail or platform will radiate warmth to melt existing or accumulating snow and ice in the track switch, spring frog wing, movable point frog rail, or crib area.
6. When controlled with a Fastrax® control panel system the switch heaters will operate in an energy saving mode but only after snow has stopped falling.
7. The energy saving mode will continue to operate the spring frog, movable point frog and crib heaters at full nameplate rated wattage while the switch heaters will function at 25% of their rated wattage for an adjustable time period.
8. If snow begins to fall again all heaters automatically return to full output.

J.2 INSTALLATION PROCEDURE

Note: Do not operate heaters at voltages in excess of that stamped on the heater. Excess voltage will shorten heater life.

1.0 SWITCHBLADE® AND CRIB HEATERS

1. Switch Heaters:

- After equipment selection is made and installation side of rail is determined, reference the System Layout and Rail Heater sections (page 9) of this manual. When installing heaters, they should be located on the rail web extending from a point approximately 2 ft ahead of the switch toward the heel block.

2. SwitchBlade® Heater Clamp Positioning:

- Layout the proper clamp locations for the heaters. Be certain that clamp locations are placed approximately 24" on center following the Rail Heater section of this manual
- Avoid locating clamps where braces, signal wires, or other apparatus is blocking access to the rail web.
- If existing braces are not of the notched style as shown in drawings
- Replace braces with the notched style or contact engineering or Fastrax Industries for optional installation methods.

3. SwitchBlade® Heater Clamping:

- Type FRB600 spring base style rail clamps should be used to allow the heater to maintain close contact with the rail while permitting normal expansion and contraction. Install clamps by hand and assemble on heater as described in the Rail Heater section of this manual.

4. Crib Heaters:

- Clear ballast from between the ties below the switch rods. Allow for a minimum of 4" from the base of the rail to the top of the FCH Crib Heater platform. Always mount top of Crib Heater platform to allow proper clearance for free operation of switch rods. Place heater platform in the desired position to maintain a snow and ice-free area below the operating switch rods. Install as outlined in the Crib Heater section of this manual. Replace ballast in area around crib heater.

5. SwitchBlade® Heaters for Frog:

- Install all frog heaters as covered in this manual.

2.0 ALL HEATER POWER LEADS

Reference details shown in this manual for direct burial of heater power conductor. Fasten as shown. Direct power leads below ballast to prohibit tripping hazard. Route leads to proper junction box as covered in System Wiring section of this manual.

1. Wiring and Connections:



Hazard of electrical shock. When electric heaters are applied to track switches where track circuits are used in conjunction with signal or switch operation and it is necessary that power system be maintained free from grounds, suitable ground fault detection and interrupting systems must be in use at all times to reduce shock hazard and protect signal system.

- Electric wiring to heating elements must be installed in accordance with National Electrical Code (NFPA 70) and any applicable third party standards.
- Use approved wiring accessories as listed on bill of materials.
- Leads between heater and junction boxes should be located so as to minimize possible damage.
- Electrical lead terminations shall be located in approved style FJA junction boxes rated for the area of service. Torque wire connections as specified.
- Install minimum AWG heater conductor size to control panel terminals. Connect as shown on reference drawings.

- It is recommended that switch heaters be tested annually for proper insulation resistance. Turn off the breakers feeding the heaters and test insulation resistance at the incoming terminal blocks with a 500 Volt DC Meg Ohm Meter. A minimum value of 20 Meg Ohms should be obtained between heater metal sheath and electrical conductors. If this insulation level is not achieved, leave heaters disconnected and contact Fastrax®.
- Periodically check heater-mounting hardware for loose or missing clamps - tighten or replace as needed. It is important that heating element surface maintains close contact with rail to insure long life and maximum efficiency.
- Inspect heater and ensure that heater is secured and flat on the rail web.
- Visually check heaters regularly to keep debris, combustible materials, and other objects from lying against or lodging between the heater and the rail.
- Visually check heaters regularly for signs of physical damage from abnormal circumstances. If physical damage is apparent, disconnect and perform insulation test immediately before placing the heater back in service.



DO NOT attempt to disassemble any component of this heater.

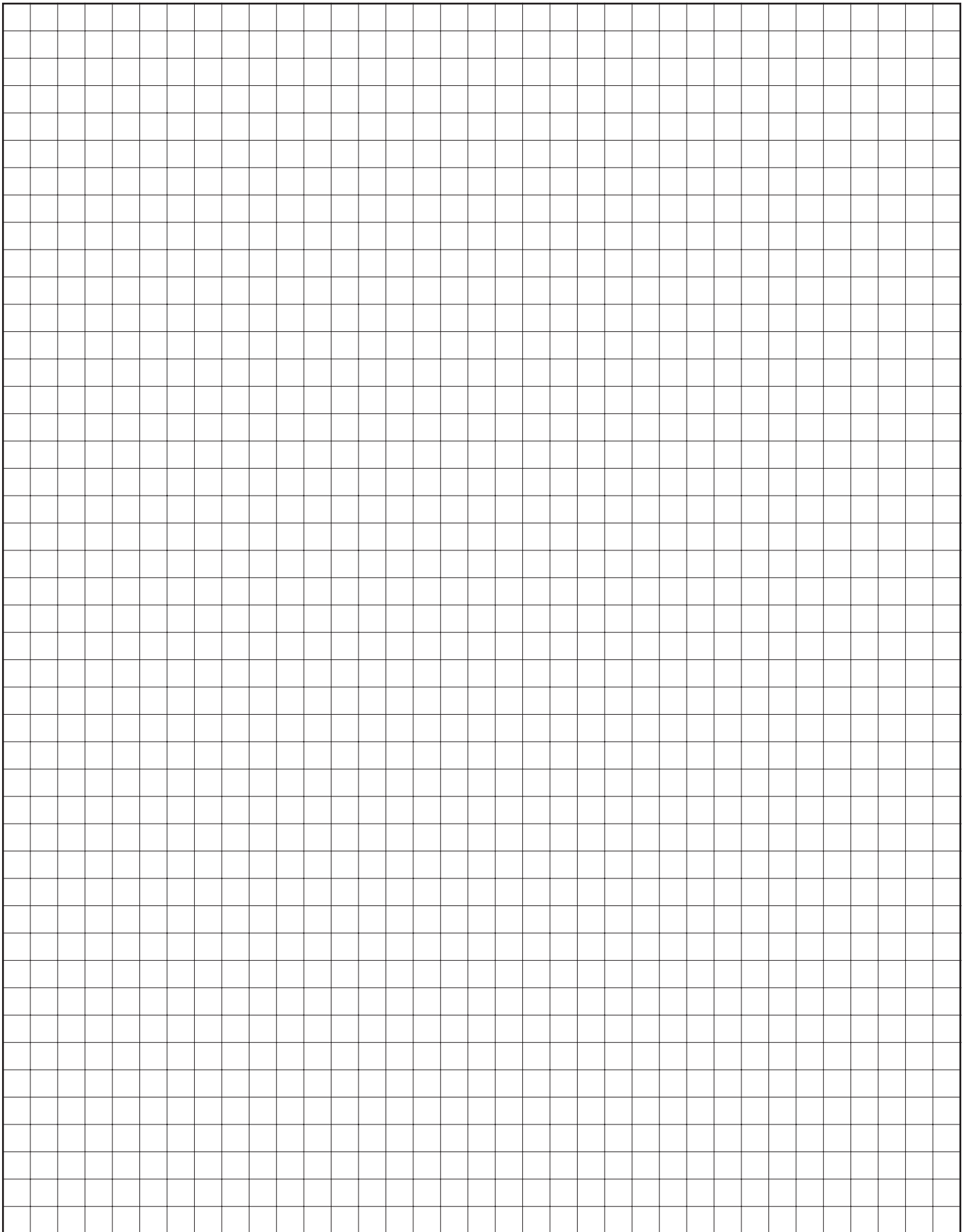
J.3 MAINTENANCE PROCEDURE



Hazard of severe shock. Disconnect all power to heaters before servicing or replacing heaters. Only qualified personnel trained in electrical equipment service should perform maintenance on switch heating and control equipment.

- Periodically (minimum annual) check connection of the electrical terminals and tighten if necessary to torque specification guides.

NOTES





As a leader in advanced heating and filtration solutions with facilities across North America, CCI Thermal Technologies Inc. manufactures six of the top brands in industrial heating in addition to a comprehensive line of engineered industrial filtration products including:



Cata-Dyne™ is the industry standard in infrared gas catalytic heaters, enclosures, pipeline systems and accessories. Customers across a wide range of industries rely on Cata-Dyne™ to supply them with safe, reliable, efficient and versatile infrared catalytic heating equipment for a variety of applications in both hazardous and non-hazardous environments.

Ruffneck™ is renowned for its rugged, reliable and versatile heavy-duty explosion-proof heaters, heating systems and heating accessories. Ruffneck™ has a long and proud history of supplying quality heating products for the harshest industrial environments to a worldwide customer base for over 30 years. Ruffneck™ is well-known in the industry for its "ship the heat in a week" policy, where 95% of all standard orders are shipped within one week of order placement.



Caloritech™ electric heaters, heating elements and heating accessories are well-known in the industry for their quality, reliability, performance and versatility. In addition to standard "off the shelf" industrial heaters and heating systems components, Caloritech™ also offers engineered heating solutions custom designed, manufactured and tested to satisfy customer specifications. No matter what your application or environment, Caloritech™ has a solution to fit your heating needs.

3L Filters™ has satisfied the most demanding industrial filtration requirements for over 40 years. A broad range of standard and custom products includes liquid filters, strainers, separators, pressure vessels, and engineered products and systems. 3L Filters™ has special expertise for nuclear, petrochemical, water treatment and environmental applications.



Norseman™ is the most technologically advanced line of explosion-proof electric air heaters and heating accessories, including both forced air heaters and natural convection heaters, as well as unit heaters, panel heaters and thermostats. Norseman™ offers innovative, low maintenance solutions for a wide range of applications in a variety of industrial and commercial environments. Custom engineered heaters or heating systems are available for specialized applications.

Fastrax® has manufactured railroad track and switch heating since 1995. Fastrax® engineers complete heating packages for the rail industry. Fastrax® track and switch heaters are designed to provide the most efficient heat transfer on rail equipment and components for the coldest environments. In addition to heaters, Fastrax® manufactures fully automatic energy saving controls to complete the rail heating system.



DriQuik™ provides components for infrared drying ovens. DriQuik™ utilizes a pioneered radiant oven technology established in the 1930s providing the industry standard in infrared radiant heating components.

VISIT WWW.CCITHERMAL.COM FOR DETAILED PRODUCT INFORMATION.

Edmonton, AB

Head Office
1-800-661-8529
(780) 466-3178
F 780-468-5904

Oakville, ON

1-800-410-3131
(905) 829-4422
F 905-829-4430

Orillia, ON

1-877-325-3473
(705) 325-3473
F 705-325-2106

Houston, TX

1-855-219-2101
(281) 506-2310
F 281-506-2316

Denver, CO

1-855-244-3128
(303) 979-7339
F 303-979-7350