

ECN 7975
ECN 8741
ECN 9334
ECN 9531
ECN 9681
ECN 19873

MANUAL
81-M-15
Feb. 1981 - Rev. Apr.'00
Issue Sept.'02

Installation and Maintenance Manual for Orbit Spring-Close, LS Series CYLINDER ACTUATORS AND ACCESSORIES



ORBIT VALVE

A DIVISION OF COOPER CAMERON VALVES

P.O. Box 193520 • Little Rock, Arkansas 72119 • U.S.A.
Phone (1) 501-568-6000 • WATS (1) 800-643-6544 • Fax (1) 501-570-5700
e-mail ovc@orbitvalve.com • website: www.orbitvalve.com

THIS MANUAL COVERS THE FOLLOWING CYLINDER ACTUATOR FIGURE NUMBERS:

LS-124-D-2-X-S -3-X-S -4-X-S -12-X-S -13-X-S -14-X-S -20-X-S -21-X-S -22-X-S -23-X-S -24-X-S -25-X-S -26-X-S -27-X-S	LS-124-D-20-N-S -21-N-S -22-N-S -23-N-S -24-N-S -25-N-S -26-N-S -27-N-S	LS-124-D-2-M-S -3-M-S -4-M-S -12-M-S -13-M-S -14-M-S -20-M-S -21-M-S -22-M-S -23-M-S -24-M-S -25-M-S -26-M-S -27-M-S	LS-185-D-4-X-S -5-X-S -14-X-S -15-X-S -20-X-S -25-X-S -26-X-S LS-185-D-4-M-S -5-M-S -14-M-S -15-M-S -20-M-S -25-M-S -26-M-S	LS-185-D-20-N-S -23-N-S -24-N-S -25-N-S -26-N-S	LS-205-D-5-X-S -6-X-S -15-X-S -16-X-S -26-X-S LS-205-D-5-M-S -6-M-S -15-M-S -16-M-S
---	--	---	--	---	---

CONTENTS

Cylinder Actuator Identification	3
Operation of Spring-Close Actuators	4
Optional Two-Way Manual Mechanism	5
INSTALLATION	
Installation of Actuator/Valve Combination	7
Actuator Operating Parameter Chart	9
Conversion of Handwheel Operated Valves to Actuator Operated Valves	
Valve Model Identification	11
Actuator Mounting on “L” Valves ①	
Valve Model Identification	11
Indicator Plates (Installation & Adjustment)	52
Nominal Valve Stroke Chart	53
Spring Compression Adjustment	54
ACTUATOR REPAIR ②	
Actuator Removal From Valve	57
Gas-Over-Oil Tank and Piping Removal & Installation	59
Disassembly of Spring-Close Actuator (LS-124, LS-185, LS-205)	63
Assembly Of Spring-Close Actuator (LS-124, LS-185, LS-205)	68
Disassembly of Spring-Close Actuator with Two-Way Mechanism (LS-124, LS-185)	72
Assembly Of Spring-Close Actuator with Two-Way Mechanism (LS-124, LS-185)	78
Disassembly Of Spring-Close Actuator with Two-Way Mechanism (LS-205)	82
Assembly Of Spring-Close Actuator with Two-Way Mechanism (LS-205)	87
Actuator Conversions	90
MAINTENANCE	
Lubrication Schedule	91
Lubrication Points	91
Recommended Lubricants	92
Gas-Over-Oil Tank Fluid Level	92
ACCESSORIES	
Instrumentation Panels	93
Pressure Reserve Tank (Accumulator)	94
Electric CX Switch	
Installation	95
Removal	97
Adjustment	97
APPENDIX	
Actuator mounting dimensions	98
Conversion factors	98

NOTES: ① An “L” Valve is an Orbit term used to define a valve which is ready for actuator attachment. (The handwheel assembly has been removed and any adapter flanges, if required, are installed on the valve bonnet.) The “L” does not appear as a prefix or suffix to the valve serial number.

② Alignment tool **Z-2886** is required to reassemble the actuator. Order tool when ordering replacement parts.

CYLINDER ACTUATOR IDENTIFICATION

Identification of the actuator figure number is needed for installation and/ or repair purposes. The actuator figure number is stamped on the valve/actuator nameplate. See Figure 1 for nameplate identification and location.

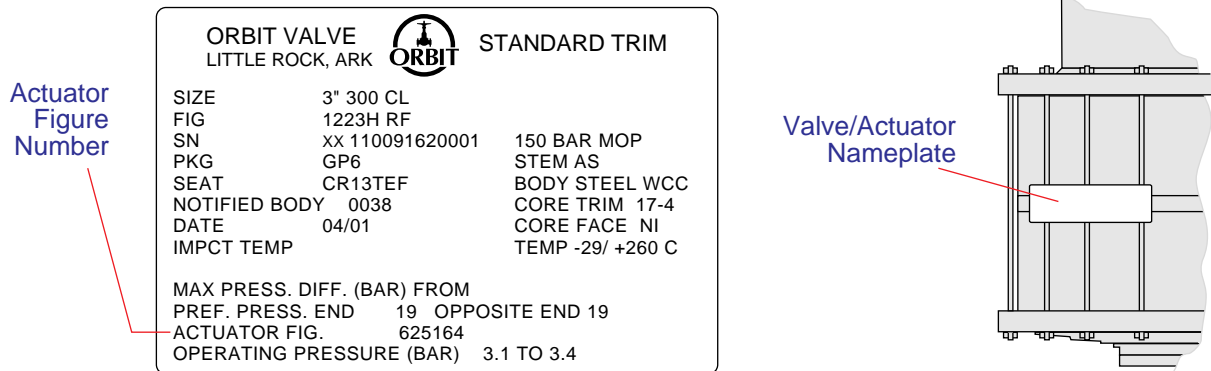

FIGURE 1
Nameplate Identification and Location

WARNING:

DO NOT USE THIS MANUAL FOR ORBIT LG SERIES ACTUATORS.

Unexpected pressure could be encountered.

Use Manual 79-M-13 for LG series spring close actuators.

FOR ORBIT DOUBLE ACTING CYLINDER ACTUATORS:

Use Manual 79-M-11 for LG series or use Manual 81-M-14 for LS series.

If the nameplate is missing or illegible, the Orbit actuator figure number may be identified by tracing the valve serial number back to its original order. The Little Rock factory maintains file records by valve serial number.

To reach the factory, call 1-800-643-6544 (within the USA). Allow a reasonable amount of time for the serial number to be traced.

See Figure 2 below for the serial number locations.

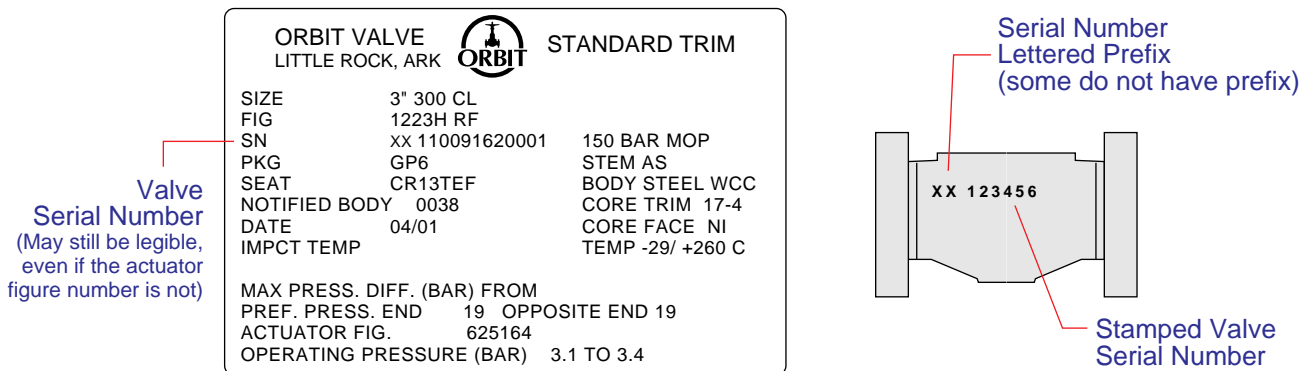

FIGURE 2
Valve Serial Number Locations

OPERATION OF SPRING-CLOSE ACTUATOR

Refer to Figure 3.

The Orbit spring-close cylinder actuator is used for remote operation of Orbit valves.

Operation is accomplished by pressurizing the actuator to open the valve and depressurizing to close. A compression spring is used to create the force to close the valve/actuator and gas (air) pressure working on the opening side of the actuator pistons is used to create the force to open the valve/actuator.

WARNING:

Avoid bleeding pressure from the actuator while valve is in service, unless valve closure is desired. Loss of pressure will cause the valve to close.

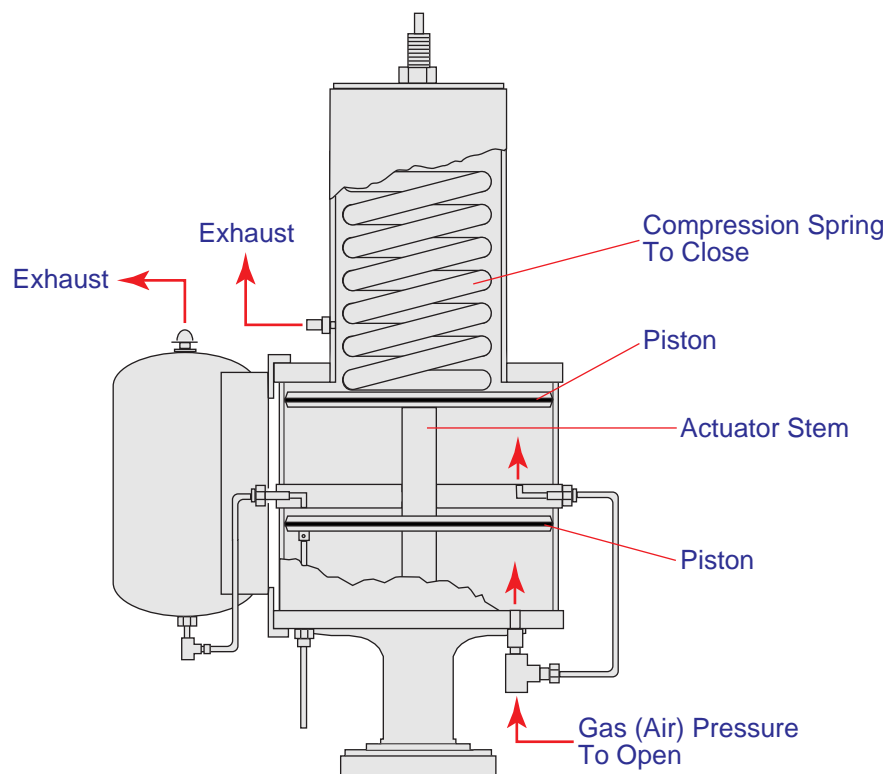

FIGURE 3

Spring-Close Cylinder Actuator Operation

OPTIONAL TWO-WAY MANUAL MECHANISM OPERATION

Refer to Figure 4.

The two-way manual mechanism is used to lock the valve in either the open or closed position, to manually open the valve if gas pressure to the actuator is lost, or to manually close the valve if spring failure occurs.

OPERATION OF SPRING-CLOSE ACTUATOR, continued

LS-124 & 185 ACTUATORS (TYPE -M-)

NORMAL OPERATING POSITION: Spring-to-close and gas (air) pressure to open. The bottom of the handwheel is adjusted so that it is just touching the top of the neutral position indicator gage and the jam nut is tightened against the top of the spring housing.

- ①② To **MANUALLY OPEN** the valve, the jam nut is loosened and the handwheel is turned counterclockwise ↺ until the valve is opened.
- ①② To **MANUALLY CLOSE** the valve, the jam nut is loosened, the gas (air) pressure is bled from the actuator and the handwheel is turned clockwise ↻, until the valve is closed.
 - ② To **LOCK OPEN** the valve, when the valve is open, loosen the jam nut and turn the handwheel counterclockwise ↺ until positive resistance is met.
 - ② To **LOCK CLOSE** the valve, when the valve is closed, loosen the jam nut and turn the handwheel clockwise ↻ until positive resistance is met.

LS-124 & 185 ACTUATORS (TYPE -N-)

NORMAL OPERATING POSITION: Spring-to-close and gas (air) pressure to open. The lock pin is installed in the manual open position, as shown in the figure.

- ①② To **MANUALLY OPEN** the valve, the lock pin is removed and the handwheel is turned counterclockwise ↺ until the valve is opened.
- ①② To **MANUALLY CLOSE** the valve, the lock pin is removed, the gas (air) pressure is bled from the actuator and the handwheel is turned clockwise ↻ until the valve is closed.
 - ② To **LOCK OPEN** the valve, when the valve is open, remove the lock pin and turn the handwheel counterclockwise ↺ until positive resistance is met.
 - ② To **LOCK CLOSE** the valve, when the valve is closed, remove the lock pin and turn the handwheel clockwise ↻ until positive resistance is met.

LS-205 ACTUATOR

NORMAL OPERATING POSITION: Spring-to-close and gas (air) pressure to open. The handwheel is adjusted so the indicator rod is even with the neutral position indicator.

- ①② To **MANUALLY OPEN** the valve, the handwheel is turned counterclockwise ↺ until the valve opens.
- ①② To **MANUALLY CLOSE** the valve, the gas (air) pressure is bled from the actuator and the handwheel is turned clockwise ↻ until the valve closes.
 - ② To **LOCK OPEN** the valve, when the valve is open, turn the handwheel counterclockwise ↺ until positive resistance is met.
 - ② To **LOCK CLOSE** the valve, when the valve is closed, turn the handwheel clockwise ↻ until positive resistance is met.

- NOTES:**
- ① The valve is locked in this position until the actuator is returned to normal operating position.
 - ② Excessive handwheel torque is not required. DO NOT use cheater bars on the handwheel.

OPERATION OF SPRING-CLOSE ACTUATOR, continued

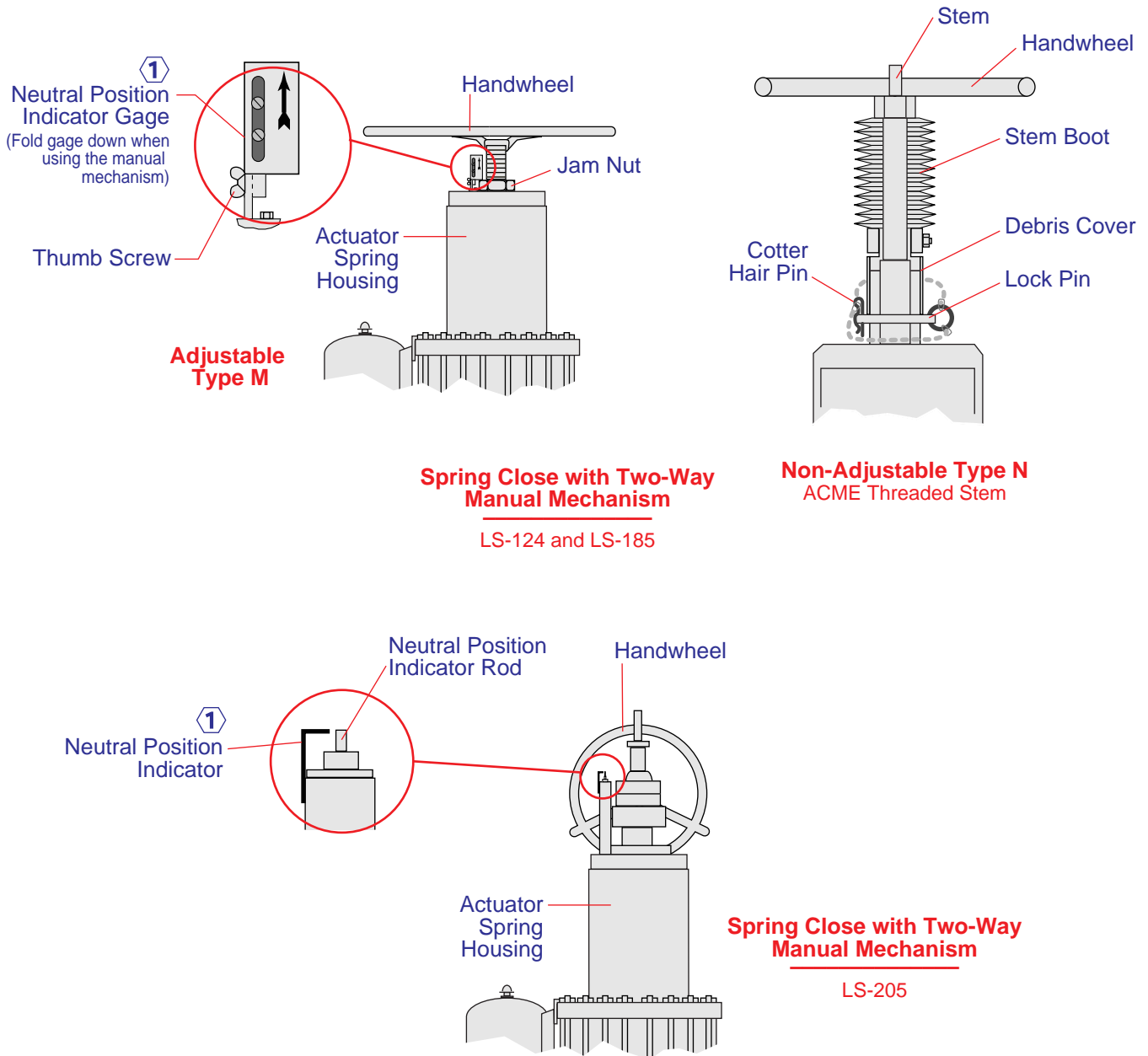

FIGURE 4
Optional Two-Way Manual Mechanism Operation

NOTE: ① Preset at factory - Do not readjust unless spring compression has been readjusted.

INSTALLATION

The spring-close cylinder actuator is normally mounted on the valve at the factory, but may be field mounted.

WARNING: Two lifting lugs are provided on the top of the actuator. These should be used when handling the actuator, to prevent damage to the equipment and injury to personnel.

INSTALLATION OF ACTUATOR / VALVE COMBINATION

1. Install the valve/actuator combination in the pipeline so the PREFERRED PRESSURE END will be exposed to the higher pressure when the valve is closed. See Figure 5.

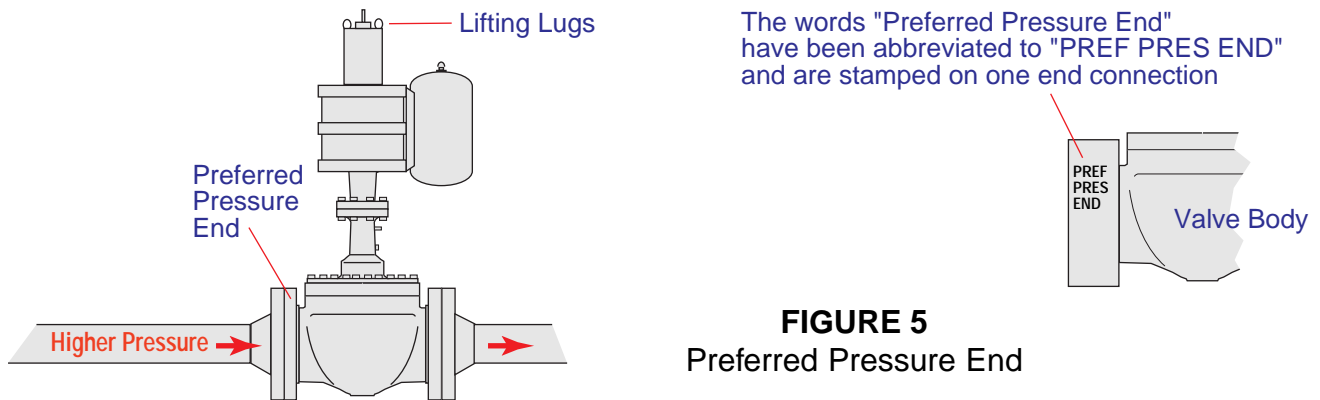

2. Check that the gas-over-oil tank is mounted in the vertical position. See Figure 6 for illustrations of the basic tank positions.

NOTE:

The gas-over-oil tank will be attached at the factory for a horizontal pipeline with the valve stem in the vertical position, unless otherwise specified by the customer.

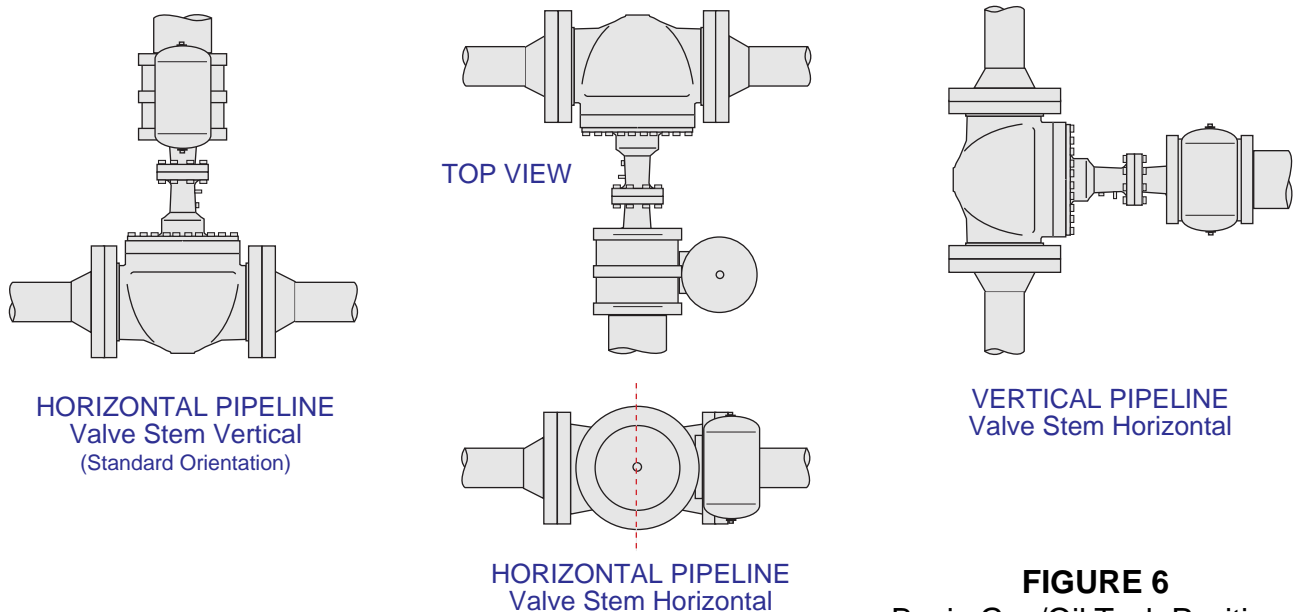

INSTALLATION, continued

- Connect the opening gas (air) supply pressure line (3/8 NPT for LS-124 & LS-185; 1/2 NPT for LS-205 actuators). See Figure 7 for connection location.

WARNING: A regulated gas (air) supply with flow controls must be used to regulate the pressure and operating speed, to prevent damage to the equipment.

If optional instrumentation is provided, see the applicable SUGGESTED PIPING ARRANGEMENT drawing for connection to the gas (air) supply.

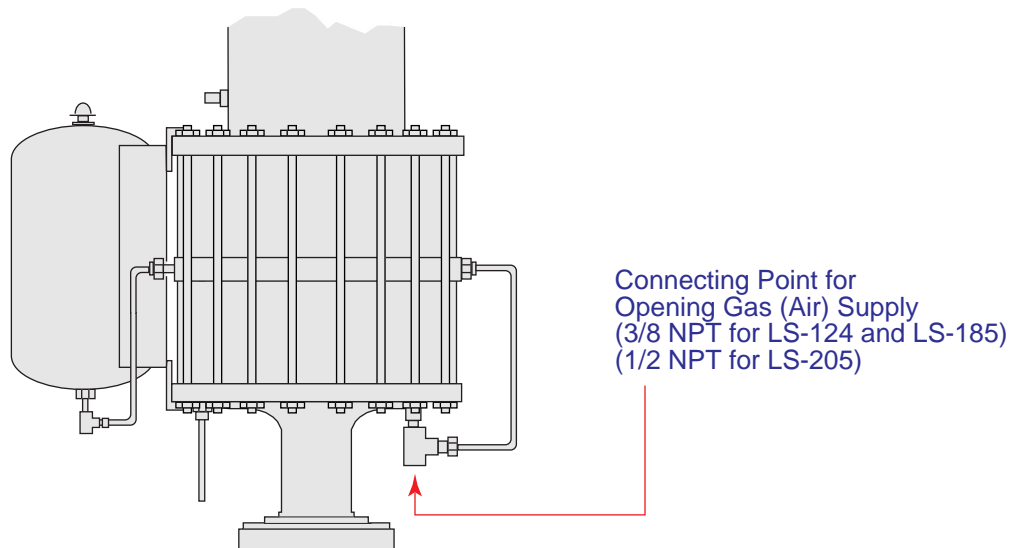

FIGURE 7
Gas (Air) Connection

- Read all nameplates, warning tags, and any instruction tags before pressurizing the actuator. See Figure 8 for valve/actuator nameplate location.

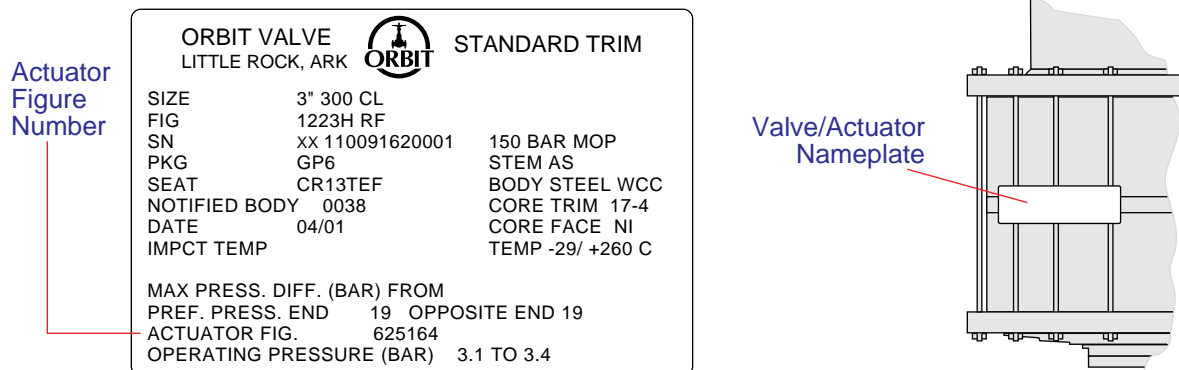

FIGURE 8
Valve/Actuator Nameplate

INSTALLATION, continued

5. Be sure that a sufficient volume of gas (air), at a suitable pressure, is available to operate the actuator. Adjust the operating pressure to the actuator to the specified pressure on the valve/actuator nameplate (see Figure 8). Adjust the closing time of the valve/actuator so that it is not faster than the recommended time given in the chart below. (Note: Faster times may cause damage to the valve and actuator.)

NOTE:

On field mounted actuators, the spring-compression must be adjusted. See the “Spring Compression Adjustment” section in this manual (Page 54).

The chart below gives actuator operating parameters:

ACTUATOR FIGURE NO.	① Operating Pressure		② Gas Vol. / Cycle Req'd.		③ Closing Time
	PSIG	Bars	Cubic Feet	Cubic Meters	Seconds
LS-124-D-2 / 12 / 21 / 22-XS / MS / NS	75-80	5.2-5.5	2.3	.065	25-40
LS- 124-D-3 / 4 / 13 / 14 / 23 / 24 / 25 / 26-XS / MS / NS	75-80	5.2-5.5	2.9	.082	25-40
LS-124-D-20-XS / MS / NS	75-80	5.2-5.5	2.5	.071	25-40
LS-124-D-27-XS / MS / NS	75-80	5.2-5.5	2.0	.057	25-40
LS-185-D-4 / 14-XS-MS / 25 / 26-XS / MS / NS	75-80	5.2-5.5	6.0	.170	35-50
LS-185-D-5 / 15-XS / MS	75-80	5.2-5.5	7.5	.212	35-50
LS-185-D-20-XS / MS / NS	75-80	5.2-5.5	5.1	.144	35-50
LS-205-D-5 / 15-XS / MS	75-80	5.2-5.5	9.6	.272	50-70
LS- 205-D-6 / 16-XS / MS	75-80	5.2-5.5	10.7	.303	50-70

① Use pressure stamped on valve / actuator nameplate, if different from listed pressure. See Figure 8 for location of nameplate.

② Approximate gas volume required to open valve (spring-to-close) at 70°F (21.1°C) and maximum operating pressure.

③ Recommended closing time may be slower but should not be faster. Speed can be adjusted by using a flow control in the exhaust port of the actuator control valve.

6. Check the oil level in the gas-over-oil tank as described in the “MAINTENANCE” section of this manual (page 92). If the actuator has been repaired or stored for more than three (3) months, lubricate as described in the “MAINTENANCE” section of this manual (page 91).

INSTALLATION, continued

7. Check the operation of the actuator/valve. This can be accomplished by cycling the actuator/valve two or three times and observing that the pointer on the VPI rod is over the bright band on the indicator plates in the open and closed position. See Figure 9.

NOTE:

On field mounted actuators, the open and closed indicator plates must be adjusted. See the "Indicator Plate (Installation and Adjustment)" section on page 52.

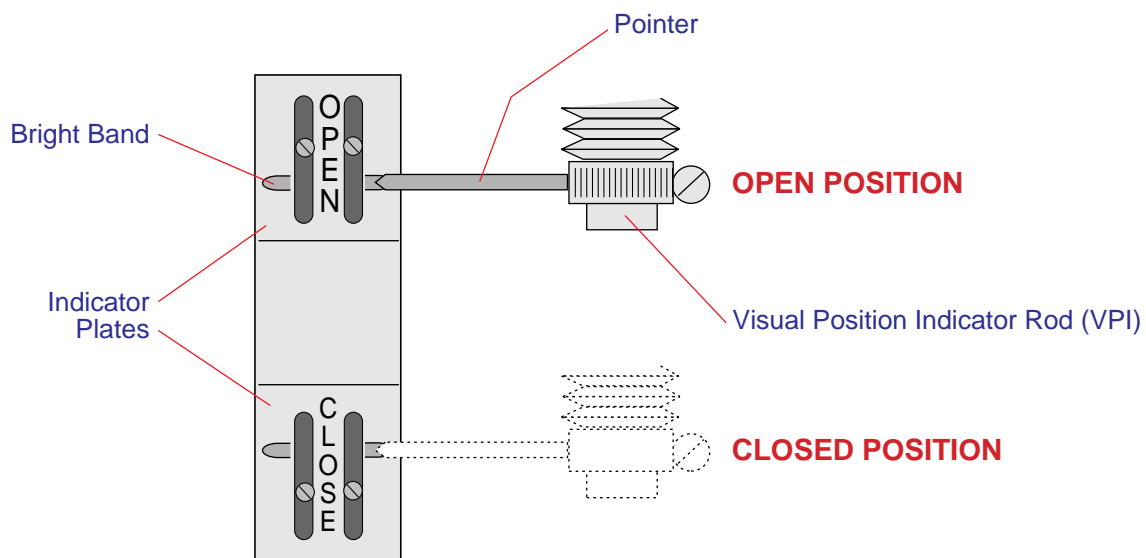

FIGURE 9
Pointer Position

8. Verify that all accessories, such as switches, operate properly. Make adjustments as necessary.
9. The installation is completed and ready for an initial system test and online operation.

INSTALLATION, continued

CONVERSION OF HANDWHEEL OPERATED VALVES TO ACTUATOR OPERATED VALVES and ACTUATOR MOUNTING PROCEDURES ON “L” VALVES ①

The proper procedure to follow for the conversion of handwheel valves and actuator mounting on “L” valves ① is dependent upon knowing the size and pressure class of the valve and determining the valve model. The following information will determine the valve model:

WARNING: If in doubt as to the proper procedure to follow, depressurize the valve before any disassembly is started to prevent PERSONAL INJURY and/or equipment damage.

VALVE MODEL IDENTIFICATION:

- I. 2x2, 3x2 ANSI 1500-2500 CLASS
- 3x3, 4x3 ANSI 400-1500 CLASS
- 4x4, 6x4 ANSI 150-1500 CLASS
- 6x6, 8x6 ANSI 150-600 CLASS
- 8x8, 10x8 ANSI 150-300 CLASS
- 2-1/2 API 2000-3000 WOG
- 3 & 4 API 1000-3000 WOG

The valve model for the above sizes is determined by the valve serial number lettered prefix (see Figure 10 for location of valve serial number).

1. “HA” & “HB” prefix (models “HA” & “HB”) use procedure 1B onpg. 15
2. “JA” & “JB” prefix (models “JA” & “JB”) use procedure 2B onpg. 18
3. No prefix (PREVIOUS models) use procedure 3B onpg. 22

VALVE NAMEPLATE

ORBIT VALVE				STANDARD TRIM	
LITTLE ROCK, ARK					
SIZE	3" 900 CL				
FIG	1523H RF				
SN	XX110091620001	2160	MOP		
PKG	GP6	STEM	AS		
SEAT	CR13TEF	BODY STEEL	WCC		
MFG	6D-0073	CORE TRIM	17-4		
DATE	04/01	CORE FACE	NI		
		TEMP	-20/+500 F		

Valve Serial Number with Lettered Prefix ②

ACTUATOR / VALVE or ACTUATOR NAMEPLATE

ORBIT VALVE				STANDARD TRIM	
LITTLE ROCK, ARK					
SIZE	3" 300 CL				
FIG	1223H RF				
SN	XX 110091620001	150 BAR MOP			
PKG	GP6	STEM AS			
SEAT	CR13TEF	BODY STEEL WCC			
NOTIFIED BODY	0038	CORE TRIM 17-4			
DATE	04/01	CORE FACE NI			
IMPCT TEMP		TEMP -29/+260 C			
MAX PRESS. DIFF. (BAR) FROM					
PREF. PRESS. END 19 OPPOSITE END 19					
ACTUATOR FIG. 625164					
OPERATING PRESSURE (BAR) 3.1 TO 3.4					

Actuator/Valve or Actuator Serial Number with Lettered Prefix ②

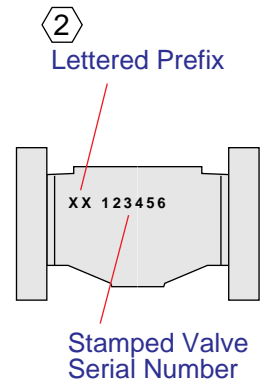

FIGURE 10
Valve Serial Number Location

NOTES:

- ① An “L” Valve is an Orbit term used to define a valve which is ready for actuator attachment. (The handwheel assembly has been removed and any adapter flanges, if required, are installed on the valve bonnet.) The “L” does not appear as a prefix or suffix to the valve serial number
- ② Some valve models do not have a lettered prefix to the serial number. These are called “PREVIOUS” models.

INSTALLATION, continued

- II. 3x3, 4x3 ANSI 2500 Class
2, 2-1/2, 3 API 5000 WOG

The valve model for all the above sizes is "HC" which appears as a prefix to the valve serial number (see Figure 10 for valve serial number location). Use the procedure 4B on pg. 26.

- III. 4x4, 6x4 ANSI 2500 Class
6x6, 8x6 ANSI 900 Class
8x8, 10x8 ANSI 400-600 Class
10x10, 12x10 ANSI 150-300 Class

The valve model for the above sizes is determined by the valve serial number lettered prefix (see Figure 10 for location of valve serial number).

1. "HC" prefix (model "HC") use procedure 5B onpg. 29
2. "HD" prefix (model "HD") use procedure 6B onpg. 32
3. No prefix (PREVIOUS model) see Figure 11 below for visual inspection to determine the bonnet configuration. The installation procedure page number is given under each illustration.

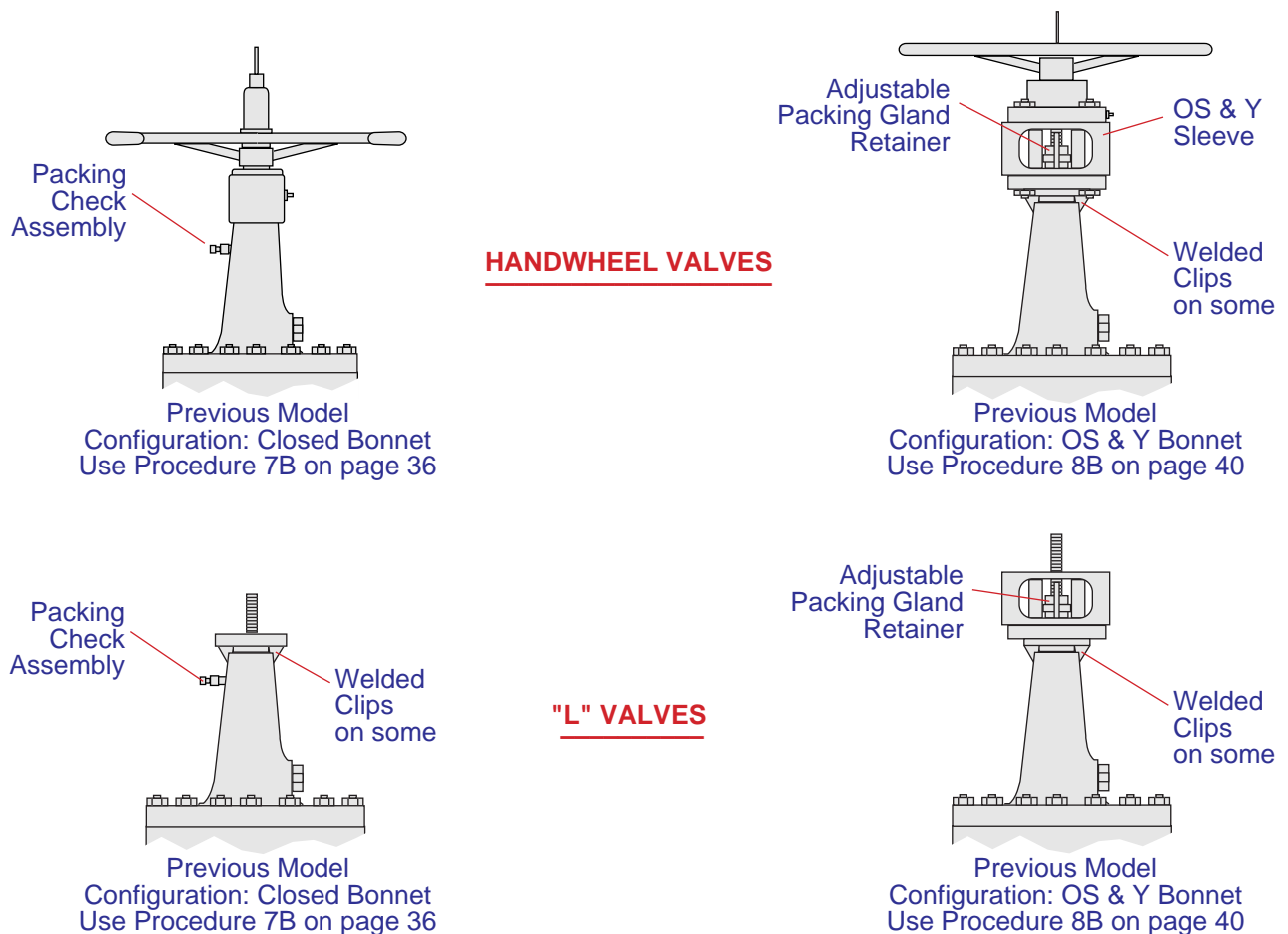

FIGURE 11
Bonnet Configuration
(Previous Models)

NOTE: Lubrication fittings and pipe plugs are not shown in these illustrations unless they are critical in identifying the valve model or configuration.

INSTALLATION, continued

- IV. 6x6, 8x6 ANSI 1500-2500 Class
- 8x8, 10x8 ANSI 900 Class
- 10x10, 12x10 ANSI 400-900 Class
- 12x12, 14x12, 16x12 ANSI 400-600 Class

The valve model for the above sizes is determined by the valve serial number lettered prefix (see figure 10 for valve serial number location).

1. "HC" prefix (model "HC") use procedure 9B on.....pg. 44
2. "HD" prefix (model "HD") use procedure 10B onpg. 48
3. No prefix (PREVIOUS model) see Figure 12 below for visual inspection to determine the bonnet configuration. The installation procedure page number is given under each illustration.

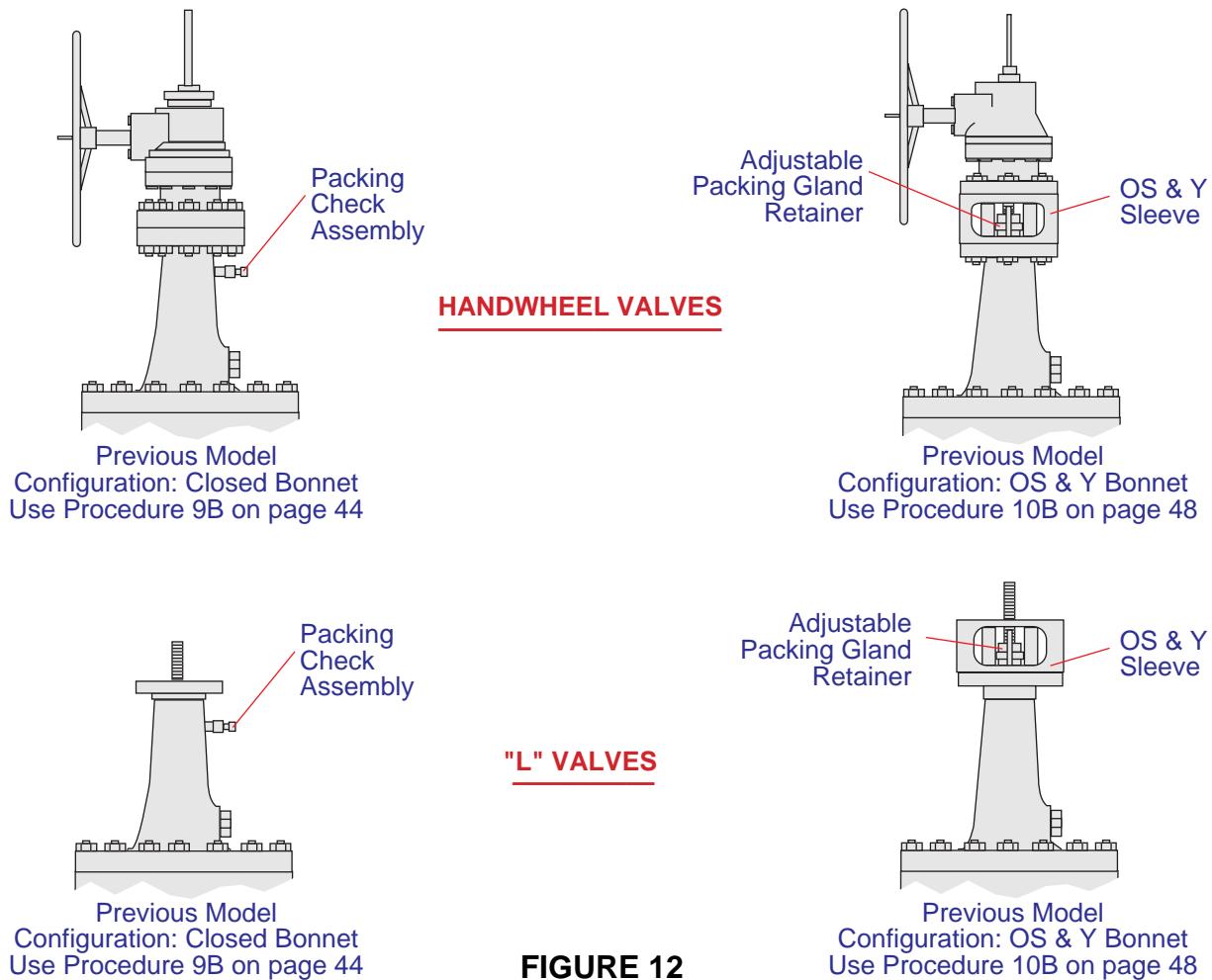

HANDWHEEL VALVES

"L" VALVES

FIGURE 12
Bonnet Configuration
(Previous Models)

NOTE: Lubrication fittings and pipe plugs are not shown in these illustrations unless they are critical in identifying the valve model or configuration.

INSTALLATION, continued

V. 12x12, 14x12, 16x12 ANSI 150-300 Class

The valve model for the above sizes is determined by the valve serial number lettered prefix (see Figure 10 for location of valve serial number).

1. "HC" prefix (model "HC") use procedure 5B on.....pg. 29
2. "HD" prefix (model "HD") use procedure 6B on.....pg. 32
3. No prefix (PREVIOUS model) see Figure 13 below for visual inspection to determine the bonnet configuration. The installation procedure page number is given under each illustration.

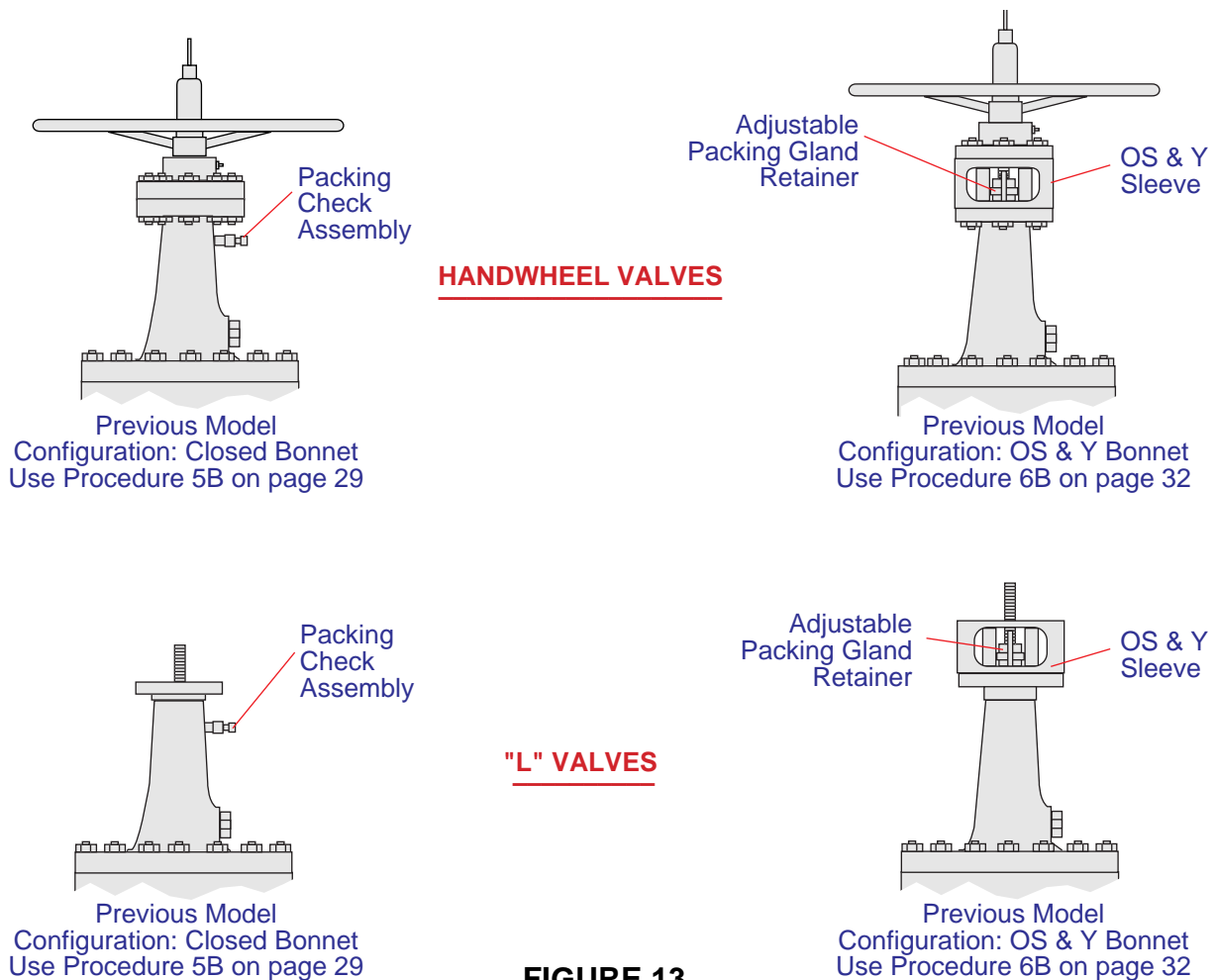

FIGURE 13
Bonnet Configuration
(Previous Models)

NOTE: Lubrication fittings and pipe plugs are not shown in these illustrations unless they are critical in identifying the valve model or configuration.

INSTALLATION, continued

CONVERSION & MOUNTING PROCEDURE - 1B

WARNING: This mounting and conversion procedure is for valve models “HA” and “HB”, size & pressures:

2x2, 3x2 ANSI 1500-2500 CLASS
3x3, 4x3 ANSI 400-1500 CLASS
4x4, 6x4 ANSI 150-1500 CLASS
6x6, 8x6 ANSI 150-600 CLASS

8x8, 10x8 ANSI 150-300 CLASS
2-1/2 API 2000-3000 WOG
3 & 4 API 1000-3000 WOG

BEFORE converting or mounting, be certain this is the correct procedure. Failure to do this could result in PERSONAL INJURY and/or equipment damage. See pages 11-14 for identifying other procedures.

Refer to Figure 14 for steps 1 through 6.

(NOTE: Steps 1 through 6 are omitted if the handwheel assembly has been removed.)

1. Fully open the valve with the handwheel.
2. Remove stem protector, washer, and V.P.I. rod with nut.
3. Remove handwheel.
4. Remove nuts & bolts holding the drive nut retainer.
5. Remove drive nut retainer, drive nut (left hand threads), bearings and races.
6. The valve is now an “L” valve, as shown and is ready for actuator attachment.

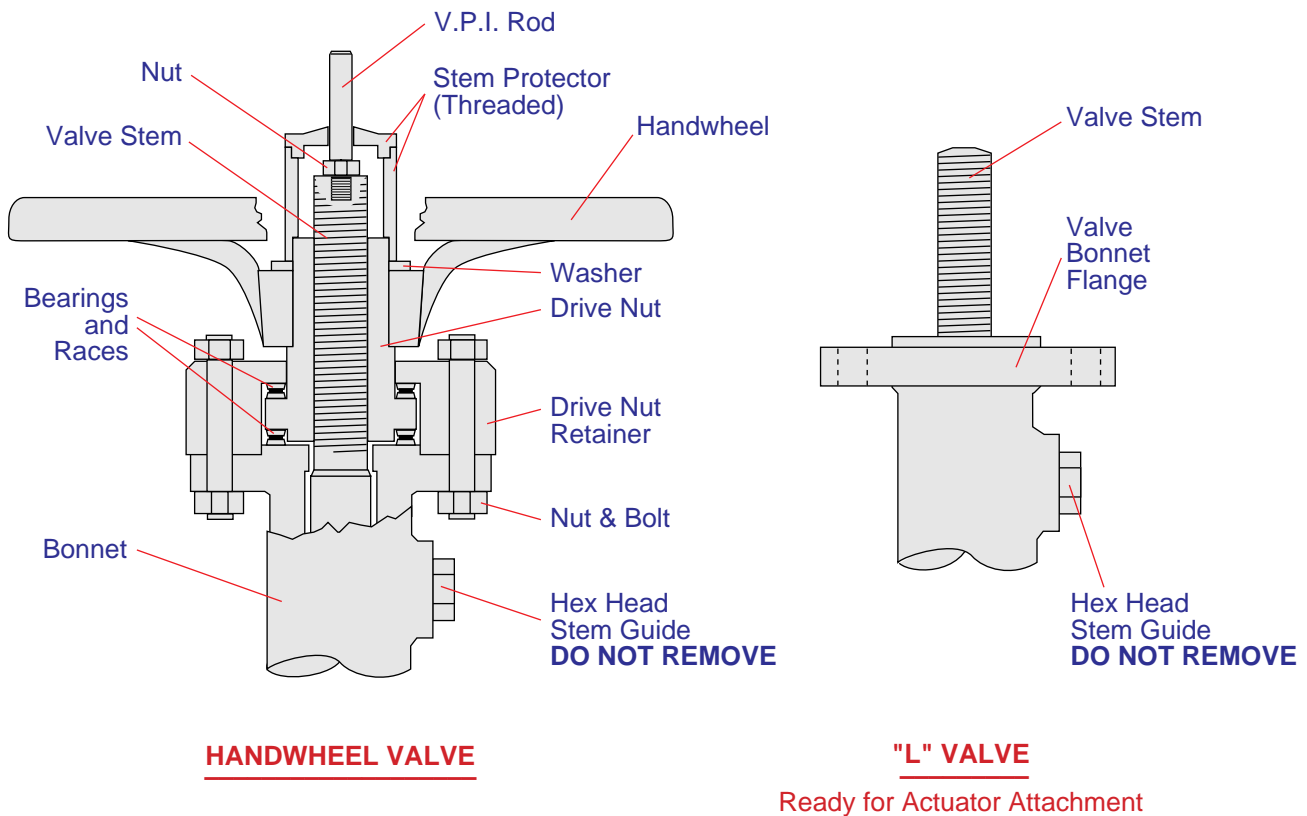

FIGURE 14
Handwheel to “L” Valve (Procedure - 1B)

INSTALLATION, continued

Refer to Figure 15 for steps 7 through 14. (Lubricate as noted in figure.)

7. Install and orientate the actuator plate to the valve bonnet flange using four (4) studs & nuts. Tighten to 60 ft-lbs (81 Nm) using a criss-cross pattern. See view A-A.
8. Thread the actuator unit onto the valve stem (left hand threads) until the distance between the actuator flange and the actuator adapter plate is equal to the assembly dimension for the appropriate actuator. (NOTE: When setting the assembly dimension, the valve is in the full-open position and the actuator is in the full-closed position.)
9. Orientate the actuator to the valve by noting the relationship of the lower gas inlet and the valve bore centerline.
10. Lower the actuator until the actuator flange and adapter plate contact. (NOTE: If they do not contact due to actuator spring compression, apply gas pressure to the lower gas inlet, starting at 20 psig (1.4 bars) and increasing by 5 psig (0.35 bars) steps until they contact. (Do not exceed rated pressure stamped on nameplate of the actuator.)

CAUTION:

Be sure hands and tools are not between the actuator flange and adapter plate, as the actuator will move quickly to make contact with the adapter plate.

11. Install the position indicator plate bracket, bolts, lock washers & nuts, and tighten to 120 ft lbs (163 Nm) using a criss-cross pattern.
12. Install any accessories not already installed to the actuator unit or valve.
13. Lubricate the actuator and check/fill the gas-over-oil tank as described in the "MAINTENANCE" section on page 91 . Adjust the spring compression as detailed in the "SPRING COMPRESSION ADJUSTMENT" section on page 54 . Install and adjust the visual position indicator plates as detailed in the "INDICATOR PLATES (INSTALLATION & ADJUSTMENT)" section on page 52.
14. The actuator mounting is complete.

INSTALLATION, continued

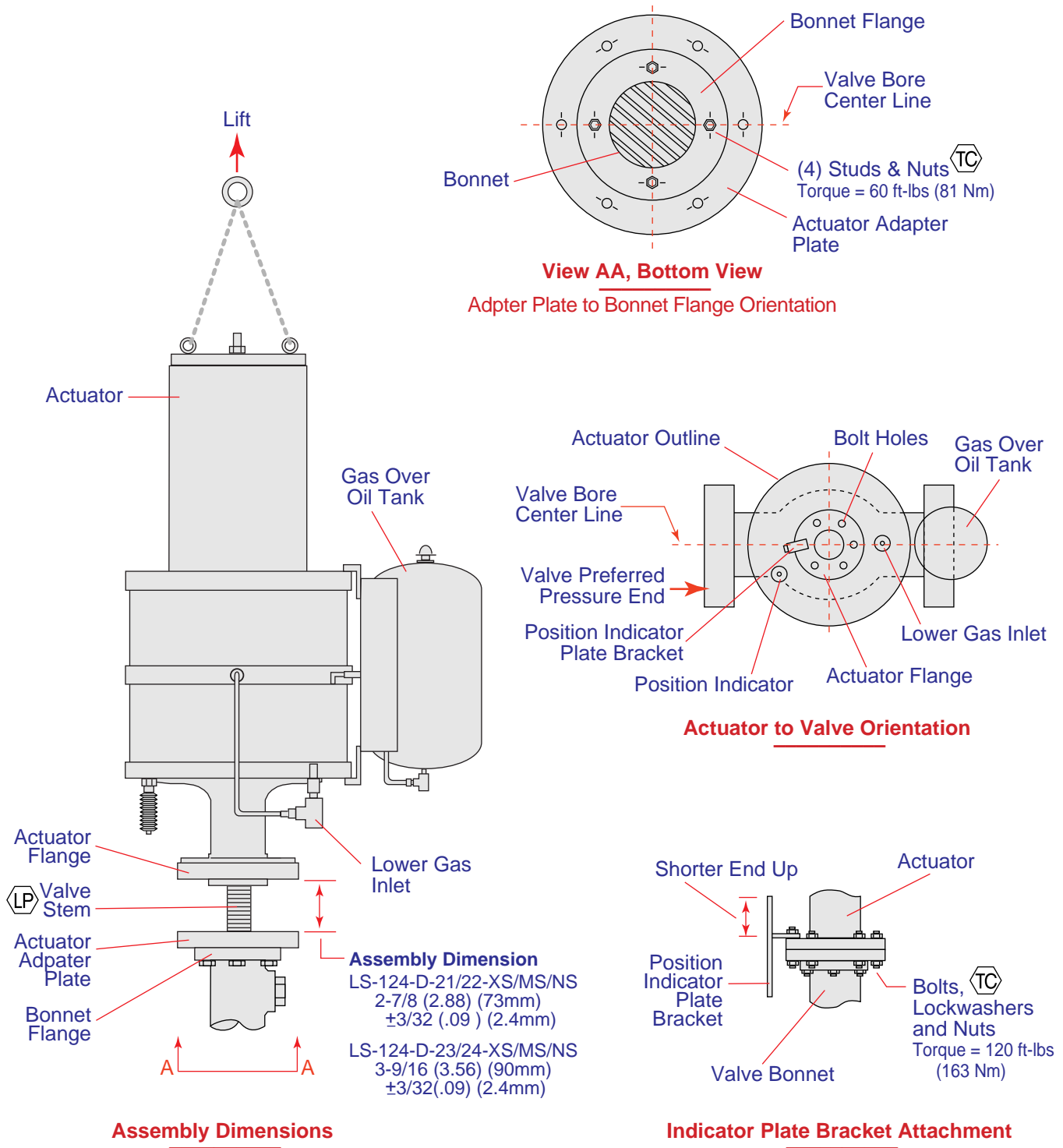

FIGURE 15
 Actuator Mounting (Procedure - 1B)

NOTES:

- TC Apply FEL-PRO "C-102" anti-seize lubricant
- LP Lubricate threads with Lubriplate "930-AA" prior to assembly

INSTALLATION, continued

CONVERSION & MOUNTING PROCEDURE - 2B

WARNING: This mounting and conversion procedure is for valve models "JA" and "JB", size & pressures:

2x2, 3x2 ANSI 1500-2500 CLASS
 3x3, 4x3 ANSI 400-1500 CLASS
 4x4, 6x4 ANSI 150-1500 CLASS
 6x6, 8x6 ANSI 150-600 CLASS

8x8, 10x8 ANSI 150-300 CLASS
 2-1/2 API 2000-3000 WOG
 3 & 4 API 1000-3000 WOG

BEFORE converting or mounting, be certain this is the correct procedure. Failure to do this could result in PERSONAL INJURY and/or equipment damage. See pages 11-14 for identifying other procedures.

Refer to Figure 16 for steps 1 through 8.

(NOTE: Steps 1 through 8 are omitted if the handwheel assembly has been removed and the adapter assembly has previously been mounted.)

1. Fully open valve with handwheel.
2. Remove stem protector, washer, and VPI rod with nut.
3. Remove handwheel.
4. Loosen set screw and remove drive nut retainer.
5. Remove drive nut (left hand threads), bearings and races.
6. Clean threads on bonnet. Do not lubricate.
7. Screw adapter flange (2-3/4-12 UNC thread) onto bonnet until the preliminary assembly dimension is achieved with two bolt holes in the adapter flange aligned with the valve bore centerline. (NOTE: Do not install set screws in the adapter flange until step 12.)
8. Valve is now a preliminary "L" valve, as shown, and is ready for the actuator adapter plate attachment.

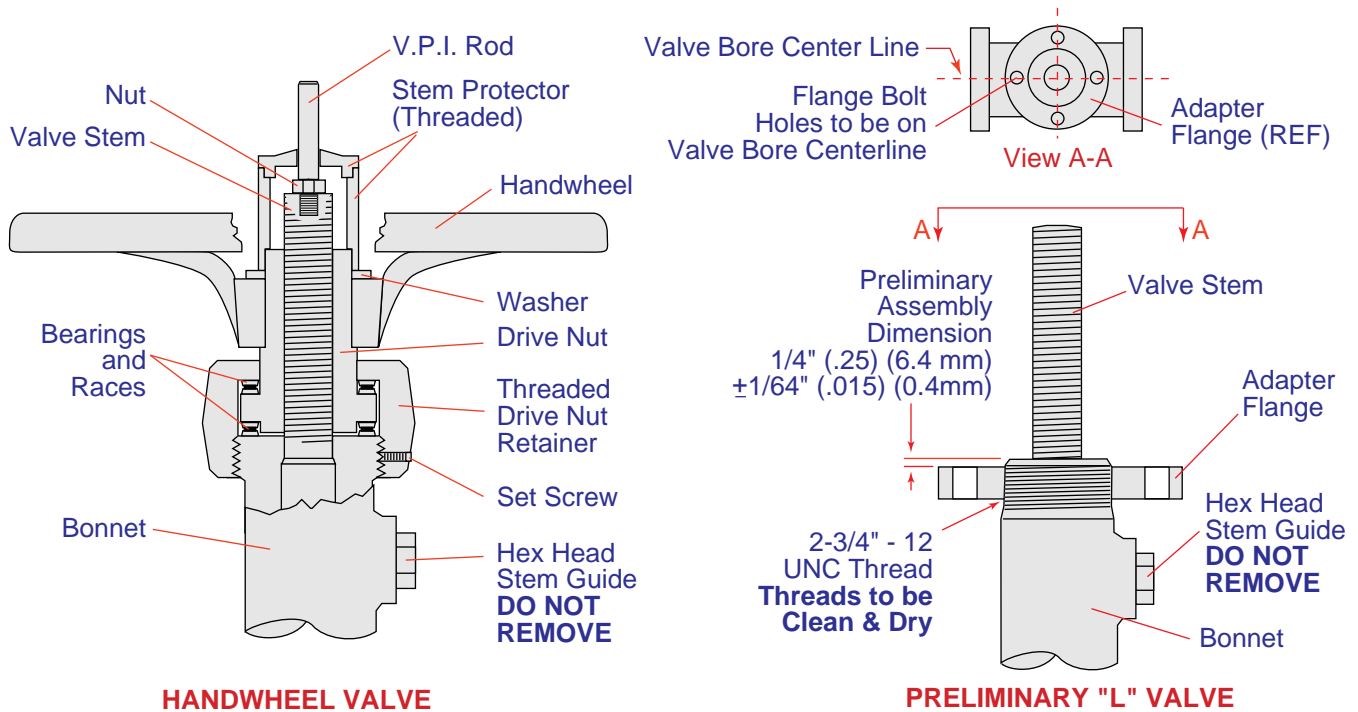

FIGURE 16

Handwheel to "L" Valve (Procedure - 2B)

INSTALLATION, continued

Refer to Figure 17 for steps 9 through 13. (NOTE: Steps 10,12 and 13 are omitted if the bonnet adapter flange has previously been welded to the valve bonnet.)

9. Install and orientate the actuator adapter plate to the bonnet adapter flange as shown in view A-A.
10. Check the assembly clearance, 1/32 (.03) (0.8 mm), between the actuator adapter plate and the bonnet adapter flange. Adjust if necessary, by rotating the bonnet adapter flange in 90° increments. Be sure orientation of the plate and adapter is still correct.
11. Install the four (4) studs & nuts. Tighten to 60 ft-lbs (81 Nm) using a criss-cross pattern.
12. Place a cup-point punch in each set screw hole on the bonnet adapter flange, strike sharply with a hammer, install the two (2) set screws, and tighten securely. (NOTE: Factory mounted adapter flanges do not have set screws.)

NOTE: Installation of an adapter flange is intended to be permanent. If conversion back to handwheel operation is later desired, “bolt on” type drive nut retainers can be obtained from Orbit.

13. Weld the bonnet adapter flange to the valve bonnet with 1/4 x 3/4 x 3/4 inch (6 x 20 x 20 mm) welding bridge as shown. (Recommended, but not required.)

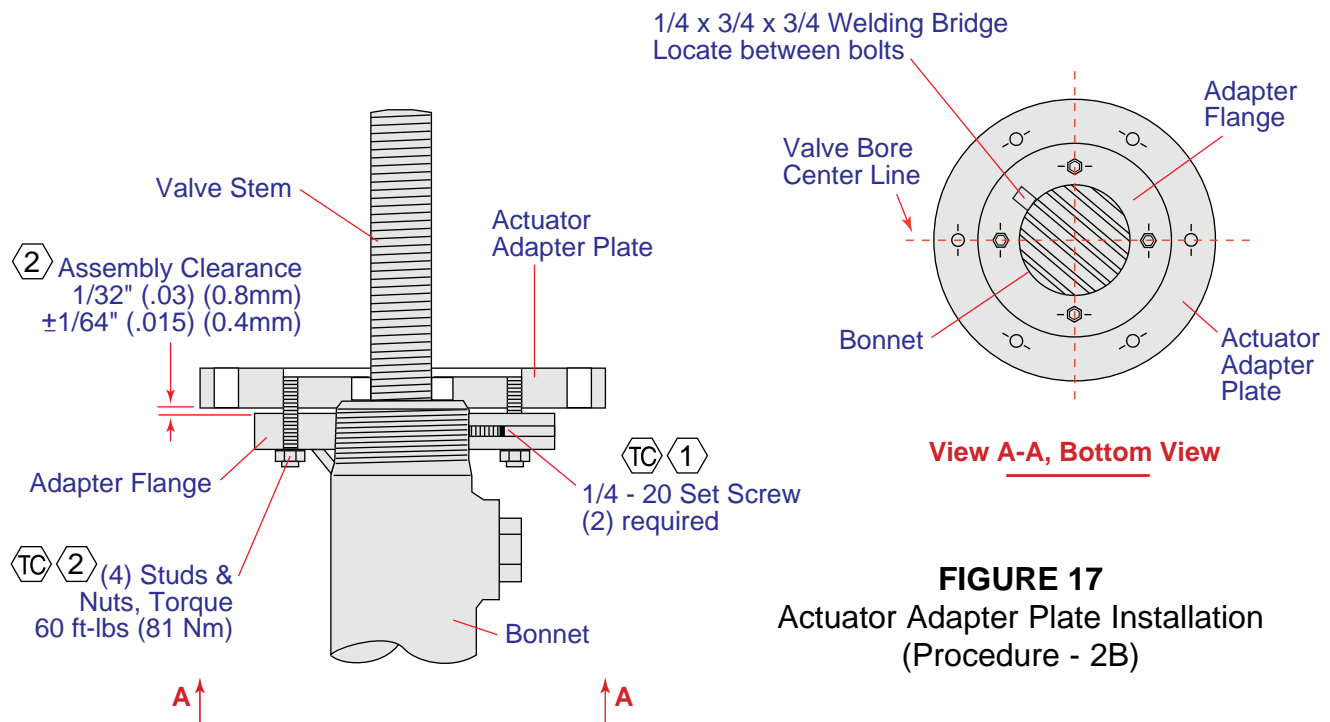

FIGURE 17
Actuator Adapter Plate Installation
(Procedure - 2B)

NOTES:

- ① Included with field mounted adapter flanges only.
- ② Set assembly clearance before installing the four (4) studs & nuts, tightening the two (2) set screws, or welding bridge to bonnet and flange.
- TC Apply FEL-PRO “C-102” anti-seize lubricant

INSTALLATION, continued

Refer to Figure 18 for steps 14 through 20. (Lubricate as noted in figure.)

14. Thread the actuator unit onto the valve stem (left hand threads) until the distance between the actuator flange and the actuator adapter plate is equal to the assembly dimension for the appropriate actuator.
(NOTE: When setting the assembly dimension, the valve is in the full-open position and the actuator is in the full-closed position.)
15. Orientate the actuator to the valve by noting the relationship of the lower gas inlet and the valve bore centerline.
16. Lower the actuator until the actuator flange and adapter plate contact.
(NOTE: If they do not contact due to actuator spring compression, apply gas pressure to the lower gas inlet starting at 20 psig (1.4 bars) and increasing by 5 psig (0.35 bars) steps until they contact.) (Do not exceed rated pressure stamped on nameplate for actuator.)

CAUTION:

Be sure hands and tools are not between the actuator flange and the adapter plate, as the actuator will move quickly to make contact with the adapter plate.

17. Install the position indicator plate bracket, bolts, lockwashers & nuts, and tighten to 120 ft-lbs (163 Nm) using a criss-cross pattern.
18. Install any accessories not already installed to the actuator unit or valve.
19. Lubricate the actuator and check/fill the gas-over-oil tank as described in the "MAINTENANCE" section on page 91. Adjust the spring compression as detailed in the "SPRING COMPRESSION ADJUSTMENT" section on page 54. Install and adjust the visual position indicator plates as detailed in the "INDICATOR PLATES (INSTALLATION & ADJUSTMENT)" section on page 52.
20. The actuator mounting is complete.

INSTALLATION, continued

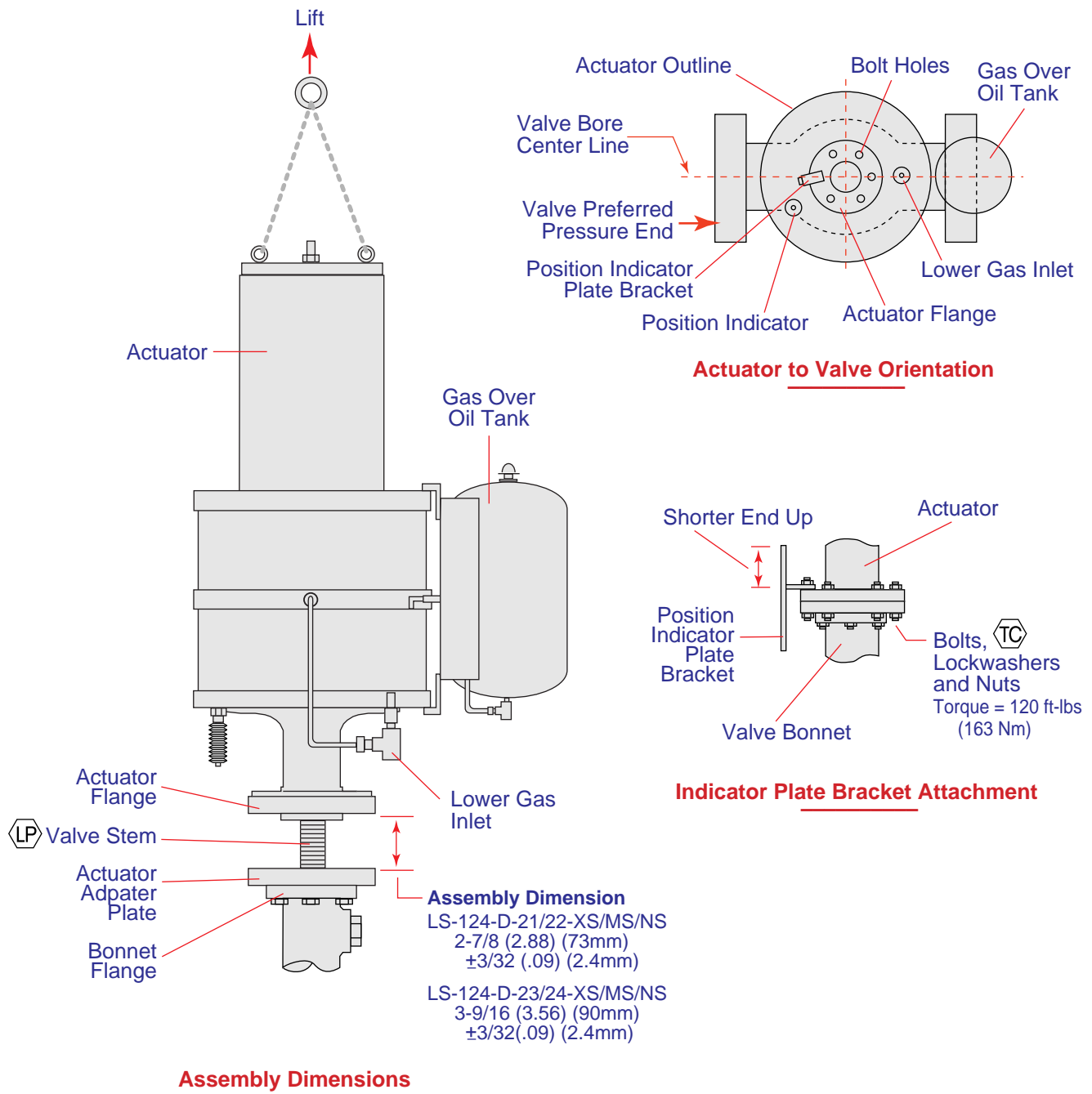

FIGURE 18
 Actuator Mounting (Procedure - 2B)

NOTES:

- Ⓣ Apply FEL-PRO “C-102” anti-seize lubricant
- Ⓛ Lubricate threads with Lubriplate “930-AA” prior to assembly

INSTALLATION, continued

CONVERSION & MOUNTING PROCEDURE - 3B

WARNING: This mounting and conversion procedure is for “PREVIOUS” valve models, size & pressures:

2x2, 3x2 ANSI 1500-2500 CLASS
3x3, 4x3 ANSI 150-1500 CLASS
4x4, 6x4 ANSI 150-1500 CLASS
6x6, 8x6 ANSI 150-600 CLASS

8x8, 10x8 ANSI 150-300 CLASS
2-1/2 API 2000-3000 WOG
3 & 4 API 1000-3000 WOG

BEFORE converting or mounting, be certain this is the correct procedure and verify that all valve line pressure has been bled. Failure to do this could result in PERSONAL INJURY and/or equipment damage. See pages 11-14 for identifying other procedures.

Refer to Figure 19 for steps 1 through 12.

(NOTE: Steps 1 through 12 are omitted if the handwheel assembly has been removed and the adapter flange has been installed.)

1. Open the valve with the handwheel and then partially close it. (3/4 to 1 turn of the handwheel).
2. Remove the stem protector, washer, and VPI rod with nut.
3. Remove the handwheel.
4. Remove the set screw, welded clip (if attached) with a hammer and chisel, and threaded drive nut retainer. (NOTE: Do not remove the stem guide.)
5. Remove the drive nut (left hand threads), bearings, and races.
6. Clean the bonnet threads.
7. Thread the adapter flange onto the bonnet to the appropriate assembly dimension.
8. Align two of the bolt holes with the valve bore centerline. See View AA.
9. Screw lock nut into adapter flange and tighten securely.

WARNING: Lock nut is mandatory to lock the adapter flange in place, provide the open-position stem stop during operation, and assure stem retention in the event the actuator is subsequently removed without depressuring the valve. INJURY CAN RESULT from failure to provide this stem retention.

10. Weld two small steel tabs (approx. 3/16 x 3/4 x 3/4) to the adapter flange and valve bonnet and, then, one steel clip (approximately 3/16 x 3/4 x 2-1/2) over the stem guide as shown.
11. Install the lube fitting in the adapter flange if it is an OS&Y valve bonnet configuration. (NOTE: Standard closed bonnet configurations do not have, nor need, the adapter flange drilled for a lube fitting.)
12. Valve is now an “L” valve, as shown, and is ready for actuator attachment.

INSTALLATION, continued

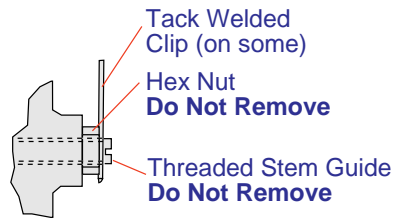

T7 Trim Only
applies to all valves
shown on this page

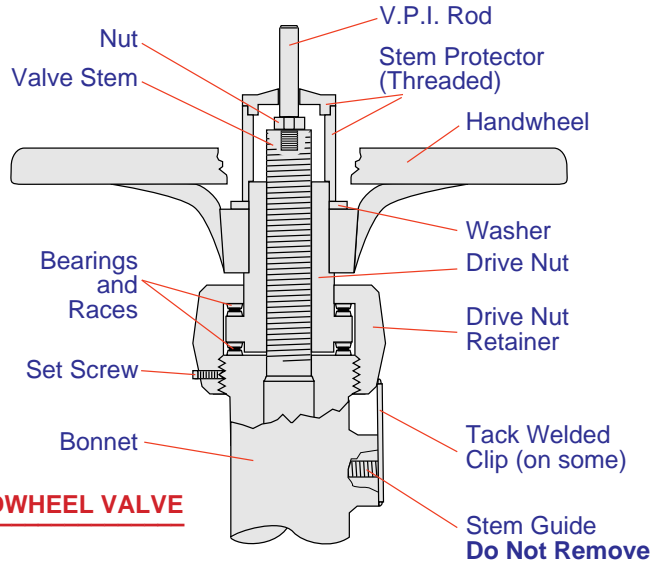

HANDWHEEL VALVE

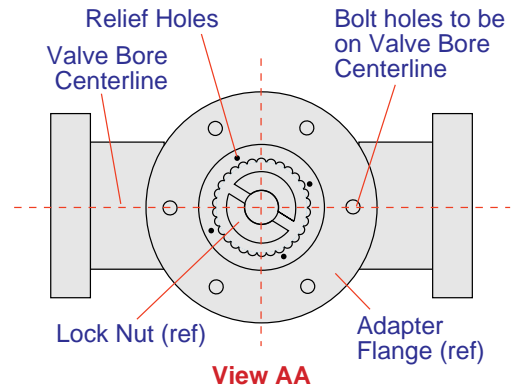
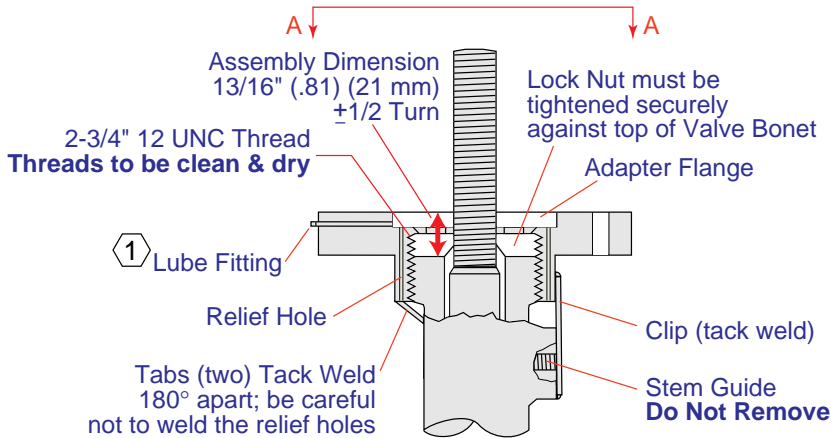

"L" VALVE (2-3/4-12 Threaded Bonnet) Ready for actuator attachment

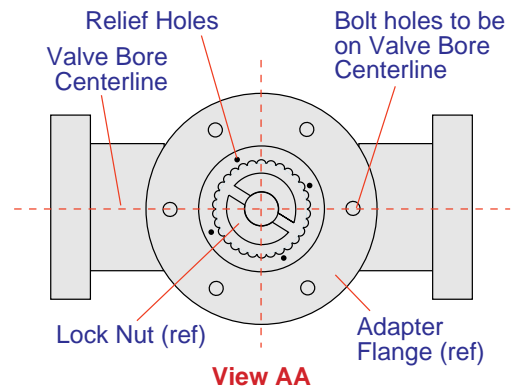
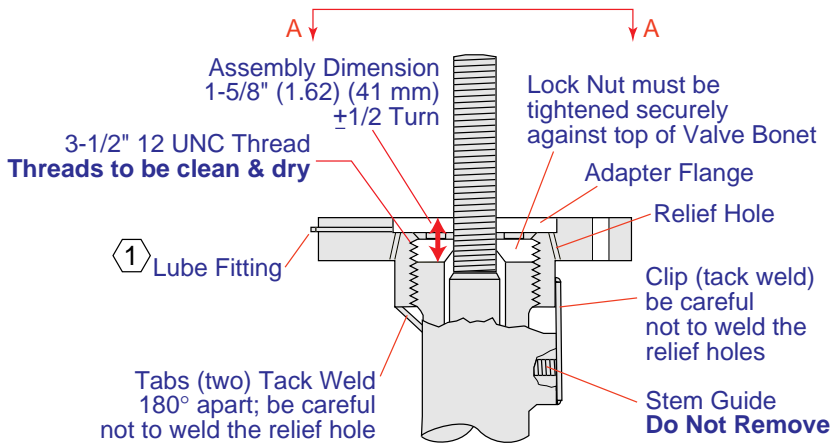

"L" VALVE (3-1/2-12 Threaded Bonnet) Ready for actuator attachment

FIGURE 19

Handwheel to "L" Valve (Procedure - 3B)

NOTE: ① Lube fitting used on OS&Y bonnet configuration only. Closed bonnet configuration does not have, nor need, the adapter flange drilled for the lube fitting.

INSTALLATION, continued

Refer to Figure 20 for steps 13 through 19. (Lubricate as noted in figure.)

13. Thread the actuator unit onto the valve stem (left hand threads) until the distance between the actuator flange and the adapter flange is equal to the assembly dimension for the appropriate actuator. (NOTE: When setting the assembly dimension, the valve is in the full-open position and the actuator is in the full-closed position.) (NOTE: Actuator models LS-124-D-21 & D-22 include an actuator adapter plate which is not used on this application. Other applications use this plate between the actuator flange and the valve adapter flange.)
14. Orientate the actuator to the valve by noting the position of the lower gas inlet and the valve bore centerline.
15. Lower the actuator until the actuator flange and adapter flange contact. (NOTE: If they do not contact due to actuator spring compression, apply gas pressure to the lower gas inlet, starting at 20 psig (1.4 bars) and increasing by 5 psig (0.35 bars) steps until they contact.) (Do not exceed rated pressure stamped on actuator nameplate.)

CAUTION:

Be sure hands and tools are not between the actuator flange and valve adapter flange, as the actuator will move quickly to make contact with the valve adapter flange.

16. Install position indicator plate bracket, bolts, lock washers & nuts, and tighten to 120 ft-lbs (163 Nm) using a criss-cross pattern.
17. Install any accessories not already installed to the actuator unit or valve.
18. Lubricate the actuator and check/fill the gas-over-oil tank as described in the "MAINTENANCE" section on page 91. Adjust the spring compression as detailed in the "SPRING COMPRESSION ADJUSTMENT" section on page 54. Install and adjust the visual position indicator plates as detailed in the "INDICATOR PLATES (INSTALLATION & ADJUSTMENT)" section on page 52.
19. The actuator mounting is complete.

INSTALLATION, continued

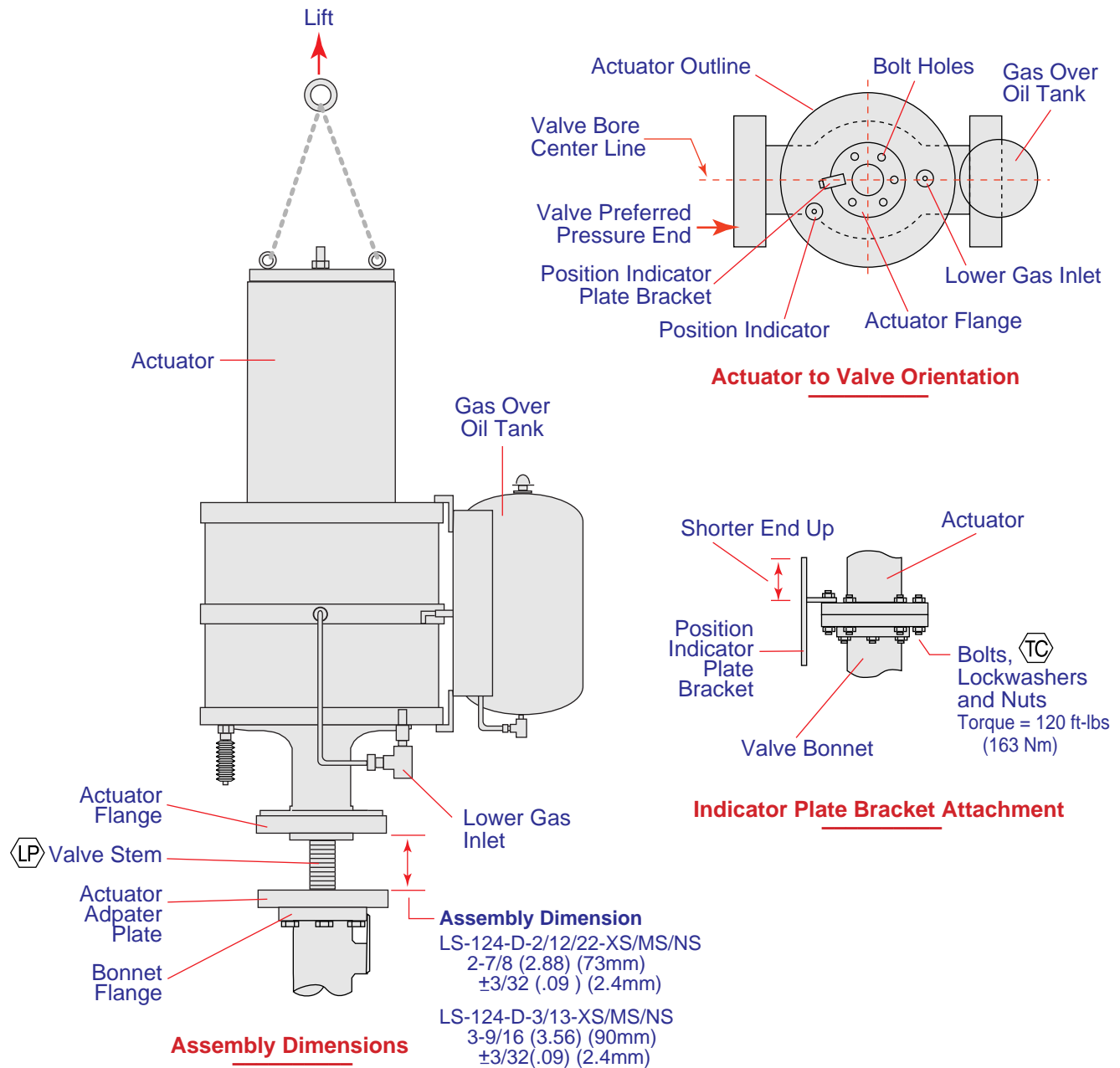

FIGURE 20
Actuator Mounting (Procedure - 3B)

NOTES:

- Ⓣ Apply FEL-PRO "C-102" anti-seize lubricant
- Ⓛ Lubricate threads with Lubriplate "930-AA" prior to assembly

INSTALLATION, continued

CONVERSION & MOUNTING PROCEDURE - 4B

WARNING: This mounting and conversion procedure is for valve model "HC" size and pressure:

3 x 3, 4 x 3 ANSI 2500 CLASS
2, 2-1/2, 3 ANSI 5000 W.O.G.

BEFORE converting or mounting, be certain this is the correct procedure. Failure to do this could result in PERSONAL INJURY and/or equipment damage. See pages 11-13 for identifying other procedures.

Refer to Figure 21 for steps 1 through 6.

(NOTE: Steps 1 through 6 are omitted if the handwheel assembly has been removed.)

1. Fully open the valve with the handwheel.
2. Remove stem protector, washer, and V.P.I. rod with nut.
3. Remove handwheel.
4. Remove nuts & bolts holding the drive nut retainer.
5. Remove drive nut retainer, drive nut (left hand threads), bearings and races.
6. Valve is now an "L" valve, as shown, and is ready for actuator attachment.

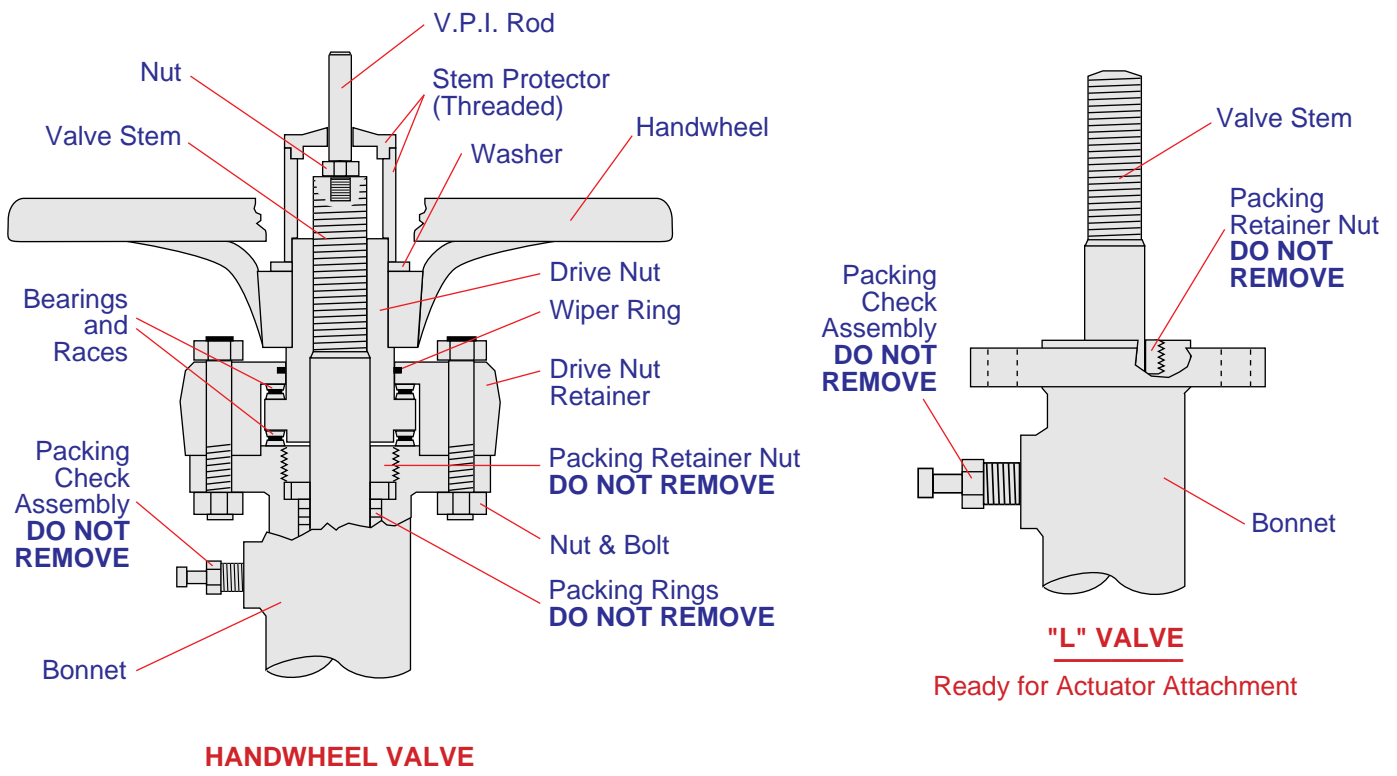

FIGURE 21
Handwheel to "L" Valve (Procedure - 4B)

INSTALLATION, continued

Refer to Figure 22 for steps 7 through 14. (Lubricate as noted in figure.)

7. Install and orientate the actuator adapter plate to the valve bonnet flange using four (4) studs & nuts. Tighten to 60 ft-lbs (81 Nm) using a criss-cross pattern. See view A-A.
8. Thread the actuator unit onto the valve stem (left hand threads) until the distance between the actuator flange and the actuator adapter plate is equal to the assembly dimension for the appropriate actuator.
(NOTE: When setting the assembly dimension, the valve is in the full open position and the actuator is in the full-closed position.)
9. Orientate the actuator to the valve by noting the relationship of the lower gas inlet to the valve bore centerline.
10. Lower the actuator until the actuator flange and adapter plate contact.
(NOTE: If they do not contact due to actuator spring compression, apply gas pressure to the lower gas inlet starting at 20 psig (1.4 bars) and increasing by steps of 5 psig (0.35 bars) until they contact.) (Do not exceed rated pressure stamped on nameplate for actuator.)

CAUTION:

Be sure hands and tools are not between the actuator flange and the adapter plate, as the actuator will move quickly to make contact with the adapter plate.

11. Install the position indicator plate bracket, bolts, lockwashers & nuts, and tighten to 120 ft-lbs (163 Nm) using a criss-cross pattern.
12. Install any accessories, not already installed, to the actuator unit or valve.
13. Lubricate the actuator and check/fill the gas-over-oil tank as described in the "MAINTENANCE" section on page 91. Adjust the spring compression as detailed in the "SPRING COMPRESSION ADJUSTMENT" section on page 54. Install and adjust the visual position indicator plates as detailed in the "INDICATOR PLATES (INSTALLATION & ADJUSTMENT)" section on page 52 .
14. The actuator mounting is complete.

INSTALLATION, continued

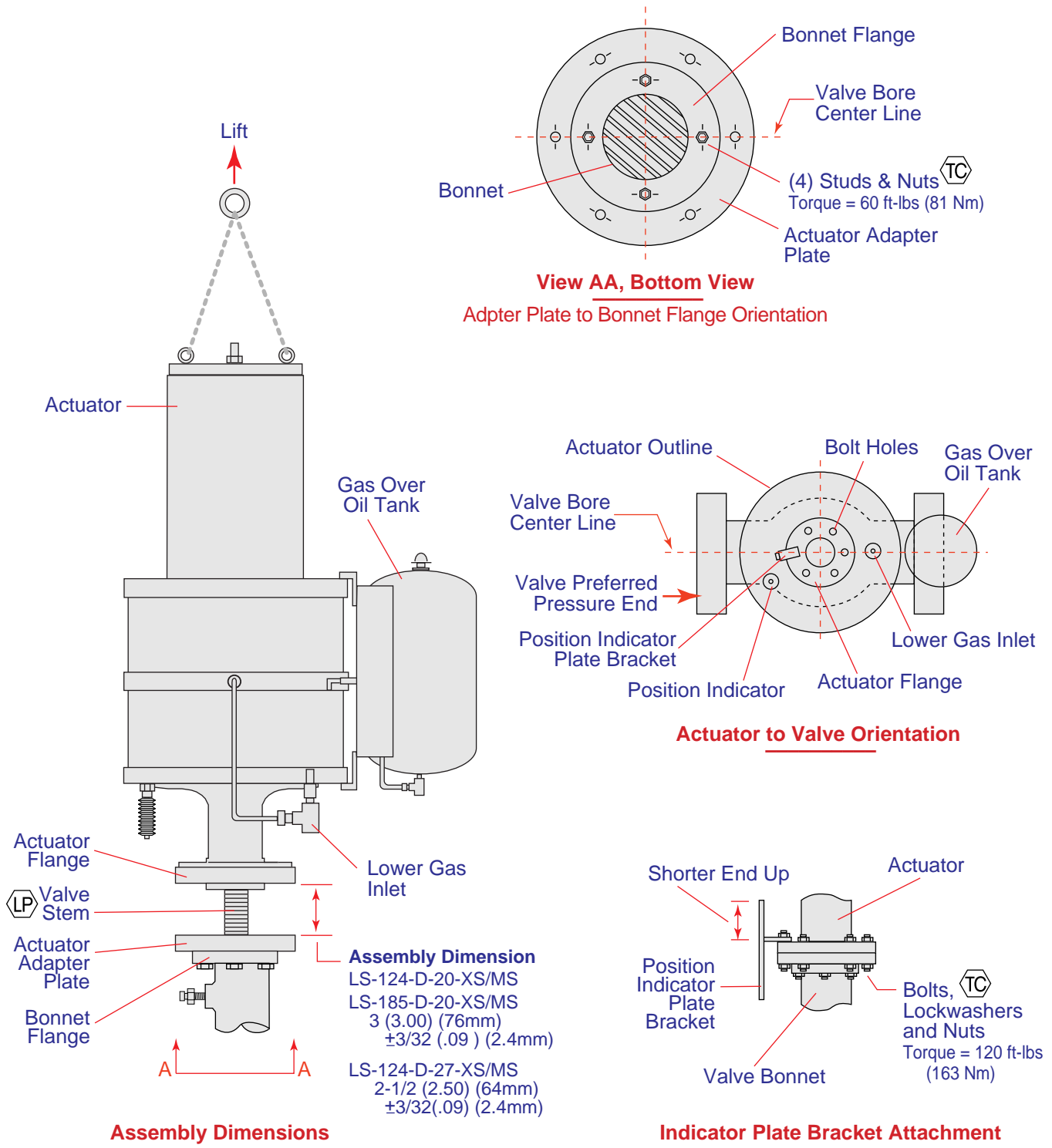

FIGURE 22
 Actuator Mounting (Procedure - 4B)

NOTES:

- Apply FEL-PRO "C-102" anti-seize lubricant
- Lubricate threads with Lubriplate "930-AA" prior to assembly

INSTALLATION, continued

CONVERSION & MOUNTING PROCEDURE - 5B

WARNING: This mounting & conversion procedure is for valve model "HC" size & pressures:

4x4, 6x4 ANSI 2500 CLASS
6x6, 8x6 ANSI 900 CLASS
8x8, 10x8 ANSI 400-600 CLASS

10x10, 12x10 ANSI 150-300 CLASS
12x12, 14x12, 16x12 ANSI 150-300 CLASS

This procedure is also for "PREVIOUS" valve models with the closed bonnet configuration. Size & pressures:

12x12, 14x12, 16x12 ANSI 150-300 CLASS

BEFORE converting or mounting, be certain this is the correct procedure. Failure to do this could result in PERSONAL INJURY and/or equipment damage. See pages 11-14 for identifying other procedures.

Refer to figure 23 for steps 1 through 5.

(NOTE: Steps 1 through 5 are omitted if the handwheel assembly has been removed.)

1. Remove watertight connector and stem protector.
2. Remove the VPI rod with the hex jam nut.
3. Remove the bolts, washers, and nuts
4. Turn the handwheel clockwise  until the entire handwheel assembly comes loose from the valve stem. (Drive nut retainer, drive nut, bearings, races and handwheel are removed as a unit.)
5. Valve is now an "L" valve, as shown, and is ready for actuator attachment.

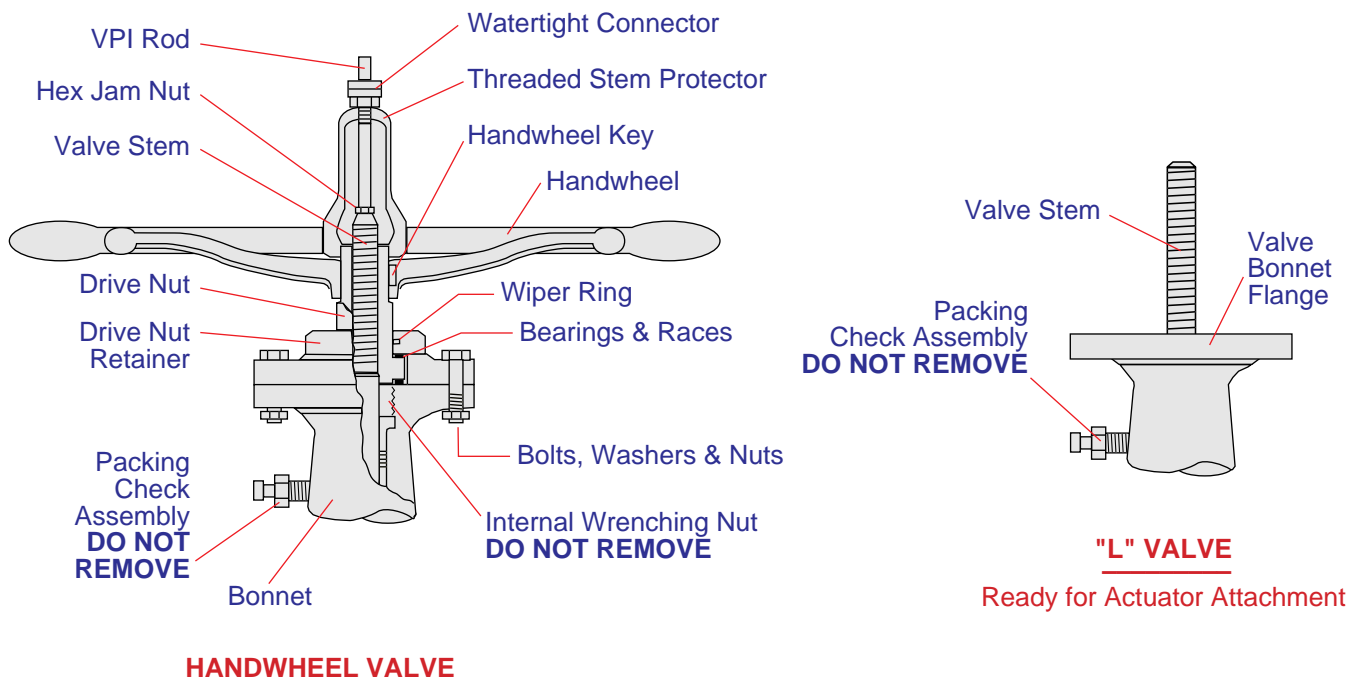

FIGURE 23

Handwheel to "L" Valve (Procedure - 5B)

INSTALLATION, continued

Refer to Figure 24 for steps 6 through 12. (Lubricate as noted in figure.)

6. Thread the actuator unit onto the valve stem (left hand threads) until the distance between the actuator flange and the valve bonnet flange is equal to the assembly dimension for the appropriate actuator. (NOTE: When setting the assembly dimension, the valve is in the full-open position and the actuator is in the full-closed position.)
7. Orientate the actuator to the valve by noting the relationship of the lower gas inlet and the valve bore centerline.
8. Lower the actuator until the actuator flange and valve bonnet flange contact. (NOTE: If they do not contact due to actuator spring compression, apply gas pressure to the lower gas inlet starting at 20 psig (1.4 bars) and increasing by steps of 5 psig (0.35 bars) until they contact.) (Do not exceed rated pressure stamped on nameplate for actuator.)

CAUTION:

Be sure hands and tools are not between the actuator flange and the adapter plate, as the actuator will move quickly to make contact with the adapter plate.

9. Install the position indicator plate bracket, bolts, lock washers & nuts, and tighten to the proper torque using a criss-cross pattern. (Six (6) hole pattern, torque to 120 ft-lbs (163 Nm), eight (8) hole pattern, torque to 200 ft-lbs (271 Nm)).
10. Install any accessories, not already installed, to the actuator unit or valve.
11. Lubricate the actuator and check/fill the gas-over-oil tank as described in the "MAINTENANCE" section on page 91 . Adjust the spring compression as detailed in the "SPRING COMPRESSION ADJUSTMENT" section on page 54. Install and adjust the visual position indicator plates as detailed in the "INDICATOR PLATES (INSTALLATION & ADJUSTMENT)" section on page 52.
12. The actuator mounting is complete.

INSTALLATION, continued

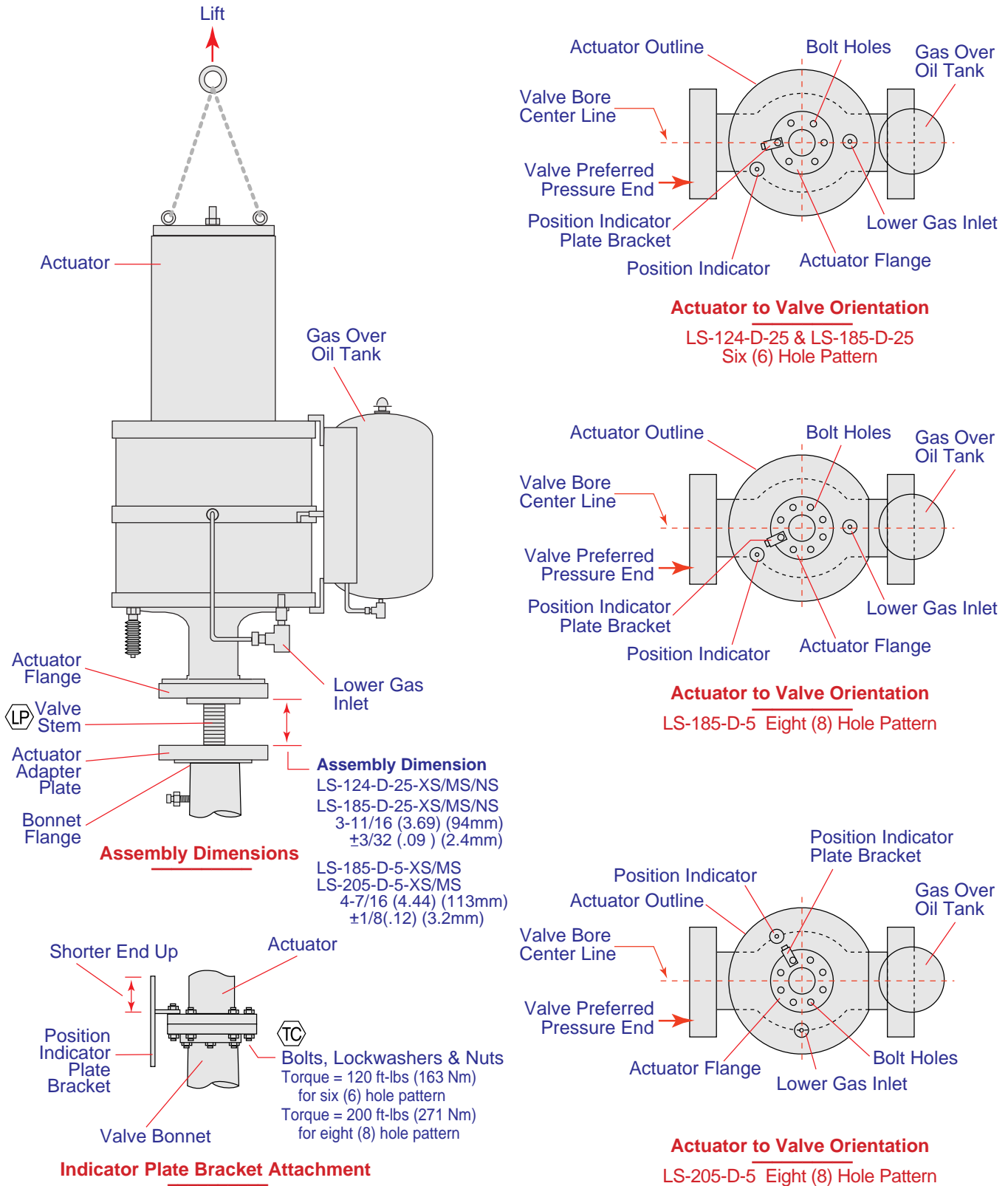

FIGURE 24
 Actuator Mounting (Procedure - 5B)

NOTES:

- ⓉC Apply FEL-PRO "C-102" anti-seize lubricant
- ⓁP Lubricate threads with Lubriplate "930-AA" prior to assembly

INSTALLATION, continued

CONVERSION & MOUNTING PROCEDURE - 6B

WARNING: This mounting & conversion procedure is for valve model “HD” size & pressures:

6x6, 8x6 ANSI 900 Class	10x10, 12x10, ANSI 150-300 Class
8x8, 10x8 ANSI 400-600 Class	12x12, 14x12, 16x12 ANSI 150-300 Class

This procedure is also for “PREVIOUS” valve models with the OS & Y bonnet configuration. Size & pressures:

12x12, 14x12, 16x12 ANSI 150-300 CLASS

BEFORE converting or mounting, be certain this is the correct procedure. Failure to do this could result in PERSONAL INJURY and/or equipment damage. See pages 11-14 for identifying other procedures.

Refer to Figure 25 for steps 1 through 5.

(NOTE: Steps 1 through 5 are omitted if the handwheel assembly has been removed.)

1. Fully open valve with handwheel.
2. Remove the studs, lock-washers & nuts that hold the bearing case assembly to the sleeve.
3. Remove the entire handwheel and bearing case assembly as one unit by unscrewing it from the valve stem. (Left hand valve stem threads.) (NOTE: When it comes loose from the valve stem, lift it straight off the VPI rod.)
4. Remove the VPI rod with the hex jam nut.
5. The valve is now an “L” valve, as shown, and is ready for actuator attachment.

INSTALLATION, continued

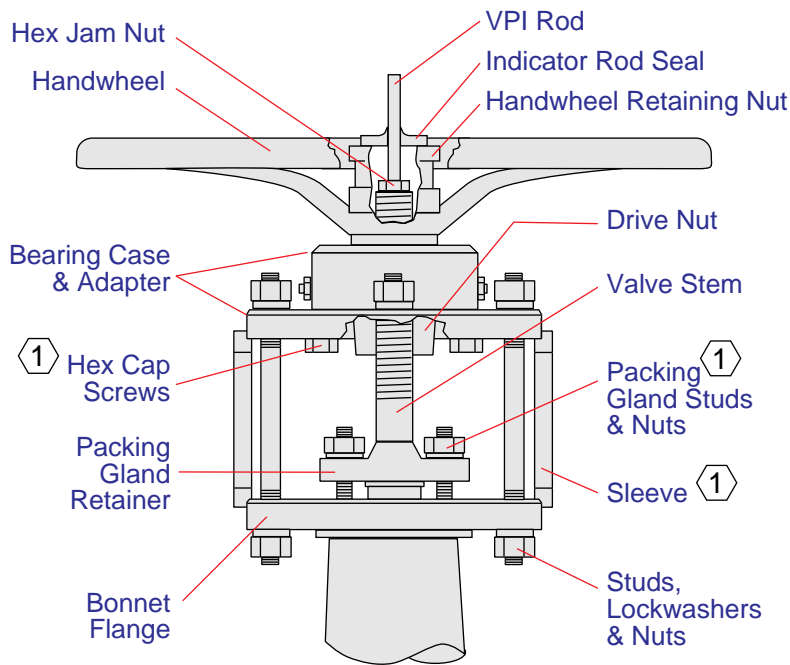

HANDWHEEL VALVE

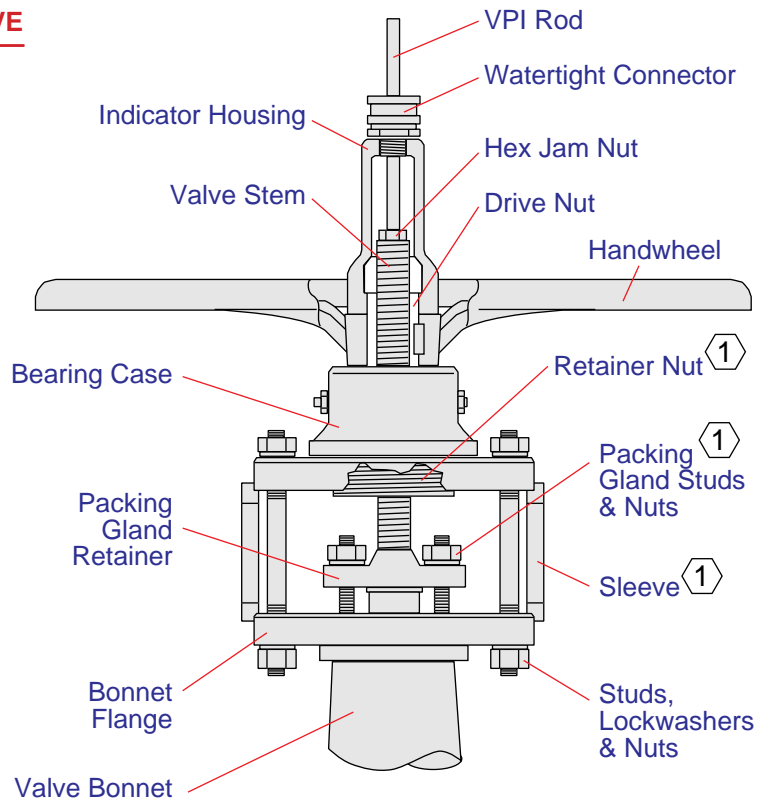

HANDWHEEL VALVE

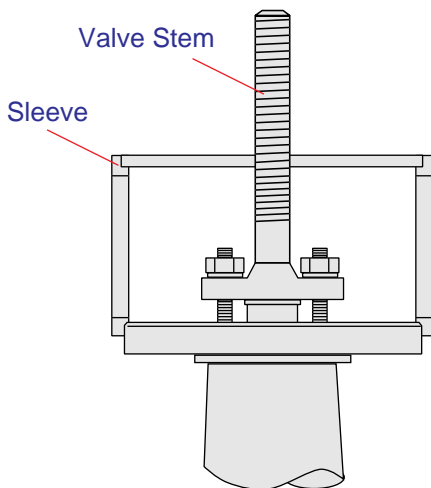

"L" VALVE

Ready for Actuator Attachment

FIGURE 25
Handwheel to "L" Valve (Procedure - 6B)

NOTE:
① Do not remove

INSTALLATION, continued

Refer to Figure 26 for steps 6 through 14. (Lubricate as noted in figure.)

6. Orientate the valve sleeve as shown in the figure.
(NOTE: Notice the different orientations for the different actuator models.)
7. Thread the actuator unit onto the valve stem (left hand threads) until the distance between the actuator flange and the valve sleeve is equal to the assembly dimension for the appropriate actuator.
(NOTE: When setting the assembly dimension, the valve is in the full-open position and the actuator is in the full-closed position.)
8. Orientate the actuator to the valve by noting the relationship of the lower gas inlet to the valve bore centerline.
(NOTE: Notice the different orientations for the different actuator models.)
9. Lower the actuator until the actuator flange and valve sleeve contact.
(NOTE: If they do not contact due to actuator spring compression, apply gas pressure to the lower gas inlet starting at 20 psig (1.4 bars) and increasing by steps of 5 psig (0.35 bars) until they contact.) (Do not exceed rated pressure stamped on the nameplate for the actuator.)

CAUTION:

Be sure hands and tools are not between the actuator flange and the valve sleeve, as the actuator will move quickly to make contact with the valve sleeve.

10. Check that the packing gland nuts on the valve (see Figure 25) are accessible with a wrench. If they are not accessible, the valve sleeve will need to be rotated until they are.
11. Install the position indicator plate bracket, studs, lock washers & nuts, and tighten to the appropriate torque, using a criss-cross pattern.
12. Install any accessories, not already installed, to the actuator unit or valve. Be sure the valve packing gland nuts are still accessible.
13. Lubricate the actuator and check/fill the gas-over-oil tank as described in the “MAINTENANCE” section on page 91. Adjust the spring compression as detailed in the “SPRING COMPRESSION ADJUSTMENT” section on page 54. Install and adjust the visual position indicator plates as detailed in the “INDICATOR PLATES (INSTALLATION & ADJUSTMENT)” section on page 52.
14. The actuator mounting is complete.

INSTALLATION, continued

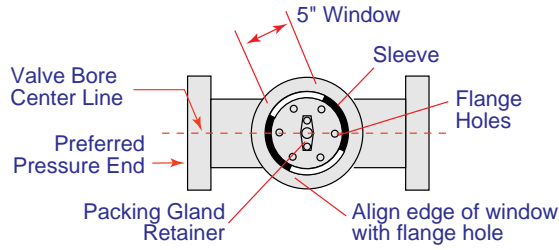

Sleeve to Valve Orientation

LS-185-D-26 Actuator Six (6) Hole Pattern

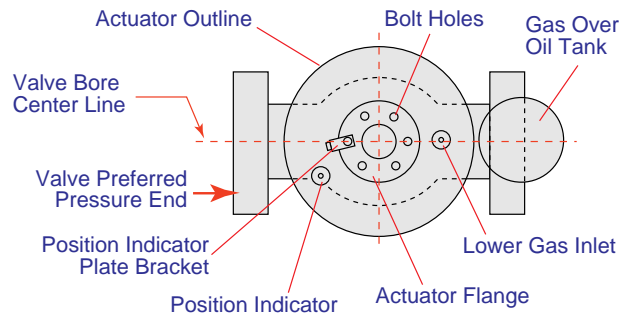

Actuator to Valve Orientation

LS-185-D-25 Six (6) Hole Pattern

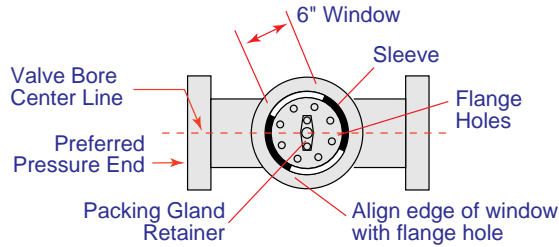

Sleeve to Valve Orientation

LS-185-D-15 Actuator Eight (8) Hole Pattern

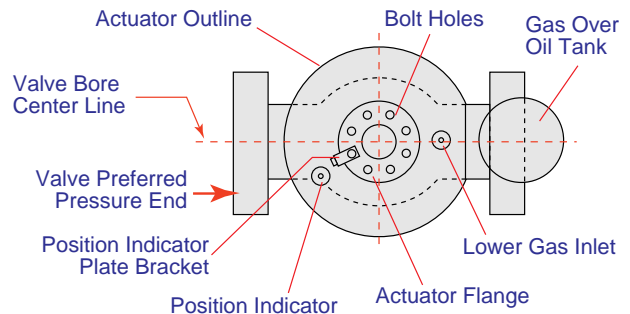

Actuator to Valve Orientation

LS-185-D-15 Eight (8) Hole Pattern

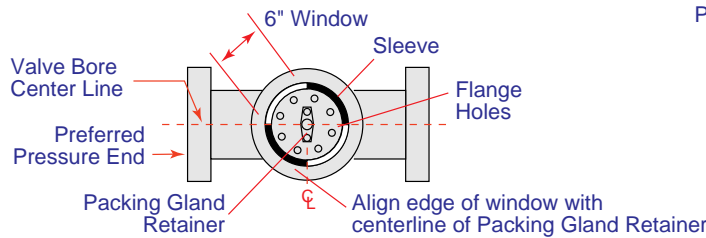

Sleeve to Valve Orientation

LS-205-D-15 Actuator Eight (8) Hole Pattern

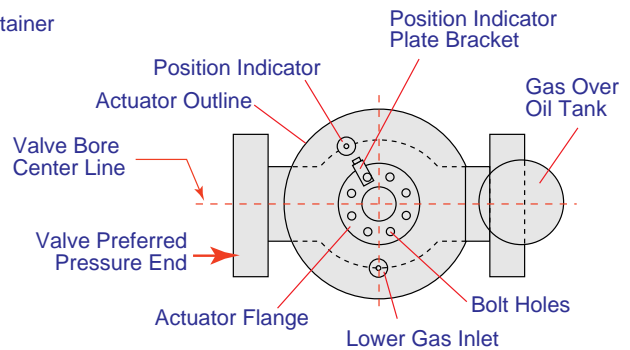

Actuator to Valve Orientation

LS-205-D-15 Eight (8) Hole Pattern

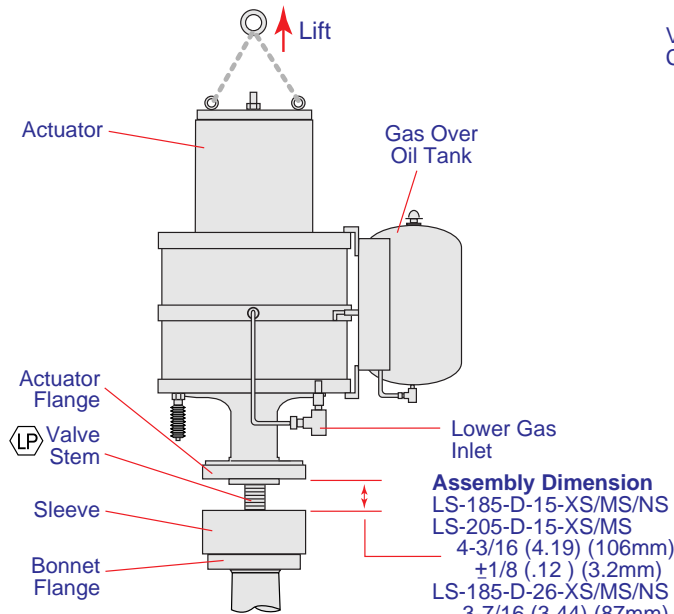

Assembly Dimensions

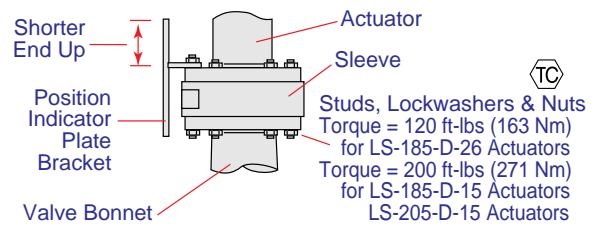

Indicator Plate Bracket Attachment

NOTES:

Ⓣ Apply FEL-PRO "C-102" anti-seize lubricant

Ⓛ Lubricate threads with Lubriplate "930-AA" prior to assembly

FIGURE 26
Actuator Mounting (Procedure - 6B)

INSTALLATION, continued

CONVERSION & MOUNTING PROCEDURE - 7B

WARNING: This mounting & conversion procedure is for “PREVIOUS” valve models with the closed bonnet configuration, Size & Pressures:

6x6, 8x6 ANSI 900 Class
8x8, 10x8 ANSI 400-600 Class
10x10, 12x10 ANSI 150-300 Class

BEFORE converting or mounting, be certain this is the correct procedure. Failure to do this could result in PERSONAL INJURY and/or equipment damage. See pages 11-14 for identifying other procedures.

Refer to Figure 27 for steps 1 through 10.

(NOTE: Steps 1 through 10 are omitted if the handwheel assembly has been removed and the adapter assembly has been previously mounted.)

1. Fully open valve with handwheel.
2. Remove the threaded stem protector with the watertight connector.
3. Remove the VPI rod with the hex jam nut.
4. Remove the handwheel and handwheel key.
5. Loosen the set screw and remove the threaded drive nut retainer.
6. Remove the drive nut (left hand threads), bearings, and races.
7. Thread the bonnet adapter flange onto the bonnet and turn it to the specified assembly dimension in the figure. Align two of the bolt holes with the valve bore centerline, see view AA.
8. Thread the lock ring into the adapter flange and tighten securely against the top of the bonnet. (NOTE: Maintain the proper adapter flange orientation.)
9. Tack weld two user supplied mild steel tabs (approximate size 3/16 x 3/4 x 3/4) (4 x 20 x 20 mm) to the bonnet adapter flange and the valve bonnet, approximately 180° apart.
10. Valve is now an “L” valve, as shown, and is ready for actuator attachment.

INSTALLATION, continued

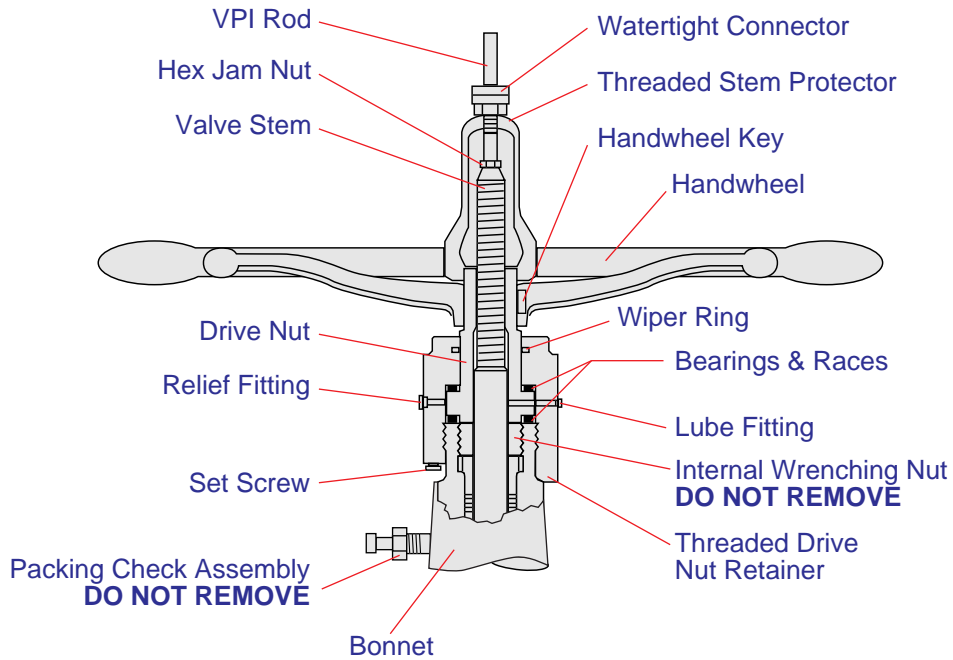

HANDWHEEL VALVE

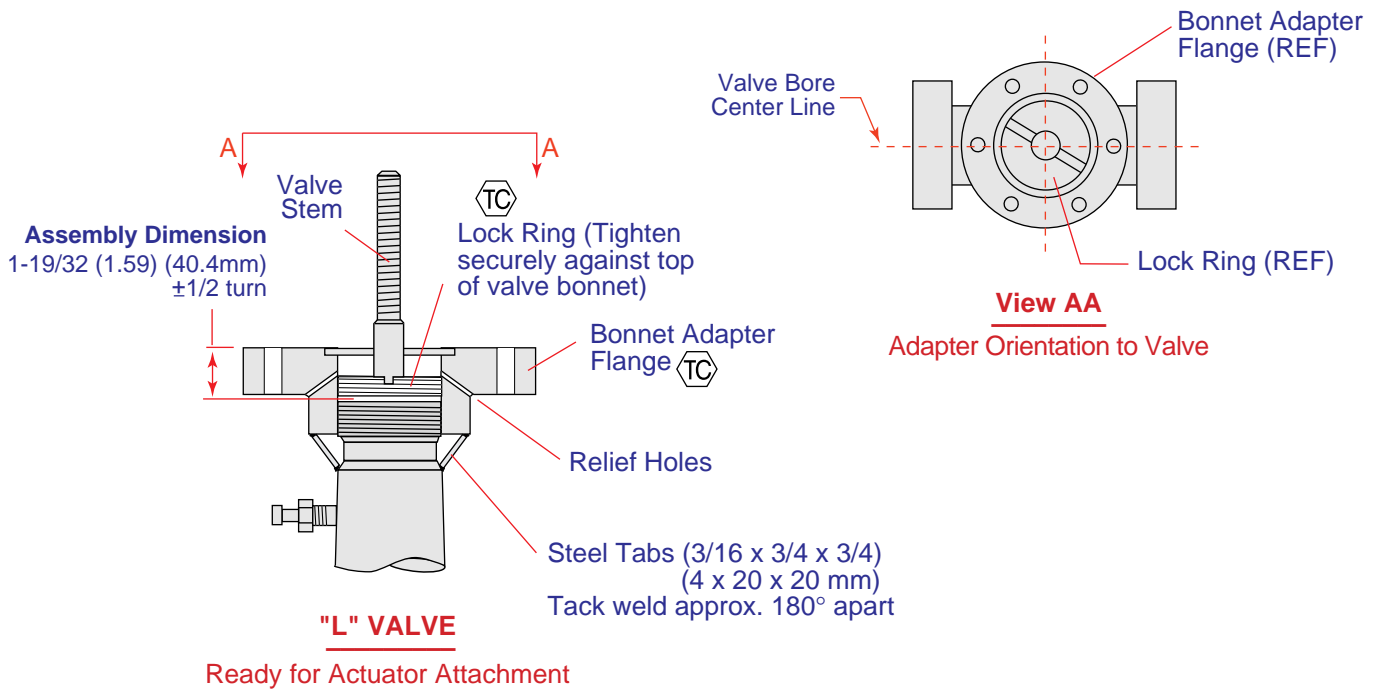

FIGURE 27
Handwheel to "L" Valve (Procedure - 7B)

NOTE:

TC Apply FEL-PRO "C-102" anti-seize lubricant

INSTALLATION, continued

Refer to Figure 28 for steps 11 through 17. (Lubricate as noted in figure.)

11. Thread the actuator unit onto the valve stem (left hand threads) until the distance between the actuator flange and the adapter flange is equal to the assembly dimension for the appropriate actuator. (NOTE: When setting the assembly dimension, the valve is in the full-open position and the actuator is in the full-closed position.)
12. Orientate the actuator to the valve by noting the relationship of the lower gas inlet to the valve bore centerline.
13. Lower the actuator until the actuator flange and adapter flange contact. (NOTE: If they do not contact due to actuator spring compression, apply gas pressure to the lower gas inlet starting at 20 psig (1.4 bars) and increasing by steps of 5 psig (0.35 bars) until they contact.) (Do not exceed rated pressure stamped on the actuator nameplate.)

CAUTION:

Be sure hands and tools are not between the actuator flange and the valve adapter flange, as the actuator will move quickly to make contact with the valve adapter flange.

14. Install the position indicator plate bracket, bolts, lock washers & nuts, and tighten to 120 ft-lbs (64 Nm) using a criss-cross pattern.
15. Install any accessories, not already installed, to the actuator unit or valve.
16. Lubricate the actuator and check/fill the gas-over-oil tank as described in the "MAINTENANCE" section on page 91. Adjust the spring compression as detailed in the "SPRING COMPRESSION ADJUSTMENT" section on page 54. Install and adjust the visual position indicator plates as detailed in the "INDICATOR PLATES (INSTALLATION & ADJUSTMENT)" section on page 52.
17. The actuator mounting is complete.

INSTALLATION, continued

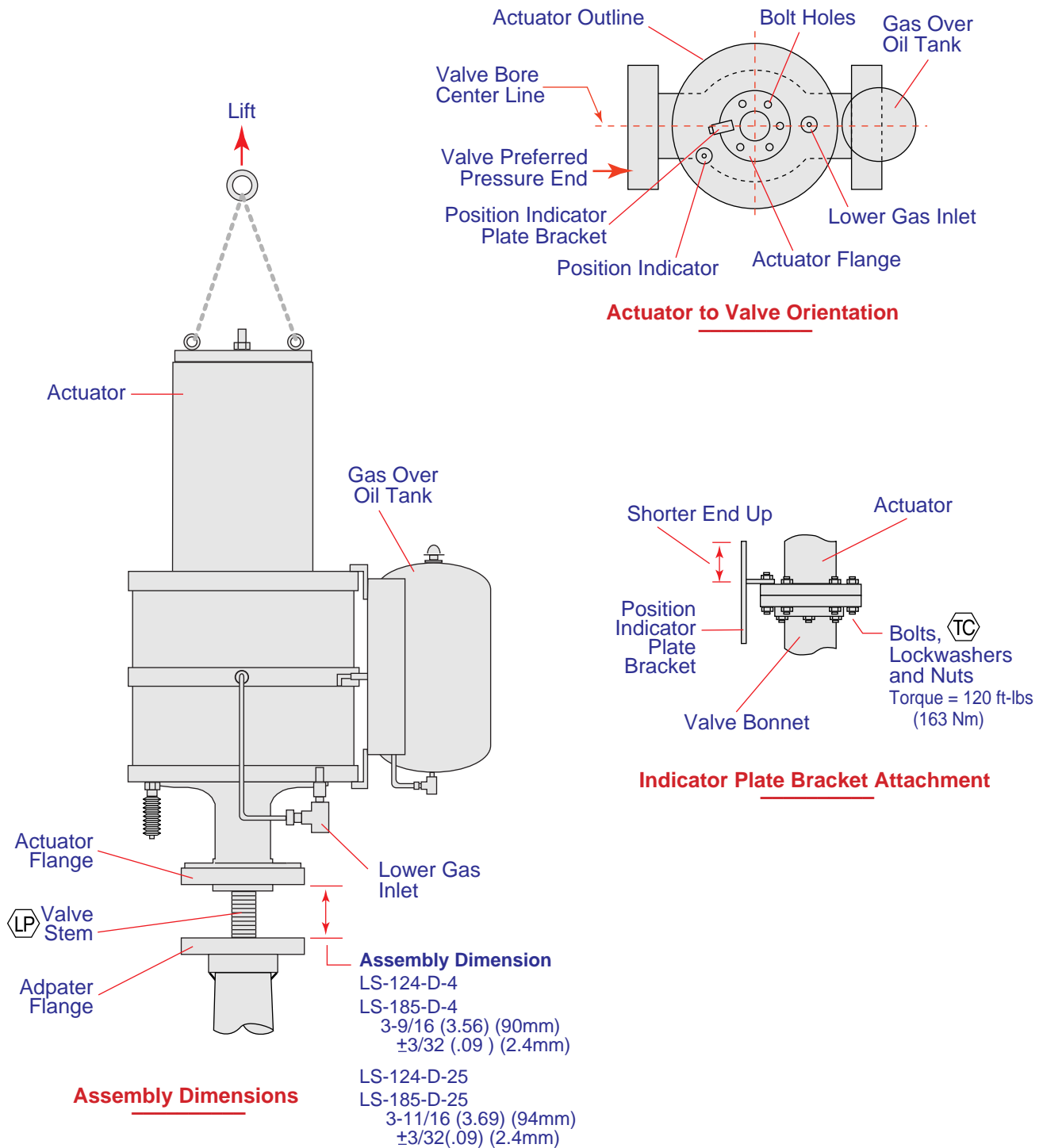

FIGURE 28
Actuator Mounting (Procedure - 7B)

NOTES:

- Ⓣ Apply FEL-PRO "C-102" anti-seize lubricant
- Ⓛ Lubricate threads with Lubriplate "930-AA" prior to assembly

INSTALLATION, continued

CONVERSION & MOUNTING PROCEDURE - 8B

WARNING: This mounting & conversion procedure is for “PREVIOUS” valve models with the O.S.&Y. bonnet configuration, Size & Pressures:

6x6, 8x6 ANSI 900 Class
8x8, 10x8 ANSI 400-600 Class
10x10, 12x10 ANSI 150-300 Class

BEFORE converting or mounting, be certain this is the correct procedure. Failure to do this could result in PERSONAL INJURY and/or equipment damage. See pages 11-14 for identifying other procedures.

Refer to Figure 29 for steps 1 through 5.

(NOTE: Steps 1 through 5 are omitted if the handwheel assembly has been removed.)

1. Fully open valve with handwheel.
2. Remove the studs, lock-washers & nuts that hold the bearing case & adapter to the bonnet adapter flange.
3. Remove the entire handwheel and bearing case & adapter assembly as one unit by unscrewing it from the valve stem. (Left hand valve stem threads.)
(NOTE: When it comes loose from the valve stem, lift it straight off the VPI rod.)
4. Remove the VPI rod and hex jam nut.
5. Valve is now an “L” valve, as shown, and is ready for actuator attachment.

INSTALLATION, continued

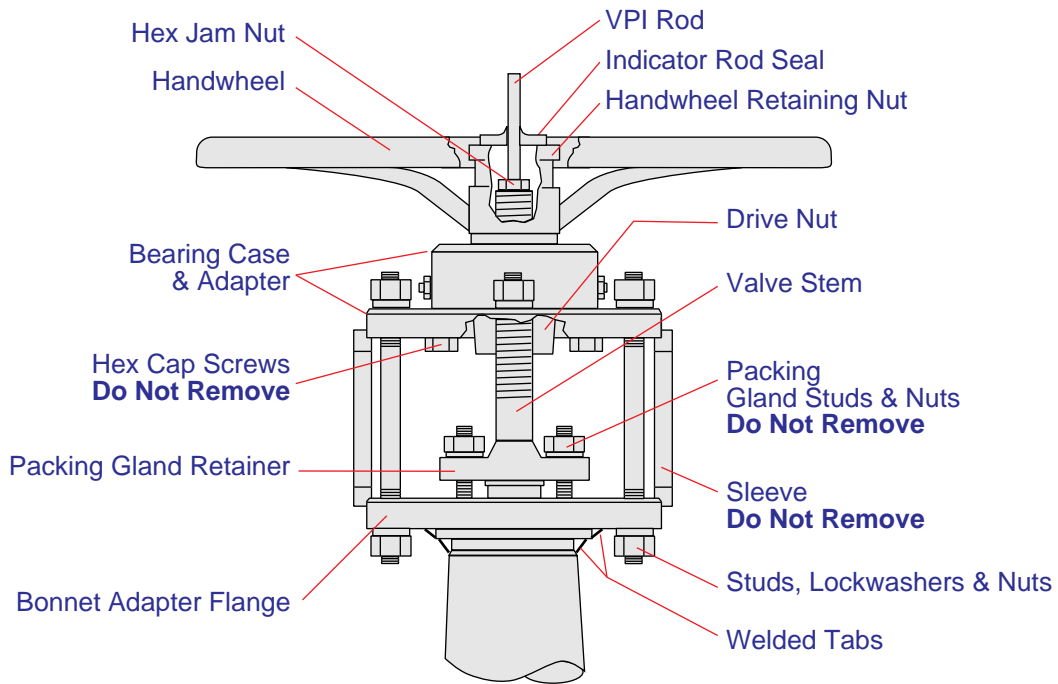

HANDWHEEL VALVE

FIGURE 29
Handwheel to "L" Valve (Procedure - 8B)

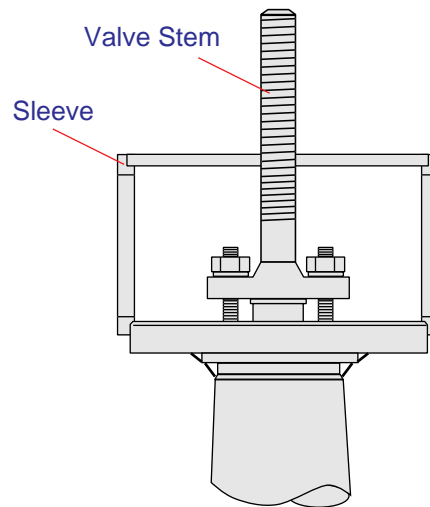

"L" VALVE

Ready for Actuator Attachment

INSTALLATION, continued

Refer to Figure 30 for steps 6 through 14. (Lubricate as noted in figure.)

6. Orientate the valve sleeve as shown in the figure.
7. Thread the actuator unit onto the valve stem (left hand threads) until the distance between the actuator flange and the valve sleeve is equal to the assembly dimension for the appropriate actuator. (NOTE: When setting the assembly dimension, the valve is in the full-open position and the actuator is in the full-closed position.)
8. Orientate the actuator to the valve by noting the relationship of the lower gas inlet to the valve bore centerline. (NOTE: Notice the two different orientations, one for valves with the flange holes on centerline and one for valves with holes straddling the centerline.)
9. Lower the actuator until the actuator flange and valve sleeve contact. (NOTE: If they do not contact due to actuator spring compression, apply gas pressure to the lower gas inlet starting at 20 psig (1.4 bars) and increasing by steps of 5 psig (0.35 bars) until they contact.) (Do not exceed rated pressure stamped on the nameplate for the actuator.)

CAUTION:

Be sure hands and tools are not between the actuator flange and the valve sleeve, as the actuator will move quickly to make contact with the valve sleeve.

10. Check that the packing gland nuts on the valve (see Figure 29) are accessible with a wrench. If they are not accessible the valve sleeve will need to be rotated until they are accessible.
11. Install the position indicator plate bracket, studs, lock washers & nuts, and tighten to the torque shown in figure 30, using a crisscross pattern.
12. Install any accessories, not already installed, to the actuator unit or valve. Be sure the valve packing gland nuts are still accessible.
13. Lubricate the actuator and check/fill the gas-over-oil tank as described in the "MAINTENANCE" section on page 91. Adjust the spring compression as detailed in the "SPRING COMPRESSION ADJUSTMENT" section on page 54. Install and adjust the visual position indicator plates as detailed in the "INDICATOR PLATES (INSTALLATION & ADJUSTMENT)" section on page 52.
14. The actuator mounting is complete.

INSTALLATION, continued

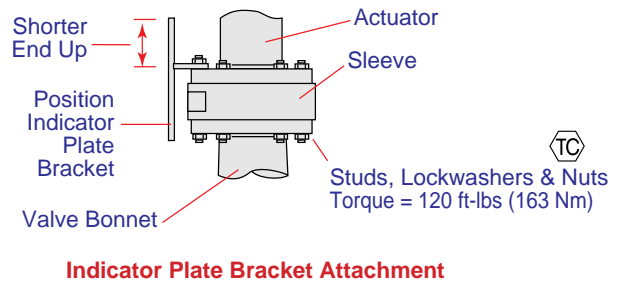
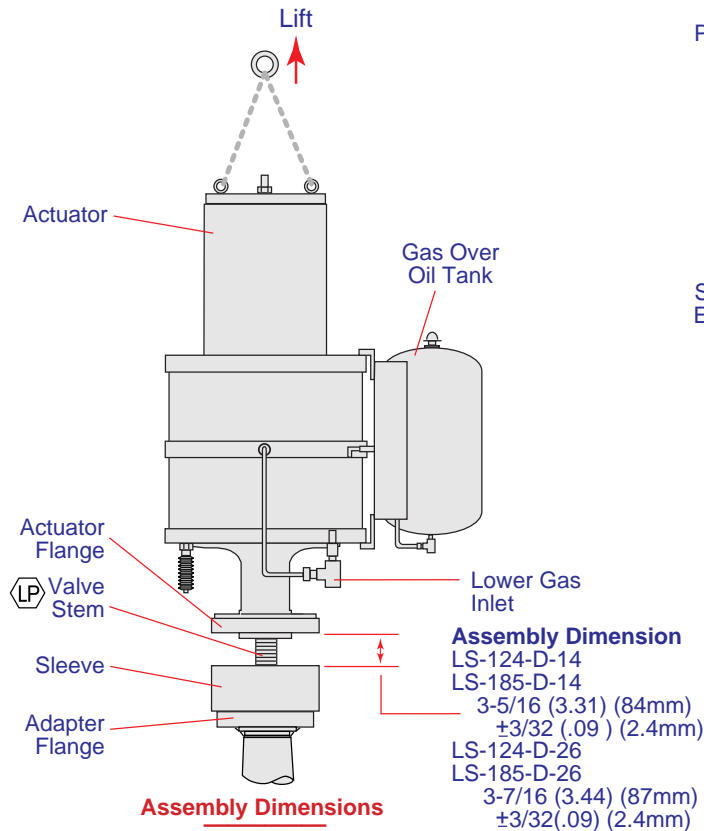
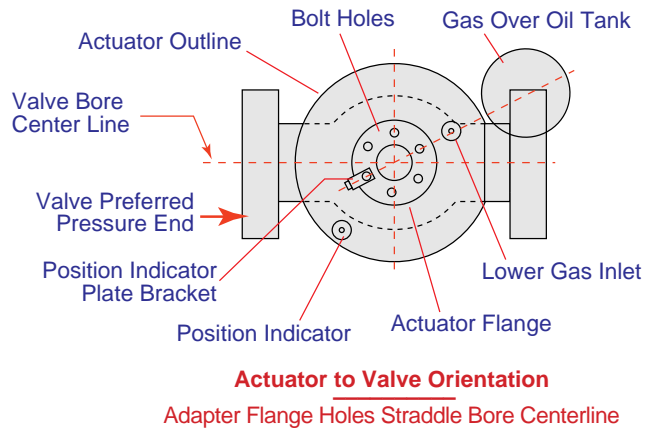
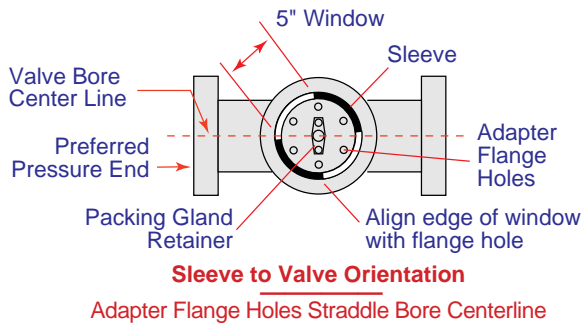
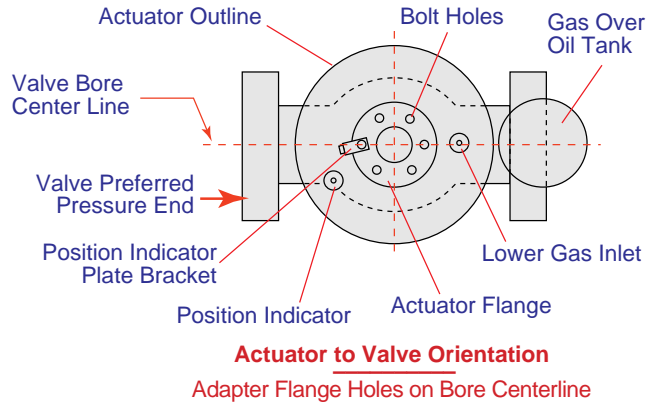
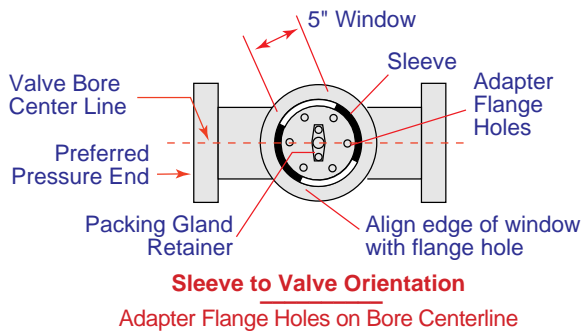

FIGURE 30
Actuator Mounting (Procedure - 8B)

- NOTES:**
- Apply FEL-PRO "C-102" anti-seize lubricant
 - Lubricate threads with Lubriplate "930- AA" prior to assembly

INSTALLATION, continued

CONVERSION & MOUNTING PROCEDURE - 9B

WARNING: This mounting & conversion procedure is for valve model “HC”, Sizes & Pressures:

6x6, 8x6 ANSI 1500-2500 CLASS
10x10, 12x10 ANSI 400-600 CLASS
12x12, 14x12, 16x12 ANSI 400-600 CLASS

This procedure is also for “PREVIOUS” valve models with the closed bonnet configuration, Sizes & Pressures:

10x10, 12x10 ANSI 400-600 CLASS
12x12, 14x12, 16x12 ANSI 400-600 CLASS

BEFORE converting or mounting, be certain this is the correct procedure. Failure to do this could result in PERSONAL INJURY and/or equipment damage. See pages 11-14 for identifying other procedures.

Refer to Figure 31 for steps 1 through 5.

(NOTE: Steps 1 through 5 are omitted if the handwheel assembly has been removed.)

1. Fully open valve with the handwheel.
2. Remove the bonnet flange nuts & bolts.
3. Turn the entire gearbox assembly (clockwise) until the unit comes loose from the valve stem and lift it off (gear box, adapter spool, drive nut with bearings, key and watertight connector).
4. Remove the VPI rod with the hex jam nut.
5. Valve is now an “L” valve, as shown, and is ready for actuator attachment.

INSTALLATION, continued

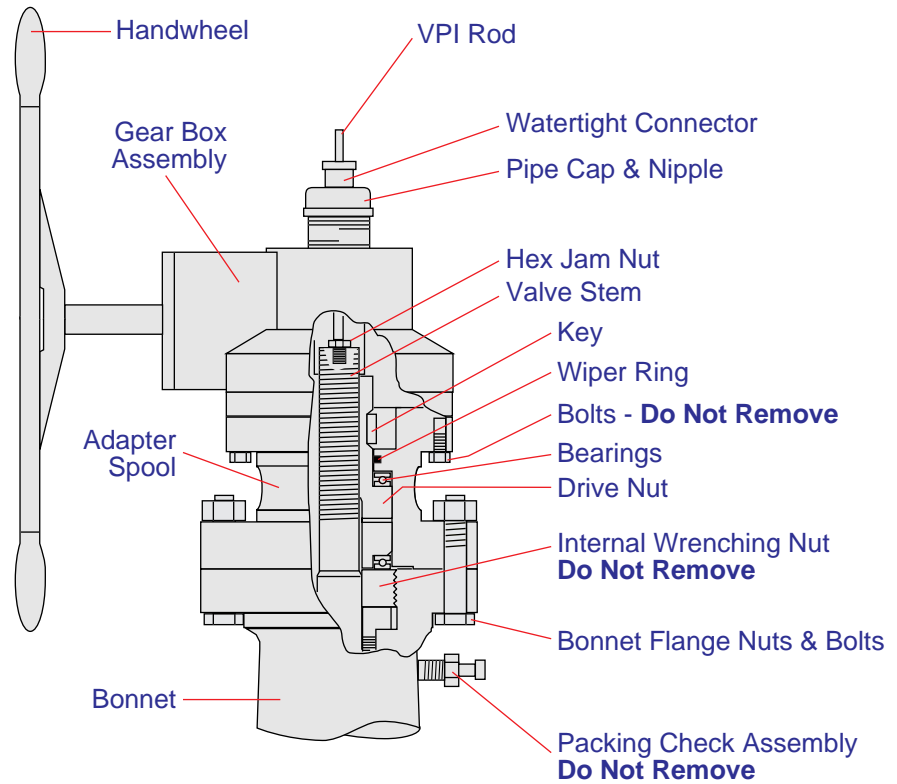

HANDWHEEL VALVE

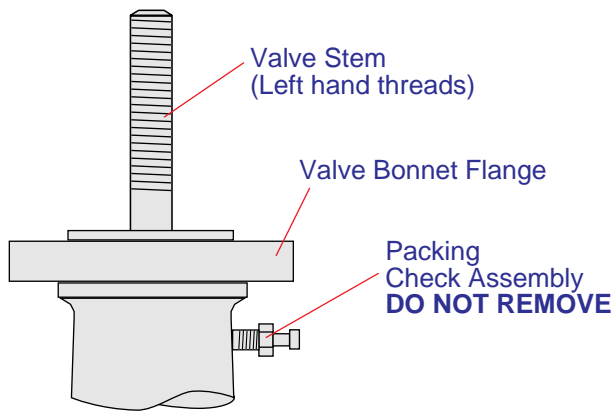

"L" VALVE

Ready for Actuator Attachment

FIGURE 31
Handwheel to "L" Valve (Procedure - 9B)

INSTALLATION, continued

Refer to Figure 32 for steps 6 through 12. (Lubricate as noted in figure.)

6. Thread the actuator unit onto the valve stem (left hand threads) until the distance between the actuator flange and the valve bonnet flange is equal to the assembly dimension for the appropriate actuator.
(NOTE: When setting the assembly dimension, the valve is in the full-open position and the actuator is in the full-closed position.)
7. Orientate the actuator to the valve by noting the relationship of the lower gas inlet to the valve bore centerline.
8. Lower the actuator until the actuator flange and valve bonnet flange contact.
(NOTE: If they do not contact due to actuator spring compression, apply gas pressure to the lower gas inlet starting at 20 psig (1.4 bars) and increasing by steps of 5 psig (0.35 bars) until they contact.) (Do not exceed rated pressure stamped on actuator nameplate.)

CAUTION:

Be sure hands and tools are not between the actuator flange and the valve bonnet flange, as the actuator will move quickly to make contact with the valve bonnet flange.

9. Install indicator plate bracket, bolts, lock washers & nuts, and tighten to the proper torque using a criss-cross pattern. (Torque = 200 ft-lbs (271 Nm).)
10. Install any accessories, not already installed, to the actuator unit or valve.
11. Lubricate the actuator and check/fill the gas-over-oil tank as described in the "MAINTENANCE" section on page 91. Adjust the spring compression as detailed in the "SPRING COMPRESSION ADJUSTMENT" section on page 54. Install and adjust the visual position indicator plates as detailed in the "INDICATOR PLATES (INSTALLATION & ADJUSTMENT)" section on page 52.
12. The actuator mounting is complete.

INSTALLATION, continued

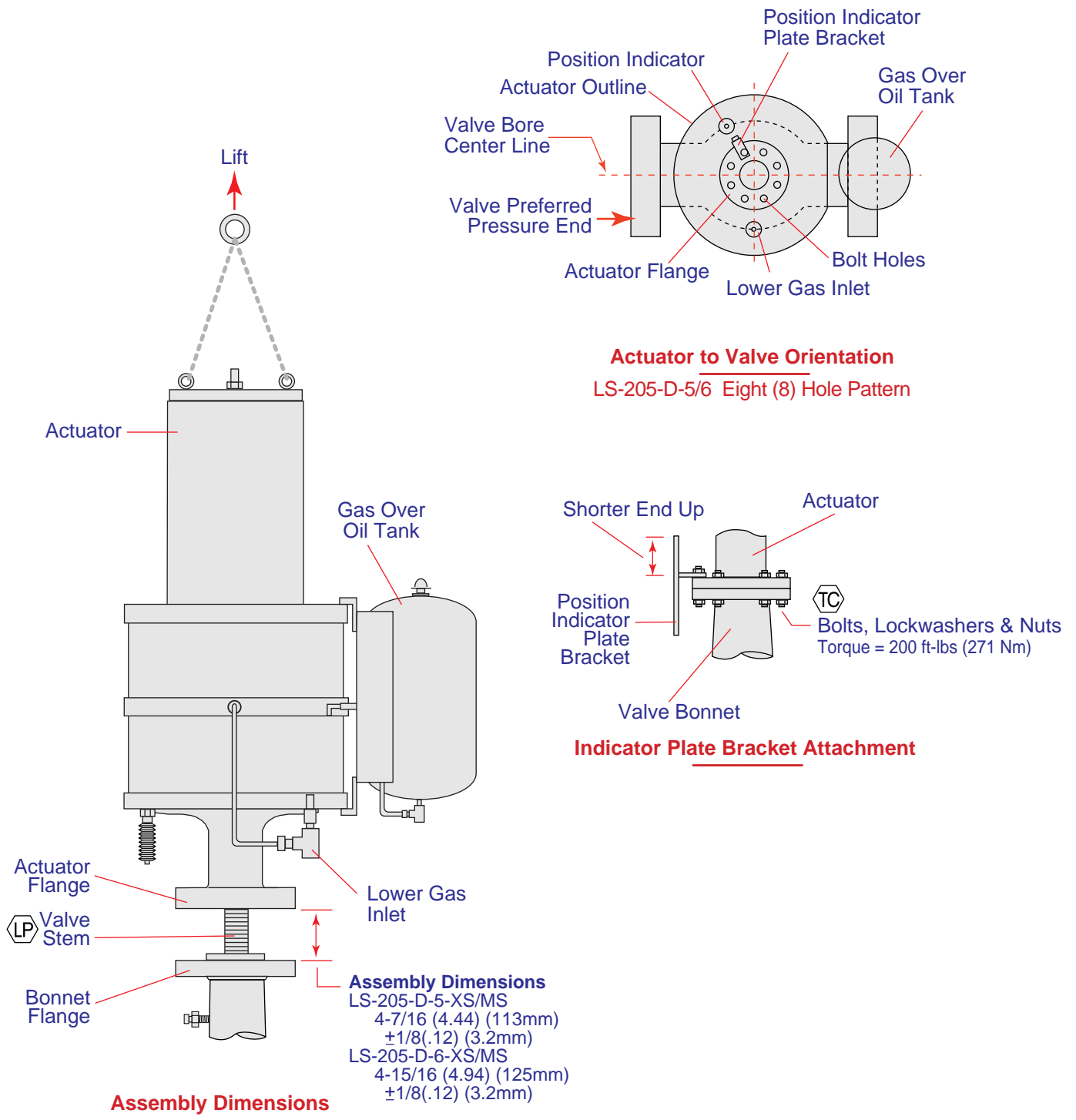

FIGURE 32
Actuator Mounting (Procedure - 9B)

NOTES:

- ⓧ Apply FEL-PRO “C-102” anti-seize lubricant
- ⓧ Lubricate threads with Lubriplate “930- AA” prior to assembly

INSTALLATION, continued

CONVERSION & MOUNTING PROCEDURE - 10B

WARNING: This mounting & conversion procedure is for valve model “HD”. Sizes & Pressures:

8x8, 10x8 ANSI 900 Class
10x10, 12x10 ANSI 400-900 Class
12x12, 14x12, 16x12 ANSI 400-600 Class

This procedure is also for “PREVIOUS” valve models with the OS&Y bonnet configuration. Sizes & Pressures:

8x8, 10x8 ANSI 900 Class
10x10, 12x10 ANSI 400-900 Class
12x12, 14x12, 16x12 ANSI 400-600 Class

BEFORE converting or mounting, be certain this is the correct procedure. Failure to do this could result in PERSONAL INJURY and/or equipment damage. See pages 11-14 for identifying other procedures.

Refer to Figure 33 for steps 1 through 5.

(NOTE: Steps 1 through 5 are omitted if the handwheel assembly has been removed.)

1. Fully open valve with the handwheel.
2. Remove the studs, lock washers & nuts that hold the spool to the sleeve.
3. Remove the entire gear box and adapter spool assembly as one unit by unscrewing it from the valve stem. (Left hand valve stem threads.)
(NOTE: When it comes loose from the valve stem, lift it straight off the VPI rod.)
4. Remove the VPI rod with the hex jam nut.
5. Valve is now an “L” valve, as shown, and is ready for actuator attachment.

INSTALLATION, continued

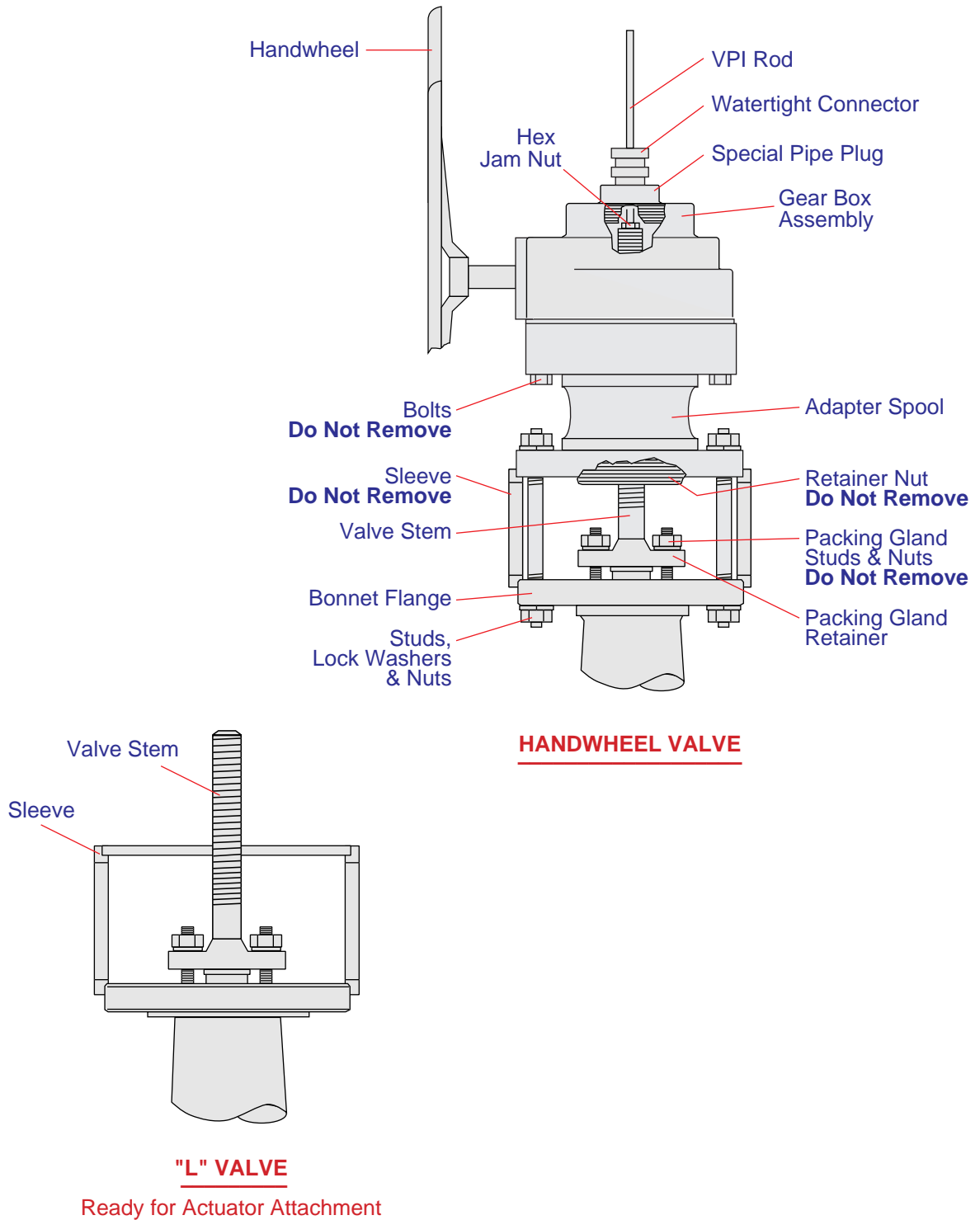

FIGURE 33
Handwheel to "L" Valve (Procedure - 10B)

INSTALLATION, continued

Refer to Figure 34 for steps 6 through 14. (Lubricate as noted in figure.)

6. Orientate the valve sleeve as shown in the figure.
7. Thread the actuator unit onto the valve stem (left hand threads) until the distance between the actuator flange and the valve sleeve is equal to the assembly dimension for the appropriate actuator.
(NOTE: When setting the assembly dimension, the valve is in the full-open position and the actuator is in the full-closed position.)
8. Orientate the actuator to the valve by noting the relationship of the lower gas inlet to the valve bore centerline.
9. Lower the actuator until the actuator flange and valve sleeve contact.
(NOTE: If they do not contact due to actuator spring compression, apply gas pressure to the lower gas inlet, starting at 20 psig (1.4 bars) and increasing by steps of 5 psig (0.35 bars) until they contact.) (Do not exceed rated pressure stamped on the nameplate for the actuator.)

CAUTION:

Be sure hands and tools are not between the actuator flange and the valve sleeve, as the actuator will move quickly to make contact with the valve sleeve.

10. Check that the packing gland nuts on the valve (see Figure 33) are accessible with a wrench. If they are not accessible, the valve sleeve will need to be rotated until they are.
11. Install the position indicator plate bracket, studs, lock washers & nuts, and tighten to the torque shown in figure, using a crisscross pattern. (Torque = 200 ft-lbs (271 Nm).)
12. Install any accessories, not already installed, to the actuator unit or valve. Be sure the valve packing gland nuts are still accessible.
13. Lubricate the actuator and check/fill the gas-over-oil tank as described in the "MAINTENANCE" section on page 91. Adjust the spring compression as detailed in the "SPRING COMPRESSION ADJUSTMENT" section on page 54. Install and adjust the visual position indicator plates as detailed in the "INDICATOR PLATES (INSTALLATION & ADJUSTMENT)" section on page 52.
14. The actuator mounting is complete.

INSTALLATION, continued

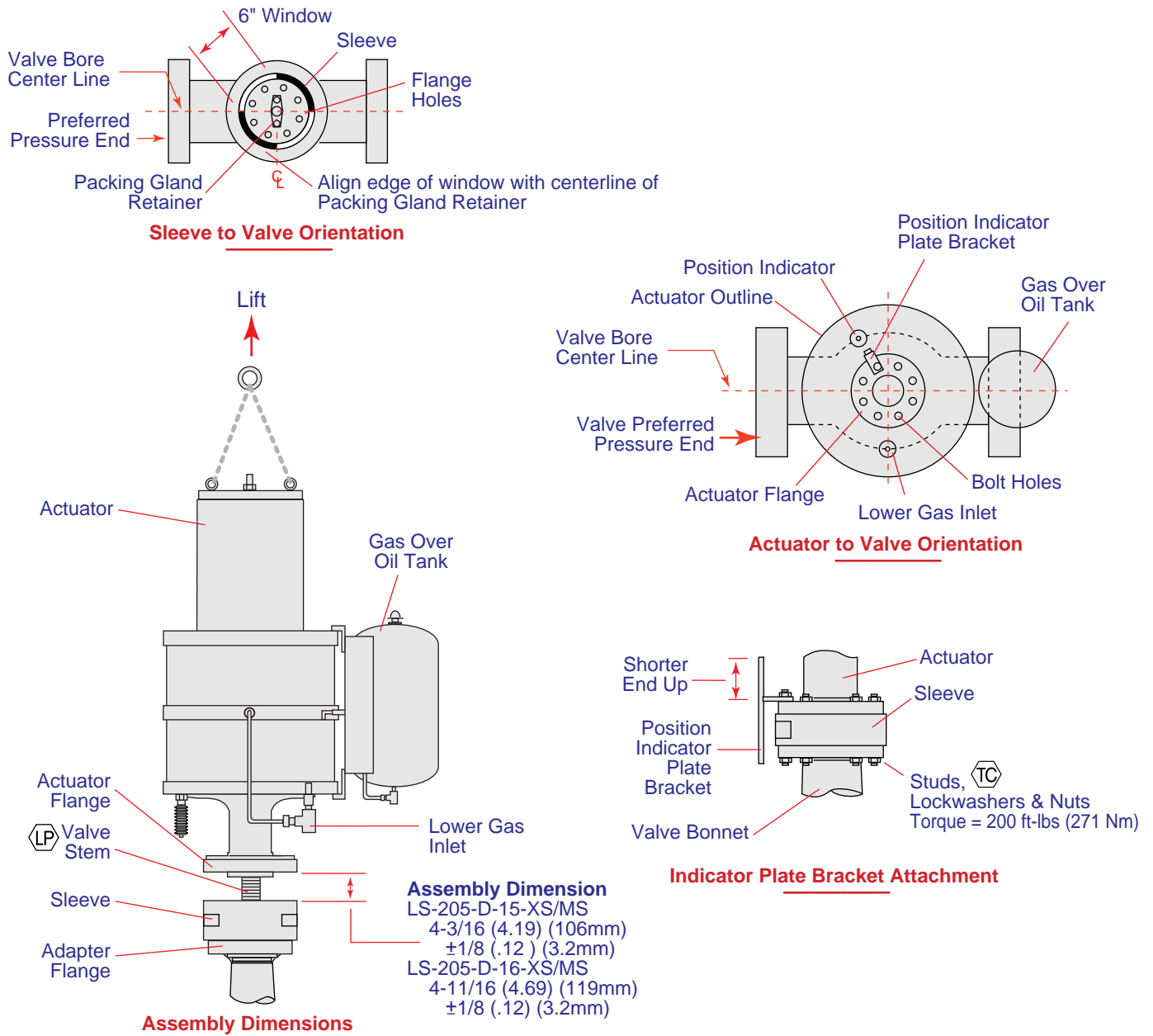

FIGURE 34
Actuator Mounting (Procedure - 10B)

NOTES:

- (TC) Apply FEL-PRO "C-102" anti-seize lubricant
- (LP) Lubricate threads with Lubriplate "930- AA" prior to assembly

INSTALLATION, continued

INDICATOR PLATES (INSTALLATION & ADJUSTMENT)

Refer to Figure 35.

1. Cycle the valve to the full open or full closed position.
2. Attach the corresponding plate with self-tapping screws so the pointer is over the bright band.
3. To determine if the valve is achieving full travel, measure the stroke of the pointer on the open & closed indicator plates. See NOMINAL VALVE STROKE CHART, next page, for approximate nominal valve travel.

NOTE: During the life of the valve, the stem travel will increase, thus causing the “closed” indicator plate to require readjustment to compensate for this additional travel.

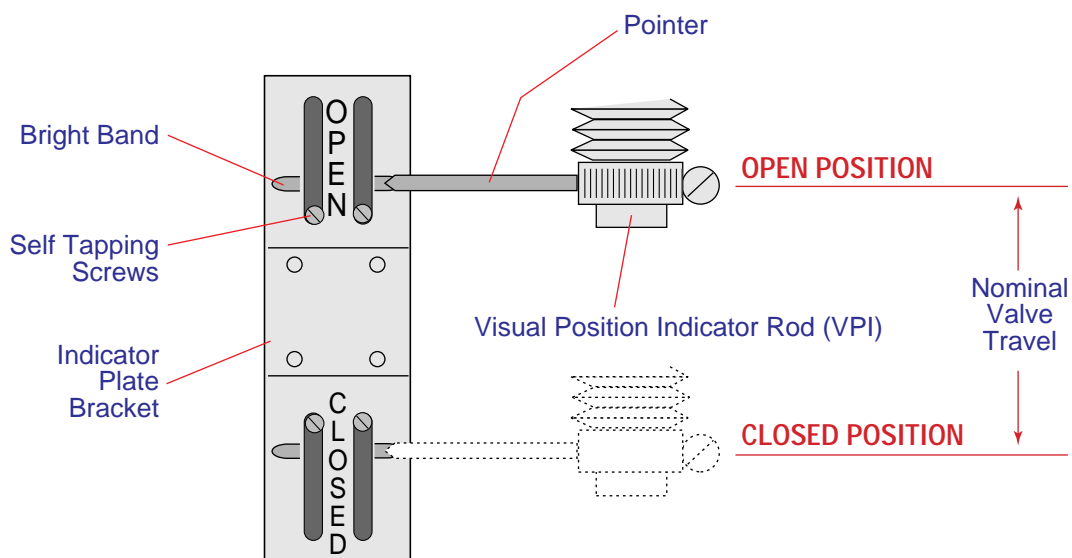

FIGURE 35
Indicator Plate Adjustment

INSTALLATION, continued

NOMINAL VALVE STROKE CHART See pages 11-14 for Valve Model Identification

Nom. Valve Size, Inch	ANSI CLASS	PREVIOUS MODELS NOMINAL TRAVEL, Inch and (mm)	MODELS JA, JB, HA, HB, HC, HD NOMINAL TRAVEL, Inch and (mm)	
2	900 THD	1-15/32" (37) to 1-21/32" (42)	1-11/32" (34) to 1-1/2" (38)	
	900 THD H8 900 FLG & BW 1500 2500	1-23/32" (44) to 1-15/16" (49)	1-5/8" (41) to 1-13/16" (46)	
3	150 300	1-23/32" (44) to 1-15/16" (49)	1-11/32" (34) to 1-1/2" (38)	
	150 ‡ 300	n/a	1-5/8" (41) to 1-13/16" (46)	
	400 600	2-7/32" (56) to 2-7/16" (62)	1-5/8" (41) to 1-13/16" (46)	
	900 1500	2-7/32" (56) to 2-7/16" (62)	2-1/8" (54) to 2-3/8" (60)	
	2500	n/a	2-19/32" (66) to 2-7/8" (73)	
4	150 300	2-7/32" (56) to 2-7/16" (62)	1-5/8" (41) to 1-13/16" (46)	
	150 ‡ 300	n/a	2-1/8" (54) to 2-3/8" (60)	
	400 600 900	2-7/32" (56) to 2-7/16" (62)	2-1/8" (54) to 2-3/8" (60)	
	1500 2500	2-3/8" (60) to 2-21/32" (67) n/a	2-9/32" (58) to 2-9/16" (65) 3-5/32" (80) to 3-1/2" (89)	
	150 300	2-3/8" (60) to 2-21/32" (67)	2-9/32" (58) to 2-9/16" (65)	
6	400 600	2-27/32" (72) to 3-5/32" (80)	2-31/32" (75) to 3-5/16" (84)	
	900	3-5/32" (80) to 3-1/2" (89)	3-9/32" (83) to 3-21/32" (93)	
	1500 2500	n/a n/a	3-3/16" (97) to 4-1/4" (108) 3-7/8" (98) to 4-5/16" (110)	
	150 300	2-27/32" (72) to 3-5/32" (80)	2-29/32" (74) to 3-1/4" (82)	
	600 900	3-5/32" (80) to 3-1/2" (89) 4-1/16" (103) to 4-1/2" (114)	3-9/32" (83) to 3-21/32" (93) 4-1/16" (103) to 4-1/2" (114)	
10	150 300	3-5/32" (80) to 3-1/2" (89)	3-9/32" (83) to 3-21/32" (93)	
	600	4-1/16" (103) to 4-1/2" (114)	4-1/16" (103) to 4-1/2" (114)	
	900	4-1/2" (114) to 5" (127)	4-1/2" (114) to 5" (127)	
12	150 300	4-1/16" (103) to 4-1/2" (114)	4-1/16" (103) to 4-1/2" (114)	
	600	4-1/2" (114) to 5" (127)	4-1/2" (114) to 5" (127)	
	900	5-9/32" (134) to 5-7/8" (149)	5-9/32" (134) to 5-7/8" (149)	
16	150 300 400 600	5-9/32" (134) to 5-7/8" (149)	5-9/32" (134) to 5-7/8" (149)	
	SIZE	API RATING	PREVIOUS MODELS	MODELS JA, HA, HC
	2	1000 2000	1-15/32" (37) to 1-21/32" (42)	1-11/32" (34) to 1-1/2" (38)
		3000 5000	1-23/32" (44) to 1-15/16" (49) n/a	1-5/8" (41) to 1-13/16" (46) 2" (51) to 2-1/4" (57)
2-1/2		2000 3000	2-7/32" (56) to 2-7/16" (62)	2-1/8" (54) to 2-3/8" (60)
	5000	n/a	2-19/32" (66) to 2-7/8" (73)	
	3	1000 2000 3000	2-7/32" (56) to 2-7/16" (62)	2-1/8" (54) to 2-3/8" (60)
5000		n/a	2-19/32" (66) to 2-7/8" (73)	
4		1000 2000	2-7/32" (56) to 2-7/16" (62)	2-1/8" (54) to 2-3/8" (60)
		3000	2-3/8" (60) to 2-21/32" (67)	2-9/32" (58) to 2-9/16" (65)

INSTALLATION, continued

SPRING COMPRESSION ADJUSTMENT

Adjustment of the spring compression is critical for the proper operation of a valve with a spring-close actuator. The spring adjustment is done with the actuator attached to the valve, with the valve de-pressurized, and an accurate pressure gauge (0-100 psig, 0-10 bars). The adjustment is done as follows:

I. NON-ADJUSTABLE TYPE SPRING ADJUSTMENT (ACME THREADED STEM) TYPE N

Proper adjustment of the spring is achieved by turning the handwheel until the hole in the stem lines up with the thru hole in the debris cover. The lock pin is then inserted and cotter hair pin installed. Refer to figure 36.

II. ADJUSTABLE TYPE SPRING ADJUSTMENT

Refer to figure 36.

1. Loosen jam nut. (LS-205 with manual two-way mechanism does not have a jam nut).
2. Be sure spring compression is released by turning the spring adjusting screw or handwheel counter clockwise to at least the dimension shown in the table below:

Actuator Size	“A” Inch (mm)	“B” Inch (mm)
LS-124	7" (178)	11" (279)
LS-185	9" (229)	14" (356)
LS-205	10" (254)	4" (102)

3. Open the valve using the gas (air) pressure indicated on the valve/actuator name-plate. Usually 75-80 psig (5.1 - 5.5 bars).
4. Mark the position of the pointer on the visual position indicator plate bracket. (NOTE: If the open indicator plate is attached, it can be adjusted to show this position.) This gives the full open position of the valve.
5. Bleed the gas (air) pressure from actuator.
6. Make a rough spring setting by turning the spring adjustment screw or handwheel clockwise to the direction shown in the “Rough Spring Setting Chart” below:

ROUGH SETTING CHART - Set Dimension ±1/4 (.25) (6 mm)		
Actuator Size	“A” Inch (decimal) (mm)	“B” Inch (decimal) (mm)
LS-124 D-2/12/21/22	4-9/16" (4.56) (116)	8-9/16" (8.56) (217)
D-3/4/13/14/23/24/25/26	5-1/4" (5.25) (133)	9-1/4" (9.25) (235 mm)
D-20	4-11/16" (4.69) (119)	8-11/16" (8.69) (221)
D-27	4-3/16" (4.19)(106)	9-3/16" (8.19) (208)
LS-185-D-4/25	6" (6.00) (152)	11-7/16" (11.44) (291)
D-14/26	5-3/4" (5.75) (146)	11-3/16" (11.19) (284)
D-5	6-7/8" (6.88) (175)	12-5/16" (12.31) (313)
D15	6-5/8" (6.62) (168)	12-1/16" (12.06) (306)
D-20	5-7/16" (5.44) (138)	10-7/8"(10.88) (276)
LS-205-D-5	6-1/8" (6.12) (155)	1/2" (.50) (13)
D-6	6-5/8" (6.62) (168)	1" (1.00) (25)
D-15	5-7/8" (5.88) (149)	1/4" (.25) (6)
D-16	6-3/8" (6.38) (162)	3/4" (.75) (19)
D-26	7-1/4" (7.25) (184)	

INSTALLATION, continued

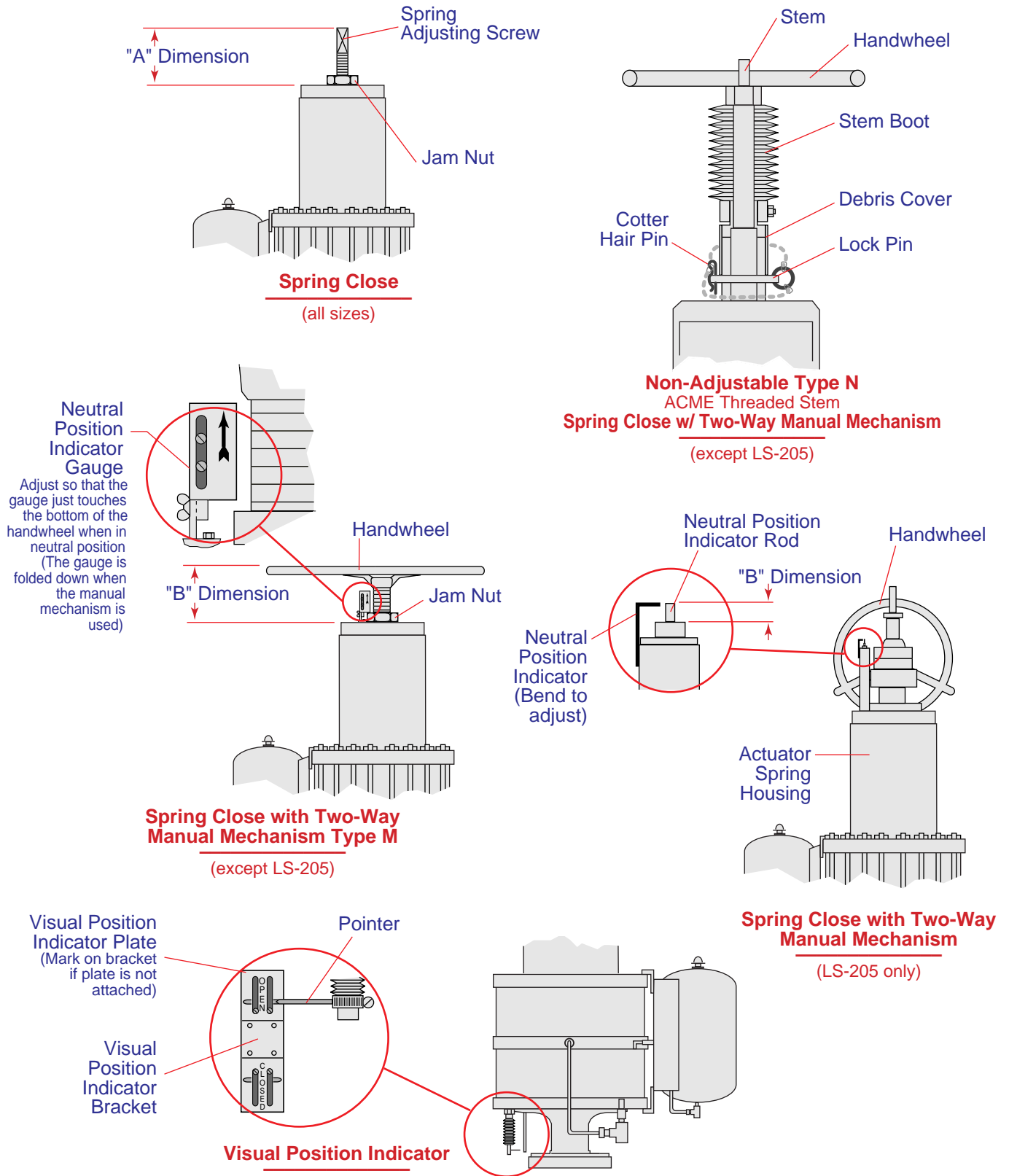

FIGURE 36
Spring Compression Adjustment

INSTALLATION, continued

7. Adjust the gas (air) pressure for the actuator as shown in the “Standard Spring Adjustment Chart” below, using an accurate pressure gauge.

STANDARD SPRING ADJUSTMENT CHART	
ACTUATOR SIZE	① GAS PRESSURE SET POINT ② ±1 PSIG (±.07 bars)
LS-124	71 PSIG (4.9 bars)
LS-185	65 PSIG (4.5 bars)
LS-205	67 PSIG (4.6 bars)
LS-205-D-26	③ 50 PSIG (3.5 bars)

NOTES:

- ① Set point based on actuator operating pressure of 75-80 PSIG (5.1-5.5 bars)
- ② When actuator operating pressure is 50-55 PSIG (3.4-3.8 bars) set point is 46 PSIG (3.2 bars)
- ③ Limited application - operating pressure of 60-65 PSIG (4.2-4.6 bars)

8. Open the valve actuator using the gas (air) pressure as listed above, while observing the pressure gage and the movement of the pointer on the visual position indicator bracket.
 - (a) POINTER DID NOT RETURN TO MARK ON INDICATOR PLATE BRACKET (after set pressure is reached). This indicates there is too much spring compression. The spring adjusting screw or handwheel should be turned counterclockwise ↺ until the pointer just returns to the mark.
 - (b) POINTER RETURNED TO MARK ON INDICATOR PLATE BRACKET (before set pressure is reached). This indicates insufficient spring compression. The spring adjusting screw or handwheel should be turned clockwise ↻ until the pointer just barely moves downward ↓.
 - (c) POINTER RETURNED TO MARK ON INDICATOR PLATE BRACKET (just as set pressure is reached). This is the proper adjustment.
9. Cycle valve two or three times to be sure the valve returns to the full-open position (mark on visual position indicator plate bracket). If it does not return, repeat Step 8.
10. Tighten the jam nut. (LS-205 with manual two-way mechanism does not have a jam nut.)
11. On spring-close actuators with manual two-way mechanism:
 - LS-124 & LS-185 Actuators - Adjust the indicator gage so that it just touches the bottom of the handwheel.
 - LS-205 Actuators - Bend the neutral position indicator so that it is within 1/8 inch (3 mm) of the top of the neutral position indicator rod.
12. Re-set actuator gas (air) pressure to the pressure indicated on the valve/actuator nameplate, usually 75-80 psig (5.1 - 5.5 bars).
13. Install and/or adjust the indicator plates on the indicator plate bracket as outlined in the “Indicator Plate (Installation & Adjustment)” section. See page 52.

ACTUATOR REPAIR

ACTUATOR REMOVAL FROM VALVE

NOTE: When the actuator is not to be repaired, but only removed from the valve, then the gas-over-oil tank, instrumentation panel, piping, pressure reserve tank, and any other accessories may remain attached to the actuator if it does not interfere with removal.

1. Cycle the valve/actuator to the full-open position. Drain the fluid from the gas-over-oil tank by removing the drain plug, slowly and cautiously, as the fluid will drain rapidly. Discard fluid. **DO NOT RE-USE.** See Figure 37 for drain plug location. (Note: If the actuator or valve is inoperative and cannot be opened, the fluid may be drained from the gas-over-oil tank in whatever position the valve/actuator is in. However, a quantity of fluid will be trapped inside the actuator.)
2. Slowly bleed the pressure from the actuator to allow the valve/actuator to close. Disconnect the gas (air) supply line.

ACTUATORS WITH "V" THREADED STEM (TYPE-M)

3. Refer to Figure 38 below. Loosen the jam nut (Note: LS-205 with manual two-way mechanism does not have a jam nut). Release the spring compression by turning the spring adjusting screw or handwheel counterclockwise until it turns freely. (This relaxes the spring compression.)

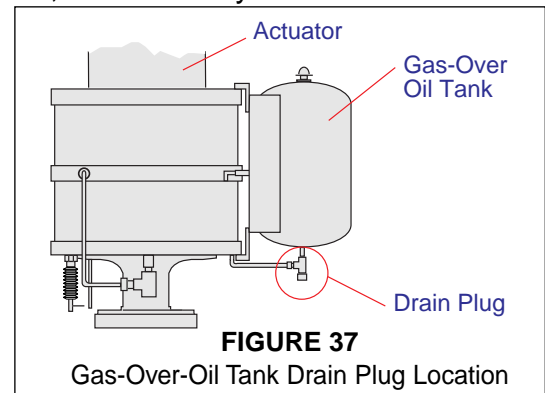

ACTUATORS WITH ACME THREADED STEM (TYPE-N-) (LS-124 & LS-185)

3. Refer to Figure 38 below. Remove lock pin. Release the spring compression by turning the spring adjusting screw or handwheel counterclockwise until it turns freely. (This relaxes the spring compression.)

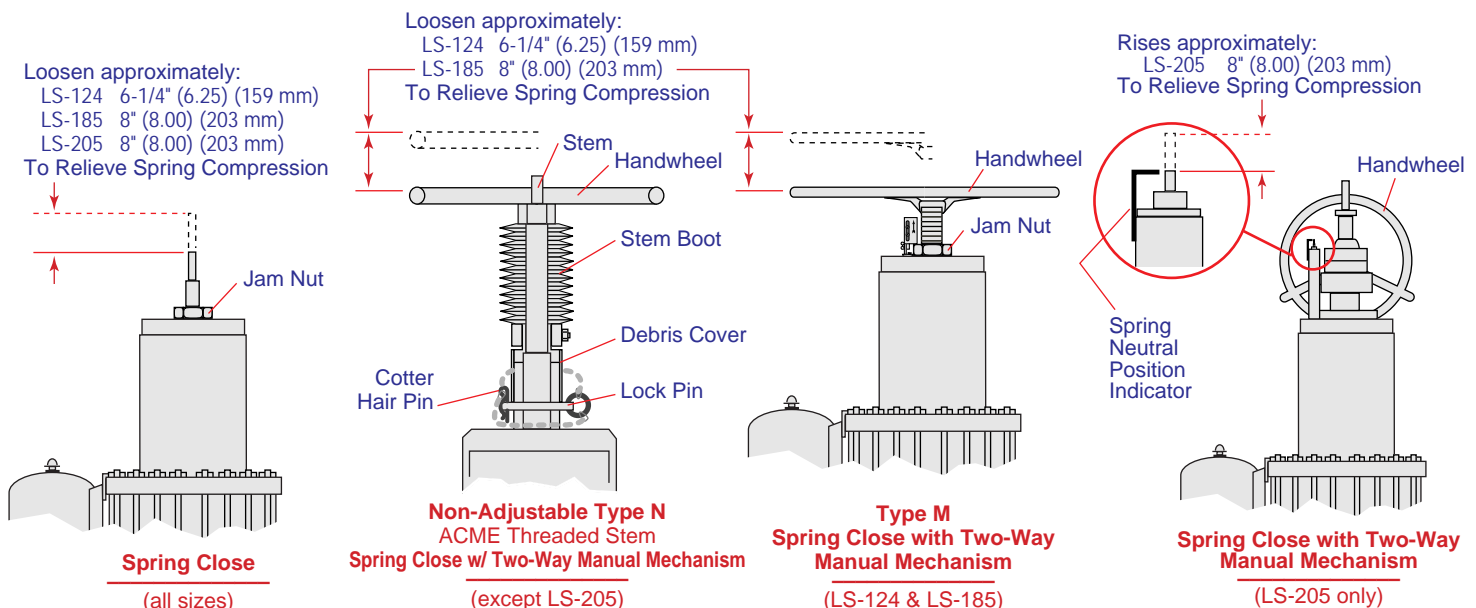

FIGURE 38
Releasing Spring Compression

ACTUATOR REPAIR, continued

Refer to Figure 39 for Steps 4 through 9.

4. Note the orientation of the actuator to the valve and any accessories attached to the valve/actuator combination.
(Note: If necessary, make a sketch or take a Polaroid or digital photo of the orientation.)
5. Remove the gas-over-oil tank, the instrumentation panel (if used), and the piping. (Note: Useful information may be found in the "Gas-Over-Oil Tank and Piping Removal and Installation" section on page 59 and in the "Instrumentation Panel" section on page 93).
6. Remove any additional accessories. (Sections on the CX Micro Switch and pressure reserve tanks are included in the accessory section of this manual.)
7. Remove the bolts or studs that hold the actuator flange to the bonnet flange or to the bonnet adapters. Remove the position indicator bracket.
(Note: Orbit recommends that the valve be depressurized any time an actuator is unbolted from a valve.)
8. Remove the actuator unit by rotating the actuator on the valve stem threads.
(Left hand threads.)
9. Actuator is ready to be disassembled for repair. (Note: Disassembly should be done on a clean work bench in a clean work area.)

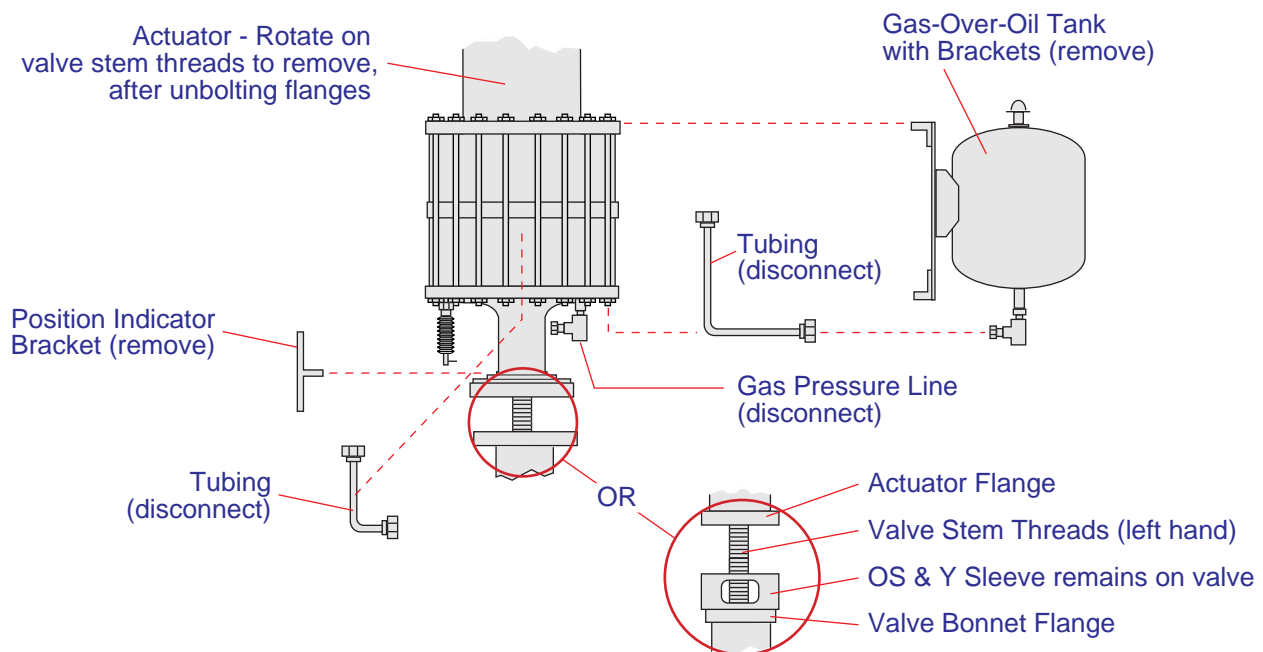

FIGURE 39
Actuator Removal from Valve

ACTUATOR REPAIR

GAS-OVER-OIL TANK AND PIPING REMOVAL & INSTALLATION

For removal and installation refer to:

Figure 40 for size “LS-124” - page 60

Figure 41 for size “LS-185” - page 61

Figure 42 for size “LS-205” - page 62

REMOVAL

1. Drain the fluid from the gas-over-oil tank. (Note: To drain, cycle the valve/actuator to the full open position. Drain the fluid from the tank by removing the drain plug slowly and cautiously, as the fluid will drain rapidly. Discard fluid. **DO NOT REUSE**. See figures for the drain plug location. If the actuator or valve is inoperative, the fluid may be drained in whatever position the valve/actuator is in, but a quantity of fluid will be trapped inside the actuator.)
2. Slowly bleed the pressure from the actuator to allow the valve/actuator to close. Disconnect the gas (air) supply line.
3. Remove the piping and tubing. A sketch, Polaroid or digital photo may be helpful for reassembly. (Note: Generally, only the tubing needs to be disconnected. The pipe fittings and tubing fittings may remain installed, unless damaged or leaking. If optional instrumentation panel is installed, remove panel as an assembly. See page 93 for panel removal.)
4. Note the position of the gas-over-oil tank in relation to the lower gas inlet. Remove tank. (NOTE: The figures show the standard tank orientation; however, some tanks may have different orientations to meet special requirements of some customers.)

INSTALLATION

1. Install gas-over-oil tank to actuator. Be sure the orientation to the lower gas inlet is correct.

NOTE: The tank must be mounted in a vertical and upright position, regardless of the orientation of the valve/actuator. This may require different brackets and additional fittings for some valve/ actuator orientations.

2. Install tubing and piping. (Install instrumentation panel, if so equipped.)

WARNING:
NEVER use thread tape on pipe or tubing fittings.
Use Loctite pipe compound or equivalent.
Tape particles can cause internal damage to the actuator instrumentation, requiring a complete disassembly of the actuator to repair.

3. Check that all the bolts, tubing, and pipe fittings are tight.
4. Fill the gas-over-oil tank as described in the “MAINTENANCE” section on page 92. (Note: If the actuator is not mounted to a valve, wait until it is mounted, to fill the tank.)

ACTUATOR REPAIR, continued

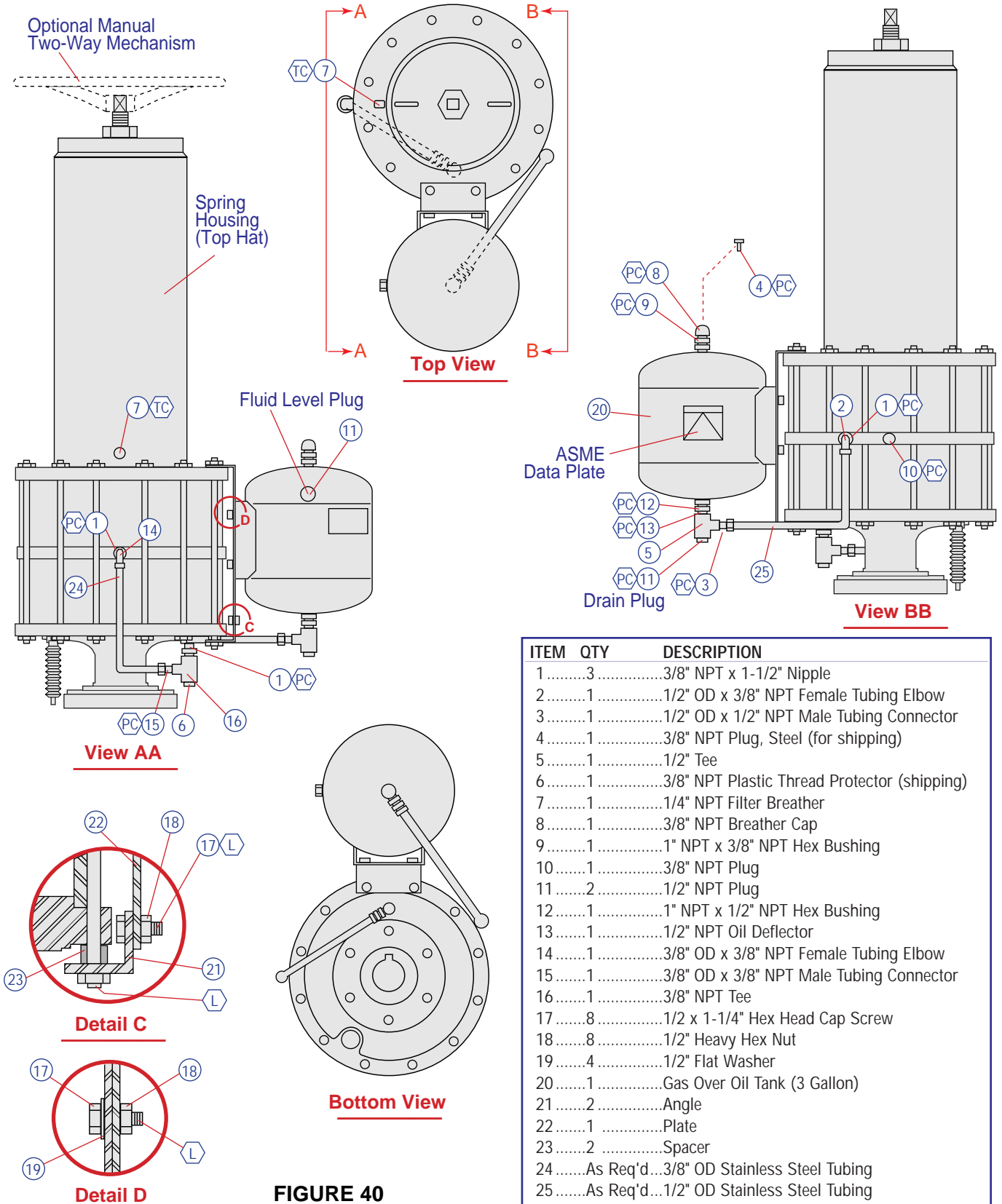

FIGURE 40
 "LS-124" Standard Gas/Oil
 Tank and Piping

ITEM	QTY	DESCRIPTION
1	3	3/8" NPT x 1-1/2" Nipple
2	1	1/2" OD x 3/8" NPT Female Tubing Elbow
3	1	1/2" OD x 1/2" NPT Male Tubing Connector
4	1	3/8" NPT Plug, Steel (for shipping)
5	1	1/2" Tee
6	1	3/8" NPT Plastic Thread Protector (shipping)
7	1	1/4" NPT Filter Breather
8	1	3/8" NPT Breather Cap
9	1	1" NPT x 3/8" NPT Hex Bushing
10	1	3/8" NPT Plug
11	2	1/2" NPT Plug
12	1	1" NPT x 1/2" NPT Hex Bushing
13	1	1/2" NPT Oil Deflector
14	1	3/8" OD x 3/8" NPT Female Tubing Elbow
15	1	3/8" OD x 3/8" NPT Male Tubing Connector
16	1	3/8" NPT Tee
17	8	1/2 x 1-1/4" Hex Head Cap Screw
18	8	1/2" Heavy Hex Nut
19	4	1/2" Flat Washer
20	1	Gas Over Oil Tank (3 Gallon)
21	2	Angle
22	1	Plate
23	2	Spacer
24	As Req'd	3/8" OD Stainless Steel Tubing
25	As Req'd	1/2" OD Stainless Steel Tubing

- NOTES:**
- PC Apply Loctite pipe compound to pipe threads only
 - L Apply Loctite No. 262 to threads
 - TC Apply FEL-PRO "C-102" anti-seize compound to threads

ACTUATOR REPAIR, continued

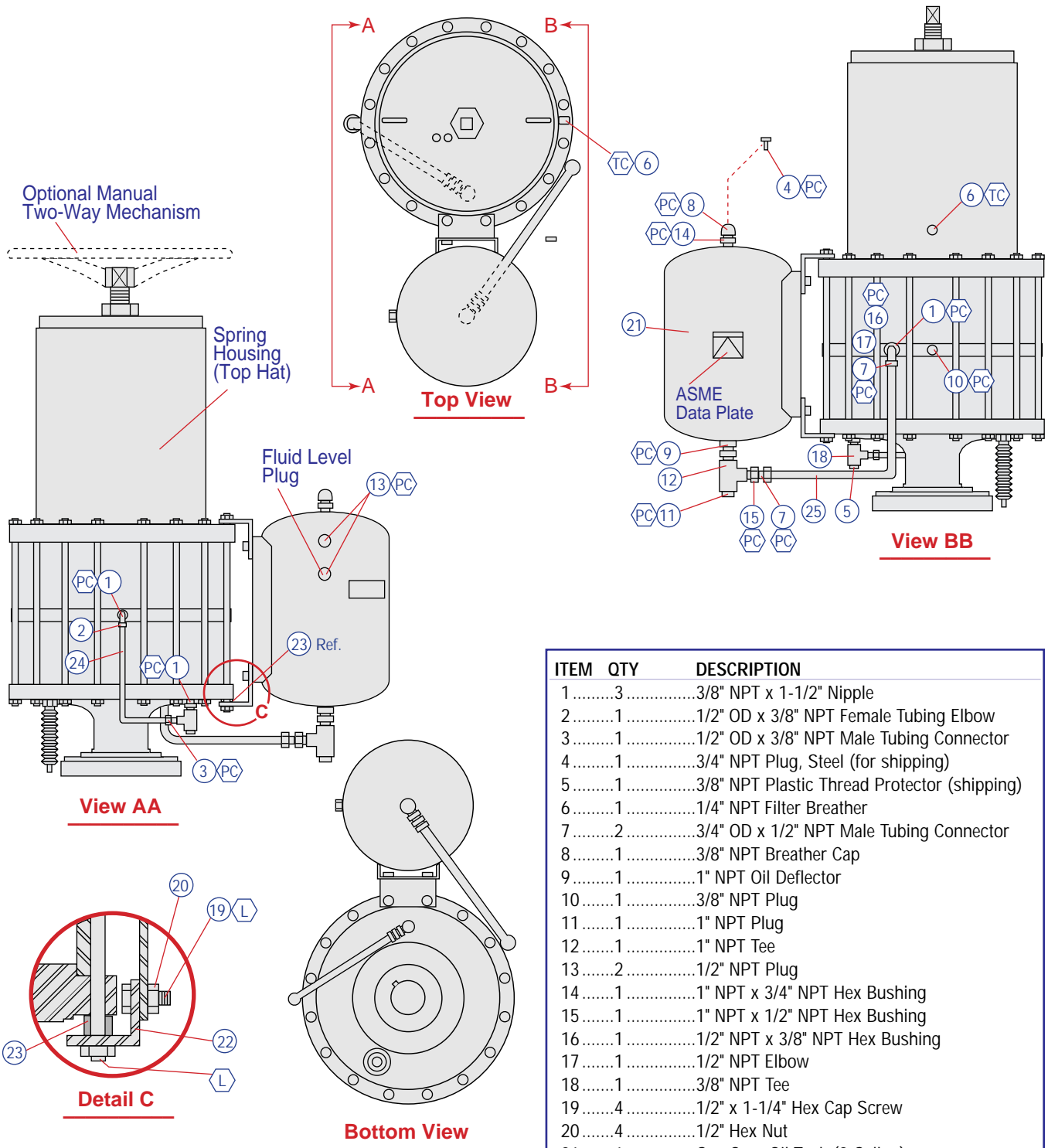

FIGURE 41
 "LS-185" Standard Gas/Oil
 Tank and Piping

ITEM	QTY	DESCRIPTION
1	3	3/8" NPT x 1-1/2" Nipple
2	1	1/2" OD x 3/8" NPT Female Tubing Elbow
3	1	1/2" OD x 3/8" NPT Male Tubing Connector
4	1	3/4" NPT Plug, Steel (for shipping)
5	1	3/8" NPT Plastic Thread Protector (shipping)
6	1	1/4" NPT Filter Breather
7	2	3/4" OD x 1/2" NPT Male Tubing Connector
8	1	3/8" NPT Breather Cap
9	1	1" NPT Oil Deflector
10	1	3/8" NPT Plug
11	1	1" NPT Plug
12	1	1" NPT Tee
13	2	1/2" NPT Plug
14	1	1" NPT x 3/4" NPT Hex Bushing
15	1	1" NPT x 1/2" NPT Hex Bushing
16	1	1/2" NPT x 3/8" NPT Hex Bushing
17	1	1/2" NPT Elbow
18	1	3/8" NPT Tee
19	4	1/2" x 1-1/4" Hex Cap Screw
20	4	1/2" Hex Nut
21	1	Gas-Over-Oil Tank (8 Gallon)
22	2	Angle
23	2	Spacer
24	As Req'd	1/2" OD Stainless Steel Tubing
25	As Req'd	3/4" OD Stainless Steel Tubing

NOTES: Apply Loctite pipe compound to pipe threads only
 Apply Loctite No. 262 to threads
 Apply FEL-PRO "C-102" anti-seize compound to threads

ACTUATOR REPAIR, continued

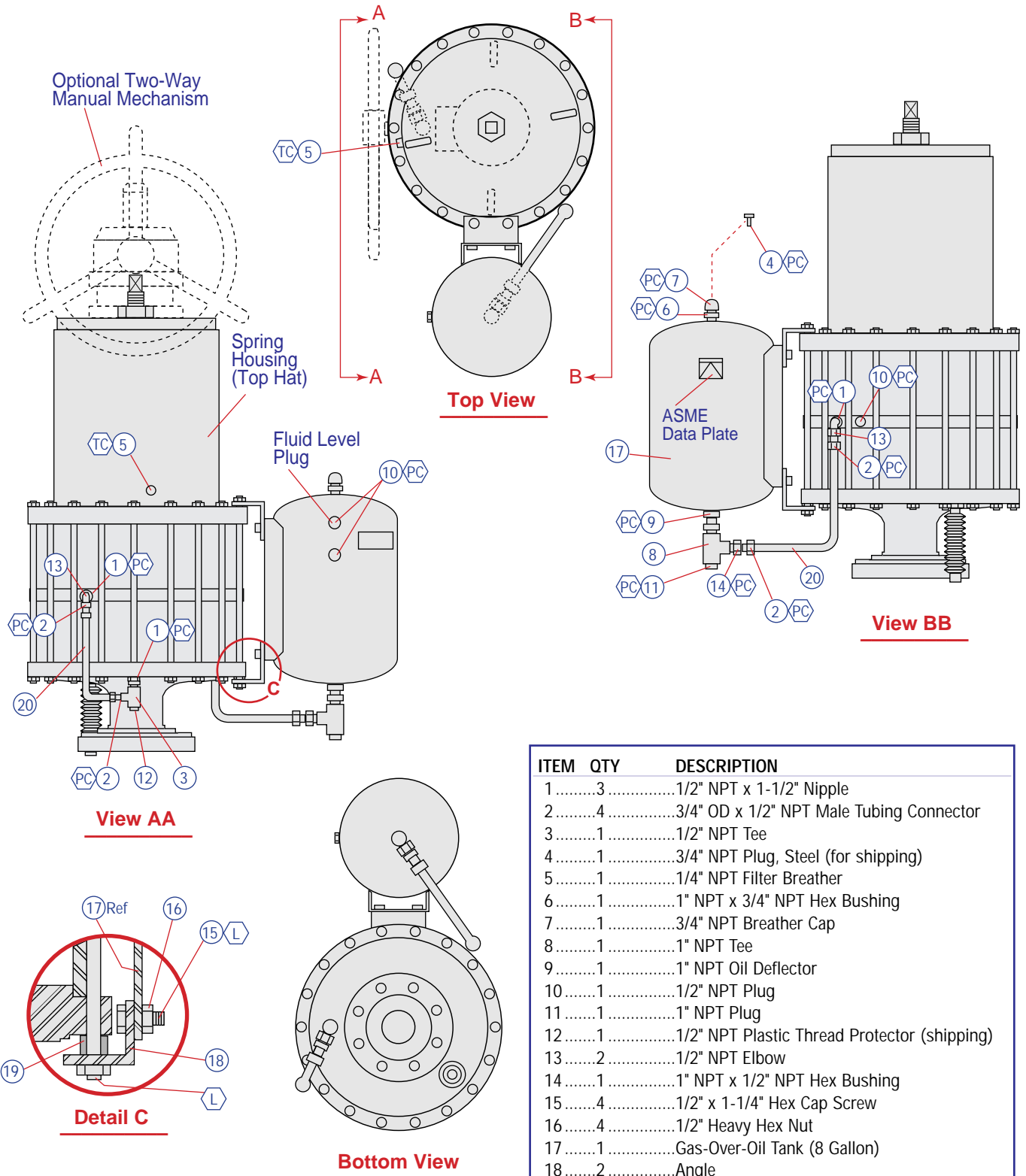

FIGURE 42
 "LS-205" Standard Gas/Oil
 Tank and Piping

ITEM	QTY	DESCRIPTION
1	3	1/2" NPT x 1-1/2" Nipple
2	4	3/4" OD x 1/2" NPT Male Tubing Connector
3	1	1/2" NPT Tee
4	1	3/4" NPT Plug, Steel (for shipping)
5	1	1/4" NPT Filter Breather
6	1	1" NPT x 3/4" NPT Hex Bushing
7	1	3/4" NPT Breather Cap
8	1	1" NPT Tee
9	1	1" NPT Oil Deflector
10	1	1/2" NPT Plug
11	1	1" NPT Plug
12	1	1/2" NPT Plastic Thread Protector (shipping)
13	2	1/2" NPT Elbow
14	1	1" NPT x 1/2" NPT Hex Bushing
15	4	1/2" x 1-1/4" Hex Cap Screw
16	4	1/2" Heavy Hex Nut
17	1	Gas-Over-Oil Tank (8 Gallon)
18	2	Angle
19	2	Spacer
20	As Req'd	3/4" OD Stainless Steel Tubing

- NOTES:**
- PC Apply Loctite pipe compound to pipe threads only
 - L Apply Loctite No. 262 to threads
 - TC Apply FEL-PRO "C-102" anti-seize compound to threads

ACTUATOR REPAIR, continued

DISASSEMBLY OF SPRING-CLOSE ACTUATOR (LS-124/185/205)

The following procedure describes the complete disassembly of the actuator. Orbit recommends removing the actuator from the valve for any internal repairs. However, some internal repairs may be done while the actuator is attached to the valve. Extra safety precautions must be observed to prevent the spring from unexpectedly expanding, causing personal injury and equipment damage. These precautions are: (to be done in order),

- a) Close valve. (Note: The valve may tend to open due to pressure in the valve body as the spring compression is released or as the actuator is removed.)
- b) Be sure the gas (air) pressure to the actuator has been reduced to atmospheric and is maintained there. (Note: It is recommended that the pressure supply line be disconnected.)
- c) Loosen the jam nut and turn the spring adjusting screw counterclockwise ↺ until it turns freely or the dimension shown in Figure 43 below is reached. (Note: On LS-124 models, the screw may come loose from the spring case.)
- d) Refer to Figure 43. Remove four (4) studs and install new, longer all-thread studs with nuts, (3 inches (76 mm) minimum longer than existing studs.) Remove the remaining shorter studs. Evenly loosen the nuts on the new longer studs so any remaining spring compression will be released.

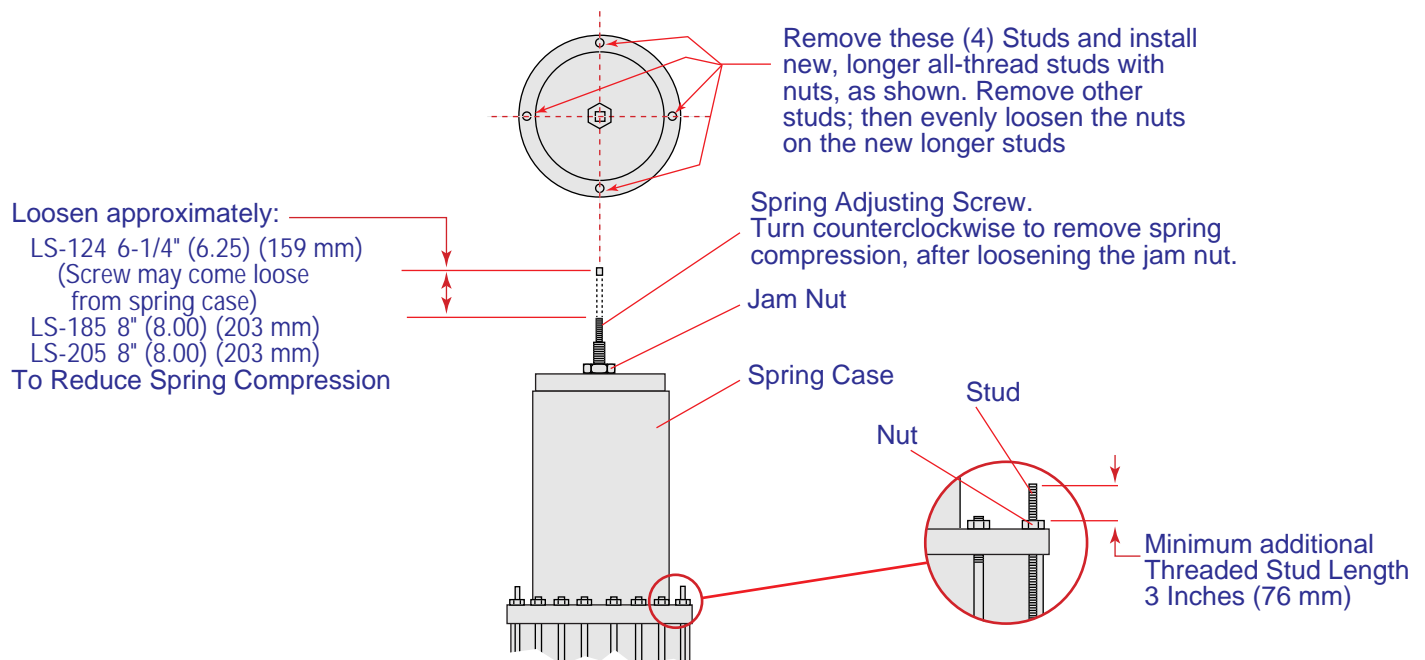

FIGURE 43

Removing Spring Case When Actuator is Attached to the Valve.

ACTUATOR REPAIR, continued

Refer to Figure 44 for disassembly of the actuator.

1. Mark the orientation of the actuator upper, middle & lower heads and the upper & lower cylinders using an arrow "↑" with something that will not rub off (such as paint, marking pen, etc.) Also, mark the upper & lower cylinders with the words, "Upper" and "Lower". This will greatly aid in reassembly later. See the illustration at right.

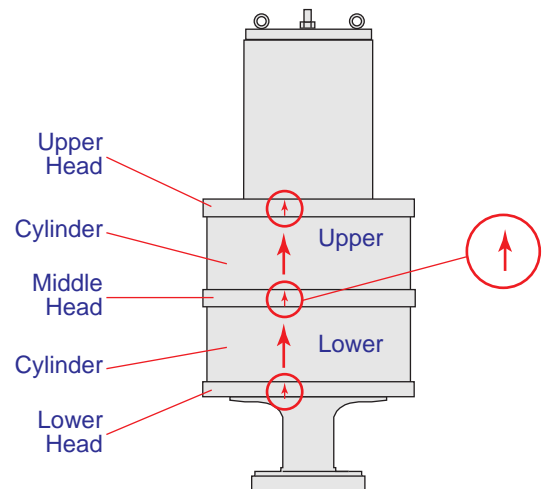

2. Remove the pointer clamp, hose clamp, and rod boot (Items 1, 2, & 3).
3. Loosen the set screws (Item 4) and remove the collar (Item 5). Remove any burrs on the VPI rod (Item 8) with fine emery cloth. Remove the VPI rod bushing (Item 6), and then the O-ring (Item 7).
4. Securely bolt or clamp the actuator to a clean work bench. (Note: This will be necessary to restrain the actuator while loosening the highly torqued piston rod nut (Item 23) in Step 9.)
5. Remove the studs and nuts (Item 9 & 10) and lift off the upper cylinder head (spring case) (Item 12).
6. LS-124 Actuator Only. Remove the jam nut (Item 14). Turn the spring adjusting screw (Item 13) counterclockwise ↺ and remove it from the upper cylinder head (Item 12). Remove the spring loading plate (Item 15).

LS-185 & LS-205 Actuators (see Detail "A"). Lay the upper cylinder head (spring case) (Item 12) on its side. Turn the spring adjusting screw (Item 13) clockwise ↻ until it comes loose from the upper cylinder head. Tilt the upper cylinder head so the spring adjusting screw and the spring loading plate (Items 13 & 15) slide out. Remove the retaining ring, spring loading plate, bearing and bearing collar (Items 16, 15, 17, & 18) from the spring adjusting screw. (Note: Locknut (Item 19) will remain on the spring adjusting screw.)

7. Lift the spring (Item 20) off the upper piston (Item 21).
8. Lift the upper cylinder (Item 25) off the actuator. (Note: Be careful not to damage the inside surface of the cylinder.)
9. Remove the piston rod nut and the spring positioning ring (Item 23 & 24). (Note: See detail "D" for LS-205 model actuator.)
10. Remove the upper piston (Item 21). (Note: Two tapped holes are provided for lifting.) Remove the upper piston seal (Item 26 - Detail "B").

ACTUATOR REPAIR, continued

11. Lift the middle cylinder head off and remove the piston rod sleeve (Items 27 & 28). (Note: If the middle cylinder head and sleeve come off together, separate them after removal from the actuator. Two tapped holes in the middle cylinder head are provided for lifting. The pipe and tubing fittings may remain in place unless damaged.) Remove the O-rings (Items 29, 30 & 44).
12. Remove the lower piston with the VPI rod assembly (Items 31 & 8). Remove the lower cylinder (Item 32). Remove the lower piston seal (Item 26 - see detail "B") and the cylinder O-ring (Item 29 - see detail "C"). Unscrew the VPI rod from the lower piston.

NOTES:

- (a) Two tapped holes in the lower piston are provided for lifting.
 - (b) Be careful not to damage the inside surface of the cylinder.
 - (c) If the lower piston and the lower cylinder come off together, separate them after removing from the actuator.
 - (d) The VPI rod may require heating with a propane torch to 350°F (177°C) for a few minutes to degrade the Loctite on the threads.
13. Remove the retaining ring (Item 33).
 14. Using the piston rod (Item 22), pop out the sealing gland (Item 34). Slide the sealing gland over the top of the piston rod. Remove the inner and outer O-rings (Items 35 & 36), then remove the key (Item 37).
 15. Remove, only if damaged, the lifting lugs and the filter/ breather (Items 38 & 39) from the upper cylinder head (spring case).
 16. Remove, only if damaged, the lube (and relief) fitting (Item 41) from the lower cylinder head (Item 40). (Note: Pipe and tubing fittings may remain in the lower cylinder head, unless damaged.)
 17. Remove two (2) drive screws and nameplate (Items 42 & 43) only if (a) damaged, (b) replacing middle cylinder head, or (c) making changes to the nameplate. See detail "E".
 18. Clean and inspect parts. (Note: Orbit recommends replacing all O-rings and seals, any time an actuator is disassembled, to prevent future unscheduled repairs because of an O-ring that appeared good.)

ACTUATOR REPAIR, continued

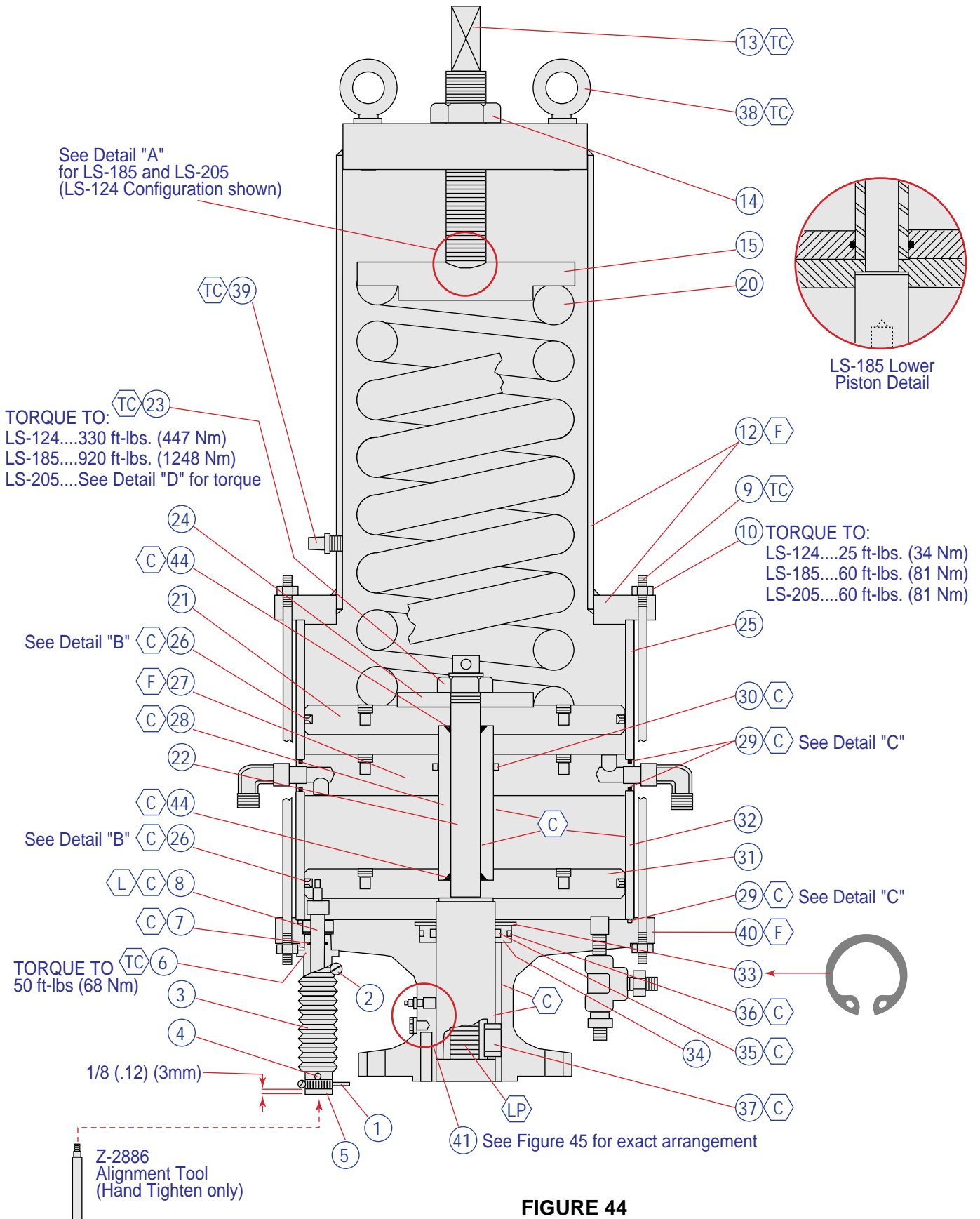

FIGURE 44
 Spring Close Actuator - Disassembly / Assembly

ACTUATOR REPAIR, continued

- | | | |
|---|---|---|
| <ol style="list-style-type: none"> 1. POINTER CLAMP 2. HOSE CLAMP 3. ROD BOOT 4. SET SCREW (2 REQ'D) (1/4-20) 5. COLLAR 6. VPI ROD BUSHING 7. O-RING (1/2" x 11/16" x 3/32") 8. VPI ROD ASSEMBLY 9. STUDS 10. NUTS 11. ----- 12. UPPER HEAD (SPRING CASE) 13. SPRING ADJUSTING SCREW 14. JAM NUT 15. SPRING LOADING PLATE 16. RETAINING RING 17. BEARING 18. BEARING COLLAR 19. LOCK NUT 20. SPRING | <ol style="list-style-type: none"> 21. UPPER PISTON 22. PISTON ROD 23. PISTON ROD NUT 24. SPRING POSITIONING RING 25. UPPER CYLINDER 26. PISTON SEAL (SEE DETAIL "B") 27. MIDDLE CYLINDER HEAD 28. PISTON ROD SLEEVE 29. O-RING
LS-124 (12-1/4" x 12-1/2" x 1/8")
LS-185 (17-9/16" x 17-13/16" x 1/8")
LS-205 (19-3/16" x 19-7/16" x 1/8") 30. O-RING
LS-124 (2-1/8" x 2-1/2" x 3/16")
LS-185 (2-1/2" x 2-7/8" x 3/16")
LS-205 (3" x 3-3/8" x 3/16") 31. LOWER PISTON 32. LOWER CYLINDER 33. RETAINING RING 34. SEALING GLAND | <ol style="list-style-type: none"> 35. O-RING
LS-124 (2-1/8" x 2-1/2" x 3/16")
LS-185 (2-1/2" x 2-7/8" x 3/16")
LS-205 (3" x 3-3/8" x 3/16") 36. O-RING
LS-124 (3-1/8" x 3-3/8" x 1/8")
LS-185 (3-1/8" x 3-7/8" x 1/8")
LS-205 (4-1/8" x 4-3/8" x 1/8") 37. FLAT KEY 38. LIFTING LUGS 39. FILTER/BREATHER 40. LOWER CYLINDER HEAD 41. LUBE/RELIEF FITTING(S) 42. DRIVE SCREW (2 REQ'D) 43. NAMEPLATE 44. O-RING
LS-124 (1-1/8" x 1-3/8" x 1/8")
LS-185 (1-5/8" x 1-7/8" x 1/8")
LS-205 (2-1/4" x 2-1/2" x 1/8") |
|---|---|---|

- NOTES:**
- Ⓢ Coat with Lubriplate LM-123-006 grease
 - Ⓛ Apply Loctite No. 262 to threads
 - ⓉⓈ Apply FEL-PRO "C-102" anti-seize lubricant to threads
 - ⓁⓉ Apply or pack with Lubriplate "Low Temp" lubricant.
 - Ⓢ Refer to Figure 46 for proper head stacking orientation.

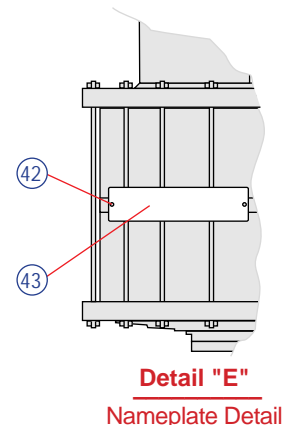
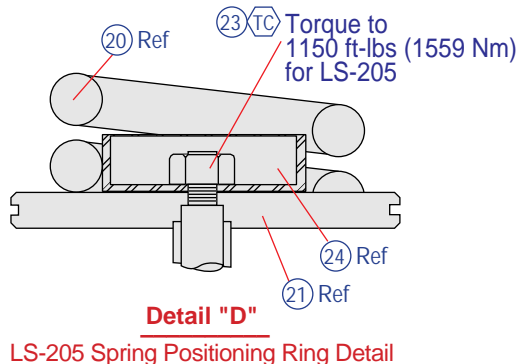
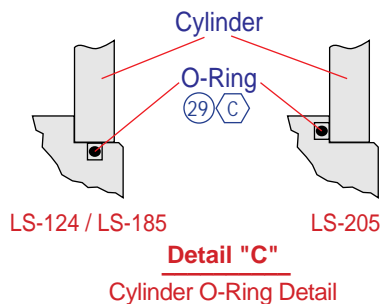
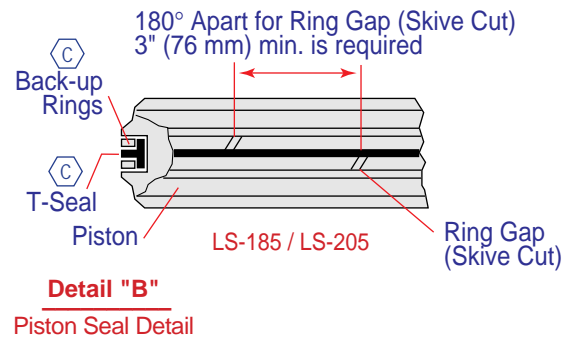
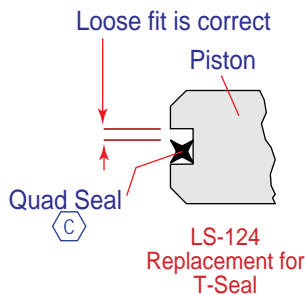
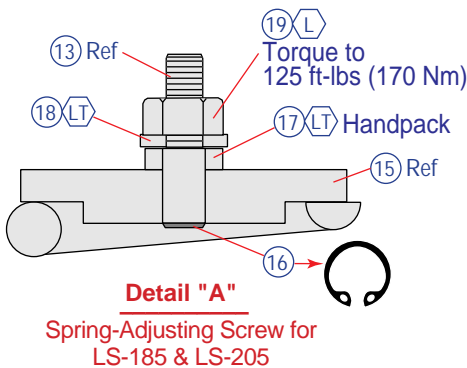

FIGURE 44, Continued

ACTUATOR REPAIR, continued

ASSEMBLY OF SPRING-CLOSE ACTUATOR (LS-124/185/205)

Refer to Figure 44 for assembly of the actuator. (Lubricate at the points noted in the figure during assembly.)

1. If removed, attach the nameplate (Item 43) with two (2) drive screws (Item 42). (See detail "E".)
2. Install the lube/relief fittings (Item 41) if they were removed or missing. See Figure 45 below for exact arrangement of fittings. (Note: Failure to install the lube and relief fittings in the proper hole could cause the valve/ actuator to lock-up.)

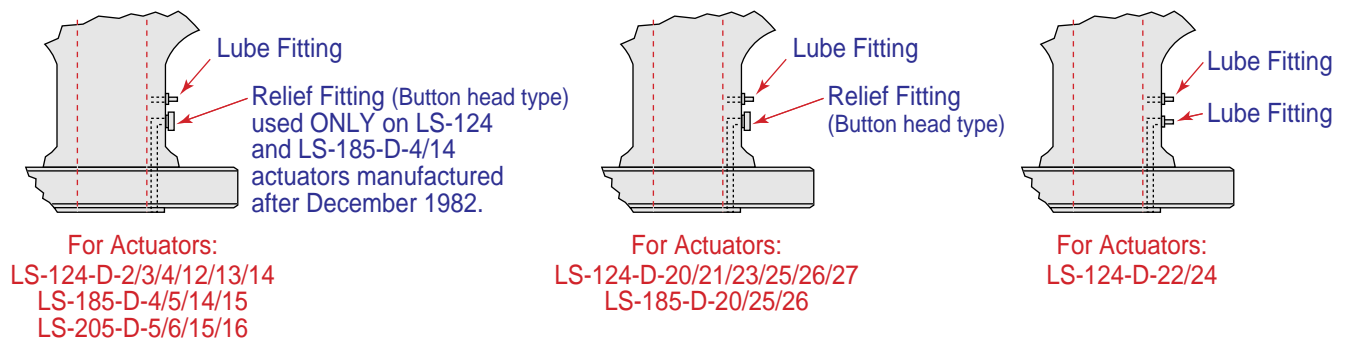

FIGURE 45
Lube / Relief Fitting Arrangement

3. If removed, install the lifting lugs and the filter/breather (Items 38 & 39).
4. Securely bolt or clamp the lower cylinder head (Item 40) to a clean work bench. This will be necessary later in the assembly, to restrain the actuator while tightening the highly torqued piston rod nut (Item 23).
5. Install the flat key (Item 37) into the piston rod (Item 22). Slide the piston rod and flat key into the lower cylinder head (Item 40).
6. Install the inner and outer O-rings (Items 35 & 36) on the sealing gland (Item 34). Slip the sealing gland with O-rings over the piston rod (Item 22) and into the recess in the lower cylinder head (Item 40). (Note: It may be necessary to tap it into place using a soft face hammer and block of wood.) Install the retaining ring (Item 33) in the ring groove in the lower cylinder head. (Note: check that the ring fully seats into the ring groove.)
7. Screw alignment tool Z-2886 hand tight into the threaded hole in the lower piston (Item 31). Install the piston seal (Item 26 - see detail "B") on the lower piston. Install the piston so that the alignment tool drops through the hole for the VPI rod bushing (Item 6). (Note: Two tapped holes are provided in the top of the piston, for lifting.)
8. Install the lower cylinder head O-ring (Item 29 - see detail "C") on the lower cylinder head (Item 40). Install the lower cylinder (Item 32). (Note: Match up the alignment marks "↑" on the cylinder and the lower cylinder head if they were marked at disassembly. Be careful not to damage the inside surface of the lower cylinder.)

ACTUATOR REPAIR, continued

9. Install the lower piston rod sleeve O-ring (Item 44) and install the piston rod sleeve (Item 28).
 10. Install O-rings (Items 29 & 30) on middle cylinder head (Item 27). Install the middle cylinder head with the two tapped holes up, (which are provided for lifting). Align the marks “↑” with the lower cylinder (Item 32) and the lower cylinder head (Item 40) if they were marked at disassembly. (Note: If they were not marked, align as shown in Figure 46.)
 11. Install the upper piston rod O-ring (Item 44). Install the piston seal (Item 26 - see detail “B”) on the upper piston (Item 21). Install the upper piston with the two tapped holes up, (provided for lifting).
 12. Install the spring positioning ring (Item 24). Install and torque the piston rod nut (Item 23). (LS-124=330 ft-lbs (447 Nm); LS-185=920 ft-lbs (1248 Nm); LS-205=1150 ft-lbs (1559 Nm)).
 13. Push down on the upper piston (Item 21) and close the actuator, if not already fully down.
 14. Install the upper cylinder (Item 25). (Note: Match up the alignment marks “↑” with the middle cylinder head (Item 27) if they were marked at disassembly. Be careful not to damage the inside surface of the upper cylinder.)
 15. Install the spring (Item 20).
 16. LS- 124 Actuator Only
 - (a) Install the spring loading plate (Item 15) onto the spring.
 - (b) Screw the spring adjusting screw (Item 13) clockwise ☻ (when looking from the top) into the upper cylinder head (Item 12) about one inch (25 mm)
- LS-185 & LS-205 Actuators (see detail “A”)
- (a) If removed, install the lock nut (Item 19) onto the spring adjusting screw (Item 13).
 - (b) Thread the spring adjusting screw (Item 13) into the upper cylinder head (spring housing) (Item 12).
 - (c) Lay the upper cylinder head on its side and install the bearing collar, bearing, spring loading plate, and retaining ring (Items 18, 17, 15, & 16) onto the spring adjusting screw (Item 13).
 - (d) Turn the spring adjusting screw counterclockwise ☹ until the spring loading plate contacts the top of the upper cylinder head (spring housing).
17. Install the jam nut (Item 14) finger tight. (Note: It will be tightened after the spring is adjusted.)
 18. Install the upper cylinder head (spring case) (Item 12) and align the marks “↑” with the middle and lower cylinder heads. (Note: If they were not marked at disassembly, align as shown in Figure 46.) (Note: If the upper cylinder head does not seat fully due to the spring, install four all-thread studs and nuts that are approximately three inches (75 mm) longer than the regular studs (Item 9). Evenly tighten these down to compress the spring until the rest of the regular studs can be installed. Then, remove the longer studs and install the regular studs and nuts. Refer to Figure 43.

ACTUATOR REPAIR, continued

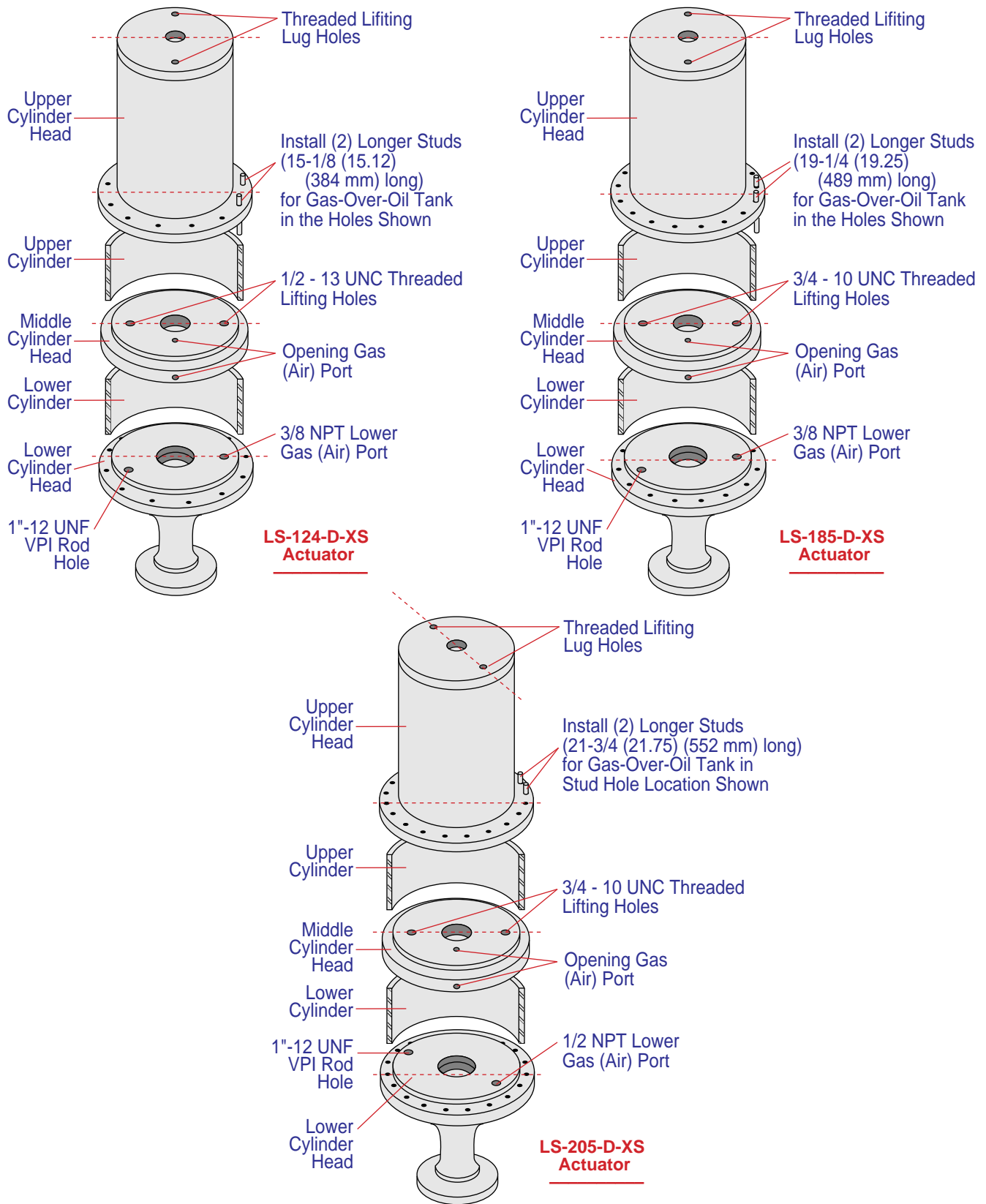

FIGURE 46
Cylinder Head Stacking (Alignment)

ACTUATOR REPAIR, continued

19. Install the studs and nuts (Items 9 & 10) using a criss-cross pattern to tighten. (Note: There are two longer studs and these should be installed as shown in Figure 46 for the gas-over-oil tank.)
20. Remove the alignment tool Z-2886 and install the VPI rod assembly (Item 8) using the slot in the end of the rod to tighten. (Note: Remove all burrs on the rod with fine emery cloth.)
21. Install the O-ring (Item 7) into the VPI rod bushing (Item 6). Slip the bushing onto the VPI rod assembly (Item 8) and tighten securely into the lower cylinder head.
22. Slip the hose clamp (Item 2) over one end of the rod boot (Item 3) and the pointer clamp (Item 1) over the other end. Install and tighten the hose clamp and rod boot over the VPI rod bushing (Item 6).
23. Install the collar (Item 5) onto the end of the VPI rod assembly (Item 8) with the set screws (Item 4). Slip the rod boot (Item 3) over the collar so that it is about even with the bottom of the collar, and the bottom of the pointer clamp (Item 1) is 1/8 (.12) inch (3 mm) from the bottom of the collar. Then tighten the pointer clamp.
24. Install the gas-over-oil tank as described on page 59. The actuator is now ready to mount to a valve. (See page 11 for the various mounting procedures.)

ACTUATOR REPAIR, continued

DISASSEMBLY OF SPRING-CLOSE ACTUATOR WITH TWO-WAY MECHANISM (LS-124 & LS185)

The following procedure describes a complete disassembly of the actuator. Orbit recommends removing the actuator from the valve for any internal repairs. However, some internal repairs may be done while the actuator is attached to the valve. Extra safety precautions must be observed to prevent the spring from unexpectedly expanding, causing personal injury and equipment damage. These precautions are; (to be done in order),

- a) Close valve. (Note: The valve may tend to open due to pressure in the valve body as the spring compression is released or as the actuator is removed.)
- b) Be sure the gas (air) pressure to the actuator has been reduced to atmospheric and is maintained there. (Note: It is recommended that the pressure supply line be disconnected.)

(TYPE-M-) (LS-124 & LS-185)

- c) Loosen the jam nut and turn the handwheel counterclockwise ↺ until it turns freely or until the dimension shown in Figure 47 below is reached.

(TYPE-N-) (LS-124 & LS-185)

- c) Remove the lock pin and turn the handwheel counterclockwise ↺ until it turns freely or until the dimension shown in Figure 47 below is reached.
- d) Refer to Figure 47. Remove four (4) studs and install new, longer all-thread studs and nuts (3 inches (76 mm) minimum longer than existing studs). Remove the remaining shorter studs. Evenly loosen the nuts on the new longer studs so any remaining spring compression will be released.

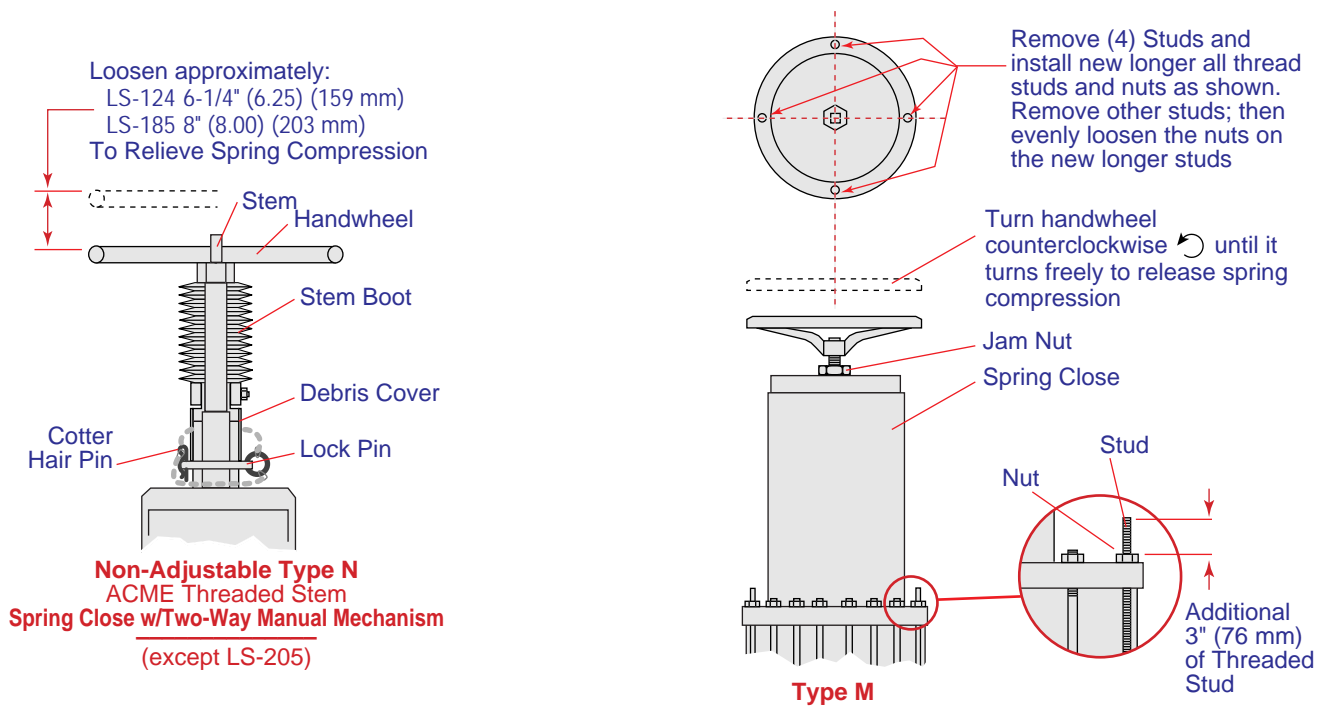

ACTUATOR REPAIR, continued

Refer to Figure 48 for disassembly of the actuator.

1. Mark the orientation of the actuator upper, middle & lower heads and the upper & lower cylinders, using an arrow "↑", with something that will not rub off (such as paint, marking pen, etc.). Also, mark the upper & lower cylinders with the words, "Upper" and "Lower". This will greatly aid in reassembly later. See illustration at right.
2. Remove the pointer clamp, hose clamp, and rod boot (Items 1, 2, & 3).
3. Loosen the set screws (Item 4) and remove the collar (Item 5). Remove any burrs on the VPI rod (Item 8) with fine emery cloth. Remove the VPI rod bushing (Item 6), and then the O-ring (Item 7).
4. Securely bolt or clamp the actuator to a clean work bench. (Note: This will be necessary to restrain the actuator while loosening the highly torqued piston rod nut (Item 32) later in the disassembly.)

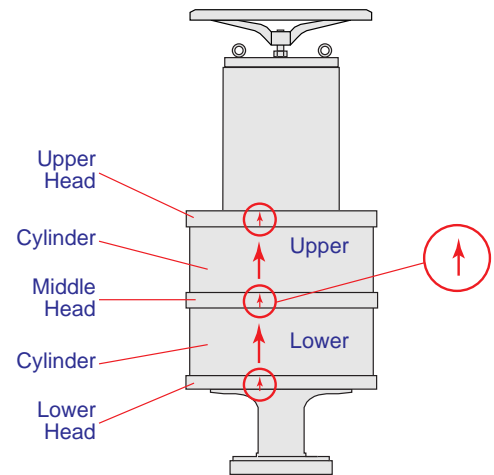

(Type -M-) (LS-124 & LS-185)

5. Remove the cotter pin, handwheel, and the jam nut (Items 9, 10 & 11) (Fig. 48).

(TYPE -N-) (LS-124 & LS-185)

5. Remove the cotter pin, handwheel, hose clamps, stem boot, and collar (Items 9, 10, 53, 56 and 55) (Fig. 48a).
6. Remove the studs and nuts (Items 12 & 13).
7. Lift the upper head (spring case) (Item 14) until it clears the upper cylinder (Item 15). Then, turn the upper head counterclockwise ↺ (when viewed from the top) while holding the manual operator stem (Item 16), until the threaded portion of the stem disengages the upper head or stem nut. Do not remove the stem nut (Item 62) or debris cover (Item 59) from upper head. Lift off upper head.
8. Remove, only if damaged, the lifting lugs (Item 17), the folding spring position gage (Item 18 - Detail "A"), and the filter/breather (Item 19).
9. **LS-124 Actuator Only**
 - a. Remove the retaining ring (Item 20) with spanner wrenches.
 - b. Remove the spring (Item 21) and upper cylinder (item 15). (Note: Be careful not to damage the inside surface of the cylinder.)
 - c. Remove the cap screws (Item 22).
 - d. Lift off the manual operator stem (Item 16) with the bearing housing (Item 23) and all items attached to it.
 - e. Remove the nut, lower bearing collar, and lower bearing (Items 24, 25 & 26). Then remove the bearing housing (Item 23) from the stem.
 - f. Remove the hub (Item 27). Then remove the upper bearing and upper collar (Items 28 & 29) from the stem.

LS-185 Actuator Only (see Detail "B")

- a. Remove the jam nut, upper bearing collar, and upper bearing (Items 30, 29 & 28).
- b. Lift off the spring loading plate (Item 31), the spring (Item 21), and the upper cylinder (Item 15). (Note: Be careful not to damage the inside surface of the cylinder.)
- c. Remove the cap screws (Item 22).

ACTUATOR REPAIR, continued

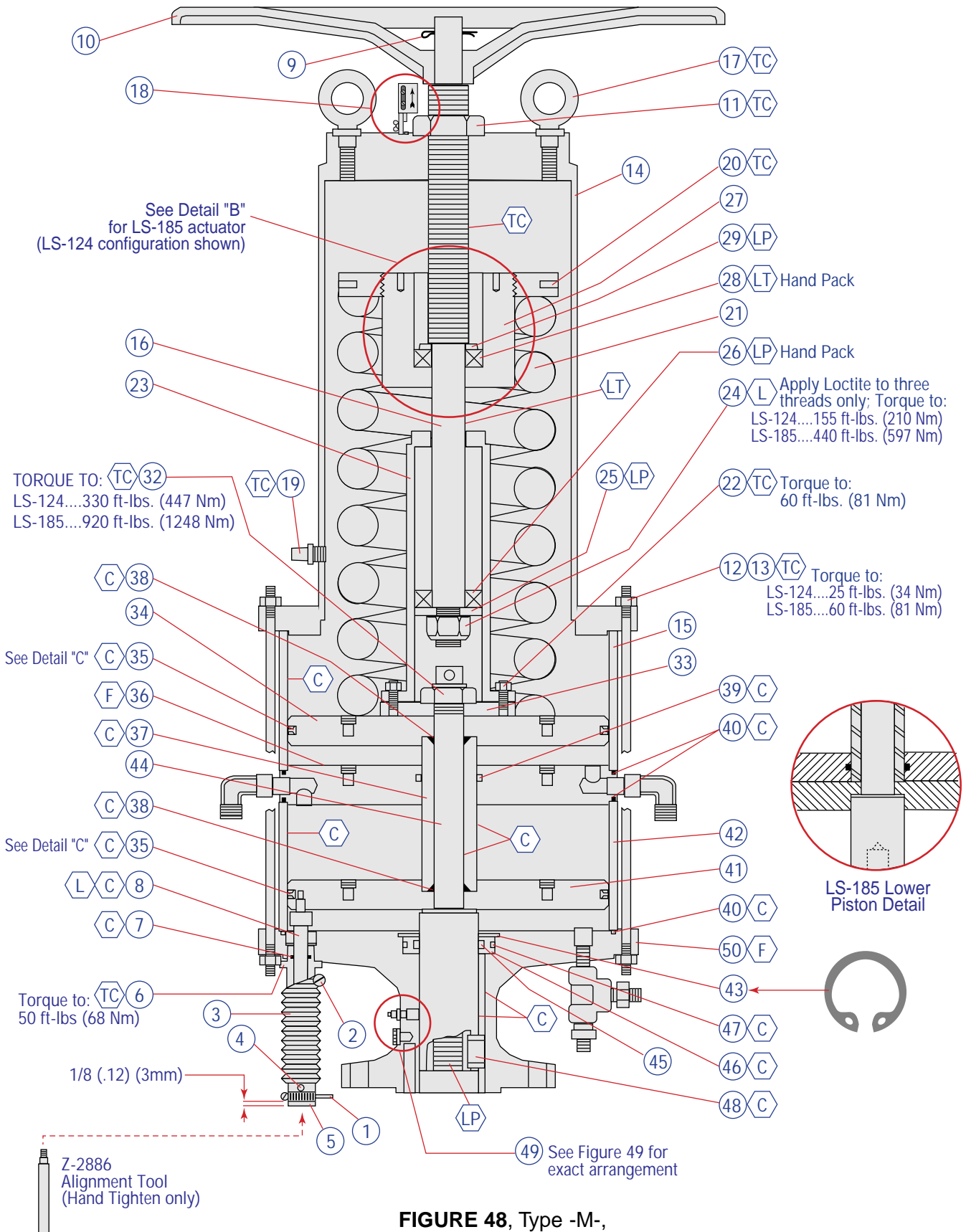

**FIGURE 48, Type -M-,
 LS-124/LS-185 Spring Close with Two-Way Mechanism - Disassembly/Assembly**

ACTUATOR REPAIR, continued

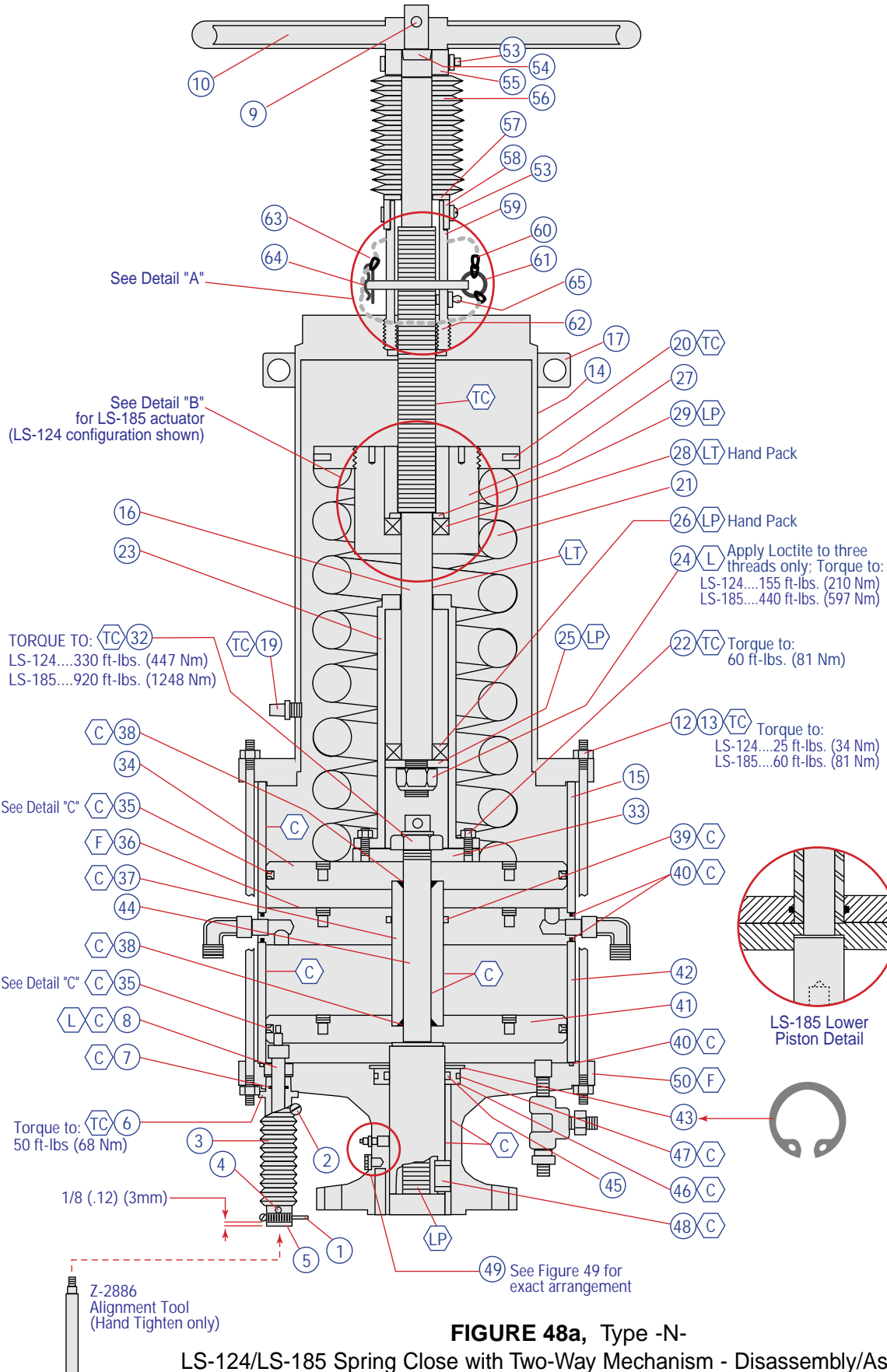

ACTUATOR REPAIR, continued

- | | | |
|---|--|---|
| <ol style="list-style-type: none"> 1. POINTER CLAMP 2. HOSE CLAMP 3. ROD BOOT 4. SET SCREW (2 REQ'D)(1/4-20) 5. COLLAR 6. VPI ROD BUSHING 7. O-RING (1/2 x 11/16 x 3/32) 8. VPI ROD ASSY 9. COTTER PIN 10. HANDWHEEL 11. JAM NUT 12. STUDS 13. NUTS 14. UPPER HEAD (SPRING CLOSE) 15. UPPER CYLINDER 16. MANUAL OPERATOR STEM 17. LIFTING LUGS 18. SPRING POSITION GAGE 19. FILTER/BREATHER 20. RETAINING RING 21. SPRING 22. CAPSCREWS 23. BEARING HOUSING 24. NUT 25. LOWER BEARING COLLAR | <ol style="list-style-type: none"> 26. LOWER BEARING 27. HUB 28. UPPER BEARING 29. UPPER BEARING COLLAR 30. JAM NUT 31. SPRING LOADING PLATE 32. PISTON ROD NUT 33. SPRING POSITIONING RING 34. UPPER PISTON 35. PISTON SEAL (SEE DETAIL "C") 36. MIDDLE CYLINDER HEAD 37. PISTON ROD SLEEVE 38. O-RING (2 REQ'D)
LS-124 (1-1/8 x 1-3/8 x 1/8)
LS-185 (1-5/8 x 1-7/8 x 1/8) 39. O-RING
LS-124 (2-1/8 x 2-1/2 x 3/16)
LS-185 (2-1/2 x 2-7/8 x 3/16) 40. O-RING (3 REQ'D)
LS-124 (12-1/4 x 12-1/2 x 1/8)
LS-185 (17-9/16 x 17-13/16 x 1/8) 41. LOWER PISTON 42. LOWER CYLINDER 43. RETAINING RING 44. PISTON ROD | <ol style="list-style-type: none"> 45. SEALING GLAND 46. O-RING (INNER)
LS-124 (2-1/8 x 2-1/2 x 3/16)
LS-185 (2-1/2 x 2-7/8 x 3/16) 47. O-RING (OUTER)
LS-124 (3-1/8 x 3-3/8 x 1/8)
LS-185 (3-5/8 x 3-7/8 x 1/8) 48. KEY 49. LUBE RELIEF FITTING(S) 50. LOWER CYLINDER HEAD 51. DRIVE SCREWS (2 REQ'D) 52. NAMEPLATE 53. HOSE CLAMP 54. O-RING 55. COLLAR 56. STEM BOOT 57. RETAINING RING 58. COLLAR 59. DEBRIS COVER (DO NOT REMOVE) 60. CHAIN-LOCK PIN 61. SPLIT RING-LOCK PIN 62. STEM NUT (DO NOT REMOVE) 63. COTTER HAIR PIN 64. LOCK PIN 65. LUBE FITTING |
|---|--|---|

- NOTES:**
- Ⓒ Coat with Lubriplate LM-123-006 grease
 - Ⓓ Apply Loctite No. 262 to thread
 - ⒸⒹ Apply FEL-PRO "C-102" anti-seize lubricant to threads
 - ⒹⒻ Apply or pack with Lubriplate "930-AA" lubricant.
 - Ⓔ Refer to Figure 50 for proper head stacking orientation.

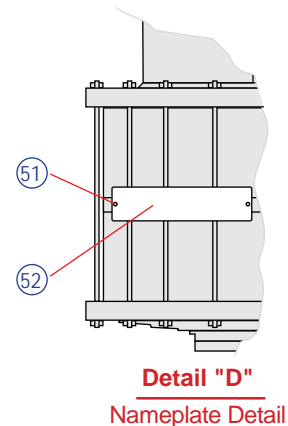
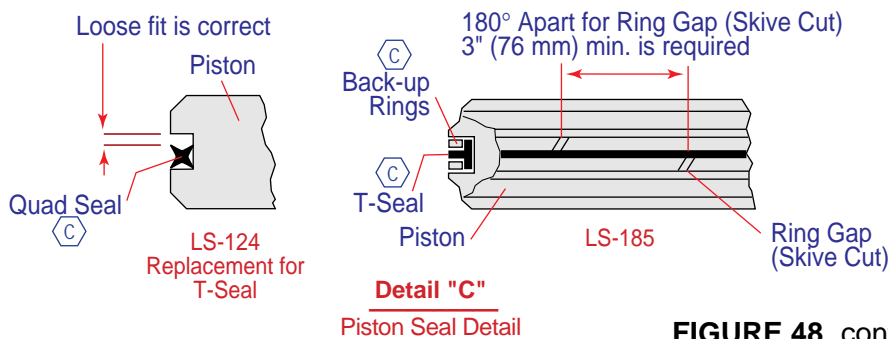
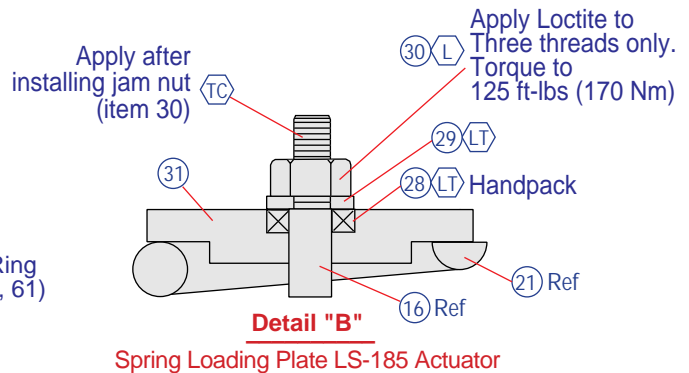
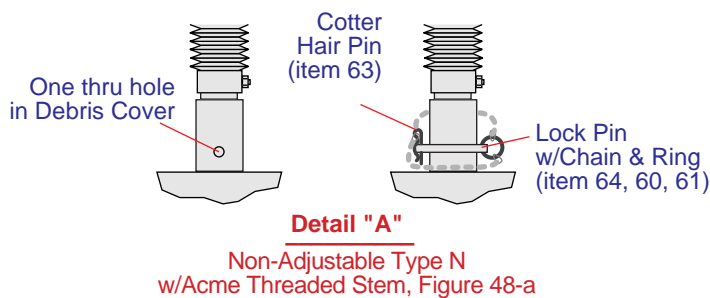
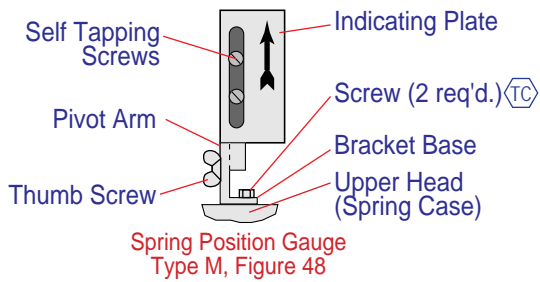

FIGURE 48, continued

ACTUATOR REPAIR, continued

- d. Lift off the manual operator stem (Item 16) with the bearing housing (Item 23) and all items attached to it.
 - e. Remove the stem (Item 16) from the bearing housing (Item 23).
 - f. Remove the nut, lower bearing collar and lower bearing (Item 24, 25 & 26).
10. Remove the piston rod nut (Item 32) and spring positioning ring (Item 33).
 11. Remove the upper piston (Item 34). (Note: Two tapped holes are provided for lifting.) Remove the upper piston seal (Item 35 - see Detail "C").
 12. Lift off the middle cylinder head and remove the piston rod sleeve (Items 36 & 37). (Note: If the middle cylinder head and sleeve come off together, separate them after removal from the actuator. Two tapped holes in the middle cylinder head are provided for lifting. The pipe and tubing fittings may remain in place unless damaged.) Remove the O-rings (Items 38, 39 & 40).
 13. Remove the lower piston with the VPI rod assembly (Items 41 & 8). Remove the lower cylinder (Item 42). Remove the lower piston seal (Item 35 see detail "C") and the cylinder O-ring (Item 40). Unscrew the VPI rod from the lower piston.

NOTES:

- (a) Two tapped holes in the lower piston are provided for lifting.
 - (b) Be careful not to damage the inside surface of the cylinder.
 - (c) If the lower piston and the lower cylinder come off together, separate them after removing from the actuator.
 - (d) The VPI rod may require heating with a propane torch to 350°F (177°C) for a few minutes to degrade the Loctite on the threads.
14. Remove the retaining ring (Item 43).
 15. Pulling quickly upwards on the piston rod (Item 44), pop out the sealing gland (Item 45). Slide the sealing gland over the top of the piston rod. Remove the inner and outer O-rings (Items 46 & 47), then remove the key (Item 48).
 16. Remove, only if damaged, the lifting lugs and the filter/breather (Items 17 & 19) from the upper cylinder head (spring case).
 17. Remove, only if damaged, the lube and relief fitting (Item 49) from the lower cylinder head (Item 50). (Note: Pipe and tubing fittings may remain in the lower cylinder head unless damaged.)
 18. Remove two (2) drive screws and nameplate (Items 51 & 52) only if
 - (a) damaged,
 - (b) replacing middle cylinder head, or
 - (c) making changes to the nameplate. See detail "D".
 19. Clean and inspect parts. (Note: Orbit recommends replacing all O-rings and seals any time an actuator is disassembled, to prevent future unscheduled repairs because of an O-ring that appeared good.)

ACTUATOR REPAIR, continued

ASSEMBLY OF SPRING CLOSE ACTUATOR WITH TWO-WAY MECHANISM (LS-124 and LS-185)

Refer to figures 48 and 48a for assembly of the actuator. (Lubricate at the points noted in the figure during assembly.)

1. If removed, attach the nameplate (Item 52) with two (2) drive screws (Item 51). (See detail "D".)
2. Install the lube/relief fittings (Item 49) if they were removed or missing. See Figure 49 below for exact arrangement of fittings. (Note: Failure to install the lube and relief fittings in the proper hole could cause the valve/actuator to lock-up.)

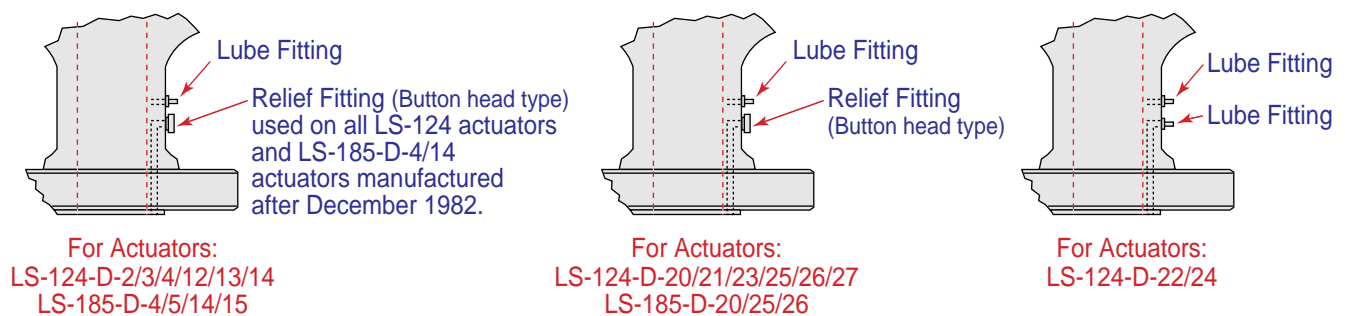

FIGURE 49
Lube/Relief Fitting Arrangement

3. If removed, install the lifting lugs and the filter/breather (Items 17 & 19).
4. Securely bolt or clamp the lower cylinder head (Item 50) to a clean work bench. This will be necessary later in the assembly to restrain the actuator while tightening the highly torqued piston rod nut (Item 32).
5. Install the flat key (Item 48) into the piston rod (Item 44). Slide the piston rod and flat key into the lower cylinder head (Item 50).
6. Install the inner and outer O-rings (Items 46 & 47) on the sealing gland (Item 45). Slip the sealing gland with O-rings over the piston rod (Item 44) and into the recess in the lower cylinder head (Item 50). (Note: It may be necessary to tap it into place using a soft face hammer and block of wood.) Install the retaining ring (Item 43) in the ring groove in the lower cylinder head. (Note: Check carefully that the ring fully seats into the ring groove.)
7. Screw the alignment tool Z-2886 hand tight into the threaded hole in the lower piston (Item 41). Install the piston seal (Item 35 - see detail "C") on the lower piston. Install the piston so that the alignment tool drops through the hole for the VPI rod bushing (Item 6). (Note: Two tapped holes are provided in the top of the piston for lifting.)
8. Install the lower cylinder head O-ring (Item 40) on the lower cylinder head (Item 50). Install the lower cylinder (Item 42). (Note: Match up the alignment marks "↑" on the cylinder and the lower cylinder head if they were marked at disassembly. Be careful not to damage the inside surface of the lower cylinder.)

ACTUATOR REPAIR, continued

9. Install the lower piston rod sleeve O-ring (Item 38) and install the piston rod sleeve (Item 37).
10. Install O-rings (Items 39 & 40) on middle cylinder head (Item 36). Install the middle cylinder head with the two tapped holes up (which are provided for lifting). Align the marks “↑” with the lower cylinder (Item 42) and the lower cylinder head (Item 50) if they were marked at disassembly. (Note: If they were not marked, align as shown in Figure 50.)
11. Install the upper piston rod O-ring (Item 38). Install the upper piston seal (Item 35 - see detail “C”) on the upper piston (Item 34). Install the upper piston with the two tapped holes up (provided for lifting).
12. Install the spring positioning ring (Item 33). Install and torque the piston rod nut (Item 32). (LS-124 = 330 ft-lbs (447 Nm); LS-185 = 920 ft-lbs (1248 Nm).)
13. LS-124 Actuator Only
 - a. Install the upper collar, bearing (with retainer side facing away from the collar), and hub (Items 29, 28, and 27) on the manual operator stem (Item 16).
 - b. Install the bearing housing (Item 23) on the stem.
 - c. Install the lower bearing (with the retainer side placed on the stem first), bearing collar, and the nut (Items 26, 25, & 24) on the stem (Item 16).
 - d. Install the bearing housing (Item 23) to the spring positioning plate (Item 33) with the cap screws (Item 22).
 - e. Install the spring (Item 21).
 - f. Push down on the upper piston to close the actuator, if not already fully closed.
 - g. Raise the spring loading plate hub (Item 27) and stem (Item 16) until the threaded end of the hub extends above the top of the spring. Hold the hub in position and slip the spring loading plate retaining ring (Item 20) over the stem and screw onto the hub. Tighten securely with spanner wrenches.

LS-185 Actuator Only (see Detail “B”)

- a. Install the lower bearing (with the retainer side placed on the stem first), lower bearing collar, and nut (Items 26, 25, & 24) onto the manual operator stem (Item 16).
 - b. Slip the bearing housing (Item 23) onto the manual operator stem (Item 16). Install the bearing housing with the cap screws (Item 22) to the spring positioning ring (Item 33).
 - c. Install the spring (Item 21). Push down on the upper piston to close the actuator, if not already fully closed.
 - d. Install the spring loading plate (Item 31).
 - e. Install the upper bearing (with the retainer side facing away from the collar), upper bearing collar, and jam nut (Items 28, 29 & 30).
14. Install the upper cylinder (Item 15). (Note: Align marks “↑” if they were marked at disassembly. Be careful not to damage the inside surface of the upper cylinder.)

ACTUATOR REPAIR, continued

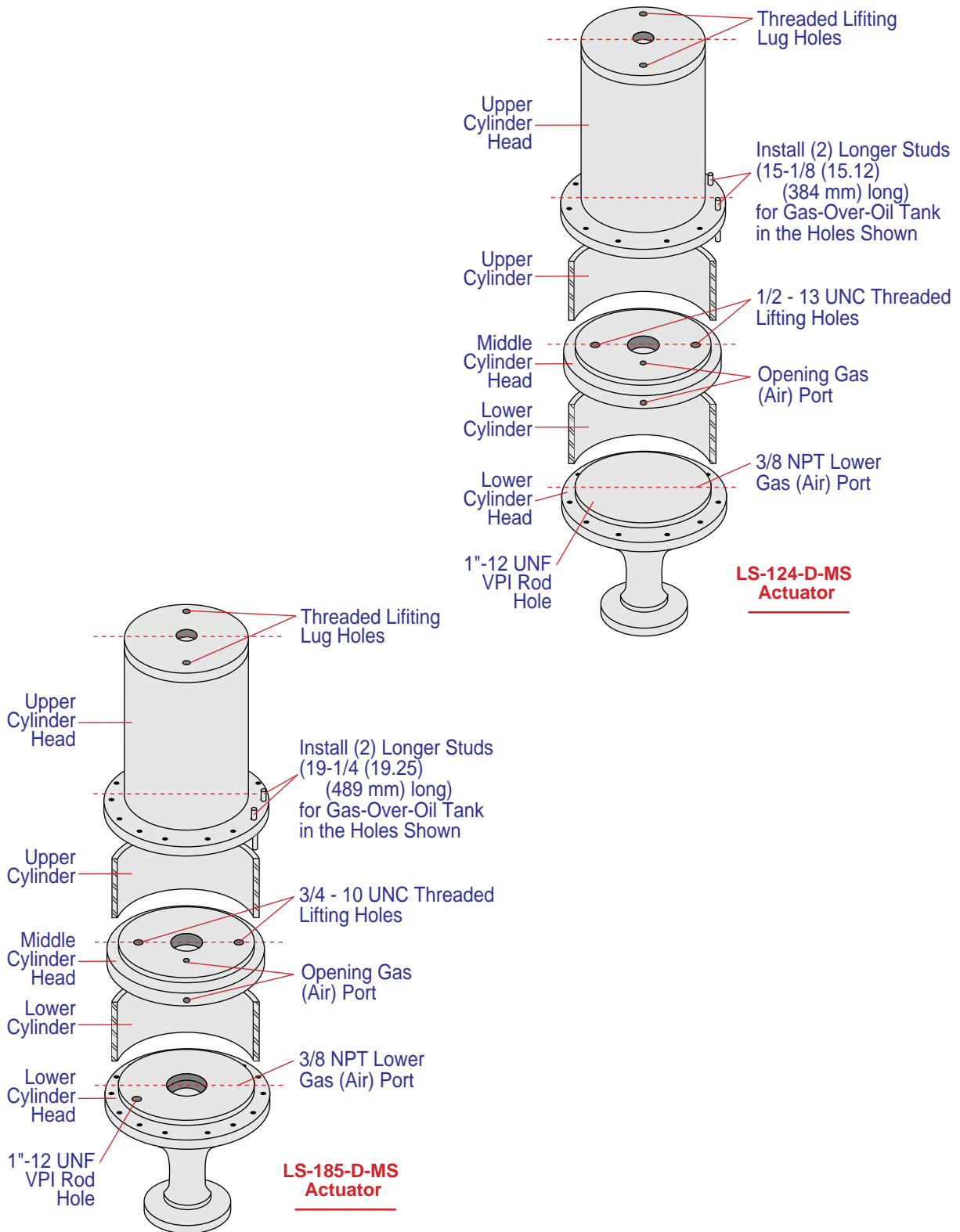

FIGURE 50
Cylinder Head Stacking (Alignment)

ACTUATOR REPAIR, continued

15. Install the upper cylinder head (spring case) (Item 14) and use handwheel to rotate stem counterclockwise ↺ until there is no spring compression and stem rotates freely. Align the marks “↑” with the middle and lower cylinder heads.

(Note: If they were not marked at disassembly, align as shown in Figure 50.)

(Note: If the upper cylinder head does not seat fully due to the spring, install four all-thread studs and nuts that are approximately three inches (76 mm) longer than the regular studs (Item 12). Evenly tighten these down to compress the spring until the rest of the regular studs can be installed. Then, remove the longer studs and install the regular studs. Refer to Figure 47.)

16. Install the studs and nuts (Items 12 & 13) using a criss-cross pattern to tighten. (Note: There are two longer studs and these should be installed as shown in Figure 50 for the gas-over-oil tank.)

17. (TYPE-M-) (LS-124 & LS-185)

Install the jam nut (Item 11) finger tight. (Note: It will be tightened after adjusting the spring compression.)

17. (TYPE-N-) (LS-124 & LS-185)

With handwheel (Item 10) removed, install stem boot, hose clamps, O-ring and collar (Items 56, 53, 54, & 55), then replace handwheel and cotter pin (Items 10 & 9) and turn handwheel until hole in stem is lined up with thru hole in debris cover and install lock pin and cotter hair pin (Items 64 & 63).

18. Install the handwheel and cotter pin (Items 10 & 9).
19. Remove alignment tool Z-2886 and install the VPI rod assembly (Item 8) using the slot in the end of the rod to tighten. (Note: Remove all burrs on the rod with emery cloth.)
20. Install O-ring (Item 7) into VPI rod bushing (Item 6). Slip bushing onto VPI rod assembly (Item 8) and tighten securely into the lower cylinder head.
21. Slip the hose clamp (Item 2) over one end of the rod boot (Item 3) and the pointer clamp (Item 1) over the other end. Install and tighten the hose clamp and rod boot over the VPI rod bushing (Item 6).
22. Install the collar (Item 5) onto the end of the VPI rod assembly (Item 8) with the set screws (Item 4). Slip the rod boot (Item 3) over the collar so that it is about even with the bottom of the collar, and the bottom of the pointer clamp (Item 1) is 1/8 (.12) inch (3 mm) from the bottom of the collar. Then tighten the pointer clamp.
23. Install the gas-over-oil tank as described on page 59. The actuator is now ready to mount to a valve. (See page 11 for the various mounting procedures.)

ACTUATOR REPAIR, continued

DISASSEMBLY OF SPRING-CLOSE ACTUATOR WITH TWO-WAY MECHANISM (LS-205)

The following procedure describes a complete disassembly of the actuator. Orbit recommends removing the actuator from the valve for any internal repairs. However, some internal repairs may be done while the actuator is attached to the valve. Extra safety precautions must be observed to prevent the spring from unexpectedly expanding causing personal injury and equipment damage. These precautions are: (to be done in order),

- a) Close valve. (Note: The valve may tend to open due to pressure in the valve body as the spring compression is released or as the actuator is removed.)
- b) Be sure the gas (air) pressure to the actuator has been reduced to atmospheric and is maintained there. (Note: It is recommended that the pressure supply line be disconnected.)
- c) Turn the handwheel counterclockwise ↺ until it turns freely or until the dimension shown in Figure 51 below is reached.
- d) Refer to Figure 51. Remove four (4) studs and install new, longer all-thread studs and nuts (3 inches (76 mm) minimum longer than existing studs). Remove the remaining shorter studs. Evenly loosen the nuts on the new longer studs so any remaining spring compression will be released.

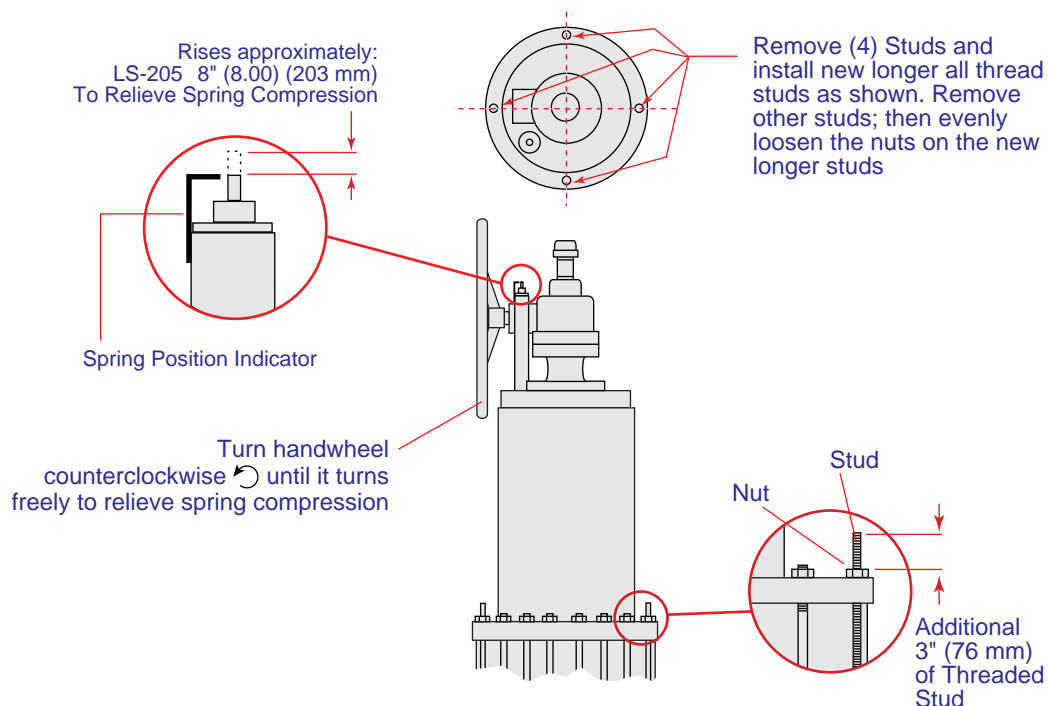
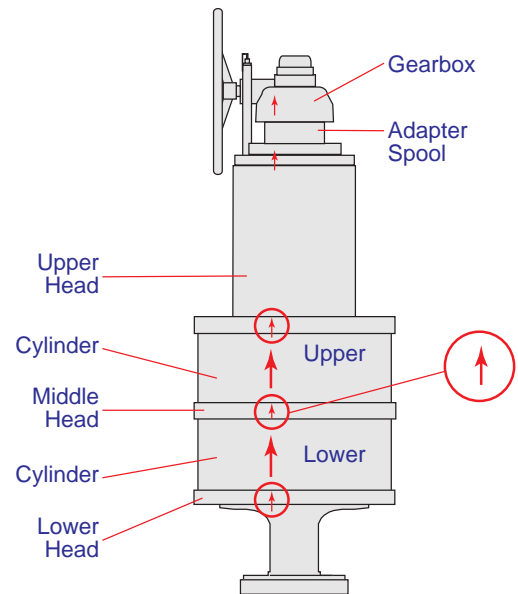

FIGURE 51
Removing Spring Case when Actuator is Attached to Valve

ACTUATOR REPAIR, continued

Refer to Figure 52 for disassembly of the actuator.

1. Mark the orientation of the actuator upper, middle, and lower heads, the upper & lower cylinders, and the adapter spool & gearbox using an arrow “↑” with something that will not rub off (such as paint, marking pen, scribe, etc.). Also, mark the upper & lower cylinders with the words, “upper” and “lower”. This will greatly aid in reassembly later. See illustration at right.
2. Remove the pointer clamp, hose clamp, and rod boot (Items 1, 2, & 3).
3. Loosen the set screws (Item 4) and remove the collar (Item 5). Remove any burrs on the VPI rod (Item 8) with fine emery cloth. Remove the VPI rod bushing (Item 6), and then the O-ring (Item 7).
4. Securely bolt or clamp the actuator to a clean work bench. This is necessary to restrain the actuator while loosening the highly torqued piston rod nut (Item 42) later in the disassembly.
5. Remove, only if damaged, the pipe cap and nipple (Items 9 & 10).
6. Remove the spring position indicator and seal (Items 11 & 12). (Note: The spring position indicator is not normally disassembled, but detail “A” is provided in case such a need should arise.)
7. Remove the cap screws (Item 13).
8. Remove the entire gearbox (Item 14) and adapter spool (Item 15) assembly by rotating it clockwise ↻ until it comes free from the load stem (Item 16).
9. Remove the cap screws (Item 17) and separate the gearbox and the adapter spool (Items 14 & 15).
10. Remove the bolt, washer, and handwheel (Items 18 & 19) from the gearbox (Item 14). (Note: The gearbox is serviced as a complete unit only.)
11. Remove the key (Item 20).
12. Remove the bearing retainer (Item 21) with a spanner wrench. Remove the drive nut, bearings, wiper ring, and O-ring (Items 22, 23, 24, & 63).
13. Remove, only if damaged, the lube and relief fitting (Items 25 & 26).
14. Remove the studs and nuts (Items 27 & 28).
15. Lift off the upper cylinder head (Item 29) and then the upper cylinder (Item 30). Be careful not to damage the inside surface of the cylinder. Remove, only if damaged, the filter/breather (Item 41).
16. Remove the nut (Item 31). Remove the bearing, spring loading plate, and spring (Items 32, 33, & 34).



ACTUATOR REPAIR, continued

17. Remove the retainer and stem guide (Items 35 & 36).
18. Remove cap screws (Item 37) and lift off the puller housing and load stem (Items 38 & 16) together.
19. Allow the load stem (Item 16) to drop thru the puller housing (Item 38). The nut and load stem collar (Items 39 & 40) are to remain attached to the load stem.
20. Remove the piston rod nut (Item 42) and the attachment plate (Item 43).
21. Remove the upper piston (Item 44). (Note: Two tapped holes are provided for lifting.) Remove the upper piston seal (Item 45 - see detail "C").
22. Lift off the middle cylinder head and remove the piston rod sleeve (Items 46 & 47). (Note: If the middle cylinder head and sleeve come off together, separate them after removal from the actuator. Two tapped holes in the middle cylinder head are provided for lifting. The pipe and tubing fittings may remain in place unless damaged.) Remove the O-rings (Items 48, 49 & 50).
23. Remove the lower piston with the VPI rod assembly (Items 51 & 8). Remove the lower cylinder (Item 52). Remove the lower piston seal (Item 45 see detail "C") and the cylinder O-ring (Item 48). Unscrew the VPI rod from the lower piston.

NOTES:

- (a) Two tapped holes in the lower piston are provided for lifting.
 - (b) Be careful not to damage the inside surface of the cylinder.
 - (c) If the lower piston and the lower cylinder come off together, separate them after removing from the actuator.
 - (d) The VPI rod may require heating with a propane torch to 350°F (177°C) for a few minutes to degrade the Loctite on the threads.
24. Remove the retaining ring (Item 53).
 25. Pulling quickly upwards on the piston rod (Item 54), pop out the sealing gland (Item 55). Slide the sealing gland over the top of the piston rod. Remove the inner and outer O-rings (Items 56 & 57), then remove the key (Item 58).
 26. Remove, only if damaged, the lube fitting (Item 59) from the lower cylinder head (Item 60). (Note: Pipe and tubing fittings may remain in the lower cylinder head unless damaged.)
 27. Remove two (2) drive screws and nameplate (Items 61 & 62) only if
 - (a) damaged,
 - (b) replacing middle cylinder head, or
 - (c) making changes to the nameplate. See detail "D".
 28. Clean and inspect parts. (Note: Orbit recommends replacing all O-rings and seals any time an actuator is disassembled to prevent future unscheduled repairs because of an O-ring that appeared good.)

ACTUATOR REPAIR, continued

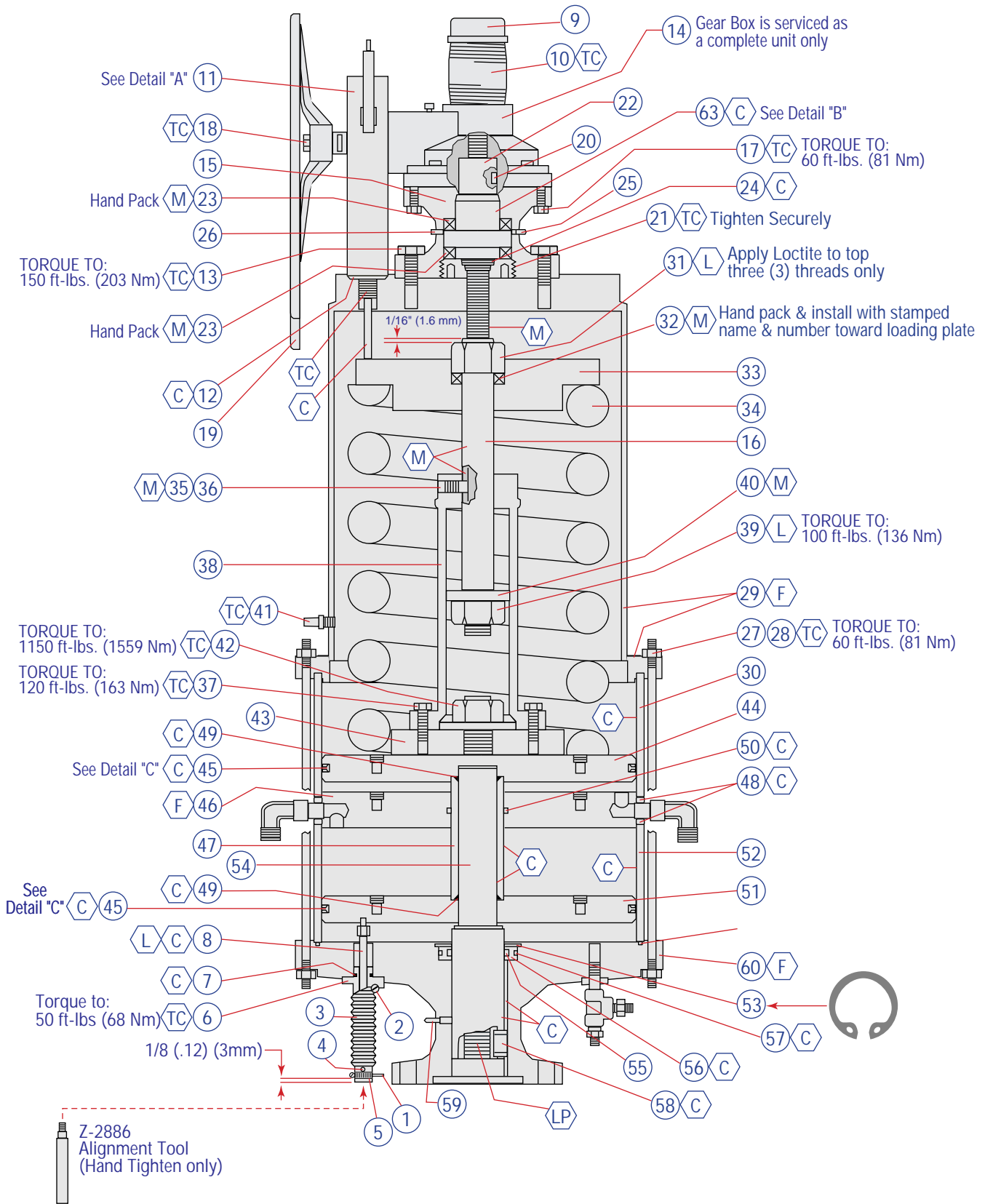

FIGURE 52
LS-205 Spring-Close with Two-Way Mechanism - Disassembly/Assembly

ACTUATOR REPAIR, continued

- | | | |
|---|---|---|
| <ol style="list-style-type: none"> 1. POINTER CLAMP 2. HOSE CLAMP 3. ROD BOOT 4. SET SCREW (2 REQ'D) (1/4"-20) 5. COLLAR 6. VPI ROD BUSHING 7. O-RING (1/2" X 11/16" X 3/32") 8. VPI ROD ASSY 9. PIPE CAP 10. PIPE NIPPLE 11. SPRING POSITION INDICATOR 12. SEAL 13. CAP SCREWS 14. GEAR BOX 15. ADAPTER SPOOL 16. LOAD STEM 17. CAP SCREWS 18. BOLT & WASHER 19. HANDWHEEL 20. KEY 21. BEARING RETAINER | <ol style="list-style-type: none"> 22. DRIVE NUT 23. BEARINGS (2 REQ'D) 24. O-RING (1-5/8" x 1-3/16" x 3/32") 25. LUBE FITTING 26. RELIEF FITTING 27. STUDS 28. NUTS 29. UPPER HEAD 30. UPPER CYLINDER 31. NUT 32. BEARING 33. SPRING LOADING PLATE 34. SPRING 35. RETAINER 36. STEM GUIDE 37. CAP SCREWS 38. PULLER HOUSING 39. NUT 40. LOAD STEM COLLAR 41. FILTER / BREATHER 42. PISTON ROD NUT | <ol style="list-style-type: none"> 43. ATTACHMENT PLATE 44. UPPER PISTON 45. PISTON SEAL 46. MIDDLE HEAD 47. PISTON ROD SLEEVE 48. O-RING (19-3/16" x 19-7/16" x 1/8") 49. O-RING (2-1/4" x 2-1/2" x 1/8") 50. O-RING (3" x 3-3/8" x 3/16") 51. LOWER PISTON 52. LOWER CYLINDER 53. RETAINING RING 54. PISTON ROD 55. SEALING GLAND 56. O-RING (3" x 3-3/8" x 3/16") 57. O-RING (4-1/8" x 4-3/8" x 1/8") 58. KEY 59. LUBE FITTING 60. LOWER HEAD 61. DRIVE SCREWS 62. NAMEPLATE 63. WIPER RING |
|---|---|---|

- NOTES:**
- Ⓢ Coat with Lubriplate LM-123-006 grease
 - Ⓛ Apply Loctite No. 262 to thread
 - ⓉⓈ Apply FEL-PRO "C-102" anti-seize lubricant to threads
 - Ⓜ Apply or pack with Molykote "G" paste
 - ⓔ Refer to Figure 53 for proper head stacking orientation
 - ⓁⓅ Apply Lubriplate "930-AA" lubricant to threads

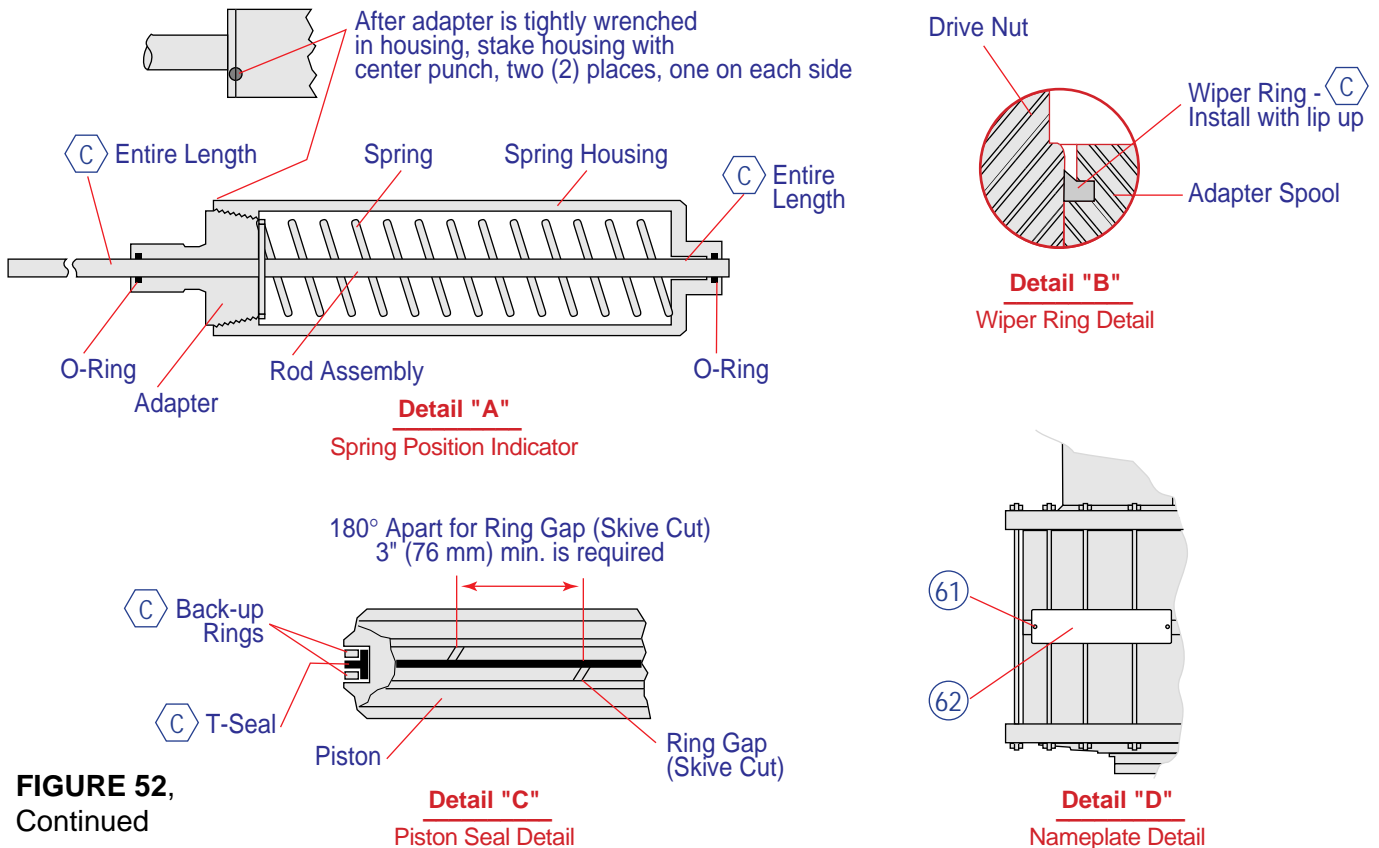

FIGURE 52,
Continued

ACTUATOR REPAIR, continued

ASSEMBLY OF SPRING-CLOSE ACTUATOR WITH TWO-WAY MECHANISM (LS-205)

Refer to Figure 52 for assembly of the actuator (lubricate at the points noted in the figure, during assembly.)

1. If removed, attach the nameplate (Item 62) with two (2) drive screws (Item 61). (See detail "D".)
2. If removed, install the lube fitting (Item 59).
3. Securely bolt or clamp the lower cylinder head (Item 60) to a clean work bench. This will be necessary later in the assembly to restrain the actuator while tightening the highly torqued piston rod nut (Item 42).
4. Install the flat key (Item 58) into the piston rod (Item 54). Slide the piston rod and flat key into the lower cylinder head (Item 60).
5. Install the inner and outer O-rings (Items 56 & 57) on the sealing gland (Item 55). Slip the sealing gland with O-rings over the piston rod (Item 54) and into the recess in the lower cylinder head (Item 60). (Note: It may be necessary to tap it into place using a soft faced hammer and a block of wood.) Install the retaining ring (Item 53) in the ring groove in the lower cylinder head. (Note: Check carefully that the ring fully seats into the ring groove.)
6. Screw the alignment tool Z-2886 hand tight into the threaded hole in the lower piston (Item 51). Install the piston seal (Item 45 - see detail "C") on the lower piston. Install piston so that the alignment tool drops through the hole for the VPI rod bushing (Item 6). (Note: Two tapped holes are provided in the top of the piston for lifting.)
7. Install the lower cylinder head O-ring (Item 48) on the lower cylinder head (Item 60). Install the lower cylinder (Item 52). Be careful not to damage the inside surface of the cylinder. (Note: Match up the alignment marks "↑" on the cylinder and lower cylinder head if they were marked at disassembly.)
8. Install the lower piston rod sleeve O-ring (Item 49) and install the piston rod sleeve (Item 54).
9. Install O-rings (Items 50 & 48) on middle cylinder head (Item 46). Install the middle cylinder head with the two tapped holes on the top (which are provided for lifting). Align the marks "↑" with the lower cylinder (Item 52) and the lower cylinder head (Item 60) if they were marked at disassembly. (Note: If they were not marked, align as shown in Figure 51.)
10. Install the upper piston rod O-ring (Item 49). Install the piston seal (Item 45 - see detail "C") on the upper piston (Item 44). Install the upper piston with the two tapped holes on the top (which are provided for lifting.)
11. Install the attachment plate (Item 43). Install and torque the piston rod nut (Item 42). Torque = 1150 ft-lbs (1559 Nm).
12. If removed, or when installing a new load stem (Item 16), install the load stem collar and nut (Items 40 & 39). Remove any burrs on the load stem, caused by tightening the nut, with a small file and fine emery cloth. Be sure to use Loctite on the nut.

ACTUATOR REPAIR, continued

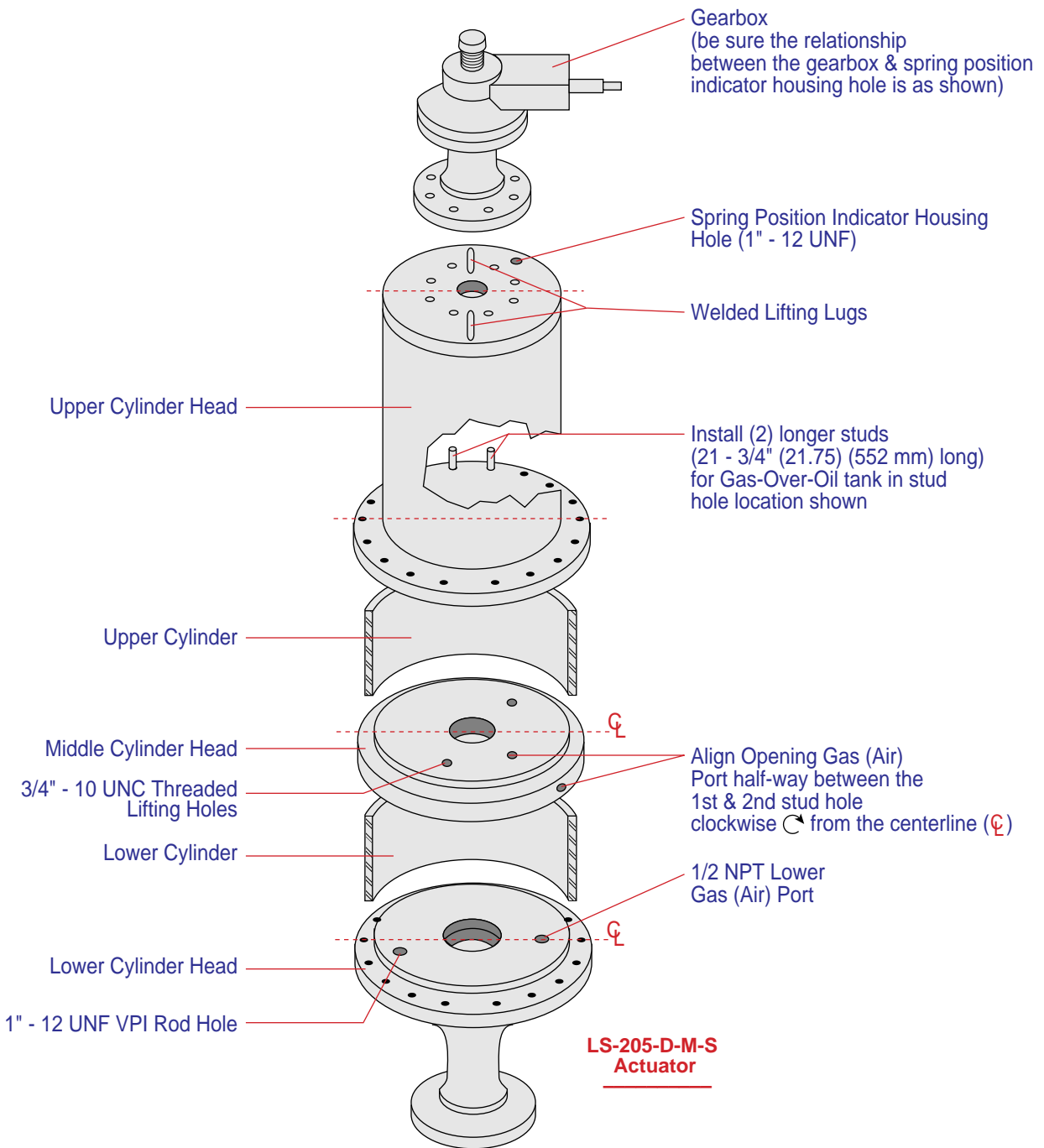

FIGURE 53
Cylinder Head Stacking (Alignment)

ACTUATOR REPAIR, continued

13. Install the puller housing (Item 38) on the load stem (Item 16). Attach the puller housing to the attachment plate (Item 43) with the cap screws (Item 37).
14. Install the stem guide (Item 36) in the groove on the load stem (Item 16). Seat firmly and then back off 1/2 turn. Install the retainer (Item 35).
15. Push down on the upper piston (Item 44) to close the actuator, if not already fully closed. Install spring (Item 34).
16. Lift the load stem (Item 16). Install the spring loading plate, bearing and nut (Items 33, 32 & 31). (Note: Be sure to hand pack the bearing and install with stamped name and number toward loading plate.) Tighten nut until 1/16 inch (1.6 mm) thread is exposed at top.
17. Install the upper cylinder (Item 30). (Note: Align marks “↑” if they were marked at disassembly.)
18. Install the upper cylinder head (spring case) (Item 29) and align the marks “↑” with the middle and lower cylinder heads. (Note: If they were not marked at disassembly, align as shown in Figure 53.) (Note: If the cylinder head does not seat fully due to the spring, install four all-thread studs and nuts that are approximately three inches (76 mm) longer than the regular studs (Item 27). Evenly tighten these down to compress the spring until the rest of the regular studs can be installed. Then remove the longer studs and install the regular studs. Refer to Figure 51.)
19. Install the studs and nuts (Items 27 & 28) using a criss-cross pattern to tighten. (Note: There are two longer studs and these should be installed as shown in Figure 53 for the gas-over-oil tank.)
20. Install, if removed, the lube and relief fittings (Items 25 & 26) into the adapter spool (Item 15).
21. Install the O-ring (Item 24) onto the drive nut (item 22). Install the wiper ring (Item 63 - detail “B”) into the adapter spool (Item 15). Install into the adapter spool the bearings, drive nut, and bearing retainer (Items 23, 22, & 21). (Note: Be sure to hand pack the bearings and to properly install the wiper ring as shown in detail “B”).
22. Install the key (Item 20) into the drive nut (Item 22) on the adapter spool assembly. Install the gear box (Item 14) onto the adapter spool assembly using the cap screws (Item 17). (Note: Align marks “↑” if they were made at disassembly.) Install the handwheel, washer, and bolt (Items 19 & 18).
23. Install the gearbox and adapter spool assembly onto the actuator by rotating it counterclockwise ↺ on the load stem (Item 16). Align the marks “↑”. (Note: If no marks were made at disassembly, align as in Figure 53.)
24. Install, if removed, the pipe cap and nipple (Items 9 & 10).
25. Install the spring position indicator (Item 11 - detail “A”) using a new seal (Item 12).

ACTUATOR REPAIR, continued

26. Remove alignment tool Z-2886 and install the VPI rod assembly (Item 8) using the slot in the end of the rod to tighten. (Note: Remove all burrs on the rod with emery cloth.)
27. Install O-ring (Item 7) into VPI rod bushing (Item 6). Slip bushing onto VPI rod assembly (Item 8) and tighten securely into the lower cylinder head.
28. Slip the hose clamp (Item 2) over one end of the rod boot (Item 3) and the pointer clamp (Item 1) over the other end. Install the rod boot onto the VPI rod bushing (Item 6). Tighten the hose clamp.
29. Install the collar (Item 5) onto the end of the VPI rod assembly (Item 8) with the set screws (Item 4). Slip the rod boot (Item 3) over the collar so that it is about even with the bottom of the collar, and the bottom of the pointer clamp (Item 1) is 1/8 (.12) inch (3 mm) from the bottom of the collar. Then tighten the pointer clamp.
30. Install the gas-over-oil tank as described on page 59. The actuator is now ready to mount to a valve. (See page 11 for the various mounting procedures.)

ACTUATOR CONVERSIONS

Conversion of a spring-close actuator to one with a manual two-way mechanism may be done. Disassembly of a large portion of the actuator is required. The sections in this manual on disassembly of the spring-close actuator and assembly of a spring-close with a manual two-way mechanism will aid in the conversion.

Conversion of a spring-close design actuator to a double-acting design actuator may be done. Disassembly of a large portion of the actuator is required. The sections in this manual on disassembly and the sections on assembly in manual 81-M-14 will aid in the conversion.

Due to extensive part differences on some conversions, it is recommended to consider the cost of a complete new assembled unit versus the cost of a conversion kit and the manpower time involved in making the conversion.

MAINTENANCE

LUBRICATION SCHEDULE

1. A minimum of once a year, or every 2,000 cycles.
2. Every three months if the actuator is operated infrequently (once a day or less).
3. Every 1,000 cycles if actuator is operated more than 10 times a day.
4. Every 500 cycles if the actuator is operated in corrosive or other severe service and operated more than 10 times a day.
5. Any time the actuator is repaired or re-mounted to a valve.
6. Any time the actuator has been stored for more than three months and then put into service (even if the actuator has never been used).

NOTE: Actuators that are mounted on high temperature valves, +600°F (316°C) and above, should be lubricated twice as often as recommended above.

LUBRICATION POINTS

Refer to Figure 54.

A standard automotive type grease gun is used to lubricate Orbit actuators and 2 to 10 pumps of grease are required. Cycle the actuator at least once, to evenly distribute the grease.

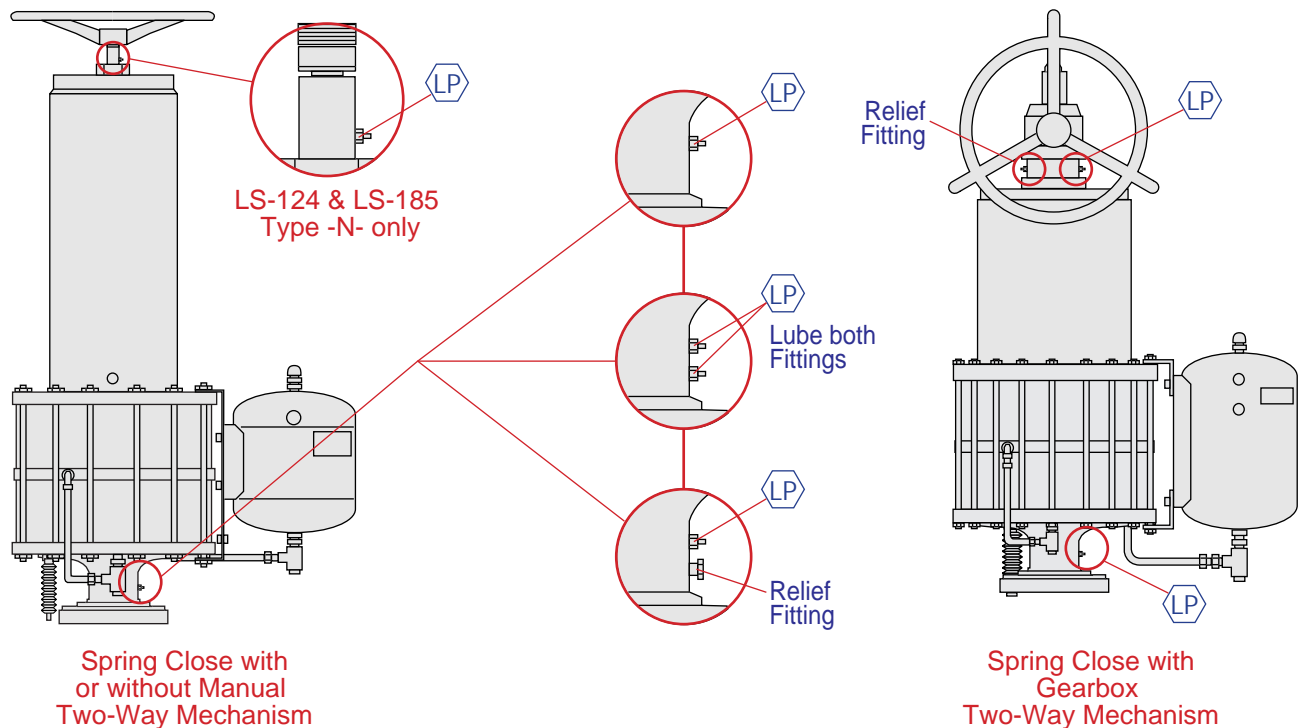

FIGURE 54
Lubrication Points

NOTE: Use Lubriplate "930-AA" lubricant

MAINTENANCE, continued

RECOMMENDED LUBRICANTS

1. Lubriplate "930-AA" lubricant is recommended for pumping into grease fittings.
2. Fel Pro "C-120" anti-seize compound is recommended for use on external threads.
3. Lubriplate "LM 123-006" lubricant is recommended for use on O-rings or surfaces that rub against O-rings.
4. Mobil "ATF 220" automatic transmission fluid is recommended for gas-over-oil tanks.

GAS-OVER-OIL TANK FLUID LEVEL

Refer to Figure 55.

WARNING: The following procedure is for "LS" series actuators only.

1. Cycle the valve/actuator to the full open position. Maintain the valve/actuator in this position while checking or filling the fluid.
2. Remove the fluid level plug on the side of the tank, slowly and cautiously, as fluid could spray from the fill hole if the the tank is over-filled.
3. Fill or drain fluid to bring level to the bottom of the fluid level hole. Replace fluid level plug.

FLUID LEVEL			
ACTUATOR	PLUG SIZE	LEVEL HOLE	APPROX. CAPACITY
LS-124	1/2 NPT	One only	3 gal. US (11 liters)
LS- 185	1/2 NPT	Bottom	6 gal. US (23 liters)
LS-205	1/2 NPT	Top	8 gal. US (30 liters)

4. Cycle the valve/actuator to the closed position, then back to the open position once or twice to purge air from the system. Recheck fluid level in tank. Add additional fluid if necessary.

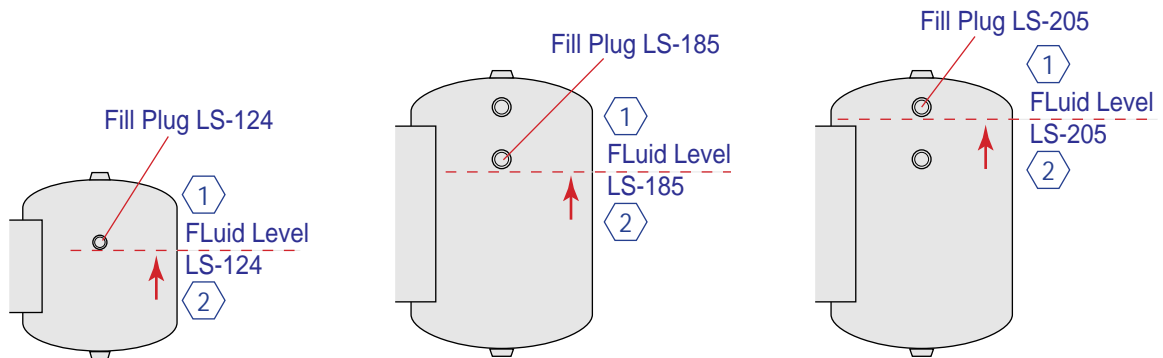

FIGURE 55
Gas-Over-Oil Tank Fluid Level

- NOTES:**
- ① Fluid level with the valve/actuator in the full open position
 - ② The tank MUST be in the vertical and upright position when checking the fluid level and during actuator operation, regardless of the orientation of the valve/actuator

ACCESSORIES

INSTRUMENTATION PANELS

Generally all instrumentation packages mounted to Orbit "LS" series cylinder actuators with three (3) or more components are panel mounted. Figure 56 below shows how to remove or install an instrument panel on the various size actuators. The instrument panel is removed or installed as a unit with all the components mounted. Notice the standard orientation for the instrument panel in relation to the actuator gas-over-oil tank and lower gas (air) inlet. (Actuator is in the vertical and upright position).

NOTE: Some instrument panels may be orientated differently to meet special requirements of some customers.

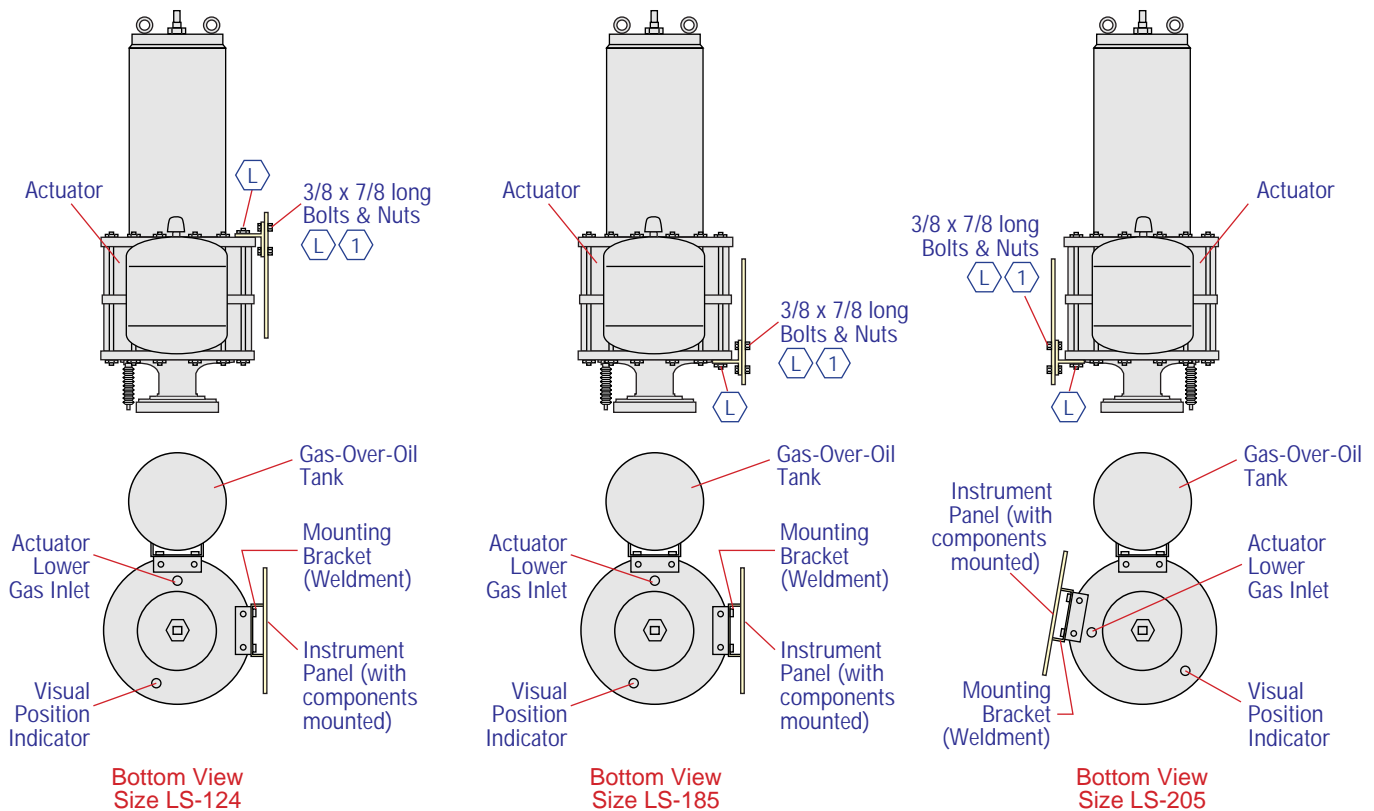

FIGURE 56
Instrumentation Panel - Installation / Removal

- NOTES:**
- Ⓛ Apply Loctite No. 262 to threads
 - ① Either (3) or (4) bolts will be required depending on the panel and piping components mounted on panel. Use (4) whenever possible.

ACCESSORIES, continued

Pressure reserve tank (accumulator)

Figure 57 shows how to remove or install a pressure reserve tank. Notice the standard orientations for the tank are shown in relationship to the actuator gas-over-oil tank. Any of the plugged holes in the tank may be used to connect tubing, but the two 1/2 inch NPT ports on the side of the tank are the preferred connecting points.

NOTE: Some tanks may be orientated differently to meet special requirements of some customers.

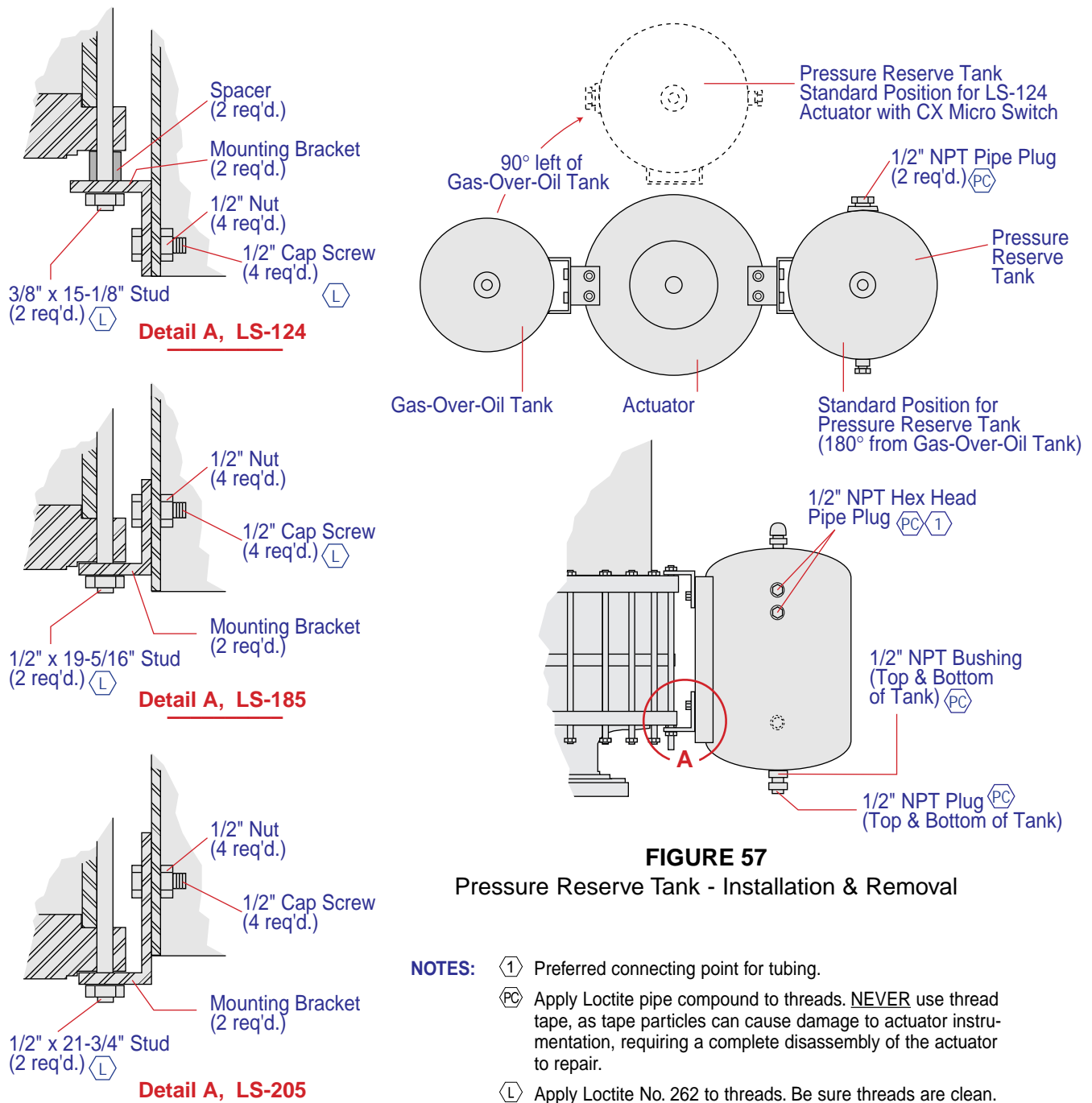

ACCESSORIES, continued

ELECTRIC CX MICRO SWITCH

The standard type CX micro switch is a weather-tight, explosion proof limit switch available in two (2) or four (4) circuit models.

INSTALLATION (CX MICRO SWITCH)

Refer to Figure 58.

1. Attach micro switch (Item 1) on mounting bracket (Item 2) with four (4) nuts & bolts (Item 3).
2. Slip actuator arm (Item 4) into arm clamp (Item 5) to micro switch shaft with socket set screw (Item 6).
3. Attach arm clamp (Item 5) and actuator arm (Item 4) to micro switch shaft with socket set screw (Item 6).
4. Notice the position of the switch assembly in the figure, and remove the two (2) studs & nuts or bolts & nuts (Item 7). Install the mounting bracket with the switch and re-install the studs & nuts or bolts & nuts. (NOTE: Be sure bolts or studs have sufficient thread length. If necessary replace them with longer ones.)
5. Loosen pointer clamp (Item 8) and bottom of rod boot (Item 14).
6. Remove two (2) set screws (Item 9) and collar (Item 10).
7. Attach actuating arm guide (Item 11) to lower threaded hole of actuating clamp (Item 10) with shoulder screw (Item 12). (NOTE: Collar (Item 10) without threaded hole, will not be re-used.)
8. Slip actuator arm (Item 4) thru actuating arm guide (Item 11).
9. Attach and align actuating clamp (Item 10) and actuating arm guide (Item 11) to VPI rod (Item 13) by tightening set screw (Item 9).
10. Slip the end of the rod boot (Item 14) over the actuating clamp (Item 10) so that the distance from the bottom of the actuating clamp to the bottom of the rod boot is 1-5/8 (1.62) inch (41 mm) and the bottom of the rod boot to the bottom of the pointer clamp (Item 8) is 1/8 (.12) inch (3 mm). Then tighten the pointer clamp.
11. Remove switch cover and attach conduit to one or both 3/4 NPT holes in switch housing as required. Refer to applicable wiring diagram for wiring connections. (NOTE: Pipe plug (Item 15) is used to plug 3/4 NPT hole in switch housing if both holes are not used.)
12. Assembly is now ready to have switches adjusted.

ACCESSORIES, continued

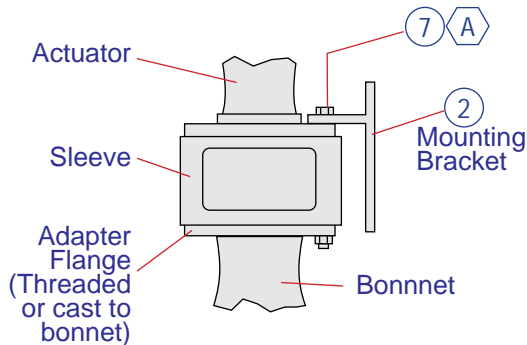
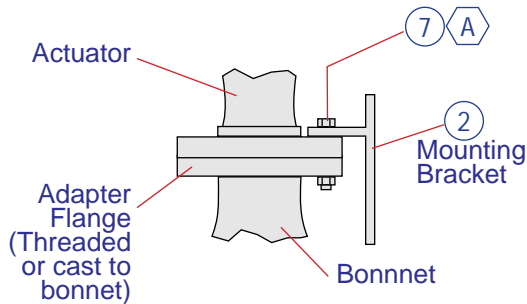
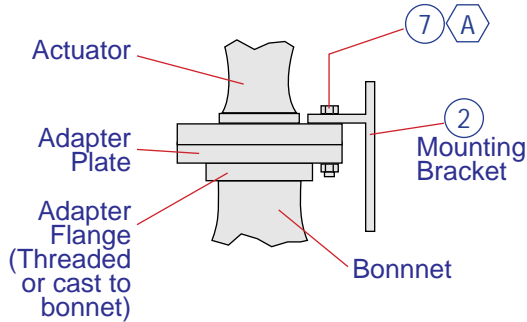

Mounting Bracket Attachments to Various Style Valve Bonnets

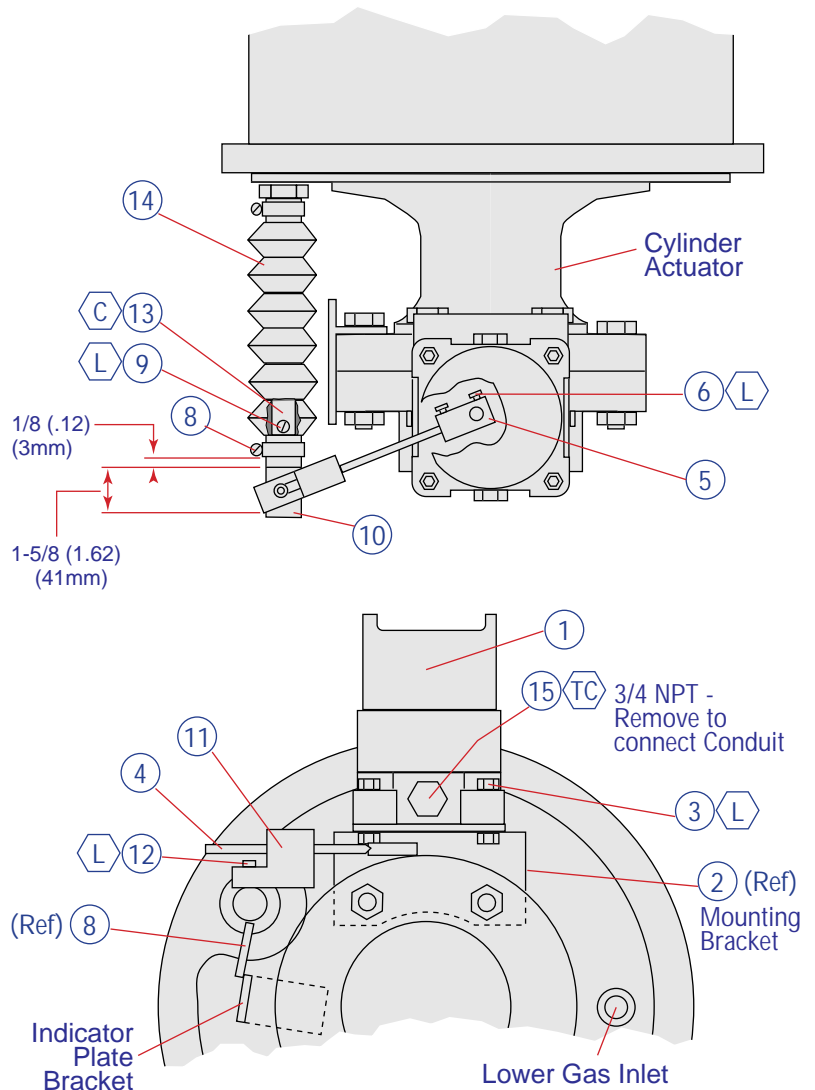

Bottom View

PARTS REFERENCE

- | | |
|---|---------------------------------------|
| 1. CX MICRO SWITCH | 9. SET SCREWS (2 REQ'D) (1/4-20) |
| 2. MOUNTING BRACKET | 10. ACTUATING CLAMP (COLLAR) |
| 3. HEX NUT & BOLT (4 REQ'D) (1/4-20) | 11. ACTUATING ARM GUIDE |
| 4. ACTUATOR ARM | 12. SHOULDER SCREW (NO. 10-24) |
| 5. ARM CLAMP | 13. VISUAL POSITION INDICATOR ROD |
| 6. SOCKET SET SCREW (2 REQ'D) (NO. 10-32) | 14. ROD BOOT |
| 7. STUD & NUTS OR BOLT & NUTS | 15. SHIPPING PLUG (2 REQ'D) (3/4 NPT) |
| 8. POINTER CLAMP | |

FIGURE 58
CX Switch Installation and Removal

- NOTES:**
- (A) TORQUE TO:
120 ft-lbs (163 Nm) for 5/8" bolt or stud
200 ft-lbs (271 Nm) for 3/4" bolt or stud
 - (TC) Apply Fel-Pro "C-102" Anti-seize compound
 - (L) Apply Loctite No. 262 to threads
 - (C) Coat with Lubriplate No. LM123-006

ACCESSORIES, continued

REMOVAL (CX MICRO SWITCH)

To remove the CX micro switch assembly, reverse the installation procedure. (NOTE: The pointer clamp (Item 8), rod boot (Item 14), two (2) set screws (Item 9), or actuating clamp (Item 10), need not be loosened or removed)

CX MICRO SWITCH ADJUSTMENT

Refer to figure 59.

Unscrew switch housing cover. To adjust the switch for open, closed, or intermediate position, the actuator must be in that position. Adjust cams, as below, for any or all of the switches in the housing. Replace cover.

Cam adjustment: Lift cam follower and move cam wheel axially to disengage teeth on wheel from teeth on shaft disc. Turn cam wheel and position it so that pointer on cam follower lines up with symbol "Δ" on the cam wheel. In this position, switch will be tripped. Release cam wheel to engage with mating shaft disc and then release cam follower.

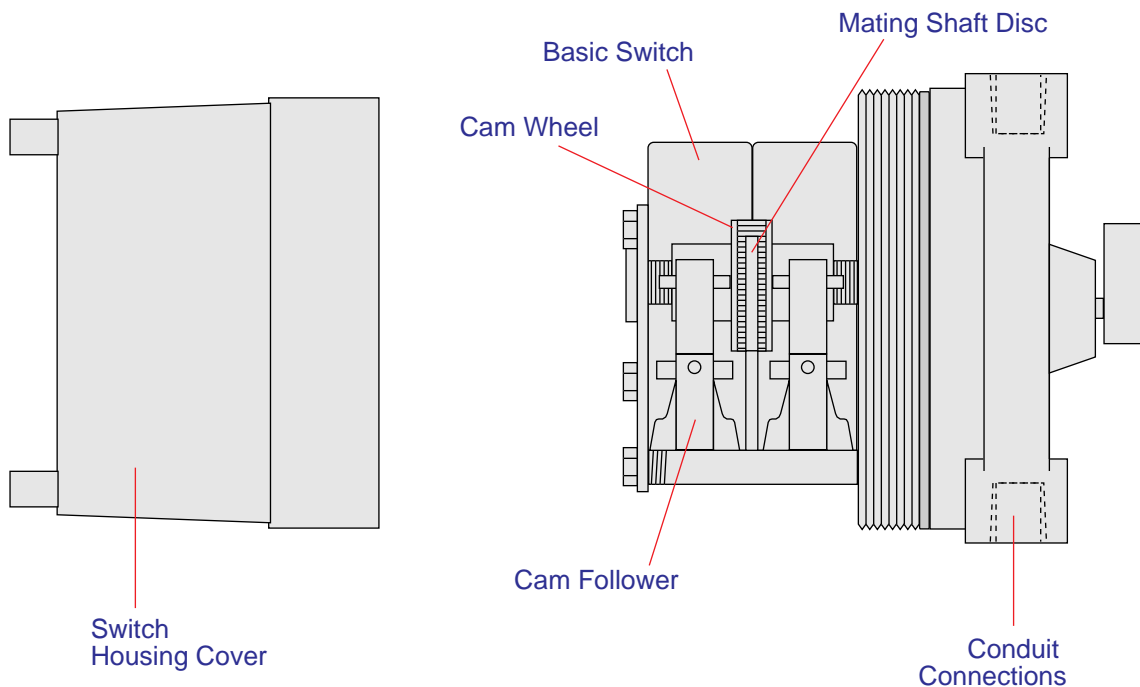

FIGURE 59
CX Micro Switch Adjustment

APPENDIX

MOUNTING DIMENSIONS

ACTUATOR	MOUNTING DIMENSION
LS-124-D-2-XS/MS.....	2-7/8" (2.88) (73 mm)
-3-XS/MS.....	3-9/16" (3.56) (90 mm)
-4-XS/MS.....	3-9/16" (3.56) (90 mm)
-12-XS/MS.....	2-7/8" (2.88) (73 mm)
-13-XS/MS.....	3-9/16" (3.56) (90 mm)
-14-XS/MS.....	3-5/16" (3.31) (84 mm)
-20-XS/MS.....	3" (3.00) (76 mm)
-21-XS/MS.....	2-7/8" (2.88) (73 mm)
-22-XS/MS.....	2-7/8" (2.88) (73 mm)
-23-XS/MS.....	3-9/16" (3.56) (90 mm)
-24-XS/MS.....	3-9/16" (3.56) (90 mm)
-25-XS/MS.....	3-9/16" (3.56) (90 mm)
-26-XS/MS.....	3-5/16" (3.31) (84 mm)
-27-XS/MS.....	2-1/2" (2.50) (64 mm)
LS-185-D-4-XS/MS.....	3-9/16" (3.56) (90 mm)
-5-XS/MS.....	4-7/16" (4.44) (113 mm)
-14-XS/MS.....	3-5/16" (3.31) (84 mm)
-15-XS/MS.....	4-3/16" (4.19) (106 mm)
-20-XS/MS.....	3" (3.00) (76 mm)
-25-XS/MS.....	3-9/16" (3.56) (90 mm)
-26-XS/MS.....	3-5/16" (3.31) (84 mm)
LS-205-D-5-XS/MS.....	4-7/16" (4.44) (113 mm)
-6-XS/MS.....	4-15/16" (4.94) (125 mm)
-15-XS/MS.....	4-3/16" (4.19) (106 mm)
-16-XS/MS.....	4-11/16" (4.69) (119 mm)
-26-XS/MS.....	3-5/16" (3.31) (84 mm)

CONVERSION FACTORS

TO CONVERT	INTO	MULTIPLY BY
LINEAR		
Inches	Millimeters.....	25.40
Millimeters	Inches.....	0.03937
PRESSURE		
Pounds/Sq. Inch.....	Bars	0.06895
Bars	Pounds/Sq. Inch	14.5
TORQUE		
Inch-Pounds	Newton-Meters.....	0.113
Newton-Meters	Inch-Pounds	8.8512
Foot-Pounds	Newton-Meters.....	1.356
Newton-Meters	Foot-Pounds.....	0.7376
TEMPERATURE		
Degree Fahrenheit.....	Degree Centigrade.....	(F-32) ÷ 1.8
Degree Centigrade	Degree Fahrenheit.....	(1.8 x C) + 32



ORBIT VALVE
Division of Cooper Cameron Valves
 7200 Interstate 30 • Little Rock, Arkansas, 72209 U.S.A.
 Telephone (1) 501-568-6000 • Wats (1) 800 643-6544 • Facsimile (1) 501-570-5700
 e-mail: ovc@orbitvalve.com

ORBIT VALVE UNITED STATES FACILITIES

ARKANSAS
 P.O. Box 193520
 Little Rock, Arkansas 72219 U.S.A.
 Telephone (1) 501-568-6000
 WATS (1) 800-643-6544
 Facsimile (1) 501-570-5700

TEXAS
 16500 South Main
 Missouri City, Texas 77489 U.S.A.
 Telephone (1) 281-261-3742
 WATS (1) 800-252-4618
 Facsimile (1) 281-261-3749

SALES REPRESENTATIVES IN THESE U.S. LOCATIONS:

MOBILE, ALABAMA
 LITTLE ROCK, ARKANSAS
 BAKERSFIELD, CALIFORNIA
 LOS ANGELES, CALIFORNIA
 SAN FRANCISCO, CALIFORNIA
 DENVER, COLORADO

ATLANTA, GEORGIA
 LAFAYETTE, LOUISIANA
 NEW ORLEANS, LOUISIANA
 TRAVERSE CITY, MICHIGAN
 ST. LOUIS, MISSOURI
 COLUMBUS, OHIO
 TULSA, OKLAHOMA

PHILADELPHIA, PENNSYLVANIA
 CORPUS CHRISTI, TEXAS
 HOUSTON, TEXAS
 ODESSA, TEXAS
 TYLER, TEXAS
 CASPER, WYOMING

CENTRAL AMERICA SOUTH AMERICA AND MEXICO

ORBIT VALVE
 16500 South Main
 Missouri City, Texas 77489 U.S.A.
 Telephone (1) 281-261-3742
 WATS (1) 800-252-4618
 Facsimile (1) 281-261-3749

EUROPE, AFRICA AND MIDDLE EAST COOPER CAMERON VALVES

Houstoun Road, Livingston,
 West Lothian, EH54 5BZ
 Scotland
 Telephone: (44) 01506 832000
 Facsimile: (44) 01506 441320

CANADA ORBIT VALVE

#600, 715 7th Avenue S.W.
 Calgary, Alberta, Canada
 T2P2X6
 Telephone (1) 403-398-9930
 Facsimile (1) 403-398-9936

ORBIT VALVE DIVISION OF



COOPER CAMERON VALVES

Orbit is a Trademark of Cooper Cameron Corporation,
 Cooper Cameron Valves Division © Copyright 2002,
 Cooper Cameron Corporation, Cooper Cameron Valves Division

ASIA, FAR EAST, INDIAN SUB-CONTINENT COOPER CAMERON VALVES

2 Gul Circle, Jurong Industrial Estate
 Singapore 629560
 Telephone (65) 6861-3355
 Facsimile (65) 6861-7109

AUSTRALIA AND NEW ZEALAND COOPER CAMERON VALVES

283 Burbridge Road
 Suite 43
 Brooklyn Park 5032
 South Australia
 Telephone (61) 8 8352-3077
 Facsimile (61) 8 8352-3066