



INSTALLATION AND OPERATING INSTRUCTIONS FOR AUTOMATIC INSTANTANEOUS TYPE WATER HEATERS FOR USE WITH NATURAL AND LIQUEFIED PETROLEUM GAS

MODEL 125B LPS and 125B NGS (Thermostatically Modulated)

Suitable for heating potable water only

Not approved for space heating purposes

Intended for domestic hot water with preheated inlet water as with solar hot water.



WARNING

If the information in this manual is not followed exactly, a fire or explosion may result causing property damage, personal injury or death.

FOR YOUR SAFETY

Do not store or use gasoline or other flammable, combustible or corrosive vapors and liquids in the vicinity of this or any other appliance.

WHAT TO DO IF YOU SMELL GAS

- Do not try to light any appliance.
- Do not touch any electrical switch; do not use any phone in your building.
- Immediately call your gas supplier from a neighbor's phone. Follow the gas supplier's instructions.
- If you cannot reach your gas supplier, call the fire department.
- Installation and service must be performed by a qualified installer, service agency or the gas supplier.

TABLE OF CONTENTS

Specifications	Page 2
Rules for safe operation	Page 4
Locating the Heater	Page 4
Combustion Air Requirements	Page 5
Mounting the Heater	Page 6
Venting the Heater	Page 7
Gas Connections	Page 10
Water Connections	Page 11
Safety before lighting the pilot	Page 12
Lighting instructions	Page 12
Information on water temperature	Page 13
Maintenance & Service	Page 13
Trouble Shooting	Page 14
Diagram of AquaStar	Page 17
Components and Parts List	Page 19
Warranty	Page 21



WARNING: Improper installation, adjustment, alteration, service or maintenance can cause injury or property damage. Refer to this manual. For assistance or additional information consult a qualified installer, service agency or the gas supplier. Upon completion of the installation, these instructions should be handed to the user of the appliance for future reference.

In the Commonwealth of Massachusetts this product must be installed by a licensed plumber or gas fitter.

FEATURING: Automatic Variable Power Modulating Gas Valve with Thermostatic Control

Warning: If you do not follow these instructions exactly, a fire or explosion may result causing property damage, personal injury or loss of life.

This well engineered, gas water heater has been specially designed to operate with incoming pre-heated water:

It operates on the principle of heating water instantaneously "on demand". When a hot water faucet is opened, cold water flows through the coils of the heat exchanger in the Aquastar. This same flow opens the gas valve, and the burners are ignited by the pilot flame. The heat exchanger coils absorb the heat generated by the burners and transfer heat to the water. When the hot water faucet is shut off, the gas valve automatically closes and the burners turn off. Your hot water faucet is an ignition key to turn on the water heater, giving you control over your hot water energy use. Each time you turn off your hot water faucet, you also shut off the water heater. On the Aquastar "S" model, if the incoming water is colder than the thermostat setting of the heater, the burners will ignite to heat the water in order to boost it and maintain it at the temperature setting. If the incoming water has been pre-heated, (ie) solar, and this water temperature is warm then the burners will modulate down accordingly, or shut down completely if the temperature is as hot or hotter than the heater thermostat setting. The Aquastar 125 BS is the perfect backup to a solar hot water system.

FEATURES

- High Quality Materials for Long Working Life.
- Copper heating coils for endless supply of hot water.
- Burner output proportional to hot water flow demand for maximum energy efficiency.
- Automatic Thermostatic Control for steady hot water temperature
- Input BTU's modulate to zero to prevent overheating of water from pre-heat source
- Safety thermocouple at pilot burner.
- Automatic overheating protection shut-off sensor.
- Stainless steel burners with stabilized blue flame.
- Built-in corrosion resistant draft inducer.
- Compact space saver: mounts on a wall with two hooks.
- Easily removable one-piece cover.
- Easy one person installation.
- Adjustable water flow restrictor to ensure that water flow demand will not exceed the heating capacity of the heater.
- Easy pilot flame lighting with push button piezo ignition.

BOSCH is constantly improving our products, therefore specifications are subject to change without prior notice.

AquaStar 125B LPS and 125B NGS Specifications

Gas Input max.: 117,000 Btu/hr
min.: 23,400 Btu/hr

Water Connection 1/2" Thread fitting NPT

H x W x D 29 3/4" x 18 1/4" x 8 3/4"

Vent 5"

Gas Connection 1/2" NPT thread

Min. Water Pressure 18 Psi at 4 GPM

Max. Water Pressure 150 Psi

Shipping Weight 44 LB

Net Weight 42 LB

1.8 GPM at 90° rise

3.7 GPM at 45° rise

Min. Water Flow 1/2 gal/min

LP GAS Supply Pressure
(before Aquastar regulator) min.: 11" W.C.
max.: 14" W.C.*

Required LP GAS Pressure at inlet
tap while Aquastar is operating: 10.5" W.C.

LP GAS Burner Manifold pressure while Aquastar
is operating at maximum input: 9.0" W.C.

Natural Gas Supply Pressure
(before Aquastar regulator) min.: 7" W.C.
max.: 14" W.C.*

Required Natural Gas Pressure at inlet tap
while Aquastar is operating: 5.7" W.C.

Natural Gas Burner Manifold pressure while Aquastar is
operating at maximum input: 4.2" W.C.

* Inlet gas pressure before Aquastar regulator must not exceed this value. Pressure may need to be adjusted for high altitudes, see page 11.

UNPACKING THE AQUASTAR HEATER

This heater is packed securely. The box includes two water connection fittings, a gas pressure regulator, a pressure relief valve, an incandescent particle tray, two hooks for hanging the heater, this manual, a warranty statement and a warranty registration card. **Do not lose this manual, as there is a charge for replacement.** Please complete and return the enclosed warranty registration card.

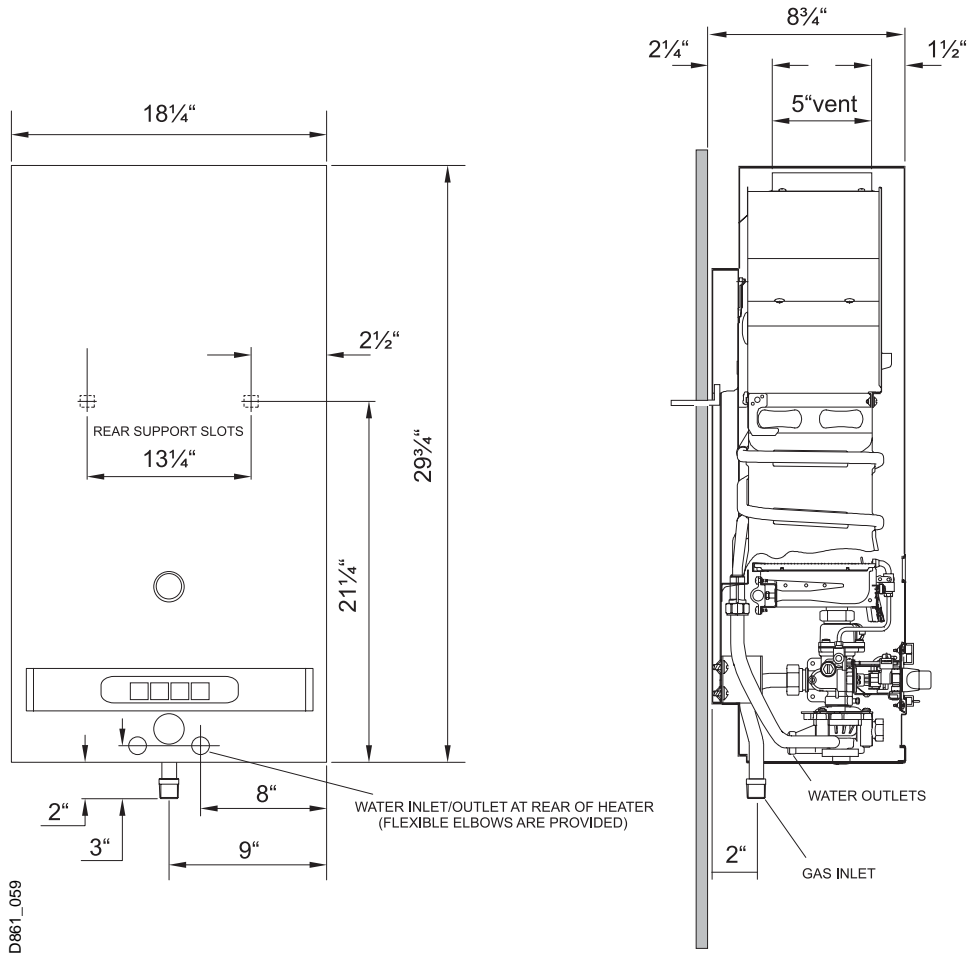

FRONT VIEW

SIDE VIEW

MINIMUM INSTALLATION CLEARANCES FROM COMBUSTIBLE AND NON COMBUSTIBLE MATERIALS FOR ALCOVE OR CLOSET INSTALLATIONS

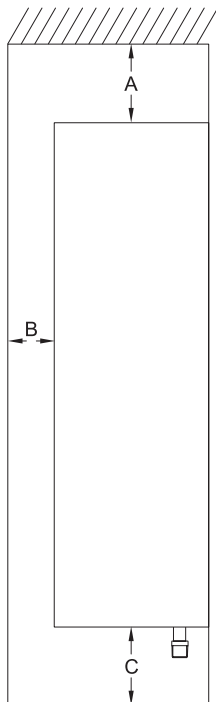

	MODEL 125BS
TOP (A)	12 "
FRONT (B)	4 "
BACK	0 "
SIDES	4 "
FLOOR (C)	12 "
VENT DIAMETER	5 "

AQUASTAR MODEL 125BS

GENERAL RULES TO FOLLOW FOR SAFE OPERATION

1. You should follow these instructions when you install your heater. In the United States: The installation must conform with local codes or, in the absence of local codes, the National Fuel Gas Code ANSI Z223.1/NFPA 54.

In Canada: The Installation should conform with CGA B149.(1,2) INSTALLATION CODES and/or local installation codes.

2. Carefully plan where you install the heater. Correct combustion air supply and flue pipe installation are very important. If not installed correctly, fatal accidents can be caused by lack of air, carbon monoxide poisoning or fire.

3. The place where you install the heater must have enough ventilation. The National Fire Codes do not allow gas fired water heater installation in bathrooms, bedrooms or any occupied rooms normally kept closed. See the section below on locating the heater.

4. You must vent your heater. See section on VENTING, Page 6.

5. The appliance must be disconnected from the gas supply piping system during any pressure testing at pressures in excess of 1/2 Psig (3.5 kPa).

The appliance must be isolated from the gas supply piping system by closing its individual manual shutoff valve during any pressure testing of the gas supply piping system at test pressures equal to or more than 1/2 Psig (3.5Kpa). The appliance and its gas connection must be leak tested before placing the appliance in operation.

6. Keep water heater area clear and free from combustibles and flammable liquids. Do not locate the heater over any material which might burn.

7. **Correct gas pressure** is critical for the optimum operation of this heater (see specifications on page 2). Gas piping must be sized to provide the required pressure at the maximum output of the heater, while all the other gas appliances are in operation. Check with your local gas supplier, and see the section on connecting the gas supply.

8. Should overheating occur or the gas supply fail to shut off, turn off the gas supply at the manual gas shut off valve on the gas line.

9. Do not use this appliance if any part has been underwater. Immediately call a qualified service technician to inspect the appliance and to replace any part of the control system and any gas control which has been underwater.

This product is not approved for manufactured homes (mobile home), recreational vehicles (RV) or boats. Reference ANSI Z21.10.3.

This product is neither designed or approved for outside installations.

PROPER LOCATION FOR INSTALLING YOUR HEATER

Carefully select the location of your new heater. For your safety and for proper heater operation, you must provide an abundant supply of combustion air and a proper venting installation.

The heater may still operate even when improperly vented. It will, however, be less efficient and could eventually damage the heater. It could even result in human sickness or death due to oxygen deprivation and carbon monoxide poisoning. Follow the guidelines below:

1. Place your heater as close to a vent or chimney as possible.

2. National building codes require that you do not install this appliance in bathrooms, bedrooms, unvented closet or any occupied rooms normally kept closed.

3. Simultaneous operation of other appliances such as exhaust fans, ventilation systems, clothes dryers, fireplaces or wood stoves could create a vacuum effect in your home which could cause dangerous combustion by-products to spill back into your home rather than venting to the outside through the flue. Confirm that your Aquastar is venting properly when all these other appliances are running. See section on venting.

Do not obstruct the flow of combustion and ventilation air to the appliance. If installed near a clothes dryer it is very important that the dryer be properly vented. Failure to properly vent a dryer could result in a gradual accumulation of lint on the water heater fin coils and burners, leading to a dangerous condition of vent blockage and poor unsafe combustion.

4. Your hot water lines should be kept short to save energy. It is always best to have hot water lines insulated.

⚠ WARNING: The water in this water heater is cold and always remains cold except for the times that hot water is being used. **DO NOT INSTALL IN AN AREA WHERE IT COULD FREEZE.**

This heater is neither designed for not approved for outside installation. Drain the heater entirely if freezing temperatures are anticipated in the area where heater is installed by disconnecting both the inlet and outlet elbow connections at the rear of heater. Additionally remove the drain plug under the water valve. See Fig 0.

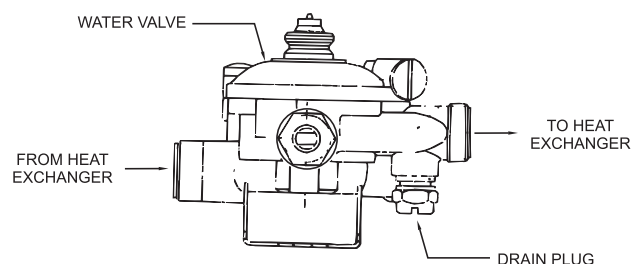

Fig. 0 - Water heater drain plug

⚠ WARNING: Flammable materials, gasoline, pressurized containers, or any other items or articles that are potentially fire hazards must NOT be placed on or adjacent to the heater. The appliance area must be kept free of all combustible materials, gasoline and other flammable vapors and liquids.

COMBUSTION AIR REQUIREMENTS

The AquaStar water heater holds cold water in its copper heat exchanger and brass water valve when not in use. Because of this, any cold air that comes in through the unit's vent pipe is capable of freezing these components. This Installation Manual specifies the minimum vertical vent pipe and the amount of combustion air required for this unit. When all requirements are followed, the unit will operate properly and safely. However, there may still be a risk of freezing due to negative draft if all the combustion appliances in the area are not being supplied with a sufficient amount of make-up air. A wood stove or furnace can rob the make-up air in the AquaStar's vent pipe, leaving the cold infiltrating air capable of freezing the cold water in the AquaStar heat exchanger. More make up air is the solution. Follow the instructions on venting and checking adequacy of make up air. A HVAC specialist should be used to design solutions for providing more make-up air if necessary.

Observe the following instructions concerning combustion air.

Appliances located in unconfined spaces:

- a) An unconfined space is one whose volume is greater than 50 cubic feet per 1000 Btu per hour of the combined rating of all appliances installed in the space. That would be 5850 cubic feet for the AquaStar 125B "S" alone.
- b) In unconfined spaces in buildings of conventional frame, masonry, or metal construction, infiltration is normally adequate to provide air for combustion, ventilation, and dilution of flue gasses.

Appliances located in confined spaces:

The confined space must be provided with two permanent openings, one commencing within 12 inches of the top and one commencing within 12 inches of the bottom of the enclosure. Each opening must have a minimum free area of one square inch per:

- 1000 Btu/hr if all air is taken from inside the building.
- 2000 Btu/hr if all air is taken from the outside by horizontal ducts.
- 4000 Btu/hr if all air is taken from the outside by direct openings or vertical ducts.

Or the confined space must be provided with one permanent opening or duct that is within 12 inches of the ceiling of the enclosure. This opening must have a minimum free area of one square inch per:

- 3000 Btu/hr if all air is taken from the outside by a direct opening or vertical duct.

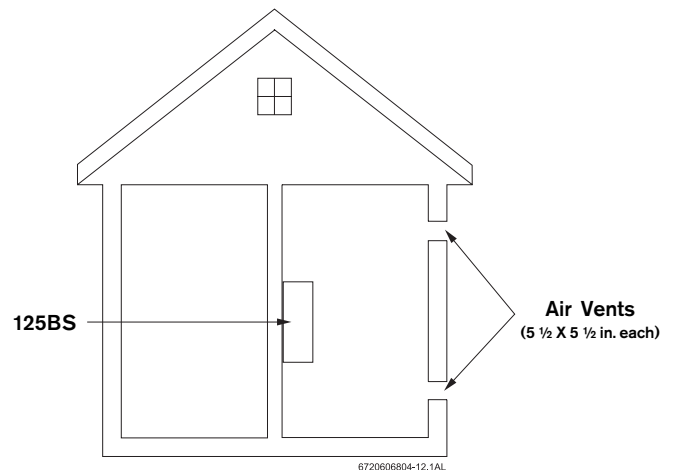
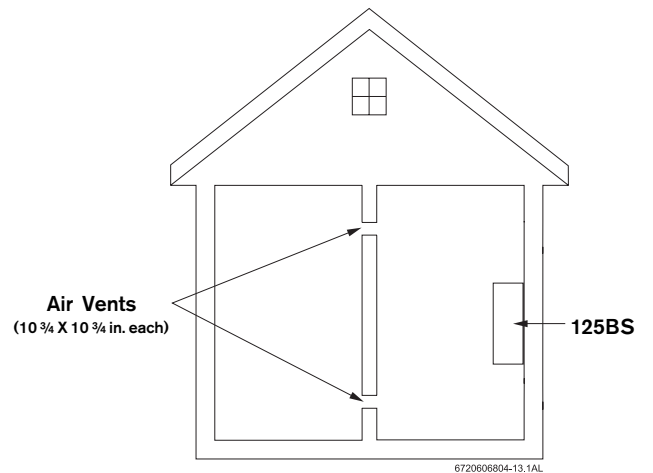

Louvers, grills and screens have a blocking effect. If the effective free area is not known, increase the sizes of your openings by 75% if your louvers are wood and by 30% if your louvers are metal. Refer to the National Fuel Gas Code for complete information. In buildings of tight construction all air should be taken from outside.

CLEARANCES

The Aquastar 125 B "S" is design certified for installation on a combustible wall and for installation in an alcove or closet with the minimum clearances to combustible and non-combustible construction listed below

- A. Top 12 inches (306 mm)
- B. Front 4 inches (102 mm)
- C. Back 0 inches
- D. Sides 4 inches (102mm)
- E. Bottom 12 inches (306 mm)

Clearance from vent is dependent upon the clearance rating of the venting material used. For example, type B-a vent is approved for 1 inch clearance.

Note: Typically, the minimum clearance to combustible materials should not be less than 6" for single wall flue pipe. Note that this clearance can be reduced if combustible materials are protected as per table VI of the National Fuel Gas Code or if Type B gas vent is used.

MOUNTING INSTALLATION

The Aquastar 125 B "S" is design certified for mounting on a wall.

Secure the two L shaped hooks provided with the heater to a wall surface. Place them 13 ¼ inches apart as shown in Fig 1. Do not install this appliance on a carpeted wall or over floor covering which is combustible, such as carpet. The heater must be mounted on a wall using appropriate anchoring materials. If wall is a stud wall sheathed with plasterboard, **it is recommended that support board(s), either 1x4's or 1/2" (minimum) plywood first be attached across a pair of studs and then the heater should be attached to the support boards. See Fig 1.**

Expansion and contraction of piping due to changing water temperature in the pipes imparts movement to the heater which, if mounted directly to a brittle, friable board, such as plasterboard, can cause failure of mounting.

In earthquake-prone zones, BBTNA recommends that installers use a large washer and lag screw through the existing holes used to hang the heater to affix the upper third of the heater to the mounting board. To affix the lower third of the heater, BBTNA recommends that two new holes be drilled in the heater's frame, each one 16 inches below the top two holes, and that washers and lag screws be used to secure the lower portion of the heater to a spacing board. *Before installing the unit, be certain you have the correct heater for your type of Gas – Propane or Natural Gas. Identification labels are found on the shipping box, and on the rating plate which is located on the right side panel of the cover. Also, each burner orifice is stamped with a number (79 for LPG and 120 for Natural Gas).*

The incandescent particle tray (shipped loose in the carton with the water heater) must be attached at the bottom of the water heater front cover at the time of installation. Use the screws provided. See figure 2

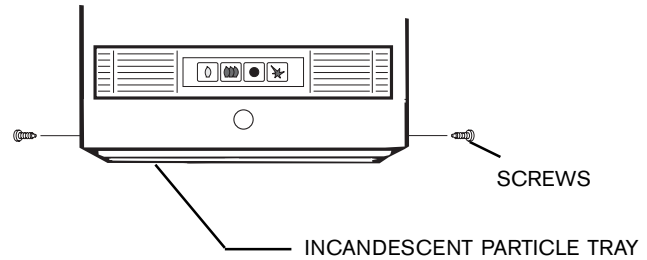

Fig. 2 - Incandescent Particle Tray Illustration

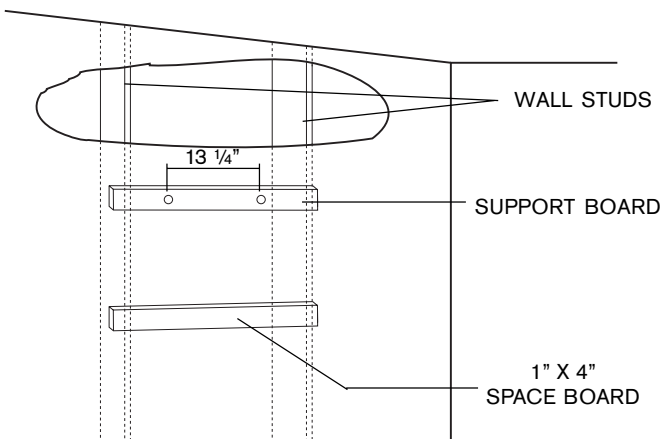

Fig. 1 - Mounting the Heater

VENTING



Vent pipe connection. WARNING: Do not reduce the vent pipe size. See Fig. 3 for high altitude installations

The heater must be vented to the outside following all local ordinances and specifications for installing a gas appliance vent or chimney. The heater must be located as close as practicable to a vertically rising chimney or vent that has a listed vent cap at its termination point. The venting system must be designed and constructed so as to develop a positive flow adequate to remove flue gasses to the outdoors.

Consult the National Fuel Gas Code if the vent will have elbows or share venting with another natural draft appliance. The heater should never be common vented with a mechanically vented appliance. Single wall vent pipe is not recommended, if used consult the National Fuel Gas Code.

Horizontally venting to a sidewall vent terminator or a vertically constructed vent stack along an outside wall of a building is not permissible. A Powervent (Model AQ-1), with a proof-of-draft safety interlock device, is required and is available in order to sidewall vent. Contact your dealer. **In the Commonwealth of Massachusetts: Powervented applications must utilize proof-of-draft safety interlock device.**

VERTICAL GAS VENT: A 5 inch diameter gas vent constructed of double wall Type B gas vent is recommended. 6 inch is required in elevations greater than 2000 feet, see Fig. 3. Any gas vent section that is greater than 45 degrees from the vertical is considered horizontal. Horizontal sections must slope upwards at least 1/4 inch for every foot of its horizontal length and be properly supported. Keep the horizontal section short and avoid too many elbows. The minimum vertical gas vent height allowed is 6 feet; horizontal vent connectors and elbows are not to be considered in the total gas vent height. All gas vent sections must be secured to each other with sheet metal screws and be properly supported.

The gas vent constructed of double wall Type B gas vent must terminate above the roof surface with a listed vent cap at a height that's in accordance with Figure A or B and their table, provided they are at least 8 feet (2.4 m) from a vertical wall or similar obstruction. All other gas vents that are not able to terminate within the minimum specified height allowed must terminate not less than 2 feet (0.6 m) above the highest point where it's passed through the roof and at least 2 feet (0.6 m) higher than any vertical wall or similar obstruction within 10 feet (3.1 m).

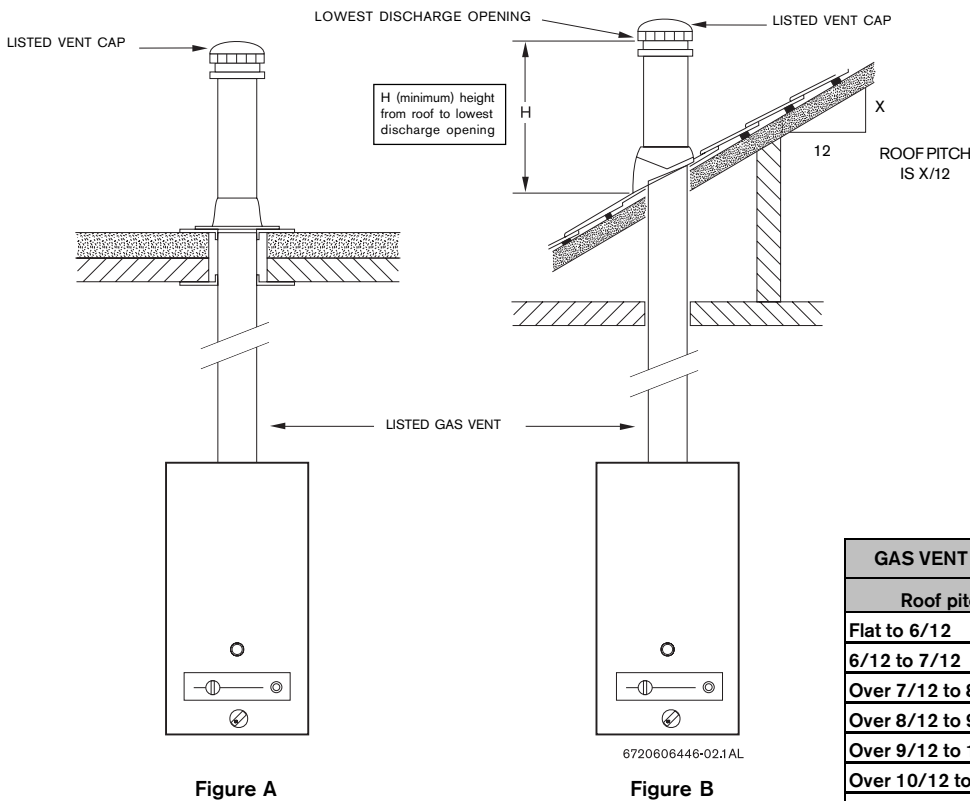

GAS VENT TERMINATIONS FOR LISTED VENT CAPS		
Roof pitch	H (minimum) feet	meters
Flat to 6/12	1.0	0.30
6/12 to 7/12	1.25	0.38
Over 7/12 to 8/12	1.5	0.46
Over 8/12 to 9/12	2.0	0.61
Over 9/12 to 10/12	2.5	0.76
Over 10/12 to 11/12	3.25	0.99
Over 11/12 to 12/12	4.0	1.22
Over 12/12 to 14/12	5.0	1.52
Over 14/12 to 16/12	6.0	1.83
Over 16/12 to 18/12	7.0	2.13
Over 18/12 to 20/12	7.5	2.27
Over 20/12 to 21/12	8.0	2.44

MASONRY CHIMNEY: Masonry chimneys shall be built and installed in accordance with NFPS 211 or local codes. A minimum 5" diameter gas vent pipe (metal double wall Type B), or an approved clay flue liner or a listed chimney lining system must be used when venting into a naturally drafting, internal masonry chimney. 6 inch is required in elevations greater than 2000 feet, see Fig. 3. Local codes may require the use of both gas vent *and* an approved lining system when venting into a masonry chimney. The Commonwealth of Massachusetts requires the use of a listed liner. Lining systems include approved clay flue lining, a listed chimney lining system or other approved material that will resist corrosion, erosion, softening, or cracking from exhaust flue gases at temperatures up to 1800 degrees F. The lining system must be listed for use with naturally drafting, draft hood equipped gas appliances. Follow local codes and refer to NFGC 54 and NFPA 58.

When connecting the water heater to a masonry chimney the following connector guidelines must be followed for safe and proper operation: An approved gas vent connector must be attached to the top of the water heater and rise vertically at least 12" before entering into an approved gas vent connector elbow. Any gas vent section that is greater than 45 degrees from the vertical is considered horizontal. If a horizontal vent connector is to be used to connect the vertical gas vent connector on the top of the water heater to the masonry chimney, that approved horizontal gas vent connector must be kept as short as possible and must be sloped upwards at least 1/4" per foot of its length. This connector must be supported throughout its horizontal length. This horizontal gas vent connection may be no greater than 75% of the total vertical gas flue vent within the chimney. Also, an approved thimble or collar must be used when penetrating a masonry chimney.

A) Existing INTERIOR Masonry Chimney

The metal gas vent pipe should be permanently mounted inside the masonry chimney. Double wall Type B gas vent is recommended. The masonry chimney may have to be tile or metal lined before the insertion of the gas vent pipe; check local codes for clarification. The lining material must be listed for use only with naturally drafting, draft hood equipped gas appliances. Follow manufactures instructions for installation of listed lining material. You may not vent any other fuel burning appliances into any free space remaining in the chimney. The minimum vertical gas vent length within the masonry chimney should be no less than 5 ft (1.5 m); the vent terminator should extend at least 3 feet (0.9 m) above where the chimney meets the roofline and at least 2 feet (0.6 m) higher than any vertical wall or similar obstruction within 10 feet (3.1 m). The top of the gas vent should have an approved vent terminator. See Figure C.

B) Tile Lined INTERIOR Masonry Chimney

The masonry chimney must have an approved liner, ceramic tile, clay or metal. The masonry chimney must be able to accommodate the spent fuel gasses; consult a HVAC engineer for chimney capacity. A common venting like-fuel appliance into this lined masonry chimney is permissible. The chimney's diameter must be large enough to adequately draft the spent fuel gasses. See NFPA 54 for guidelines. A HVAC engineer will be required to spec a chimney system. The minimum vertical chimney length should be no less than 5 ft (1.5 m); the termination point should extend at least 3 feet (0.9 m) above where the chimney meets the roofline and at least 2 feet (0.6 m) higher than any vertical wall or similar obstruction within 10 feet (3.1 m). See Figure C.

C) EXTERIOR masonry Chimney

Refer to the National Fuel Gas Code and consult a local HVAC professional.

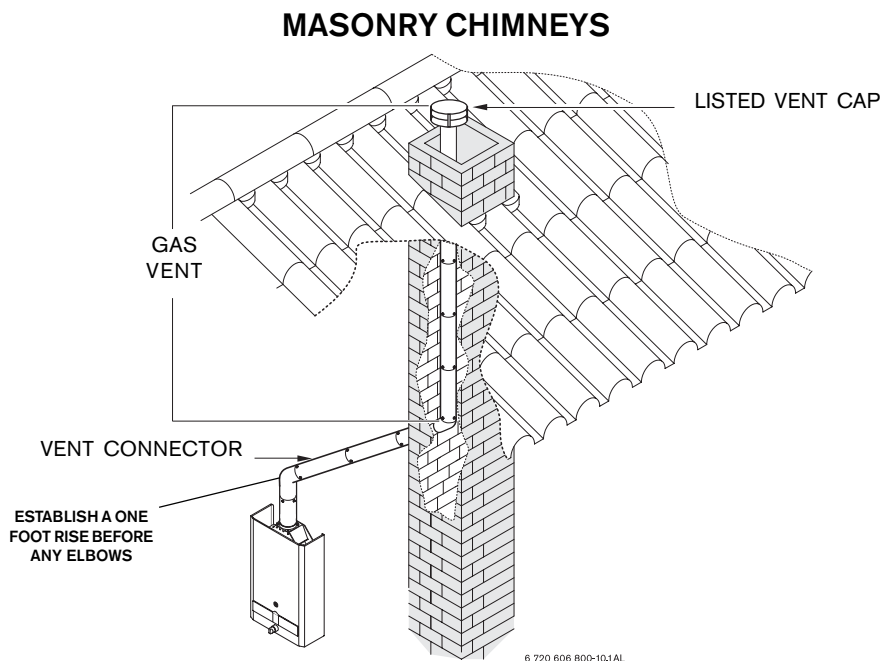

Figure C

To check the draft:

Close all doors and windows to the outside.
Turn on all appliances that force air out of the building. These include all exhaust/ventilation fans, furnaces, clothes dryers, wood burning stoves, etc.
Open all doors between the AquaStar and these other appliances.
Run the unit for at least 10 minutes. Then hold an ordinary mirror at the side above the front shell. Any flue gases backdrafting will cause the mirror to fog. This is a serious health hazard and must be corrected. Poor venting can result in soot building up inside the heater, overheating of the heater and freezing of the heat exchanger in a freezing environment. The mirror will remain clear with a properly functioning draft.

 **WARNING**

Note: The burners of an instantaneous “on demand” water heater such as the AquaStar are only on at the time that hot water is actually being used, the vent pipe is therefore cold except for the short durations when hot water is being used, it is therefore very important that the venting and air supply be adequate to provide a good positive draft as soon as the burners turn on. See venting guide on back page.

The AquaStar 125B”S” instantaneous water heaters have built-in draft diverters and are designed for indoor installation only. The draft diverter outlet must be connected to an unobstructed vent of the same size, or larger.

In Canada, CAN/CGA-B149 Installation Code for detailed requirements
In U.S.A., ANSI Z223.1 - NFPA 54, National Fuel Gas Code for detailed requirements.

The vent connection for the Aquastar 125BS is 5 inches. However, for installations at high altitude (over 2000 feet above sea level) a six inch vent is required. A 5” by 6” vent adaptor must be affixed to the flue collar of the Aquastar with at least two screws. See Fig. 3.

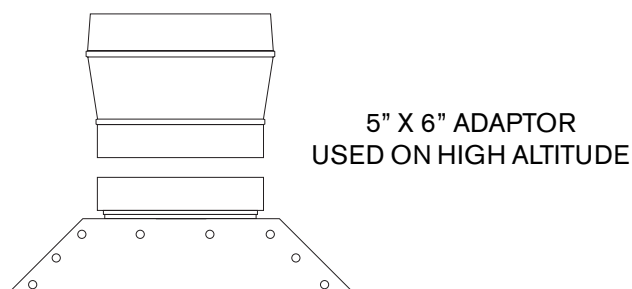



Fig. 3 – Vent Adaptor for High Altitude Installations

 **WARNING:** Failure TO INCREASE THE VENT SIZE TO SIX INCHES AND/or assure that the manifold pressure is set to proper value listed for applications at high altitudes will cause unsafe venting, asphyxiation, and will void CSA Certification.

GAS CONNECTIONS and Gas Regulator



NOTE: The Aquastar 125 B"S" is supplied with a gas pressure regulator that must be installed on the heater before attaching the gas supply line. See figure 5. Failure to install the gas regulator as shown in figure 5 will be a violation of CSA certification of the unit. The regulator supplied with the heater is preset for the gas shown on the rating plate to the correct pressure. It is an appliance level regulator designed for (low inlet) pressure (less than 1/2 Psig or 15" W.C.) DO NOT connect to an unregulated or high pressure propane line or to a high pressure commercial natural gas line.

GAS LINE SIZING

FOR NATURAL GAS

Maximum Capacity of pipe in Cubic Feet of Gas per Hour for Gas Pressure of 0.5 Psig or less and a Pressure drop of 0.3 in Water Column.

(Based on a 0.60 Specific Gravity Gas) Btu numbers given in thousands.

Follow boxed numbers for piping just one Aquastar 125BS (example: 3/4" B.I. Natural Gas pipe for 30 ft. will handle 152,000 btu's). For multiple appliances combine the total btu input load and then refer to applicable chart below.

Nominal Iron Pipe Size, inches	Internal Diameter inches	Length of Black Iron Pipe, Feet													
		10	20	30	40	50	60	70	80	90	100	125	150	175	200
1/4	0.364	32	22	18	15	14	12	11	11	10	9	8	8	7	6
3/8	0.493	72	49	40	34	30	27	25	23	22	21	18	17	15	14
1/2	0.622	132	92	73	63	56	50	46	43	40	38	34	31	28	26
3/4	0.824	278	190	152	130	115	105	96	90	84	79	72	64	59	55
1	1.049	520	350	285	245	215	195	180	170	160	150	130	120	110	100
1 1/4	1.380	1050	730	590	500	440	400	370	350	320	305	275	250	225	210
1 1/2	1.610	1600	1100	890	760	670	610	560	530	490	460	410	380	350	320
2	2.067	3050	2100	1650	1450	1270	1150	1050	990	930	870	780	710	650	610
2 1/2	2.469	4800	3300	2700	2300	2000	1850	1700	1600	1500	1400	1250	1130	1050	980
3	3.068	8500	5900	4700	4100	3600	3250	3000	2800	2600	2500	2200	2000	1850	1700
4	4.026	17,500	12,000	9,700	8,300	7,400	6,800	6,200	5,800	5,400	5,100	4,500	4,100	3,800	3500

FOR LP GAS

Maximum Capacity of Pipe in Thousands of BTU per Hour of Undiluted Petroleum Gases (at 11 inches Water Column Inlet Pressure) (Based on a Pressure Drop of 0.5 Inch Water Column).

nominal Iron Pipe Size, Inches	Black Iron Pipe Length of Pipe, Feet														
	10	20	30	40	50	60	70	80	90	100	125	150			
1/2	275	189	152	129	114	103	96	89	83	78	69	63			
3/4	567	693	315	267	237	217	196	185	173	162	146	132			
1	107	732	590	504	448	409	378	346	322	307	275	252			
1 1/4	220	149	121	103	913	834	771	724	677	630	567	511			
1 1/2	330	229	185	155	141	127	118	108	102	976	866	787			
2	622	433	346	299	264	239	220	204	192	1811	1606	1496			

Maximum Capacity of Semi-Rigid Tubing in Thousands of BTU per Hour of Undiluted Liquefied Petroleum Gases (at 11 inches Water Column Inlet Pressure)

(Based on a Pressure Drop of 0.5 Inch Water Column)

Outside Diameter, Inch	Copper Length of Tubing, Feet									
	10	20	30	40	50	60	70	80	90	100
3/8	39	26	21	19	-	-	-	-	-	-
1/2	92	62	50	41	37	35	31	29	27	26
5/8	199	131	107	90	79	72	67	62	59	55
3/4	329	216	181	145	131	121	112	104	95	90
7/8	501	346	277	233	198	187	164	155	146	138

Fig. 4

* Source National Fuel Gas Code NFPA 54, ANSI Z223.1 - No Additional Allowance is necessary for an ordinary number of fittings

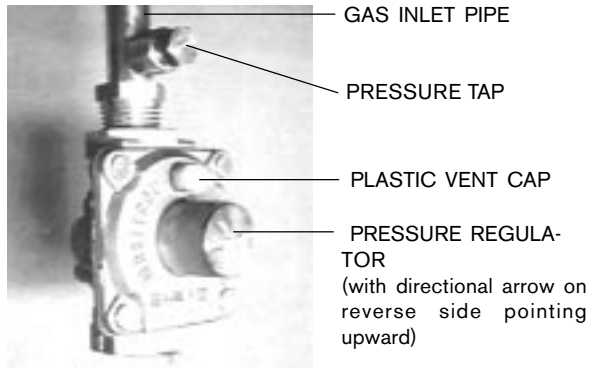

Fig. 5 - Installation of Gas Pressure Regulator

The pressure regulator provided with the heater is adjusted to deliver the proper gas pressure (as indicated on the rating plate and in the manual for altitude up to 2000 feet (660 meters) above sea level. On appliances being installed above 2000 ft (660 meters) elevation, the inlet gas pressure should be set at installation to the value shown below.

NOTE: The gas pressures specified below refer to pressures taken at the test pressure tap on the gas inlet pipe just above the regulator (See Fig 5). These readings should be taken while the heater is operating at full input – i.e. maximum water flow with the temperature dial selector turned all the way clockwise.

MAXIMUM INLET GAS FLOW PRESSURE SETTING

Altitude	Natural Gas inches W.C:	Liquid Propane inches W.C:
0' - 2.000 ft	5.7"	10.5"
2.000 ft - 4.500 ft	4.6"	8.4"

Above 4.500 ft consult your local gas supplier.

GAS LINE SIZING

-It is strongly recommended that the Natural Gas pipe be Black Iron pipe the entire distance from the outside meter to the inlet of the Aquastar regulator. 1/2" Black Iron pipe up to 10 feet, 3/4" Black Iron pipe up to 40 feet and 1" Black Iron pipe up to 150 feet distances. Flex line tubing is NOT recommended, but if used then oversize it.

-It is strongly recommended that the LP Gas pipe be semi-rigid copper or Black Iron pipe from the outside regulator to the inlet of the Aquastar regulator. For semi-rigid copper piping: 5/8" up to 20 feet and 3/4" up to 60 feet distances. For Black Iron piping: 1/2" up to 45 feet and 3/4" up to 160 feet distances. Flex line tubing is NOT recommended, but if used then oversize it.

THESE FIGURES ARE FOR AQUASTAR SUPPLY ONLY, ALL OTHER APPLIANCES IN THE BUILDING WILL NEED TO BE INCLUDED IN THE PIPE SIZING.

National Fuel Gas Code requires that a sediment trap (drip leg) be installed on gas appliances not so equipped. The drip leg must be accessible and not subject to freezing conditions. Install in accordance with the recommendations of the serving gas supplier.

WARNING: The heater must be disconnected from the gas supply piping system during any pressure testing of that system at test pressures in excess of 0.5 psig.

The water heater must be isolated from the gas supply piping system by closing the manual shutoff valve during any pressure testing of the gas supply piping system at test pressures equal to or more than 0.5 psig.

The water heater, including the pressure regulator provided with it, must not be operated at gas supply pressures in excess of 0.5 psig. If overpressure has occurred, such as through improper testing of the gas lines or malfunction of the supply system, the gas valve and regulator must be checked for safe operation. Make sure that the regulator vent is protected against blockage.

When your connections are made, check for gas leaks at all joints (not just the ones you made). Apply some soapy water to all gas fittings and gas valve. **Soap bubbles are a sign of a leak.**

NOTE: Do not apply soap solution to pilot filter screen or pilot orifice area. If you have a leak, shut off the gas. After verifying that required gaskets are in place, tighten appropriate fittings to stop leak. Turn the gas on and check again with a soapy solution. **Never test for gas leaks using a match or flame.**

WATER CONNECTIONS



Install the heater centrally in the building if possible and make hot water piping runs as short as possible. When facing the heater, the cold water inlet will be on the right and the hot water outlet on the left.

Although water piping throughout the building may be other than copper, copper or galvanized piping should be used when connecting to the heaters 1/2" male NPT flex connectors (follow local codes if more stringent). Plastics or other PEX type plumbing line materials are not suitable for connecting directly to the water heater. Keep water inlet pipe to no less than 1/2" (19.05mm) diameter to allow the full flow capacity. If the cold and hot connections to the heater are reversed, the heater will not function.

The Aquastar 125BS is provided with two flexible type connectors that must be connected to the fittings of the water valve as shown in Fig. 6. The union end of the flexible connectors should be attached to the rear inlet ports of the water valve with the supplied washer gaskets. No pipe dope or thread tape is to be used at these joints.

Be certain there are no loose particles or dirt in the piping. Blow out or flush the lines before connecting to the water heater. Full port valves should be installed on both the cold water supply and hot water outlet lines to facilitate servicing the heater (see Fig. 7). For installation on a private well system with the use of a pressure tank, the lowest pressure range setting recommended is 30-50 psi (2.07-3.45 bar).

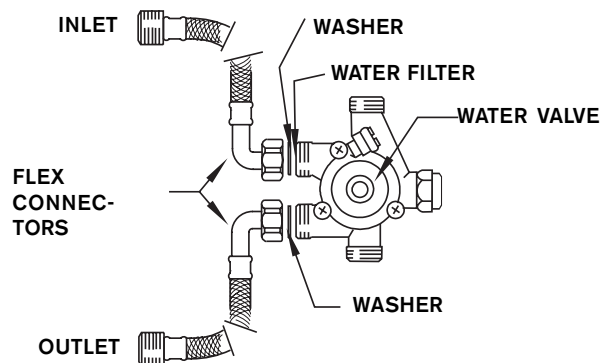

Fig. 6 - Water valve and water connectors, top view

Connecting the pressure relief valve (PRV)

A listed pressure relief valve supplied with the heater must be installed at the time of installation. No valve is to be placed between the PRV and the heater. No reducing coupling or other restriction may be installed in the discharge line. The discharge line must be installed such that it allows complete drainage of both the PRV and the line. The location of the PRV must be readily accessible for servicing or replacement, and be mounted as close to the water heater as possible. See Fig 7. To install the PRV, a suitable fitting connected to an extension on a "T" fitting can be sweated to the hot water line.

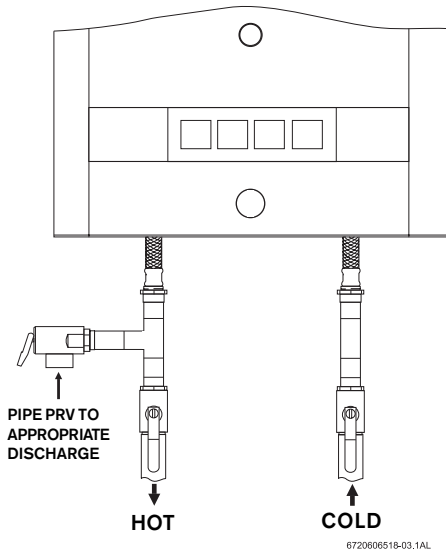

Fig. 7 - Pressure Relief Valve

OPERATING INSTRUCTIONS

Before proceeding with the operation of the heater make sure that the system is filled with water.

Open the cold water inlet supply to the heater fully.

Open a hot water faucet to permit the water to fill the heater and the piping and to eliminate the air trapped in the system. Close the hot water faucet after the water flows freely and all the air has escaped from the system. The water heater is now ready to operate.

FOR YOUR SAFETY READ BEFORE LIGHTING THE PILOT

Warning: If you do not follow these instructions exactly, a fire or explosion may result causing property damage, personal injury or loss of life

A. This appliance has a piezo-igniter for lighting the pilot burner. When lighting the pilot, follow these instructions exactly.

B. BEFORE LIGHTING smell all around the appliance area for gas. Be sure to smell next to the floor because some gas is heavier than air and will settle on the floor.

WHAT TO DO IF YOU SMELL GAS

- Do not try to light any appliance.
- Do not touch any electric switch; do not use any phone in your building
- Immediately call your gas supplier from a neighbor's phone. Follow the gas supplier's instructions.
- If you cannot reach your gas supplier, call the fire department.

C. Use only your hand to push in or turn the gas control buttons. Never use tools. If a button will not push in, check to make sure the buttons are being pushed in the proper sequence. Follow these instructions exactly. If control button(s) are jammed, close the gas supply and call a qualified service technician. Attempted forceful repair may result in a fire or explosion.

D. Do not use this appliance if any part has been under water. Immediately call a qualified service technician to inspect the appliance and to replace any part of the control system and any gas control which has been under water.

LIGHTING INSTRUCTIONS (as seen on front cover of heater)

1. STOP! Read the safety information above on this plate.
2. The gas valve must be turned off by depressing the gas valve off button (●).
3. Wait five (5) minutes to clear out any gas. If you smell gas, STOP! Follow "B" in the safety information above on this plate. If you don't smell gas, go to the next step.
4. The pilot burner is located behind the peephole in the front center of the jacket directly below this instruction plate.
5. Depress PILOT button (●) and light pilot by pushing PILOT IGNITER button (⚡). This may have to be repeated.
6. Observe the pilot flame through the peephole. The pilot button (●) should be held down at least 15 seconds with pilot burning. When the pilot button is released the pilot should continue to burn.
 - If the gas valve button does not pop up when released, stop and immediately call your service technician or gas supplier.
 - If pilot does not stay lit, repeat steps 1 through 6.
 - If pilot will not stay lit after several tries, depress the OFF button (●), and call your service technician or gas supplier.
7. When lit, depress the ON button (●●●). The heater will now fire when water is drawn at a rate greater than the threshold flow rate.

NOTE: If main burner should fail to ignite, make sure pilot is burning. If not, repeat lighting steps 1 through 6.

TO TURN OFF GAS TO APPLIANCE

Depress the OFF button (●) and close the gas supply to the heater.

INFORMATION ABOUT WATER TEMPERATURE

The AquaStar 125B LPS and 125B NGS water heaters have a gas control that modulates burner output in response to water flow. Its purpose is to ensure that the hot water temperature will remain steady, although the water flow demand might vary (down to 1/2 gal/minute). The AquaStar 125 B"S" will produce a temperature rise of approximately 90°F at flow rates between 0.5 and 1.8 gallons per minute unless the water has been preheated. If the incoming water is already hot, the burners will modulate accordingly so the outlet temperature will not exceed 140°F.

Cold water will have to be mixed in at the faucet to produce comfortable temperatures. Mixing in cold water will produce higher flow rates and will reduce risk of scalding. Note: 105° is the maximum recommended temperature for a hot bath. Handwashing should not be done in water hotter than 112° - and cooler for older adults, young children or persons with sensory loss. Remember that scalding can occur in 20 seconds with 135° water.

MAINTENANCE AND SERVICE

(see maintenance table on back of manual)

Approximately once a year, the AquaStar should be checked and cleaned. To remove the front cover, first remove the incandescent particle tray, then unscrew the central screw located at the bottom of the front cover. Pull main cover out toward you and lift up and out. THE FOLLOWING OPERATIONS SHOULD BE PERFORMED BY A QUALIFIED SERVICE PERSON:

Vent System: Should be checked annually. Clean and repair as needed.

Water Valve (Part # 8707002393): The water valve on this heater should be serviced periodically. Lubricate component #27 on page 14 with a small amount of silicon, faucet or lithium grease every two years to keep its o rings fresh and pushrod sliding smoothly. Every 3-5 years replace components #27 and #29 on page 14. The frequency will depend on the mineral content of the water and conditions of use or whenever signs of corrosion appear at the gas and water valve joint. Periodically check that the water inlet filter (#34 on page 14) is clean as well.

Pilot Flame: The pilot flame should burn with a clean sharp blue flame and should resemble the diagram in Fig 8. If the flame is yellow, or if the pilot knob has to remain depressed for a long time in order to keep the pilot lighted, the pilot burner and or the pilot burner orifice may need to be cleaned (NG), the orifice may need to be replaced(LP), and or the air screen may need cleaning. The pilot flame should envelop approximately 10 mm (3/8") of the tip of the thermocouple. If it is too small, the pilot burner must be cleaned. To obtain a spark, the position of the Piezo igniter electrode should be approximately 3 mm (1/8") from the pilot burner tip.

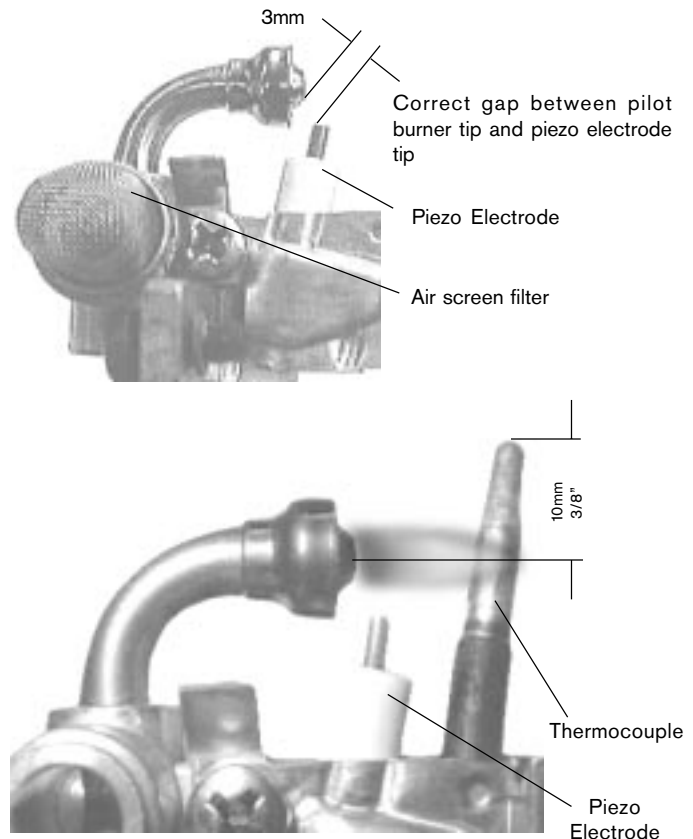

Fig. 8 - Characteristic Pilot Flame

To clean the pilot burner and/ or the pilot orifice : Turn off the gas at the unit. Remove the cover of the heater. To do so, remove incandescent particle tray and unscrew the central screw located at the bottom of the front cover. Pull main cover out toward you and lift up and out. Pull the air screen off, wash it and blow any lint off (See Fig 9). The pilot orifices should also be cleaned or replaced. **Do not enlarge the orifice.** Do not use any wire or sharp object to clean orifices. Natural gas orifices are large enough that you can usually clean them by blowing through them. LP orifices, on the other hand, are too small to clean and should be replaced. See #3 in Trouble Shooting Section. To access the pilot orifice, remove 2 screws holding pilot assembly in place. Then loosen compression fittings to expose pilot orifice.

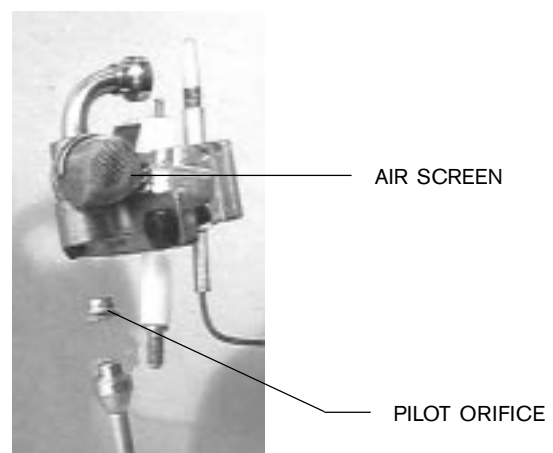

Fig. 9 - Pilot burner with air screen/ pilot orifice

Main Burner Flames: The main burner flames should be blue, with a more intense blue cone in the center core. Yellow flames could be a sign of wrong size gas orifices or dirty burners, or a blockage on the heat exchangers fins.

If some burners have yellow flames while others have good flames, it is likely that dust, lint or spider webs have partially clogged the burner venturis. Contact a gas service person to clean the remove and clean the burners.

Mineral Scale Build-up: The AquaStars heater, when operated at lower temperatures settings, do not accumulate mineral build-up. If however, the water has a high mineral content, periodic descaling may be necessary. The heating coils should be flushed with a descaling solution. Consult your service person.

TROUBLE SHOOTING (see maintenance table)

Introduction

The AquaStar 125 B "S" burners are activated by a water flow valve. Numerous water related problems can cause this water valve to malfunction such as: Insufficient water flow volume to activate the burners at its minimum flow requirement; Dirt in the water flow valve causing it to malfunction; Sediment build-up in faucet aerators, or shower heads; Uneven pressures between cold and hot. (with single lever faucets) Plumbing cross overs. These water flow related problems can cause the heater to deliver less than its full output, or to fail to ignite or to shut down completely.

Problems are stated in upper case, bold face. Most common causes for the problems follow in order of likelihood. The suggested solutions require that the cover be taken off. To do this, remove incandescent particle tray and unscrew the central screw located at the bottom of the front cover. Pull main cover out toward you and lift up and out.

PILOT LIGHT WILL NOT LIGHT

1. No gas to the AquaStar

- A. Gas cock on gas line may not be open.
- B. Gas valve button has not been pushed in on "PILOT" position (●).
- C. Gas regulator may be shut or damaged.

2. In-line AquaStar gas regulator jammed (usually on LP gas)

Replace or unlock the regulator. **Note:** The regulator furnished with the heater is designed for low gas pressure. Excessive pressure will lock it up (propane only). Locking usually happens if the gas pressure between the gas tank (propane) and the water heater's gas regulator has not been reduced. See page 2 for recommended correct gas pressure. To unlock a regulator, consult your gas supplier.

3. Pilot orifice clogged and/or air screen dirty, or pilot gas filter is dirty.

Clogging of the pilot burner can be caused by dust and any suspended matter contained in the ambient air. Although the filters can lengthen the cleaning intervals, they can never completely prevent such clogging. In consequence the gas jet issuing from the pilot orifice is reduced and or the air mixture is reduced. The pilot flame is weak and thus can no longer heat the thermocouple sufficiently. For cleaning purposes, the air filter screen is pulled off, washed and blown out. The pilot orifice has likewise to be cleaned or exchanged. Consult a gas service person to clean the pilot.

4. Air in the Gas Line

Note: Normally this is a problem only at the time of initial installation, after the pipes have been worked on, or after a propane tank has been allowed to empty, or after the heater has been shut down for a long time.

Bleed all the air trapped in the gas line. Because of the very small pilot orifice (especially on LP gas models), bleeding out all the air could take several minutes. Depress the pilot button (●) and depress this button until all the air has escaped, and the gas has arrived. During this process, press repeatedly on the piezo ignition button until the pilot flame has ignited.

PILOT LIGHTS BUT FLAME GOES OUT WHEN BUTTON IS RELEASED

1. Pilot push button was not pushed in far enough or was not held in long enough

Depress the pilot button. Hold it pushed in for at least 15 seconds to give time for the pilot flame to properly heat the tip of the thermocouple.

2. Pilot flame improperly aimed or is too weak so it is not properly heating the tip of the thermocouple.

The Pilot flame should be a sharp blue flame and aimed at the tip of the thermocouple so that it envelops 10 mm (3/8 ") of the thermocouple tip. Pilot flame has to be properly aimed at the thermocouple. See Fig 8.

3. Poor thermocouple connection at the electromagnet

Note: Electromagnet is part #8707201094 located on the right side of the gas valve behind the piezo pushbutton assembly. Check the tightness of the thermocouple connection nut at the electromagnet: The Electro-magnet connection is a large aluminum 17mm hex head nut. The thermocouple end is a 5 mm brass nut which screws into the 17 mm nut. Tighten the thermocouple nut snugly but not too tight.

4. Poor circuit connections at the ECO. (Energy Cut-Off overheat protection)

Oxidation or looseness of the ECO terminal connections can result in millivolt current loss through the thermocouple safety circuit. Clean terminals with very fine sand paper or an eraser and reconnect ECO leads.

5. Faulty ECO (part #8707206017)

If cleaning the terminals attached to the ECO did not fix the problem, connect a jumper wire between the two wires and try to relight the pilot. If the pilot flame now remains on, replace the ECO. If the flame still goes out when the button is released, the ECO is not defective. Go to next step.

6. Faulty thermocouple (part #8747202083) or electromagnet) Unless these 2 parts are at least 8 to 10 years old, it is very unlikely that they are faulty. Before testing, reconfirm that #2 is absolutely correct, and that all connections are clean and tight.

To test the thermocouple, disconnect the thermocouple lead to the ECO. Insert a multi-meter probe into the thermocouple lead and attach or hold the other lead to the metal gas valve (DC common). Light the pilot flame and hold button, meter reading should be 24 mVDC or more. If the reading is 24 mVDC or more the thermocouple is good. To test the electromagnet, re-connect the thermocouple lead to the ECO, light pilot and hold button while taking a reading between the ECO leads and the metal gas valve (DC common). The reading should drop to 19 mVDC or less. If it does not, replace the electromagnet.

BURNERS DO NOT IGNITE WHEN HOT WATER IS TURNED ON

1. Pilot is not on.

Light the pilot. See lighting instructions.

2. Gas valve button not positioned on Burner Position

Be sure once the pilot flame is on, that after a 15 to 20 second wait, the main burner button () is pushed all the way in.

3. Cold incoming water connection made to wrong side of heater

Make sure cold water inlet connection is on the right side of heater when you are facing the heater.

4. Water flow rate at hot water tap is too low.

Note: The AquaStar models 125B"S" require 0.5 gallon per minute flow to activate the burners. This is a flow which would fill a quart jar in 30 seconds.

5. Cold water inlet filter on heater is dirty.

Remove filter and clean. This screen filter is located at the inlet side of the brass water valve (fig. 11, #34). Check and clean faucet aerators too.

6. Crossover in household plumbing

The AquaStar burner activates when there is sufficient water pressure drop in the AquaStar water valve assembly – ie. when a hot water faucet is opened. If there is a crossover in the plumbing, the necessary pressure drop in the AquaStar will be insufficient, or totally eliminated. A plumbing crossover can be caused by a bad washer at a single lever faucet or incorrect plumbing or a mixing valve in the line, etc. which permits hot and cold water to mix in the plumbing. The crossover will create a back pressure in the system preventing the pressure drop in the Aquastar – i.e. cold water is entering the water heater from both sides and the burners will not come on. To confirm there is no crossover in the plumbing, shut off the cold water supply to the AquaStar. Open your hot water taps. There should not be any water flowing. If there is water flowing, there is a crossover in the plumbing. This is a plumbing problem, not an Aquastar problem. Please contact your plumber.

7. Water valve parts may be dirty or components damaged.

Water valve and component parts must be totally free of dirt. First check that the venturi is free of dirt particles. In hard water areas, mineral deposits can eventually (3 to 5 years in hard water areas) corrode the water valve parts to a point where they will need replacing.

Any sign of moisture or corrosion at the joint of the water valve and the gas valve is a sign that the water valve assembly components need to be replaced immediately.

Note: Water valve for model 125B"S" is part # 8707002393 for both LP and NG models. (Contact service person to clean water valve or replace if corrosion is present).

PILOT LIGHT GOES OUT DURING OR IMMEDIATELY AFTER HOT WATER HAS BEEN USED

1. Gas pressure too low

Very low gas pressure may be caused by low delivered gas pressure, a jammed gas regulator or undersized gas lines. If the gas lines are undersized, there may still be the specified static gas line pressure. However when the water valve opens, and gas enters the burners, the pressure could drop sharply, causing the pilot flame to go out.

Have a gas technician confirm the gas pressure both static and at maximum Btu output. Specifications for your heater are on page 2.

2. Pilot may be dirty or weak

See Page 13 for instructions on pilot maintenance.

3. Burners are not shutting down immediately when hot water is turned off

Note: If burners don't shut down immediately when the hot water is turned off, the heater will overheat and the ECO will shut-off the gas. Rebuild the water valve assembly using the repair kit from BBTNA (part #8 703 406 204).

WATER IS TOO HOT

1. Water flow rate is too low.

Increase the flow rate.

2. Not enough cold water mixing at faucet

Contact your plumber to adjust mixing valves on faucets.

3. The heater's fixed degree rise is too high for user

The calibration nut for the thermostat assembly at the gas valve can be adjusted upward to lower the temperature rise. A seal of paint coats two adjusting nuts there, the thin upper one is a lock nut while the lower one is the adjuster. Loosen the lock nut one first. Tighten the adjuster nut incrementally upward and check water temperature, stop when satisfactory. Then tighten down the lock nut. **Caution: Never back the adjuster nut downward to the last thread unless the thermostat is being replaced. This is a gas seal.**

WATER IS NOT HOT ENOUGH

1. Water flow rate is too high.

Decrease the flow rate.

2. Btu input is too low due to insufficient gas pressure ***It is extremely important for a tankless instantaneous water heater to have the right size gas line to obtain the correct gas pressure***

See specifications on page 2. Unlike storage tank water heaters, the burners of a tankless water heater must be very powerful to heat water instantaneously since they do this only at the time hot water is actually being used. It is therefore imperative that the gas pressure requirement be met exactly. Insufficient gas pressure will directly affect the water temperature at the time of usage. See page 2 for correct gas pressure settings.

3. Thermostat calibration is incorrect or thermostat is defective.

Contact your service person or call BBTNA.

4. Btu input is too low due to insufficient gas supply

Make sure your main gas line is fully opened. If using LP gas, be sure that the size of the propane tank is adequate to supply the required gas pressure.

5. Cold water is mixing with the hot water between the AquaStar and the outlet

Compare water temperature at outlet of the AquaStar (hold the AquaStar's outlet pipe with your hand) and at the tap. If these two are very different, check for mixing valve or plumbing crossover (see "MAIN BURNERS WILL NOT IGNITE..." paragraph #6).

6. Parts in water valve are dirty or damaged, which will prevent the gas valve from being fully opened.

Water valve maintenance needs to be performed, see #7 under BURNERS DO NOT IGNITE WHEN HOT WATER IS TURNED ON.

3. Cold water is mixing with the hot water between the AquaStar and the outlet

See #6 under "MAIN BURNERS DO NOT IGNITE WHEN HOT WATER TURNED ON".

4 . Insufficient gas pressure

Note required gas pressures (page 2) and consult gas service person.

HOT WATER TEMPERATURE FLUCTUATES / UNIT DEACTIVATED

1. Unbalanced pressure in waterlines

The added restriction caused by the Aquastar in the hot water system can result in uneven pressures between the cold and the hot. In such cases when mixing cold water at the tap, the lower hot water pressure may be overpowered by a much higher cold water pressure, which may cause the Aquastar burners to shut down (deactivate). Make sure faucet aerators or shower heads are free of minerals.

Do not add any flow restrictor to the shower head.

Typically this deactivation symptom is a result of the hot water being too hot to use comfortably. Warm inlet water generally causes this. Lowering the control knob setting and/or reducing the inlet gas supply to the heater should correct this deactivation symptom.

2. Inlet water pressure is erratic due to inadequate supply water pressure or saturated pressure tank on well system

For installation on a private well system with the use of a pressure tank, the lowest pressure range setting recommended is 30-50 psi (2.07-3.45 bar). Confirm that the pressure tank is not water logged.

Fig. 10 - Diagram of AquaStar 125 BS

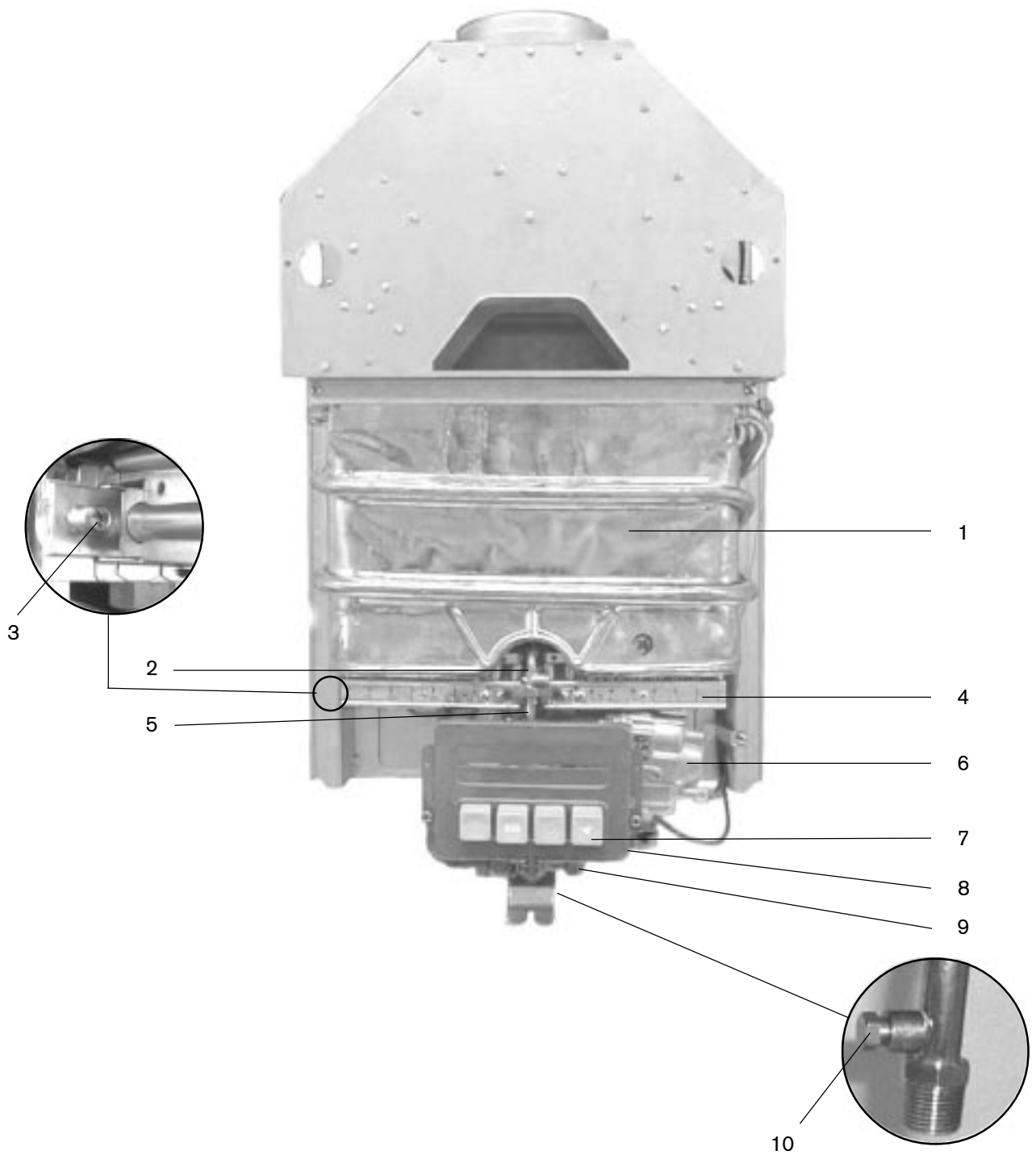

- | | | | |
|----|--|-----|------------------------------------|
| 1. | Heat exchanger | 6. | Gas valve |
| 2. | Pilot assembly | 7. | Piezo igniter |
| 3. | Burner manifold gas pressure test nipple | 8. | Location of pressure tap screw |
| 4. | Main gas burner | 9. | Water valve |
| 5. | Pilot gas tubing | 10. | Gas inlet gas pressure test nipple |

AQ 125 BS

Fig. 11 - INTERIOR COMPONENTS DIAGRAM AND PARTS LIST

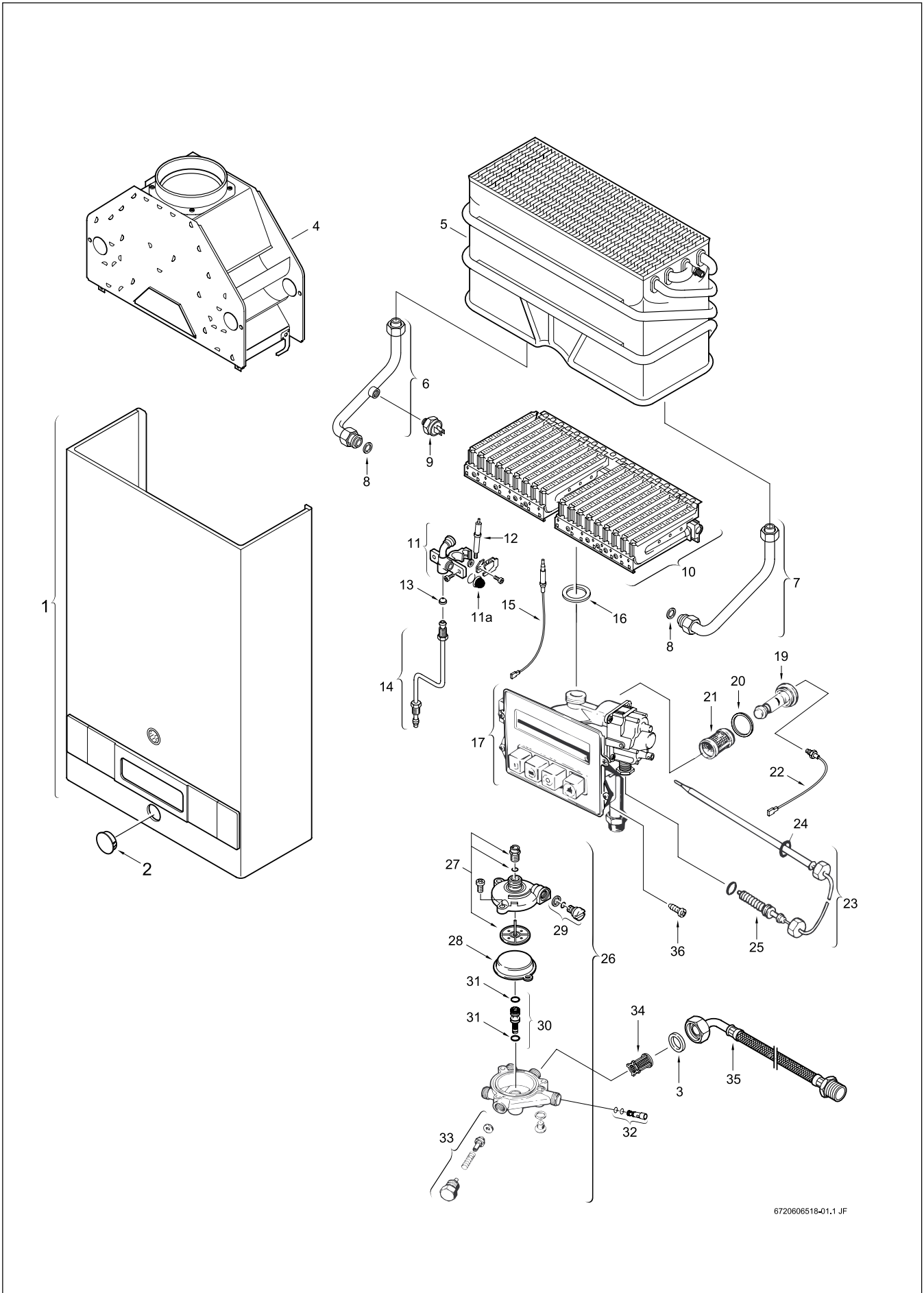

6720606518-01.1 JF

Fig. 11

**INTERIOR COMPONENTS DIAGRAM
AND PARTS LIST 125BS**

1	Cover	8 705 421 033	
2	Cap cover	8 703 304 011	
3	Water connection gasket	8 710 103 043	
4	Draft divertor	8 705 505 354	
5	Heat exchanger	8 705 406 189	
6	Hot water pipe	8 700 705 431	
7	Cold water pipe	8 700 705 294	
8	Heat exchanger washer	8 710 103 045	
9	Overheat sensor (ECO)	8 707 206 017	
10	Main burner assembly	8 708 120 296	LP
	Main burner assembly	8 708 120 298	NG
11	Pilot burner assembly	8 718 105 051	
11a	Pilot filter screen	8 700 507 055	
12	Piezo electrode	8 708 107 002	
13	Pilot orifice	8 708 200 005	NG
	Pilot orifice	8 748 200 173	LP
14	Pilot Tube	8 710 707 166	
15	Thermocouple	8 747 202 083	
16	Burner assembly washer	8 710 103 060	
17	Gas valve	8 707 011 467	LP
	Gas valve	8 707 011 469	NG
18	Gas supply pipe	8 700 705 464	
19	Electromagnet	8 747 201 094	
20	Electromagnet washer	8 700 103 144	
21	Gas filter	8 700 507 051	
22	Thermocable	8 747 202 078	
23	Thermostat	8 707 206 039	
24	O ring Thermostat	8 700 205 101	
25	O ring Thermostat	8 700 205 041	
26	Water valve assembly	8 707 002 393	
27	Pushrod	8 703 406 204	
28	Water valve diaphragm	8 700 503 050	
29	Slow ignition valve	8 708 503 062	
30	Water valve setting screw	8 703 404 092	
31	O ring setting screw	8 700 205 050	
32	Water valve venturi	8 708 205 235	
33	Water valve piston assembly	8 708 500 230	
34	Water inlet filter	8 700 507 059	
35	Water elbow fitting	8 700 703 114	
36	Water valve set screw	8 703 401 051	

Fig. 12 - Flow chart of Aquastar 125 BS

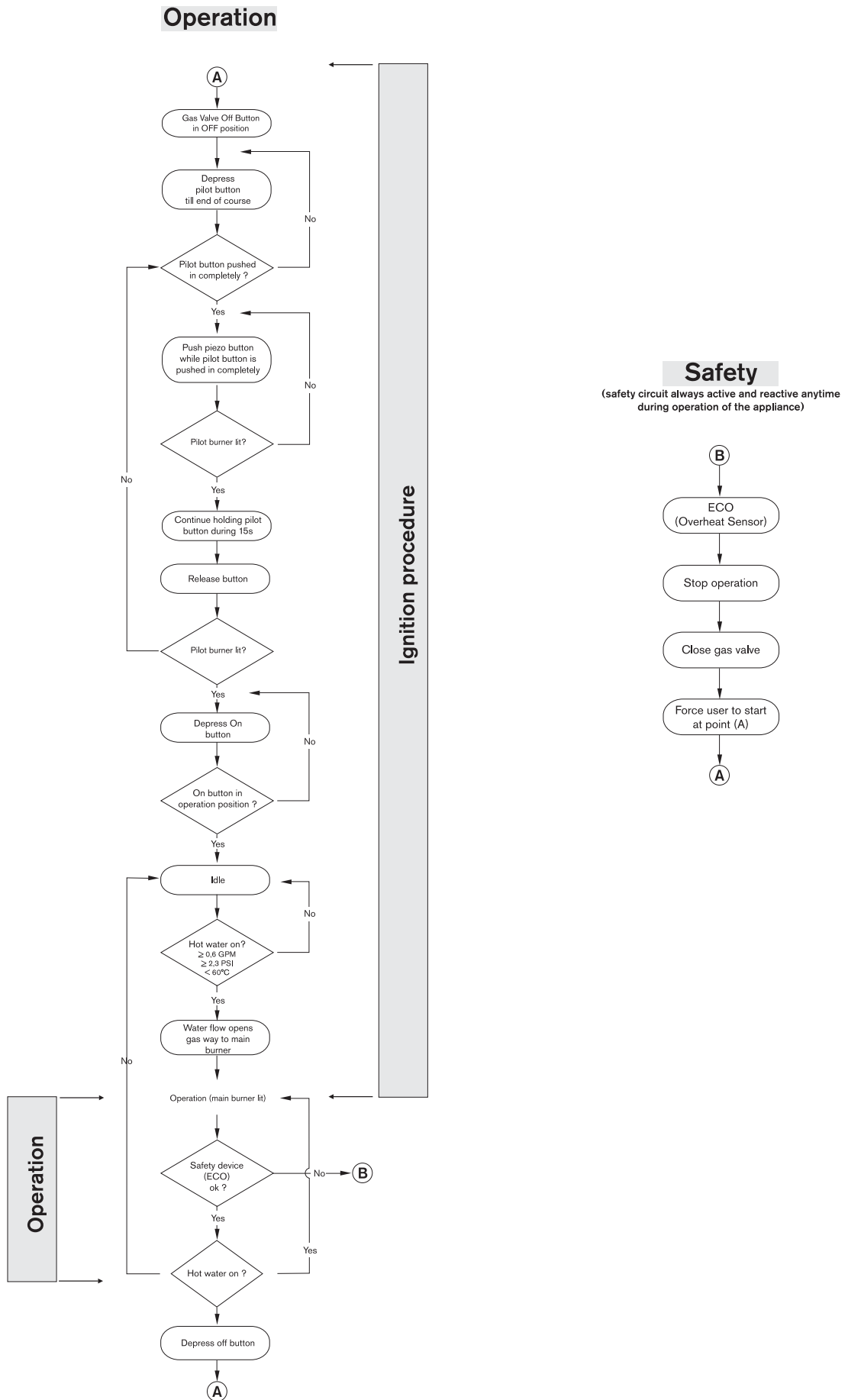

LIMITED WARRANTY

Aquastar

General

Aquastar water heaters are warranted by the Manufacturer (BOSCH) through **BBT North America**. **BBT North America** (BBTNA) will furnish a replacement heat exchanger and will furnish a replacement of any other part which fails in normal use and service within the applicable periods specified below, in accordance with the terms of this warranty. The BBTNA replacement will be warranted for the unexpired portion of the original warranty. This warranty will be valid only for water heaters in possession of the original purchaser as recorded on the warranty card.

The heat exchanger

If the heat exchanger fails within twelve (12) years after the original installation and operation BBTNA will furnish a replacement heat exchanger. However, if the water heater is installed in other than a single family dwelling this heat exchanger warranty is limited to two (2) years from date of original installation and operation.

Exceptions

This warranty will not apply:

1. to defects or malfunctions resulting from failure to properly install, operate or maintain the unit in accordance with the printed instructions provided;
2. to damage or abuse, accident, neglect or freezing and other acts of nature;
3. to damage resulting from operation with either the flame sensor rod or overheat sensor removed;
4. to failure of the heat exchanger resulting from the operation of the water heater in a corrosive atmosphere or at water temperatures exceeding the maximum rating, or if the water heater is not supplied with potable water;
5. to defects or damage cause by any attachment or modification, including any energy-saving device.

All other parts

If any other part fails within two (2) years after original installation and operation, BBTNA will furnish a replacement part free of charge.

Shipping costs

In addition to supplying the replacement part(s), BBTNA will provide ground service delivery for these parts. Expedited or upgraded shipping will be charged to the customer.

Service labor costs

This warranty does not cover any labor costs associated with service, removal or re-installation of part(s). All such costs must be borne by the Purchaser. Additionally, this warranty does not cover any labor costs associated with service, removal or re-installation of the original water heater or a replaced water heater.

How to Make a Claim

Any claim for warranty parts should be made to your local dealer, distributor or to BBTNA. If BBTNA, please contact the Technical Support Department:

BBT NORTH AMERICA
340 Mad River Park
Waitsfield, VT 05673
Phone: 800-642-3111
www.boschhotwater.com

In most cases, the dealer or distributor will be able to promptly honor your claim and subsequently notify BBTNA. However, all replacements are made subject to validation by BBTNA of in-warranty coverage. The damaged or defective item must be made available in exchange for the replacement.

Miscellaneous

No one is authorized to make any other warranties on behalf of BBTNA. It is expressly understood that the replacement warranty of BBTNA shall be in lieu of any and all other warranties, express or implied, including warranties of merchantability or fitness for a particular use or purpose, and further that BBTNA shall not be liable for any loss or damage directly or indirectly arising from the use of the hot water heater, or for any consequential damages arising from such use (including damages from water leakage). BBTNA's sole liability with respect to any defect shall be for the replacement of the defective part(s). Some states do not allow such limitations and exclusions, so the above may not apply to you.

This warranty gives specific legal rights. You may also have other rights which vary from state to state.

MAINTENANCE TABLE see page 13

	EVERY YEAR	EVERY 2 YEARS	EVERY 3-5 YEARS
LUBRICATE WATER VALVE		†	
REBUILD WATER VALVE			†
INSPECT WATER FILTER SCREEN	†		
INSPECT PILOT ASSEMBLY	†		
INSPECT VENT ASSEMBLY	†		
INSPECT MAIN BURNER	†		

Replacement Parts available:

BBT NORTH AMERICA

Bosch Group

Bosch Water heating
 340 Mad River Park
 Waitsfield, Vermont 05673
 Phone 800-642-3111
 Fax (802) 496-6924
www.boschhotwater.com
techsupport@boschhotwater.com

VULCANO Termodomésticos S.A.
Estrada de Cacia
3801 - 856 Aveiro - PORTUGAL