

VACSTAR[®] NEO

DENTAL VACUUM SYSTEM

INSTALLATION AND OPERATION MANUAL

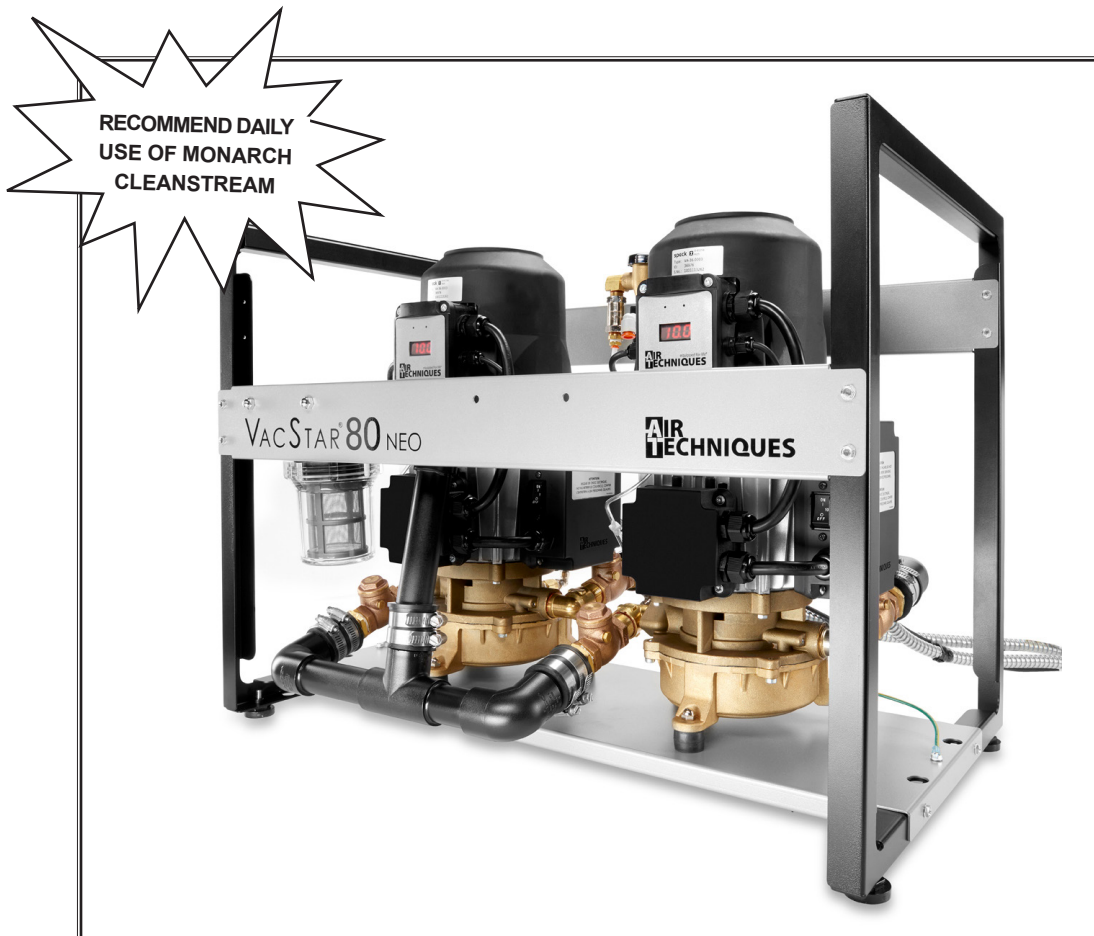

AIR equipped for life[®]
TECHNIQUES

ISO
9001
ISO 13485
FDA-GMP COMPLIANT

TABLE OF CONTENTS

Section	Page
Congratulations	3
Purpose of this Manual	3
Warranty	4
On-Line Warranty Registration	4
Safety Instructions	4
Sizing Guide	5
Optional In-Line Filter Kit	5
Operating Information	5
Product Specifications/Dimensions	6
Site Requirements	6
Key Parts Identification - Single Pump	8
Key Parts Identification - Twin Pumps	8
Installation Information	9
System Vacuum Adjustment	13
Maintenance	14
Replacement/Reorder	17
Accessories/Options	17
Troubleshooting	18

LIST OF ILLUSTRATIONS

Figure	Title	Page
1	VacStar NEO Models	3
2	VacStar 20 and 40 NEO Parts Location	8
3	VacStar 50 and 80 NEO Parts Location	8
4	VacStar NEO Water Inlet Connection	9
5	VacStar NEO Operatory Suction Connection	9
6	Changing VacStar 50 and 80 NEO Operatory Suction Connection Side	10
7	Exhaust Drain Connection	11
8	Changing VacStar 50 and 80 NEO Drain Connection Side	12
9	VacStar NEO Electrical Connections	12
10	Digital Display Front Panel	13
11	Clean Stream Dispenser Cap Adaptor Locations	14
12	Intake Solids Collector Location	15
13	Water Inlet Strainer Location	16

Congratulations on the purchase of your new **VacStar NEO** Dental Vacuum System hereafter referred to as **VacStar NEO** in this manual.

Your **VacStar NEO** has been engineered to deliver maximum air flow at the ideal vacuum level without creating traumatic suction pressure that could harm patients' delicate tissue. The **VacStar NEO** is a water ring pump that produces consistent high-volume air flow, even with multiple users. The balanced, corrosion free bronze impeller minimizes noise while the intelligent digital electronics monitors and maintains constant uniform vacuum pressure and flow. A three phase induction motor, with Variable Frequency Drive (VFD) control, can be depended on to start every time. The **VacStar NEO** is designed with everything accessible to make installation quick and maintenance easy.

Each **VacStar NEO** has an extremely efficient axial flow impeller and housing design that minimizes water consumption. The built-in Variable Frequency Drive (VFD) control maintains efficient use of electricity. Additionally, an in-line muffler is included to dampen noise during operation.

An Air/Water Separator is available to separate the discharged liquid and gas from the operatories. The gases are vented out while the liquid and its particulates are directed down the drain.

Thousands of dentists have depended on the **VacStar**[®] since 1987. Now that your practice has a **VacStar NEO** you too can depend on constant, uniform delivery of vacuum to your operatories and proven trouble-free operation.

PURPOSE OF THIS MANUAL

This manual provides installation, operation and maintenance instructions for the support of the four available **VacStar NEO** systems comprising two single pump models and two twin pump models shown below. Review and follow the guidelines included in this manual to ensure that the system provides the highest level of service.



Single Pump Models

- VS20NEO** - 2 User Capability
- VS40NEO** - 3 User Capability

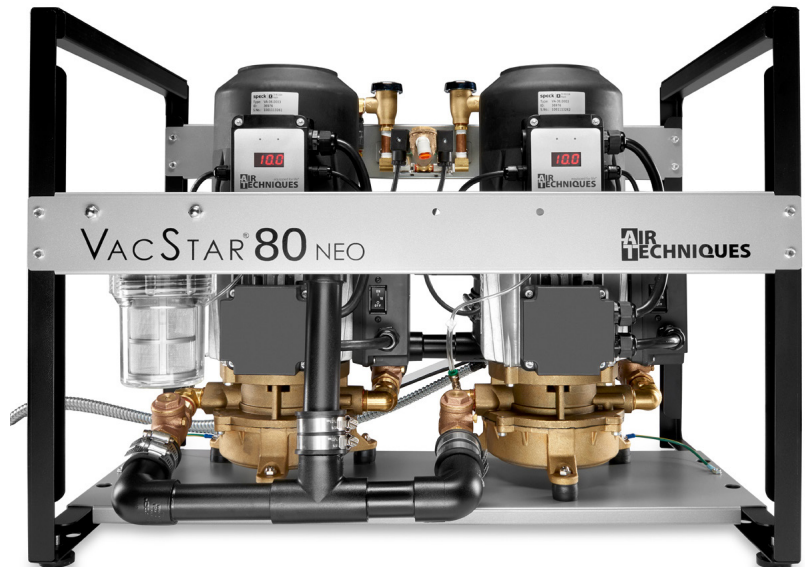

Twin Pump Models

- VS50NEO** - 4 User Capability
- VS80NEO** - 7 User Capability

Figure 1. VacStar NEO Models

WARRANTY

VacStar NEO is warranted to be free from defects in material and workmanship from the date of installation for a period as follows:

- Standard Warranty: 2 years (24 months) on complete unit.
- Extended Warranty: 5 years (60 months) all pumps and motors.

All part and component returns and replacement equipment under warranty require a Return Materials Authorization (RMA). Warranty returns must be received within three months of the RMA issue date. Items returned without an RMA, or included with other products for which an RMA has been issued, may be returned to the customer at the discretion of Air Techniques, Inc.

Any item returned under warranty, will be repaired or replaced at our option at no charge provided that our inspection shall indicate it to have been defective. Air Techniques, Inc. is not liable for indirect or consequential damages or loss of any nature in connection with this equipment. Dealer labor, shipping and handling charges are not covered by this warranty.

Warranty credit will not be applied to product returns that exhibit damage due to shipping, misuse, careless handling or repairs by unauthorized personnel. Credit, or partial credit, will not be issued until products/parts have been received and assessed. Warranty is void if product is installed or serviced by anyone other than an authorized Air Techniques' dealer or service personnel.

This warranty is in lieu of all other warranties expressed or implied. No representative or person is authorized to assume for us any liability in connection with the sale of our equipment.

ON-LINE WARRANTY REGISTRATION

Quickly and easily register your new **VacStar NEO** on-line. Just have your product model and serial numbers available. Then go to the Air Techniques' website, www.airtechniques.com, click the **warranty registration** link and complete the registration form. This on-line registration ensures a record for the warranty period and helps Air Techniques keep you informed of product updates and other valuable information.

SAFETY INSTRUCTIONS

Use of the **VacStar NEO** not in conformance with the instructions specified in this manual may result in permanent failure of the unit.

WARNING: To prevent fire or electrical shock, do not expose this equipment to rain or moisture.

All user serviceable items are described in the maintenance section.

Manufacturing date code on serial number label is in the format Month YYYY.

ATTENTION USERS:



Alerts users to important Operating and Maintenance instructions. Read carefully to avoid any problems.



Warns users that uninsulated voltage within the unit may be of sufficient magnitude to cause electric shock.

I ON
O OFF

Indicates the ON and OFF position for the Equipment power switch.



MEDICAL ELECTRICAL EQUIPMENT

WITH RESPECT TO ELECTRICAL SHOCK, FIRE, MECHANICAL AND OTHER SPECIFIED HAZARDS ONLY
IN ACCORDANCE WITH UL-60601-1, CAN/CSA C22.2 NO.601.1
66CA



Indicates protective Earth Ground for the Equipment power switch.

Choosing the correct size **VacStar NEO** for your practice depends on the number of HVE (High Volume Evacuator) and SE (Saliva Ejector) users anticipated. To assure optimum vacuum, the vacuum demands should not exceed the number of HVE and SE users shown in the chart below:

Recommended Number of Simultaneous Users

VacStar 20 NEO HVE's + SE's	VacStar 40 NEO HVE's + SE's	*VacStar 50 NEO HVE's + SE's	*VacStar 80 NEO HVE's + SE's
2 + 0	3 + 0	4 + 0	7 + 0
1 + 1	2 + 2	3 + 2	6 + 1
0 + 4	1 + 4	2 + 4	5 + 3
	0 + 6	1 + 5	4 + 4
NOTES: HVE = High Volume Evacuator SE = Saliva Ejector * These combinations apply if both pumps are running together. If only one pump is running, use the Sizing Guide for VacStar 20 or 40 NEO.			3 + 6
			2 + 8
			1 + 10
			0 + 13

OPTIONAL IN-LINE FILTER KIT

Since larger quantities of particulates may occur initially when a **VacStar NEO** is replacing another vacuum pump, an optional In-Line Filter is recommended to be installed at the intake connection (see ACCESSORIES/OPTIONS). This In-Line Filter is designed to collect larger quantities of particulates from the operatories BEFORE it flows into the VacStar NEO. The larger quantities of debris is mainly due to the VacStar NEO's increased pulling power and the effectiveness of the CleanStream Evacuation System Cleaner's ability to break down proteinaceous deposits and synthetic debris that have accumulated in the existing vacuum lines.

Use the In-Line Filter Kit P/N 55078 for single vacuum pump units VS20NEO and VS40NEO. The kit part number for twin pump units (VS50NEO and VS80NEO) is 55079. Refer to the Maintenance Section for recommended maintenance requirements.

OPERATING INFORMATION

■ **AT THE START OF THE DAY**

Always TURN ON THE WATER before TURNING ON THE POWER.

- The VacStar NEO may be turned on/off from a single, convenient location within the dental suite using a Remote Control Panel (See Optional Accessories).
- The vacuum level is factory preset at 10 In Hg (inches of mercury). This is the reading displayed on the front panel when all HVE's (High Volume Evacuator) and SE's (Saliva Ejector) are CLOSED. Should this setting be too high for your needs, contact your dealer to readjust the setting.
- It is recommended that the system run continuously during the day. However, the VacStar NEO can be turned off if suction is not required for a period of 15 minutes or longer. The VacStar NEO runs only as fast as required. When the vacuum demand is low, it slows down. Then it speeds up when the demand is high.
- If one pump is being operated at a time, it is important to alternate pumps on an every other day schedule so that the pumps are used evenly.

■ **AT THE END OF THE DAY**

Perform Daily Vacuum Line Maintenance procedure.
 Always TURN THE POWER OFF, then TURN THE WATER OFF.

PRODUCT SPECIFICATIONS/DIMENSIONS

Spec/Dimension	VacStar NEO Models											
	VS20NEO			VS40NEO			VS50NEO			VS80NEO		
ELECTRICAL												
Voltage Rating	220			220			220			220		
Voltage Minimum/Maximum	198/242			198/242			198/242			198/242		
Full Load Amps	10			14			20			28		
Frequency Single Phase (Hz)	50/60			50/60			50/60			50/60		
WATER												
Inlet Water Pressure (PSI)	20 - 100			20 - 100			20 - 100			20 - 100		
Flow Rate Per Pump (gallon/minute)	0.13			0.13			0.13			0.13		
Water Temperature (°F)	40 - 75			40 - 75			40 - 75			40 - 75		
VACUUM LEVEL Preset at Factory (In Hg)	10			10			10			10		
MINIMUM AIRFLOW (SCFM @ 0 In Hg)	15			20			30			40		
SHIPPING WEIGHT (lbs)	75			75			175			175		
DIMENSIONS Inches	H	W	D	H	W	D	H	W	D	H	W	D
	19	11	11	19	11	11	23	28	18	23	28	18

SITE REQUIREMENTS

Environment Conditions:

Operating Conditions

Indoor use at altitudes up to 2000 m (6500 ft)

Temperature 5 to 40° C (41 to 104° F).

Maximum relative humidity 80% for temperatures up to 31° C (85° F), decreasing linearly to 50% relative humidity at 40° C (104° F).

Supply voltage fluctuation of +/- 10% of nominal voltage.

IEC 60601-1 Classification

Not suitable for use in the presence of a flammable anesthetics mixture with air or with oxygen or nitrous oxide.

Class I Installation Category

Ordinary equipment (IPXO). Does not protect against ingress of water.

Unit is suitable for continuous operation.

SITE REQUIREMENTS

Requirement	VacStar NEO Models			
	VS20NEO	VS40NEO	VS50NEO	VS80NEO
ELECTRICAL				
Minimum Panel Breaker Rating	15A	20A	2 ea. 15A or 1 @ 30A	2 ea. 20A or 1 @ 40A
Wire Size AWG (Minimum Gauge)	14	12	2 ea. #14 or 1 @ #10	2 ea. #12 or 1 @ #8
PLUMBING				
Minimum CFM @ 0 In Hg	18	25	36	50
Air Exhaust	2" schedule 40 pipe	2" schedule 40 pipe	2" schedule 40 pipe	2" schedule 40 pipe
Ambient Temperature	40 - 104°F (5 - 40°C)	40 - 104°F (5 - 40°C)	40 - 104°F (5 - 40°C)	40 - 104°F (5 - 40°C)
<u>Overhead Plumbing</u>				
Main Line Minimum/Maximum Inside Diameter (inches)	1 / 1½	1¼ / 2	1¼ / 1½	1½ / 2
End Fitting Maximum	¾" FNPT	¾" FNPT	1" FNPT	1" FNPT
Riser Diameter Overhead Main Line	½" ID	½" ID	½" ID	½" ID
<u>Floor Plumbing</u>				
Main Line Minimum/Maximum Inside Diameter (inches)	1 / 1½	1¼ / 2	1¼ / 1½	1½ / 2
End Fitting Maximum	¾" FNPT	¾" FNPT	1" FNPT	1" FNPT
Branch Line Diameter Minimum/Maximum Inside Diameter (inches)	¾ / 1½	1 / 1½	1 / 1½	1 / 1½

NOTE: Suction piping must slope at least a ¼" for each 10 feet of run towards the pump. Use PVC Schedule 40 or Copper Type M.

ALL INSTALLATIONS MUST CONFORM TO LOCAL CODES

KEY PARTS IDENTIFICATION - SINGLE PUMP

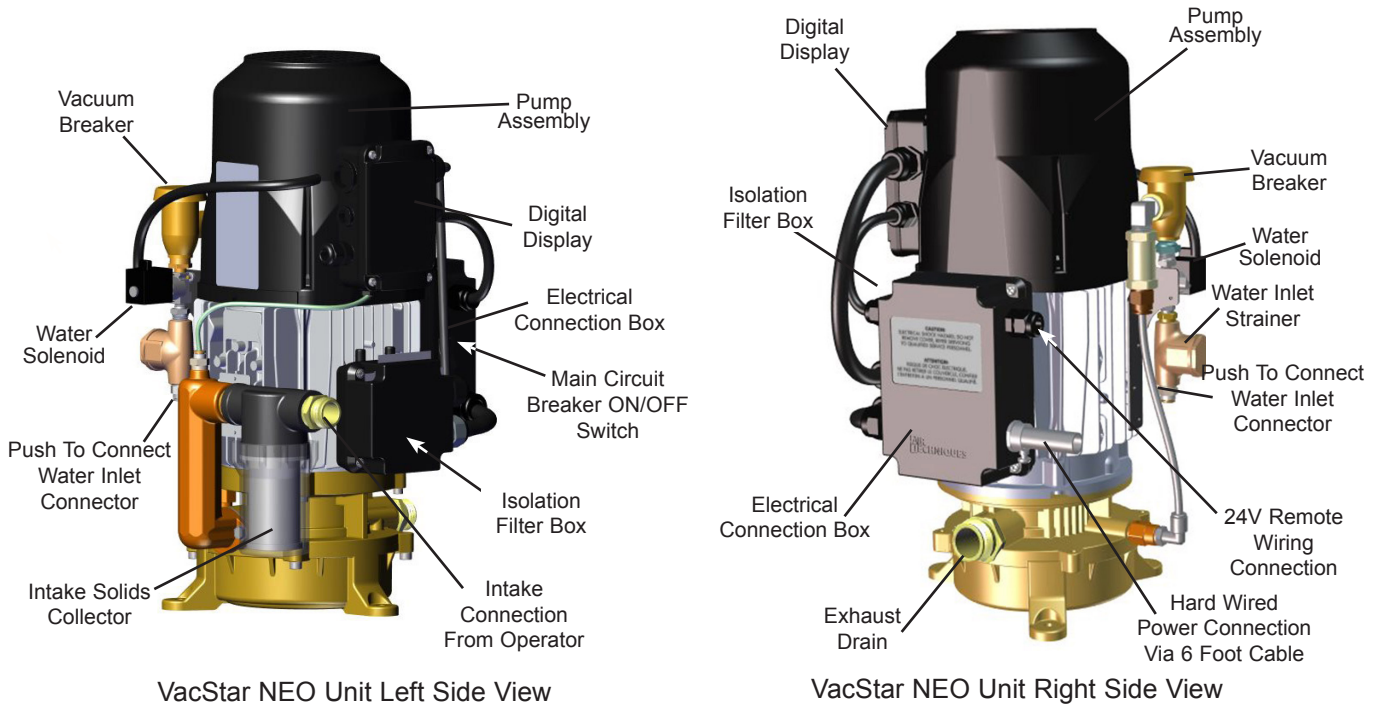

Figure 2. VacStar 20 and 40 NEO Parts Location

KEY PARTS IDENTIFICATION - TWIN PUMPS

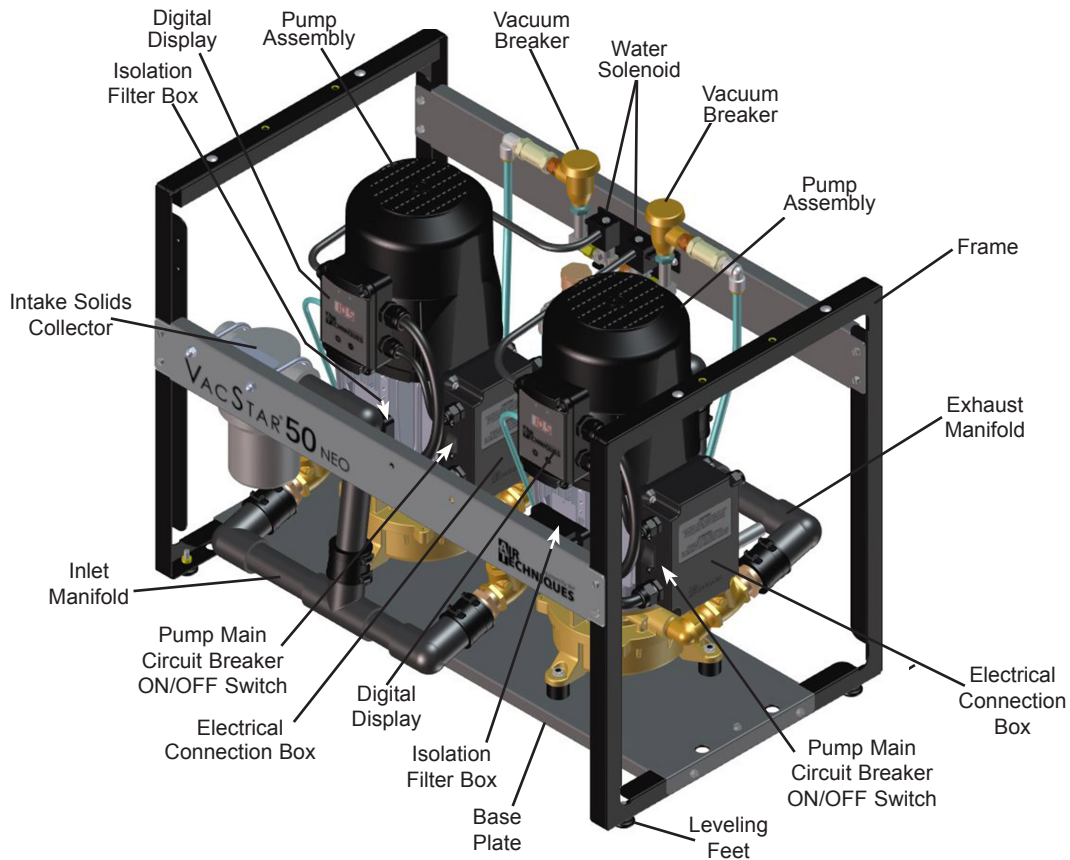
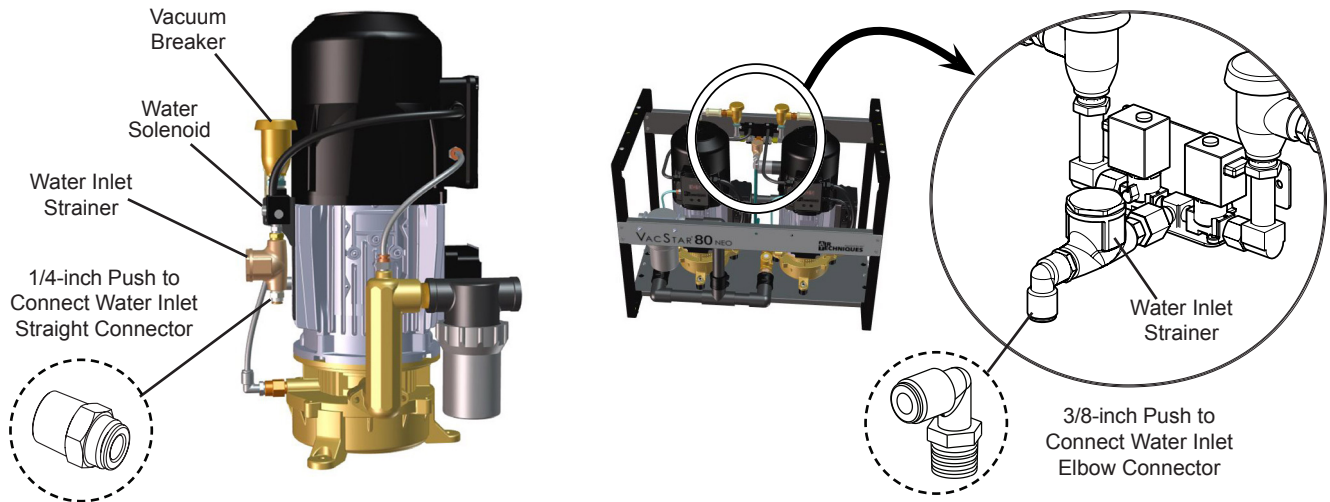

Figure 3. VacStar 50 and 80 NEO Parts Location

■ Plumbing (water) lines

- To assure that the **VacStar NEO** provides optimum vacuum, incoming water pressure must be maintained between 20 and 100 psi.
- If heavy combinations of particulates exist in the incoming water, an in-line filter should be installed. (See Accessories/Options for the Remote Control Water Valve.) This will prevent the VacStar NEO's water inlet strainer from clogging too frequently.
- Incoming water temperature should be between 4°C and 24°C (40 and 75°F.)
- Water connection location is shown by Figure 4, Water Inlet Connection.



VacStar 20 and 40 NEO Water Connection

VacStar 50 and 80 NEO Water Connection

Figure 4. VacStar NEO Water Inlet Connection

■ Suction

- Refer to Figure 5 and connect the suction hose from the operator to the suction intake of the intake solids collector assembly of the associated VacStar NEO system.

NOTE: VacStar 50 & 80 NEO systems are shipped with the suction intake connector facing left (looking straight at the front of the unit). When the installation requires the connection on the right side, perform the Reposition Suction Intake Connection Procedure provided on the next page.

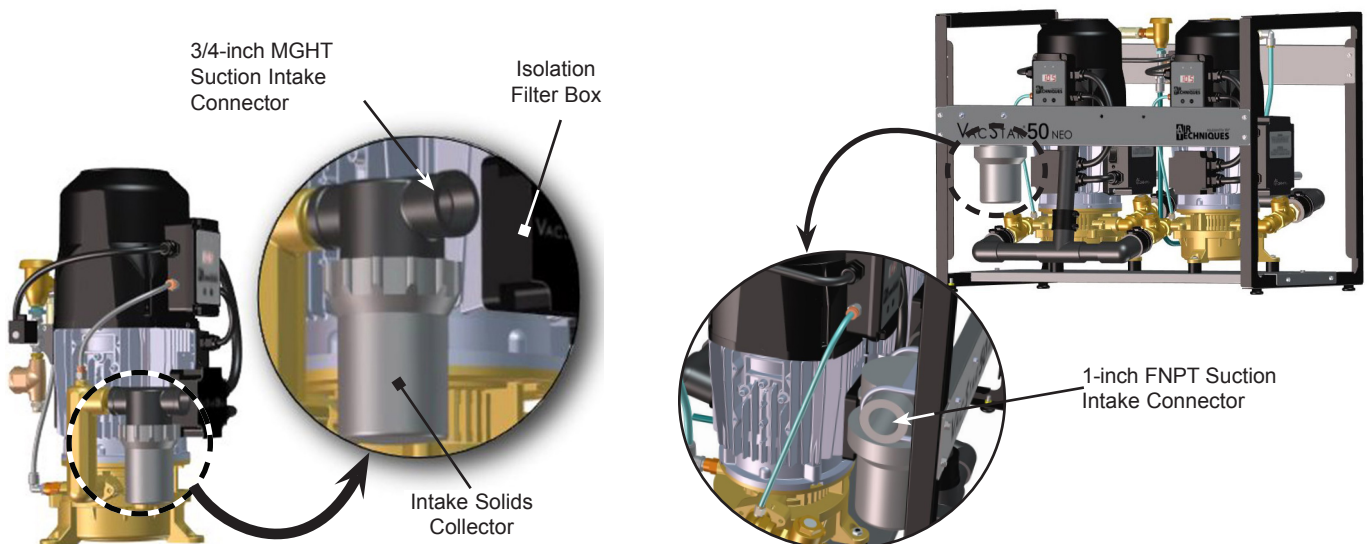

VacStar 20 and 40 NEO Suction Connection

VacStar 50 and 80 NEO Suction Connection

Figure 5. VacStar NEO Operatory Suction Connection

INSTALLATION INFORMATION

Reposition Suction Intake Connection Procedure

1. Loosen the no hub coupling securing the intake section to the Inlet Manifold.
2. Remove the acorn nuts from the J-hook bolts securing the Solids Collector and lift the intake section from Inlet Manifold as shown below.
3. Rotate intake section to face right and insert intake section into the Inlet Manifold.
4. Secure the Solids Collector in position with the J-Hook bolts and acorn nuts.
5. Secure the intake section to the Inlet Manifold by tightening the no hub coupling.

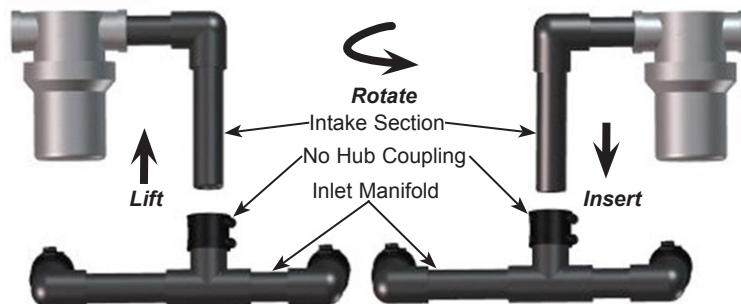
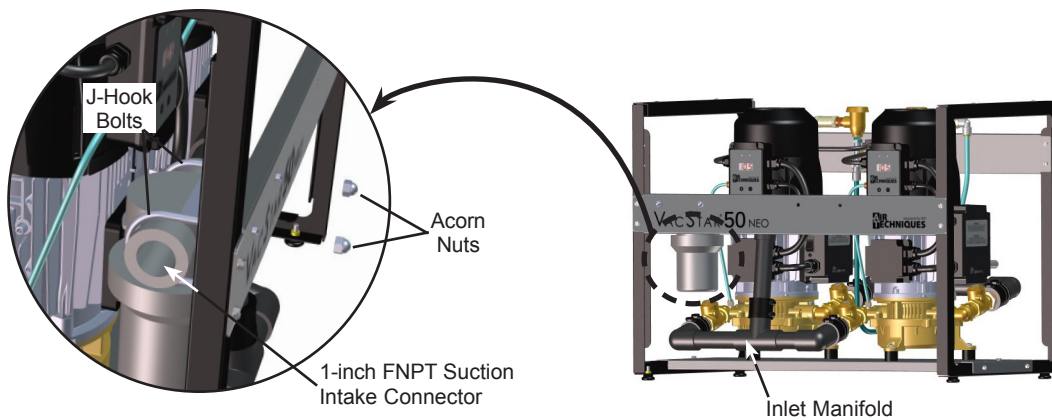
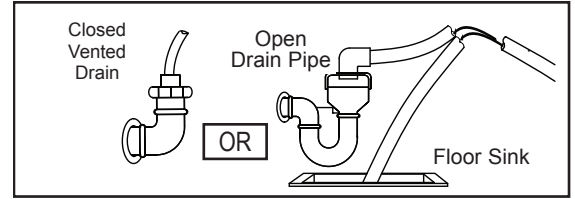

Figure 6. Changing VacStar 50 and 80 NEO Operator Suction Connection Side

■ Drain line

- As shown by the Drain Configuration Detail, use an open drain pipe (1 ½ inch P-Trap with 1 inch air gap or floor sink) or a closed vented drain for the removal of waste liquids from the **VacStar NEO**.
- The drain may be up to 36 inches above the unit.



Drain Configuration Detail

- Refer to Figure 7 and connect the exhaust hose between the associated **VacStar NEO** system and the facility drain by performing the drain connection procedure for the system being installed.

NOTE: VacStar 50 & 80 NEO systems are shipped with an in-line muffler installed on the exhaust manifold with the drain connector facing right (looking straight at the rear of the unit). When the installation requires the connection on the left side, perform the Reposition Exhaust Drain Connection Procedure provided on the next page.

Mufflers provided with VacStar 20 & 40 NEO systems must be installed on site in the exhaust line.

VacStar 20 & 40 NEO Drain Connection

1. Connect the exhaust hose between the exhaust drain connector and the facility drain.
2. Cut the exhaust hose at a convenient location.
3. Install each cut end of the hose to the muffler input and output.
4. Make sure the hose is not bent or kinked and that all connections are secure.

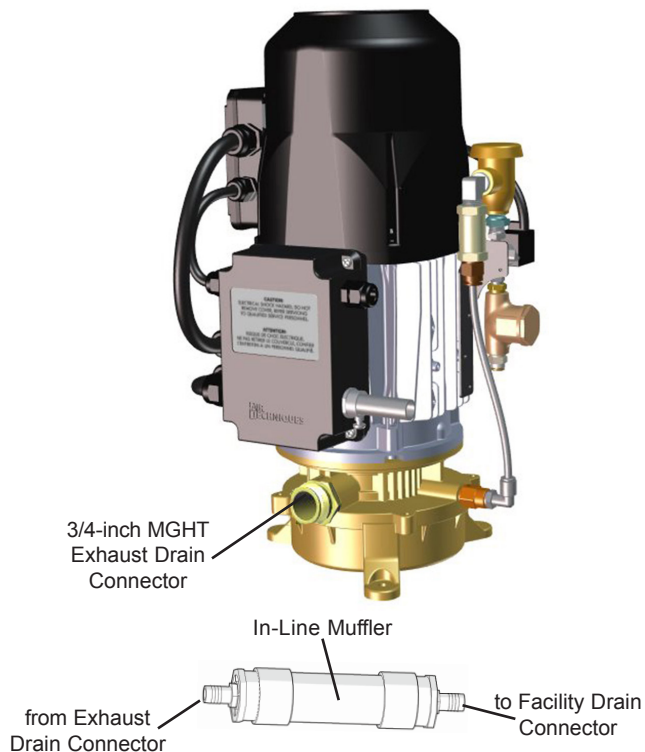

VacStar 20 and 40 NEO Drain Connection

VacStar 50 & 80 NEO Drain Connection

1. Connect the exhaust hose between the muffler output and the facility drain.
2. Make sure the hose is not bent or kinked and that all connections are secure.

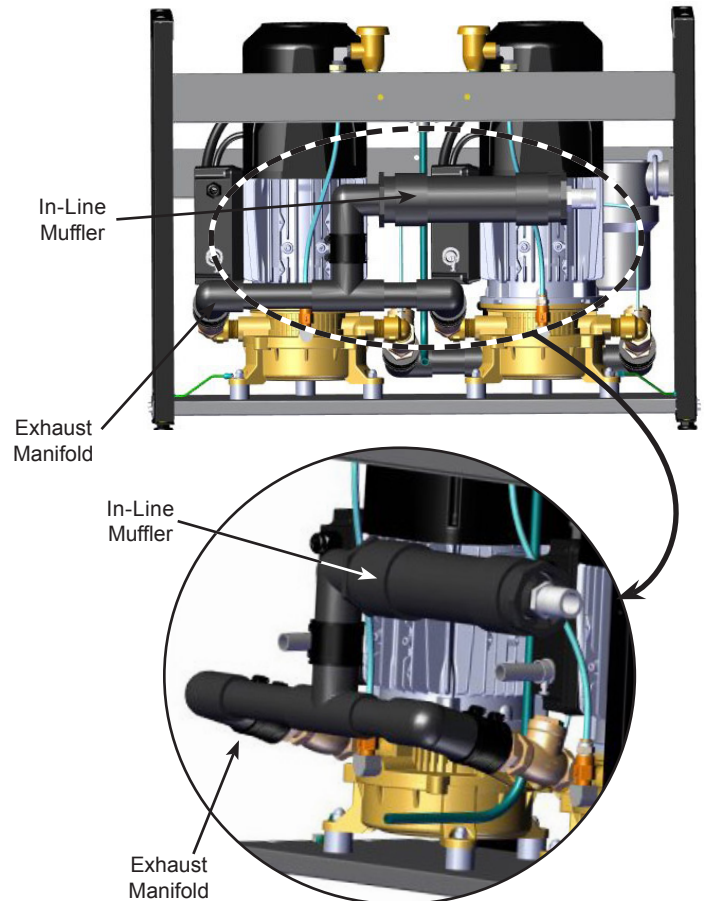

VacStar 50 and 80 NEO Rear Drain Connection

Figure 7. Exhaust Drain Connection

INSTALLATION INFORMATION

Reposition Exhaust Drain Connection Procedure

1. Loosen the no hub coupling securing the in-line muffler to the Exhaust Manifold.
2. Lift the in-line muffler from Exhaust Manifold as shown below.
3. Rotate the in-line muffler to face left.
4. Insert the in-line muffler into the Exhaust Manifold.
5. Secure the in-line muffler to the Exhaust Manifold by tightening the no hub coupling.

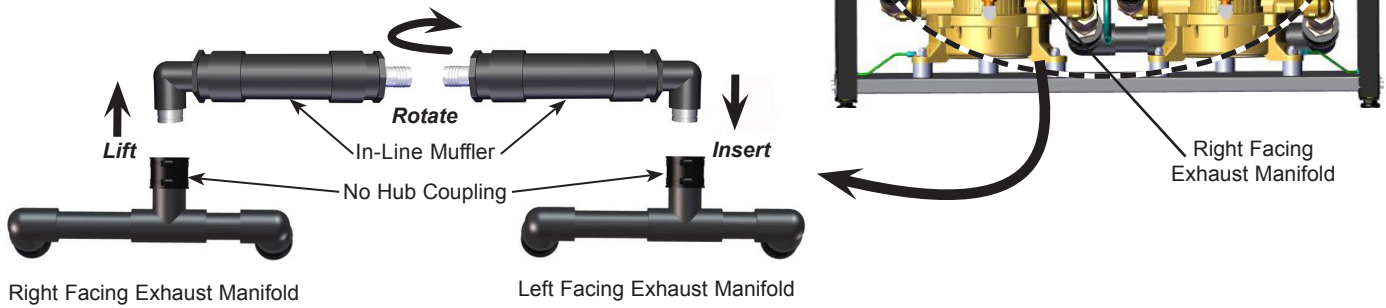
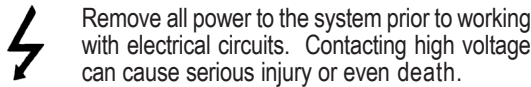

Figure 8. Changing VacStar 50 and 80 NEO Drain Connection Side

Important: Each pump should have a dedicated circuit panel.



All systems must be wired directly from an electrical box that complies with local electrical codes.

■ Electrical

- 220VAC Connections:

- Each pump has its own 6-foot BX cable pre-wired to the electrical connection box for direct wiring to dedicated 220VAC, single phase 50/60 Hz circuit via a disconnect box with approved ground. See page 7 for branch circuit size.
- Single pump models need one connection, while twin pump models require two connections.
- Disconnect boxes should be mounted no more than 3 feet of each other and 3 feet of installation center line.
- Figure 9 shows the wiring of the electrical BX cable used to connect each pump directly to facility input power.
- The supplied cable is pre-wired in the electrical box of each pump. Connect cable wires by matching color.

Important: When not connecting a 24VDC remote switch, the ORG and YEL wires must be tied together and the BRN wire insulated for pump operation.

- 24VDC Connections:

- 24VDC Connections are used when installing a 24VDC remote switch. They are made via a supplied interconnect cable that is also pre-wired to the electrical connection box of each pump.
- Make the 24VDC connections shown below for the remote switch. When not using the remote switch, insulate the BRN wire and tie the ORG and YEL wires together.

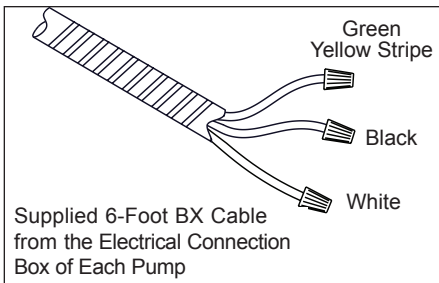

230VAC Connections

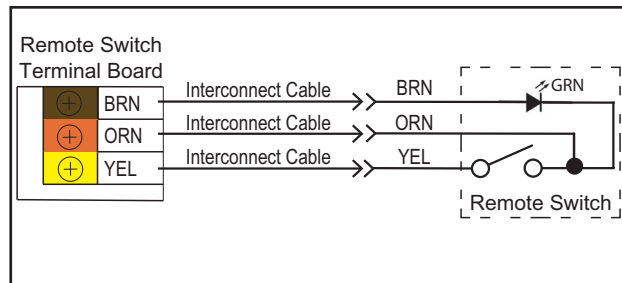

24VDC Connections

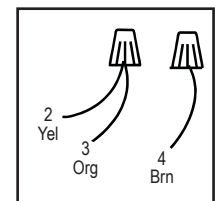

Connection without 24VDC Switch

Figure 9 VacStar NEO Electrical Connections

SYSTEM VACUUM ADJUSTMENT

Important: Make sure to set both pumps of a twin **VacStar NEO** system to the same vacuum level.

- **Vacuum Adjustment.** The operating vacuum level of each **VacStar NEO** pump can be adjusted to a value between 8.0 and 14.5 In Hg depending on user preference.

Refer to Figure 10 and set the pump to the desired operating vacuum level (up or down) by performing the following steps.

1. Press and hold both the Increase Select and Decrease Select buttons for five seconds.
2. Release both buttons and observe that the digital display flashes showing the current vacuum level.
3. Using either the Increase Select or Decrease Select button, set the pump to the desired operating vacuum level (up or down).
4. Observe that the pump resumes operation at the new vacuum level setting when no further button presses are detected.

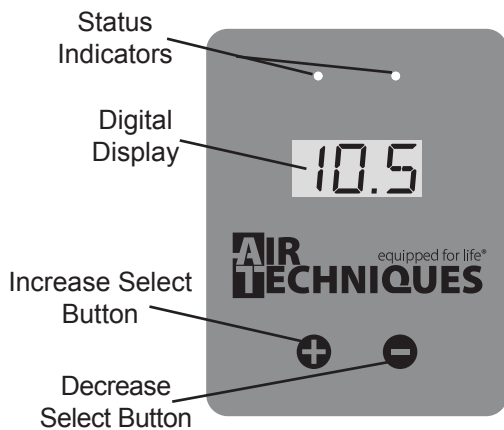

Item	Function
Digital Display	A 3-character digital display that shows the following information: <ol style="list-style-type: none"> 1. Current operating vacuum level. 2. Error codes. (See Troubleshooting.) 3. Flashes to denote vacuum setting process.
Increase Select Button	A membrane keypad switch that allows the user to manually increase the vacuum level setting to a value between 8.0 and 14.5 In Hg in 0.5 In Hg increments as necessary. Also scrolls through error codes as described in Troubleshooting.
Decrease Select Button	A membrane keypad switch that allows the user to manually decrease the vacuum level setting to a value between 8.0 and 14.5 In Hg in 0.5 In Hg increments as necessary. Also scrolls through error codes as described in Troubleshooting.
Status Indicators	LED indicator lamps that show system status as follows: <p>Normal operation: Right indicator lit Green. Left indicator not lit.</p> <p>Error indication: Left indicator lit Red. Right indicator not lit. Refer to Troubleshooting.</p>

Figure 10. Digital Display Front Panel

MAINTENANCE

Like all precision products, your **VacStar NEO** requires a certain amount of care on a regularly scheduled basis. A well-organized maintenance program aids dependable equipment operation and reduces problems to a minimum. Routine checks help to detect general overall wear, and replacement of parts can often be made before a problem occurs. Consequently, we have established minimum maintenance requirements listed below that include routine inspections and the replacement of filters. Adherence to this recommended maintenance schedule will ensure that the equipment will continue performing at its best with uninterrupted service.

■ Daily Maintenance - Clean vacuum lines

Flush all vacuum lines and tubing in the dental system with Monarch CleanStream Evacuation System Cleaner.

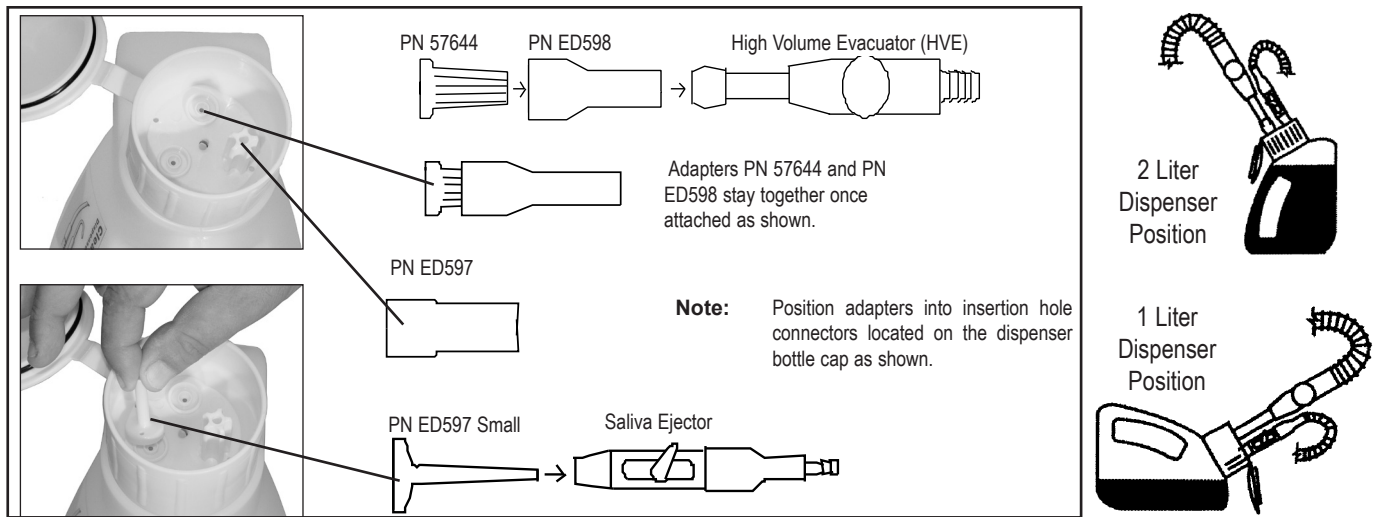

Figure 11. CleanStream Dispenser Cap Adaptor Locations

■ Routine Inspection - Monthly

1. Check tubing for kinks or cracks.
2. Check for abnormal noises and leaks.
3. Twin Units: Make sure both motors are running
4. Check exterior surfaces for dirt and debris, clean if necessary.
5. Make sure that no flammable, corrosive, or combustible materials are stored in the equipment room (especially in the area around the equipment).

Caution: Solids collector may contain biologically hazardous material. Wear protective gloves. Dispose of waste in accordance with local and federal regulations.

Important: When a VacStar NEO is replacing another vacuum pump, clean the collector DAILY during the first week of operation since larger quantities of particulates may initially occur.
A worn or missing gasket and/or failure to tightly screw the bowl to the solids collector body will cause poor suction due to air leakage.

DO NOT OPERATE THE VACSTAR NEO WITHOUT THE SCREEN INSIDE THE FILTER BOWL.

■ **Intake Solids Collector Replacement - Monthly**

Refer to Figure 12 and using the replacement kit listed below for the specific **VacStar NEO** models, replace the solids bowl, screen and gasket. Do the same replacement if using an optional in-line filter.

VacStar NEO Model	Solids Collector Kit Part No.	Optional In-Line Filter Kit Part No
VS20NEO & VS40NEO	55880	55094
VS50NEO & VS80NEO	55094	55094

Replacement Procedure

1. Turn off the power and water supply.
2. Unscrew the solids bowl (counter clock-wise) and remove the screen and gasket. Dispose of all three items.
3. Assemble a new bowl, screen and gasket included in the Solids Collector Replacement Kit.
4. Install the new solids collector by screwing the bowl into the solids collector body.

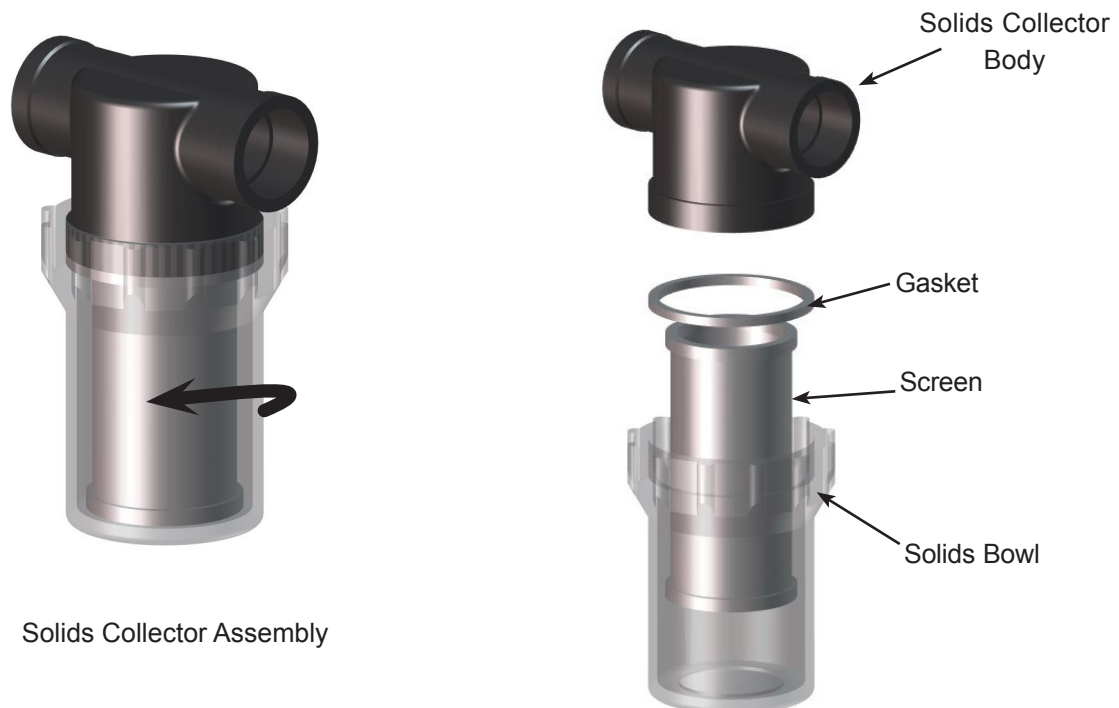

Figure 12. Intake Solids Collector Location

MAINTENANCE

■ Check/Clean Solenoid Water Inlet Strainer - Semi-Annually

Check the Inlet Strainer for dirt and debris by performing the following steps.

1. Turn off the power and water supply to the equipment.
2. Use a 1 3/16 inch wrench to unscrew (turn counter clockwise) the cover nut.
3. Remove the cover nut and strainer.
4. Inspect the strainer and clean as necessary.

VacStar 50 & 80 NEO

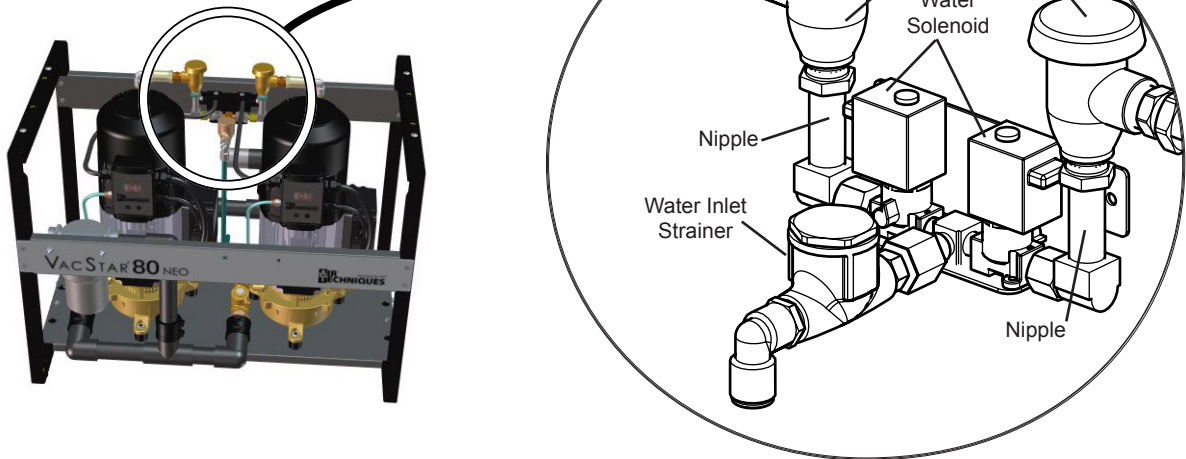

VacStar 20 & 40 NEO

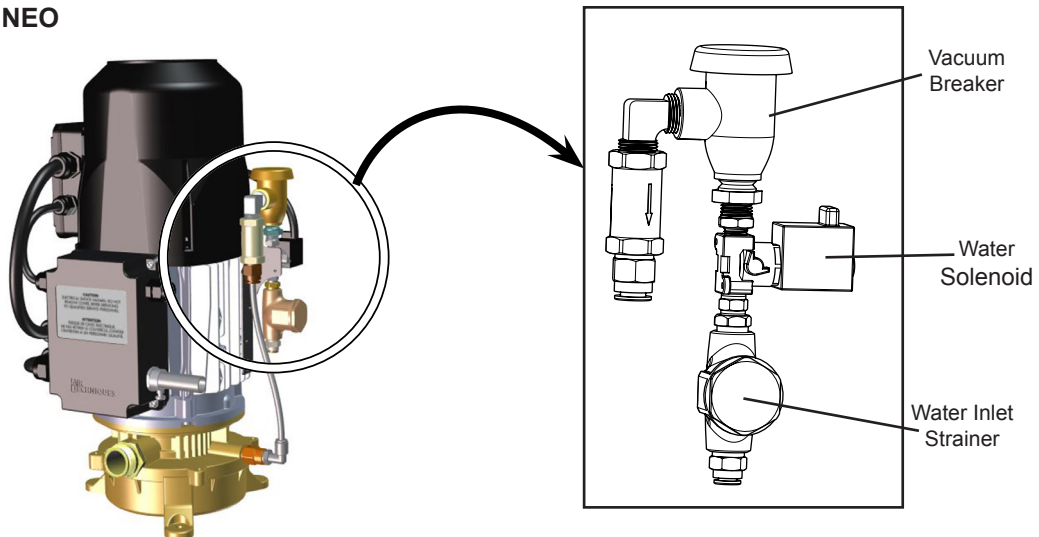

Assembling the Water Inlet Strainer (All Models)

1. Orienting the assembly with the cover nut facing down as shown, seat strainer into the cover nut.
2. Insert the strainer up into the strainer body and tighten the cover nut.
3. Make sure the strainer stays perpendicular to the strainer body.
4. Push up and tighten the cover nut making sure not to over tighten.

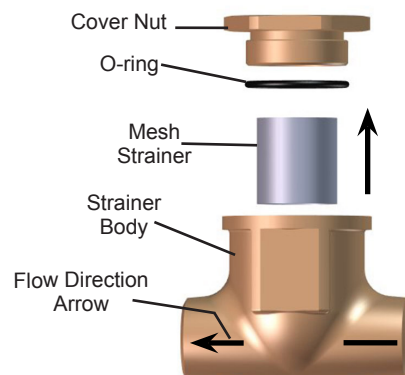

Figure 13. Water Inlet Strainer Location

REPLACEMENT/REORDER

Description	Model	Part Number
Solids Collector Replacement Kit	VacStar 20 & 40 NEO	55880 (3/4 inch)
	VacStar 50 & 80 NEO	55094 (1 inch)
Optional In-Line Filter Replacement Kit	All VacStar NEO Models	55094

ACCESSORIES/OPTIONS

The following lists the description, part number, the applicable model and description for accessory components and options available to maintain and expand the **VacStar NEO** System to meet your professional needs. Contact your Air Techniques Dealer for information.

Description	Model	Part Number	
Remote Control Panels with 24V switches	VacStar 20 & 40 NEO	53250 or 53251	
	VacStar 50 & 80 NEO	53113 or 53149	
Remote Control Water Valve, with filter	All VacStar NEO Models	53020 (24V) - 3/4" pipe	53020-1 (115V) - 3/4" pipe
		53170 (24V) - 1" pipe	53171 (115V) - 1" pipe
In-Line Filter Kit	VacStar 20 & 40 NEO	55078 - 3/4" pipe	
	VacStar 50 & 80 NEO	55079 - 1" pipe	
CleanStream Evacuation System Cleaner	All VacStar NEO Models	57660 Starter Kit	
		57640 1 Box of 32 Packets	
Air/Water Separator	All VacStar NEO Models	55540	

TROUBLESHOOTING

Error Reporting. To protect itself from potentially damaging conditions, each **VacStar NEO** monitors its system operation and immediately records and reports any errors found. Some errors clear automatically as soon as the operating issues are resolved; other errors have to be manually reset. The tables below list all currently active fault indications via System Status Indicators and Error Codes.

An additional list of faults during operation is also provided. This table lists the problem, possible cause, and possible solutions to observed anomalies with system operation. The types of errors reported along with possible causes should be forwarded to your Air Techniques dealer for corrective action, affects on the system and details on how the error can be reset.

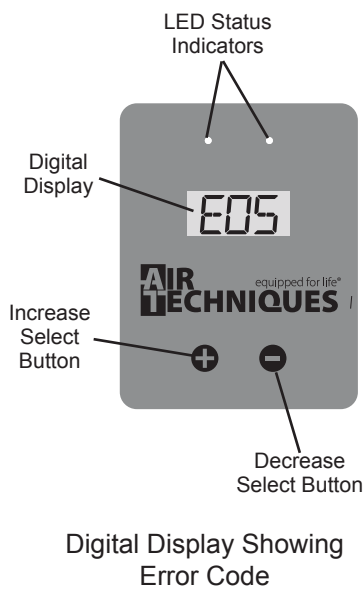

System Status Indicator	Operational Condition
<ol style="list-style-type: none"> All LED status indicators extinguished. Digital display extinguished. 	No power to unit
<ol style="list-style-type: none"> Right LED status indicator blinks green. Left LED status indicator extinguished. Digital display shows vacuum level, usually 0.0. 	Power to unit, not running
<ol style="list-style-type: none"> Right LED status indicator illuminates solid green. Left LED status indicator extinguished. Digital display shows vacuum level. 	Power to unit, running
<ol style="list-style-type: none"> Right LED status indicator extinguished. Left LED status indicator illuminates solid red Digital display shows Err then the code as an E with an one or two digit numeral as shown. Pressing the increase select (+) button or the decrease select (-) button on the front panel cycles through any additional error codes and displays as E##. 	Power to unit, Error condition

Error Code	Error Description	Error Code	Error Description
E0	Motor PTC open (See note.)	E12	DC Link voltage disturbance
E1	Motor PTC short	E13	Motor current too high
E2	Motor PTC over temperature	E14	Motor current too high
E3	Power module over temperature	E16	Over voltage protection not working
E4	Motor short circuit or over current detection in power module	E17	Input phase fault
E5	Rectifier over temperature	E18	Parameter error
E8	Input voltage too low	E19	Analogue Input out of range
E9	Input voltage too high	E20	Motor current too high
E10	DC Link voltage too low	E31	Global Error indication
E11	DC Link voltage too high		

NOTE: A positive temperature coefficient or PTC is a thermistor whose resistance increases with increasing temperature.

Problem	Possible Cause	Possible Solutions
1. Low suction.	<ul style="list-style-type: none"> a. Water strainer or solids collector clogged. b. Check valves are stuck. c. Low water pressure. d. Air/Water Separator clogged. e. Solenoids not operating. f. Restricted air exhaust. 	<ul style="list-style-type: none"> a. Clean/replace strainer and/or collector. b. Use a system cleaner like CleanStream; turn vacuum on and off to free check valve. If valve remains stuck, call authorized Air Techniques dealer for repair service. c. Raise water pressure. d. Check and clear Air/Water Separator. Call authorized Air Techniques dealer for repair service. e. Turn vacuum on and off to free solenoid valve. If valve remains stuck call authorized Air Techniques dealer for repair service. f. Check air exhaust pipe size to make sure it conforms to specification; check for and clear possible restrictions in air exhaust system.
2 No suction.	<ul style="list-style-type: none"> a. Pumps off. b. Pumps not running. c. Inlet check valves stuck closed. d. Water inlet filter and/or solids collector clogged. e. Suction hose collapsed. f. Solenoids not operating. g. Water off. 	<ul style="list-style-type: none"> a. Turn pumps on. b. Call authorized Air Techniques dealer for repair service. c. Call authorized Air Techniques dealer for repair service. d. Clean/replace filter. e. Hose needs to be replaced, call authorized Air Techniques dealer for repair service. f. Call authorized Air Techniques dealer for repair service. g. Turn water on via water inlet valve.
3. Excessive suction.	<ul style="list-style-type: none"> a. Vacuum setting set to high 	<ul style="list-style-type: none"> a. Lower vacuum setting or call authorized Air Techniques dealer for repair service.
4 Pumps do not run	<ul style="list-style-type: none"> a. Main circuit breakers off. b. Electrical problem. 	<ul style="list-style-type: none"> a. Turn main circuit breakers on. b. Call authorized Air Techniques dealer for repair service.
5 Noisy pumps.	<ul style="list-style-type: none"> a. Inadequate water supply. b. Drain line collapsed. c. Solenoids not operating. 	<ul style="list-style-type: none"> a. Call plumber to improve water supply system. b. Hose needs to be replaced. Call authorized Air Techniques dealer for repair service. c. Call authorized Air Techniques dealer for repair service.

For over 50 years, Air Techniques has been a leading innovator and manufacturer of dental products. Our priority is ensuring complete satisfaction by manufacturing reliable products and providing excellent customer and technical support. Whether the need is digital imaging, utility room equipment or merchandise, Air Techniques can provide the solution via our network of authorized professional dealers. Proudly designed, tested and manufactured in the U.S., our products are helping dental professionals take their practices to the next level.

Air Techniques' family of quality products for the dental professional include:

- ❑ **Digital Imaging**
 - Digital Radiography
 - Intraoral Camera
 - Caries Detection Aid
 - Intraoral X-ray
 - Panoramic X-ray
 - Film Processors

- ❑ **Utility Room**
 - Dry Vacuums
 - Wet Vacuums
 - Air Compressors
 - Amalgam Separator
 - Utility Accessories
 - Utility Packages

- ❑ **Merchandise**
 - Surface Disinfectant
 - Enzymatic Cleaner
 - Hand Sanitizer and Lotion
 - Waterline Cleaner
 - Evacuation System Cleaner
 - Imaging Accessories
 - Chemistry
 - Processor Accessories

Corporate Headquarters

1295 Walt Whitman Road | Melville, New York 11747- 3062 | Phone: 800-247-8324 | Fax: 888-247-8481

Western Facility

291 Bonnie Lane, Suite 101 | Corona, CA 92880 - 2804 | Phone: 800-247-8324 | Fax: 951-898-7646

www.airtechniques.com



Scan QR Code for more about VacStar NEO

