

Waldorf[®] 800 SERIES

Installation and Operation Manual

Electric Range

Series

RN8610E
RN8610EC

RNL8610E
RNL8610EC



| |
|------------------|
| _____ |
| Date Purchased |
| _____ |
| Serial Number |
| _____ |
| Dealer |
| _____ |
| _____ |
| Service Provider |
| _____ |
| _____ |



For use in GB & IE

230559-9

MANUFACTURED BY

Moffat Limited
PO Box 10001
Christchurch
New Zealand
Ph: (03) 389 1007
Fax: (03) 389 1276

WORLD-WIDE BRANCHES**UNITED KINGDOM**

Blue Seal
67 Gravelly Business Park
Gravelly Park
Birmingham
West Midlands
B24 8TQ
Ph: (121) 327 5575
Fax: (121) 327 9711

UNITED STATES

Moffat Inc
3765 Champion Blvd
Winston-Salem
North Carolina 27115
Ph: (336) 661 0257
Fax: (336) 661 9546

CANADA

Serve Canada
22 Ashwarren Road
Downview
Ontario M3J1Z5
Toll Free:800 263 1455
Ph: (416) 631 0601
Fax: (416) 631 0315
info@servecanada.com
www.servecanada.com
www.moffat.com

NEW ZEALAND**Christchurch**

Moffat Limited
PO Box 10-001
16 Osborne Street
Christchurch
Ph: (03) 389 1007
Fax: (03) 389 1276

Auckland

Moffat Limited
4 Waipuna Road
Mt Wellington
Auckland
Ph: (09) 574 3150
Fax: (09) 574 3159

AUSTRALIA**Victoria**

Moffat Pty Limited
740 Springvale Road
Mulgrave, Melbourne
Victoria 3171
Ph: (03) 9518 3888
Fax: (03) 9518 3838

New South Wales

Moffat Pty Limited
3/142 James Ruse Drive, Rose Hill
PO Box 913, Smithfield
Sydney, N.S.W. 2142
Ph: (02) 8833 4111
Fax: (02) 8833 4133

Western Australia

Moffat Pty Limited
67 Howe Street
Osbourne Park
WA 6017
Ph: (08) 9202 6820
Fax: (08) 9202 6836

Queensland

Moffat Pty Limited
30 Prosperity Place
Geebung, Brisbane
Queensland 4034
Ph: (07) 3630 8600
Fax: (07) 3630 8623

The reproduction or copying of any part of this manual by any means whatsoever is strictly forbidden unless authorized previously in writing by the manufacturer.

In line with policy to continually develop and improve its products, Moffat Ltd. reserves the right to change the specifications and design without prior notice.

Waldorf Electric Ranges Convection / Static Ovens - 900 mm

| | |
|--------------------|--|
| RN(L)610E | Electric Range Static Oven. |
| RN(L)8613E | Electric Range Static Oven. |
| RN(L)8616E | Electric Range Static Oven. |
| RN(L)8619E | Electric Range Static Oven. |
| RN(L)8610EC | Electric Range Convection Oven. |
| RN(L)8613EC | Electric Range Convection Oven. |
| RN(L)8616EC | Electric Range Convection Oven. |
| RN(L)8619EC | Electric Range Convection Oven. |

| | |
|---|-----------|
| Introduction | 2 |
| Specifications | 3 |
| Model Numbers Covered in this Specification | |
| General | |
| Electrical Supply Requirements | |
| Electrical Connection | |
| Dimensions | |
| Installation | 5 |
| Installation Requirements | |
| Unpacking | |
| Location | |
| Clearances | |
| Assembly | |
| Fitting Rear Rollers | |
| Electrical Connection | |
| Commissioning | |
| Operation | 9 |
| Operation Guide | |
| Description of Controls | |
| Radiant Elements | |
| Griddle Plate | |
| Oven | |
| Cleaning and Maintenance | 12 |
| General | |
| After Each Use | |
| Daily Cleaning | |
| Weekly Cleaning | |
| Periodic Maintenance | |
| Fault Finding | 15 |
| Circuit Schematics | 16 |
| Replacement Parts | 21 |

Introduction

We are confident that you will be delighted with your WALDORF ELECTRIC RANGE and it will become a most valued appliance in your commercial kitchen.

To ensure you receive the utmost benefit from your new Waldorf ELECTRIC RANGE, there are two important things you can do.

Firstly:

Please read the instruction book carefully and follow the directions given. The time taken will be well spent.

Secondly:

If you are unsure of any aspect of the installation, instructions or performance of your appliance, contact your WALDORF dealer promptly. In many cases a phone call could answer your question.

CE Only:

These instructions are only valid if the country code appears on the appliance. If the code does not appear on the appliance, refer to the supplier of this appliance to obtain the technical instructions for adapting the appliance to the conditions for use in that country.

WARNING:

IMPROPER INSTALLATION, ADJUSTMENT, ALTERATION, SERVICE OR MAINTENANCE CAN CAUSE PROPERTY DAMAGE, INJURY OR DEATH. READ THE INSTALLATION, OPERATING AND MAINTENANCE INSTRUCTIONS THOROUGHLY BEFORE INSTALLING OR SERVICING THIS APPLIANCE.

WARNING:

GREAT CARE MUST BE TAKEN BY THE OPERATOR TO USE THE EQUIPMENT SAFELY TO GUARD IT AGAINST RISK OF FIRE.

- **THE APPLIANCE MUST NOT BE LEFT ON UNATTENDED.**
- **IT IS RECOMMENDED THAT A REGULAR INSPECTION IS MADE BY A COMPETENT SERVICEMAN TO ENSURE CORRECT AND SAFE OPERATION OF YOUR APPLIANCE IS MAINTAINED.**
- **DO NOT STORE OR USE GASOLINE OR OTHER FLAMMABLE VAPOURS OR LIQUIDS IN THE VICINITY OF THIS OR ANY OTHER APPLIANCE.**
- **DO NOT SPRAY AEROSOLS IN THE VICINITY OF THIS APPLIANCE WHILE IT IS IN OPERATION.**

CAUTION:

This appliance is;

- **For professional use and is to be used by qualified persons only.**
- **Only authorised service persons are to carry out installation, servicing and gas conversion operations.**
- **Components having adjustments protected (e.g. paint sealed) by the manufacturer should not be adjusted by the user / operator.**
- **DO NOT operate the appliance without the legs supplied fitted.**

Model Numbers Covered in this Specification

| | |
|--------------------|--|
| RN[1]8610E | Electric Range Static Oven + 6 Radiant Elements. |
| RN[1]8613E | Electric Range Static Oven + 4 Radiant Elements + 300 mm Griddle. |
| RN[1]8616E | Electric Range Static Oven + 2 Radiant Elements + 600 mm Griddle. |
| RN[1]8619E | Electric Range Static Oven + 900 mm Griddle. |
| | |
| RN[1]8610EC | Electric Range Convection Oven + 6 Radiant Elements. |
| RN[1]8613EC | Electric Range Convection Oven + 4 Radiant Elements + 300 mm Griddle. |
| RN[1]8616EC | Electric Range Convection Oven + 2 Radiant Elements + 600 mm Griddle. |
| RN[1]8619EC | Electric Range Convection Oven + 900 mm Griddle. |

[1]: - Back Options;

- - Standard Models.
- L - Low Back Models.

General

A commercial heavy duty, 900 mm wide Electric Range designed for modular kitchens and is constructed in an easy clean stainless steel external finish.
 The range is fitted with either a 900 mm 6.5kW electric static oven or convection oven.
 The hob is divided into modular sections of griddle plates and radiant elements (solid or open).

Electrical Supply Requirements

| Model | Power Supply | | | Total Power Input | Amps @ 400 - 415 Vac | | | Motor |
|-----------------|--------------|---------|------------|-------------------|----------------------|------|------|-------|
| | Voltage | Type | Frequency | | L1 | L2 | L3 | |
| RN8610E | 400-415 Vac | 3 P+N+E | 50 / 60 Hz | 20.9 kW | 28.3 | 29.4 | 29.4 | ---- |
| RN8613E | 400-415 Vac | 3 P+N+E | 50 / 60 Hz | 19.7 kW | 22.5 | 29.4 | 29.4 | ---- |
| RN8616E | 400-415 Vac | 3 P+N+E | 50 / 60 Hz | 18.5 kW | 22.5 | 23.6 | 29.4 | ---- |
| RN8619E | 400-415 Vac | 3 P+N+E | 50 / 60 Hz | 17.3 kW | 22.5 | 23.6 | 23.6 | ---- |
| RN8610EC | 400-415 Vac | 3 P+N+E | 50 Hz | 21.2 kW | 28.7 | 29.4 | 29.4 | 100W |
| RN8613EC | 400-415 Vac | 3 P+N+E | 50 Hz | 20.0 kW | 22.9 | 29.4 | 29.4 | 100W |
| RN8616EC | 400-415 Vac | 3 P+N+E | 50 Hz | 18.8 kW | 22.9 | 23.6 | 29.4 | 100W |
| RN8619EC | 400-415 Vac | 3 P+N+E | 50 Hz | 17.6 kW | 22.9 | 23.6 | 23.6 | 100W |

Electrical Connection

WARNING:

THIS APPLIANCE MUST BE EARTHED. IF THE SUPPLY CORD IS DAMAGED, IT MUST BE REPLACED BY A SUITABLY QUALIFIED PERSON IN ORDER TO AVOID A HAZARD.

Electrical supply connection point is located at the rear of the appliance, approximately 80 mm from the right hand side, 466 mm from the rear and 150 mm from the floor.

When connecting a this electric appliance to the mains supply, ensure that the following is carried out:-

- An isolating switch is fitted within 2m of the appliance, but not on the appliance and in such a position that the user does not have to reach across the cooking surface.
- Supply cord shall be oil-resistant, sheathed flexible cable and not lighter than ordinary polychloroprene or other equivalent synthetic elastomer sheathed cord (as per AS / NZS 3191 part 2.10.11. or IEC 60245-IEC-57) e.g. HO5 RN-F Type.
- The branch supply line shall be individually overload protected to the correct current rating and the supply chord shall be protected against any mechanical or thermal damage.
- A grommet is fitted around the wiring entry hole into the appliance.
- Supply cable wires should be boot laced and all terminal connections must be tight to avoid potential self-overheating.

Refer to the appropriate wiring standards for the size of cable that is to be supplied to an appliance for the current drawn on that line.

Dimensions

RN(L)8610E / EC

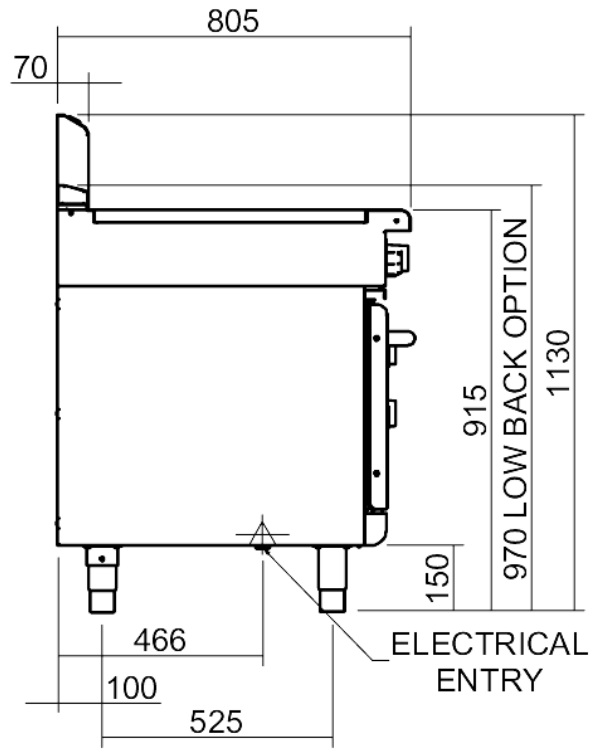
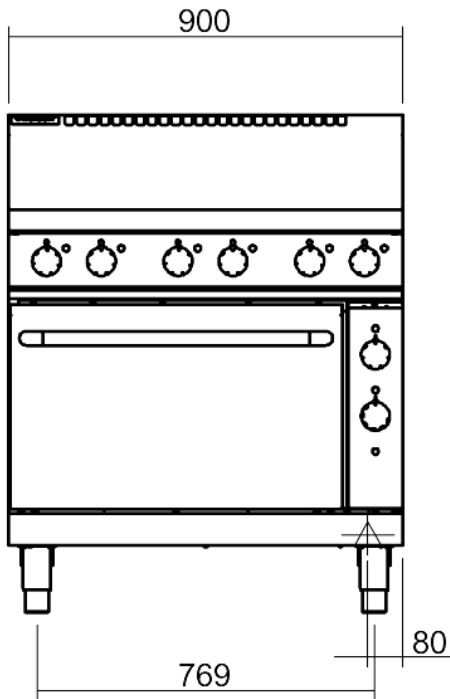

Hob Options

RN(L)8610E /

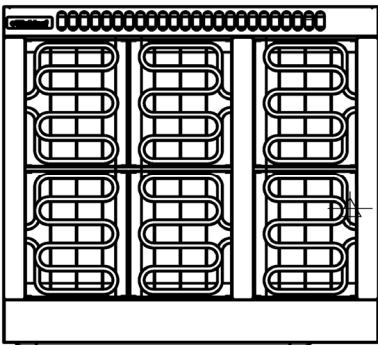

RN(L)8613E /

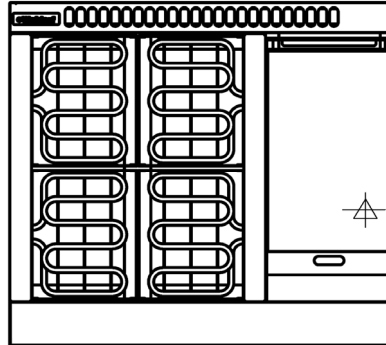

RN(L)8616E /

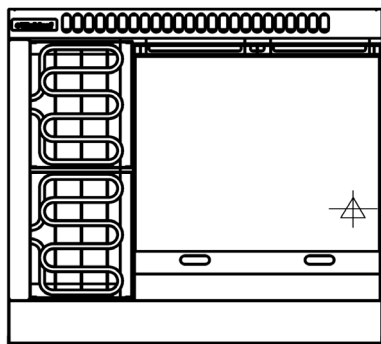

RN(L)8619E /

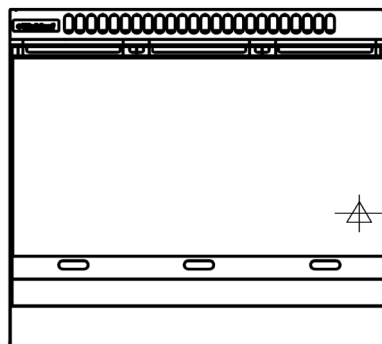

Installation Requirements

NOTE:

- It is most important that this Electric Range Static / Convection Oven is installed correctly and that operation is correct before use. Installation shall comply with local electrical and health and safety requirements.
- This appliance shall be installed with sufficient ventilation to prevent the occurrence of unacceptable concentrations of health harmful substances in the room, the appliance is installed in.

Waldorf Electric Range Static / Convection Oven are designed to provide years of satisfactory service, and correct installation is essential to achieve the best performance, efficiency and trouble-free operation. This appliance must be installed in accordance with National Installation Codes and in addition, in accordance with relevant National / Local codes covering electrical and fire safety.

Australia / New Zealand: - AS / NZS3000 - Wiring Rules.
United Kingdom: - BS 7671 - Requirements for Electrical Installations.

Installations must be carried out by authorised persons only. Failure to install equipment to the relevant codes and manufacturer's specifications shown in this section will void the warranty.

Unpacking

1. Remove all packaging and transit protection from the appliance including all protective plastic coating from the exterior stainless steel panels.
2. Check equipment and parts for damage. Report any damage immediately to the carrier and distributor.
3. Report any deficiencies to the distributor who supplied the appliance.
4. Check that the available electrical supply is correct to that shown on the lower right hand front sill panel.

Location

1. Installation must include adequate clearance and ventilation.
2. Position the appliance in its approximate working position.
3. The legs must always be fitted. Ensure that the legs are securely attached.

Clearances

| | Combustible Surface | Non Combustible Surface |
|------------------------|---------------------|-------------------------|
| Left / Right hand side | 250mm | 0mm |
| Rear | 50mm | 0mm |

NOTE: Only non-combustible materials can be used in close proximity to this appliance.

Installation

Assembly

CAUTION:

- **This appliance is for professional use and is to be used by qualified persons only.**
- **Only qualified service persons are to carry out installation and servicing of this appliance.**

All Models

This model is delivered completely assembled. Ensure that the legs are securely attached.

NOTE:

- **This appliance is fitted with adjustable feet to enable it to be positioned securely and level on uneven floors. This should be carried out on completion of the gas connection. Refer to the 'Gas Connection Section'.**
- **This appliance can also be fitted with rear rollers to enable the appliance to be easily moved for positioning and cleaning purposes. If desired, these rollers are supplied in the packaging, with the appliance. See below for fitting instructions.**

Optional Accessories (Refer to Replacement Parts List)

- **Plinth Kit.** For installation details, refer to the instructions supplied with each kit.

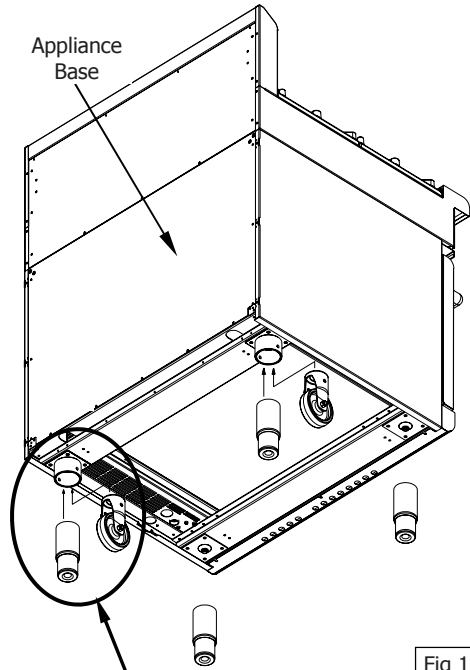
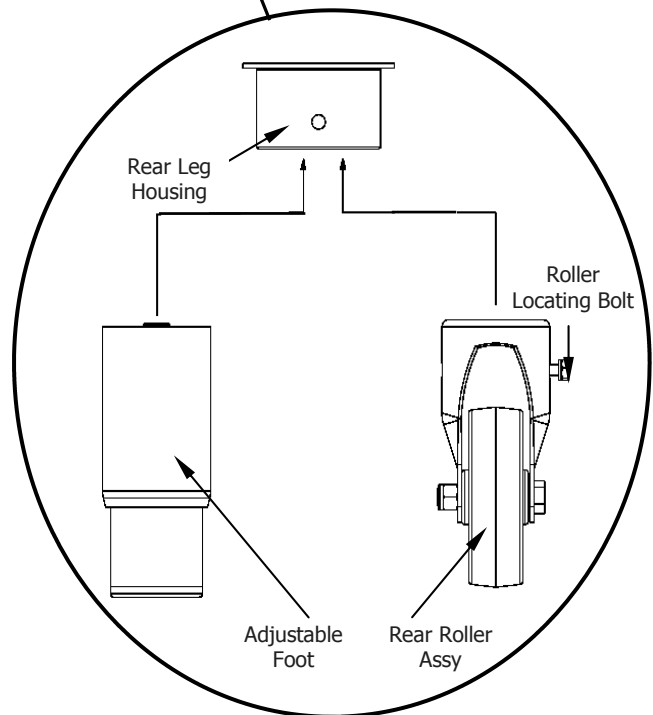

Fig 1

Fitting Rear Rollers.

1. Raise the appliance from the floor by approx. 75mm using suitable lifting equipment (i.e. Palletiser / Forklift) to allow the rear adjustable feet to be removed.
2. Unscrew and remove both the rear adjustable feet from the rear leg housings.
3. Fit the rear roller to the rear leg housing and align the screw hole in the side of the rear leg housing with the threaded hole in the rear roller.
4. Secure the rear roller to the leg support with the bolt supplied and tighten the bolt using a 10mm A/F spanner.
5. Fit the second roller and tighten.
6. Lower the appliance back to the floor and adjust the front adjustable feet to level the appliance.



Electrical Connection

WARNING:

THIS APPLIANCE MUST BE EARTHED. IF THE SUPPLY CORD IS DAMAGED, IT MUST BE REPLACED BY A SUITABLY QUALIFIED PERSON IN ORDER TO AVOID A HAZARD.

NOTE: ALL ELECTRICAL CONNECTIONS MUST ONLY BE CARRIED OUT BY AN AUTHORISED PERSON.

Each appliance should be connected to an adequately protected power supply and isolation switch mounted adjacent to, but not behind the appliance. This switch must be clearly marked and readily accessible in case of fire.

1. Check that the electricity supply is correct as shown on the Rating Plate attached to the lower front hand side of the front sill panel.
2. The supply terminal connections are located at the rear of the the appliance. Refer to 'Electrical Connections' in the 'Specifications' section of the manual.
3. Open the door and remove the control panel to allow connection access for the electrical supply.
4. Bring the supply cable up through the compression type gland provided on the rear of the main electrical switchgear panel.
5. Connect the mains supply to L1, L2 and L3 connections for 3 phases. Refer to the 'Electrical Supply Requirements' section for connection details.
6. Connect neutral and earth conductors to neutral stud and earth stud respectively.
7. For all connections ensure that conductors are secure and appropriately terminated.
8. Tighten the cable gland to secure against tension on the cable.



NOTE:

- **This appliance must be earthed.**
 - **Fixed wiring installations must incorporate an all-pole disconnection switch.**
9. Correctly locate the appliance into its final operating position and using a spirit level, adjust the legs so that the appliance is level and at the correct height.
 10. Connect the power supply to the appliance.
 11. Check that the electrical supply is as shown in the 'Specifications' section.

Installation

Commissioning

1. Before leaving the new installation;
 - a. Check the following functions in accordance with the operating instructions specified in the 'Operation' section of this manual.
 - Check the current draw and loading for the equipment. Refer to the 'Specifications' section for correct electrical requirements.
 - Check that all the connections are correct and that all cover panels have been re-fitted.
 - Check that the appliance functions in accordance with the operating instructions.
 - Ensure that this instruction manual is left with the appliance.
 - Ensure that all the relevant details and contacts have been added to the front of this manual.
 - b. Ensure that the operator has been instructed in the areas of correct operation and shutdown procedure for the appliance.
2. This manual must be kept by the owner for future reference and as a record of ***Date of Purchase, Date of Installation*** and ***Serial Number of Unit*** are to be recorded and kept with this manual. **(These details can be found on the Rating Plate.** (Refer to the 'Electrical Connection' section for rating plate location).

NOTE:

- **If for some reason it is not possible to get the appliance to operate correctly, turn off the electrical power supply and contact a qualified service person. The supplier of this appliance will be able to recommend a suitable person.**
- **Make sure that the electrical supply is turned off before any service or maintenance work is carried out.**

Operation Guide

CAUTION:

- **This appliance is for professional use and is to be used by qualified persons only.**
- **Only qualified service persons are to carry out installation and servicing of this appliance.**

1. Waldorf Electric Range Static / Convection Ovens have been designed to provide simplicity of operation. They can be fitted with 300 mm, 600 mm or 900 mm griddle option depending on range size.
2. Improper operation is therefore almost impossible, however bad operation practices can reduce the life of the appliance and produce a poor quality product. To use this appliance correctly please read the following sections carefully:-

- **Radiant Elements (Solid or Open).**
- **Griddle Plate.**
- **Oven.**

Description of Controls



Griddle Plate Control Knob (If Fitted)

- OFF Position
- 50°C to 300°C Temperature Graduations

Power Indicator Lamps (green)

Heating Indicator Lamps (Amber) Griddle Only

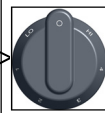

Hotplate Heat Control Oven Top Heat Control

- OFF Position
- LOW** Position
- 1** Position
- 2** Position
- 3** Position
- 4** Position
- HIGH** Position

Heating Indicator Lamps (Amber) for Top & Bottom Elements

Power Indicator Lamp (green)



Oven Thermostat Control Knob

- OFF Position
- 50°C to 300°C Temperature Graduations

Fig 3

Operation

Hob Element / Griddle Options

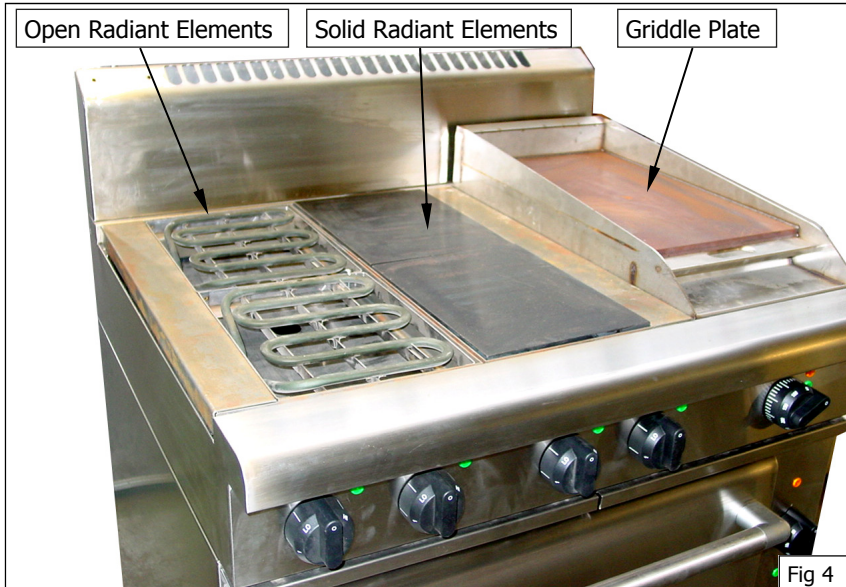

Radiant Elements (Solid or Open)

The controls for the radiant elements may be set at any position between high and low to provide the desired level of heating. An individual green neon for each element, will glow when the element is switched 'ON' to show that there is power to the element.

Start cooking at the highest setting and change to a lower setting when the desired temperature is reached.

For maximum speed and economy, it is most important that cooking utensils should cover the element completely, and have perfectly flat bases. Any part of the element which glows bright red is not making effective contact with the base of the utensil, and this decreases the life and efficiency of the element.

Utensils which are significantly larger than the element may also reduce element life and efficiency.

Griddle Plate

Turn the thermostat control to the desired temperature. An individual amber neon for each griddle element, will glow when the element cycles on and extinguish when the element cycles off. When the amber neon goes out, the desired temperature has been reached and the griddle is ready for use.

Turning the control to a higher setting than required **will not** shorten the heat up time.

Oven

! IMPORTANT DO NOT USE aluminium foil or trays directly on the cast iron sole plate(s). NEVER block or cover the openings on each side of the sole plate(s).

The oven is fitted with top and bottom elements. The thermostat maintains the overall oven temperature. The top element is further controlled by the oven top heat control. Convection Ovens (RN8610EC) are fitted with a circulation fan.

NOTE: The Thermostat on the oven provides overall control of the temperature within the oven by controlling both elements, where as the Oven Top Heat Control provides a means of balancing the distribution of heat between the top and bottom of the oven.

Place oven racks in desired position.

! IMPORTANT DO NOT USE aluminium foil or trays directly on the cast iron sole plate(s). NEVER block or cover the openings on each side of the sole plate(s).

Preheat:

Preheat the oven by selecting the desired temperature, and turning the oven top heat control (Refer to Fig 3 on the previous page) to a maximum of 2. When the desired temperature is reached, the amber neon will go out.

Cooking:

When the desired temperature has been reached, load the oven with product and set the oven top heat control to the desired setting.

NOTE: When the oven top heat control is set to a high setting, proportionally more heat is produced at the top of the oven. (This can be used for browning, etc, during the cooking operation). With the oven top heat control set on a low setting, less heat is produced from the top oven elements. (This mode is used for general baking purposes to prevent cakes, etc, from getting too brown and crisp on the top, but allow the cake to cook through).

To obtain more top heat during cooking, turn the oven top heat control to a higher position. (The higher the setting, the more top heat).

Turning 'OFF' the Oven:

- a. Turn the oven top heat control to the 'O' off position. The top heating will be turned 'OFF' and the upper heating indicator lamp (Amber) will extinguish.
- b. Turn the thermostat control knob to the 'O' off position and the lower heating indicator lamp (Amber) will extinguish. The oven is now turned 'OFF'.

Cleaning and Maintenance

CAUTION:

Always turn off the electrical power supply at the mains supply before cleaning.
This appliance is not water proof.
Do not use water jet spray to clean interior or exterior of this appliance.

General

Clean the range regularly. A clean appliance looks better, will last longer and will perform better. Carbonised grease on the surface or on the griddle plate (If fitted) will hinder the transfer of heat from the cooking surface to the food. This will result in loss of cooking efficiency.

NOTE: Each griddle option can be supplied with a scraper tool and a pack of blades for cleaning the griddle surface. These are not supplied with the griddle and have to be purchased separately. Refer to the 'Replacement Parts List' at the rear of this manual.

WARNING:

THE BLADES FITTED TO THE SCRAPER TOOL ARE EXTREMELY SHARP AND ARE TO BE USED WITH CARE.

DO NOT use water on the griddle plate while this item is still hot as warping and cracking may occur. Allow the griddle plate to cool down before cleaning.

NOTE:

- DO NOT use abrasive detergents, strong solvents or caustic detergents as they could corrode or damage the range.
- In order to prevent the forming of rust on the griddle plate (Steel Plate), ensure that any detergent or cleaning material has been completely removed after each cleaning. The appliance should be switched on briefly to ensure the griddle plate becomes dry. Oil or grease should be spread over the griddle surface in order to form a thin protective greasy film.

To keep your range clean and operating at peak efficiency, follow the procedures shown below:-

After Each Use

1. Clean the griddle with a scraper tool to remove any food debris.

CAUTION:

Always ensure that an even pressure is applied over the whole surface of the scraper tool when using on the flat surface of the griddle, to prevent scoring of the surface.

NEVER bang the sharp edge of the scraper tool on the flat surface of the griddle as this will damage the finish and invalidate the warranty.

2. Always ensure that the scraper tool blades are changed regularly to ensure that the scraper tool works efficiently and prevents damage to the griddle plate surface.

Radiant Elements

- a. Wipe the surface while the radiant elements are still warm to remove overspills, grease etc. before they harden.
- b. As soon as elements have cooled, wipe all over with a damp cloth.
- c. Raise the side of the element module and withdraw, clean and dry the spill-over dish.

Daily Cleaning

1. The grease drawer should be checked and emptied frequently to prevent overflow and spillage. Remove the grease drawer while still warm so that the grease is in a liquid state. Empty any grease from the drawer and wash thoroughly in the same manner as any cooking utensil.
2. Thoroughly clean the splash back, the interior and exterior surfaces of the range with hot water, a detergent solution and a soft scrubbing brush.
3. Clean the Control Panel with a damp cloth lightly moistened with a solution of mild detergent and water. Dry the control panel thoroughly with a dry cloth and polish with a soft dry cloth.
4. Brush the griddle surface (optional - if fitted) with a soft bristled brush. Any carbon deposits should be removed using the supplied scraper tool followed by wiping with a cloth to prevent accumulation of food deposits.
5. Brush the elements with a soft bristled brush. Any carbon deposits should be removed using a scraper tool followed by wiping with a cloth moistened in a solution of hot water and detergent to prevent accumulation of food deposits.
6. To clean under the elements, carry out the following procedure as shown opposite:-

- A.** Lift up the element module at the front of the cooktop.
- B.** Whilst holding up the front of the element module, pull the module as far forward as it will come.
- C.** Rotate the element module around the element pivot plate on whichever side of the cooktop that the pivot plate is located.
- D.** Remove the drip tray from beneath the element and wash with hot water and a detergent solution. Dry with a soft dry cloth.
Clean beneath the element using a cloth moistened in a solution of hot water and detergent.
Refit the drip tray beneath the element ensuring that the drip tray is fitted correctly. Lower the element module back down to the cooktop frame and slide rearwards to fit back into position on the cooktop surface.

7. Dry the range thoroughly with a dry cloth and polish with a soft dry cloth.

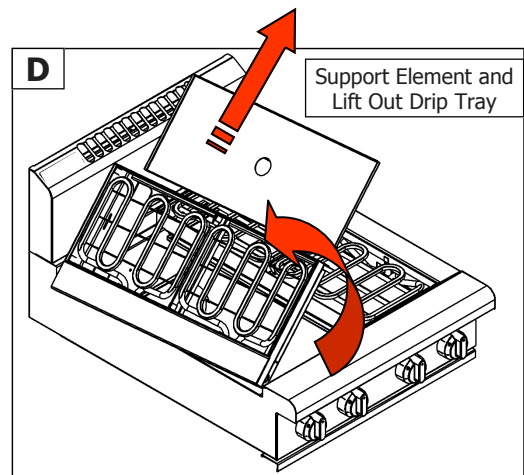
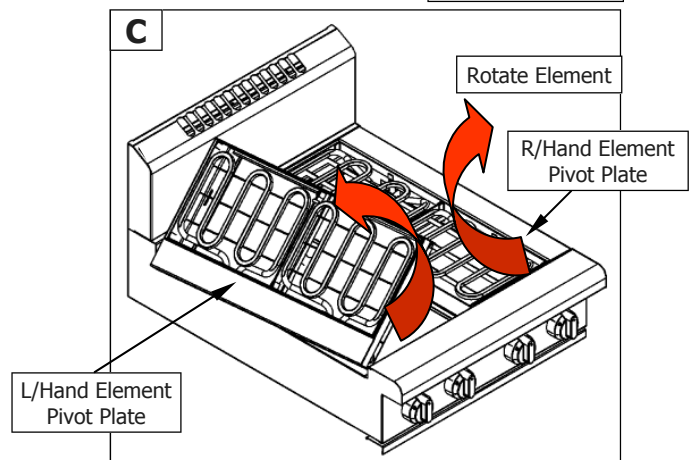
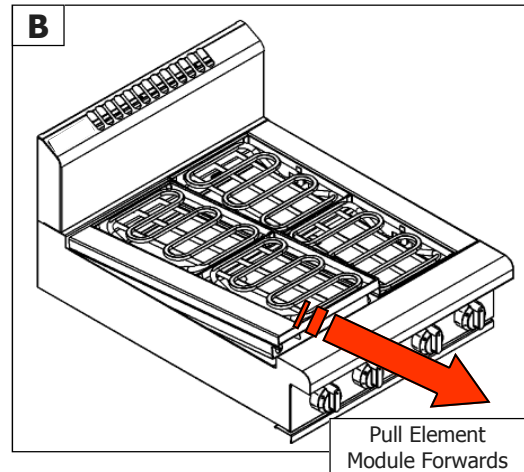
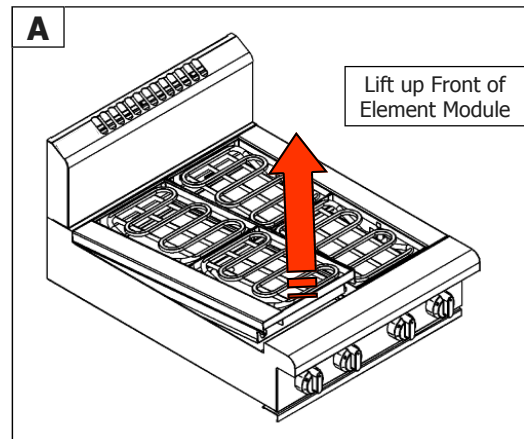

Cleaning and Maintenance

Weekly Cleaning

NOTE:

- If the range usage is very high, we recommend that the weekly cleaning procedure is carried out on a more frequent basis.
- Ensure that protective gloves are worn during the cleaning process.
- DO NOT use harsh abrasive detergents, strong solvents or caustic detergents as they will damage the Cooktop and elements.
- DO NOT use water on the griddle plate (optional - if fitted) while it is still hot as warping may occur. Allow these items castings to cool and remove for cleaning.

Griddle - Steel Plate (Optional - if fitted)

NOTE: In order to prevent the forming of rust on the griddle plate, ensure that all detergent and cleaning material has been entirely removed after each cleaning process. The appliance should be switched on briefly to ensure the griddle plate becomes dry. Oil or grease should be spread over the griddle surface in order to form a thin protective greasy film.

- a. Remove and clean the grease collection drawer frequently to prevent over spills.
- b. Clean the griddle surface thoroughly with a scraper tool or a wire brush. If necessary use a griddle stone or a scotch bright pad on the griddle surface for the removal of stubborn or accumulated carbon deposits..
- c. Occasionally bleach the griddle plate with vinegar when the plate is cold.
- d. Clean with hot water, a mild detergent solution and a scrubbing brush. Dry all components thoroughly with a dry cloth.
- e. The griddle should be switched on briefly to ensure that the griddle plate becomes dry. A thin smear of cooking oil should be spread over the griddle in order to form a protective film.

Radiant Elements and Cooking Area

- a. Clean the radiant elements and cooking area with a soft cloth and a mild detergent and hot water solution.
- b. Baked on deposits or discolouration may require a good quality stainless steel cleaner or stainless steel wool. Always apply cleaner when the appliance is cold.
- c. Remove the grease drawer and clean with a mild anti bacterial detergent and hot water solution using a soft bristled brush. Dry the grease drawer thoroughly with a dry cloth.
- d. Clean beneath the elements and the element frame drip trays as shown in 'Daily Cleaning' on the previous page.

Stainless Steel Surfaces

- a. Clean the exterior surfaces of the Cooktop with hot water, a mild detergent solution and a soft scrubbing brush. Note that the control knobs are a push fit onto the control spindles and can be removed to allow cleaning of the front control panel.
- b. Baked on deposits or discolouration may require a good quality stainless steel cleaner or stainless steel wool. Always apply cleaner when the appliance is cold and rub in the direction of the grain.
- c. To remove any discolouration, use an approved stainless steel cleaner or stainless steel wool. Always rub in the direction of the grain.
- d. Remove the grease tray and clean with a mild anti bacterial detergent and hot water solution using a soft bristled brush.
- e. Dry the grease tray thoroughly with a dry cloth.
- f. Dry all components thoroughly with a dry cloth and polish with a soft dry cloth.

Periodic Maintenance

To achieve the best results cleaning must be regular and thorough and all controls and mechanical parts checked and adjusted periodically by a competent serviceman. If any small faults occur, have them attended to promptly. Don't wait until they cause a complete breakdown. It is recommended that the appliance is serviced every 6 months.

Fault Finding

This section provides an easy reference guide to the more common problems that may occur during the operation of your appliance. The fault finding guide in this section is intended to help you correct, or at least accurately diagnose problems with your equipment.

Although this section covers the most common problems reported, you may encounter a problem not covered in this section. In such instances, please contact your local authorised service agent who will make every effort to help you identify and resolve the problem. Please note that the service agent will require the following information:-

- **The Model Trade Name and the Serial Number of the Appliance. (both can be found on the Technical Data Plate located on the appliance.**

| Fault | Possible Cause | Remedy |
|---|--|--|
| Element does not work when turned 'ON'. | Check individual fuses located behind the control panel. Check for an electrical short by checking that there is NO continuity between any "phase in" line and the metal appliance body itself. Check for the item failing (element, control etc) by using a multimeter as shown on following pages. | Replace the blown fuse. Call the service provider. |
| Complete power failure of the appliance | Check fuse connection at the mains supply. Ensure that the fuse size is correct to carry the load. Check for an electrical short to the appliance. | Replace the blown fuse. Carry out a continuity and resistance check on the appliance. Call the service provider. |

Circuit Schematics

Static Ovens (RN8610E Series)

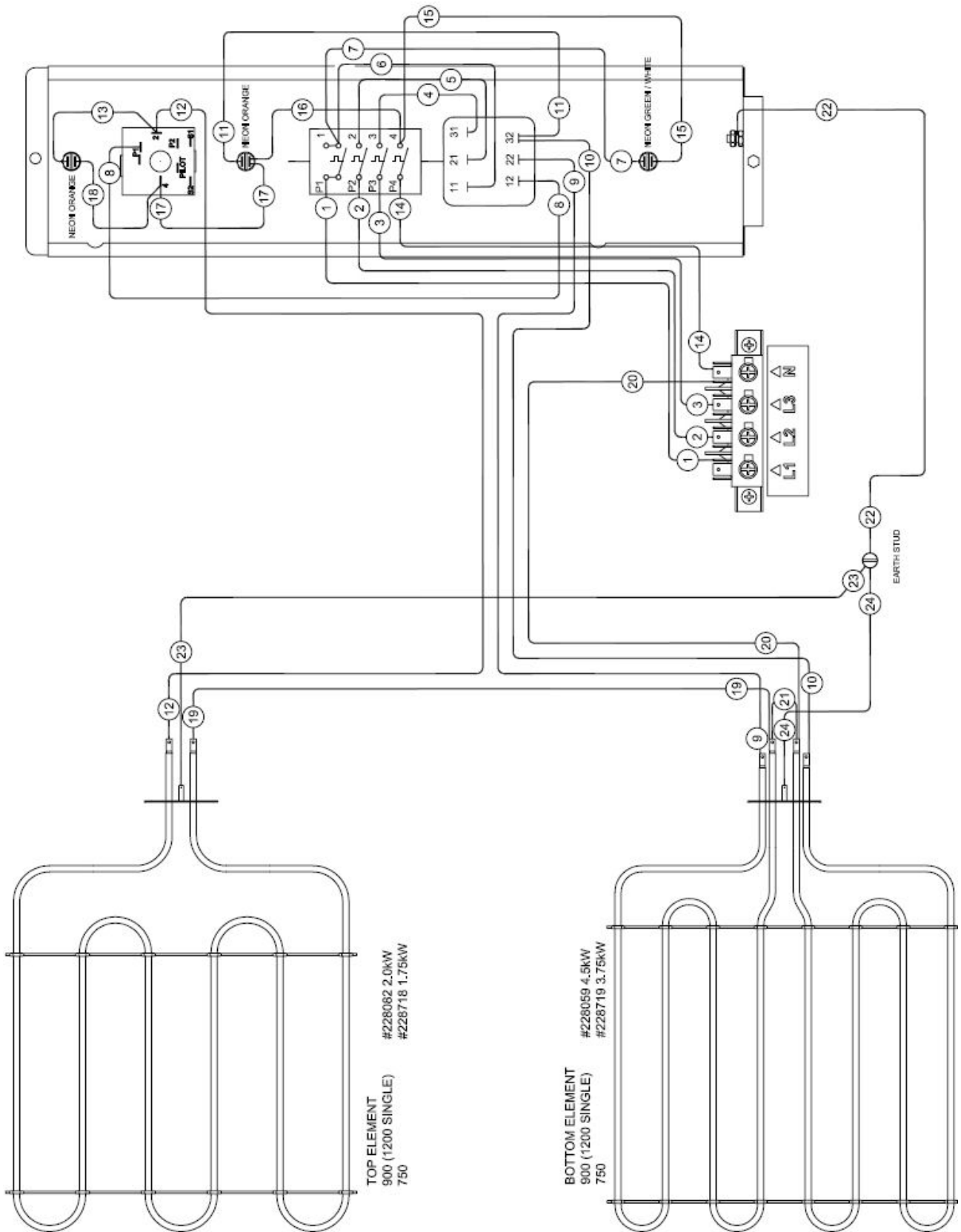

Convection Ovens (RN8610EC Series)

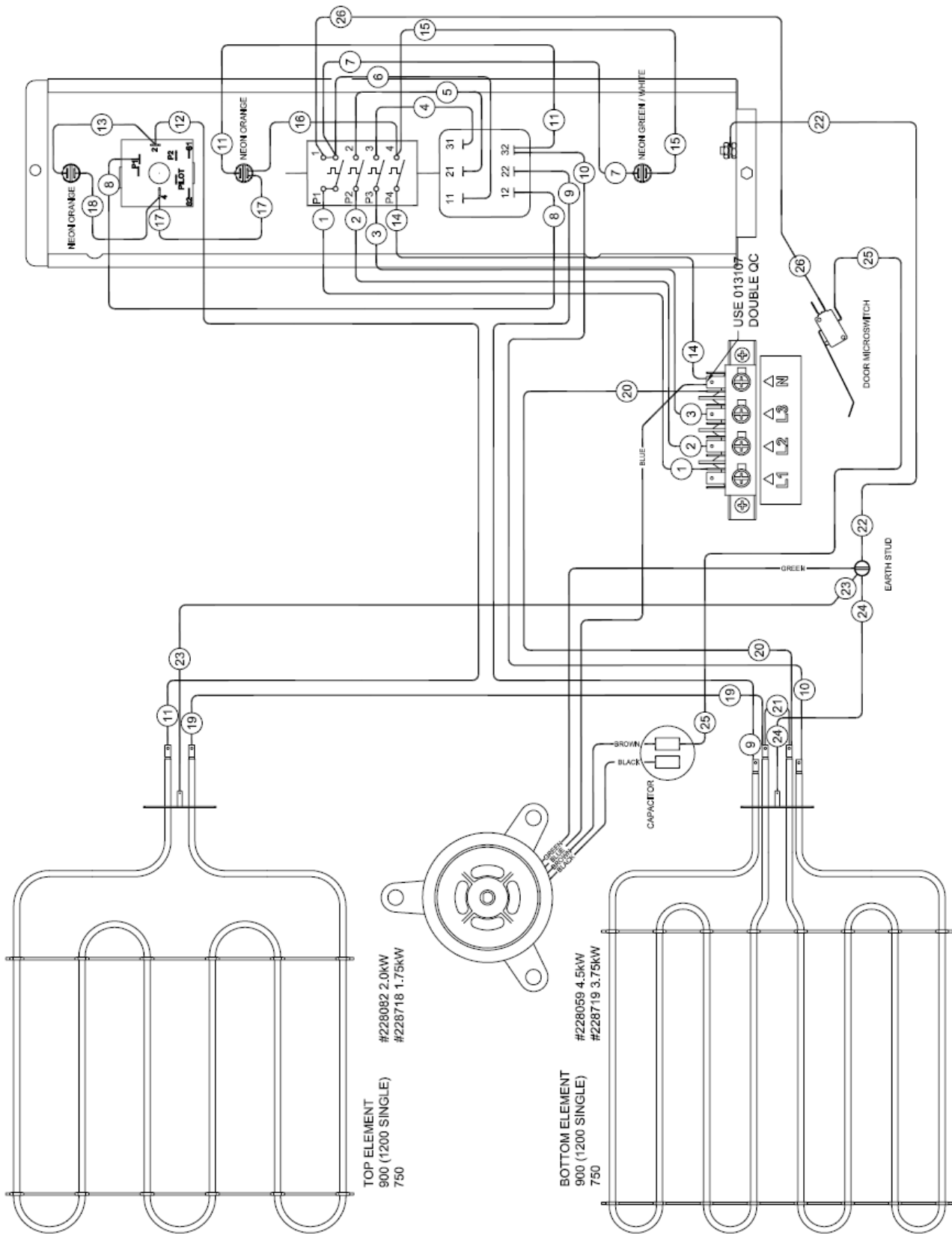

Circuit Schematics

Cooktop - 6 Elements (RN8610E/EC Models)

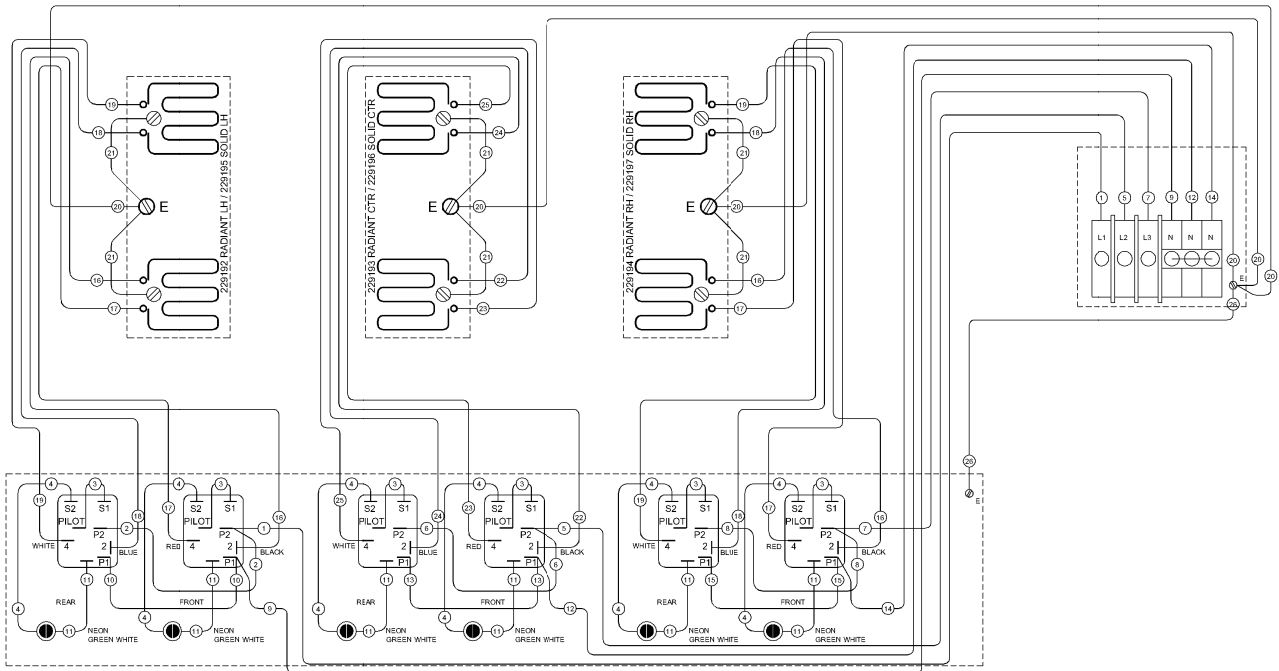

Cooktop - 4 Elements - 300 mm Griddle (RN8613E/EC Models)

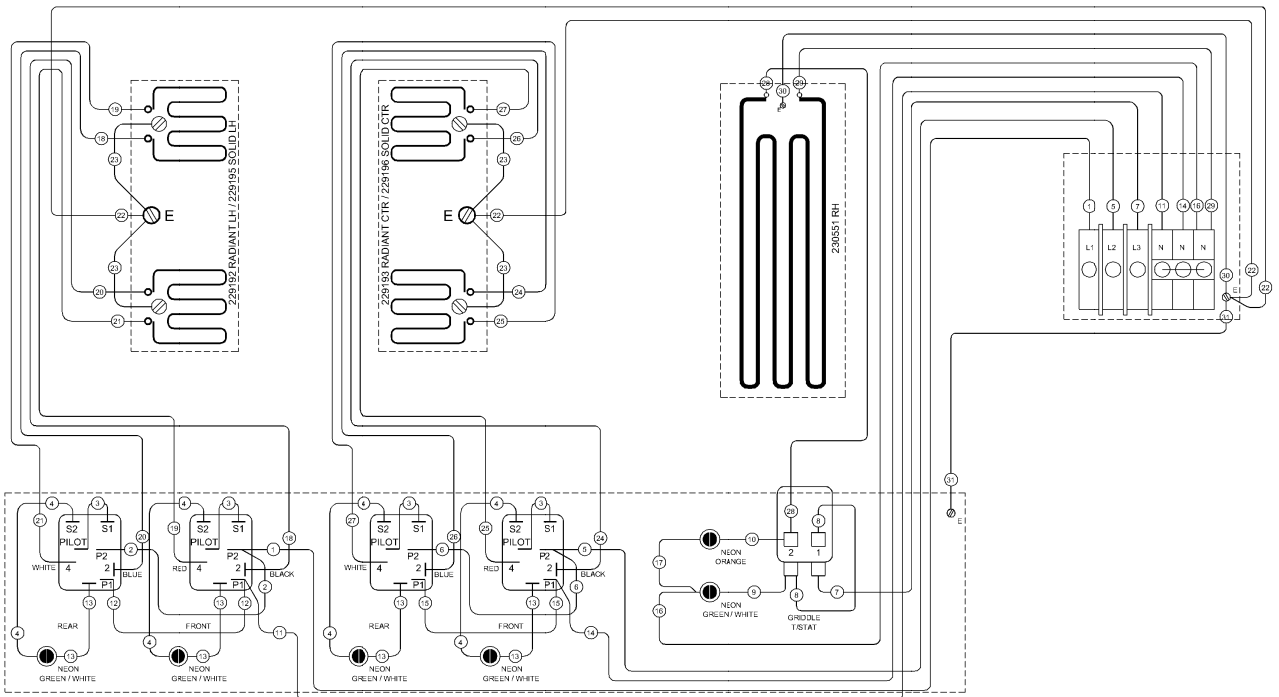

Cooktop - 2 Elements - 600 mm Griddle (RN8616E/EC Models)

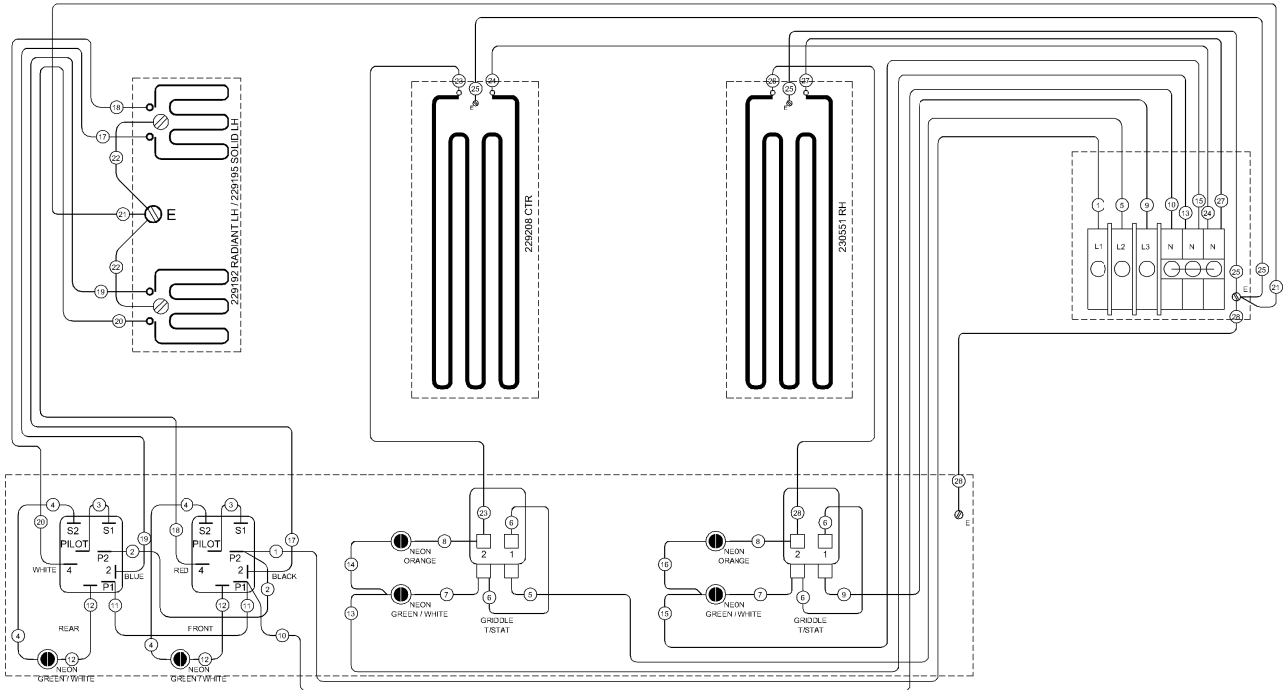

Cooktop - 900 mm Griddle (RN8619E/EC Models)

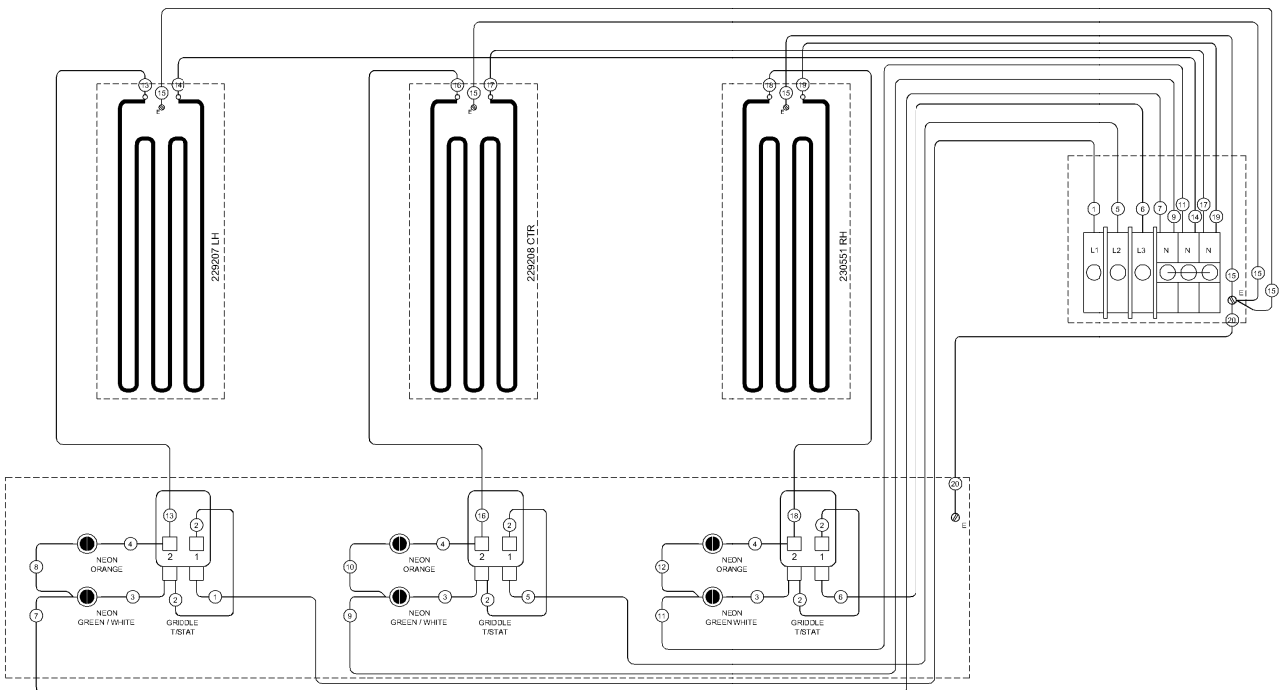

Circuit Schematics

Wiring Layout for Static Oven

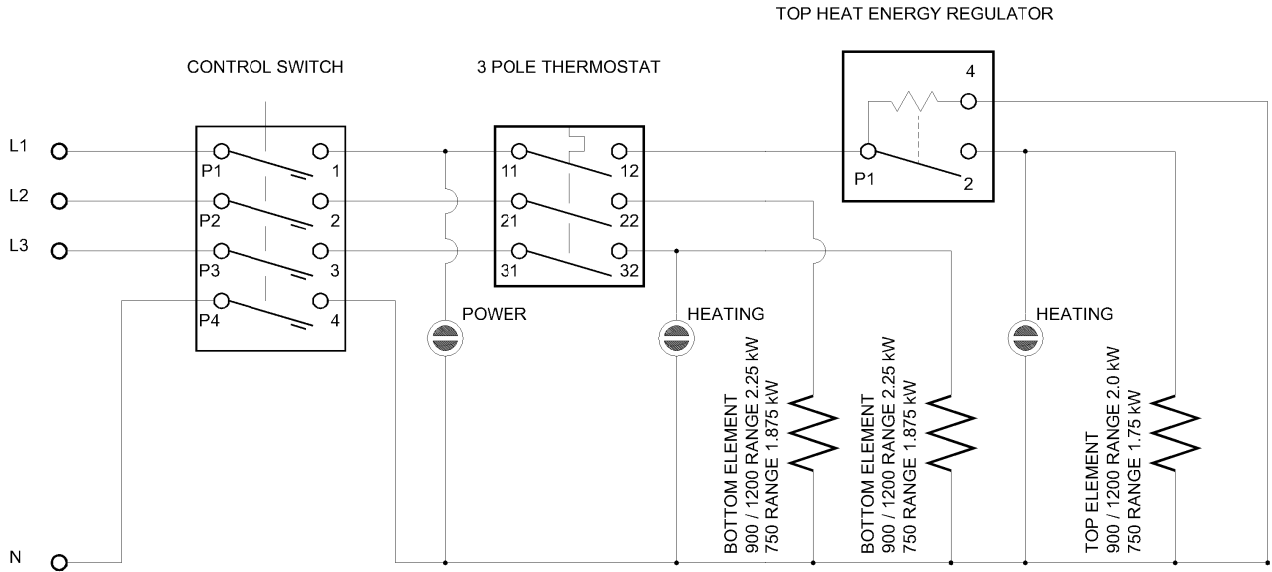

Wiring Layout for Convection Oven

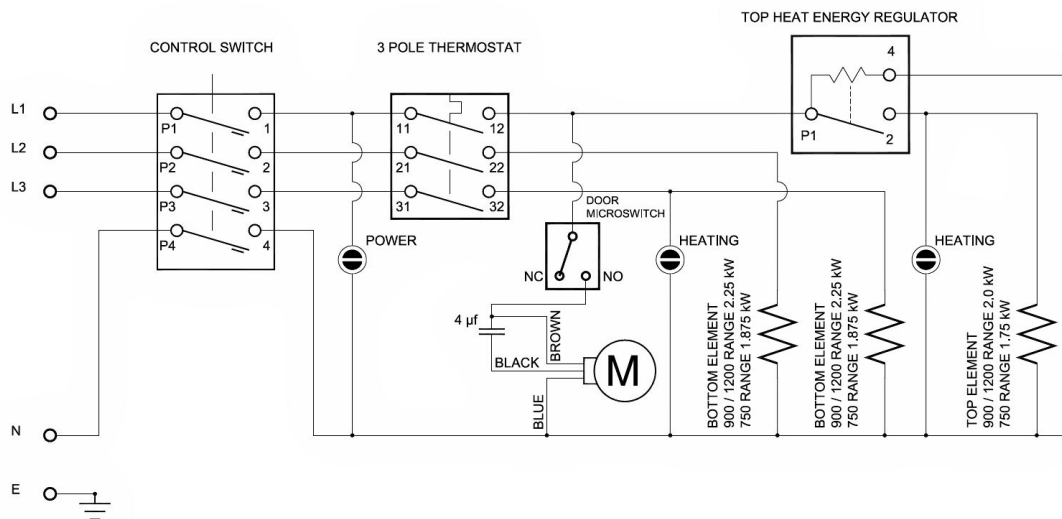

Wiring Connection Between Oven and Hob

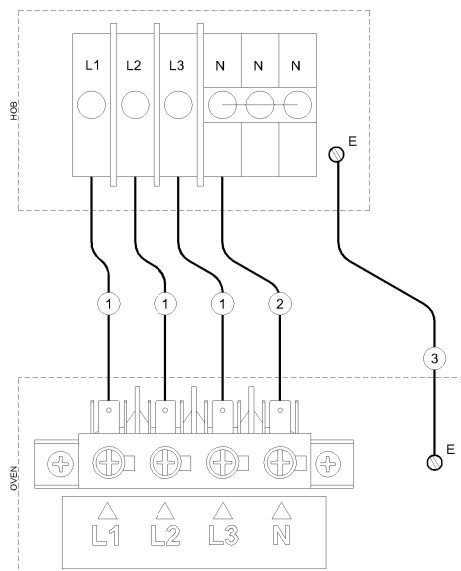

Replacement Parts List

IMPORTANT:

Only genuine authorized replacement parts should be used for the servicing and repair of this appliance. The instructions supplied with the parts should be followed when replacing components.

For further information and servicing instructions, contact your nearest authorized service branch (contact details are as shown on the reverse of the front cover of this manual).

When ordering replacement parts, please quote the part number and the description as listed below. If the part required is not listed below, request the part by description and quote model number and serial number which is shown on the rating plate.

Cooktop

| | | |
|--------|------------------------|------------|
| 010137 | Element Radiant 2400W. | |
| 012693 | Element Coil 2000W. | |
| 013881 | Element Insulator. | |
| 013880 | Element Plate. | |
| 013989 | Energy Regulator. | |
| 227398 | Control Knob HI/LO. | |
| 227963 | Neon Orange. | |
| 227962 | Neon Green. | |
| 228883 | Spill Tray 450mm | (Cooktop). |

Griddle

| | | |
|--------|---|------------|
| 229022 | Griddle Element. | |
| 011987 | Thermostat 50 - 320°C. | |
| 227399 | Control Knob Thermostat 50°C - 300°C - Griddle. | |
| 228288 | Grease Tray | (Griddle). |
| 227963 | Neon Orange. | |
| 227962 | Neon Green. | |
| 229109 | Griddle Plate 300mm. | |
| 229107 | Griddle Plate 600mm. | |
| 229108 | Griddle Plate 900mm. | |

Replacement Parts List

Oven

| | |
|--------|--|
| 228082 | Oven Top Element 2kW. |
| 228059 | Oven Bottom Element 4.5kW. |
| 228704 | Door Spring Kit. (Includes 2 Springs). |
| 229021 | Terminal Block Mains. |
| 229146 | Thermostat 50 - 300°C. |
| 227963 | Neon Orange. |
| 227962 | Neon Green. |
| 013989 | Energy Regulator. |
| 227398 | Control Knob HI/LO Heat. |
| 227399 | Control Knob Thermostat 50°C - 300°C. |

Convection Oven Only

| | |
|---------|---|
| 228938 | Oven Door Microswitch. |
| 230075 | Oven Microswitch Insulator. |
| 010909 | Motor Capacitor 4µf. |
| 228116 | Fan. |
| 019479K | Motor Kit. (Includes Cooling Disc & Capacitor 4µf). |
| 010866 | Cooling Disc. |
| 227399 | Control Knob Thermostat 50°C - 300°C. |

General

| | |
|--------|-------------------------|
| 227892 | Oven Side Rack LH. |
| 227893 | Oven Side Rack RH. |
| 227896 | Oven Rack. |
| 227850 | Adjustable Leg (150mm). |
| 228571 | Index Mark Moulding. |

Accessories

| | |
|--------|---|
| 228566 | Griddle Scraper Tool. |
| 228567 | Smooth Plate Scraper Blades (Pack of 5 Blades). |
| 229674 | Rear Roller Kit. |
| 228799 | 900 mm Plinth Kit. |

