



OEM6[®] Family

OEM615, OEM617, OEM617D, OEM628 and OEM638 cards
and
FlexPak6 and FlexPak6D enclosures

Installation and Operation User Manual

OEM6 Family - Installation and Operation User Manual

Publication Number: OM-20000128
Revision Level: 12
Revision Date: October 2016

To download the latest firmware and/or software visit: www.novatel.com/support/firmware-downloads.

This manual reflects firmware version 6.710/OEM0607100RN000

Warranty

NovAtel® Inc. warrants that its GNSS products are free from defects in materials and workmanship, subject to the conditions set forth on our web site: www.novatel.com/products/warranty/.

OEM6® Card Receivers	One (1) Year
FlexPak6™ and FlexPak6D™	One (1) Year
GPS Antenna Series	One (1) Year
Cables and Accessories	Ninety (90) Days
Software Warranty	One (1) Year

Return Instructions

To return products, refer to the instructions found under the Return Policy Tab on the warranty page: www.novatel.com/products/warranty/.

Proprietary Notice

Information in this document is subject to change without notice and does not represent a commitment on the part of NovAtel Inc. The software described in this document is furnished under a license agreement or non-disclosure agreement. The software may be used or copied only in accordance with the terms of the agreement. It is against the law to copy the software on any medium except as specifically allowed in the license or non-disclosure agreement.

The information contained within this manual is believed to be true and correct at the time of publication.

OEM6, ALIGN, SPAN and NovAtel are registered trademarks of NovAtel Inc.

FlexPak6, FlexPak6D, OEM615, OEM617, OEM617D, OEM628, OEM638, GLIDE, OEMV-1, OEMV-2, OEMV-3, NovAtel CORRECT and NovAtel Connect are trademarks of NovAtel Inc.

All other brand names are trademarks of their respective holders.

Manufactured and protected under U.S. patents.

#5,101,416	#6,184,822 B1
#5,390,207	#6,243,409 B1
#5,414,729	#6,445,354 B1
#5,495,499	#6,608,998 B1
#5,736,961	#6,664,923 B1
#5,809,064	#7,738,536

© Copyright 2016 NovAtel Inc. All rights reserved.
Unpublished rights reserved under International copyright laws.

Table of Contents

Notices	13
FCC Notices	13
Industry Canada	13
CE Marking	14
WEEE	14
RoHS	14
REACH	14
Ethernet Port	14
Lightning Protection Installation and Grounding Procedure	15
Conventions	17
Customer Support	18
NovAtel Knowledge Base	18
Before Contacting Customer Support	18
Contact Information	18
1 Introduction	19
1.1 Overview of the OEM6 Family of Cards and Enclosures	19
1.1.1 OEM6 Family Receiver Cards	19
1.1.2 OEM6 Receiver Enclosure	19
1.2 Related Documents and Information	19
1.2.1 OEM615 Receiver	20
1.2.2 OEM617 Receiver	20
1.2.3 OEM617D Receiver	21
1.2.4 OEM628 Receiver	21
1.2.5 OEM638 Receiver	22
1.3 OEM6 Receiver System Overview	23
1.3.1 OEM6 Family Card	24
1.3.2 Enclosure	24
1.3.3 GNSS Antenna	25
1.3.4 Power Supply	25
1.3.5 Optional External Frequency Reference	25
1.3.6 Data Communications Equipment	25
1.3.7 Onboard Memory	25
1.4 OEM6 Enclosures	26
1.4.1 FlexPak6	26
1.4.2 FlexPak6D	27
2 Installation OEM6 Family Cards	28
2.1 Shipping Box	28
2.2 Additional Equipment Required	28
2.3 Selecting a GNSS Antenna	29
2.3.1 Choosing a Coaxial Cable	29
2.3.2 Mounting the GNSS Antenna	29
2.3.3 Connecting the Antenna to the Receiver	30
2.4 Power Supply Requirements	31
2.5 Card Installation Overview	32
2.5.1 Installing an OEM6 Family Card with Wiring Harness and Enclosure	32
2.5.2 Applying Power to the Receiver	38
2.5.3 Connecting Data Communications Equipment	38
2.6 OEM638 Card Security	43
2.6.1 Administration Password	43

2.6.2 FTP Server and ICOM Port	43
2.7 Installing NovAtel PC Utilities	43
3 Installation FlexPak6 & FlexPak6D Enclosures.....	44
3.1 Shipping Box	44
3.2 Additional Equipment Required	44
3.3 Selecting a GNSS Antenna	44
3.3.1 Choosing a Coaxial Cable	45
3.3.2 Mounting the GNSS Antenna	45
3.3.3 FlexPak6 and FlexPak6D Alternative Power Source	47
3.3.4 Battery Backup	49
3.3.5 FlexPak6 Status Indicators and Connector Labels.....	49
3.3.6 FlexPak6D Status Indicators and Connector Labels	50
3.4 Installing NovAtel PC Utilities	50
4 Operation OEM6 Cards and Enclosures	51
4.1 Communications with the Receiver	51
4.1.1 Serial Ports	52
4.1.2 Communicating with a Remote Terminal.....	53
4.1.3 Communicating with a Computer	53
4.2 Getting Started	54
4.2.1 Starting the Receiver	54
4.2.2 Communicating with the Receiver Using NovAtel Connect.....	54
4.3 Transmitting and Receiving Corrections	55
4.3.1 Base Station Configuration.....	57
4.3.2 Rover Station Configuration	59
4.3.3 ALIGN® Heading Master and Remote Configurations	59
4.3.4 PDP and GLIDE™ Configurations.....	60
4.4 STEADYLINE®	60
4.4.1 Maintain	61
4.4.2 Transition	61
4.4.3 Prefer Accuracy	62
4.4.4 UAL.....	62
4.5 Configuration Notes.....	64
4.6 Enabling SBAS Positioning	64
4.7 Enabling L-Band.....	65
4.7.1 TerraStar Subscriptions.....	65
4.7.2 Veripos Subscriptions.....	66
4.7.3 OmniSTAR®.....	66
4.8 RTK ASSIST™	67
4.9 Transferring Time Between Receivers	68
4.9.1 GPS to Receiver Time Synchronization	68
4.9.2 Time Definitions.....	68
4.9.3 Procedures to Transfer Time.....	69
4.10 Additional Features and Information (Card and Enclosure)	73
4.10.1 Universal Serial Bus (USB)	73
4.10.2 CAN Bus (not available on the FlexPak6D).....	74
4.10.3 Strobes	75
4.10.4 Status Indicator.....	75
4.10.5 External Oscillator	76
4.10.6 Antenna LNA Power	77
4.10.7 Ethernet	77
4.11 Logging and Retrieving Data Overview	78
4.11.1 Onboard Memory.....	78
4.11.2 Remote Logging Initiation.....	78

4.11.3 Manual Retrieval of Logged Data	78
4.11.4 Remote Retrieval of Logged Data	78
4.11.5 Naming Logs	79
4.11.6 Manual Log File Naming.....	79
4.11.7 Stop Logging	79
4.11.8 Reading Data and Post-Processing	79
4.11.9 Pass-Through Logging	80
5 Built-In Status Tests.....	81
5.1 Overview	81
5.2 Receiver Status Word	81
5.3 Error Strobe Signal.....	82
5.4 RXSTATUSEVENT Log	82
5.5 RXSTATUS Log	82
5.5.1 Overview.....	82
5.5.2 Error Word.....	83
5.5.3 Status Code Arrays	83
5.5.4 Receiver Status Code.....	84
5.5.5 Auxiliary Status Codes	84
5.5.6 Set and Clear Mask for all Status Code Arrays.....	84
5.6 Status LED	84
6 Ethernet Configuration	86
6.1 Required Hardware	86
6.2 Static IP Address Configuration	87
6.2.1 Static IP Address Configuration—Receiver.....	88
6.2.2 Static IP Address Configuration—Windows 7	89
6.2.3 Confirming Ethernet Setup	90
6.3 Dynamic IP Address Configuration	91
6.4 Base/Rover Configuration through Ethernet Connectivity.....	93
6.5 Large COM Port Data Throughput.....	95
6.6 NTRIP Configuration	96
7 Troubleshooting.....	98
7.1 Examining the RXSTATUS Log	99
7.2 Examining the AUX1 Status Word	101
8 NovAtel Firmware and Software	102
8.1 Firmware Updates and Model Upgrades.....	102
8.1.1 Firmware Updates	102
8.1.2 Model Upgrades	102
8.2 Authorization Code.....	103
8.3 Updating or Upgrading Using the WinLoad Utility.....	104
8.3.1 Transferring Firmware Files.....	104
8.3.2 Using the WinLoad Utility	104
8.4 Updating Using SoftLoad Commands.....	106
8.4.1 SoftLoad Commands and Logs	106
8.4.2 Working With S-Records	107
8.4.3 Sending Firmware Data.....	107
8.4.4 SoftLoad Update Method.....	109
8.4.5 Firmware Update Using FTP or USB Mass Storage Device	111
8.4.6 SoftLoad Direct Commands and Logs.....	111
8.4.7 SoftLoad Direct Update Method	111
8.4.8 SoftLoad Errors	112
8.5 Upgrading Using the AUTH Command	112
8.5.1 Upgrade Procedure	112

A OEM615 Technical Specifications	113
A.1 OEM615 Receiver	113
A.1.1 Physical Description.....	114
A.2 Top-view, P1101 Main Connector 20-Pin Header	121
A.2.1 Logic-Level I/O.....	122
A.2.2 CAN Interface.....	123
A.2.3 USB Interface.....	124
B OEM617 Technical Specifications	125
B.1 OEM617 Receiver	125
B.1.1 Physical Description.....	126
B.1.2 Logic-Level I/O.....	132
B.1.3 CAN Interface.....	133
B.1.4 USB Interface.....	134
C OEM617D Technical Specifications	135
C.1 OEM617D Receiver	135
C.1.1 Physical Description.....	136
C.1.2 Logic-Level I/O.....	142
C.1.3 CAN Interface.....	143
C.1.4 USB Interface.....	144
D OEM628 Technical Specifications.....	145
D.1 OEM628 Receiver	145
D.1.1 Physical Description.....	146
D.1.2 CMOS Level I/O.....	156
D.1.3 CAN Interface	157
D.1.4 USB Interface.....	158
D.1.5 Ethernet Port.....	159
E OEM638 Technical Specifications.....	162
E.1 OEM638 Receiver	162
E.1.1 Physical Description.....	163
E.1.2 Power Supply	181
E.1.3 Antenna Power Output.....	181
E.1.4 Logic-Level I/O	182
E.1.5 Communication Ports.....	183
E.1.6 CAN Interfaces.....	184
E.1.7 USB Interfaces	185
E.1.8 Ethernet Port.....	187
E.1.9 System Performance.....	188
F FlexPak6 Technical Specifications.....	190
F.1 FlexPak6	190
G FlexPak6D Technical Specifications	194
G.1 FlexPak6D	194
H Enclosure Cables Technical Specifications.....	198
H.1 FlexPak6 and FlexPak6D Cables.....	198
H.1.1 I/O Breakout Cable (NovAtel part number 01018649).....	198
H.1.2 I/O DB-HD15 Strobe Port Cable (NovAtel part number 01018651).....	199
H.1.3 Straight Through Serial Cable (NovAtel part number 01018520).....	200
H.1.4 Null Modem Cable (NovAtel part number 01017658).....	201
H.1.5 12 V Power Accessory Cable (NovAtel part number 01017663).....	202
H.1.6 FlexPak6D SMA to TNC Adapter Cable (NovAtel part number 60723154).....	203

I Accessories and Replacement Parts	204
I.1 OEM6 Receiver Cards	204
I.2 FlexPak6 and FlexPak6D.....	204
I.3 Accessories	204
I.4 Manufacturers' Part Numbers	205
J Electrostatic Discharge (ESD) Practices.....	206
J.1 Overview.....	206
J.2 Handling ESD Sensitive Devices.....	206
J.3 Prime Static Accumulators	207
J.4 Handling Printed Circuit Boards	207

Tables

Table 1: FlexPak6 Features	26
Table 2: FlexPak6D Features	27
Table 3: Voltage Input Requirement for OEM6 Family Cards.....	31
Table 4: OEM6 Card Default Serial Port Configurations.....	39
Table 5: Fuse/Holder Recommendations-12 V System	48
Table 6: FlexPak6 Status Indicators and Connector Labels	49
Table 7: FlexPak6D Status Indicators and Connector Labels	50
Table 8: FlexPak6 and FlexPak6D Default Serial Port Configuration	50
Table 9: Serial Ports Supported	52
Table 10: Available USB Signals on Receivers	73
Table 11: Troubleshooting Based on Symptoms	98
Table 12: Resolving a Receiver Error Word.....	99
Table 13: Resolving an Error in the Receiver Status Word.....	100
Table 14: Resolving an Error in the AUX1 Status Word	101
Table 15: OEM615 Strokes	120
Table 16: OEM615 Strobe Electrical Specification	120
Table 17: Bill of Materials (critical components).....	123
Table 18: Bill of Materials (critical components).....	124
Table 19: Bill of Materials.....	124
Table 20: OEM617 Strokes	130
Table 21: OEM617 Strobe Electrical Specification	130
Table 22: Bill of Materials (critical components).....	133
Table 23: Bill of Materials (critical components).....	134
Table 24: Bill of Materials.....	134
Table 25: OEM617D Strokes.....	140
Table 26: OEM617D Strobe Electrical Specification.....	140
Table 27: Bill of Materials (critical components).....	143
Table 28: Bill of Materials (critical components).....	144
Table 29: Bill of Materials.....	144
Table 30: OEM628 Strokes	153
Table 31: OEM628 Strobe Electrical Specifications	153
Table 32: ESD Critical Components	156
Table 33: CAN Critical Components	157
Table 34: USB Critical Components	158
Table 35: Ethernet Transformer Characteristics	160
Table 36: Bill of Materials (critical components).....	160
Table 37: OEM638 Strokes	169
Table 38: OEM638 Strobe Electrical Specifications	170
Table 39: J4101 Expansion Header Pin-Out and Signal Description (even numbered pins).....	178
Table 40: 3.3V CMOS Electrical Characteristics (-40 to 85°C).....	181
Table 41: Bill of Materials (critical components).....	183
Table 42: Bill of Materials (critical components).....	184
Table 43: Bill of Materials.....	186
Table 44: Recommended Ethernet Transformer Characteristics.....	188
Table 45: Bill of Materials (Critical Components Only).....	188
Table 46: FlexPak6 Port Pin-Out Descriptions	191
Table 47: FlexPak6 I/O Port Pin-Out Descriptions.....	192

Table 48: FlexPak6 Strobe Electrical Specifications.....	193
Table 49: FlexPak6D Port Pin-Out Descriptions	195
Table 50: FlexPak6D I/O Port Pin-Out Descriptions	196
Table 51: FlexPak6D Strobe Electrical Specifications	197
Table 52: I/O Breakout Cable Wiring.	198
Table 53: I/O Strobe Port Cable Wiring	199
Table 54: Null Modem Cable Wiring	201
Table 55: Static-Accumulating Materials.....	207

Figures

Figure 1: OEM615 Receiver Board.....	20
Figure 2: OEM617 Receiver Board.....	20
Figure 3: OEM617D Receiver Board.....	21
Figure 4: OEM628 Receiver Board.....	21
Figure 5: OEM638 Receiver Board.....	22
Figure 6: OEM615, OEM617, OEM617D and OEM628 Receiver System.....	23
Figure 7: OEM638 Receiver System.....	24
Figure 8: FlexPak6.....	26
Figure 9: FlexPak6D.....	27
Figure 10: OEM615 Connector and Indicator Locations.....	35
Figure 11: OEM617 Connector and Indicator Locations.....	36
Figure 12: OEM617D Connectors and Indicators.....	36
Figure 13: OEM628 Connector and Indicator Locations.....	37
Figure 14: OEM638 Connector and Indicator Locations.....	38
Figure 15: COM3 and USB Multiplexed on OEM615, OEM617 and OEM617D.....	40
Figure 16: OEM628 COM3 Multiplexed with EVENT2 and USERGPIO.....	41
Figure 17: OEM638 Multiplexed Pin Options.....	42
Figure 18: FlexPak6 Installation.....	46
Figure 19: FlexPak6D Installation.....	46
Figure 20: FlexPak6 Connectors.....	49
Figure 21: FlexPak6 Connectors.....	50
Figure 22: Basic OEM6 Family Card Connection Interfaces (example).....	51
Figure 23: Basic Differential Setup.....	56
Figure 24: Positioning Change Without STEADYLINE.....	61
Figure 25: STEADYLINE Maintain.....	61
Figure 26: STEADYLINE Transition.....	61
Figure 27: STEADYLINE Prefer Accuracy.....	62
Figure 28: STEADYLINE UAL- Warning Limit Example.....	63
Figure 29: STEADYLINE UAL - Out of Bounds Example.....	63
Figure 30: Transfer COARSE Time from Fine Clock to Cold Clock Receiver.....	69
Figure 31: Transfer FINE Time from Fine Clock to Cold Clock Receiver.....	70
Figure 32: Transfer FINE Time from Fine Clock to Warm Clock Receiver.....	71
Figure 33: 1 PPS Alignment.....	72
Figure 34: Location of Receiver Status Word.....	82
Figure 35: Reading the Bits in the Receiver Status Word.....	82
Figure 36: Location of Receiver Error Word.....	83
Figure 37: Reading the Bits in the Receiver Error Word.....	83
Figure 38: Status LED Flash Sequence Example.....	85
Figure 39: Cross-Over Ethernet Cable Configuration—OEM628 and OEM638.....	87
Figure 40: Cross-Over Ethernet Cable Configuration—FlexPak6.....	88
Figure 41: Dynamic IP Address Configuration through a DHCP Server—OEM628 and OEM638.....	91
Figure 42: Dynamic IP Address Configuration through a DHCP Server—FlexPak6.....	92
Figure 43: Base/Rover Ethernet Setup—OEM628 and OEM638.....	94
Figure 44: Base/Rover Ethernet Setup—FlexPak6.....	94
Figure 45: NTRIP System.....	96
Figure 46: WinLoad's Open Window.....	104
Figure 47: Open File in WinLoad.....	105

Figure 48: COM Port Setup	105
Figure 49: Searching for Card.....	105
Figure 50: Authorization Code Window	105
Figure 51: Upgrade Process Complete.....	106
Figure 52: OEM615 Board Dimensions	114
Figure 53: OEM615 Keep-Out Zone	115
Figure 54: OEM615V Board Dimensions	116
Figure 55: OEM615V Keep-Out Zone.....	117
Figure 56: OEM615 ESD Protection for EVENT and PPS Strobes Schematic.....	122
Figure 57: OEM615 PV LED Drive Buffer Schematic	123
Figure 58: OEM615 CAN Transceiver Implementation Schematic.....	123
Figure 59: OEM615 USB Implementation Schematic.....	124
Figure 60: OEM617 Board Dimensions	126
Figure 61: OEM617 Keep-Out Zone	127
Figure 62: Top-view, P1101 Main Connector 20-Pin Header	131
Figure 63: OEM617 ESD Protection for EVENT and PPS Strobes Schematic.....	132
Figure 64: OEM617 PV LED Drive Buffer Schematic	133
Figure 65: OEM617 CAN Transceiver Implementation Schematic.....	133
Figure 66: OEM617 USB Implementation Schematic.....	134
Figure 67: OEM617D Board Dimensions.....	136
Figure 68: OEM617D Keep-Out Zone	137
Figure 69: Top-view, P1101 Main Connector 20-Pin Header	141
Figure 70: OEM617D ESD Protection for EVENT and PPS Strobes Schematic.....	142
Figure 71: OEM617D PV LED Drive Buffer Schematic.....	143
Figure 72: OEM617D CAN Transceiver Implementation Schematic	143
Figure 73: OEM617D USB Implementation Schematic	144
Figure 74: OEM628 Board Dimensions	146
Figure 75: OEM628 Keep-Out Zone	147
Figure 76: OEM628V Board Dimensions.....	148
Figure 77: OEM628V Keep-Out Zone.....	149
Figure 78: Top-view, P1500 Main Connector 24-Pin Header	154
Figure 79: Top-view, P1502 Expansion 16-Pin Header.....	155
Figure 80: OEM628 ESD Protection for EVENT and PPS Strobes Schematic.....	156
Figure 81: OEM628 LED Drive Buffer for ERROR and PV Signals Schematic	157
Figure 82: OEM628 CAN Transceiver Implementation Schematic.....	157
Figure 83: OEM628 USB Implementation Schematic.....	158
Figure 84: Ethernet Reference Schematic	159
Figure 85: Ethernet LED Buffer Schematic.....	161
Figure 86: OEM638 Dimensions.....	163
Figure 87: OEM638 and OEM638V Keep-Out Zone	164
Figure 88: P4001 Main Header Pin-Out and Signal Description.....	171
Figure 89: J3201 Ethernet Header Pin-Out and Signal Description.....	174
Figure 90: J4101 Expansion Header Pin-Out and Signal Description (odd numbered pins).....	175
Figure 91: Example - ESD Protection for Strobes (optional buffering for PPS).....	182
Figure 92: Example - LED Drive Buffer for PV and ERROR Signals.....	183
Figure 93: Example - CAN Protection and Filtering Circuit.....	184
Figure 94: Example - Connecting HSUSB0 to a Micro-B Type USB Connector.....	185
Figure 95: Example – Connecting HSUSB1 or HSUSB2 to a Micro-AB Type USB Connector.....	186
Figure 96: Example - Ethernet Reference Schematic.....	187
Figure 97: FlexPak6 Dimensions	191

Figure 98: FlexPak6D Dimensions	195
Figure 99: I/O Breakout Cable	198
Figure 100: I/O DB-HD15 Strobe Port Cable	199
Figure 101: Straight Through Serial Cable	200
Figure 102: Null Modem Cable	201
Figure 103: 12 V Power Accessory Cable	202
Figure 104: FlexPak6D SMA to TNC Adapter Cable	203

Notices

The following notices apply, as appropriate, to the OEM6 family products including the OEM615, OEM617, OEM617D, OEM628 and OEM638 as well as the FlexPak6 and FlexPak6D enclosures.



Changes or modifications to this equipment, not expressly approved by NovAtel Inc., could result in violation of FCC, Industry Canada and CE Marking rules and void the user's authority to operate this equipment.

FCC Notices

This device complies with part 15 of the FCC Rules. Operation is subject to the following two conditions: (1) this device may not cause harmful interference, and (2) this device must accept any interference received, including interference that may cause undesired operation.

The FlexPak6 has been tested and found to comply with the radiated and conducted emission limits for a Class B digital device. The Class B limits are designed to provide reasonable protection against harmful interference in a residential installation.

The FlexPak6D has been tested and found to comply with the radiated and conducted emission limits for a Class A digital device. The Class A limits are designed to provide reasonable protection against harmful interference in a residential installation.

The equipment listed generates, uses, and can radiate radio frequency energy and, if not installed and used in accordance with the instructions, may cause harmful interference to radio communications. However, there is no guarantee that interference will not occur in a particular installation. If this equipment does cause harmful interference to radio or television reception, which can be determined by turning the equipment off and on, the user is encouraged to try to correct the interference by one or more of the following measures:

- Reorient or relocate the receiving antenna
- Increase the separation between the equipment and the receiver
- Connect the equipment to an outlet on a circuit different from that to which the receiver is connected
- Consult the dealer or an experienced radio/TV technician for help



For the FlexPak6 only, to maintain compliance with the limits of a Class B digital device, you must use properly shielded interface cables (such as Belden #9539 or equivalent) when using the serial data ports, and double-shielded cables (such as Belden #9945 or equivalent) when using the I/O strobe port.

Industry Canada

FlexPak6 Class B digital apparatus comply with Canadian ICES-003.

FlexPak6 appareil numérique de la classe B est conforme à la norme NMB-003 du Canada.

CE Marking

Hereby, NovAtel Inc. declares that FlexPak6/FlexPak6D are in compliance with the essential requirements (radio performance, electromagnetic compatibility and electrical safety) and other relevant provisions of Directive 1999/5/EC, EMC Directive 2004/108/EC, and the RoHS Recast Directive 2011/65/EU. Therefore the equipment is labeled with the following CE-marking.



The Declaration of Conformity may be obtained from NovAtel Inc., 1120-68th Ave N.E., Calgary, Alberta, Canada. T2E-8S5.

WEEE

If you purchased your OEM6 family product in Europe, please return it to your dealer or supplier at the end of life. The objectives of the European Community's environment policy are, in particular, to preserve, protect and improve the quality of the environment, protect human health and utilise natural resources prudently and rationally. Sustainable development advocates the reduction of wasteful consumption of natural resources and the prevention of pollution. Waste Electrical and Electronic Equipment (WEEE) is a regulated area. Where the generation of waste cannot be avoided, it should be reused or recovered for its material or energy.

WEEE products may be recognized by their wheeled bin label ().¹

RoHS

The OEM6 family and FlexPak6 are compliant with the European Union (EU) Restriction of Hazardous Substances (RoHS) Directive 2011/65/EU.

REACH

NovAtel strives to comply with the EU Directive EC 1907/2006 on chemicals and their safe use as per the Registration, Evaluation, Authorization and Restriction of Chemical substances (REACH) for its products, including the OEM6 family products. Since REACH SVHC lists are updated occasionally, please contact NovAtel Customer Support if you require further information.

Ethernet Port



The Ethernet ports are Safety Extra Low Voltage (SELV) circuits only and are suitable for connection within a building only. Do not connect them to Telephone Network Voltage (TNV) circuits.

1. See www.novatel.com/products/compliance/environmental-compliance/ for more information.

Lightning Protection Installation and Grounding Procedure

What is the hazard?

A lightning strike into the ground causes an increase in the earth's potential which results in a high voltage potential between the center conductor and shield of the coaxial cable. This high voltage develops because the voltage surge induced onto the center conductor lags in time behind the voltage surge induced onto the shield.

Hazard Impact

A lightning strike causes the ground potential in the area to rise to dangerous levels resulting in harm to personnel or destruction of electronic equipment in an unprotected environment. It also conducts a portion of the strike energy down the inner conductor of the coax cable to the connected equipment.



Only qualified personnel, such as electricians mandated by the governing body in the country of installation, may install lightning protection devices.

Actions to Mitigate Lightning Hazards

1. Do not install antennas or antenna coaxial cables outside the building during a lightning storm.
2. It is not possible to avoid over voltages caused by lightning, but a lightning protection device may be used to shunt a large portion of the transient energy to the building ground, reducing the over voltage condition as quickly as possible.
3. Primary lightning protection must be provided by the operator/customer according to local building codes as part of the extra building installation.
4. To ensure compliance with clause 7 "Connection to Cable Distribution Systems" of EN 60950-1, Safety for Information Technology Equipment, a secondary lightning protection device must be used for in-building equipment installations with external antennas. The following device has been approved by NovAtel Inc.:

Polyphaser - Surge Arrester DGXZ+24NFNF-B

If this device is not chosen as the primary lightning protection device, the device chosen must meet the following requirements:

- UL listed, or equivalent, in country of installation (for example, TUV, VDE and so on) for lightning surge protection
 - The primary device must be capable of limiting an incoming surge to 10 kV
5. The shield of the coaxial cable entering the building should be connected at a grounding plate at the building's entrance. The lightning protection devices should have their chassis grounded to the same ground near to the building's entrance.
 6. The primary and secondary lightning protections should be as close to the building's entrance as possible. Where feasible, mount onto the grounding plate itself (refer to the figure below).

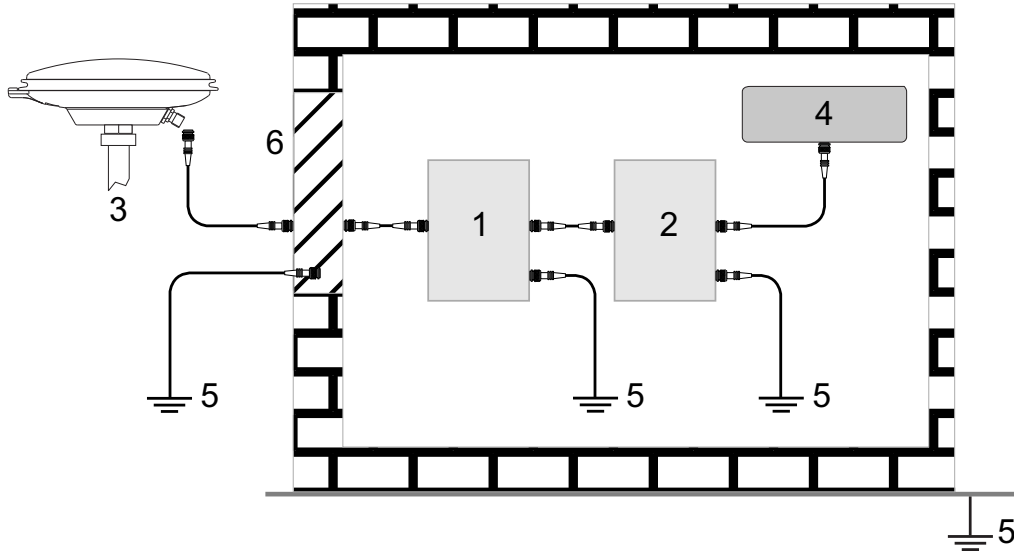

Ref #	Description	Ref #	Description
1	Primary lightning protection device	4	GNSS Receiver
2	Secondary lightning protection device	5	To ground
3	External antenna	6	Grounding plate or grounding point at the building's entrance

i Acceptable choices for earth grounds, for central buildings, are:

- Grounded interior metal cold water pipe within five feet (1.5 m) of the point where it enters the building
- Grounded metallic service raceway
- Grounded electrical service equipment enclosure
- Eight-foot grounding rod driven into the ground (only if bonded to the central building ground by #6, or heavier, bonding wire)

These installation instructions are the minimum requirements for receiver and antenna installations. Where applicable, follow the electrical codes for the country of installation. Examples of country codes include:

- USA National Electrical Code (NFPA 70)
- Canada Canadian Electrical Code (CSA C22)
- UK British Standards Institute (BSI 7671)

Conventions

The following conventions are used in this manual:



Information that supplements or clarifies text.



A caution that actions, operation or configuration may lead to incorrect or improper use of the hardware.



A warning that actions, operation or configuration may result in regulatory noncompliance, safety issues or equipment damage.

615

Specific to the OEM615 card

617

Specific to the OEM617 card

617D

Specific to the OEM617D card

628

Specific to the OEM628 card

638

Specific to the OEM638 card

FPk6

Specific to the FlexPak6 enclosure

FPk6D

Specific to the FlexPak6D enclosure

NovAtel Knowledge Base

If a technical issue occurs, visit the NovAtel support website at www.novatel.com/support/ and search for general information about GNSS and other technologies, information about NovAtel hardware, software, installation and operation issues.

Before Contacting Customer Support

Before contacting NovAtel Customer Support about a firmware problem, perform the following steps:

1. Log the following data to a file on a computer for 15 minutes:

```
RXSTATUSB once
RAWEPHEMB onchanged
RANGEB ontime 1
BESTPOSB ontime 1
RXCONFIGA once
VERSIONA once
```

2. Send the data file to NovAtel Customer Support, using either the NovAtel FTP site at <ftp://ftp.novatel.ca/> or through the support@novatel.com e-mail address.
3. Also issue a `FRESET` command to the receiver to clear any unknown settings.



Note how the receiver is configured before sending the `FRESET` command by logging `RXCONFIGA` once to recall settings. The `FRESET` command erases all user settings and performs a factory reset.

If a hardware problem is encountered, send a list of the troubleshooting steps taken and the results.

Contact Information

Log a support request with NovAtel Customer Support using one of the following methods:

Log a Case and Search Knowledge:

Website: www.novatel.com/support

Log a Case, Search Knowledge and View Your Case History: (login access required)

Web Portal: <https://novatelsupport.force.com/community/login>

E-mail:

support@novatel.com

Telephone:

U.S. and Canada: 1-800-NOVATEL (1-800-668-2835)

International: +1-403-295-4900

1.1 Overview of the OEM6 Family of Cards and Enclosures

The OEM6 family offers Global Navigation Satellite System (GNSS) receivers and integrated L-Band capability. The OEM6 family supports existing and planned GPS, GLONASS, QZSS, BeiDou and Galileo frequencies and is capable of full code and Real-Time Kinematic (RTK) positioning. OEM6 boards are designed for flexibility of integration and configuration. NovAtel enclosures are compact and lightweight and easy to integrate.

For further information about OEM6 receiver boards, refer to the product brochures at www.novatel.com/products/gnss-receivers/.

1.1.1 OEM6 Family Receiver Cards

- OEM615 - refer to *OEM615 Receiver* on page 20 for details
- OEM617 - refer to *OEM617 Receiver* on page 20 for details
- OEM617D - refer to *OEM617D Receiver* on page 21 for details
- OEM628 - refer to *OEM628 Receiver* on page 21 for details
- OEM638 - refer to *OEM638 Receiver* on page 22 for details

1.1.2 OEM6 Receiver Enclosure

- FlexPak6 - refer to *FlexPak6* on page 26 for details
- FlexPak6D - refer to *FlexPak6D* on page 27 for details

1.2 Related Documents and Information

After the OEM6 hardware is operational, the [OEM6 Family Firmware and Reference Manual](#) (OM-20000129) becomes the primary source for command and log information. Each receiver has a specific set of features, such as L-Band or GLONASS support, so some commands and logs may not be supported by your model. Refer also to our web site www.novatel.com/support/ for the latest documentation.

This manual does not cover OEM6 service and repair. Contact a local NovAtel dealer for service or repair inquiries (refer to *Customer Support* on page 18 for contact details).

1.2.1 OEM615 Receiver

The OEM615 has the same form and fit as NovAtel's OEMV-1™ receivers, with the following features:

- Dual-frequency: L1, L2 and L2C for GPS and GLONASS
- Multi-constellation: E1 for Galileo and B1 for BeiDou
- UART LVTTTL and USB communications port
- Smallest form factor
- Low power consumption
- GLIDE, RTK and ALIGN positioning options

Figure 1: OEM615 Receiver Board

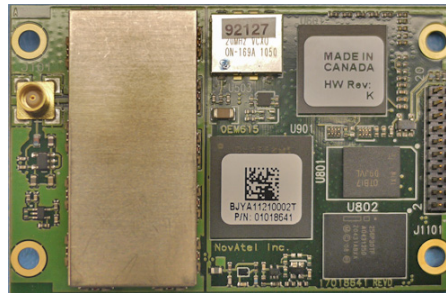

OEM615 technical specifications are provided in *Appendix A, OEM615 Technical Specifications* on page 113.

1.2.2 OEM617 Receiver

The OEM617 has the same form and fit as NovAtel's OEMV-1™ receivers, with the following features:

- Dual-frequency: L1, L2 and L2C for GPS and GLONASS
- Multi-constellation: E1 and E5b for Galileo and B1 and B2 for BeiDou
- UART LVTTTL and USB communications port
- Smallest form factor
- Low power consumption
- GLIDE, RTK and ALIGN positioning options

Figure 2: OEM617 Receiver Board

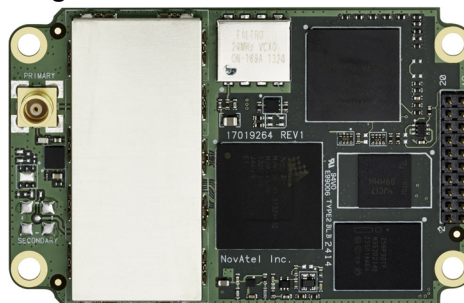

OEM617 technical specifications are provided in *Appendix B, OEM617 Technical Specifications* on page 125.

1.2.3 OEM617D Receiver

The OEM617D has the same form and fit as NovAtel's OEMV-1™ receivers, with the following features:

- Dual antenna, dual-frequency: L1, L2 and L2C for GPS and GLONASS
- Multi-constellation: E1 and E5b for Galileo and B1 and B2 for BeiDou
- Primary and Secondary antennas, UART LVTTTL and USB communications port
- Smallest form factor
- Low power consumption
- RTK with precise ALIGN heading+pitch/roll

Figure 3: OEM617D Receiver Board

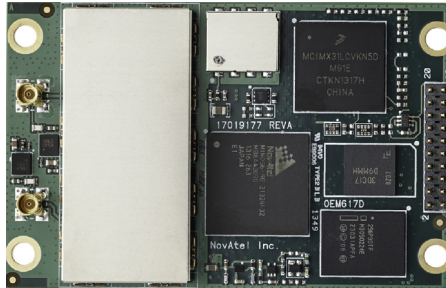

OEM617D technical specifications are provided in *Appendix C, OEM617D Technical Specifications* on page 135. Also refer to the NovAtel application note [APN-071](#) for an explanation of the different models available on NovAtel's OEM617D receiver.

1.2.4 OEM628 Receiver

The OEM628 has the same form and fit as NovAtel's OEMV-2™ receivers, with the following features:

- Triple-frequency/Multi-constellation: GPS L1, L2, L2C, L5; GLONASS L1, L2, L2C; Galileo E1, E5a, E5b, AltBOC; BeiDou B1, B2
- L-Band capability (TerraStar)
- UART RS-232/RS-422 and LVTTTL, USB and Ethernet communications port
- GLIDE, RTK and ALIGN positioning options

Figure 4: OEM628 Receiver Board

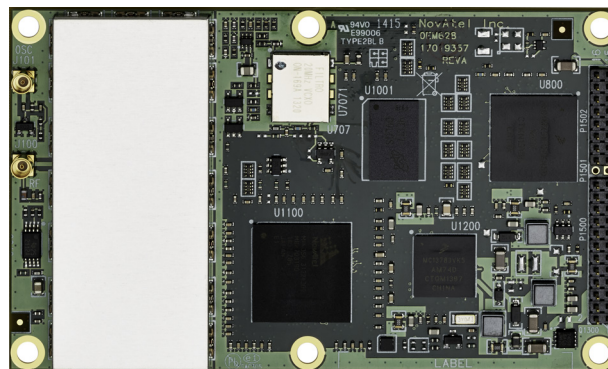

OEM628 technical specifications are provided in *Appendix D, OEM628 Technical Specifications* on page 145.

1.2.5 OEM638 Receiver

The OEM638 has the same form and fit as NovAtel's OEMV-3™ receivers, with the following features:

- Triple-frequency/Multi-constellation: GPS L1, L2, L2C, L5; GLONASS L1, L2, L2C; Galileo E1, E5a, E5b, AltBOC; BeiDou B1, B2
- L-Band capability (TerraStar)
- GLIDE, RTK and ALIGN positioning options
- UART RS-232/RS-422 and LVTTTL, USB device and host and Ethernet communications port
- Onboard data storage

Figure 5: OEM638 Receiver Board

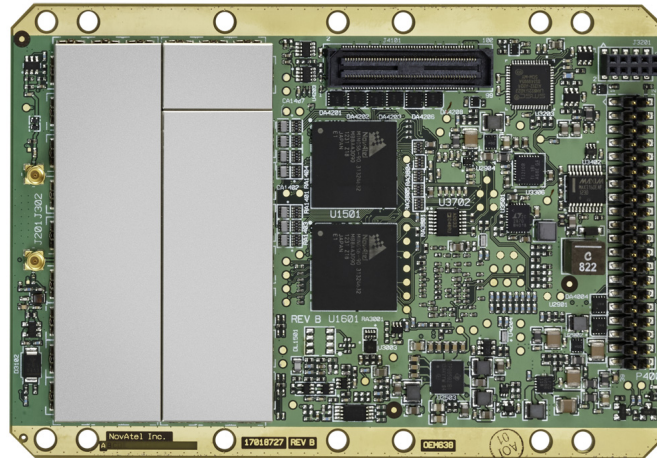

OEM638 technical specifications are provided in *Appendix E, OEM638 Technical Specifications* on page 162.

1.3 OEM6 Receiver System Overview

In addition to the NovAtel OEM6 receiver board, an OEM6 receiver system requires the following:

- Enclosure and wiring harness
- Power supply
- Data communications equipment
- GNSS antenna (and optional Low Noise Amplifier (LNA) power supply)

The overall OEM6 receiver systems are illustrated in *Figure 6, OEM615, OEM617, OEM617D and OEM628 Receiver System* on page 23, *Figure 7, OEM638 Receiver System* on page 24 and described in the sections that follow.

Figure 6: OEM615, OEM617, OEM617D and OEM628 Receiver System

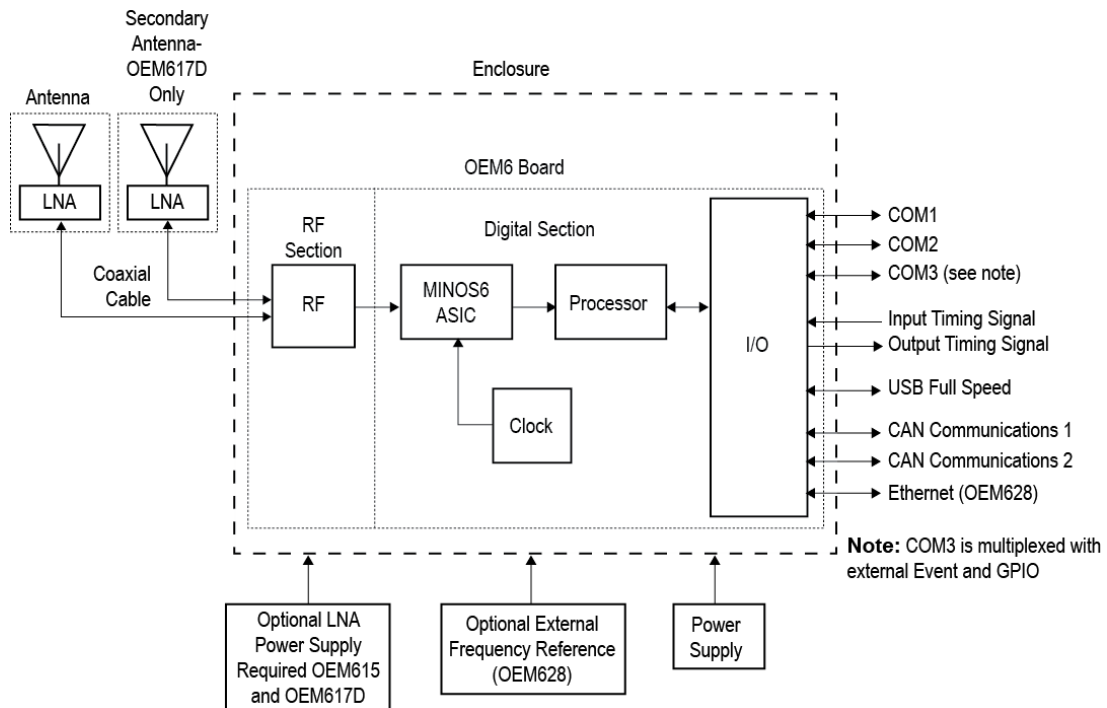
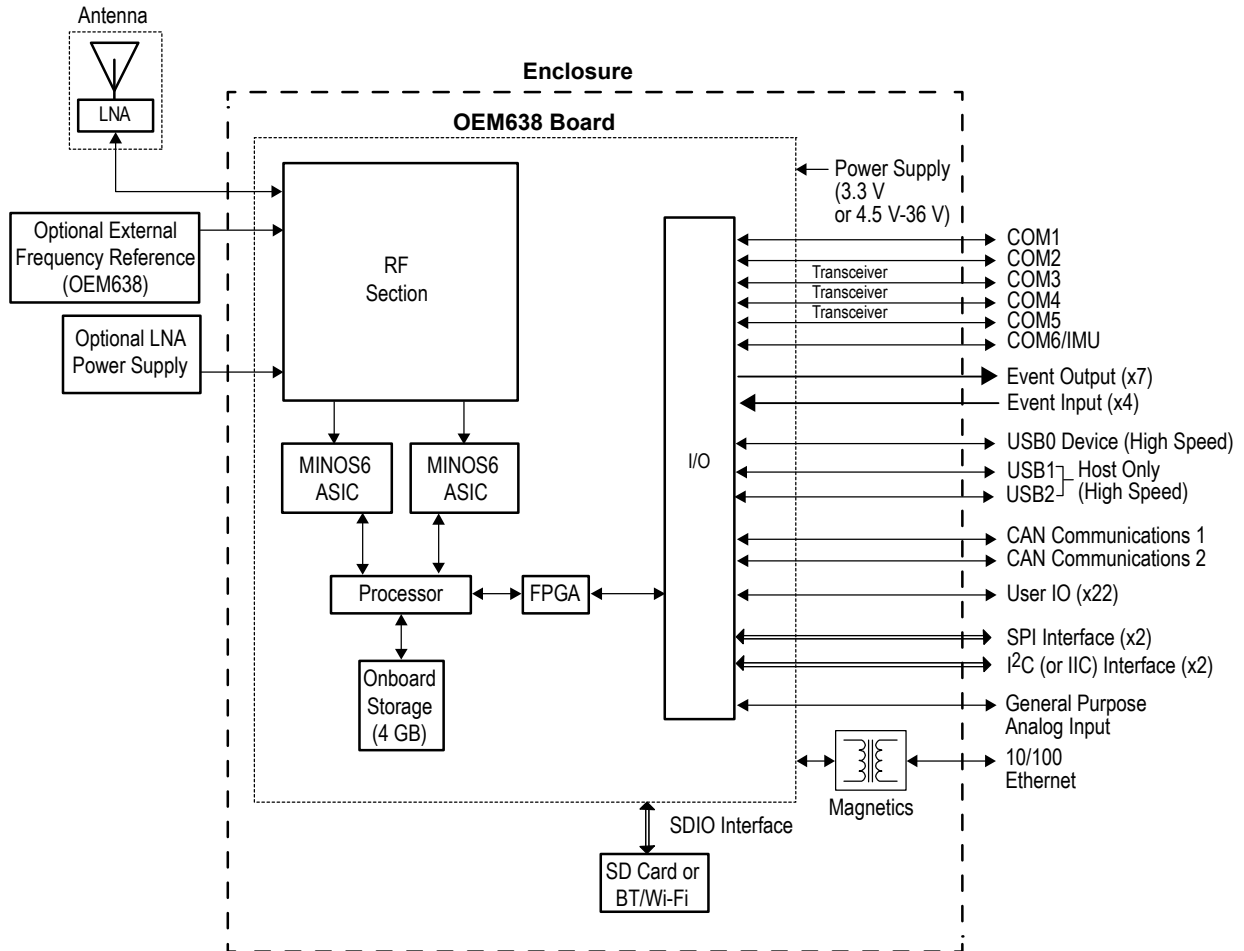

Figure 7: OEM638 Receiver System



1.3.1 OEM6 Family Card

NovAtel's OEM6 family cards consist of a Radio Frequency (RF) section and a digital section.

Radio Frequency (RF) Section

The receiver obtains filtered, amplified GNSS signals from the antenna. The RF section down converts the incoming RF signals to Intermediate Frequency (IF) signals which are processed by the digital section. The RF section also supplies power to the active antenna LNA through the coaxial cable. The RF section has been designed to reject common sources of interference.

Digital Section

The heart of the digital section is NovAtel's MINOS6 ASIC (Application Specific Integrated Circuit). The digital section digitizes and processes the IF signals to obtain a GNSS solution (position, velocity and time). It also processes the system I/O, shown in *Figure 6, OEM615, OEM617, OEM617D and OEM628 Receiver System* on page 23 and *Figure 7, OEM638 Receiver System* on page 24.

1.3.2 Enclosure

An enclosure is necessary to protect the OEM6 family card from environmental extremes and high levels of RF interference.

1.3.3 GNSS Antenna

The antenna converts electromagnetic signals transmitted by GNSS satellites into electrical signals that can be used by the receiver. An active GNSS antenna is normally required for optimal receiver performance. NovAtel's active GNSS antennas provide precise phase centers and robust enclosures (refer to our web site www.novatel.com/antennas).

Optional LNA Power Supply

The receiver can supply power for the antenna LNA. If the antenna is not compatible with the OEM6 power supply, an external LNA supply may be required. See *Antenna LNA Power* on page 77 for more information.

615**617****617D**

An external LNA power supply is required for the OEM615, OEM617 and OEM617D cards.

1.3.4 Power Supply

A power supply capable of delivering the minimum receiver operating voltage and power is required. See *Table 3, Voltage Input Requirement for OEM6 Family Cards* on page 31 and *Appendix A, OEM615 Technical Specifications* on page 113, *Appendix C, OEM617D Technical Specifications* on page 135, *Appendix D, OEM628 Technical Specifications* on page 145 and *Appendix E, OEM638 Technical Specifications* on page 162 for details.

1.3.5 Optional External Frequency Reference

When applications require greater precision than the OEM628 or OEM638 internal clock, connect the OEM628 or OEM638 to an external high stability oscillator. See *External Oscillator* on page 76 for more information.

615**617****617D**

The OEM615, OEM617 and OEM617D do not offer external oscillator capabilities.

1.3.6 Data Communications Equipment

A computer or other data communications device is necessary to communicate with the receiver and to receive and store the data that the receiver provides.

1.3.7 Onboard Memory **638**

The OEM638 has 4 gigabytes of onboard memory for data logging. Refer to *Logging and Retrieving Data Overview* on page 78 for details.

1.4 OEM6 Enclosures

The OEM628 and OEM617D card are also housed in enclosures to provide a complete receiver solution.

The FlexPak6 and FlexPak6D enclosures offer protection against environmental conditions, in addition to the easy to use interface to the card's data, power and status signals.

1.4.1 FlexPak6

NovAtel's FlexPak6 uses the OEM628 card to deliver centimeter level positioning in a compact, lightweight enclosure. The FlexPak6 provides scalable high precision positioning with Ethernet, serial, USB and CAN bus interfaces as well as an Application Program Interface (API) option for supporting custom applications. The FlexPak6 receiver is capable of tracking GPS L1/L2/L2C/L5, GLONASS L1/L2, BeiDou B1/B2 and Galileo E1/E5a/E5b/Alt-BOC signals. *Table 1, FlexPak6 Features* on page 26 lists the features available on the FlexPak6.

Table 1: FlexPak6 Features

Feature	FlexPak6
OEM card	OEM628
Serial ports	2 DB9 connectors
Antenna connector	Single TNC
USB 2.0	Yes
Ethernet, CAN, I/O, Strobe port	DB-HD15 connector
Input (DC) voltage	+6 to +36 V
NovAtel CORRECT™ with PPP ^a	Yes
GPS + GLONASS positioning	Yes
GLIDE™	Yes
ALIGN®	Yes
NovAtel CORRECT™ with RTK	Yes
RAIM	Yes
NTRIP	Yes

- a. A TerraStar subscription is required which is available direct from NovAtel www.novatel.com/products/novatel-correct-ppp/.

For technical specifications on the FlexPak6, see *Appendix F, FlexPak6 Technical Specifications* on page 190. Also refer to the NovAtel application note [APN-071](#) for an explanation of the different models available on NovAtel's FlexPak7D receiver.

Figure 8: FlexPak6



1.4.2 FlexPak6D

NovAtel's compact and lightweight FlexPak6D is scalable to offer sub-metre to centimetre level positioning. Options include RTK for centimetre level real-time positioning, ALIGN[®] for precise heading and relative positioning, GLIDE[™] for decimetre level pass-to-pass accuracy and RAIM for increased GNSS pseudorange integrity. The FlexPak6D provides scalable high precision positioning with serial and USB interfaces as well as an Application Program Interface (API) option for supporting custom applications. The FlexPak6D receiver is capable of tracking GPS L1/L2/L2C, GLONASS L1/L2, BeiDou B1/B2 and Galileo E1 signals. *Table 2, FlexPak6D Features* on page 27 lists the features available on the FlexPak6D.

Table 2: FlexPak6D Features

Feature	FlexPak6D
OEM card	OEM617D
Serial ports	2 DB9 connectors
Dual antenna	2 SMA connectors
USB 2.0	Yes
I/O, Strobe port	DB-HD15 connector
Input (DC) voltage	+6 to +36 V
GPS + GLONASS positioning	Yes
GLIDE [™]	Yes
ALIGN [®]	Yes
NovAtel CORRECT [™] with RTK	Yes
RAIM	Yes
NTRIP	No

For technical specifications on the FlexPak6D, see *Appendix G, FlexPak6D Technical Specifications* on page 194.

Figure 9: FlexPak6D



This chapter provides instructions and guidelines for checking the contents of the shipping box, installing the NovAtel PC utilities on a computer, integrating a NovAtel receiver into a GNSS receiver system similar to that described in *Section 1.3, OEM6 Receiver System Overview* on page 23.



Refer to *Chapter 3, Installation FlexPak6 & FlexPak6D Enclosures* on page 44 for installation instructions.



2.1 Shipping Box

The following items are provided with the OEM6 cards:

- OEM6 family receiver card
- OEM6 Family Receivers Quick Start Guide

2.2 Additional Equipment Required

For the receiver to perform optimally, the following additional equipment is required:

- Interface for power, communications and other signals
- Enclosure to protect against the environment
- GNSS antenna (for a list of NovAtel GNSS antennas refer to our web site www.novatel.com/antennas)
- Coaxial cable (and interconnect adapter cable, as necessary)
- Data communication equipment capable of serial, USB or Ethernet communication
- Serial, USB or Ethernet data cable (if one is not included with the receiver)
- Power supply
- Power cable (if one is not included with the receiver)
- Optional NovAtel OEM6 Development Kit (01018849) (contact www.novatel.com/support for instructions on using the OEM6 Development Kit with the OEM638 receiver card).



When the OEM6 family receiver is installed in a permanent location, it should be protected by a lightning protection device according to local building codes (refer to the *Lightning Protection Installation and Grounding Procedure* on page 15).



Emissions

OEM6 family products have been designed and tested to meet regulatory emission limits. Emission levels may be higher for OEM6 family card level operation than for integrated enclosure level products, like the FlexPak6, using an OEM6 family card.

The OEM615, 628 and 638 cards emission status is Class B. The OEM617 and OEM617D is Class A.

2.3 Selecting a GNSS Antenna

An active antenna with an LNA is required to boost the power of the incoming signal to compensate for the line loss between the antenna and the receiver.

NovAtel offers a variety of antennas, including single and dual-frequency, triple-band and wide-band reference GNSS antennas (refer to our web site: www.novatel.com/antennas for details of available antennas). All antennas include band pass filtering and an LNA. The GNSS antenna chosen depends on the particular application. Each model offers exceptional phase center stability and a significant measure of immunity against multipath interference. Each antenna has an environmentally sealed radome and all meet the European Union's Restriction of Hazardous Substances (RoHS) and Waste Electrical and Electronic Equipment (WEEE).

2.3.1 Choosing a Coaxial Cable



To select a coaxial cable for the application, consult the NovAtel application note [APN-003 RF Equipment Selection and Installation](#) available at www.novatel.com/support/. Also refer to this application note if the application requires the use of cable longer than 30 m.

An appropriate coaxial cable matches the impedances of the antenna and receiver (50 ohms) and has a line loss not exceeding 10.0 dB. If the limit is exceeded, excessive signal degradation may occur and the receiver may not meet performance specifications. NovAtel offers several coaxial cables to meet GNSS antenna interconnection requirements, including:

- 5, 15 and 30 m antenna cable with TNC connectors on both ends (NovAtel part numbers GPS-C006, GPS-C016 and GPS-C032)



A conversion is required between the OEM617D, OEM628 and OEM638's MMCX connector or the OEM615's and OEM617 MCX connector and the female TNC connector on NovAtel's GNSS antennas.



NovAtel recommends using high quality coaxial cables because an impedance mismatch is possible when using lower quality cables and this produces reflections in the cable that increases signal loss. Although other high quality antenna cables can be used, the performance specifications of the OEM6 family receivers are warranted only when used with NovAtel supplied accessories.

2.3.2 Mounting the GNSS Antenna

After the OEM6 family card is installed in an enclosure, the antenna can be mounted and connected. The GNSS receiver is designed to operate with any of the NovAtel single, dual and triple-frequency GNSS antenna models. See *Section 2.3, Selecting a GNSS Antenna* on page 29 for more information.

When installing the antenna:

- Choose an antenna location with a clear view of the sky so each satellite above the horizon can be tracked without obstruction. For more information on RF signal propagation and multipath, refer to the NovAtel application note [APN-008 Discussions on RF Signal Propagation and Multipath](#) at www.novatel.com/support/.
- Mount the antenna on a secure, stable structure capable of safe operation in the specific environment.

2.3.3 Connecting the Antenna to the Receiver

Connect the antenna to the receiver using a high quality coaxial cable (as discussed in *Section 2.3.1, Choosing a Coaxial Cable* on page 29).

615

For the OEM615, an interconnect adapter cable is required to convert the end of the coaxial cable to the card's MCX female RF input connector. The RF connector location for the OEM615 is shown in *Figure 10, OEM615 Connector and Indicator Locations* on page 35. A user supplied LNA_PWR supply is internally regulated to 5 VDC and sent to the center pin of the MCX RF connector to power an external antenna (the return is the outer conductor of the coax).

The antenna port is capable of providing up to 100 mA to a connected antenna (based on a 6 V input supply). Higher input voltages should follow the derating curve (refer to *Appendix A, OEM615 Technical Specifications* on page 113 for antenna details). The typical current draw for a NovAtel antenna is less than 40 mA.

617

For the OEM617, an interconnect adapter cable is required to convert the end of the coaxial cable to the card's MCX female RF input connector. The RF connector location for the OEM617 is shown in *Figure 11, OEM617 Connector and Indicator Locations* on page 36. A user supplied LNA_PWR supply is internally regulated to 5 VDC and sent to the center pin of the MCX RF connector to power an external antenna (the return is the outer conductor of the coax).

The antenna port is capable of providing up to 200 mA to a connected antenna (based on a 6 V input supply). Higher input voltages should follow the derating curve (refer to *Appendix B, OEM617 Technical Specifications* on page 125 for antenna details). The typical current draw for a NovAtel antenna is less than 40 mA.

617D

For the OEM617D, an interconnect adapter cable is required to convert the end of the coaxial cable to the card's MMCX female RF input connector. The RF connector location for the OEM617D is shown in *Figure 12, OEM617D Connectors and Indicators* on page 36. A user supplied LNA_PWR supply is internally regulated to 5 VDC and sent to the center pin of the MMCX RF connector to power an external antenna (the return is the outer conductor of the coax).

The antenna ports are capable of providing up to 100 mA to a connected antenna (based on a 6 V input supply). Higher input voltages should follow the derating curve (refer to *Appendix C, OEM617D Technical Specifications* on page 135 for antenna details). The typical current draw for a NovAtel antenna is less than 40 mA.

628

For the OEM628, an interconnect adapter cable is required to convert the end of the coaxial cable to the card's MMCX female RF input connector. The RF connector location for the OEM628 is shown in *Figure 13, OEM628 Connector and Indicator Locations* on page 37.

The OEM628 has an internal 5 V LNA_PWR supply, limited to 100 mA.

Refer to *Appendix D, OEM628 Technical Specifications* on page 145 for details.

638

For the OEM638, an interconnect adapter cable is required to convert the end of the coaxial cable to the card's MMCX female RF input connector. The RF connector location for the OEM638 is shown in *Figure 14, OEM638 Connector and Indicator Locations* on page 38.

The OEM638 has an internal 5 V LNA_PWR supply (limited to 200 mA) and an optional LNA supply that goes to the antenna with no regulation or derating.

Refer to *Appendix E, OEM638 Technical Specifications* on page 162 for details.

Refer to *Antenna LNA Power* on page 77 for antenna power requirements.

2.4 Power Supply Requirements



Power to the NovAtel receiver card must be applied for >150 ms before any of the external interfaces are powered on by the integrator's card.



Hold the RESETIN pin low during power up and for >150 ms after power is applied.

This section contains information on the requirements for the input power to the receiver. Refer to the following for complete power specifications:

- *Appendix A, OEM615 Technical Specifications* on page 113
- *Appendix B, OEM617 Technical Specifications* on page 125
- *Appendix C, OEM617D Technical Specifications* on page 135
- *Appendix D, OEM628 Technical Specifications* on page 145
- *Appendix E, OEM638 Technical Specifications* on page 162



If the voltage supplied is below the minimum specification, the receiver suspends operation. If the voltage supplied is above the maximum specification, the receiver may be permanently damaged, voiding the warranty.



OEM6 family cards contain a DC-to-DC converter, tolerant to input noise and ripple. A tightly regulated input supply is not required, as long as it falls within the given input range. The power supply used for any OEM6 family card should be capable of providing the specified power requirements stated in *Table 3, Voltage Input Requirement for OEM6 Family Cards* on page 31.

Table 3: Voltage Input Requirement for OEM6 Family Cards



OEM6 Product Line	Power Input Requirement
OEM615	+3.3 VDC ±5% with less than 100 mV ripple
OEM617 OEM617D	+3.3 VDC +5%/-3% with less than 100 mV ripple
OEM628	+3.3 VDC ±5% with less than 100 mV ripple
OEM638	+3.3 VDC +5%/-3% ^a or 4.5 V - 36 VDC ^b

- a. 3.3 VDC input on J4101 pins 93, 95, 97, 99.
- b. 4.5-36 VDC input on P4001 pin 1 and J4101 pins 94, 96, 98, 100.

Refer to *Appendix A, OEM615 Technical Specifications* on page 113, *Appendix D, OEM628 Technical Specifications* on page 145 and *Appendix E, OEM638 Technical Specifications* on page 162 for further information.

The OEM615, OEM617 and OEM617D do not feature reversed polarity protection.

Both receivers are designed to prevent internal damage when subjected to reverse polarity power.

The OEM6 family cards also provide protection during a voltage event of short duration. It is recommended that appropriate fuses or current limiting be incorporated as a safety precaution on all power lines used. Use a sufficient gauge of wire to ensure the voltage at the connector is within the OEM6 family card's requirements.

2.5 Card Installation Overview

When the appropriate equipment is selected, complete the following steps to set up and begin using the NovAtel GNSS receiver.

1. Install the OEM6 family card in an enclosure with a wiring harness (refer to *Section 2.5.1, Installing an OEM6 Family Card with Wiring Harness and Enclosure* on page 32).
2. Mount the GNSS antenna to a secure, stable structure.
3. Connect the GNSS antenna to the receiver using an antenna RF cable (refer to the information in *Section 2.3.3, Connecting the Antenna to the Receiver* on page 30).
4. Apply power to the receiver, as described in *Section 2.5.2, Applying Power to the Receiver* on page 38.
5. Connect the receiver to a computer or other data communications equipment (refer to *Section 2.5.3, Connecting Data Communications Equipment* on page 38 for instructions).

2.5.1 Installing an OEM6 Family Card with Wiring Harness and Enclosure

To install an OEM6 family card:

1. Ensure adequate ESD protection is used as described in the following section.
2. Mount the OEM6 family card in a secure enclosure to reduce environmental exposure and RF interference, as described in *Mounting the Printed Circuit Board* on page 33.
3. Prepare a wiring harness to interface with the receiver's data, status and power signals using the information in *Preparing the Data, Signal and Power Harness* on page 34.

Electrostatic Discharge (ESD) Precautions

ESD is a leading cause of failure of electronic equipment components and printed circuit boards containing ESD sensitive devices and components. Follow ESD precautions when handling or installing an OEM6 family card. See *Appendix J, Electrostatic Discharge (ESD) Practices* on page 206 for more information on ESD precautions.

When the OEM6 family card is removed from the original packing box, keep the box and ESD protection for future storage or shipment. Leave the OEM6 family card in the static shielding bag or clamshell when not connected in a normal operating environment.



- Always wear a properly grounded anti-static wrist strap when handling OEM6 cards.
- Always hold the OEM6 family card by the corners or the RF shield: avoid direct contact with any of the components.
- Never let the OEM6 family card come in contact with clothing. The ground strap cannot dissipate static charges from fabrics.
- Failure to follow accepted ESD handling practices could cause damage to the OEM6 family card.
- The warranty may be void if equipment is damaged by ESD.

Mounting the Printed Circuit Board

The OEM6 family cards are OEM products and the printed circuit board is provided without a housing structure. This allows flexibility in creating a mounting environment to suit particular product and market requirements.



When installing cards, ensure all standoffs are properly installed and the mounting location is level.

The amount of board deflection (bow and twist) must not exceed 0.75% of its characteristic dimension. For example, on the OEM615, which is 71 mm long and 46 mm wide, the deflection along the length must not exceed 0.53 mm and the deflection along the width must not exceed 0.34 mm.



The OEM6 receivers equipped a high vibration TCXO can be mounted in a number of ways. The primary method is to use isolation mounts. This has been confirmed, via testing, to be an excellent method of mounting that will ensure that the product meets the 20G random vibrate performance requirement. The recommended 6mm, outer diameter, Vibration Isolation Mount can be ordered from J.W. WINCO. Part Number, GN 351-6-8-M3-ES-55.

The mounting and enclosure should provide for the following:

- Mounting of external connectors
- Protection from hostile physical environments (rain, snow, sand, salt, water, extreme temperatures, etc)



The OEM Integrator is responsible for ensuring compliance of the final product with the regulatory bodies for those intended markets.

- Protection from ESD (see *Appendix J, Electrostatic Discharge (ESD) Practices* on page 206)

615

617

617D

For proper grounding and mechanical integrity, the OEM615, OEM617 and OEM617D are mounted with four screws when used in a custom assembly.

628

638

For proper grounding and mechanical integrity, the OEM628 and OEM638 are mounted with six screws when used in a custom assembly.

See *Appendix A, OEM615 Technical Specifications* on page 113, *Appendix B, OEM617 Technical Specifications* on page 125, *Appendix C, OEM617D Technical Specifications* on page 135, *Appendix D, OEM628 Technical Specifications* on page 145 and *Appendix E, OEM638 Technical Specifications* on page 162 for mechanical drawings of each card.

Preparing the Data, Signal and Power Harness

The wiring harness provides connections to some or all of the following:

- Communication ports, including COM, Ethernet, USB and CAN (a CAN transceiver is required on the OEM615, OEM617, OEM617D and OEM628 cards)

638

The wiring harness for on OEM638 receiver should always provide access to the COM2 port. Access to COM2 is required for firmware updates that include FPGA updates.

638

CAN transceivers are integrated on the OEM638 card.

- Antenna/LNA power

615

617

617D

An external LNA power supply is required for the OEM615, OEM617 and OEM617D cards.

638

An external LNA power supply is optional for the OEM638.

- Input and output timing strobes
- Power input
- Optional external frequency reference

For all OEM6 family cards, the power, status and data inputs and outputs are accessed from one or more connectors. The harness therefore, must be designed to mate with this connector(s).

615

617

The OEM615 and OEM617 both use a single 20-pin header and a MCX RF input. OEM615 pin-out information is in *Appendix A, OEM615 Technical Specifications* on page 113; the OEM617 pin-out information is in *Appendix B, OEM617 Technical Specifications* on page 125.

617D

The OEM617D uses a single 20-pin header and has a Primary and Secondary MMCX RF input. OEM617D pin-out information is in *Appendix C, OEM617D Technical Specifications* on page 135.

628

As shown in *Figure 13, OEM628 Connector and Indicator Locations* on page 37 the OEM628 card uses 24-pin and a 16-pin headers for the data, power and status signals: The RF input is an MMCX female connector. An external oscillator input is available, also through an MMCX female connector.

The pin-outs for all connectors and manufacturers' part numbers are specified in *Appendix D, OEM628 Technical Specifications* on page 145.

638 As shown in *Figure 15, COM3 and USB Multiplexed on OEM615, OEM617 and OEM617D* on page 40, the OEM638 card uses 10-pin, 40-pin and 100-pin headers. The RF input is an MMCX female connector. An external oscillator input is available, also through an MMCX female connector.

The pin-outs for all connectors and manufacturers' part numbers are specified in *Appendix E, OEM638 Technical Specifications* on page 162.

NovAtel recommends biasing unused inputs to their default states.

Figure 10: OEM615 Connector and Indicator Locations

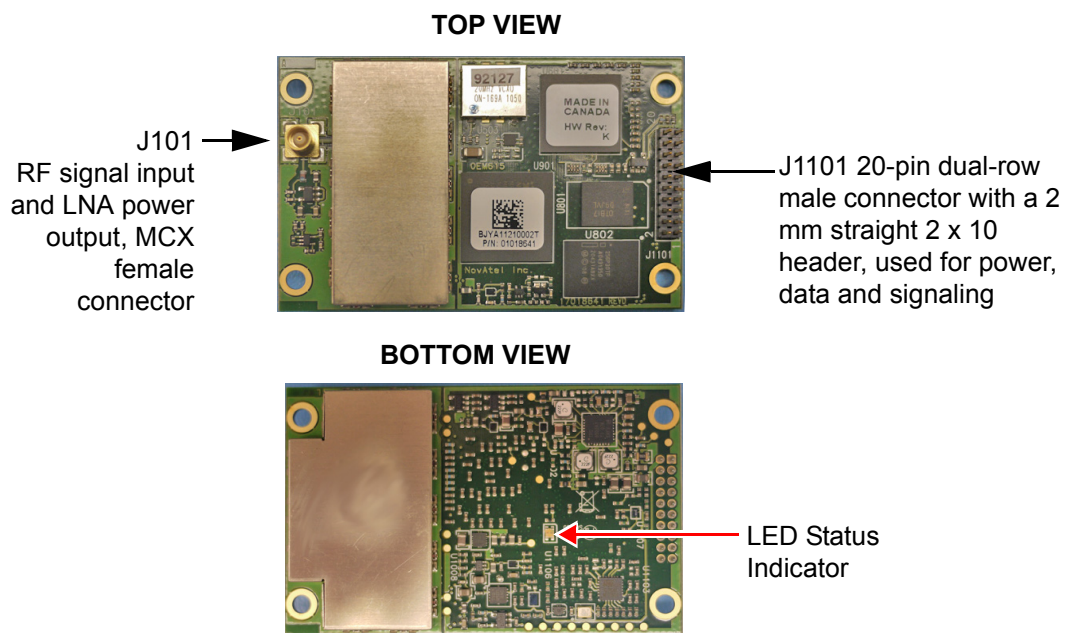

Figure 11: OEM617 Connector and Indicator Locations

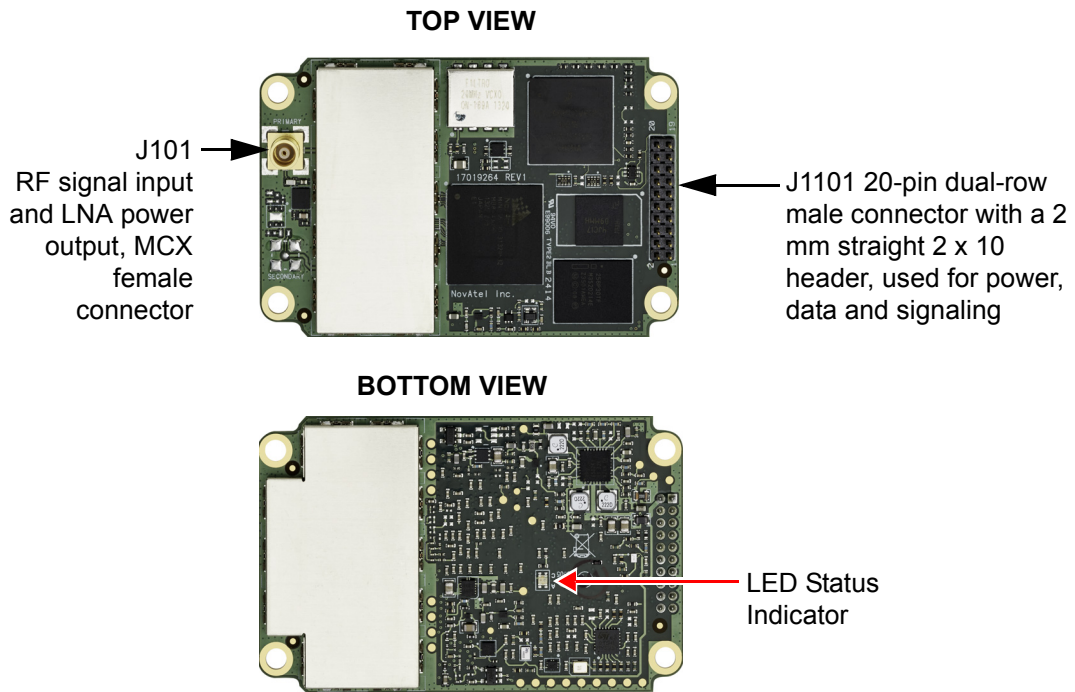

Figure 12: OEM617D Connectors and Indicators

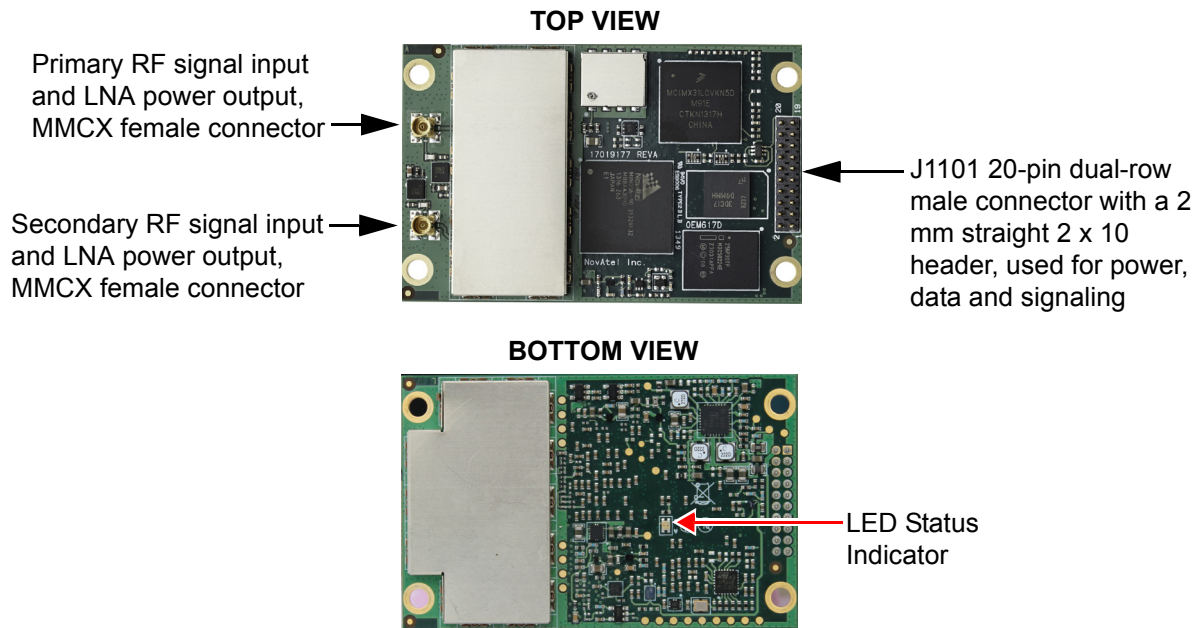

Figure 13: OEM628 Connector and Indicator Locations

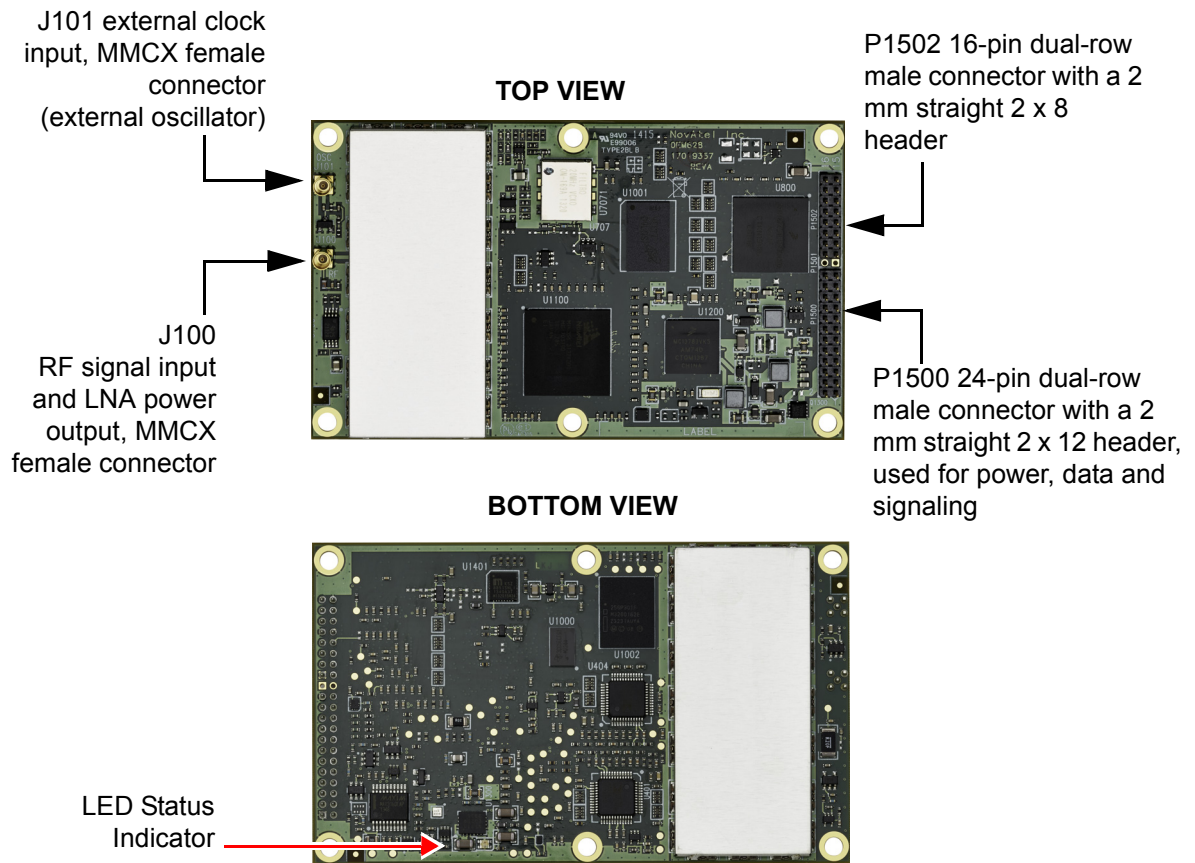
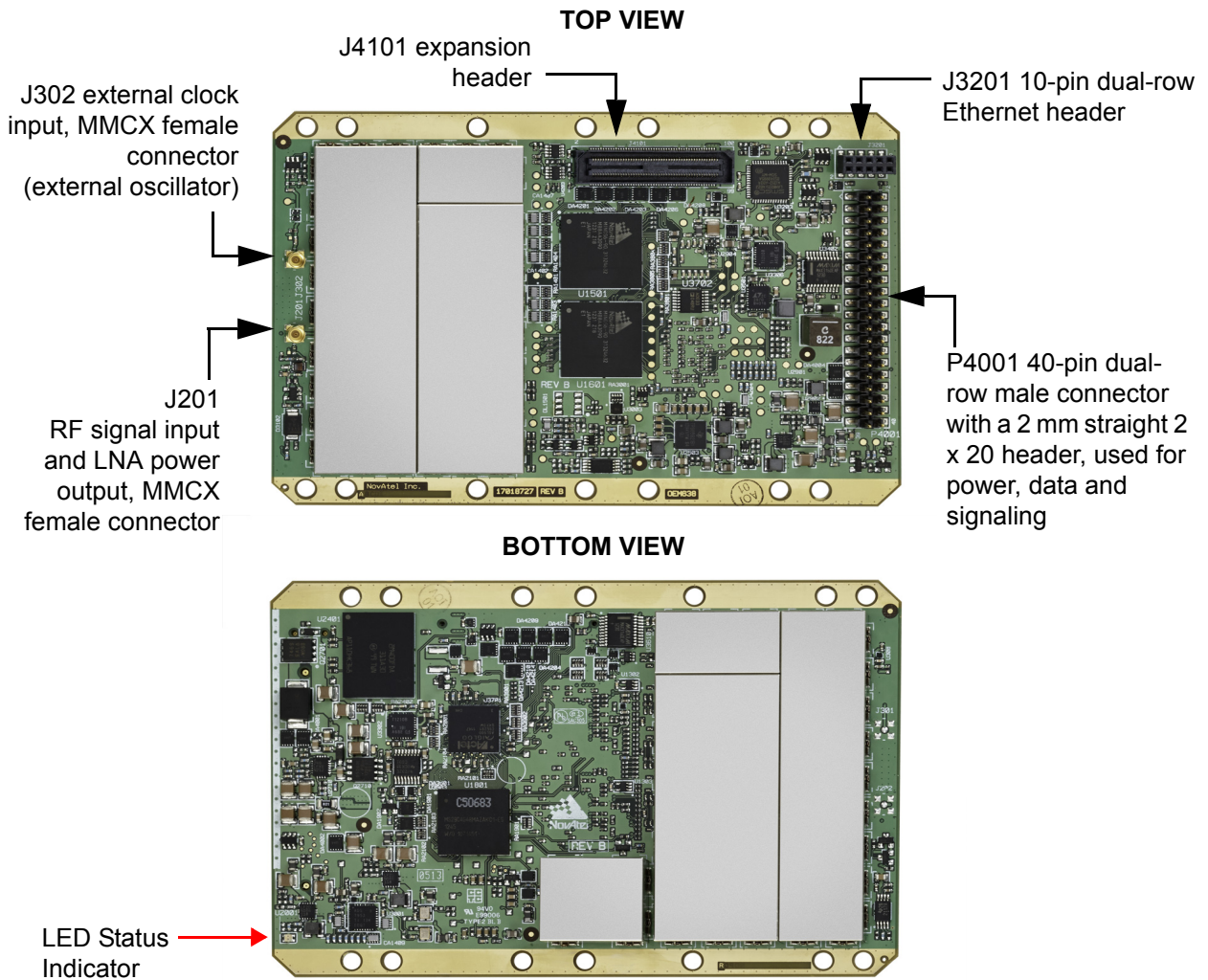

Figure 14: OEM638 Connector and Indicator Locations



2.5.2 Applying Power to the Receiver

Set the power supply to the voltage indicated in *Table 3, Voltage Input Requirement for OEM6 Family Cards* on page 31, then connect the power supply to the wiring harness.

2.5.3 Connecting Data Communications Equipment

To send commands and obtain logs, connect the receiver to a data communications device. The default configuration for OEM6 receivers is shown in *Table 4, OEM6 Card Default Serial Port Configurations* on page 39.

On some receivers, the serial ports can be user configured for RS-232, RS-422 or LVTTTL operation. Refer to *Section 4.1.1, Serial Ports* on page 52 for instructions.

Table 4: OEM6 Card Default Serial Port Configurations

Model	COM1	COM2	COM3	COM4	COM5	IMUCOM (COM6)
615 617 617D	LVTTTL with no flow control	LVTTTL with no flow control	LVTTTL with no flow control	N/A	N/A	N/A
628	User configurable as RS-232 with flow control or RS-422 without flow control	LVTTTL with flow control	LVTTTL with no flow control	N/A	N/A	N/A
638	User configurable as RS-232 with flow control or RS-422 without flow control	User configurable as RS-232 with flow control or RS-422 without flow control	LVTTTL with flow control	LVTTTL with flow control	LVTTTL with flow control	User configurable as RS-232 with flow control or RS-422 without flow control

Refer to *Serial Ports* on page 52 for details on configuring RS-232 and RS-422 for the OEM6 family.

Each port may support some or all of the following signals:

- Request To Send (RTS) [COM1 and COM2]
- Clear To Send (CTS) [COM1 and COM2]
- Received Data (RX)
- Transmitted Data (TX)

638 All six COM ports on the OEM638 have all signals (TX/RX/RTS/CTS). In addition, COM2 has DTR/DCD flow control signals.

628 If using the Ethernet connectivity, the distance between the RJ45 connector and the magnetics must be no more than 10 inches (25.4 cm) and the distance between the device and the magnetics must be no more than 1.5 inches (3.8 cm). The OEM638 and **638** uses the Micrel KSZ8851SNLI device. Follow Micrel's recommendations for transformer selection.

Port settings (bit rate and parity, for example) are software configurable. See *Chapter 4, Operation OEM6 Cards and Enclosures* on page 51. Also see *Appendix A, OEM615 Technical Specifications* on page 113, *Appendix C, OEM617D Technical Specifications* on page 135, *Appendix D, OEM628 Technical Specifications* on page 145 and *Appendix E, OEM638 Technical Specifications* on page 162 for further information on data communications specifications and pin assignments.

OEM615, OEM617 and OEM617D Receivers

COM1, COM2 and COM3 are CMOS LVTTTL level I/O pins only. These ports require the addition of an RS-232/RS-422 transceiver to provide appropriate signal levels. Most RS-232 or RS-422 transceivers provide adequate ESD protection.

Refer to *Section A.2.1, Logic-Level I/O* on page 122 for details.

The OEM615, OEM617 and OEM617D receivers have three LVTTTL COM ports:

- COM1 RX is at pin 12 of the main header
- COM1 TX is at pin 11 of the main header
- COM2 RX is at pin 15 of the main header
- COM2 TX is at pin 14 of the main header
- COM3 TX is at pin 9 of the main header
- COM3 RX is at pin 4 of the main header

COM3 is multiplexed with USB and EVENT1. USB and EVENT1 are enabled by default.

Figure 15: COM3 and USB Multiplexed on OEM615, OEM617 and OEM617D

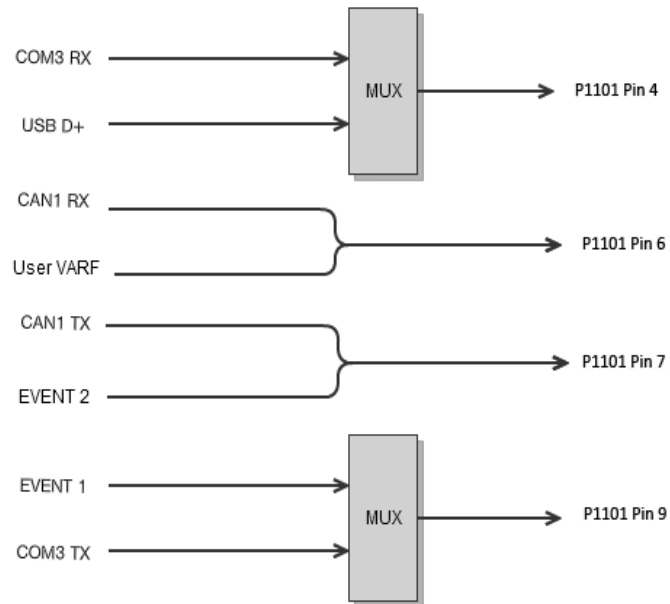

To enable COM3, issue the following commands:

1. INTERFACEMODE USB1 NONE NONE
2. INTERFACEMODE USB2 NONE NONE
3. INTERFACEMODE USB3 NONE NONE
4. MARKCONTROL MARK1 DISABLE
5. INTERFACEMODE COM3 NOVATEL NOVATEL
6. SAVECONFIG (optional)

To enable USB, issue the following commands:

1. INTERFACEMODE COM3 NONE NONE
2. INTERFACEMODE USB1 NOVATEL NOVATEL
3. INTERFACEMODE USB2 NOVATEL NOVATEL
4. INTERFACEMODE USB3 NOVATEL NOVATEL
5. SAVECONFIG (optional)

To enable EVENT1, issue the following commands:

1. INTERFACEMODE COM3 NONE NONE
2. MARKCONTROL MARK1 ENABLE
3. SAVECONFIG (optional)

OEM628 Receiver

The OEM628 card, COM1 can be configured as either RS-232 (with hardware flow control, if the cable used supports it) or RS-422 (with no hardware flow control), by setting main connector pin 2 LOW or HIGH respectively.



By default, RS-232 is selected since the pin-2 input, if open, is pulled LOW by an internal pull down resistor.

To select RS-422, apply 3.3 VDC to pin 2 during start-up. See *Figure 78, Top-view, P1500 Main Connector 24-Pin Header* on page 154 for pin-out details for COM1 RS-232 and RS-422 configurations.

A third serial port, COM3, is also available on pin 7 (RXD) and pin 19 (TXD). By default, COM3 is enabled. COM3 is multiplexed with both EVENT2 and USER0.

To enable COM3:

1. If a user application is running, make sure it does not initialize GPIO_USER0.
2. Issue the following command: MARKCONTROL MARK2 DISABLE
3. Issue the following command: INTERFACEMODE COM3 NOVATEL NOVATEL ON
Use any interface mode except NONE

Refer to the OEM6 Family Firmware Reference Manual (OM-20000129) for further command information.

To enable MARK2:

Issue the following command:

1. MARKCONTROL MARK2 ENABLE
2. INTERFACEMODE COM3 NONE NONE OFF

Figure 16: OEM628 COM3 Multiplexed with EVENT2 and USERGPIO

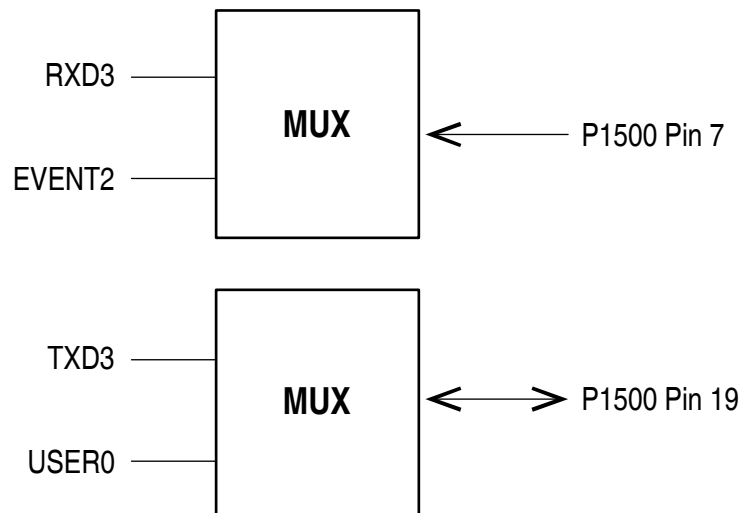

OEM638 Receiver

The OEM638 card, COM1 can be configured as either RS-232 (with hardware control if the cable used supports it) or RS-422 (with no hardware flow control), by setting the main connector pin-30 LOW or HIGH respectively. The default is RS-232. The `SERIALPROTOCOL` command can be used to override the protocol selected at boot time or choose between RS-232 (default) and RS-422.

 None of the COM port pins are multiplexed with other I/O functions. All COM port pins have a dedicated function.

Figure 17: OEM638 Multiplexed Pin Options



Refer to the [OEM6 Family Firmware Reference Manual](#) (OM-20000129) for further command information.

2.6 OEM638 Card Security **638**

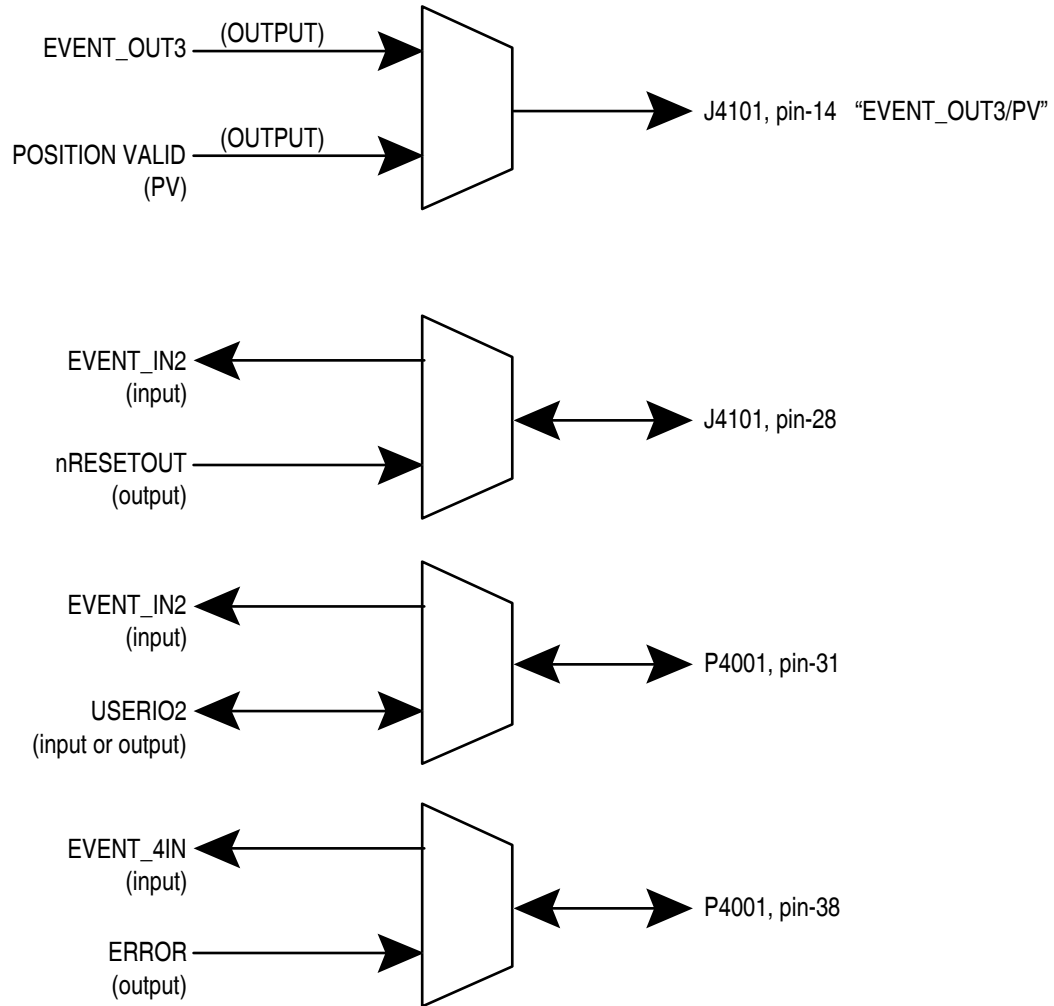
2.6.1 Administration Password

An Administrator password is available to secure FTP and ICOM ports. The default Administrator password is the PSN of the receiver board and the predefined user name is “admin”.

An Administrator has read/write access and the ability to change passwords, issue commands, upload files to the FTP server or upload new firmware.

A password can be up to a maximum of 28 characters/digits. The “admin” user name cannot be changed. Use the `SETADMINPASSWORD` command to change the default password.

Refer to the [OEM6 Firmware Reference Manual](#) (OM-20000129) for command details.

2.6.2 FTP Server and ICOM Port



The Administrator password should be changed prior to using the FTP server or ICOM ports.

The FTP server is disabled by default. The `IPSERVICE FTP_SERVER` command is issued to enable or disable the FTP server port.

For security purposes, the `IPSERVICE SECURE_ICOM` command can also be used to enable password security on the ICOM ports. When security is enabled, the port refuses incoming commands until a valid User Name and Password are entered using the `LOGIN` command. Once logged in to an ICOM port, use the `LOGOUT` command to sign out of the connection and re-secure the port.

Refer to the [OEM6 Firmware Reference Manual](#) - OM-20000129 for command details.

2.7 Installing NovAtel PC Utilities



Download the latest NovAtel Connect PC Utilities suite of software and documentation, including NovAtel Connect™ from the PC Software section of www.novatel.com/support/search/. The utilities include tools for accessing and manipulating data from the OEM6 receivers.

This chapter provides instructions and guidelines for checking the contents of the shipping box, installing the NovAtel PC utilities on a computer and installing a NovAtel enclosure.



The FlexPak6 contains NovAtel's OEM628 receiver card; the FlexPak6D contains NovAtel's OEM617D receiver card.

3.1 Shipping Box

The following is provided with the FlexPak6:

- 1 12 V power adapter cable
- 1 null modem serial cable
- 1 USB cable ((**FPk6**) only)
- 1 I/O cable
- 2 SMA to TNC adapter cables ((**FPk6D**) only)
- Quick Reference Guide

Complete the following steps to connect and power your FlexPak6 or FlexPak6D.

3.2 Additional Equipment Required

For the receiver to perform optimally, the following additional equipment is required:

- GNSS antenna (for a list of NovAtel GNSS antennas, see NovAtel's active GNSS antennas provide precise phase centers and robust enclosures refer to our web site www.novatel.com/antennas)
- Power supply



When the OEM6 family receiver is installed in a permanent location, it should be protected by a lightning protection device according to local building codes (refer to the *Lightning Protection Installation and Grounding Procedure* on page 15).

3.3 Selecting a GNSS Antenna

An active antenna with an LNA is required to boost the power of the incoming signal to compensate for the line loss between the antenna and the receiver.

NovAtel offers a variety of antennas, including single and dual-frequency, triple-band and wide-band reference GNSS antennas (refer to our web site: www.novatel.com/antennas for details of available antennas). All antennas include band pass filtering and an LNA. The GNSS antenna chosen depends on the particular application. Each model offers exceptional phase center stability and a significant measure of immunity against multipath interference. Each antenna has an environmentally sealed radome and all meet the European Union's Restriction of Hazardous Substances (RoHS) and Waste Electrical and Electronic Equipment (WEEE).

3.3.1 Choosing a Coaxial Cable



To select a coaxial cable for the application, consult the NovAtel application note [APN-003 RF Equipment Selection and Installation](#) available at www.novatel.com/support/. Also refer to this application note if the application requires the use of cable longer than 30 m.

An appropriate coaxial cable matches the impedances of the antenna and receiver (50 ohms) and has a line loss not exceeding 10.0 dB. If the limit is exceeded, excessive signal degradation may occur and the receiver may not meet performance specifications. NovAtel offers several coaxial cables to meet GNSS antenna interconnection requirements, including:

- 5, 15 and 30 m antenna cable with TNC connectors on both ends (NovAtel part numbers GPS-C006, GPS-C016 and GPS-C032)



NovAtel recommends using high quality coaxial cables because an impedance mismatch, possible with lower quality cables, produces reflections in the cable that increases signal loss. Although other high quality antenna cables can be used, the performance specifications of the OEM6 family receivers are warranted only when used with NovAtel supplied accessories.

3.3.2 Mounting the GNSS Antenna

The GNSS receiver is designed to operate with any of the NovAtel single, dual and triple-frequency GNSS antenna models. See *Section 3.3, Selecting a GNSS Antenna* on page 44 for more information.

When installing the antenna:

- Choose an antenna location with a clear view of the sky so each satellite above the horizon can be tracked without obstruction. For more information on RF signal propagation and multipath, refer to the NovAtel application note [APN-008 Discussions on RF Signal Propagation and Multipath](#) at www.novatel.com/support/.
- Mount the antenna on a secure, stable structure capable of safe operation in the specific environment.

Figure 18: FlexPak6 Installation

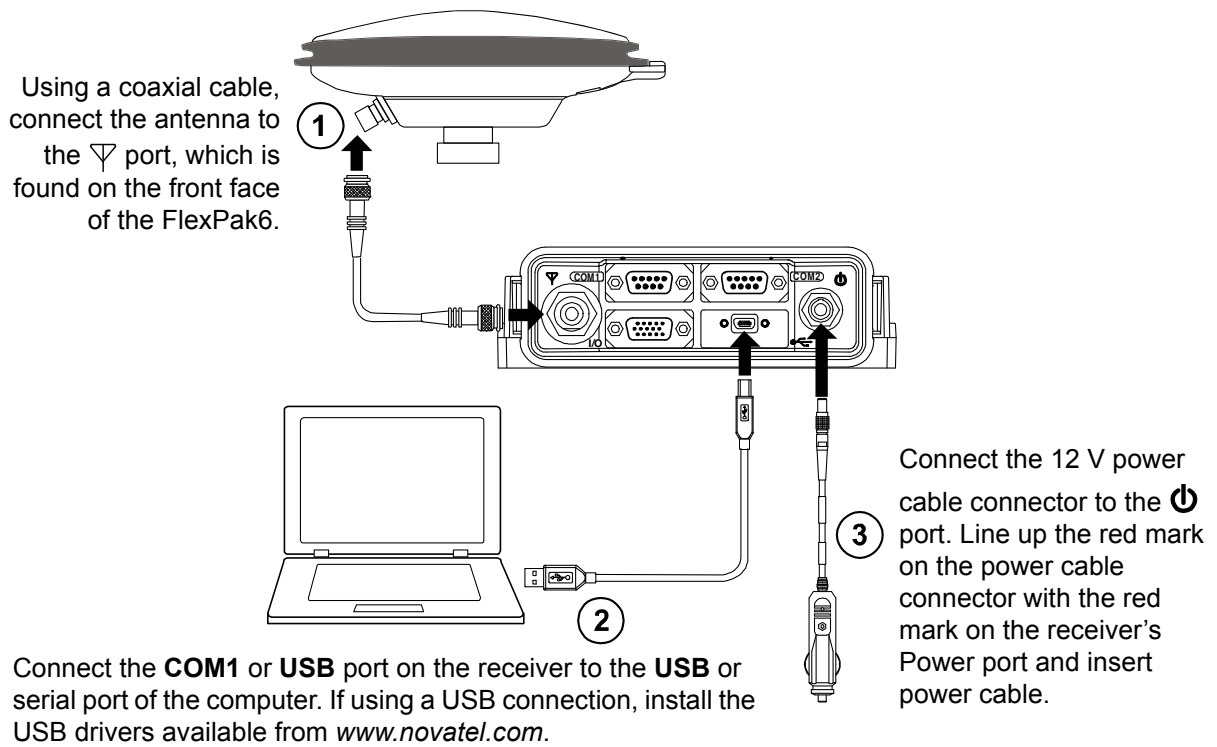
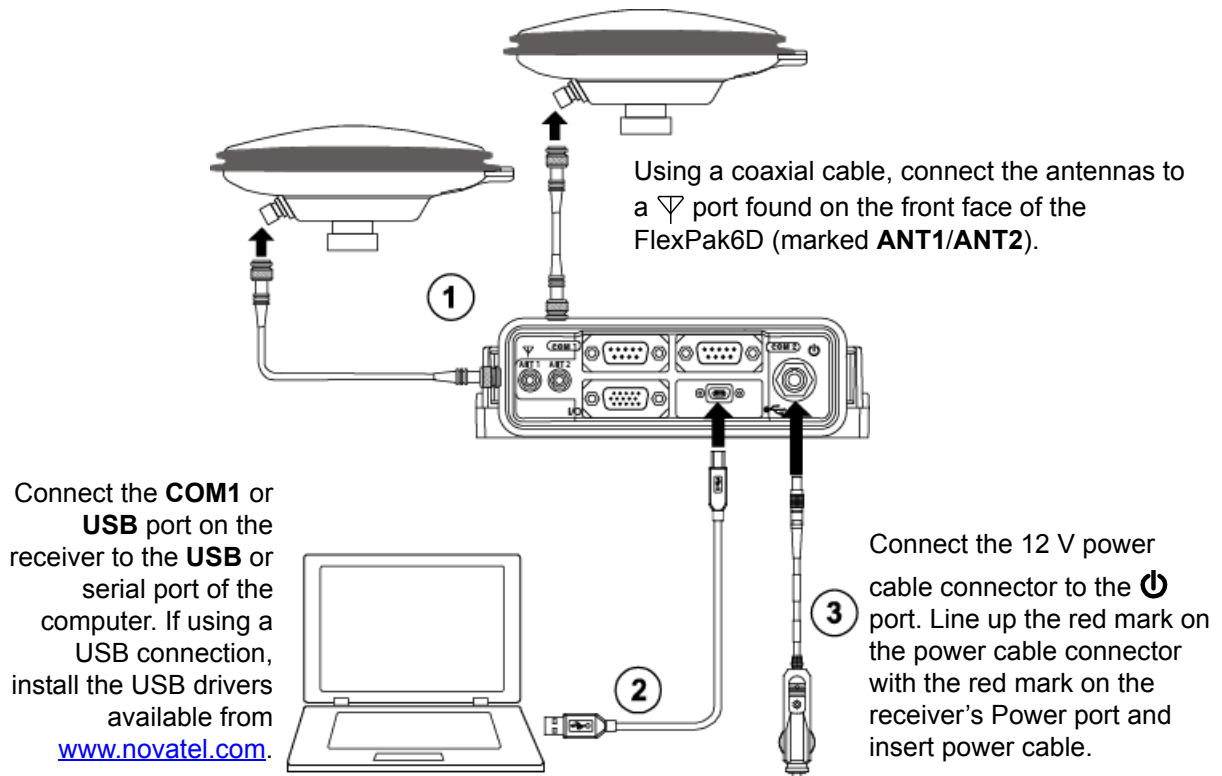

Figure 19: FlexPak6D Installation





The FlexPak6 is RS-232/RS-422 selectable through pin 9 of the I/O port, see *Table 47, FlexPak6 I/O Port Pin-Out Descriptions* on page 192 for details.



The FlexPak6D is RS-232/RS-422 selectable through pin 9 of the I/O port, see *Table 50, FlexPak6D I/O Port Pin-Out Descriptions* on page 196 for details.

Refer to *Appendix H, Enclosure Cables Technical Specifications* on page 198 for cabling details:

- *Figure 99, I/O Breakout Cable* on page 198
- *Figure 100, I/O DB-HD15 Strobe Port Cable* on page 199
- *Figure 101, Straight Through Serial Cable* on page 200
- *Figure 102, Null Modem Cable* on page 201
- *Figure 103, 12 V Power Accessory Cable* on page 202
- *Figure 104, FlexPak6D SMA to TNC Adapter Cable* on page 203



The FlexPak6 and FlexPak6D enclosures are Data Terminal Equipment (DTE) so that TXD and RTS are outputs while RXD and CTS are inputs. A null modem cable, supplied with the receiver, is required to connect to another DTE like a terminal or a computer, while a straight through cable is used to connect to another receiver.

3.3.3 FlexPak6 and FlexPak6D Alternative Power Source



The following can be used for either the FlexPak6 or FlexPak6D products.

If the 12 V car adapter is not convenient, it can be cut off from the power cable. The exposed wires can then be tied to a 6-36 VDC power supply capable of at least 5 W.



The supplied 12 V power adapter cannot be used for 24 V or above systems.

For an alternative power source:

- a. Cut the 12 V car adapter from the power cable.
- b. Install a user supplied 6 A slow blow fuse at the power source to protect the power supply wiring and your warranty.
- c. Tie the exposed wires to a 6-36 VDC supply capable of at least 5 W. Be sure to connect the red and orange or green wires to the positive side of the power supply and connect the black and brown or white wires to the negative side of the power supply.



Since the 12 V car adapter on the supplied adapter cable incorporates a 6 A fuse, a user supplied 6 A slow blow fuse in a suitable holder must be used at the alternate power source to protect both the power supply and your warranty. The car adapter is not recommended for use if your power source is greater than 12 V.

Plug in the adapter and/or turn on the power supply. The power LED turns on when the enclosure is properly powered.

 The FlexPak6 and FlexPak6D provide an output voltage on pin 4 of COM2 (POUT). This output voltage is at the same level as the power source used to power the FlexPak6. To ensure equipment connected to COM2 is not damaged, refer to:

FlexPak6 - Table 46, FlexPak6 Port Pin-Out Descriptions on page 191 and Table 47, FlexPak6 I/O Port Pin-Out Descriptions on page 192.

FlexPak6D - Table 49, FlexPak6D Port Pin-Out Descriptions on page 195 and Table 50, FlexPak6D I/O Port Pin-Out Descriptions on page 196.

 The FlexPak6 Ethernet ports are Safety Extra-Low Voltage (SELV) circuits only and are suitable for connection within a building only. Do not connect them to Telephone Network Voltage (TNV) circuits.



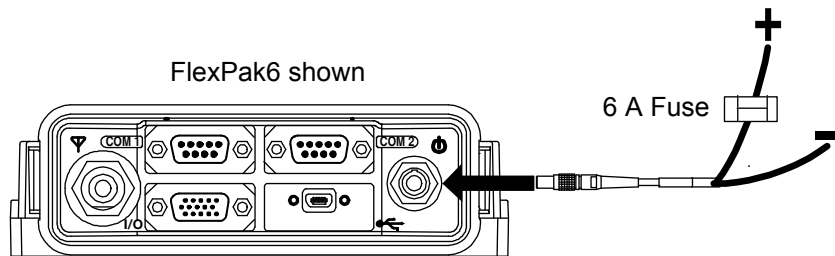



Table 5: Fuse/Holder Recommendations-12 V System

Fuse	Holder
BK/MDA-6-R Fuse (or equivalent)	BK/HFA-R-R Fuse (or equivalent)
BK/MDL-6-R Fuse (or equivalent)	

 The fuse and holder are made by Cooper/Bussmann; available from Digikey.

3.3.4 Battery Backup

If installed in a vehicle so as to avoid loss of lock when tracking L-Band, it is recommended a back-up battery be placed between the receiver and its voltage supply as a power buffer. When a vehicle engine is started, power can dip to 9.6 V DC or cut-out to ancillary equipment causing the receiver to lose lock and calibration settings.

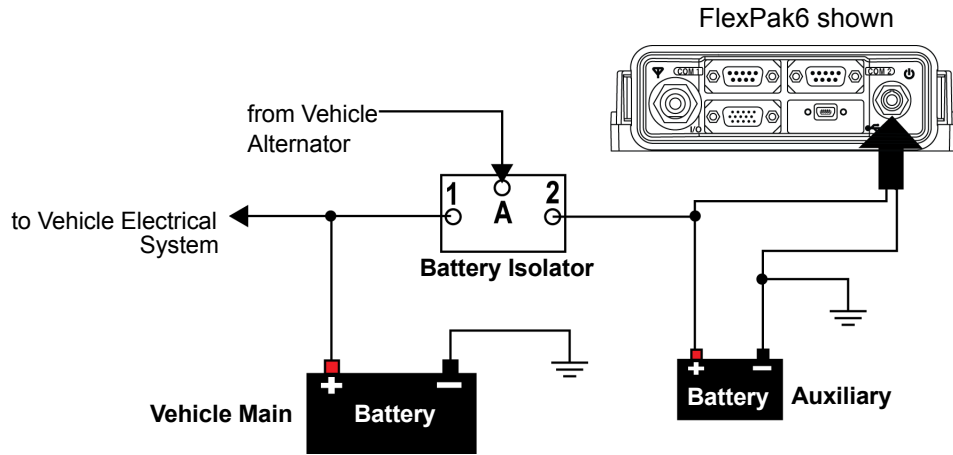

3.3.5 FlexPak6 Status Indicators and Connector Labels

The following figure indicates the connector locations and the table identifies and defines the connectors.

Figure 20: FlexPak6 Connectors

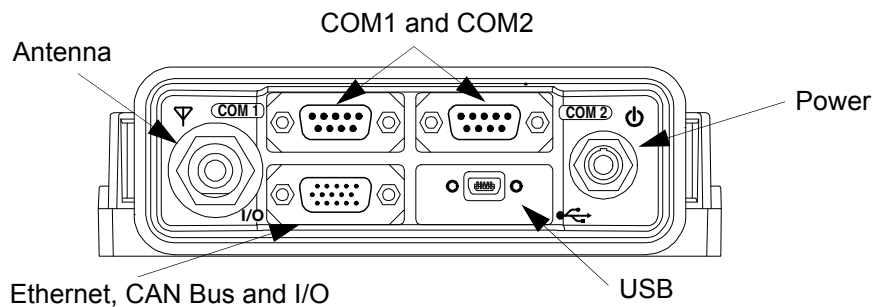

Table 6: FlexPak6 Status Indicators and Connector Labels

Connector	Description
∇ Antenna/ Position Valid	Solid <i>GREEN</i> with valid position Solid <i>RED</i> indicates a board error
COM1	Flashing <i>GREEN</i> when transmitting data from COM1 Flashing <i>RED</i> when receiving data on COM1
COM2	Flashing <i>GREEN</i> when transmitting data from COM2 Flashing <i>RED</i> when receiving data on COM2
⏻ Power	Solid <i>RED</i> when voltage within the acceptable range is applied
I/O	Input and output port for additional signals such as Ethernet and CAN Bus signals
🔌 USB	USB Communications port

3.3.6 FlexPak6D Status Indicators and Connector Labels

The following figure indicates the connector locations and the table identifies and defines the connectors.

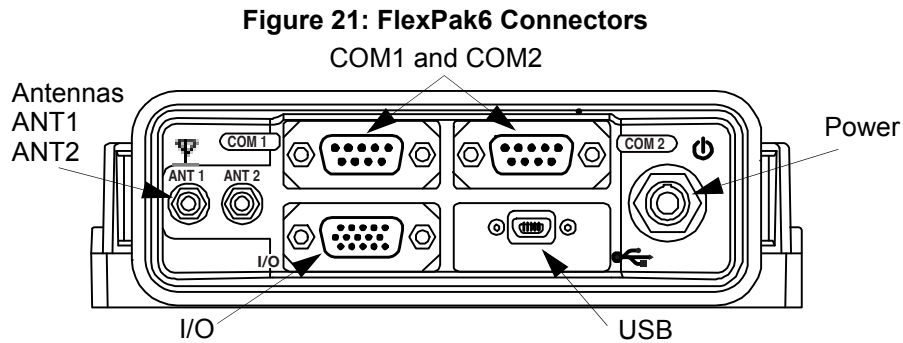

Table 7: FlexPak6D Status Indicators and Connector Labels

Connector	Description
Antenna/ Position Valid	Solid <i>GREEN</i> with valid position Solid <i>RED</i> indicates a board error
COM1	Flashing <i>GREEN</i> when transmitting data from COM1 Flashing <i>RED</i> when receiving data on COM1
COM2	Flashing <i>GREEN</i> when transmitting data from COM2 Flashing <i>RED</i> when receiving data on COM2
Power	Solid <i>RED</i> when voltage within the acceptable range is applied
I/O	Input and output port for additional signals such as PPS, Event 1 and 3, VARF, ERROR or Position Valid
	USB Communications port

Table 8: FlexPak6 and FlexPak6D Default Serial Port Configuration

Model	COM1	COM2	COM3
FlexPak6	RS-232/RS-422 ^a	RS-232/RS-422 ^b	Not available
FlexPak6D	RS-232	RS-232/RS-422 ^b	Not available

- a. Mode selected via software commands.
- b. Selected via MODE pin on the I/O connector.

3.4 Installing NovAtel PC Utilities

The NovAtel PC Utilities application contains complete instructions for the installation and use of the NovAtel PC utilities.



Download the latest PC Utilities software including NovAtel Connect™ along with the necessary user documentation from the PC Software section of www.novatel.com/support/search/.

Before operating the receiver for the first time, read the installation instructions in *Chapter 2, Installation OEM6 Family Cards* on page 28 or *Chapter 3, Installation FlexPak6 & FlexPak6D Enclosures* on page 44. The following instructions are based on a configuration similar to *Figure 22, Basic OEM6 Family Card Connection Interfaces (example)*.

Figure 22: Basic OEM6 Family Card Connection Interfaces (example)

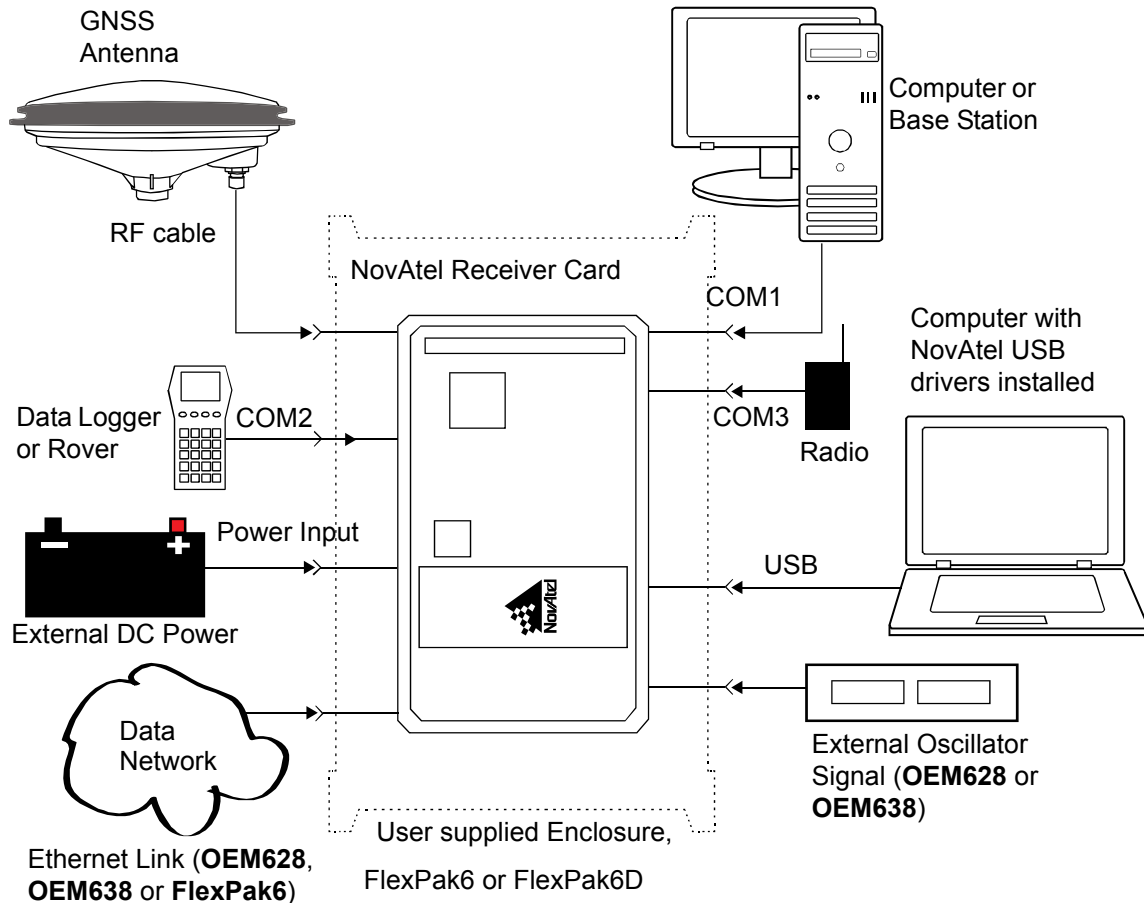

Note the figure above does not show all necessary hardware. Also see *Figure 23, Basic Differential Setup* on page 56 for a base/rover example.

COM3 is LVTTTL and signal conversion may be required depending on the equipment connected.

4.1 Communications with the Receiver

Communication is established with the receiver using a data terminal or computer connected to one of the receiver's serial ports using a null modem, USB or Ethernet cable.

When connected to the receiver, enter commands directly from the terminal or through terminal emulation software (such as NovAtel Connect or HyperTerminal) on a computer.

To maximize the application of the receiver's capabilities, become familiar with the commands and logs described in the [OEM6 Family Firmware Reference Manual](#) (OM-20000129).

4.1.1 Serial Ports

The receiver communicates with a computer or terminal via a serial port. For communication to occur, both the receiver and the operator interface have to be configured properly. The receiver’s default port settings are as follows:

- 9600 bps, no parity, 8 data bits, 1 stop bit, no handshaking, echo off

The data transfer rate determines how fast information is transmitted. Take for example a log whose message byte count is 96. The default port settings allows 10 bits/byte (8 data bits + 1 stop bit + 1 framing bit). It therefore takes 960 bits per message. To get 10 messages per second then requires 9600 bps. Also remember that even if you set the bps to 9600, the actual data transfer rate may be lower and depends on the number of satellites being tracked, data filters in use, and idle time. It is therefore suggested that you leave yourself a margin when choosing a data rate.



The minimum suggested baud rate for most applications is at least 115200 for GNSS only or 230400 for GNSS+INS. If the buffer overrun flag is present in the RXSTATUS log (refer to the [OEM6 Family Firmware Reference Manual](#) (OM-20000129)), log at a higher baud rate if possible, or change to a medium supporting higher bandwidth (USB or Ethernet).



Although the receiver can operate at data transfer rates as low as 300 bps, this is not desirable. For example, if several data logs are active (that is, a significant amount of information needs to be transmitted every second) but the bit rate is set too low, data overflows the serial port buffers, causing an error condition in the receiver status that results in lost data.

Use the SERIALCONFIG command to change settings as required for all OEM6 family receivers.

638

Refer to *Configure COM 1, 2 and IMUCOM* on page 53 for OEM638.



Refer to *Section 2.5.3, Connecting Data Communications Equipment* on page 38 for additional default setting details.

The following ports are supported and can be configured using the commands listed. Refer to the commands listed in the [OEM6 Family Firmware Reference Manual](#) (OM-20000129) for detailed instructions.

Table 9: Serial Ports Supported

Receiver Type	Port Supported	Configuration Command
OEM615 OEM617 OEM617D	COM1, COM2, COM3	SERIALCONFIG
OEM628	COM1, COM2, COM3	SERIALCONFIG and SERIALPROTOCOL
OEM638	COM1, COM2, COM3, COM4, COM5, COM6 (COM1, COM2 and COM6 are configurable RS-422/RS-232)	SERIALCONFIG and SERIALPROTOCOL
FlexPak6 FlexPak6D	COM1, COM2	SERIALCONFIG and SERIALPROTOCOL

Configure COM 1, 2 and IMUCOM **638**

COM1, COM2 and the IMUCOM ports can communicate using the RS-422 protocol in addition to the standard RS-232 protocol. On the OEM638, the IMUCOM port is equivalent to COM6.

There are 3 ways to select between RS-232 and RS-422 protocol for the various ports (default is RS-232).

1. When the receiver is powered on or reset, the user input pin USERIO1 is sampled to determine operation of COM1. If USERIO1 is low, COM1 operates in RS-232. If USERIO1 is high, COM1 operates in RS-422. Only COM1 can be selected in this manner.



If RS-232 operation is required, USERIO1 should be left floating or pulled low (GND) with a 4.7 kohm resistor. If RS-422 operation is required, USERIO1 should be pulled high (3.3 V) with a 4.7 kohm resistor. USERIO1 can be configured as an input or an output by an application. To avoid possible damage, never connect the USERIO1 pin directly to 3.3 V or GND.

2. A Configuration Code obtained from NovAtel Customer Support can be installed in the receiver to select the protocol for each port. This method overrides the USERIO1 selection method. The protocol for COM1, COM2 and IMUCOM can be independently selected.
3. The `SERIALPROTOCOL` command can be used to select RS-232 or RS-422 for any of the 3 COM ports. This method overrides the protocol set using the previous two methods.

The first two methods set the protocol mode at boot time so there is virtually no time that the communication lines are in an indeterminate or incorrect state.

For the third method, the commands are executed after the receiver has completed booting so the communication lines may be configured incorrectly during the time taken to boot and before the command can be processed. For automatic configuration, the `SERIALPROTOCOL` command can be saved using the `SAVECONFIG` command.

Refer to the [OEM6 Firmware Reference Manual](#) (OM-20000129) for command details. Refer to *Customer Support* on page 18 for contact information.

4.1.2 Communicating with a Remote Terminal

One method of communicating with the receiver is through a remote terminal. The receiver is pre-wired to allow RS-232 interface with a data terminal. To communicate with the terminal, the receiver requires only the RX, TX and GND lines be used. Handshaking is not required but is an option. Ensure the terminal's communications set up matches the receiver's RS-232 settings.

4.1.3 Communicating with a Computer

A computer can emulate a remote terminal as well as provide the added flexibility of supporting multiple command batch files and data logging storage files. Use any standard communications software package that emulates a terminal to establish bidirectional communications with the receiver. Examples include HyperTerminal or NovAtel Connect (a Graphic User Interface (GUI) program). All data is sent as raw 8-bit binary or ASCII characters.

Refer to *Section 4.2.2, Communicating with the Receiver Using NovAtel Connect* on page 54 for details.

4.2 Getting Started

The NovAtel Connect and Convert4 programs and documentation can be downloaded from the web site: <http://www.novatel.com/support/search/items/PC%20Software>. NovAtel Connect is a Windows based GUI used to access the receiver's features without special communications protocols or software. The Convert4 utility is a Microsoft Windows based utility used to convert between data formats (like ASCII to binary and NovAtel raw format to RINEX) and strip unwanted records during data file compilation.

4.2.1 Starting the Receiver

The receiver's software resides in flash memory. When first powered, it undergoes a complete self-test. If an error condition is detected during the self-test, the status word changes. This self-test status word can be viewed in the header of any data output log. Refer to the chapter on Messages in the [OEM6 Family Firmware Reference Manual](#) (OM-20000129) for header information. If a persistent error occurs, contact your local NovAtel dealer. If the dealer cannot resolve the problem, contact NovAtel Customer Support directly using one of the methods listed in *Customer Support* on page 18.



Power to the card must be applied for >150 ms before any of the external interfaces are powered on by the integrator's card.

4.2.2 Communicating with the Receiver Using NovAtel Connect



Detailed instructions for using NovAtel Connect are available from within the utility Help, the .chm file bundled with the software or from our web site www.novatel.com/support/firmware-downloads.

Open the NovAtel Connect program and select Device | Open Connection from the main menu. The Open Connection window appears. Open an existing connection or create a New connection.

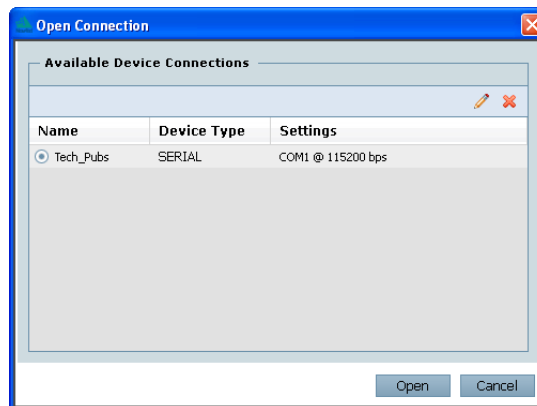

Refer to NovAtel Connect's Help (press F1, click on  icon or select the NovAtel button | Help). Ensure the Console and ASCII Messages windows are displayed (select from the View menu if necessary).

When the receiver is first turned on, no data is transmitted from the COM ports except for the port prompt. The Console window displays a port name:

[COM1] if connected to com1 port

[COM2] if connected to com2 port

or

[COM3] if connected to com3 port

Any of the COM port prompts indicate that the receiver is ready and waiting for command input. The screen may display other port names for other port types (e.g., USB1, USB2, USB3 or AUX).



1. Output from receiver self-tests may take some time. On startup, the OEM6 family receiver is set to log the RXSTATUSEVENTA log ONNEW on all ports. See *Section 5.4, RXSTATUSEVENT Log* on page 82 for more details.
2. If NovAtel Connect is unable to locate the OEM6 family receiver, use a different COM port to communicate with the receiver. When communication has been established, issue a `FRESET STANDARD` command. The original communications port should be ready for use.
3. XCOM1, XCOM2 and XCOM3 virtual ports can be generated by the receiver. However, they are unlikely to appear as a port prompt as you cannot connect to these types of ports using NovAtel Connect. Also, the XCOM ports are not available with the `SERIALCONFIG` command but may be used with other commands, such as `INTERFACEMODE` and `LOG`. Refer to the [OEM6 Family Firmware Reference Manual](#) (OM-20000129) for details on the virtual ports.

An example of a response to an input `FIX POSITION` command:

```
[COM2] FIX POSITION 51.11635 -114.0383 1048.2 [Carriage Return]
<OK
```

In this example, [COM2] is the port prompt.

This example illustrates command input to the base receiver's COM2 port that sets the position of the base station receiver for differential operation.

If the command was accepted, the receiver responds with:

```
<OK
```

If a command is entered incorrectly, the receiver responds with:

```
<ERROR:Invalid Message ID          (or a more detailed message)
```



Ensure the computer does not sleep or hibernate during a logging session or data will be lost.

4.3 Transmitting and Receiving Corrections

Corrections can be transmitted from a base station to a rover station to improve position accuracy. The base station is the GNSS receiver that acts as the stationary reference. The stationary reference has a known position and transmits correction messages to the rover station. The rover station is the GNSS receiver that does not know its exact position and requires correction messages from a base station to calculate differential GNSS positions. An example of a differential setup is shown in *Figure 23, Basic Differential Setup* on page 56.

Figure 23: Basic Differential Setup

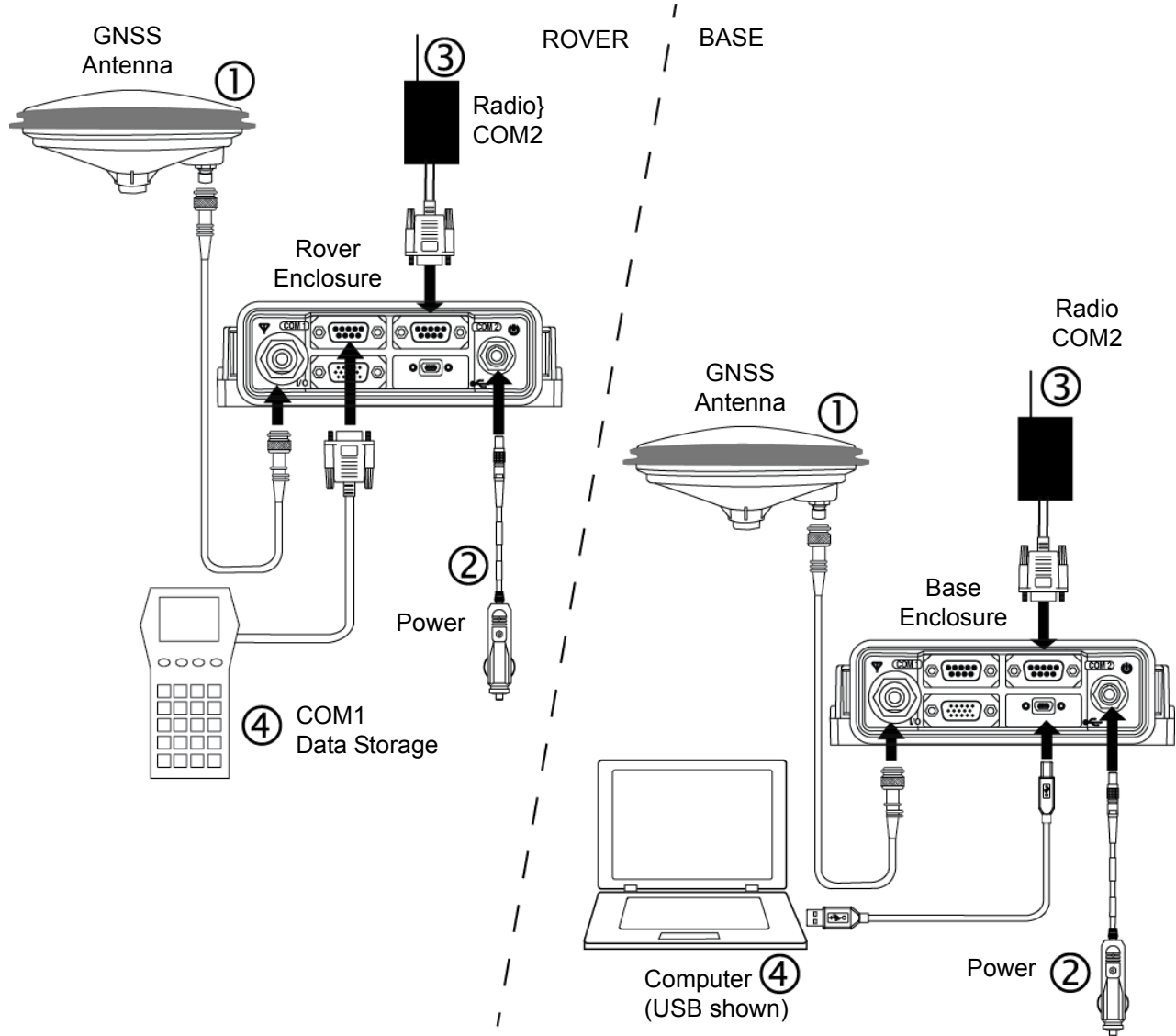

Rover Setup

- 1 Mount and connect a GNSS antenna
- 2 Connect a power supply (user supplied)
- 3 Connect a radio device to COM2 (user supplied)
- 4 Connect a storage device to COM1 (user supplied)

Base Setup

- 1 Mount and connect a GNSS antenna
- 2 Connect a power supply (user supplied)
- 3 Connect a radio device to COM2 (user supplied)
- 4 Connect a computer to COM1 for setup and monitoring (user supplied)

For information on positioning errors and the application of corrections for them, refer to the application note [APN-051 Positioning Modes of Operation](http://www.novatel.com/support/), available at www.novatel.com/support/. To receive corrections with a base/rover setup, a data link between the base station and the rover station is required. The base and rover stations can both be NovAtel receivers, however NovAtel receivers will work with some other brands. Contact Customer Support for further details (refer to *Customer Support* on page 18 for details).

The data link should support a rate of at least 19200 bits per second, but a rate of 115200 bits per second, with less than 4.0 s latency, is recommended. Unlike the base/rover concept, SBAS and L-Band corrections can be applied directly to a single receiver.

When the base and rover are set up, configure them as shown in the configuration examples in *Section 4.3.1, Base Station Configuration* on page 57 and *Section 4.3.2, Rover Station Configuration* on page 59.

4.3.1 Base Station Configuration

At the base station, enter the following commands:

```
serialconfig [port] baud [parity[ databits [stopbits [handshaking [break]]]]]
interfacemode port rx_type tx_type [responses]
fix position latitude longitude height          (enter your own lat, long and hgt values)
log port message [trigger [period]]           (port = COM2 / refer to
                                                Figure 23, Basic Differential Setup)
saveconfig                                     (optional)
```

For example:

RTK Automated Correction Generation

```
fix position lat lon hgt                      (enter your own lat, lon, hgt)
generatertkcorrections rtmcv3 com2
```

RTCA

```
serialconfig com2 9600 N 8 1 N on
interfacemode com2 none rtca off
fix position lat lon hgt                      (enter your own lat, lon, hgt)
log com2 rtcaobs2 ontime 1                   (works with both GPS and GPS + GLONASS models)
log com2 rtcaref ontime 10
log com2 rtca1 ontime 5                      (optional, enable code-DGPS coverage)
log com2 rtcaephem ontime 10 1              (optional)
saveconfig                                    (optional)
```

RTCM V2.3

```
serialconfig com2 9600 N 8 1 N on
interfacemode com2 none rtcm off
fix position lat lon hgt                      (enter your own lat, lon, hgt)
log com2 rtcm3 ontime 10
log com2 rtcm22 ontime 10 1
log com2 rtcm1819 ontime 1
log com2 rtcm1 ontime 5                      (optional)
saveconfig                                    (optional)
```

RTCM V2.3 with GLONASS

```
serialconfig com2 9600 N 8 1 N on
interfacemode com2 none rtcm off
fix position lat lon hgt                      (enter your own lat, lon, hgt)
log com2 rtcm1 ontime 5                      (optional, GPS PSRDIFF)
log com2 rtcm3 ontime 10
log com2 rtcm22 ontime 10,1
log com2 rtcm31 ontime 5,1                  (optional, GLONASS PSRDIFF)
log com2 rtcm32 ontime 10,2
log com2 rtcm1819 ontime 1
saveconfig                                    (optional)
```

RTCM V3

```

serialconfig com2 9600 N 8 1 N on
interfacemode com2 none rtcmv3 off
fix position lat lon hgt
log com2 rtcml002 ontime 1
log com2 rtcml004 ontime 1
log com2 rtcml006 ontime 10
log com2 rtcml019 ontime 120
saveconfig

```

(enter your own lat, lon, hgt)
(for L1 only models)
(for L1/L2 models)
(optional)

RTCM V3 with GLONASS

```

serialconfig com2 9600 N 8 1 N on
interfacemode com2 none rtcmv3 off
fix position lat lon hgt
log com2 rtcml002 ontime 1
log com2 rtcml004 ontime 1
log com2 rtcml010 ontime 1
log com2 rtcml012 ontime 1
log com2 rtcml006 ontime 10
log com2 rtcml033 ontime 10
log com2 rtcml019 ontime 120
log com2 rtcml020 ontime 120
saveconfig

```

(enter your own lat, lon, hgt)
(for L1 only models)
(for L1/L2 models)
(for L1 only models)
(for L1/L2 models)
(optional)

CMRPLUS (CMR+)

```

serialconfig com2 9600 N 8 1 N on
interfacemode com2 none cmr off
fix position lat lon hgt
log com2 cmrobs ontime 1
log com2 cmrglobs ontime 1
log com2 cmrplus ontime 1
saveconfig

```

(enter your own lat, lon, hgt)
(important to use ontime 1 with cmrplus)
(optional)

CMR

```

serialconfig com2 9600 N 8 1 N on
interfacemode com2 none cmr off
fix position lat lon hgt
log com2 cmrobs ontime 1
log com2 cmrglobs ontime 1
log com2 cmrref ontime 10
log com2 cmrdesc ontime 10 1
saveconfig

```

(enter your own lat, lon, hgt)
(optional)
(optional)

NOVATELX

```

serialconfig com2 9600 N 8 1 N on
interfacemode com2 none novatelx off
fix position lat lon hgt
log com2 novatelxobs ontime 1
saveconfig

```

(enter your own lat, lon, hgt)
(optional)

4.3.2 Rover Station Configuration

At the rover station, enter the following commands:

```
serialconfig [port] baud [parity[databits[stopbits[handshaking[break]]]]]
interfacemode port rx_type tx_type [responses]
```

For example, if COM2 was connected to the correction source:

RTK Automated Correction Detection

```
interfacemode com2 auto none off
```

RTCA

```
interfacemode com2 rtca none off
```

RTCAOBS2

```
interfacemode com2 rtca none off
```

RTCM V2.3

```
interfacemode com2 rtcm none off
```

RTCM V3

```
interfacemode com2 rtcmv3 none off
```

RTCM V3 with GLONASS

```
interfacemode com2 rtcmv3 none off
```

CMR+

```
interfacemode com2 cmr none off
```

CMR

```
interfacemode com2 cmr none off (same as CMR+)
```

NOVATELX

```
interfacemode com2 NOVATELX none off
```

4.3.3 ALIGN[®] Heading Master and Remote Configurations

This section provides instructions for setting up a master station with an ALIGN capable rover receiver for applications that require heading output. Refer to [APN-048 ALIGN Overview and Setup](http://www.novatel.com/support/APN-048%20ALIGN%20Overview%20and%20Setup), available at www.novatel.com/support/

Automatic Set Up for Direct-Wire Connection between Master and Rover via COM2

The ALIGNAUTOMATION command must only be sent to the rover.

```
ALIGNAUTOMATION ENABLE
```

or

```
ALIGNAUTOMATION ENABLE COM2 230400 10 ON
```

Manual Set Up via COM2

Master:

```
serialconfig com2 9600 N 8 1 N on
interfacemode com2 novatel novatelx off
movingbasestation enable
log com2 novatelxobs ontime 1
log com2 novatelxref ontime 1
log headinga onnew
log gphdt onnew
```

Rover:

```
serialconfig com2 9600 N 8 1 N on
interfacemode com2 novatelx novatel off
log com2 headingext2b onnew
log headinga onnew
log gphdt onnew
hdtoutthreshold 1.0
```

4.3.4 PDP and GLIDE™ Configurations

Pseudorange/Delta-Phase (PDP) and GLIDE position filters can be used for single-frequency single point, WAAS or DGPS positioning. Refer to the `PDPFILTER` and `PDPMODE` commands in the [OEM6 Family Firmware Reference Manual](#) (OM-20000129).

To reset the PDP or GLIDE filter:

```
pdpfilter reset
```

To enable the PDP filter:

```
pdpfilter enable
```

Ensure the `PDPFILTER` command is used before the `PDPMODE` command. Set the PDP type and kinematic type according to the application. For most kinematic applications:

```
pdpmode relative dynamic or pdpmode relative auto
```

The rest of the setup is position type and log dependent according to the application. For example, details of the `RTKSOURCE`, `PSRDIFFSOURCE`, `INTERFACEMODE`, `SERIALCONFIG` and other configuration commands are outlined in the [OEM6 Family Firmware Reference Manual](#) (OM-20000129). Also refer to the NovAtel application note [APN-038 Pseudorange/Delta-Phase \(PDP\) and GLIDE](#) available from our web site (additional Application Notes available at www.novatel.com/support/).

4.4 STEADYLINE®

The STEADYLINE functionality helps mitigate the discontinuities that often occur when a GNSS receiver changes positioning modes. The effect is especially evident when a receiver transitions from an RTK position mode solution to a lower accuracy “fall back” solution, such as NovAtel CORRECT PPP, DGPS, WAAS+GLIDE or even autonomous GLIDE (see *Figure 24, Positioning Change Without STEADYLINE* on page 61). Smooth transitions are particularly important for agricultural steering applications where sudden jumps are problematic.

Figure 24: Positioning Change Without STEADYLINE

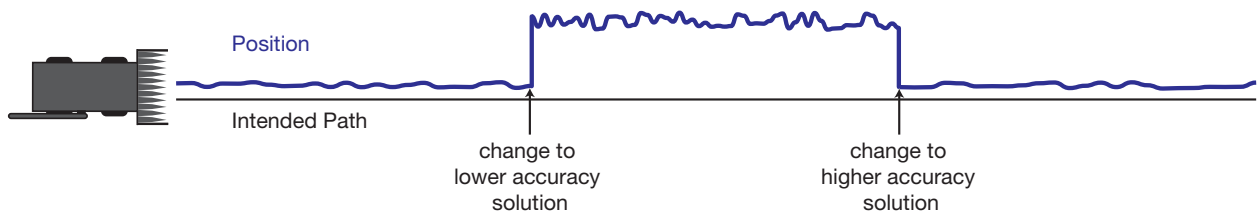

The STEADYLINE feature internally monitors the position offsets between all the positioning modes present in the receiver. When the current positioning mode becomes unavailable, the receiver transitions to the next most accurate positioning mode.

The setting in the STEADYLINE command determines how the receiver transitions to the next positioning mode. The following sections describe the STEADYLINE modes.

 For more information about the STEADYLINE command, refer to the [OEM6 Family Firmware Reference Manual](#) (OM-20000129).

4.4.1 Maintain

When the receiver transitions to a different positioning mode, it maintains the position offset calculated to limit a potential real position jump. The receiver continues to apply the position offset to all positions calculated in the new positioning mode.

Figure 25: STEADYLINE Maintain

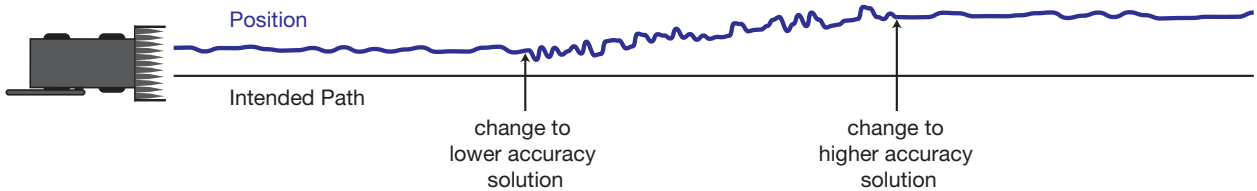

4.4.2 Transition

When the receiver transitions to a different positioning mode, the position offset is applied to the calculated position to limit a potential real position jump. The position then slowly transitions to the new reference position type over a specified period of time. This time period is specified by the Transition time parameter in the STEADYLINE command.

Figure 26: STEADYLINE Transition

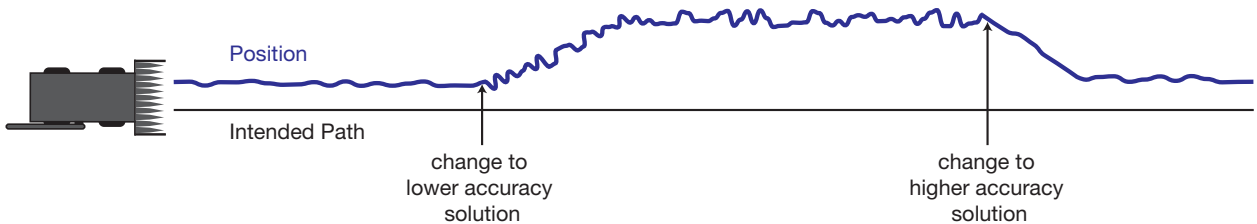

4.4.3 Prefer Accuracy

The positioning mode change depends on the accuracy level of the positioning modes.

When the position mode is changing from a more accurate mode to a less accurate mode (e.g., changing from RTK to GLIDE), the receiver uses the Maintain option.

When the position mode is changing from a less accurate mode to a more accurate mode (e.g., GLIDE to RTK), the receiver uses the Transition option.

For example, a receiver is configured to do both RTK and GLIDE. If this receiver has a fixed RTK position and experiences a loss of correction data causing the loss of the RTK solution it will immediately apply the offset between the two position modes and uses the GLIDE position stability to maintain the previous trajectory. Over time the GLIDE (or non-RTK) position will experience some drift. Once the RTK position is achieved again the receiver will start using the RTK positions for position stability and will slowly transition back to the RTK positions at a default rate of 0.005 m/s or the time specified in the `STEADYLINE` command.

Figure 27: STEADYLINE Prefer Accuracy

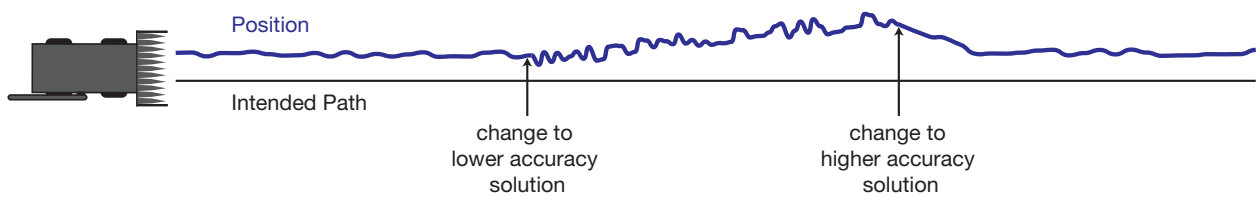

4.4.4 UAL



UAL mode will not function unless `UALCONTROL` is enabled using the `UALCONTROL` command. For more information about the `UALCONTROL` command, refer to the [OEM6 Family Firmware Reference Manual](#) (OM-20000129).

The `STEADYLINE` mode used depends on the `BESTPOS` and `GPGGA` solution types.

When the solution type is `OPERATIONAL`, the receiver uses the Maintain option.

When the solution type is `WARNING`, the receiver uses the Prefer Accuracy option. When the receiver changes from `WARNING` to `OPERATIONAL`, it will continue to use the Prefer Accuracy option until any existing offset is gone.

When the solution type is `OUT_OF_BOUNDS`, the `STEADYLINE` feature is disabled.

The thresholds used to determine the solution type (`OPERATIONAL`, `WARNING` or `OUT_OF_BOUNDS`), can be specified using the `UALCONTROL` command. Refer to the [OEM6 Family Firmware Reference Manual](#) (OM-20000129) for more information.

Figure 28, STEADYLINE UAL- Warning Limit Example on page 63 and Figure 29, STEADYLINE UAL - Out of Bounds Example on page 63 show an examples of STEADYLINE using the UAL mode.

Figure 28: STEADYLINE UAL- Warning Limit Example

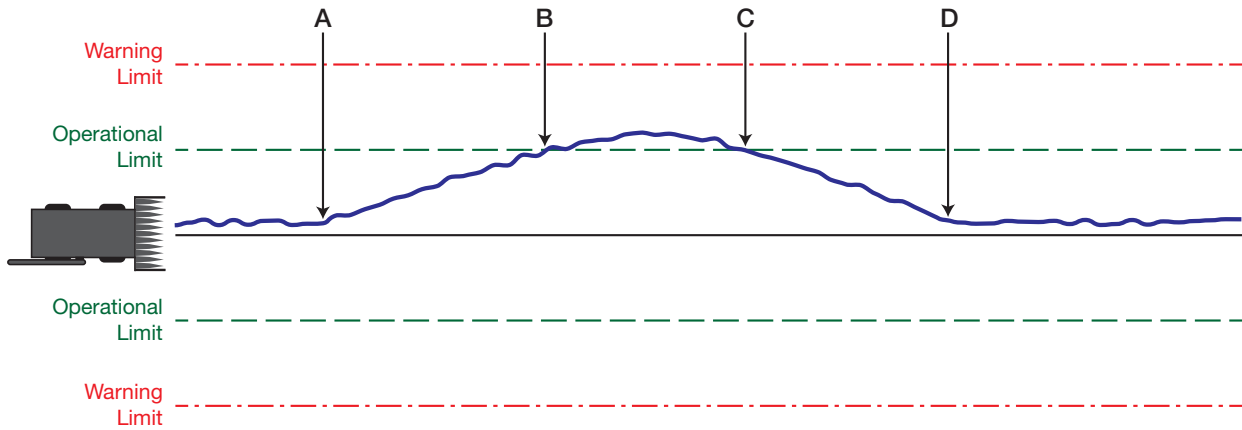

- The position type is OPERATIONAL.
- A Higher accuracy corrections are lost. The receiver changes to a lower accuracy solution. STEADYLINE operates in Maintain mode while the solution accuracy remains within the Operational limit.
 - B The solution accuracy exceeds the operational limit. The position type changes to WARNING. The STEADYLINE mode changes from Maintain to Prefer Accuracy.
 - C The solution accuracy moves back within the operational limit. The position type changes to OPERATIONAL. The STEADYLINE mode remains in Prefer Accuracy mode.
 - D The solution offset is removed. The STEADYLINE mode changes from Prefer Accuracy to Maintain.

Figure 29: STEADYLINE UAL - Out of Bounds Example

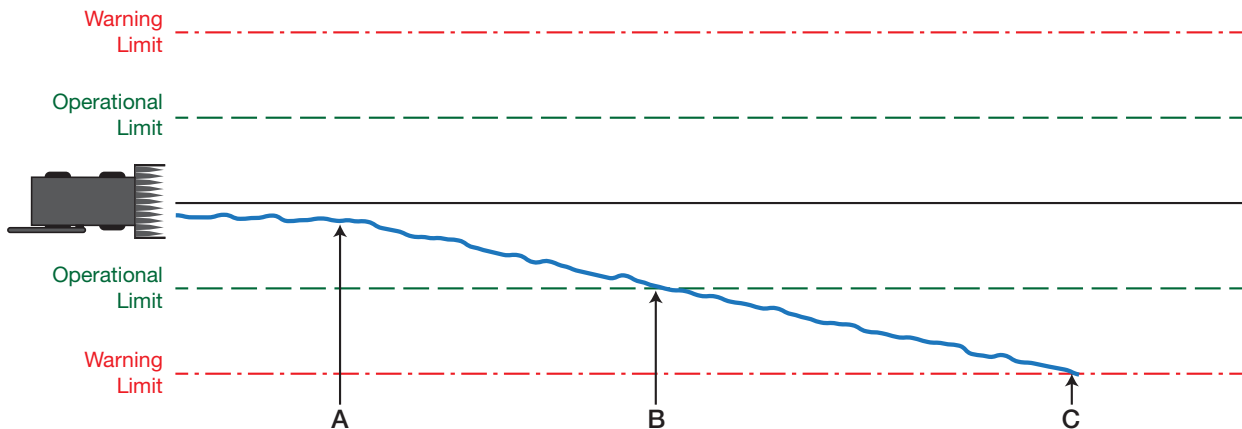

- The position type is OPERATIONAL.
- A Higher accuracy corrections are lost. The receiver changes to a lower accuracy solution. STEADYLINE operates in Maintain mode while solution accuracy remains within the Operational limit.
 - B The solution accuracy exceeds the operational limit. The position type changes to WARNING. The STEADYLINE mode changes from Maintain to Prefer Accuracy.
 - C The solution accuracy exceeds the warning limit. The position type changes to OUT_OF_BOUNDS. STEADYLINE is disabled.

4.5 Configuration Notes

For compatibility with other GNSS receivers and to minimize message size, use the standard form of RTCA, RTCM, RTCMV3, CMR+ or CMR corrections shown in the base and rover examples above. This requires using the `INTERFACEMODE` command to dedicate one direction of a serial port to one message type only. When the `INTERFACEMODE` command is used to change the mode from the NOVATEL default, the NovAtel format messages can no longer be used.

To mix NovAtel format messages and RTCA, RTCM, RTCMV3 or CMR messages on the same port, leave the interface mode set to NOVATEL and log out variants of the standard correction messages with a NovAtel header. ASCII or binary variants can be requested by appending an A or B to the standard message name. For example, on the base station:

```
interfacemode com2 novatel novatel
fix position 51.11358042 -114.04358013 1059.4105
log com2 rtcaobs2b ontime 2
```



1. Interface mode must be set to NOVATEL for the receiver to issue logs with an A or B suffix.
2. Using the receiver in NOVATEL mode consumes more CPU bandwidth than using the native differential messages as shown in *Section 4.3.1, Base Station Configuration* on page 57.
3. To find information on how to send multiple commands and log requests using DOS or Windows, search our knowledge database available at www.novatel.com/support/.

At the rover, leave the interface mode default settings (`interfacemode com2 novatel novatel`). The rover recognizes the default and uses the corrections it receives with a NovAtel header.

The `PSRDIFFSOURCE` and `RTKSOURCE` commands set the station ID values that identify the base stations to accept pseudorange or RTK corrections from. They are useful commands when the rover station is receiving corrections from multiple base stations.

4.6 Enabling SBAS Positioning

OEM6 family receivers are capable of SBAS positioning. This positioning mode is enabled using the `SBASCONTROL` command:

```
sbascontrol enable auto
```

When the command is entered, the OEM6 family card automatically tracks the SBAS that is operating in the region (e.g., WAAS or EGNOS) and applies the corrections from the service. On a simulator, leave the test mode parameter off or specify NONE explicitly. For more on SBAS, refer to application note [APN-051 Positioning Modes of Operation](#) (additional Application Notes available at www.novatel.com/support/).

4.7 Enabling L-Band

L-Band equipped receivers can achieve sub-metre position accuracy using correction data received from geostationary satellites. To use the L-Band corrections, an L-Band-capable receiver model and antenna are required (refer to our web site www.novatel.com/products/gnss-antennas for information on NovAtel L-Band-capable antennas).

For more information on L-Band positioning, refer to:

- NovAtel Application Notes: APN-061 NovAtel CORRECT with TerraStar, APN-062 NovAtel CORRECT with Veripos (service dependent) or APN-051 Positioning Modes of Operation available from www.novatel.com/support/search/items/Application%20Note
- the [OEM6 Family Firmware Reference Manual](#) (OM-20000129) for log/command details and/or
- visit www.novatel.com/support
- visit www.novatel.com/products/novatel-correct



OEM615, OEM617, OEM617D and FlexPak6D are not L-Band capable.

4.7.1 TerraStar Subscriptions

A subscription is required to use TerraStar service for land, airborne and near shore applications. Near shore applications are defined as vessels operating within 10 km of shore. To obtain a subscription, contact your local NovAtel sales representative or visit www.novatel.com/products/terrastar-gnss-corrections. The NovAtel product serial number (PSN) is needed to obtain a subscription. To obtain the receiver serial number, enter the following command:

```
log versiona once
```

To activate a subscription, the receiver must be powered and tracking an L-Band TerraStar satellite prior to the planned activation time. Use the `ASSIGNLBANDBEAM` command to configure the receiver to track the TerraStar satellite.

```
assignlbandbeam auto
```

To confirm tracking of an L-Band signal, log the L-Band tracking status information by entering the following command:

```
log lbandtrackstata
```

If receiving TerraStar service, the sixth field following the header (tracking status word) of the `LBANDTRACKSTAT` log will be `00c2`, as shown in the following example:

```
#LBANDTRACKSTATA, COM1, 0, 73.5, FINESTEERING,
1769, 328196.000, 00000000, 29fd, 12602;1, "98W", 1539902500, 1200, 974c
00c2, 0, -316.186, 43.842, 4.3840, 61.920, 1088, 2, 2, 138176, 79, 0.0001*3e43cb7d
```



The latest services and coverage can be obtained from www.novatel.com/products/novatel-correct-ppp/. For additional information on TerraStar activation, contact NovAtel Customer Service at www.novatel.com/support or download the APN-061 NovAtel CORRECT with TerraStar from: www.novatel.com/support/search/items/Application%20Note

4.7.2 Veripos Subscriptions



Subscriptions to the Veripos Apex and Apex² marine services must be obtained directly from Veripos. A unit with a marine subscription can not be switched to a land subscription and vice versa.

A subscription is required to use the [Veripos services](#) for offshore marine applications. Contact Veripos sales at www.veripos.com/support.html to obtain a Service Access License (SAL) number. To activate the service, contact the Veripos Help Desk at +44 (0) 1224 527 104 or visit www.veripos.com/support.html. Provide the SAL number and the receiver's Veripos Serial Number (VSN). To obtain the receiver-specific VSN, enter the following command:

```
log veriposinfo
```

The log displays the VSN in the first field following the log header and also displays the status of your subscription.

To activate a subscription, the receiver must be powered and tracking an L-Band Veripos satellite prior to the planned activation time. Use the `ASSIGNLBANDBEAM` command to configure the receiver to track the Veripos satellite.



The latest services and coverage can be obtained from www.veripos.com. For additional information on Veripos activation, contact NovAtel Customer Service at www.novatel.com/support or download the APN-062 NovAtel CORRECT with Veripos from: www.novatel.com/support/search/items/Application%20Note

4.7.3 OmniSTAR[®]



OmniSTAR service is not supported for OEM6 products sold after October 24, 2013. If unsure whether the receiver is OmniSTAR capable, contact NovAtel Sales at www.novatel.com/where-to-buy/sales-offices, NovAtel Customer Support at www.novatel.com/support or visit www.novatel.com/products/novatel-correct.

A subscription is required to use the OmniSTAR service. To obtain a subscription, contact OmniSTAR at 1-888-883-8476 or 713-785-5850. Provide the receiver's OmniSTAR serial number (which is different from the NovAtel serial number). To obtain the OmniSTAR serial number, enter the following command:

```
log lbandinfo
```

The log displays the L-Band serial number in the fifth field following the log header. The log also provides the status of your subscription. Refer to the LBANDINFO log in the [OEM6 Family Firmware Reference Manual](#) (OM-20000129) for more information.

To activate the subscription, the receiver must be powered and tracking an L-Band satellite. When advised by OmniSTAR of the appropriate satellite frequency and data link rate for your location, use the `ASSIGNLBAND` command to configure your receiver.



The latest frequencies can be obtained from: www.omnistar.com.

Example:

```
assignlband omnistar 1557855 1200
```

To confirm tracking of an L-Band signal, log the L-Band status information by entering the following command:

```
log lbandstat
```

If receiving OmniSTAR HP, the fifth field of the LBANDSTAT log should be 00c2, as shown in the following example:

```
LBANDSTAT COM1 0 81.0 FINESTEERING 1596 235136.000 00000000 d1c2 5968
<1557854678 48.98 1098.9 0.00 00c2 0000 153860 545 0 0000 0201 154019
68000000 00000000
```

Refer to the NovAtel application note [APN-051 Positioning Modes of Operation](#) for OmniSTAR specifics.

4.8 RTK ASSIST™

RTK ASSIST is a feature that enables centimetre-level accuracies to be maintained through extended RTK correction outages. With RTK ASSIST, RTK-dependent operations can continue through RTK correction outages as long as 20 minutes.

RTK ASSIST uses correction data provided by TerraStar. To obtain these corrections, an L-Band capable receiver is required and L-Band tracking must be enabled using the `ASSIGNLBANBEAM` command.

RTK ASSIST also requires a subscription to the RTK ASSIST service. To obtain a subscription, contact your local NovAtel sales representative or visit www.novatel.com/products/terraStar-gnss-corrections. The NovAtel product serial number (PSN) is needed to obtain a subscription. The PSN is available from the `VERSION` log.

RTK ASSIST is available as soon as the rover receiver has at least one valid RTK solution and has received the RTK ASSIST correction data. If an RTK correction outage occurs, then RTK ASSIST will maintain RTK mode until the subscription-permitted RTK ASSIST duration is exceeded. A shorter, user-defined RTK ASSIST time out can also be set using the `RTKASSISTTIMEOUT` command. Normal RTK operation will seamlessly resume if RTK corrections are restored at any point while RTK ASSIST is operating.

RTK ASSIST will report the RTK solution type that was present before RTK corrections were lost, unless the estimated solution standard deviation exceeds the threshold set by the `RTKINTEGCRITERIA` command. If this occurs, then integer RTK solutions will be downgraded to their float RTK equivalent.

RTK ASSIST is enabled by default, but can be disabled using the `RTKASSIST` command. To monitor the status of RTK ASSIST, view the `RTKASSISTSTATUS` log.

Refer to the [OEM6 Family Firmware Reference Manual](#) (OM-20000129) for information about the commands and logs referenced in this section.



RTK ASSIST typically provides 4 cm accuracy. However, if the RTK outage occurs during the first 30 minutes of receiver operation, the position accuracy provided by RTK ASSIST may be lower.

4.9 Transferring Time Between Receivers

The `ADJUST1PPS` command is used as part of the procedure to transfer time between receivers. The number of Pulses Per Second (PPS) is always set to 1 with this command. It is typically used when the receiver is not adjusting its own clock and is using an external reference frequency.

The `TIMESYNC` log is also used to synchronize time between receivers. It contains a time status field that may show `COARSE` or `FINE`, among others. For a complete list of the time status values and definitions, refer to the *GPS Time Status* section of the [OEM6 Family Firmware Reference Manual](#) (OM-20000129).

Section 4.9.3, Procedures to Transfer Time on page 69 provides details on the time transfer procedure. Terms used in the procedure are defined in *Section 4.9.2, Time Definitions* on page 68. Refer also to the `ADJUST1PPS` command and the `TIMESYNC` log descriptions in the [OEM6 Family Firmware Reference Manual](#) (OM-20000129).



The terms PPS and TIMEMARK are synonymous.

4.9.1 GPS to Receiver Time Synchronization

Receiver time synchronization with GPS time does not occur until the receiver locks onto the first satellite. The GPS L1 signal has two main streams of data modulated on the carrier. These data streams are the C/A code (1.023 MHz rate) and the P(Y) code (10.23 MHz rate). Additionally, a navigation message (at a 50 Hz rate) contains GPS satellite data including the ephemeris, clock corrections and constellation status. This navigation message is encoded on both the C/A and P(Y) codes. The navigation message is transmitted via individual subframes and each subframe is 300 bits in length. With the 50 Hz data bit rate there is a new subframe transmitted every six seconds.

4.9.2 Time Definitions

The following are related definitions:

Coarse Time

Each subframe contains the transmit time of the next subframe in seconds of GPS Time of Week (TOW). After the first subframe is collected and decoded by the receiver, an approximate calculation of the receiver clock offset can be made. The receiver clock offset is the difference between GPS time and internal receiver time. The calculation is based on subframe transmit time and the approximate propagation time from the satellite signal to the receiver. The position of the satellite and receiver clock offset are used to re-initialize the seconds counter on the receiver, resulting in receiver/GPS time synchronization. The accuracy of the receiver time is expected to be within 30 milliseconds (ms) of GPS time. This initial synchronization is referred to as coarse time and is indicated by `COARSE` in the time status field of the `TIMESYNC` log.

Fine Time

When at least four satellites are acquired to calculate the antenna position, a more accurate estimate of the receiver clock offset is calculated. The new receiver clock offset is used to synchronize the receiver clock even closer to GPS time. This is referred to as fine time and appears as `FINE` or `FINESTEERING` in the time status field of the `TIMESYNC` log. Fine time accuracy is a function of the GPS constellation status. For the Standard Position Service (SPS) the time accuracy is specified as 300 ns (1 sigma), assuming that clock steering is enabled.

Fine Clock

An OEM6 family receiver tracking satellites and has a `FINE` or `FINESTEERING` receiver clock state.

Cold Clock

An OEM6 family receiver that needs to have its clock synchronized with the Fine receiver. It may have any clock state (except `FINE` or `FINESTEERING`) that includes `UNKNOWN`.

Warm Clock

An OEM6 family receiver that has its clock adjusted to greater than 500 ms. Refer to the TIME log to view the clock offset.



The [OEM6 Family Firmware Reference Manual](#) (OM-20000129) contains details of the logs mentioned above.

4.9.3 Procedures to Transfer Time

These procedures are used to transfer time between a fine clock and a cold or warm clock GPS receiver.



When connecting two receivers to transfer time, disable responses on the COM port used to connect the receivers by issuing the following command on both receivers:

```
interfacemode comX novatel novatel none
```

Where comX is the port used on the receiver.

Transfer COARSE Time (<10 ms) from a Fine Clock to a Cold Clock GPS Receiver

1. Connect a COM, USB or Ethernet port from the fine clock receiver to the cold clock receiver (for example, COM2 on the fine clock receiver to COM3 on the cold clock receiver) as shown in *Figure 30, Transfer COARSE Time from Fine Clock to Cold Clock Receiver* on page 69. Configure both ports to the same baud rate and handshaking configurations.

Figure 30: Transfer COARSE Time from Fine Clock to Cold Clock Receiver

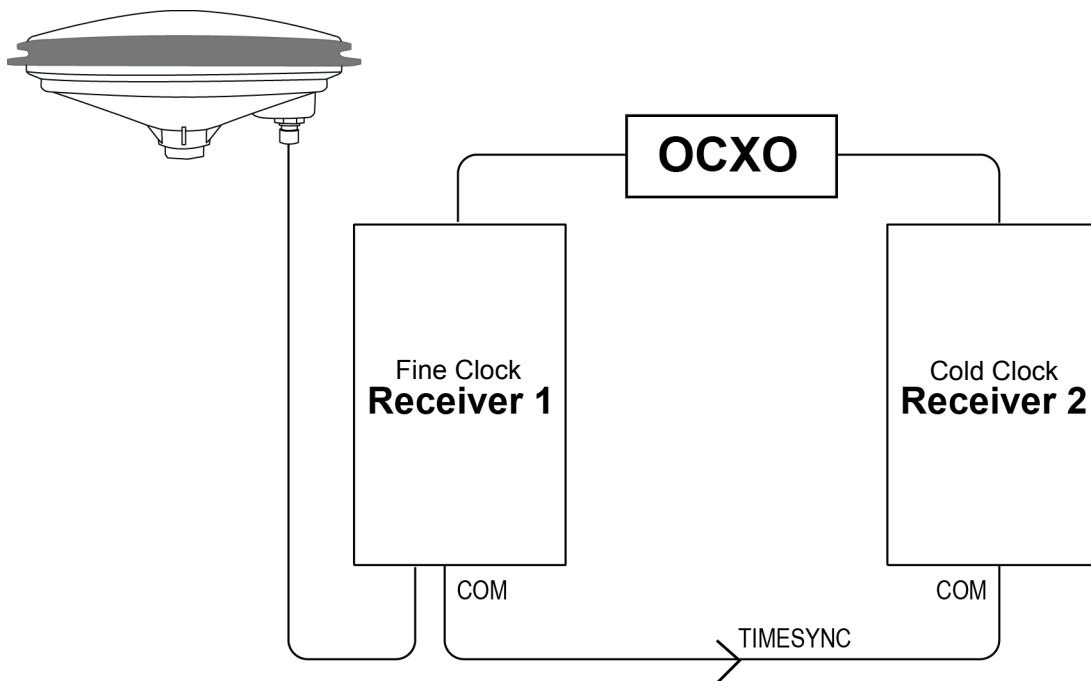

2. Issue the following command to the fine clock receiver:

```
log com2 timesyncb ontime 1
```

3. Issue the following command to the cold clock receiver:

```
adjustlpps time
```

When the cold clock receiver receives the TIMESYNC log, it sets its clock with a 100 ms transfer delay allowance.

Transfer FINE Time (<50 ns) from a Fine Clock to a Cold Clock GPS Receiver

1. Connect a COM, USB or Ethernet port from the fine clock receiver to the cold clock receiver (for example, COM2 on the fine clock receiver to COM3 on the cold clock receiver), as shown in *Figure 31, Transfer FINE Time from Fine Clock to Cold Clock Receiver* on page 70. Configure both ports to the same baud rate and handshaking configurations.

Figure 31: Transfer FINE Time from Fine Clock to Cold Clock Receiver

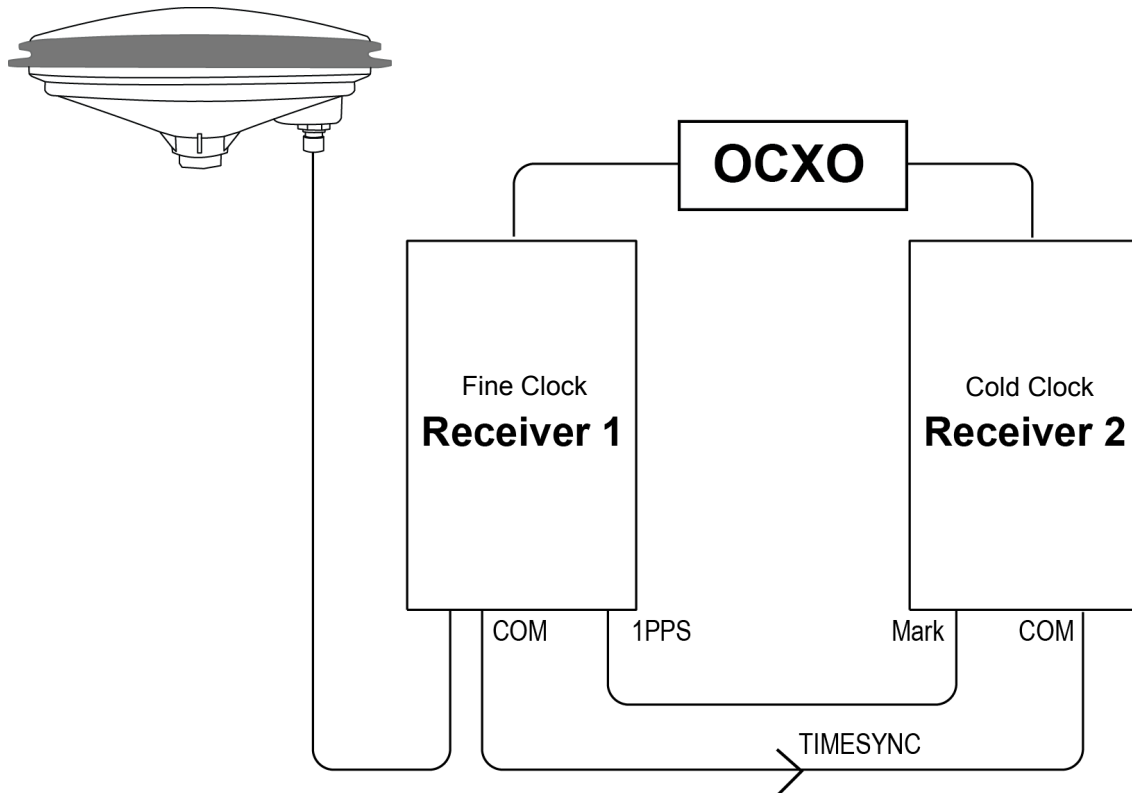

2. Issue the following command to the fine clock receiver:

```
log com2 timesyncb ontime 1
```

3. Connect the 1PPS signal of the fine clock receiver to the Mark 1 input (Event1) of the cold clock receiver.
4. Issue the following command to the cold clock receiver:

```
adjust1pps markwithtime
```

When the cold clock receiver receives the 1PPS event from the fine clock receiver, it checks to see if a valid TIMESYNC log has arrived within 200 ms of the last 1PPS event. If so, it sets the cold clock receiver clock to the time of the fine clock receiver. See *Figure 33, 1 PPS Alignment* on page 72.

Transfer FINE Time from a Fine Clock to a Warm Clock GPS Receiver

1. Connect the 1 PPS signal of the fine clock receiver to the Mark 1 input (Event1) of the warm clock receiver as shown in *Figure 32, Transfer FINE Time from Fine Clock to Warm Clock Receiver* on page 71.

Figure 32: Transfer FINE Time from Fine Clock to Warm Clock Receiver

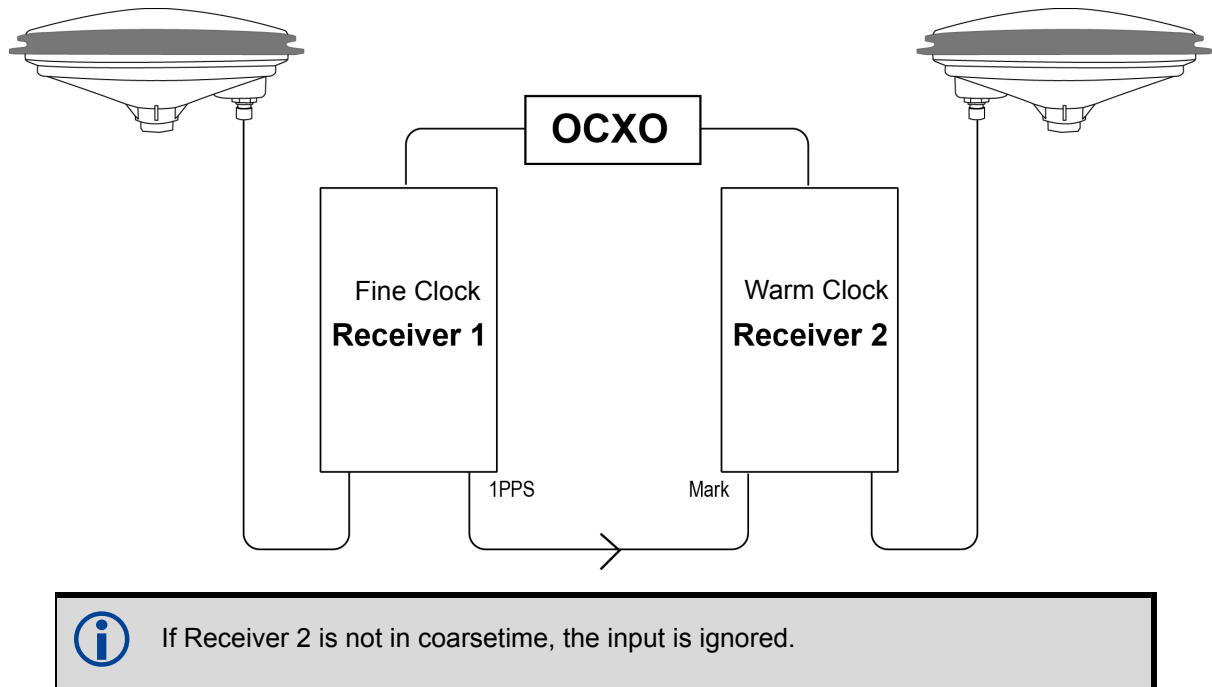

2. Issue the following command to the warm clock receiver:

```
adjust1pps mark
```

The phase of the warm clock receiver clock is adjusted by the fractional measurement of the fine clock receiver's 1 PPS mark input event. In other words, it synchronizes the warm clock receiver's 1 PPS to the incoming 1 PPS of the fine clock receiver. It does not adjust the one second TOW counter or the receiver's week number. This procedure is used to make small corrections to the warm clock receiver's clock.

Figure 33: 1 PPS Alignment

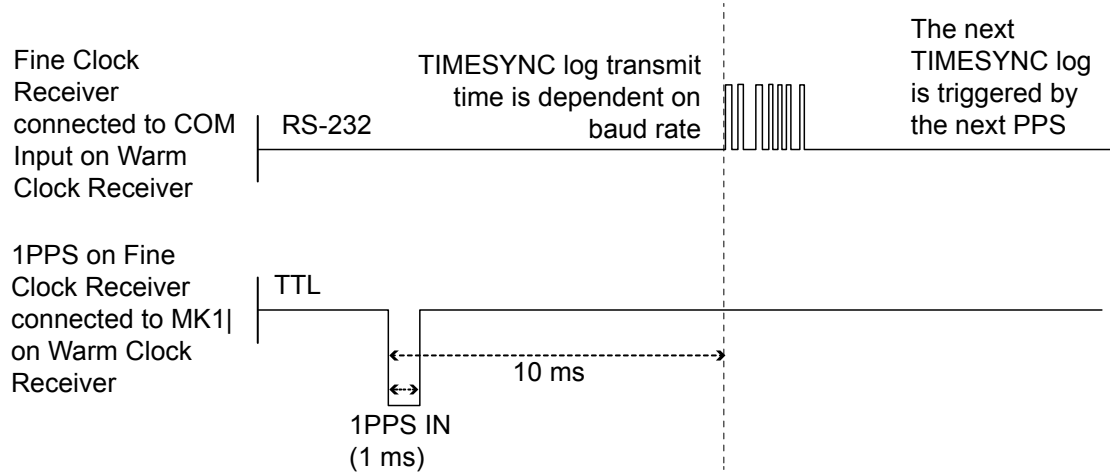

The examples shown in *Figure 30, Transfer COARSE Time from Fine Clock to Cold Clock Receiver* on page 69, *Figure 31, Transfer FINE Time from Fine Clock to Cold Clock Receiver* on page 70 and *Figure 32, Transfer FINE Time from Fine Clock to Warm Clock Receiver* on page 71 are for the transfer of time. If a position is needed, the receiver must be tracking satellites and must have a valid almanac.

4.10 Additional Features and Information (Card and Enclosure)

This section contains information on additional features of the OEM6 family receivers.

4.10.1 Universal Serial Bus (USB)

OEM6 family receivers come with NovAtel USB drivers for Microsoft Windows 2000, Windows XP, Windows Vista and Windows 7 to provide three virtual serial ports over a single USB 2.0 connection using USB D(+) and USB D(-) signals (refer to *Table 10, Available USB Signals on Receivers* on page 73). The USB drivers are digitally signed and officially supported on Microsoft Windows XP, Windows Vista and Windows 7. They can also be installed on Microsoft Windows 2000 and Windows Server 2003 but are not WHQL signed in those applications.

Table 10: Available USB Signals on Receivers

<p>615</p> <p>617</p> <p>617D</p>	<p>Pin 3 D(-) and Pin 4 D(+) on P1101 (main header). Pin 4 is multiplexed with COM3</p>
<p>628</p>	<p>Pin 21 D(-) and Pin 22 D(+) of P1500</p>
<p>638</p>	<p>USB0 (device): Pin 5 (D-) and Pin 3 (D+) of P4001 USB1 (host): Pin 79 (D+) and Pin 81 (D-) of J4101 USB2 (host): Pin 84 (D+) and Pin 86 (D-) of J4101</p>
<p>FPk6</p> <p>FPk6D</p>	<p>USB mini connector</p>

For the OEM638, only the USB0 (device) port supports these virtual serial ports. The USB1 and USB2 (host) ports are used for memory sticks, supplying external storage. The use of external storage is not supported on the OEM615, OEM617, OEM617D, OEM628 or FlexPak6.

The three virtual serial ports are available to existing Windows applications which use COM ports to communicate (for example, HyperTerminal and NovAtel Connect). The NovAtel USB drivers assign COM port numbers sequentially following any existing ports on the computer. For example, if a computer has COM1 and COM2 ports, the NovAtel USB drivers assign COM3 to USB1, COM4 to USB2 and COM5 to USB3.

A computer has several USB ports. The assignment of COM port numbers is tied to a USB port on the computer. This allows receivers to be switched without Microsoft Windows assigning new COM ports. However, if the receiver is connected to a different physical USB port, Windows detects the receiver's presence and assigns three new COM port numbers.

The NovAtel USB Configuration Utility, installed with the NovAtel USB drivers, is used to change the COM port numbers assigned to the virtual serial ports. Refer to the PC Utilities manual for instructions. You can also check for updates to the drivers or release notes at www.novatel.com/support.

The USB ports are particularly sensitive to damage from ESD. NovAtel recommends that conductors attached to the USB D+ and D- signal pins are terminated.

4.10.2 CAN Bus (not available on the FlexPak6D)

OEM6 cards incorporate a CAN Bus controller that supports physical layer signals and low level messages specified in the appropriate sections of the J1939 and ISO11783 standards. Manufacturers can also create messages specific to their application without violating these standards. To facilitate manufacturer messages, NovAtel provides an Application Program Interface (API). To obtain information about this API, contact www.novatel.com/support/.



There are no CAN transceivers on the OEM615, OEM617, OEM617D or OEM628. These cards require external CAN transceivers and proper bus terminations.

615

The OEM615, OEM617 and OEM617D have two CAN ports: CAN1 and CAN2 support up to 1 Mbps. CAN1 is multiplexed with user VARF and EVENT2, so the following commands must be issued to enable CAN1:

617

FREQUENCYOUT DISABLE

617D

MARKCONTROL MARK2 DISABLE

628

The OEM628 card has two CAN ports: CAN1 and CAN2, both of which are brought out to the expansion connector, P1502. CAN1 and CAN2 both support applications up to 1 Mbps.

638

The OEM638 card has two CAN ports: CAN1 and CAN2, both of which are brought out to the expansion connector, J4101. CAN1 and CAN2 both support applications up to 1 Mbps.

CAN interfaces can be accessed using NovAtel's API, but shared signals must be disabled to avoid conflicts. Refer to *Section A.1.1, Physical Description* on page 114, *Section D.1.1, Physical Description* on page 146 and *Section E.1.1, Physical Description* on page 163 in this manual for pin-out information.



CAN Bus functionality can be controlled through NovAtel's optional API software. The API header file includes documentation on using the CAN bus.

FPk6

The FlexPak6 has a CAN port that supports applications up to 1 Mbps (refer to *Appendix F, FlexPak6 Technical Specifications* on page 190 for input/output).

OEM6 receivers support only the following NMEA2000 Parameter Group Messages (PGN) at these fixed rates over the CAN bus:

- PGN 129029 GNSSPositionData (1 Hz)
- PGN 129025 GNSSPositionRapidUpdate (10 Hz)
- PGN 129026 COGandSOGRapidUpdate (10 Hz)
- PGN 129027 PositionDeltaRapidUpdate (10 Hz - available on OEM628 platforms only)



The CAN must be activated by entering the `SETCANNNAME` command. To have the CAN set up automatically at subsequent start ups, also send the `SAVECONFIG` command. For information about these commands, see the [OEM6 Family Firmware and Reference Manual](#) (OM-20000129).



Details for the PGN messages can be found in the NMEA2000 specification which can be purchased directly from the National Marine Electronics Association (www.nmea.org/).

4.10.3 Strobes

OEM6 family receivers have inputs and outputs, referred to as strobes, that provide status and synchronization signals. Not all strobes are provided on all receivers. Detailed information about OEM6 family strobes can be found in the following tables.

615	Table 15, OEM615 Strobes on page 120 and Table 16, OEM615 Strobe Electrical Specification on page 120
617	Table 20, OEM617 Strobes on page 130 and Table 21, OEM617 Strobe Electrical Specification on page 130
617D	Table 25, OEM617D Strobes on page 140 and Table 26, OEM617D Strobe Electrical Specification on page 140
628	Table 30, OEM628 Strobes on page 153 and Table 31, OEM628 Strobe Electrical Specifications on page 153
638	Table 37, OEM638 Strobes on page 169 and Table 38, OEM638 Strobe Electrical Specifications on page 170
FPk6	Table 46, FlexPak6 Port Pin-Out Descriptions on page 191
FPk6D	Table 49, FlexPak6D Port Pin-Out Descriptions on page 195

638	A number of pins on the OEM638 card can have multiple functions. Refer to the <code>IOCONFIG</code> , <code>EVENTINCONTROL</code> and <code>EVENTOUTCONTROL</code> commands in the OEM6 Family Firmware Reference Manual (OM-20000129) for details.
------------	---

4.10.4 Status Indicator

OEM6 family receiver cards have an LED indicator to provide receiver status.

615	Refer to Figure 10, OEM615 Connector and Indicator Locations on page 35
617	Refer to Figure 11, OEM617 Connector and Indicator Locations on page 36
617D	Refer to Figure 12, OEM617D Connectors and Indicators on page 36
628	Refer to Figure 13, OEM628 Connector and Indicator Locations on page 37
638	Refer to Figure 14, OEM638 Connector and Indicator Locations on page 38

The LED blinks green on and off, approximately once per second, to indicate normal operation. If the indicator is red, the receiver is not working properly. The indicator's operation is described in *Chapter 5, Built-In Status Tests* on page 81.

FPk6

FPk6D

Refer to *Table 6, FlexPak6 Status Indicators and Connector Labels* on page 49 and *Table 7, FlexPak6D Status Indicators and Connector Labels* on page 50 for details.

4.10.5 External Oscillator

For applications requiring greater precision than what is possible using the on-board Voltage Controlled, Temperature Compensated Crystal Oscillator (VCTCXO), the OEM628 or OEM638 may need to be connected to an external, high stability oscillator, at 5 MHz or 10 MHz.

615

617

617D

FPk6

FPk6D

The OEM615, OEM617, OEM617D, FlexPak6 and FlexPak6D do not have an external oscillator connection.

Connect a cable from the external oscillator to the receiver's external oscillator input connector. For the OEM628 and OEM638, a MMCX female connector (J101) is used as shown in *Figure 13, OEM628 Connector and Indicator Locations* on page 37 and *Figure 14, OEM638 Connector and Indicator Locations* on page 38. The receiver does not have to be powered down during this operation. However, if handling a card directly, observe anti-static practices. The OEM628 and OEM638 input impedance is 50 ohms.

When the external oscillator is installed, use the `EXTERNALCLOCK` command (refer to the [OEM6 Family Firmware Reference Manual](#) (OM-20000129) for details) to set the clock type (e.g. cesium, rubidium or ovenized crystal) and frequency.

4.10.6 Antenna LNA Power

NovAtel antennas and coaxial cables meet receiver RF input gain requirements. NovAtel antennas are equipped with built-in LNAs that provide 26 dB of gain to the satellite signal received. The power to the antenna LNA is provided through the receiver’s RF port center conductor. To achieve the required input gain to the receiver, NovAtel coaxial cables are designed to introduce no more than 10 dB loss. Antenna supply over current protection limits the LNA power.

<p>615 617D</p>	<p>OEM615 and OEM617D provide +5 VDC ±5% at a maximum of 100 mA. The amount of current the receiver can provide to the antenna depends upon the input voltage provided to pin 1 on the P1101 connector according to the de-rating curve: $I_{out} < 0.1W / (V_{in} - 5V)$ where V_{in} is 6 V to 12 V</p>
<p>617</p>	<p>OEM617 provides +5 VDC ±5% at a maximum of 200 mA. The amount of current the receiver can provide to the antenna depends upon the input voltage provided to pin 1 on the P1101 connector according to the de-rating curve: $I_{out} < 0.2W / (V_{in} - 5V)$ where V_{in} is 6 V to 12 V</p>
<p>628</p>	<p>OEM628 provides selectable 3.3 V or +5 VDC ±5% at a maximum of 100 mA</p>
<p>638</p>	<p>OEM638 provides selectable 3.3 V or +5 VDC ±5% at a maximum of 200 mA. The OEM638 also includes an external LNA supply pin that can accept up to 6-18 VDC</p>

638 For the OEM638 receiver, it is possible to supply power to the LNA of an active antenna either from the antenna port of the receiver itself or from an external source. Use the `ANTENNAPOWER` command to enable (default) or disable electrical power from the internal power source of the receiver to the LNA of an active antenna. Refer to the [OEM6 Family Firmware Reference Manual](#) (OM-20000129) for command details.

4.10.7 Ethernet **628** **638** **FPk6**

OEM638, OEM628 and FlexPak6 receivers are equipped with a 10/100baseT Ethernet port that supports IPv4 Internet layer, TCP/IP transport and telnet. Users can conduct remote debugging, accept MRTCA (modified RTCA) data and download firmware. OEM6 family receivers are also equipped with NTRIP Version 2.0 (Networked Transport of RTCM via Internet Protocol) client and server capability.

 The OEM628 and OEM638 do not have Ethernet magnetics or RJ45 connector. If using the OEM6 Ethernet connectivity, the distance between the RJ45 connector and the magnetics must be no more than 10 inches (25.4 cm), and the distance between the device and the magnetics must be no more than 1.5 inches (3.8 cm).

Refer to *Chapter 6, Ethernet Configuration* on page 86 for instructions on configuring Ethernet and NTRIP.

 Ethernet is not available on the OEM615, OEM617, OEM617D and FlexPak6D.

4.11 Logging and Retrieving Data Overview 638

The OEM638 contains 4 gigabytes of memory for onboard data storage. Data can be logged to internal memory and downloaded for post-processing in a variety of ways.

Logging can be initiated by issuing commands using Wi-Fi or Ethernet (recommended). Logged data stored in the flash memory can also be retrieved using Wi-Fi or Ethernet (recommended) or downloaded using USB (refer to *Section E.1.7, USB Interfaces* on page 185 for configuration details).



If ICOM port security is enabled (using the `IPSERVICE` command), commands are refused until the `LOGIN` command is issued. Refer to *Section 2.6, OEM638 Card Security* on page 43 of this manual and the [OEM6 Family Firmware Reference Manual](#) (OM-20000129) for command details.

A log file must be open for logs to be recorded and only one log at a time can be open.



A maximum of 255 files can be stored (depending on individual file sizes).

4.11.1 Onboard Memory

The `DIRENT` log lists the current contents of the receiver's onboard memory. Up to 512 files can be listed using this message. Refer to the `DIRENT` log in the [OEM6 Family Firmware Reference Manual](#) (OM-20000129) for details.

4.11.2 Remote Logging Initiation

Once a Wi-Fi or Ethernet connection is established, send the `LOGFILE OPEN` command to begin logging data.

4.11.3 Manual Retrieval of Logged Data

By default, USB is configured to automatically download data stored on the internal flash memory to a memory stick. To change to manual download, use the `SETFILECOPYMODE` command to change the functionality of USB.

If USB functionality is changed to manual, issue the `DOSCMD` command to manually transfer stored data to a memory stick (internal flash storage only). Refer to [OEM6 Firmware Reference Manual](#) (OM-20000129) for details on each command.

4.11.4 Remote Retrieval of Logged Data

The FTP server on the OEM638 card allows access to the internal flash memory. There is a limitation of one connection at any given time. This not only means that only one user can access the FTP server at a time but the FTP Client software must be set to only use one connection.



The default password is the PSN of the receiver. Before connecting the OEM638 to a network, use the `SETADMINPASSWORD` command to change the default password. Refer to [OEM6 Firmware Reference Manual](#) (OM-20000129) for command details.

Use the `LOG` command to specify the logs to send to the onboard memory. For example, a standard logging configuration for GPS-INS-only post-processing applications would be:

```
LOG FILE RANGECPB ONTIME 1
```

```
LOG FILE RAWEPHEMB ONNEW
LOG FILE RAWIMUSB ONNEW
LOG FILE IMUTOANTOFFSETSB ONNEW
```



If a Wi-Fi connection is lost during the downloading of logs, the log is resent, in entirety, once network communication is reestablished.

4.11.5 Naming Logs

File names for logs can be customized or the OEM638 can be set to automatically name files.

4.11.6 Manual Log File Naming

Use NovAtel Connect or HyperTerminal to name logged files using the `LOGFILE` command.

If the file name entered already exists, the command returns an error. Use the `LOGFILESTATUS` log to view errors, determine if a log file is open or closed or if the internal storage device is busy.

Automatic Log File Naming

If a name is not supplied to the `LOGFILE` command, a file name is automatically generated based on the PSN of receiver and an automatically incrementing number beginning at one. If a log in the sequence number is deleted, the number is recycled for use in order.



Refer to the [OEM6 Family Firmware Reference Manual](#) (OM-20000129) for information on the `LOGFILE` command.

4.11.7 Stop Logging

Issue the `LOGFILE CLOSE` command to end logging.

4.11.8 Reading Data and Post-Processing

Logs can be directed to any of the OEM638 communication ports and can be automatically generated when new or changed data becomes available or at regular intervals. Data can be collected through NovAtel Connect using the *Logging Control Window*.

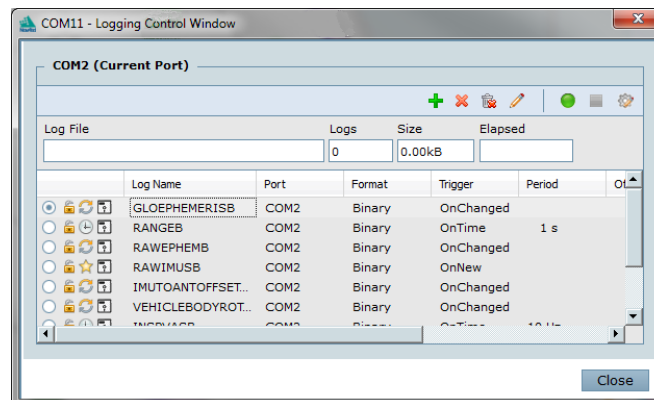

Refer to the NovAtel Connect Help available from within the utility Help or the `.chm` file bundled with the software comprehensive logging instructions.

4.11.9 Pass-Through Logging

The pass-through logging feature enables the GNSS receiver to redirect any ASCII or binary data that is input at a specified COM port or USB port, to any specified receiver COM or USB port. This capability, in conjunction with the SEND command, allows the receiver to perform bidirectional communications with other devices such as a modem, terminal or another receiver.

There are several pass-through logs: PASSCOM1, PASSCOM2, PASSCOM3, PASSXCOM1, PASSXCOM2, PASSXCOM3, PASSUSB1, PASSUSB2, PASSUSB3, PASSICOMX, PASSNCOM and PASSAUX are available on OEM6 family receivers for logging through serial ports. Refer to the PASSCOM logs in the [OEM6 Family Firmware Reference Manual](#) (OM-20000129) for details.

5.1 Overview

The Built-In Status Test monitors system performance and status to ensure the receiver is operating within specifications. The test detects an exceptional condition and informs the user through one or more indicators. The receiver status system is used to configure and monitor the indicators:

1. Receiver status word (included in the header of every message)
2. ERROR strobe signal (refer to the Strobes table in the Appendix for each card)
3. RXSTATUSEVENT log
4. RXSTATUS log
5. Status LED

In normal operation, the error strobe is driven low and the status LED on the receiver flashes green once every second. When an unusual and non-fatal event occurs (for example, there is no valid position solution), a bit is set in the receiver status word. Receiver operation continues normally, the error strobe remains off and the LED continues to flash green. When the event ends (for example, when there is a valid position solution), the bit in the receiver status word is cleared.

When a fatal event occurs (for example, a receiver hardware failure), a bit is set in the receiver error word, part of the RXSTATUS log, to indicate the cause of the problem. Bit 0 is set in the receiver status word to show that an error occurred, the error strobe is driven high and the status LED flashes red and yellow showing an error code. An RXSTATUSEVENT log is generated on all ports to show the cause of the error. Receiver tracking is disabled but command and log processing continues to allow error diagnosis. Even if the source of the error is corrected, the receiver must be reset to resume normal operation.

Two scenarios describe factory default behavior. These behaviors can be customized to better suit an individual application. RXSTATUSEVENT logs can be disabled completely with the `UNLOG` command. RXSTATUSEVENT logs can be generated when a receiver status bit is set or cleared with the `STATUSCONFIG SET` and `STATUSCONFIG CLEAR` commands. Bits in the receiver status word can also be promoted to act like error bits with the `STATUSCONFIG PRIORITY` command.

5.2 Receiver Status Word

The receiver status word indicates the current status of the receiver. This word is found in the header of all logs and in the RXSTATUS log. In addition, the receiver status word is configurable.

The importance of the status bits with priority masks can be determined. For receiver status, setting a bit in the priority mask causes the condition to trigger an error. The error causes the receiver to idle all channels, turn off the antenna and disable the RF hardware, just like it would if a bit in the receiver error word is set. Setting a bit in an Auxiliary Status priority mask causes the condition to set the bit in the receiver status that corresponds to the auxiliary status.

Use the `STATUSCONFIG` command to configure the various status mask fields in the RXSTATUS log. Use the masks to specify whether various status fields generate errors or event messages when set or cleared.

Refer to the RXSTATUS log, RXSTATUSEVENT log and `STATUSCONFIG` command in the [OEM6 Family Firmware Reference Manual](#) (OM-20000129) for more detailed descriptions of these messages.

5.3 Error Strobe Signal

The error strobe signal is one of the I/O strobes. The strobe signal is driven low when the receiver is operating normally. When the receiver is in the error state and tracking is disabled, the error strobe is driven high. This can be caused by a fatal error or by an unusual receiver status indication that the user has promoted to be treated like a fatal error. Once on, the error status remains high until the cause of the error is corrected and the receiver is reset. See also *Section 4.10.3, Strobes* on page 75.

638 The Error pin on the OEM638 is multiplexed with EVENT_IN4 and is software configurable.

5.4 RXSTATUSEVENT Log

The RXSTATUSEVENT log is used to output event messages, as indicated in the RXSTATUS log.

On start up, the OEM6 family receiver is set to log the RXSTATUSEVENTA log ONNEW on all ports. Remove this message using the UNLOG command.

Refer to the RXSTATUSEVENT log in the [OEM6 Family Firmware Reference Manual](#) (OM-20000129) for a more detailed description of this log.

5.5 RXSTATUS Log

5.5.1 Overview

The Receiver Status log (RXSTATUS) provides system status and configuration information in a series of hexadecimal words.

The status word is the third field after the header, as shown in *Figure 34, Location of Receiver Status Word* on page 82.

Figure 34: Location of Receiver Status Word

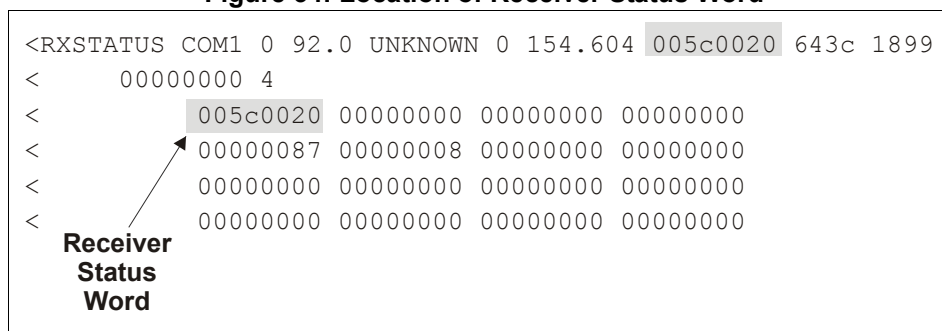

Each bit in the status word indicates the status of a specific receiver condition or function. If the status word is 00000000, the receiver is operating normally. The numbering of the bits is shown in *Figure 35, Reading the Bits in the Receiver Status Word* on page 82.

Figure 35: Reading the Bits in the Receiver Status Word

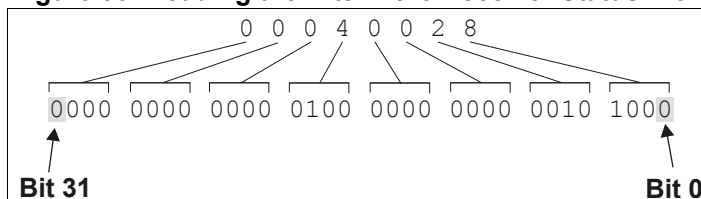

If the receiver status word indicates a problem, see *Section 7.1, Examining the RXSTATUS Log* on page 99.

5.5.2 Error Word

The error field contains a 32-bit word. Each bit in the word is used to indicate an error condition. Error conditions may result in damage to the hardware or erroneous data, so the receiver is put into an error state. If any bit in the error word is set, the receiver sets the error strobe line, flashes the error code on the status LED, broadcasts the RXSTATUSEVENT log on all ports (unless the user has unlogged it), idles all channels, turns the antenna off and disables the RF hardware. To override the error state, reset the receiver.

The receiver can be configured to generate event messages triggered by status conditions. Receiver Error words automatically generate event messages. These event messages are output in RXSTATUSEVENT logs (see also *Section 5.5.6, Set and Clear Mask for all Status Code Arrays* on page 84).

The error word is the first field after the log header in the RXSTATUS log, as shown in the example in *Figure 36, Location of Receiver Error Word* on page 83.

Figure 36: Location of Receiver Error Word

```

<RXSTATUS COM1 0 92.0 UNKNOWN 0 154.604 005c0020 643c 1899
< 00000000 4
< 005c0020 00000000 00000000 00000000
< 00000087 00000008 00000000 00000000
< 00000000 00000000 00000000 00000000
< 00000000 00000000 00000000 00000000
    
```

Receiver Error Word

Figure 37, Reading the Bits in the Receiver Error Word on page 83 shows an example of a receiver error word.

Figure 37: Reading the Bits in the Receiver Error Word

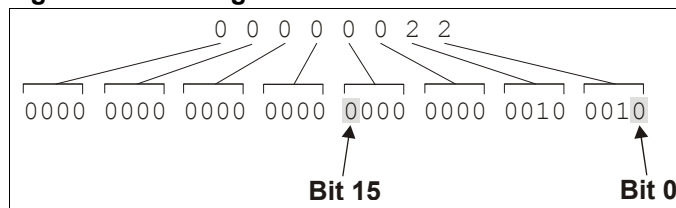

Refer to the RXSTATUS and the RXSTATUSEVENT logs in the [OEM6 Family Firmware Reference Manual](#) (OM-20000129) for more detailed log descriptions. If the receiver error word indicates an error, refer to *Section 7.1, Examining the RXSTATUS Log* on page 99.

5.5.3 Status Code Arrays

There are currently 4 status code arrays:

- receiver status word
- auxiliary 1 status
- auxiliary 2 status
- auxiliary 3 status

Each status code array consists of four 32-bit words (the status word, a priority mask, a set mask and a clear mask). The status word is similar to the error word, with each of the 32 bits indicating a condition. The mask words are used to modify the behavior caused by a change in one of the bits in the associated status words. Each bit, in any mask, operates on the bit in the same position in the status word. For example, setting bit 3 in the priority mask changes the priority of bit 3 in the status word.

5.5.4 Receiver Status Code

The receiver status word is included in the header of all logs. It has 32 bits that indicate certain receiver conditions. If any of these conditions occur, a bit in the status word is set. Unlike the error word bits, the receiver continues to operate, unless the priority mask for the bit has been set. The priority mask bit changes the receiver status word into an error bit. Anything that results from an error bit becoming active also occurs if a receiver status and its associated priority mask bits are set.

5.5.5 Auxiliary Status Codes

The auxiliary status codes are only in the RXSTATUS log. The three arrays that represent the auxiliary status codes indicates the receiver state for information purposes only. The events represented by these bits typically do not cause receiver performance degradation. The priority mask for the auxiliary codes does not put the receiver into an error state. Setting a bit in the auxiliary priority mask results in the corresponding bit in the receiver status code to be set if any masked auxiliary bit is set. Bit 31 of the receiver status word indicates the condition of all masked bits in the auxiliary 1 status word. Likewise, bit 30 of the receiver status word corresponds to the auxiliary 2 status word and bit 29 to the auxiliary 3 status word.

Refer also to the RXSTATUS log in the [OEM6 Family Firmware Reference Manual](#) (OM-20000129) for a more detailed description.

5.5.6 Set and Clear Mask for all Status Code Arrays

The other two mask words in the status code arrays operate on the associated status word in the same way. These mask words are used to configure the bits in the status word that result in a RXSTATUSEVENT log broadcast. The set mask is used to turn logging on temporarily while the bit changes from the 0 to 1 state. The clear mask is used to turn logging on temporarily while the bit changes from a 1 to a 0 state. Note the error word does not have any associated mask words. Any bit set in the error word results in a RXSTATUSEVENT log broadcast (unless unlogged).

Refer also to the RXSTATUS log in the [OEM6 Family Firmware Reference Manual](#) (OM-20000129) for a more detailed description.

5.6 Status LED

The diagnostic LED provided on the OEM6 family cards blinks green on and off approximately once per second to indicate normal operation.

Error bits and status bits that have been priority masked as errors cause the LED to flash a code in a binary sequence. The binary sequence is a six flash (0.5 second on and 0.25 second off per flash) sequence followed by a one second delay. The sequence repeats indefinitely. If there are more than one error or status present, the lowest number appears as the flash code output. The codes are ordered to have the highest priority condition output first.

The first flash in the six flash sequence indicates if the code that follows is an error bit or a status bit. Error bits flash red and status bits flash yellow. The next five flashes are the binary number of the code (most significant bit first). A red flash indicates a one and a yellow flash indicates a zero. For example, for an error bit six, the binary number is 00110 so the output sequence is:

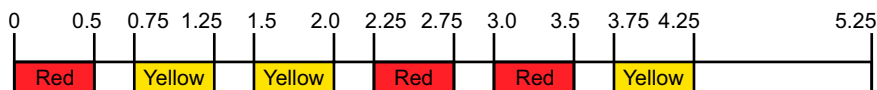

followed by a one second delay. The sequence repeats indefinitely until the receiver is reset.

In the example shown in *Figure 38, Status LED Flash Sequence Example* on page 85, the first flash in the sequence is red, meaning a bit is set in the receiver error word. The next five flashes give a binary value of 00111. Converting this value to decimal results in a value of seven. Therefore, bit seven of the receiver error word is set, indicating a problem with the supply voltage of the receiver's power circuitry.

Figure 38: Status LED Flash Sequence Example

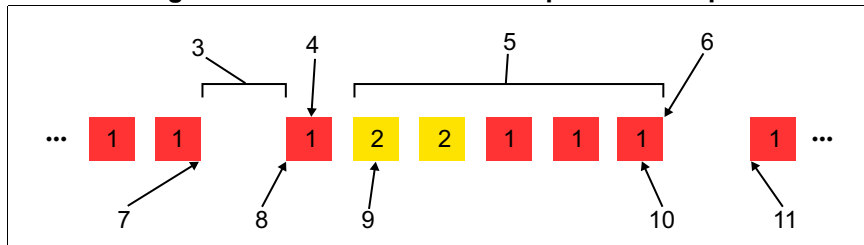

Reference	Description
1	Red
2	Yellow
3	1 Second Pause
4	Word Identifier Flash
5	Bit Identifier Flashes
6	End of Sequence
7	End of Previous Sequence
8	Beginning of Sequence
9	Most Significant Bit of Binary Value
10	Least Significant Bit of Binary Value
11	Start of Next Sequence

Refer to the RXSTATUS log and associated tables in [OEM6 Family Firmware Reference Manual](#) (OM-20000129) for more information about this log and receiver error status.

615

617

617D

FPk6D

Ethernet is not available on the OEM615, OEM617, OEM617D or FlexPak6D.

An Ethernet connection can be used to send commands to and obtain logs from Ethernet capable OEM6 receivers. An Ethernet connection can also be used to connect two receivers in a base/rover configuration.

This chapter describes how to configure the Ethernet port on an OEM6 receiver. It provides the step-by-step process for connecting to the OEM6 receiver through the Ethernet interface, setting up a base/rover configuration through Ethernet connectivity and utilizing the NTRIP interface. The Ethernet port connections for a computer connected to the receiver are also described for Windows 7 operating systems.

628

638

FPk6

The `SAVEETHERNETDATA` command can be issued to retain the Ethernet configuration settings after a `RESET/FRESET` command. The `ETHCONFIG` and `IPCONFIG` commands must be issued prior to using `SAVEETHERNETDATA`. Refer to the [OEM6 Family Firmware Reference Manual](#) (OM-20000129) for command details.

6.1 Required Hardware

The following hardware is required to set up an Ethernet interface to an OEM6 receiver:

- a user supplied computer with an available Ethernet, serial and USB port
- an Ethernet capable OEM6 receiver, such as an OEM628, OEM638 or FlexPak6



External Ethernet Magnetics are required for the OEM628 and OEM638 receiver cards. The OEM Development Kit can be used for Ethernet communication when connected to the OEM628 receiver.

- an RS-232 null modem cable or USB cable
- one or two CAT5 Ethernet cables
- a user supplied Ethernet network, hub or wired router (optional)
- one or two GNSS antennas
- one or two standard 5 meter 50 ohm TNC-to-TNC antenna cables

6.2 Static IP Address Configuration

For a static IP address configuration, unique IP addresses are assigned to both the OEM6 receiver and the computer. TCP/IP is used for the connection in this simple network. This configuration can also be used in a bench test environment to confirm Ethernet functionality.

For connections when an OEM6 receiver uses a static IP address configuration, refer to the following:

<div style="border: 1px solid black; border-radius: 50%; width: 30px; height: 30px; display: flex; align-items: center; justify-content: center; margin: 5px;">628</div> <div style="border: 1px solid black; border-radius: 50%; width: 30px; height: 30px; display: flex; align-items: center; justify-content: center; margin: 5px;">638</div>	<p>Figure 39, Cross-Over Ethernet Cable Configuration—OEM628 and OEM638 on page 87</p>
<div style="border: 1px solid black; border-radius: 50%; width: 30px; height: 30px; display: flex; align-items: center; justify-content: center; margin: 5px;">FPk6</div>	<p>Figure 40, Cross-Over Ethernet Cable Configuration—FlexPak6 on page 88</p>

Figure 39: Cross-Over Ethernet Cable Configuration—OEM628 and OEM638

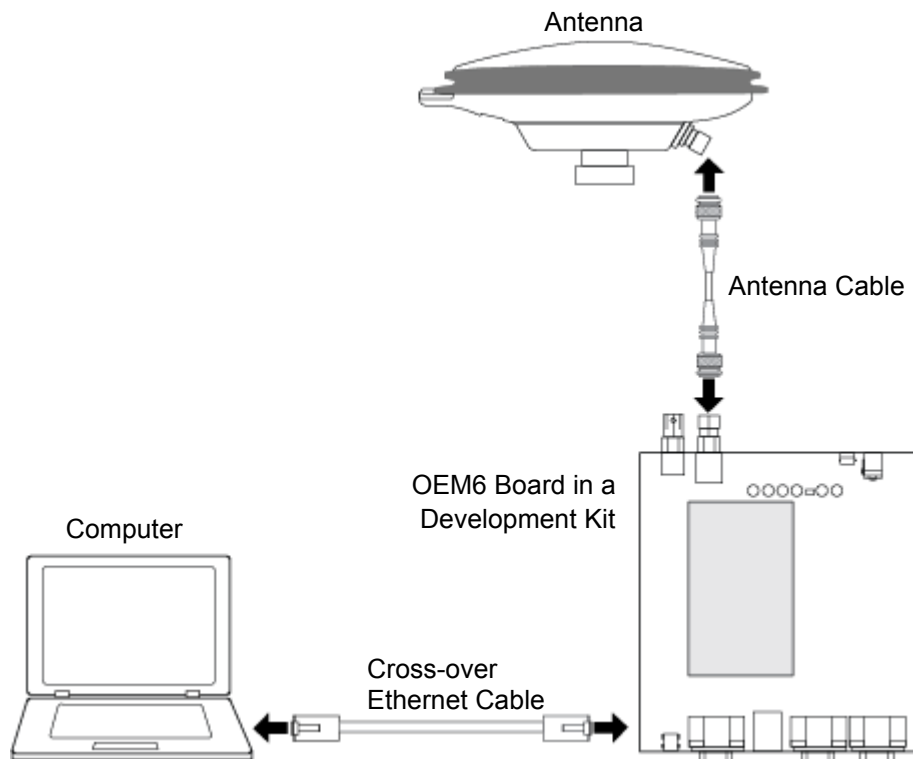
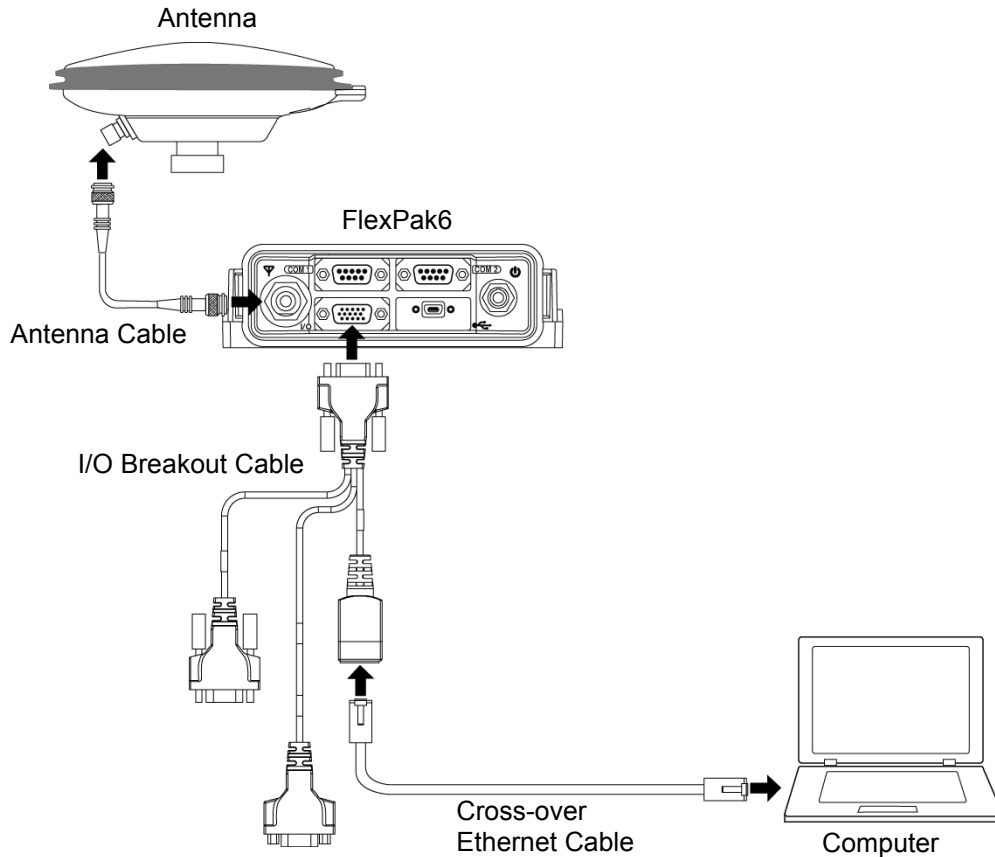

Figure 40: Cross-Over Ethernet Cable Configuration—FlexPak6

6.2.1 Static IP Address Configuration—Receiver

Follow these steps to set up a static IP address on the OEM6 receiver:

1. Connect a computer to the OEM6 receiver using a null modem serial cable or USB cable.
2. Establish a connection to the receiver using either NovAtel Connect or another terminal program such as Windows HyperTerminal. This connection is used to send the commands in this procedure to the receiver.



For information about establishing a connection using NovAtel Connect, refer to the Quick Start Guide for the product or NovAtel Connect Help.

3. Enable the Ethernet port on the receiver by entering:

```
ETHCONFIG ETHA AUTO AUTO AUTO AUTO
```
4. Assign the TCP/IP port number used for the connection by entering:

```
ICOMCONFIG ICOM1 TCP :2000
```
5. Assign the receiver IP address, subnet mask and default gateway by entering:

```
IPCONFIG ETHA STATIC 192.168.74.10 255.255.255.0 192.168.74.1
```



The command assigns the following values to the OEM6 receiver:

```
IP address = 192.168.74.10
Subnet mask = 255.255.255.0
Gateway = 192.168.74.1
```

These settings are examples only. The settings appropriate to your system may be different.

6. Save the new Ethernet settings by entering:

```
SAVECONFIG
```

7. Log the IPCONFIG command and confirm the TCP/IP configuration by entering:

```
LOG IPCONFIG ONCE
```

8. Configure your computer with a static IP address.
For a computer using Windows 7, refer to *Section 6.2.2, Static IP Address Configuration—Windows 7* on page 89.

6.2.2 Static IP Address Configuration—Windows 7

Follow these steps to set up a static IP address on a computer:

1. Click Start | Control Panel.
2. Click **Network and Sharing Center**.
3. Click the **Local Area Connection** link.
The Local Area Connection Status window appears.
4. Click the **Properties** button.
The Local Area Connection Properties window appears.
5. Select **Internet Protocol Version 4 (TCP/IPv4)** and then click the **Properties** button.
The Internet Protocol Version 4 (TCP/IPv4) Properties window appears.
6. Click the **Use the Following IP Address** radio button, then enter the IP address, Subnet mask and Default gateway for the Ethernet port on the computer.



Ensure the Ethernet settings used for the computer are compatible with the Ethernet settings on the OEM6 receiver.

For example, the following settings are compatible with the OEM6 receiver settings used in *Section 6.2.1, Static IP Address Configuration—Receiver* on page 88:

```
IP address = 192.168.74.11
Subnet mask = 255.255.255.0
Gateway = 192.168.74.1
```

7. Click the **OK** button.
The Local Area Connection Properties window appears.
8. Click the **Close** button.
The Local Area Connection Status window appears.
9. Click the **Close** button.
10. Proceed to *Section 6.2.3, Confirming Ethernet Setup* on page 90.

6.2.3 Confirming Ethernet Setup

1. Connect the computer to the OEM6 receiver using an Ethernet cross-over cable. See *Figure 39, Cross-Over Ethernet Cable Configuration—OEM628 and OEM638* on page 87 or *Figure 40, Cross-Over Ethernet Cable Configuration—FlexPak6* on page 88.
2. Connect to the receiver using NovAtel Connect or any third party terminal program that supports TCP/IP connections. Use the static IP address and port number assigned to the OEM6 receiver in *Section 6.2.1, Static IP Address Configuration—Receiver* on page 88.

The figure below shows the New Connection window in NovAtel Connect with the example Ethernet settings used in *Section 6.2.1, Static IP Address Configuration—Receiver* on page 88.

The screenshot shows a 'New Connection' dialog box. The 'Name' field is 'OEM6Receiver'. Under 'Device Type', the 'Type' dropdown is set to 'Network'. Under 'Network Settings', the 'Device Type' dropdown is 'OEM6', the 'IP Address' field is '192.168.74.10', the 'Port' field is '2000', and the 'Protocol' dropdown is 'TCP'. There is a 'Windows Option' button and 'Ok' and 'Cancel' buttons at the bottom.



For information about establishing a connection using NovAtel Connect, refer to the Quick Start Guide for the product or NovAtel Connect Help.

6.3 Dynamic IP Address Configuration

For this configuration, a direct connection is made from the OEM6 receiver to a Dynamic Host Communication Protocol (DHCP) network and into a computer. The DHCP server automatically assigns an IP addresses to the OEM6 receiver, based on its predetermined available IP addresses. Use this configuration in a bench test environment to confirm Ethernet functionality.

Figure 41, Dynamic IP Address Configuration through a DHCP Server—OEM628 and OEM638 on page 91 and Figure 42, Dynamic IP Address Configuration through a DHCP Server—FlexPak6 on page 92 show the connections when an OEM6 receiver uses a dynamic IP address configuration.

Figure 41: Dynamic IP Address Configuration through a DHCP Server—OEM628 and OEM638

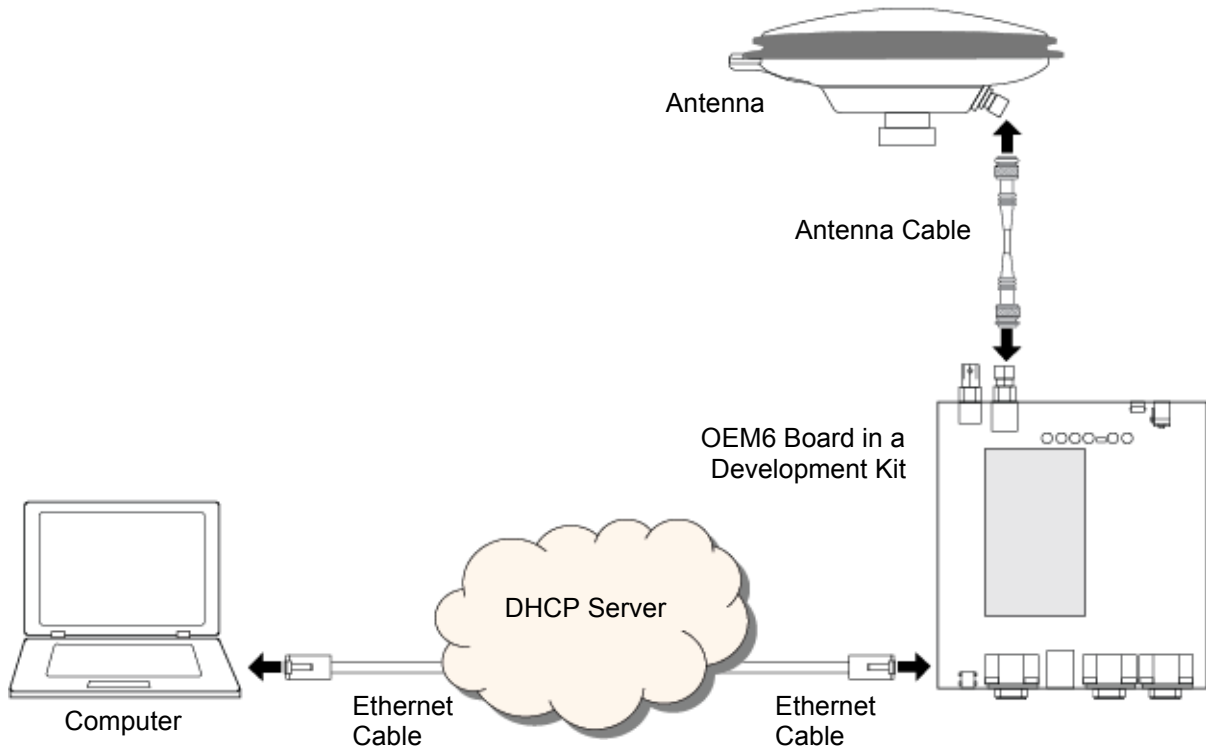
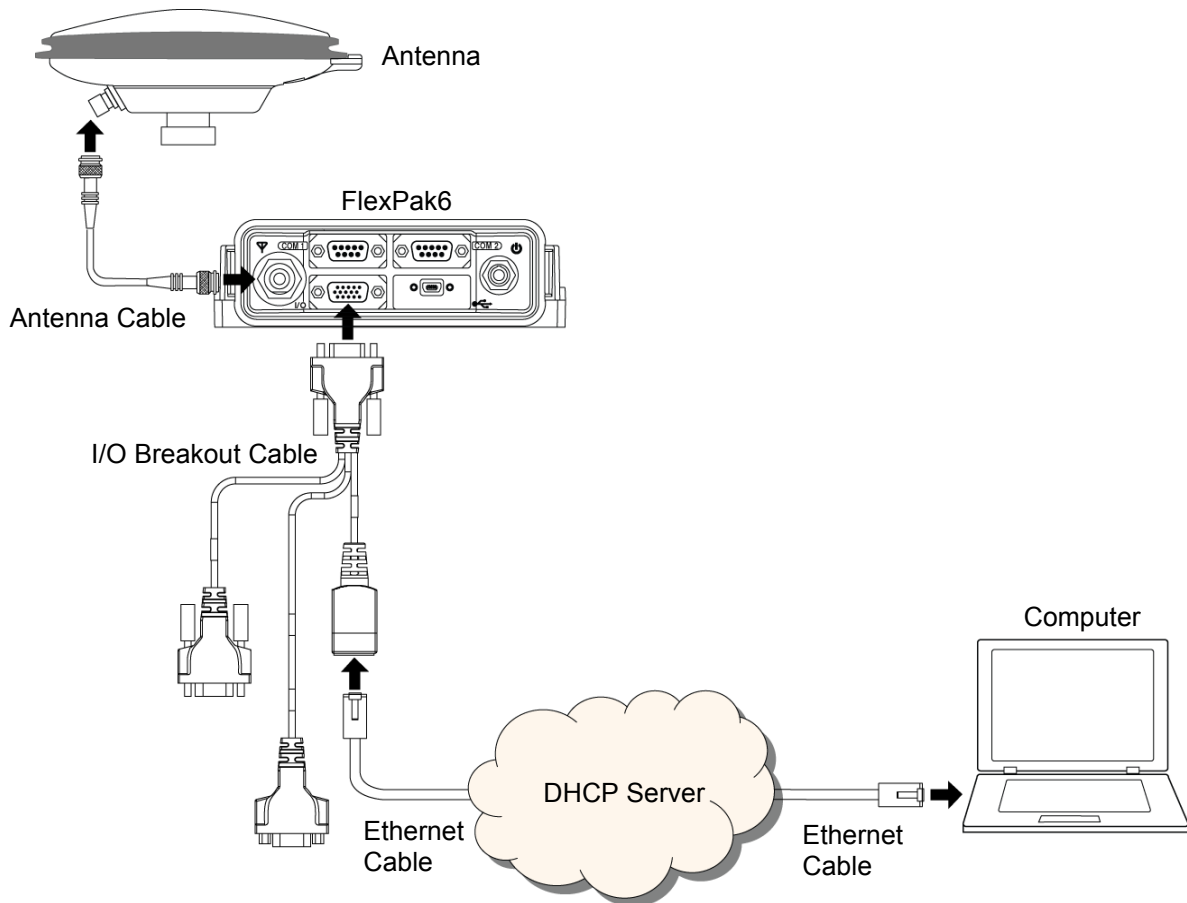

Figure 42: Dynamic IP Address Configuration through a DHCP Server—FlexPak6



To set up a dynamic IP address configuration, follow these steps:

1. Connect a computer to the OEM6 receiver using a null modem serial cable or USB cable.
2. Establish a connection to the receiver using either NovAtel Connect or another terminal program such as Windows HyperTerminal. This connection is used to send the commands in this procedure to the receiver.



For information about establishing a connection using NovAtel Connect, refer to the Quick Start Guide for the product or NovAtel Connect Help.

3. Enable the Ethernet port by entering:

```
ETHCONFIG ETHA AUTO AUTO AUTO AUTO
```

4. Obtain the IP address assigned to the OEM6 receiver by the DHCP server.

```
LOG IPSTATUS ONCE
```



Make a note of the IP address returned with this log. This value is used later in this procedure.

5. Confirm that DHCP is enabled. by entering:

```
LOG IPCONFIG ONCE
```

- Assign the TCP/IP port number by entering:

```
ICOMCONFIG ICOM1 TCP :2000
```

- Confirm the port number assigned to ICOM1 by entering:

```
LOG ICOMCONFIG ONCE
```

- Connect to the receiver using NovAtel Connect or any third party terminal program that supports TCP/IP connections. Use the IP address obtained from the IPSTATUS log in Step 4 and port number assigned in Step 6.

The figure below shows the New Connection window in NovAtel Connect with the Ethernet settings from Step 4.

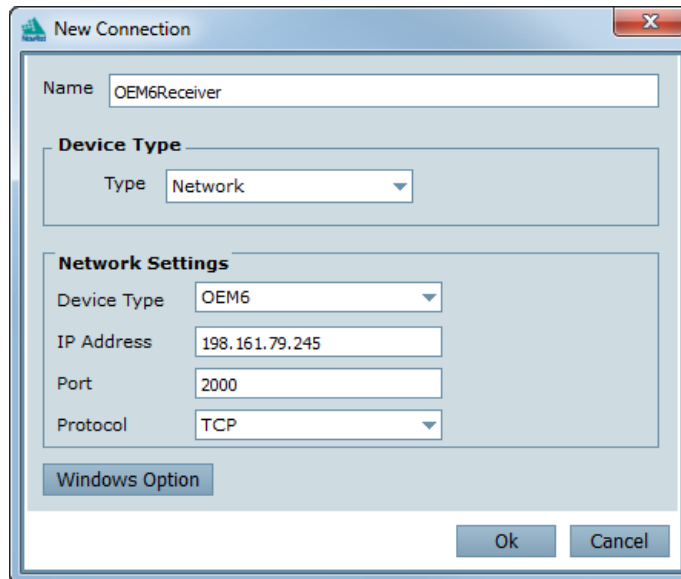

For information about establishing a connection using NovAtel Connect, refer to the Quick Start Guide for the product or NovAtel Connect Help.

6.4 Base/Rover Configuration through Ethernet Connectivity

You can use an Ethernet connection to provide communication between a base and rover receiver.

Figure 43, Base/Rover Ethernet Setup—OEM628 and OEM638 on page 94 and Figure 44, Base/Rover Ethernet Setup—FlexPak6 on page 94 show the connections when a base and rover OEM6 receiver are connected using Ethernet.

Figure 43: Base/Rover Ethernet Setup—OEM628 and OEM638

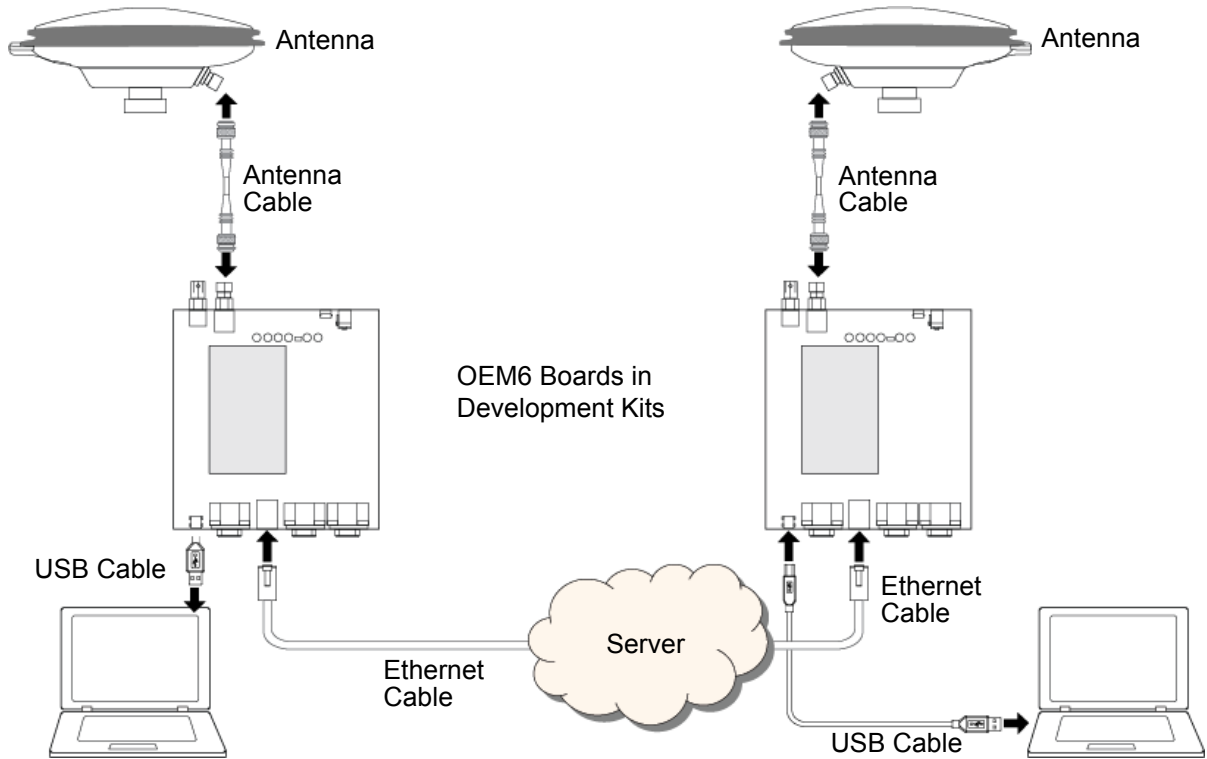
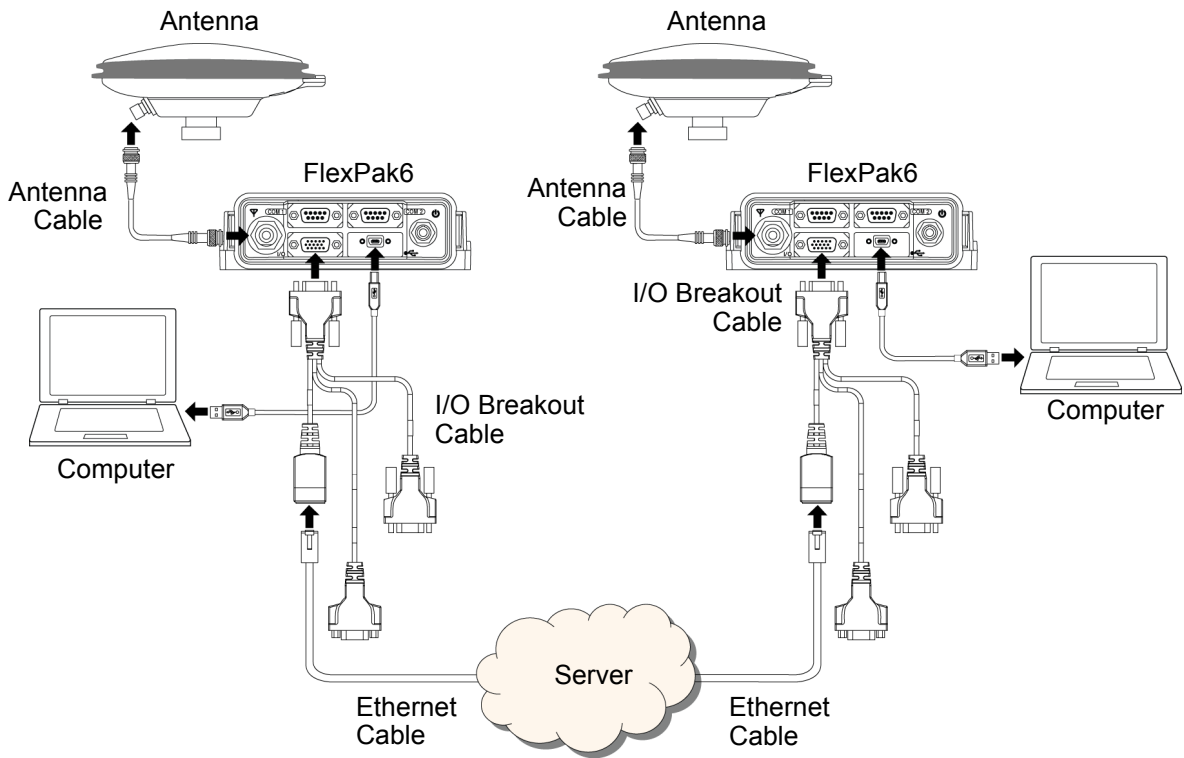

Figure 44: Base/Rover Ethernet Setup—FlexPak6



1. Connect your computer to both OEM6 receivers using null modem serial cables or USB cables.

- Establish a connection to the receiver using either NovAtel Connect or another terminal program such as Windows HyperTerminal. This connection is used to send the commands in this procedure to the receivers.



For information about establishing a connection using NovAtel Connect, refer to the Quick Start Guide for the product or NovAtel Connect Help.

- Connect the power cables to both of the OEM6 receivers and apply power to the receivers.
- Connect the Ethernet cables to the Ethernet ports on both OEM6 receivers.
- Establish an Ethernet connection, either static or dynamic configurations. Refer to *Section 6.2, Static IP Address Configuration* on page 87 or *Section 6.3, Dynamic IP Address Configuration* on page 91 for more information.
- Send the following commands to each receiver either through serial or USB ports:

Base:

```
FIX POSITION <lat> <long> <height>
INTERFACEMODE ICOM1 NONE RTCA off
LOG ICOM1 RTCAOBS2 ONTIME 1
LOG ICOM1 RTCAREF ONTIME 10
LOG ICOM1 RTCA1 ONTIME 5
SAVECONFIG
```

Rover:

```
ICOMCONFIG ICOM1 TCP <base ip address>:<base port #>
INTERFACEMODE ICOM1 RTCA NONE OFF
LOG BESTPOSA ONTIME 1 (optional)
SAVECONFIG
```

Use the BESTPOS log to confirm that the OEM6 rover is in RTK mode.

6.5 Large COM Port Data Throughput

For high data rate Ethernet logging using TCP/IP, disable Windows Delayed Ack Algorithm (DAA) for complete data logging. If you do not disable DAA, there will be data gaps due to the Windows Ethernet buffer.



If done incorrectly, changing the Windows Registry may impair the operation of the computer. Editing the Windows Registry is for advanced Microsoft Windows users only. NovAtel Inc. is not able to provide any technical support for any actions taken regarding information found in Microsoft's Knowledge Base.

Windows XP (SP3) and Windows Server 2003:

<http://support.microsoft.com/kb/328890>

<http://support.microsoft.com/kb/815230>

6.6 NTRIP Configuration

Network Transport of RTCM via Internet Protocol (NTRIP) is an application protocol used to stream GNSS differential correction data over the internet.

An OEM6 receiver can be configured as either an NTRIP server or an NTRIP client. For more information about NovAtel's NTRIP, refer to www.novatel.com/products/firmware-options/ntrip/.

Figure 45: NTRIP System

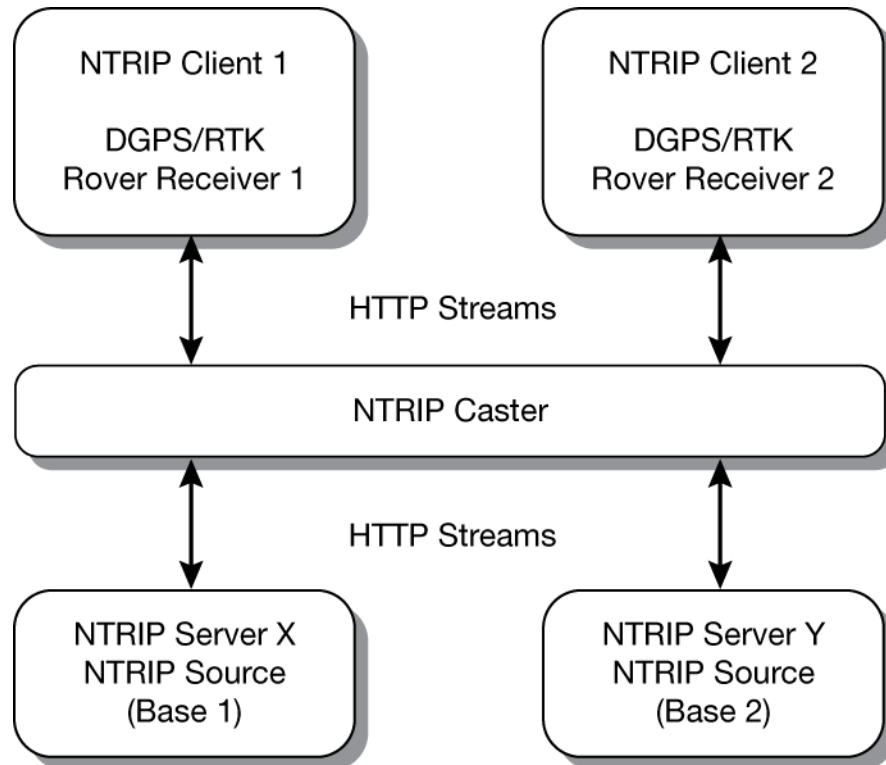

The NTRIP caster is an HTTP internet service that acts as a communication medium between NTRIP servers and NTRIP clients. The NTRIP caster is provided by third party sources. For a full list of NTRIP casters, refer to the following link: <http://www.rtcn-ntrip.org/home>.

The following procedure describes how to configure a NovAtel base and a NovAtel rover through a third party NTRIP caster. This configuration is recommended for optimal RTK performance.

1. Establish a connection to the receiver using either NovAtel Connect or another terminal program such as Windows HyperTerminal. This connection is used to send the commands in this procedure to the receiver.



For information about establishing a connection using NovAtel Connect, refer to the Quick Start Guide for the product or NovAtel Connect Help.

2. Connect the Ethernet cable to the Ethernet ports on both OEM6 receivers. For this setup, use a cross-over Ethernet cable.
3. Establish a static or dynamic Ethernet connection.
For information about creating the connection, refer to *Section 6.2, Static IP Address Configuration* on page 87 or *Section 6.3, Dynamic IP Address Configuration* on page 91.

4. Use the following commands to enable the base receiver as an NTRIP Server:

```
NTRIPCONFIG NCOM1 SERVER V2 <endpoint> <mountpoint> <username>
<password> ETHA
INTERFACEMODE NCOM1 NONE RTCA OFF
FIX POSITION <lat> <long> <height>
LOG NCOM1 RTCAOBS2 ONTIME 1
LOG NCOM1 RTCAREF ONTIME 10
LOG NCOM1 RTCA1 ONTIME 1
SAVECONFIG
```

5. Use the following commands to enable the rover receiver as an NTRIP Client:

```
ETHCONFIG ETHA AUTO AUTO AUTO AUTO
NTRIPCONFIG NCOM1 CLIENT V1 <endpoint> <mountpoint> <username>
<password > ETHA
```



If using a specific Network RTK system, certain National Marine Electronics Association (NMEA) strings are required to be sent from the rover back to the RTK network. For example, if connected to the VRS mount point, the rover is required to send its position to the network in a standard NMEA GGA message. This is achieved by issuing the following commands: `LOG NCOMx GPGGA ONTIME 5`, until data is received by the caster. For more information about Network RTK options and properties, refer to the application note [APN-041 Network RTK](#).

The following is an NTRIP Client configuration example without the use of a Network RTK system:

```
INTERFACEMODE NCOM1 RTCA NONE OFF
RTKSOURCE AUTO ANY
PSRDIFFSOURCE AUTO ANY
LOG BESTPOS ONTIME 1 (optional)
SAVECONFIG
```



Refer to the `NTRIPCONFIG` command in the [OEM6 Family Firmware Reference Manual](#) (OM-20000129) for further command details.

There are simple ways to diagnose and resolve problems. In many cases, the issue can be resolved within a few minutes, avoiding the inconvenience and loss of productivity that results from having to return the receiver for repair. This chapter discusses troubleshooting issues and includes cross-references to other sections of the manual that may help resolve problems.

If unsure of the symptoms or if the symptoms do not match any of those listed, use the RXSTATUS log to check the receiver status and error words. See *Section 7.1, Examining the RXSTATUS Log* on page 99.

Try to resolve the problem using the troubleshooting guide in *Table 11, Troubleshooting Based on Symptoms* on page 98, then try our Knowledge Base at www.novatel.com/support/. If you are still not able to resolve the problem, contact *Customer Support* on page 18.

Table 11: Troubleshooting Based on Symptoms

Symptom	Related Section
The receiver is not properly powered	Check and replace a faulty power cable See <i>Section 2.4, Power Supply Requirements</i> on page 31 for the OEM6 cards or <i>Section 3.3.3, FlexPak6 and FlexPak6D Alternative Power Source</i> on page 47
The receiver cannot establish communication	Check and replace faulty serial cables and ports. See <i>Section 4.10.2, CAN Bus (not available on the FlexPak6D)</i> on page 74 and <i>Section 5.6, Status LED</i> on page 84. Refer also to the COMCONFIG log in the OEM6 Family Firmware Reference Manual (OM-20000129)
The receiver is not tracking satellites	Ensure that you have an unobstructed view of the sky from horizon to horizon. Check the RXSTATUS error states. See <i>Section 7.1, Examining the RXSTATUS Log</i> on page 99. If the receiver is in error mode, it does not track Check for and replace a faulty antenna cable. See <i>Section 2.3, Selecting a GNSS Antenna</i> on page 29, <i>Section 2.3.1, Choosing a Coaxial Cable</i> on page 29, <i>Section 2.3.3, Connecting the Antenna to the Receiver</i> on page 30.
No data is being logged	See <i>Section 4.10.2, CAN Bus (not available on the FlexPak6D)</i> on page 74 and <i>Section 4.1, Communications with the Receiver</i> on page 51
Random data is being output by the receiver or binary data is streaming	Check the baud rate on the receiver and in the communication software. Refer to the SERIALCONFIG log and FRESET command in the OEM6 Family Firmware Reference Manual (OM-20000129). See also <i>Section 4.10.2, CAN Bus (not available on the FlexPak6D)</i> on page 74
A command is not accepted by the receiver	Check for correct spelling and command syntax. See <i>Section 4.1, Communications with the Receiver</i> on page 51 and refer to the FRESET command in the OEM6 Family Firmware Reference Manual (OM-20000129)
Differential mode is not working properly	See <i>Section 4.3, Transmitting and Receiving Corrections</i> on page 55 and refer to the COMCONFIG log in the OEM6 Family Firmware Reference Manual (OM-20000129)
There appears to be a problem with the receiver's memory	Refer to the NVMRESTORE command in the OEM6 Family Firmware Reference Manual (OM-20000129)

Symptom	Related Section
An environmental or memory failure. The receiver temperature is out of acceptable range or the internal thermometer is not working	See the ENVIRONMENTAL sections in the tables of all Appendices specific to the product. Move the receiver to within an acceptable temperature range
Overload and overrun problems. Either the CPU or port buffers are overloaded	Reduce the amount of logging or increase the baud rate. See also <i>Table 4, OEM6 Card Default Serial Port Configurations</i> on page 39
The receiver is indicating that an invalid authorization code has been used	Refer to the VERSION or VALIDMODELS logs and the MODEL or AUTH commands in the OEM6 Family Firmware Reference Manual (OM-20000129)
The receiver is being affected by jamming	Move the receiver away from any possible jamming sources
The receiver's Automatic Gain Control (AGC) is not working properly	See <i>Section 2.3.1, Choosing a Coaxial Cable</i> on page 29 and the jamming symptom in this table

7.1 Examining the RXSTATUS Log

The RXSTATUS log provides detailed status information about your receiver and can be used to diagnose problems. Refer to the [OEM6 Family Firmware Reference Manual](#) (OM-20000129) for details on this log and on how to read the receiver error word and status word. *Table 12, Resolving a Receiver Error Word* on page 99, *Table 13, Resolving an Error in the Receiver Status Word* on page 100 and *Table 14, Resolving an Error in the AUX1 Status Word* on page 101 have actions to take when your receiver has an error flag in these words. If you are not able to resolve the condition, contact *Customer Support* on page 18.

Table 12: Resolving a Receiver Error Word

Bit Set	Action to Resolve
0-2	Issue a FRESET command (for bit 1, reload new firmware)
4	Contact <i>Customer Support</i> on page 18
5	Check the VERSION log. The VERSION log will indicate "Invalid authcode". Upgrade the auth-code as described in <i>Section 8.5, Upgrading Using the AUTH Command</i> on page 112
6	Issue a FRESET command
7	See <i>Section 2.4, Power Supply Requirements</i> on page 31
8	Reserved
9	Check temperature ranges in the ENVIRONMENTAL table sections of all Appendices specific to the product
10-12	Possible hardware or environmental condition. If you cannot resolve the problem, contact <i>Customer Support</i> on page 18
13-14	Reserved
15	Issue a FRESET command and power cycle the unit. If the bit is still present, contact <i>Customer Support</i>

Bit Set	Action to Resolve
16	Monitor CPU idle time. Reduce number of logs or the rate of data logging
17	Ensure that the version log is consistent with the hardware
20	SoftLoad is in progress. See <i>Section 8.4, Updating Using SoftLoad Commands</i> on page 106
21	You may be exceeding the receiver's velocity limit. If so, reduce velocity. This error can only be cleared by resetting the receiver
22	Reload firmware using WinLoad or the SoftLoad commands
31	Possible hardware failure. Contact <i>Customer Support</i> on page 18

Table 13: Resolving an Error in the Receiver Status Word

Bit Set	Action to Resolve
0	Check the Error Word in the RXSTATUS log. See also <i>Table 12, Resolving a Receiver Error Word</i> on page 99
1	Check temperature ranges in the ENVIRONMENTAL table sections of Technical Specifications appendices
2	See <i>Section 2.4, Power Supply Requirements</i> on page 31
3	See <i>Section 2.3, Selecting a GNSS Antenna</i> on page 29, <i>Section 2.3.1, Choosing a Coaxial Cable</i> on page 29, <i>Section 2.3.3, Connecting the Antenna to the Receiver</i> on page 30, <i>Section 4.10.6, Antenna LNA Power</i> on page 77
4	
5	
6	
7	Check the CPU idle time. Check for unnecessary logging. Check for simultaneous use of functionality, for example, API and RTK
8	See <i>Table 9, Serial Ports Supported</i> on page 52
9	
10	
11	
15-17	Reserved
18	When the receiver has tracked GNSS satellites long enough for a valid almanac to be received, this bit will be set to 0.
19	None. This bit only indicates if the receiver has calculated a position.
20	None. This bit is a status bit indicating if the receiver's position has been manually fixed and does not represent a problem. Refer also to the FIX command in the OEM6 Family Firmware Reference Manual (OM-20000129)
21	None. This bit indicates if clock steering has been manually disabled. Refer also to the FRESET command in the OEM6 Family Firmware Reference Manual (OM-20000129)

Bit Set	Action to Resolve
22	None. This bit only indicates if the clock model is valid. Refer also to the <code>FRESET</code> command in the OEM6 Family Firmware Reference Manual (OM-20000129)
23	None. This bit indicates if the phase-lock-loop is locked when using an external oscillator. Refer also to the <code>FRESET</code> command in the OEM6 Family Firmware Reference Manual (OM-20000129)
24	Check the CPU idle time. Check for unnecessary logging. Check for simultaneous use of functionality, for example, API and RTK
29	None. This bit indicates if any bits in the auxiliary 3 status word are set. The auxiliary 3 word provides status information and does not contain any new information on problems. Refer also to the <code>FRESET</code> command in the OEM6 Family Firmware Reference Manual (OM-20000129)
30	None. This bit indicates if any bits in the auxiliary 2 status word are set. The auxiliary 2 word provides status information and does not contain any new information on problems. Refer also to the <code>FRESET</code> command in the OEM6 Family Firmware Reference Manual (OM-20000129)
31	None. This bit indicates if any bits in the auxiliary 1 status word are set. The auxiliary 1 word provides status information and does not contain any new information on problems. Refer also to the <code>FRESET</code> command in the OEM6 Family Firmware Reference Manual (OM-20000129)

7.2 Examining the AUX1 Status Word

Table 14, *Resolving an Error in the AUX1 Status Word* on page 101 provides actions to take when your receiver has an error flag in the AUX1 status word.

Table 14: Resolving an Error in the AUX1 Status Word

Bit Set	Action to Resolve
0-2	(Reserved bits)
3	None. This bit indicates that Position Averaging is ON
4-6	(Reserved bits)
7	Connect the receiver via USB
8-10	Reduce the amount of logging on the USB ports
11-13	(Reserved bits)
14-17	AGC error on RF1 through RF4 respectively. To resolve, ensure the antenna cable is connected and signal input level is within specification
18	Connect the receiver via Ethernet. See <i>Section 4.10.7, Ethernet</i> on page 77
19-21	Reduce the amount of logging on the Ethernet ports
22-24	Reduce the amount of logging on the NTRIP ports
25-27	Reduce the amount of logging on the Virtual COM ports
28-31	(Reserved bits)

Download the most recent versions of the NovAtel firmware and receiver software from the Downloads section of www.novatel.com/support/search/.

OEM6 Firmware and Software



Refer to *Section 8.3.1, Transferring Firmware Files* on page 104 for descriptions of the Update and OEM versions.

NovAtel Connect PC Utilities Software Bundle

Bundled PC Utilities software includes:

- NovAtel Connect (a GUI interface)
- Connection Import (imports connection profiles)
- Convert (converts receiver data logs into different formats)
- USB Drivers and Window Signing



The NovAtel Connect PC Utilities bundle can be download from the Downloads section of www.novatel.com/support/search/.

Firmware and Software included

- Firmware *.shex file
- WinLoad software utility



WinLoad and SoftLoad instructions follow.

8.1 Firmware Updates and Model Upgrades

A local NovAtel dealer can provide all the information needed to upgrade or update a receiver. Refer to www.novatel.com/where-to-buy for contact information or contact sales@novatel.com or support@novatel.com directly.

8.1.1 Firmware Updates

Firmware updates are firmware releases that include fixes and enhancements to the receiver functionality. Firmware updates are released occasionally on the NovAtel web site as they become available. Firmware upgrades can be performed using the WinLoad utility, SoftLoad commands or with a custom loader application. Contact NovAtel Customer Support (support@novatel.com) for details on custom loader requirements.

8.1.2 Model Upgrades

Model upgrades enable purchased receiver features.

Contact a local NovAtel dealer to assist in selecting the upgrade options that best suit your GNSS needs at www.novatel.com/where-to-buy. Contact NovAtel Customer Support www.novatel.com/support or NovAtel.Sales to request a temporary upgrade authorization code for trial purposes.

Model upgrades can be applied to the receiver with an authorization code and the AUTH command without returning the receiver to the dealer.

8.2 Authorization Code

An authorization code, commonly known as an auth-code, is required to upgrade an OEM6 family receiver. Auth-codes are obtained by contacting [NovAtel Customer Support](#). Upon contact, NovAtel Customer Support requires:

- the receiver model number
- the receiver serial number
- the receiver firmware version

Enter the `LOG VERSION` command to determine the receiver model, serial number and firmware version.

Example:

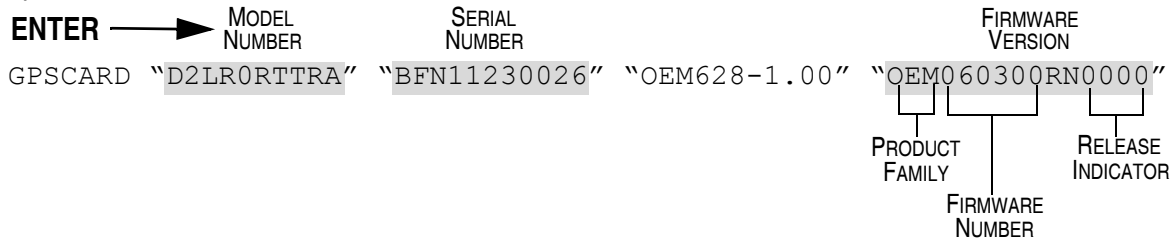

After determining the appropriate model and firmware version the authorization code (auth-code) is issued. The auth-code is required to unlock the features on the new model type.

To upgrade to a new model with the same firmware version, use the `AUTH` command with the issued auth-code, as outlined in *Upgrading Using the AUTH Command* on page 112.

To upgrade to a new model with a new firmware version, the new firmware needs to be loaded into the OEM6 receiver. Refer to *Updating or Upgrading Using the WinLoad Utility* on page 104 for use instructions or to *Updating Using SoftLoad Commands* on page 106.

There are two types of auth-codes:

- Standard auth-codes, which are tied to a model, serial number and firmware version
- Signature auth-codes, which are tied only to a model and serial number

When upgrading to a new version of firmware, the Standard auth-code for the old version of firmware will not work with the new version of firmware. Therefore, a new auth-code is required for each receiver that is upgraded.

However, Signature auth-codes work with any signed firmware image. Therefore, if a receiver has a Signature auth-code for the old version of firmware, that same auth-code will work for the new version of firmware, provided both images are digitally signed by NovAtel.

Signature auth-codes require firmware version OEM060200RN0000 (6.200) or later and boot code version OEM060100RB0000 (6.100) or later.

Signed firmware images are distributed in *.shex files, while unsigned firmware images are distributed in *.hex files.

Temporary auth-codes may be provided by NovAtel for evaluation purposes. Once the trial period has expired, a new auth-code will need to be obtained from NovAtel Customer Support (support@novatel.com).

The new download package includes a signed firmware file type that uses an extension designated as ".shex" (example OEM060200RN0000.shex), as well as the latest WinLoad utility and What's New file containing firmware update change details.



Prior to firmware version OEM060200RN0000, authorization codes depended on the software model, the firmware version and the serial number of the receiver. The authorization code changed if any of the three items changed. This is no longer the case, they are now no longer dependent on firmware version.

8.3 Updating or Upgrading Using the WinLoad Utility

WinLoad is the simplest and most common way to update or upgrade an OEM6 receiver.

8.3.1 Transferring Firmware Files

To proceed with an update or possibly an upgrade, obtain the latest version of firmware by downloading the (OEM Version) for your product from www.novatel.com/support/firmware-downloads/.

Format of Firmware Files

All of the firmware available on the downloads website are packaged in .zip files with the following names:

- OEMXXXX.zip for firmware to be installed on OEM615, OEM617, OEM617D, FlexPak6, FlexPak6D or OEM628 receivers
- OMPXXXX.zip for firmware to be installed on OEM638 receiver

NovAtel Customer Service may generate and provide the required authorization code. Authorization codes are obtained by contacting support@novatel.com or at www.novatel.com/Support/.

For convenience, unzip the update file to a GNSS sub-directory (for example, C:\GNSS\LOADER). If the firmware update file is password protected, NovAtel Customer Support provides the required password.

The zip archive includes the following files:

winload.exe	WinLoad utility program
howto.txt	Instructions on how to use the WinLoad utility
whatsnew.rtf	Information on the changes made in the firmware since the last revision
x..x.shex	Firmware version upgrade file, where x..x defines the product name and release (e.g., OEM060400RN0000.shex)

NovAtel Software License Agreement.rtf License agreement for the firmware.

The files are extracted to unzip/program files/NovAtel Inc/x.xxx Full Update Disk, where x.xxx is the firmware version.



NovAtel has an online video tutorial that explains firmware uploading at: www.novatel.com/support/videos.

8.3.2 Using the WinLoad Utility

If opening WinLoad for the first time, ensure the file and communications settings are correct.

Open a File to Download

Select File |Open. Navigate to the file to open (*Figure 46, WinLoad's Open Window* on page 104).

Figure 46: WinLoad's Open Window

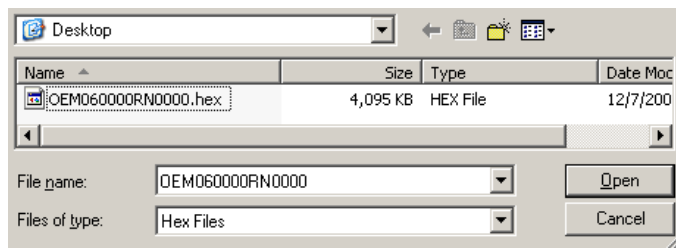

When a file is selected, the *filename* appears in the main WinLoad display area and in the title bar (*Figure 47, Open File in WinLoad* on page 105).

Figure 47: Open File in WinLoad

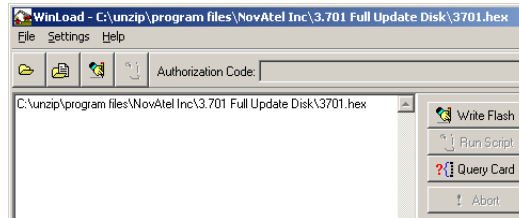

Communications Settings

To set the communications port and baud rate, select Settings | COM Settings. Choose the computer port to use from the Com Port drop down list and the baud rate from the Download Baudrate drop down list. Set the baud rate as high as possible (the default of 115200 is preferred if a higher baud rate is not available).

Figure 48: COM Port Setup

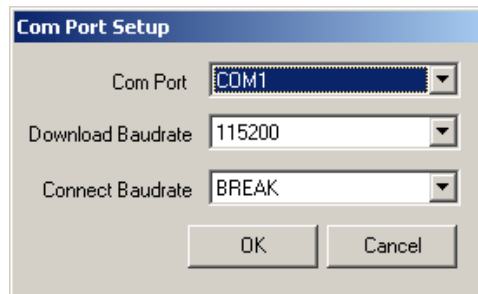

Downloading Firmware

1. Select the file to download according to *Open a File to Download* on page 104.
2. Ensure the file path and name are displayed in main display area (see *Figure 47, Open File in WinLoad* on page 105).
3. Click **Write Flash** to download the firmware.
4. When *Searching for card* appears in the main display, power cycle the receiver.

Figure 49: Searching for Card



5. If the Authorization Code window appears, enter the auth-code and click **OK**. See *Section 8.2, Authorization Code* on page 103 for further information about the Authorization Code.

Figure 50: Authorization Code Window

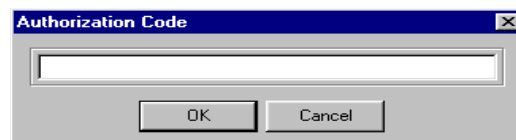

- The receiver finishes the download and then resets. The process is complete when *Done* appears in the main display area.

Figure 51: Upgrade Process Complete

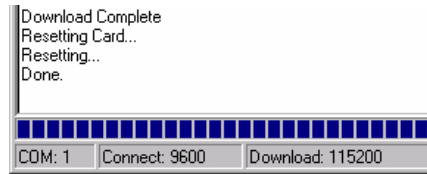

- Close WinLoad.

8.4 Updating Using SoftLoad Commands

Firmware can be updated on a running receiver using a process called SoftLoad. Any available communication ports on the receiver (COM, USB, ICOM, XCOM, etc.) can be used. The SoftLoad process is made up of a set of commands and logs that are used to send new firmware data to a receiver and check the progress of the update. Use SoftLoad if automated loading is desired or if a connection is only possible through USB or Ethernet.

The receiver stops tracking GNSS satellites during the SoftLoad process. Do not attempt to SoftLoad when GNSS satellite tracking on the unit is required. If the unit is connected to the NovAtel Connect utility, only the Console and ASCII Message windows may remain open in the Connect Utility.

8.4.1 SoftLoad Commands and Logs

Refer to the [OEM6 Family Firmware Reference Manual](#) (OM-20000129) for further log and command information.

Command	Description
SOFTLOADRESET	Initiate a new SoftLoad process
SOFTLOADSREC	Send an S-Record to the receiver for the SoftLoad process
SOFTLOADDATA	Send firmware image data to the receiver for the SoftLoad process
SOFTLOADCOMMIT	Complete the SoftLoad process
SOFTLOADSETUP	Send configuration information to the receiver for the SoftLoad process. This command is not required when working with a *.hex or *.shex file
Log	Description
SOFTLOADSTATUS	Provides status updates for the ongoing SoftLoad process

Each command and log can be used in abbreviated ASCII, ASCII or binary format, with the exception of SOFTLOADDATA, which should only be used in binary format.

File Types

Firmware data is stored in *.hex and *.shex files as ASCII data in the form of S-Records, based on the Motorola S-Record format. The *.shex file is the same as the *.hex file but includes a digital signature for the firmware.

8.4.2 Working With S-Records

Each S-Record has a header indicating the type of information contained in the record.

Records beginning with S0, S5 and S7 contain metadata about the firmware image, such as version information and which card types are supported by the firmware image.

Example S0 Record

```
S0~V~OEM060400RN0000
```

Example S5 Records

```
S50000
```

```
S503D9FE25
```

```
S5033158D5A
```

Example S7 Records

```
S70000
```

```
S70500000000FA
```

Records beginning with S3 contain the actual firmware image data. Aside from the header, each pair of characters forms the ASCII representation of a binary byte. The format is as follows:

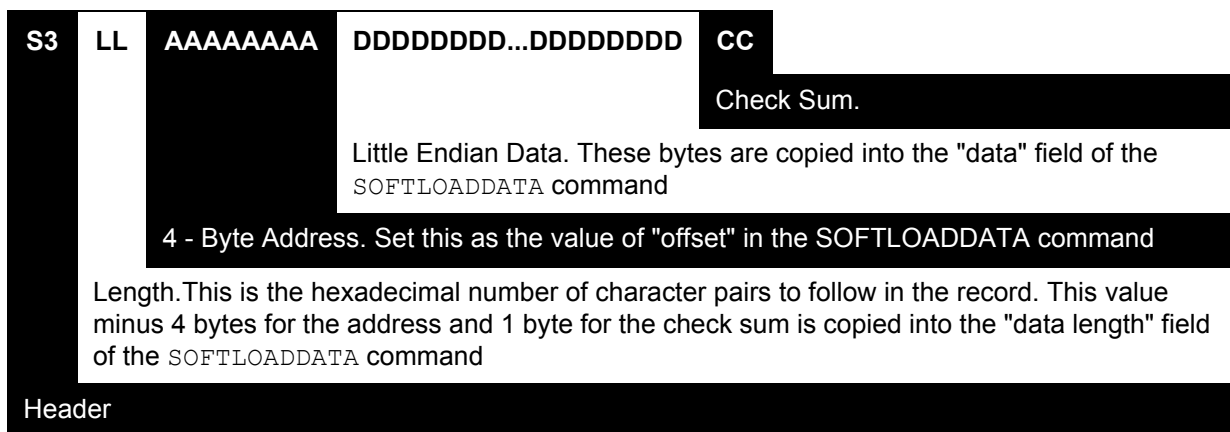

8.4.3 Sending Firmware Data

C++ source code is available to provide example code of processing S-Records and converting them to NovAtel format commands, as well as providing help with the SoftLoad process. Contact [NovAtel Customer Support](#) and ask about the srec2softload utility.

The `SOFTLOADSREC` and `SOFTLOADDATA` commands can be used to send firmware data from *.hex or *.shex files to the receiver.

S0, S5 and S7 S-Records should be sent directly to the receiver using the `SOFTLOADSREC` command, by enclosing the S-Record in quotation marks and issuing the command to the receiver, as follows:

```
SOFTLOADSREC "<S-RECORD>"
```

S3 records can be sent individually to the receiver using the `SOFTLOADSREC` command. Alternatively, the data from an S3 record can be parsed and packaged together with data from other S3 records into a binary `SOFTLOADDATA` command. Packaging data parsed from multiple S3 records into a binary `SOFTLOADDATA` command can result in improved firmware update times as each S3 record contains only a small number of bytes of firmware data. A single `SOFTLOADDATA` command can package up to 4096 bytes of firmware data from multiple S3 records, whereas a single `SOFTLOADSREC` command contains a maximum of 28 bytes of firmware data from a single S3 record.

Multiple S3 records can be packaged into a single `SOFTLOADDATA` command as long as the data from one S3 record follows immediately after the previous record. That is, the address from the current S3 record must equal the address from the previous S3 record plus the data length of the previous S3 record. If the data is not consecutive then the `SOFTLOADDATA` command can be sent with the amount of data it has packaged up to that point. Subsequent data can be packaged in a new `SOFTLOADDATA` command. Within the `SOFTLOADDATA` command, the "offset" field remains the address of the first S3 record and the "data" and "data length" are updated to include the new data. Refer to the [OEM6 Family Firmware Reference Manual \(OM-20000129\)](#) for more information regarding the `SOFTLOADDATA` command.

The *.hex and *.shex file data may contain many gaps and jumps. For example, in many NovAtel *.hex and *.shex files, data for address 0x000_00000 is stored near the very end of the file.

Example Packaging Multiple S3 Records In A SOFTLOADDATA Command

Start a new `SOFTLOADDATA` command

```
S32100407AD48FCA63034B80F5CE0C36507DE3D8DCC0C6C0C00515D74BCACF2F2949E1
```

Address: 0x00407AD4 Num Data Bytes: 0x21 – 0x01 – 0x04 = 0x1C

```
S32100407AF04CCA4985F0F7B081E41D9B7D806C26989AE2D4E4CCBCB47C10FBFD3E43
```

Previous Address + Previous Num Bytes = 0x00407AD4 + 0x1C = 0x00407AF0

Address: 0x00407AF0 Num Data Bytes: 0x1C

Add data to existing `SOFTLOADDATA` command

```
S30D00407B0CDE0400A6374D5BFFC5
```

Previous Address + Previous Num Bytes = 0x00407AF0 + 0x1C = 0x00407B0C

Address: 0x00407B0C Num Data Bytes: 0x0D – 0x01 – 0x04 = 0x08

Add data to existing `SOFTLOADDATA` command

```
S3210000000007F0A7F1F4060000147B4000F49217813C7BB00014493F005C00000009
```

Previous Address + Previous Num Bytes = 0x00407B0C + 0x08 = 0x00407B14

Address: 0x00000000 Num Data Bytes: 0x1C

Requires new `SOFTLOADDATA` command because address does not match previous address + previous number of data bytes. Wait until a response is received from the previous command before sending the new command.

Send existing `SOFTLOADDATA` command, and start a new `SOFTLOADDATA` command

```
S3210000001C80040000E001000030000000082B0100D8060000E4060000C806000063
```

Address: 0x0000001C Num Data Bytes: 0x1C

Previous Address + Previous Num Bytes = 0x00000000 + 0x1C = 0x0000001C

Add data to existing `SOFTLOADDATA` command

The `SOFTLOADDATA` command must be sent as a NovAtel binary format command.

8.4.4 SoftLoad Update Method

This section describes the sequence of commands that are issued to the receiver when updating using a *.hex or *.shex file.



The response for each command must be processed before sending the next command so as to determine if the command was accepted or rejected, and to wait for the receiver to complete the operation. Responses to SoftLoad commands are guaranteed to be output from the receiver within a specific time, which varies by command. Refer to the [OEM6 Family Firmware Reference Manual](#) (OM-20000129) for more information on responses, and the timeout values for SoftLoad commands.

1. Open a connection to any port on the receiver (COM, USB, ICOM or XCOM) with the input and output INTERFACEMODE set to NOVATEL.
2. Request the SOFTLOADSTATUS log using the following command:
LOG SOFTLOADSTATUS ONCHANGED
3. Initialize SoftLoad with a SOFTLOADRESET command. This command stops all tracking on the receiver to ensure sufficient memory is available for the loading process. An RXSTATUSEVENTA log reports a SoftLoad In Progress status.
4. Open the *.hex or *.shex firmware file.
5. Read each line of the *.hex or *.shex firmware file.
 - a. Send S0, S5 and S7 S-Records directly to the receiver using the SOFTLOADSREC command. The S-Record must be enclosed in quotation marks:
SOFTLOADSREC "<S-RECORD>"
Data within S0 records can also be sent to the receiver by converting them to SOFTLOADSETUP commands. Refer to the [OEM6 Family Firmware Reference Manual](#) (OM-20000129) for details on how to convert from S0 S-Records to SOFTLOADSETUP commands.
 - b. S3 S-Records should be parsed and packaged into a SOFTLOADDATA command.
6. Send the SOFTLOADCOMMIT command after all data from the *.hex or *.shex file has been transferred to the receiver. The SOFTLOADSTATUS log reports the status of the loading process. Wait for a SOFTLOADSTATUS log to indicate the status is COMPLETE. The COMPLETE status or an error is guaranteed to be output from the receiver within 300 seconds from the time the SOFTLOADCOMMIT command was received by the receiver.
7. Send the auth code for the newly downloaded image using the AUTH command. This is only required if there is not already a signature auth code on the receiver as signature auth codes are maintained through a SoftLoad update. See *Section 8.2, Authorization Code* on page 103 for details on Auth Codes.
AUTH ADD_DOWNLOAD <AUTH CODE>
8. Reset the receiver using any of the following methods:
 - a. Enter the RESET command
 - b. Enter the FRESET command
 - c. Power-cycle the receiver

Once the receiver resets, the new version of firmware is active.

The SoftLoad process can be safely canceled at any time using the `SOFTLOADRESET` command or by otherwise resetting the receiver. Once the `COMPLETE` status is reported by `SOFTLOADSTATUS`, the new firmware image will be run after the receiver is reset.

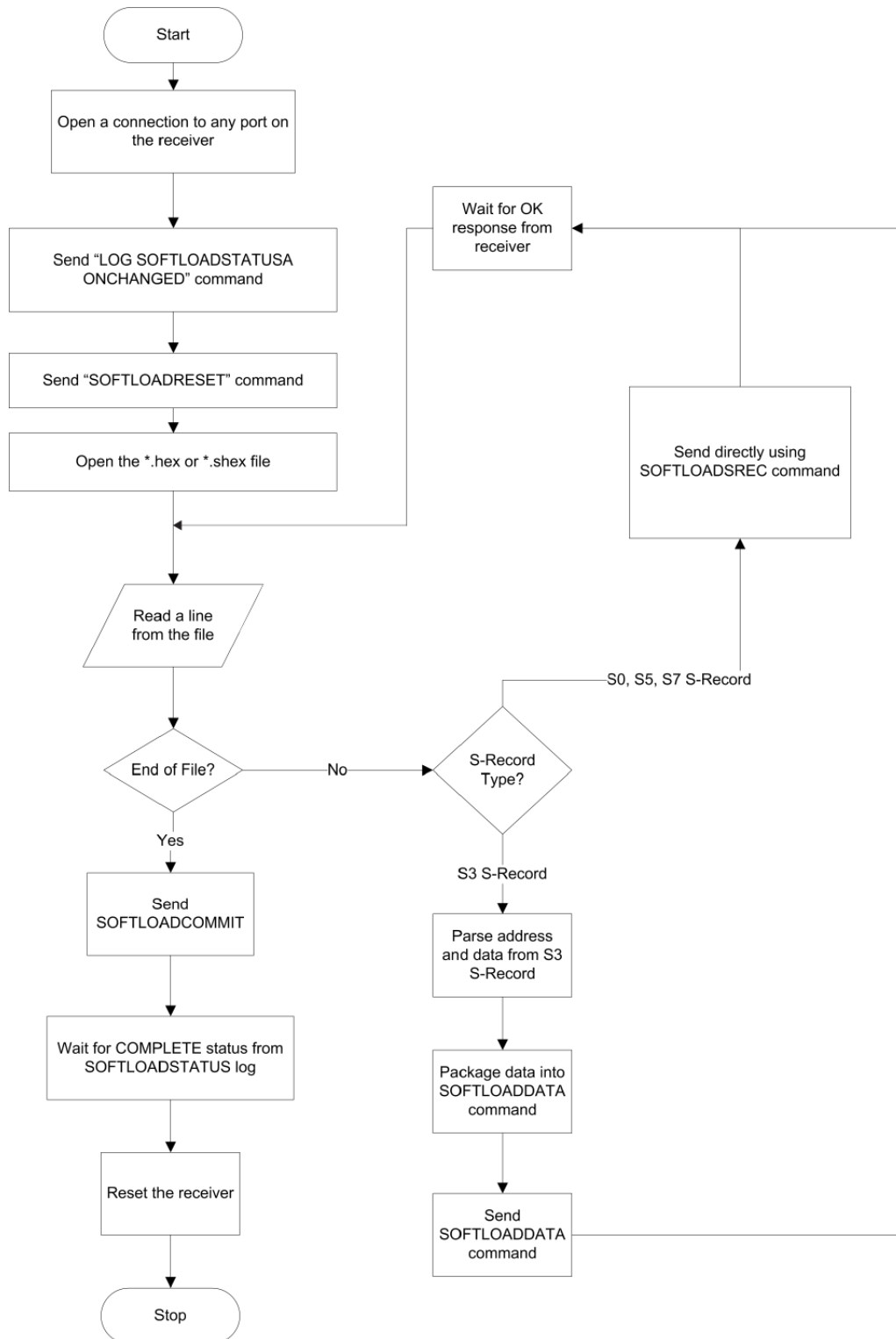

8.4.5 Firmware Update Using FTP or USB Mass Storage Device 638

Select OEM receivers support upload of firmware files via FTP or USB. The `SOFTLOADFILE` command can be used to update the receiver firmware if *.hex or *.shex files have been uploaded via FTP or are available on an attached USB.

The FTP server in the receiver can be accessed using Ethernet or Wi-Fi. Refer to the `IPSERVICE` command in the [OEM6 Family Firmware Reference Manual](#) (OM-20000129) for details. The FTP server allows uploads to the internal flash of the receiver, however the firmware file in internal flash must be copied to the receiver's boot flash device using the `SOFTLOADFILE` command before it becomes the active firmware running on the receiver.

This method of updating firmware is referred to as the SoftLoad Direct method.

8.4.6 SoftLoad Direct Commands and Logs

Refer to the [OEM6 Family Firmware Reference Manual](#) (OM-20000129) for further log and command information.

Command	Description
<code>SOFTLOADFILE</code>	Allows updating using a *.hex or *.shex file that has been uploaded to the receiver via FTP or USB on platforms supporting those interfaces
Log	Description
<code>SOFTLOADSTATUS</code>	Provides status updates for the ongoing SoftLoad process

Each command and log can be used in abbreviated ASCII, ASCII or binary format.

8.4.7 SoftLoad Direct Update Method

1. Open a connection to any port on the receiver (COM, USB, ICOM or XCOM) with the input and output `INTERFACEMODE` set to `NOVATEL`.
2. Request the `SOFTLOADSTATUSA` log using the following command:
`LOG SOFTLOADSTATUSA ONCHANGED`
3. Initiate the firmware update using one of the following commands where <<firmwarefilename.hex>> is the name of the *.hex or *.shex file:
 - a. If using internal flash use this command:
`SOFTLOADFILE INTERNAL_FLASH firmwarefilename.hex`
 - b. If using a USB:
`SOFTLOADFILE USBSTICK firmwarefilename.hex`
4. During the loading process, `SOFTLOADSTATUS` logs report the load status. Wait for the `SOFTLOADSTATUS` to indicate the status is `COMPLETE`.
5. Send the auth code for the newly downloaded image using the `AUTH` command. This is only required if there is not already a signature auth code on the receiver as signature auth codes are maintained through a SoftLoad update. See *Section 8.2, Authorization Code* on page 103 for details on Auth Codes
`AUTH ADD_DOWNLOAD <AUTH CODE>`
6. Reset the receiver using any of the following methods:
 - a. Enter the `RESET` command
 - b. Enter the `FRESET` command
 - c. Power-cycle the receiver
7. Once the receiver resets, the new version of firmware is active.

8.4.8 SoftLoad Errors

It is possible for errors to occur during the SoftLoad update. All command responses should be checked to verify all issued commands were accepted. The SoftLoad status should also be monitored in the SOFTLOADSTATUS log. Any status enum value greater than the ERROR status indicates an error has occurred during the SoftLoad update. In the event of an error, the SoftLoad update should be restarted by issuing a SOFTLOADRESET command or normal operation can be restored by resetting the receiver.

In rare cases after a SoftLoad error, the boot code may not be able to determine which is the latest firmware to be executed. To protect against this, SoftLoad does not erase the previous valid firmware image from flash on the receiver. In such cases, the boot code will execute the old image and raise the "Safe Mode" error (see RXSTATUS log). If that error is detected, simply restart the SoftLoad process to reload the new firmware image and the error will be resolved.

8.5 Upgrading Using the AUTH Command

The AUTH command is used to upgrade to a new OEM6 family model with an authorization code that enables (unlocks) model features. This command only functions with a valid auth-code assigned by [NovAtel Customer Support](#).

The upgrade can be performed directly through the NovAtel Connect command line or from any other communications program.



Refer to *Format of Firmware Files* on page 104 for details on updating versus upgrading.

8.5.1 Upgrade Procedure

1. Power up the OEM6 family receiver and establish communications (refer to the Quick Start Guide included with the product for instructions).
2. Issue the LOG VERSION command to verify the current model, firmware version and serial number (refer to *Section 8.2, Authorization Code* on page 103 for instructions on obtaining).
3. Issue the AUTH command, followed by the auth-code (refer to *Section 8.2, Authorization Code* on page 103 for details on obtaining any auth-code). The syntax is as follows:

```
auth <your auth-code here>
```

where auth is a command that enables model upgrades and auth-code is the upgrade authorization code, expressed as follows:

```
XXXXXX, XXXXXX, XXXXXX, XXXXXX, XXXXXX, MODEL, EXPDATE
```

where:

- Each X character is a case-insensitive ASCII character.
- The MODEL string is a maximum of 15 characters long and represents the model enabled by the auth-code.
- The EXPDATE string is the auth-code's expiry date, in YYMMDD format

Example:

```
auth 7WBMBK, 887CB6, K5J3FH, 5DF5P2, 42PW8G, D1SB0GTT0, 121211
```

When the AUTH command is executed, the OEM6 family receiver reboots. Issuing the LOG VERSION command confirms the new upgrade model type and firmware version number.

If communicating using NovAtel Connect, the communication path must be closed and reopened using the Device menu.

A.1 OEM615 Receiver **615**

PERFORMANCE (Subject to GPS System Characteristics)					
Position Accuracy ^a	Single point	L1 only	1.5 m RMS		
		L1/L2	1.2 m RMS		
	NovAtel CORRECT	SBAS ^b	0.6 m RMS		
		DGPS	0.4 m RMS		
		RTK	1 cm + 1 ppm RMS		
Time to First Fix	Hot: 35 s (Almanac and recent ephemeris saved and approximate position and time entered) Cold: 50 s (No almanac or ephemeris and no approximate position or time)				
Reacquisition	0.5 s L1 (typical) 1.0 s L2 (typical)				
Data Rates	Measurements	up to 50 Hz			
	Position	up to 50 Hz			
Time Accuracy ^{ac}	20 ns RMS				
Velocity Accuracy ^a	0.03 m/s RMS				
Measurement Precision		GPS		GLO	
		Code	Carrier	Code	Carrier
	L1 C/A	4 cm	0.5 mm	8 cm	1.0 mm
	L2 P(Y) ^d	8 cm	1.0 mm	8 cm	1.0 mm
	L2 C ^e	8 cm	0.5 mm	8 cm	1.0 mm
Dynamics	Velocity	515 m/s ^f			

- a. Typical values. All position and velocity RMS values are based on Horizontal position accuracy. Performance specifications are subject to GPS system characteristics, U.S. DOD operational degradation, ionospheric and tropospheric conditions, satellite geometry, baseline length and multipath effects.
- b. GPS-only.
- c. Time accuracy does not include biases due to RF or antenna delay.
- d. L2 P for GLONASS
- e. L2 C/A for GLONASS
- f. In accordance with export licensing.

A.1.1 Physical Description

PHYSICAL	
Size	46 mm x 71 mm x 11 mm
Weight	24 grams
NOVATEL PART NUMBER	
Generic assembly OEM615	01018784
MECHANICAL DRAWINGS	

Figure 52: OEM615 Board Dimensions

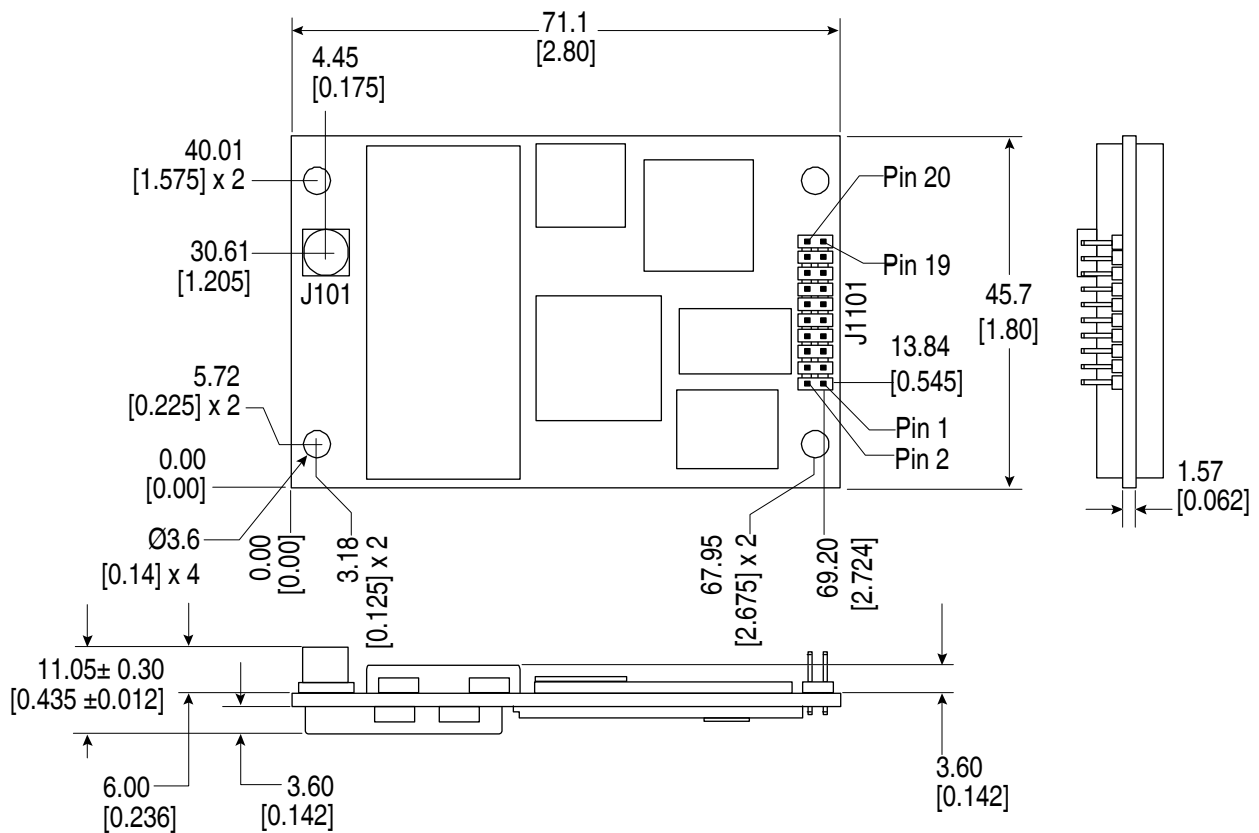

Notes:

1. Dimensions are in millimeters [inches].
2. Connectors:
 - (a) J101: MCX jack receptacle, straight (Johnson P/N 133-3711-202 or SAMTEC P/ N MCX- J-P-H-ST-SMI or equivalent)
 - (b) J1101: 2x10 header, 2 mm pitch (SAMTEC P/ N TMM-110-03-G-D)
3. Mounting holes are symmetrical.

Figure 53: OEM615 Keep-Out Zone

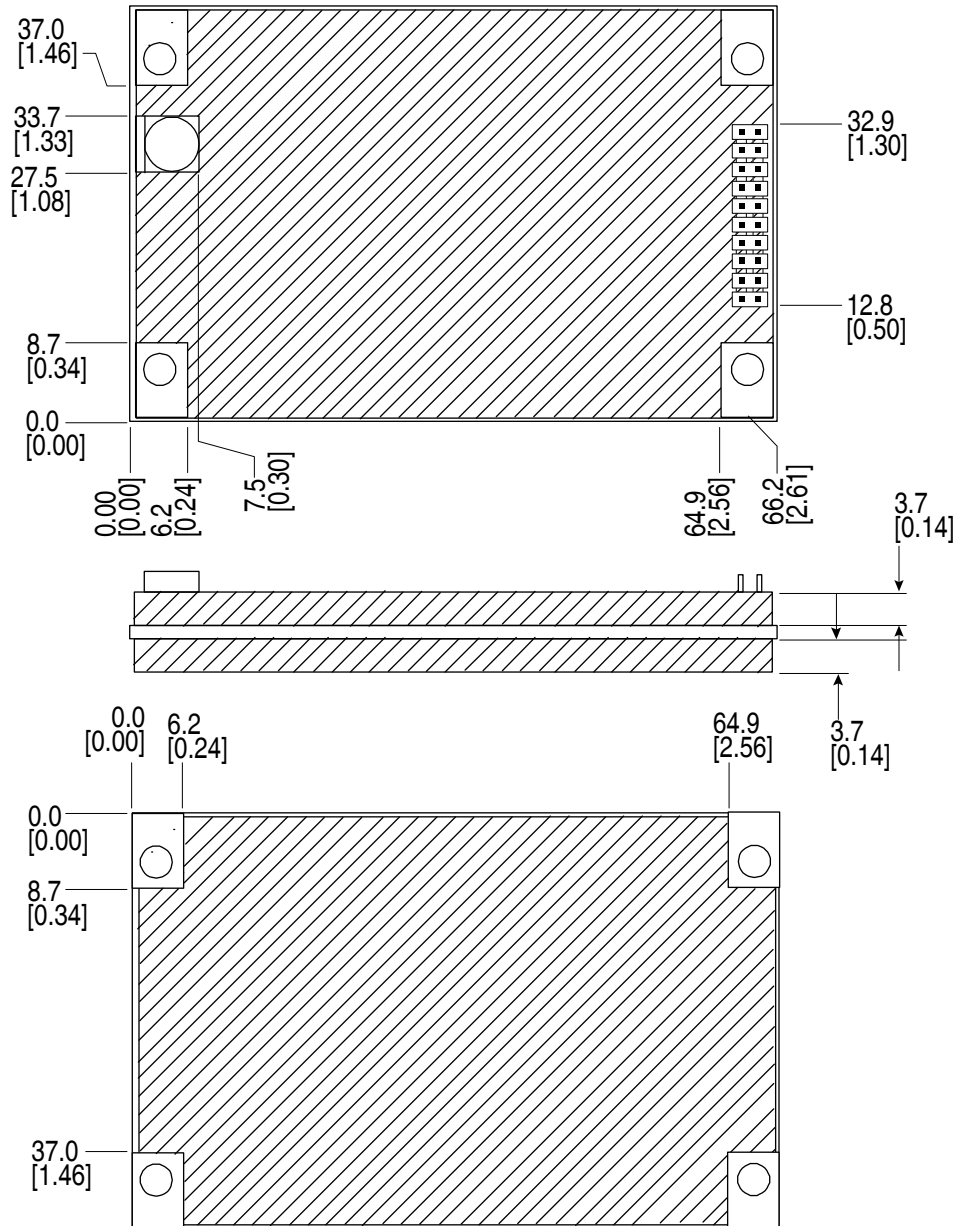

Note:

1. Dimensions are in millimeters [inches].
2. Keep-out areas are intended for NovAtel circuitry.

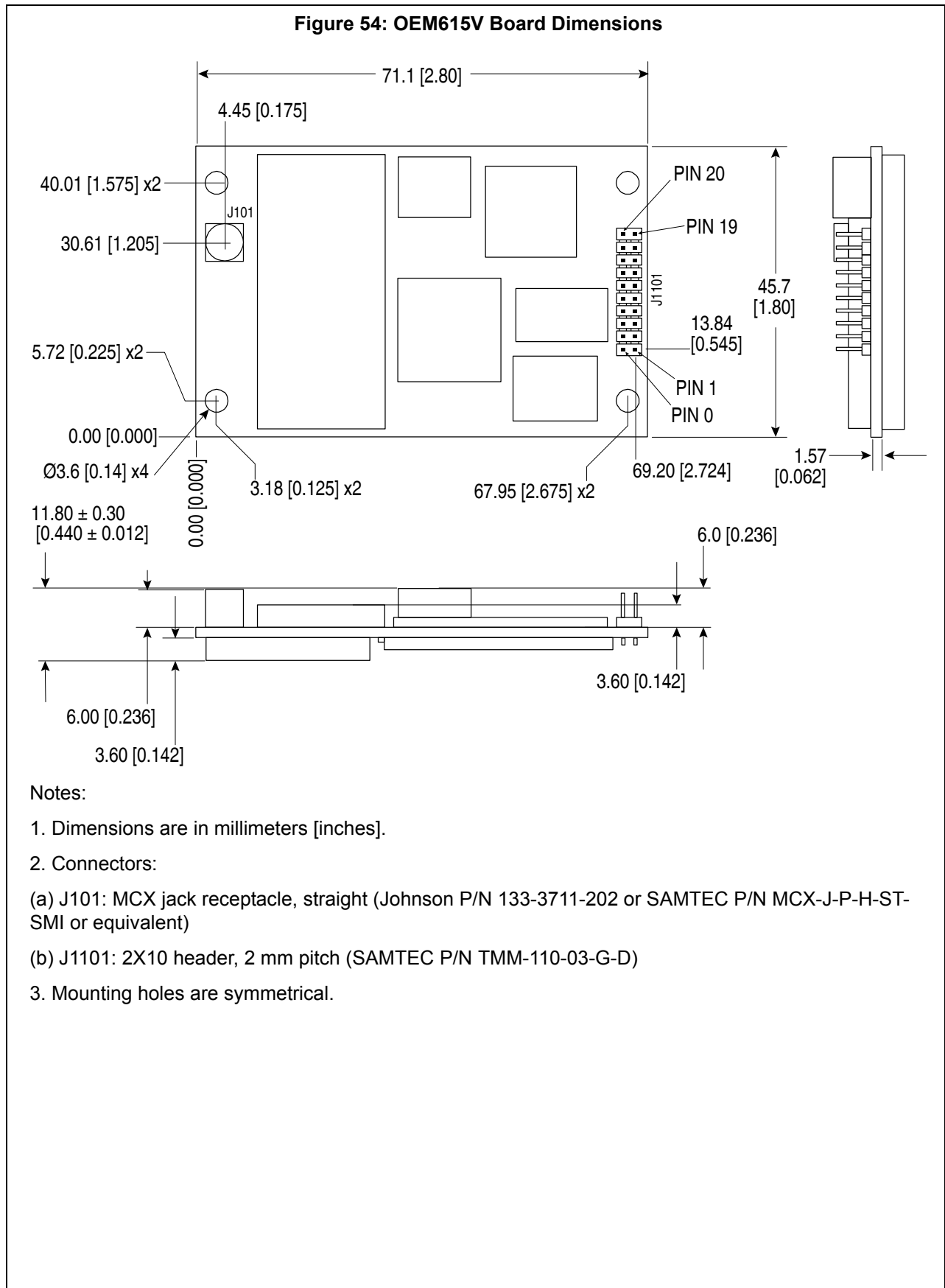
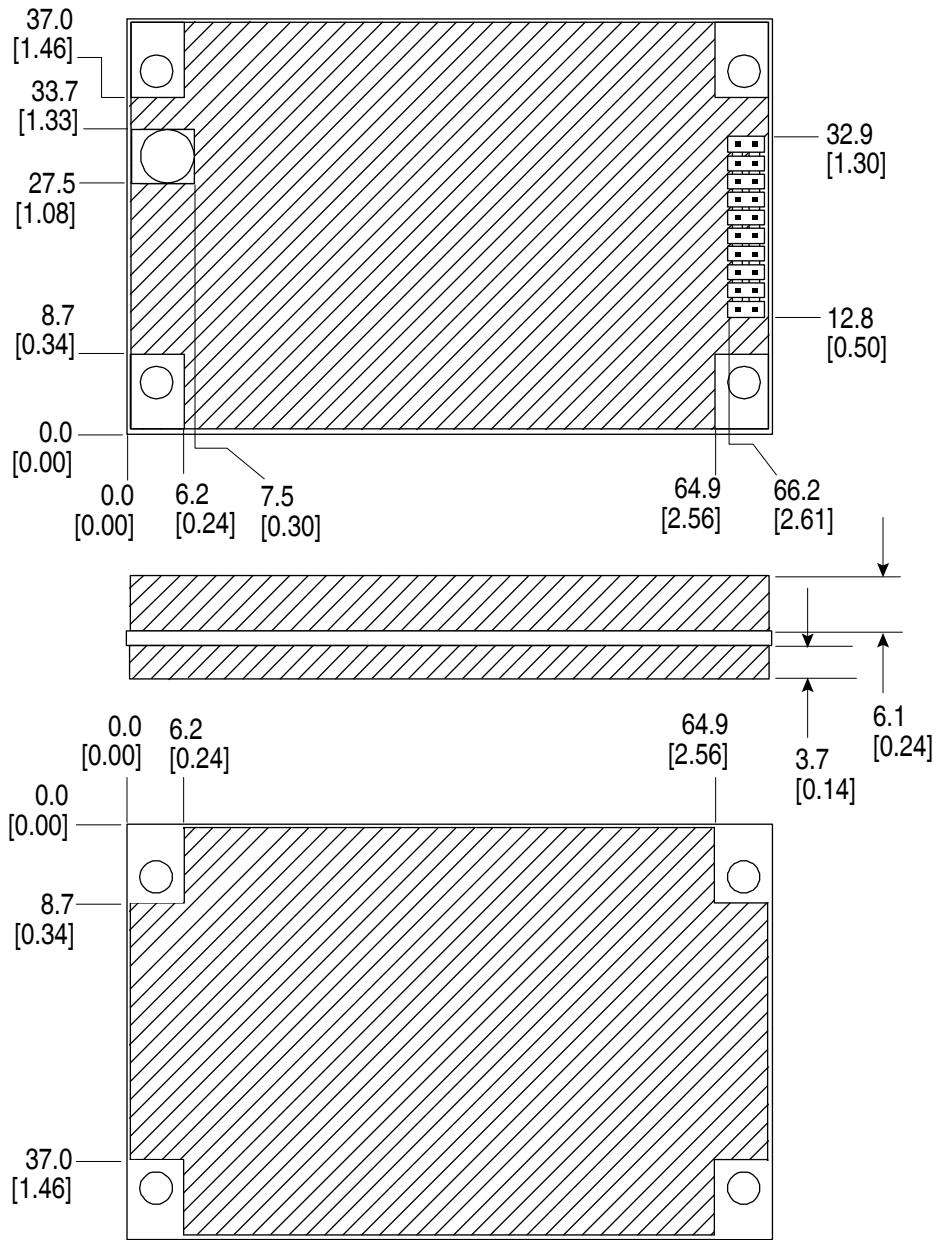



Figure 55: OEM615V Keep-Out Zone



Note:

1. Dimensions are in millimeters [inches].
2. Keep-out areas are intended for NovAtel circuitry.

ENVIRONMENTAL	
Operating Temperature	-40°C to +85°C
Storage Temperature	-55°C to +95°C
Humidity	MIL-STD-810G, Method 507.5 Procedure II (95%)
Random Vibration	MIL-STD 810G Method 514.6, Category 24 (7.7 g RMS)
Sinusoidal Vibration	IEC 60068-2-6 (5 g)
Bump	ISO 9022-31-06 (25 g)
Shock	Operating: MIL-STD-810G, Method 516.6, Procedure I (40 g) Non-operating: MIL-STD-810G, Method 516.6, Procedure V (75 g)
POWER REQUIREMENTS	
Voltage	+3.3 VDC \pm 5%
Allowable Input Voltage Ripple	100 mV p-p maximum
Power Consumption	<1.0 W typical, GPS L1/L2 1.1 W typical, GPS/GLONASS L1/L2 1.2 W typical, all on  Values can change with the number of satellites in view and the firmware version. Use them as a guide for what you might expect but not as absolute values.
In-Rush Power Consumption	6.0 A for less than 60 μ s (typical)
RF INPUT / LNA POWER OUTPUT	
Antenna Connector	MCX female, 50 Ω nominal impedance (See <i>Figure 52, OEM615 Board Dimensions</i> on page 114)
Acceptable RF Input Level	L1: -122 to -87 (signal) dBm, -161 to -141 (noise) dBm/Hz L2: -126 to -93 (signal) dBm, -161 to -141 (noise) dBm/Hz
RF Input Frequencies	GPS L1: 1575.42 MHz GPS L2: 1227.60 MHz GLONASS L1: 1593-1610 MHz GLONASS L2: 1237-1253 MHz Galileo E1: 1575.42 MHz BeiDou B1: 1561.098 MHz
LNA Power	+5 VDC \pm 5%, 0-100 mA (supplied by card through center conductor of RF connector). The output current in all instances is limited to 100 mA and above an input voltage of 6 V the output current limit is further reduced (derated) according to: $I_{out} < 0.1W / (V_{in} - 5V)$ where V_{in} is from 6 V to 12 V (J1101, Pin 1)

INPUT/OUTPUT DATA INTERFACE	
COM1	
Electrical format	LVTTTL
Bit rates ^a	2400, 4800, 9600 (default), 19200, 38400, 57600, 115200, 230400, 460800 or 921600 bps. See <i>Section 4.1.1, Serial Ports</i> on page 52
Signals supported	COM1_Tx, COM1_Rx
Electrostatic discharge protection	Yes
COM2	
Electrical format	LVTTTL
Bit rates ^a	2400, 4800, 9600 (default), 19200, 38400, 57600, 115200, 230400, 460800 or 921600 bps. See <i>Section 4.1.1, Serial Ports</i> on page 52
Signals supported	COM2_Tx, COM2_Rx
Electrostatic discharge protection	No
COM3	
Electrical format	LVTTTL ^{b c}
Bit rates ^a	2400, 4800, 9600 (default), 19200, 38400, 57600, 115200, 230400, 460800 or 921600 bps. See <i>Section 4.1.1, Serial Ports</i> on page 52
Signals supported	COM3_Tx and COM3_Rx
Electrostatic discharge protection	No
CAN BUS^D	
Electrical format	LVTTTL (requires external CAN transceiver)
Bit rates	1 Mbps maximum. CAN Bus throughput is determined by slowest device on the bus
Signals supported	CAN1 and CAN2
USB	
Electrical format	Conforms to USB 2.0
Bit rates	Full-speed USB
Signals supported	USB D (+), USB D (-)
ETHERNET	
Physical Layer	None

- a. Baud rates higher than 115,200 bps are not supported by standard PC hardware. Special computer hardware may be required for higher rates, including 230400 bps, 460800 bps and 921600 bps.
- b. COM3 is disabled by default. See *Section 4, OEM6 Card Default Serial Port Configurations* on page 39.
- c. Event2 is enabled by default, but is multiplexed with CAN1. CAN functionality must be disabled for Event2 to work properly. See *Section 4, OEM6 Card Default Serial Port Configurations* on page 39 for details
- d. CAN Bus behavior must be asserted through the NovAtel API software. See *Section 4.10.2, CAN Bus (not available on the FlexPak6D)* on page 74 for further details. See also *Figure 58, OEM615 CAN Transceiver Implementation Schematic* on page 123.

Table 15: OEM615 Strokes

Strokes	Default Behavior	Input/ Output	Factory Default	Comment ^a
Event1 (Mark 1)	Multiplexed pin	Input Leading edge triggered	Active low	An input mark for which a pulse greater than 150 ns triggers certain logs to be generated. (Refer to the MARKPOS and MARKTIME logs and ONMARK trigger.) Polarity is configurable using the MARKCONTROL command. The initial state (level) of the signal is HIGH.
Event2 (Mark 2)	Multiplexed pin	Input Leading edge triggered	Active low	An input mark for which a pulse greater than 150 ns triggers certain logs to be generated (see the MARK2POS and MARK2TIME logs). Polarity is configurable using the MARKCONTROL command. The initial state (level) of the signal is HIGH; To trigger an event (pull the pin low) a current sink of 9mA may be required.
PV (Position Valid)	Dedicated pin	Output	Active high	Indicates a valid GNSS position solution is available.
VARF (Variable Frequency)	Multiplexed pin	Output	Active low	A programmable variable frequency output ranging from 0 -5 MHz (refer to the FREQUENCYOUT command)
RESETIN	Dedicated pin	Input	Active low	Reset LVTTTL signal input from external system; active low, > 20 μ s duration. Hold the RESETIN pin low for >150 ms after power is applied
PPS	Dedicated pin	Output	Active low	A time synchronization output. This is a pulse where the leading edge is synchronized to receiver-calculated GNSS Time. The polarity, period and pulse width can be configured using PPSCONTROL command

a. The commands and logs shown in capital letters (for example, MARKCONTROL) are discussed in further detail in the [OEM6 Family Firmware Reference Manual](#) (OM-20000129).

Table 16: OEM615 Strobe Electrical Specification

Strobe	Sym	Min (V)	Typ (V)	Max (V)	Current (mA)	Conditions
Event1 (Mark 1)	V _{IL}			0.8		VCC = 3.3 V compatible; 85°C
Event2 (Mark2)	V _{IH}	2.0				
PPS	V _{OL}			0.55	24	VCC = 3.3 V; 85°C
	V _{OH}	2.3			24	
PV	V _{OL}			0.55	10	
	V _{OH}	2.2			10	
VARF	V _{OL}			0.55	24	
	V _{OH}	2.4			24	
RESETIN	V _{IL}			0.8		
	V _{IH}	2.3				

A.2 Top-view, P1101 Main Connector 20-Pin Header

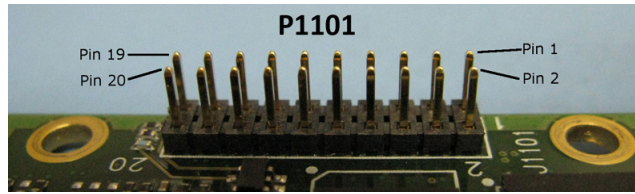

Pin	Signal	Type	Description	Comments
1	LNA_PWR	PWR	Antenna power input	An LDO regulates the output voltage to 5 VDC $\pm 5\%$. The input voltage should be 6 VDC to 12 VDC
2	3V3	PWR	Supply voltage input	3.3 V $\pm 5\%$
3	USB_D-	IO	USB data (-)	One-half of a differential pair (pins 3 and 4). Match lengths and route as a 90 Ω differential pair if USB is required
4	USB_D+ / RXD3 ^a	IO	USB data (+) / COM3 receive data	One-half of a differential pair (pins 3 and 4). Match lengths and route as a 90 Ω differential pair if USB is required This pin is internally multiplexed (see <i>Connecting Data Communications Equipment</i> on page 38)
5	/RESETIN	I	Reset input	Active low reset
6	USERVARF / CAN1RX	IO	Variable frequency output / CAN1 receive data	These pins are internally multiplexed (see <i>Section 2.5.3, Connecting Data Communications Equipment</i> on page 38)
7	EVENT2 / CAN1TX	IO	Event 2 Input / CAN1 transmit data	
8	CAN2RX	I	CAN2 receive data	
9	EVENT1 / TXD3 ^a	IO	Event1 input / COM3 transmit data	This pin is internally multiplexed (see <i>Connecting Data Communications Equipment</i> on page 38)
10	GND	PWR	Signal and power ground	
11	TXD1	O	COM1 transmit data	
12	RXD1	I	COM1 receive data	
13	GND	PWR	Signal and power ground	
14	TXD2	O	COM2 transmit data	
15	RXD2	I	COM2 receive data	
16	GND	PWR	Signal and power ground	
17	PV	O	Position valid indicator	Active high output
18	GND	PWR	Signal and power ground	
19	PPS ^b	O	Timemark output, synchronous to GPS time	This pin has an internal 50 ohm line driver. Route as a 50 Ω single-ended trace
20	CAN2TX	O	CAN2 transmit data	

a. The COM3 UART can be configured with firmware on pins 4 and 9.

b. The terms TIMEMARK and PPS are synonymous.

A.2.1 Logic-Level I/O

The OEM615 provides a number of Logic-level I/O pins for status indication and timing. These I/O include:

- COM1, COM2 and COM3: LVTTTL level UART ports (no flow control) (3.3 V I/O)
- CAN1 and CAN2: CMOS level CAN ports (require external CAN transceivers) (2.7 V I/O, 3.3V compatible levels)
- TIMEMARK: Output pulse providing time reference signal (software configurable output rate) (3.3 V I/O)
- VARF: Variable Frequency output (a software configurable clock output) (3.3 V I/O)
- PV: Position Valid (Goes high when the receiver has calculated a valid position) (3.3 V I/O)
- EVENT1 and EVENT2: Event inputs (configurable polarity) (2.7 V I/O, 3.3 V compatible levels)

These I/O require additional ESD protection if they are routed to connectors. The same ESD protection circuit shown below should be used on any OEM615 Logic-level signal that attaches to an enclosure connector. The ferrite bead and small value capacitor provide some immunity to electrostatic discharge events, but also reduce radiated and conducted emissions from the enclosure.

EVENT, PPS and PV Signal Protection

Use the following circuit to create adequate protection for the EVENTx and PPS outputs in most situations.

Figure 56: OEM615 ESD Protection for EVENT and PPS Strobes Schematic

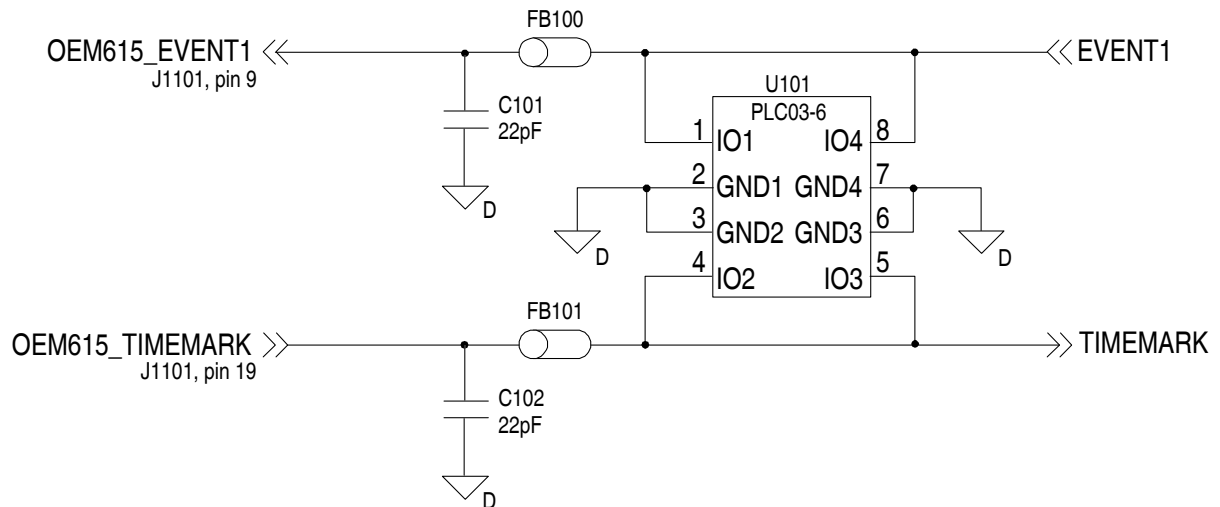

Use the PV signal to drive an LED with the buffer circuit below. This circuit indicates that the receiver card has computed a valid position:

Figure 57: OEM615 PV LED Drive Buffer Schematic

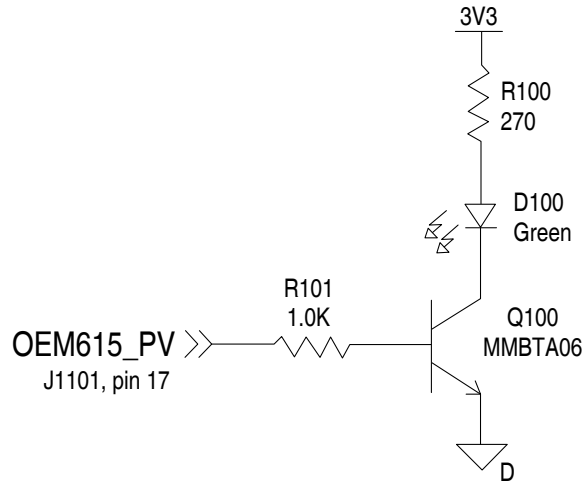

Table 17: Bill of Materials (critical components)

Designator	Manufacturer	Manufacturer Part Number
FB100, FB101	TDK	MMZ1005B800C
U101	Semtech	LC03-6.TBT
	Bourns	CDNBS08-PLC03-6
	OnSemi	LC03-6R2G
C101, C102	various	(22 pF 5% 50 V COG 0603)

A.2.2 CAN Interface

The OEM615 provides two 2.7V (3.3 V-compatible) CMOS-level CAN controller ports. An external transceiver is required. The following figure shows a typical CAN transceiver implementation.

The combination of ferrite beads and small value capacitors are not necessarily required but may provide improved EMI performance. A low capacitance TVS device provides ESD protection.

Figure 58: OEM615 CAN Transceiver Implementation Schematic

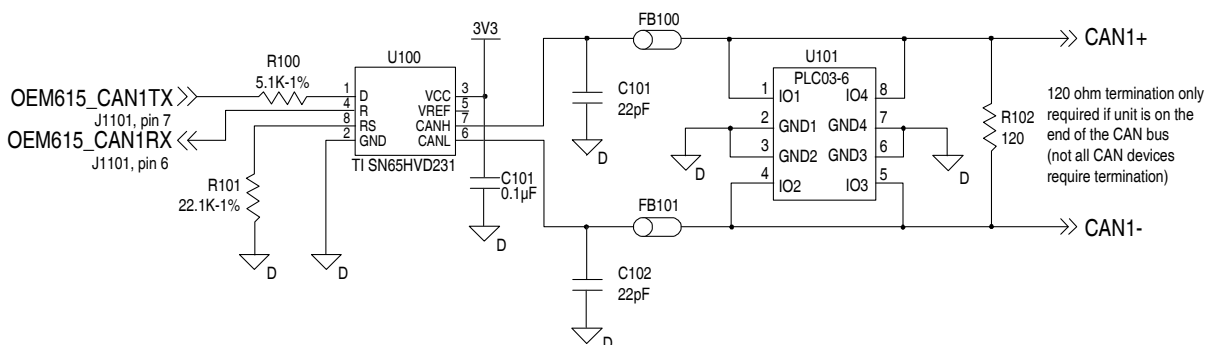

Only use a 120 Ω termination resistor when the CAN device is used at one end of the CAN bus. Multiple terminations along the length of the CAN bus will degrade performance for all CAN devices on the bus.

The slew rate adjustment resistor (R101) value in *Figure 58, OEM615 CAN Transceiver Implementation Schematic* on page 123 sets the slew rate for applications for SAE J1939 agricultural applications. Other applications may require a different slew rate. Refer to the transceiver product sheet for more information.

Table 18: Bill of Materials (critical components)

Designator	Manufacturer	Manufacturer Part Number
FB100, FB101	TDK	MMZ1005B800C
U100	Texas Instruments	SN65HVD231
U101	Semtech Bourns OnSemi	LC03-6.TBT CDNBS08-PLC03-6 LC03-6R2G
C100, C101	various	(22pF 5% 50V COG 0603)

A.2.3 USB Interface

The OEM615 includes one USB 2.0 full speed (12 Mbps) interface.

For signal integrity and EMI reasons, route differential data traces as a 90 Ω differential pair. A small value common mode choke (as shown in the figure below) may improve the radiated emissions performance.

The common mode choke and ESD protection should be placed as close as possible to the USB connector.

Figure 59: OEM615 USB Implementation Schematic

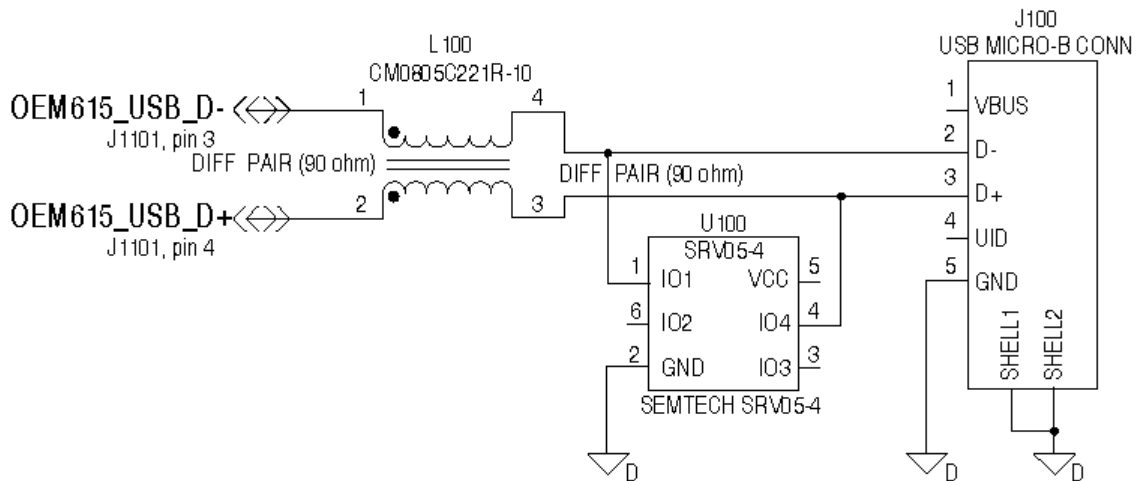

Table 19: Bill of Materials

Designator	Manufacturer	Manufacturer Part Number
L100	Steward / Laird	CM805-C221R-10
U100	Semtech	SRV05-4

B.1 OEM617 Receiver 617

PERFORMANCE (SUBJECT TO GPS SYSTEM CHARACTERISTICS)					
Position Accuracy ^a	Single point	L1 only	1.5 m RMS		
		L1/L2	1.2 m RMS		
	NovAtel CORRECT	SBAS ^b	0.6 m RMS		
		DGPS	0.4 m RMS		
		RTK	1 cm + 1 ppm RMS		
Time to First Fix	Hot: 35 s (Almanac and recent ephemeris saved and approximate position and time entered) Cold: 50 s (No almanac or ephemeris and no approximate position or time)				
Reacquisition	0.5 s L1 (typical) 1.0 s L2 (typical)				
Data Rates	Measurements	up to 50 Hz			
	Position	up to 50 Hz			
Time Accuracy ^{ac}	20 ns RMS				
Velocity Accuracy ^a	0.03 m/s RMS				
Measurement Precision		GPS		GLO	
		Code	Carrier	Code	Carrier
	L1 C/A	4 cm	0.5 mm	8 cm	1.0 mm
	L2 P(Y) ^d	8 cm	1.0 mm	8 cm	1.0 mm
	L2 C ^e	8 cm	0.5 mm	8 cm	1.0 mm
Dynamics	Velocity	515 m/s ^f			

a. Typical values. All position and velocity RMS values are based on Horizontal position accuracy. Performance specifications are subject to GPS system characteristics, U.S. DOD operational degradation, ionospheric and tropospheric conditions, satellite geometry, baseline length and multipath effects.

b. GPS-only.

c. Time accuracy does not include biases due to RF or antenna delay.

d. L2 P for GLONASS

e. L2 C/A for GLONASS

f. In accordance with export licensing.

B.1.1 Physical Description

PHYSICAL	
Size	46 mm x 71 mm x 11 mm
Weight	24 grams
NOVATEL PART NUMBER	
Generic assembly OEM617	01019264
MECHANICAL DRAWINGS	

Figure 60: OEM617 Board Dimensions

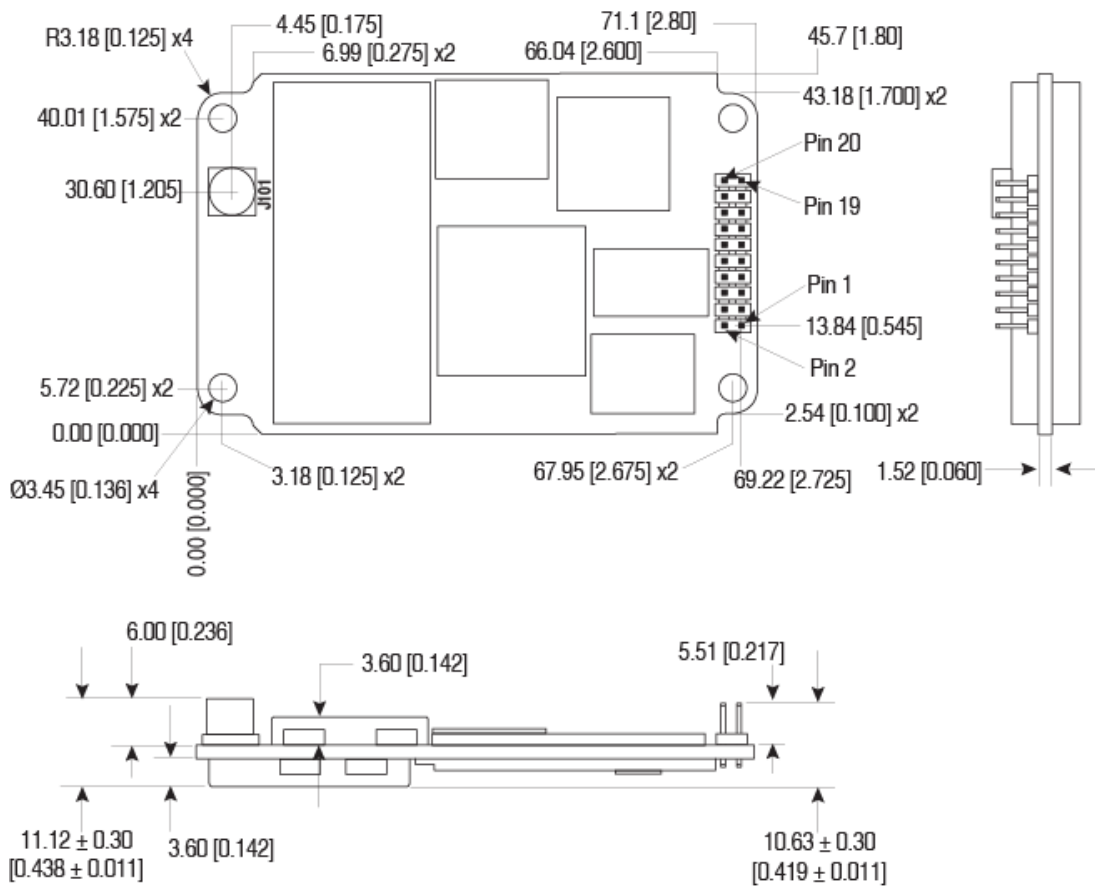

Notes:

1. Dimensions are in millimeters [inches].
2. Connectors:
 - (a) J101: MCX jack receptacle, straight (Johnson P/N 133-3711-202 or SAMTEC P/ N MCX- J-P-H-ST-SMI or equivalent)
 - (b) J1101: 2x10 header, 2 mm pitch (SAMTEC P/ N TMM-110-03-G-D)

Figure 61: OEM617 Keep-Out Zone

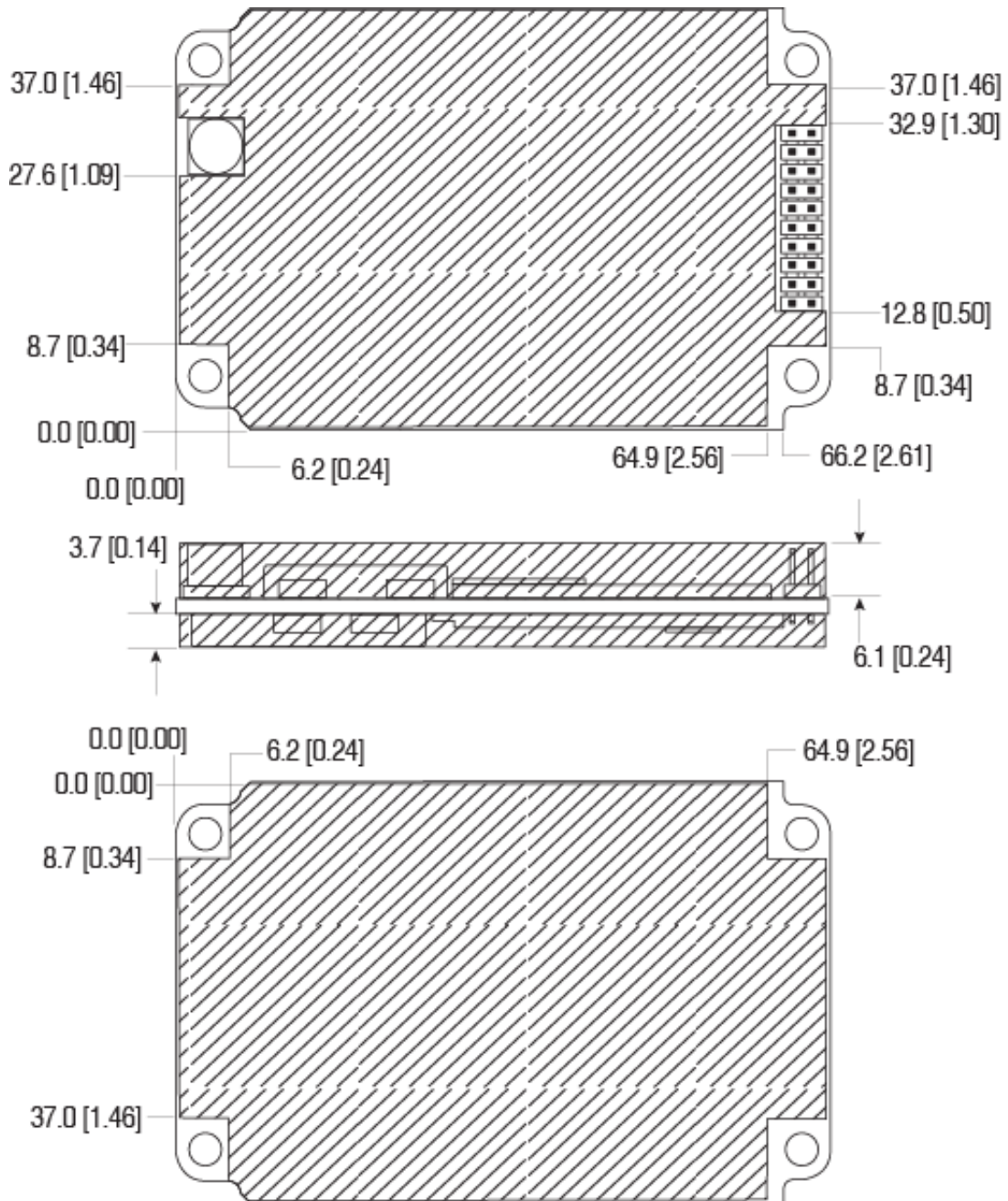

Note:

1. Dimensions are in millimeters [inches].
2. Keep-out areas are intended for NovAtel circuitry.

ENVIRONMENTAL	
Operating Temperature	-40°C to +85°C
Storage Temperature	-55°C to +95°C
Humidity	MIL-STD-810G, Method 507.5 Procedure II (95%)
Random Vibration	MIL-STD 810G Method 514.6, Category 24 (7.7 g RMS)
Sinusoidal Vibration	IEC 60068-2-6 (5 g)
Bump	ISO 9022-31-06 (25 g)
Shock	Operating: MIL-STD-810G, Method 516.6, Procedure I (40 g) Non-operating: MIL-STD-810G, Method 516.6, Procedure V (75 g)
POWER REQUIREMENTS	
Voltage	+3.3 V +5%/-3%
Allowable Input Voltage Ripple	100 mV p-p maximum
Power Consumption	<1.0 W typical, GPS L1/L2 1.1 W typical, GPS/GLONASS L1/L2 1.2 W typical, all on Values can change with the number of satellites in view and the firmware version. Use them as a guide for what you might expect but not as absolute values.
In-Rush Power Consumption	6.0 A for less than 60 μ s (typical)
RF INPUT / LNA POWER OUTPUT	
Antenna Connector	MCX female, 50 Ω nominal impedance (See <i>Figure 60, OEM617 Board Dimensions</i> on page 126)
Acceptable RF Input Level	L1: -122 to -87 (signal) dBm, -161 to -141 (noise) dBm/Hz L2: -126 to -93 (signal) dBm, -161 to -141 (noise) dBm/Hz
RF Input Frequencies	GPS L1: 1575.42 MHz GPS L2: 1227.60 MHz GLONASS L1: 1593-1610 MHz GLONASS L2: 1237-1253 MHz Galileo E1: 1575.42 MHz Galileo E5b: 1207.14 MHz BeiDou B1: 1561.098 MHz BeiDou B2: 1207.14 MHz
LNA Power	+5 VDC \pm 5%, 0-200 mA (supplied by card through center conductor of RF connector). The output current is limited to 200 mA. Above an input voltage of 6 V, the output current limit is further reduced (derated) according to: $I_{out} < 0.2W / (V_{in} - 5V)$ where V_{in} is from 6 V to 12 V (J1101, Pin 1)

INPUT/OUTPUT DATA INTERFACE	
COM1	
Electrical format	LVTTL
Bit rates ^a	2400, 4800, 9600 (default), 19200, 38400, 57600, 115200, 230400, 460800 or 921600 bps. See <i>Section 4.1.1, Serial Ports</i> on page 52
Signals supported	COM1_Tx, COM1_Rx
Electrostatic discharge protection	Yes
COM2	
Electrical format	LVTTL
Bit rates ^a	2400, 4800, 9600 (default), 19200, 38400, 57600, 115200, 230400, 460800 or 921600 bps. See <i>Section 4.1.1, Serial Ports</i> on page 52
Signals supported	COM2_Tx, COM2_Rx
Electrostatic discharge protection	No
COM3	
Electrical format	LVTTL ^{b c}
Bit rates ^a	2400, 4800, 9600 (default), 19200, 38400, 57600, 115200, 230400, 460800 or 921600 bps. See <i>Section 4.1.1, Serial Ports</i> on page 52
Signals supported	COM3_Tx and COM3_Rx
Electrostatic discharge protection	No
CAN BUS^D	
Electrical format	LVTTL (requires external CAN transceiver)
Bit rates	1 Mbps maximum. CAN Bus throughput is determined by slowest device on the bus
Signals supported	CAN1 and CAN2
USB	
Electrical format	Conforms to USB 2.0
Bit rates	Full-speed USB
Signals supported	USB D (+), USB D (-)
ETHERNET	
Physical Layer	None

- a. Baud rates higher than 115,200 bps are not supported by standard PC hardware. Special computer hardware may be required for higher rates, including 230400 bps, 460800 bps and 921600 bps.
- b. COM3 is disabled by default. See *Section 4, OEM6 Card Default Serial Port Configurations* on page 39.
- c. Event2 is enabled by default, but is multiplexed with CAN1. CAN functionality must be disabled for Event2 to work properly. See *Section 4, OEM6 Card Default Serial Port Configurations* on page 39 for details
- d. CAN Bus behavior must be asserted through the NovAtel API software. See *Section 4.10.2, CAN Bus (not available on the FlexPak6D)* on page 74 for further details. See also *Figure 65, OEM617 CAN Transceiver Implementation Schematic* on page 133.

Table 20: OEM617 Strokes

Strokes	Default Behavior	Input/ Output	Factory Default	Comment ^a
Event1 (Mark 1)	Multiplexed pin	Input Leading edge triggered	Active low	An input mark for which a pulse greater than 150 ns triggers certain logs to be generated. (Refer to the MARKPOS and MARKTIME logs and ONMARK trigger.) Polarity is configurable using the MARKCONTROL command. The initial state (level) of the signal is HIGH.
Event2 (Mark 2)	Multiplexed pin	Input Leading edge triggered	Active low	An input mark for which a pulse greater than 150 ns triggers certain logs to be generated (see the MARK2POS and MARK2TIME logs). Polarity is configurable using the MARKCONTROL command. The initial state (level) of the signal is HIGH; To trigger an event (pull the pin low) a current sink of 9mA may be required.
PV (Position Valid)	Dedicated pin	Output	Active high	Indicates a valid GNSS position solution is available.
VARF (Variable Frequency)	Multiplexed pin	Output	Active low	A programmable variable frequency output ranging from 0 -5 MHz (refer to the FREQUENCYOUT command)
RESETIN	Dedicated pin	Input	Active low	Reset LVTTTL signal input from external system; active low, > 20 μs duration
PPS	Dedicated pin	Output	Active low	A time synchronization output. This is a pulse where the leading edge is synchronized to receiver-calculated GNSS Time. The polarity, period and pulse width can be configured using PPSCONTROL command

a. The commands and logs shown in capital letters (for example, MARKCONTROL) are discussed in further detail in the [OEM6 Family Firmware Reference Manual](#) (OM-20000129).

Table 21: OEM617 Strobe Electrical Specification

Strobe	Sym	Min (V)	Typ (V)	Max (V)	Current (mA)	Conditions
Event1 (Mark 1)	V _{IL}			0.8		VCC = 3.3 V compatible; 85°C
Event2 (Mark2)	V _{IH}	2.0				
PPS	V _{OL}			0.55	24	VCC = 3.3 V; 85°C
	V _{OH}	2.3			24	
PV	V _{OL}			0.55	10	
	V _{OH}	2.2			10	
VARF	V _{OL}			0.55	24	
	V _{OH}	2.4			24	
RESETIN	V _{IL}			0.8		
	V _{IH}	2.3				

Figure 62: Top-view, P1101 Main Connector 20-Pin Header

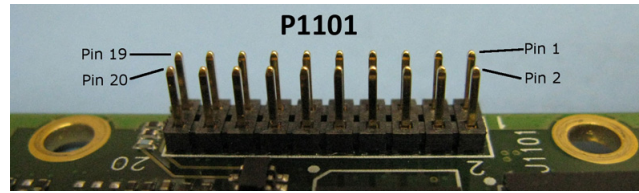

Pin	Signal	Type	Description	Comments
1	LNA_PWR	PWR	Antenna power input	An LDO regulates the output voltage to 5 VDC \pm 5%. The input voltage should be 6 VDC to 12 VDC
2	3V3	PWR	Supply voltage input	+3.3 V +5%/-3%
3	USB_D-	IO	USB data (-)	One-half of a differential pair (pins 3 and 4). Match lengths and route as a 90 Ω differential pair if USB is required
4	USB_D+ / RXD3 ^a	IO	USB data (+) / COM3 receive data	One-half of a differential pair (pins 3 and 4). Match lengths and route as a 90 Ω differential pair if USB is required This pin is internally multiplexed (see <i>Connecting Data Communications Equipment</i> on page 38)
5	/RESETIN	I	Reset input	Active low reset
6	USERVARF / CAN1RX	IO	Variable frequency output / CAN1 receive data	These pins are internally multiplexed (see <i>Connecting Data Communications Equipment</i> on page 38)
7	EVENT2 / CAN1TX	IO	Event 2 Input / CAN1 transmit data	
8	CAN2RX	I	CAN2 receive data	
9	EVENT1 / TXD3 ^a	IO	Event1 input / COM3 transmit data	This pin is internally multiplexed (see <i>Connecting Data Communications Equipment</i> on page 38)
10	GND	PWR	Signal and power ground	
11	TXD1	O	COM1 transmit data	
12	RXD1	I	COM1 receive data	
13	GND	PWR	Signal and power ground	
14	TXD2	O	COM2 transmit data	
15	RXD2	I	COM2 receive data	
16	GND	PWR	Signal and power ground	
17	PV	O	Position valid indicator	Active high output
18	GND	PWR	Signal and power ground	
19	PPS ^b	O	Timemark output, synchronous to GPS time	This pin has an internal 50 ohm line driver. Route as a 50 Ω single-ended trace
20	CAN2TX	O	CAN2 transmit data	

a. The COM3 UART can be configured with firmware on pins 4 and 9.

b. The terms TIMEMARK and PPS are synonymous.

B.1.2 Logic-Level I/O

The OEM617 provides a number of Logic-level I/O pins for status indication and timing. These I/O include:

- COM1, COM2 and COM3: LVTTTL level UART ports (no flow control) (3.3 V I/O)
- CAN1 and CAN2: CMOS level CAN ports (require external CAN transceivers) (2.7 V I/O, 3.3V compatible levels)
- TIMEMARK: Output pulse providing time reference signal (software configurable output rate) (3.3 V I/O)
- VARF: Variable Frequency output (a software configurable clock output) (3.3 V I/O)
- PV: Position Valid (Goes high when the receiver has calculated a valid position) (3.3 V I/O)
- EVENT1 and EVENT2: Event inputs (configurable polarity) (2.7 V I/O, 3.3 V compatible levels)

These I/O require additional ESD protection if they are routed to connectors. The same ESD protection circuit shown below should be used on any OEM617 Logic-level signal that attaches to an enclosure connector. The ferrite bead and small value capacitor provide some immunity to electrostatic discharge events, but also reduce radiated and conducted emissions from the enclosure.

EVENT, PPS and PV Signal Protection

Use the following circuit to create adequate protection for the EVENTx and PPS outputs in most situations.

Figure 63: OEM617 ESD Protection for EVENT and PPS Strobes Schematic

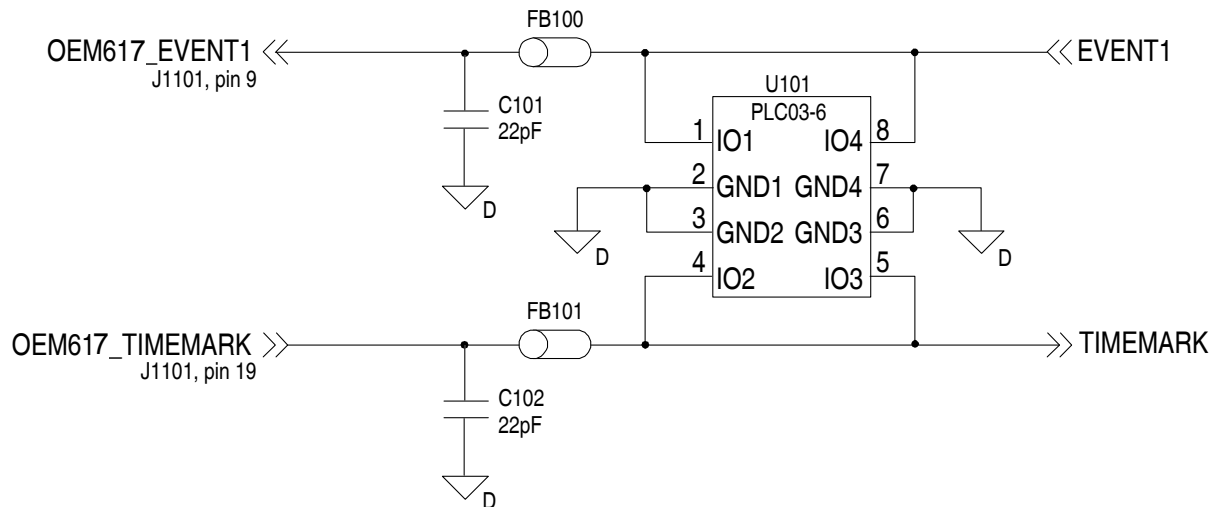

Use the PV signal to drive an LED with the buffer circuit below. This circuit indicates that the receiver card has computed a valid position:

Figure 64: OEM617 PV LED Drive Buffer Schematic

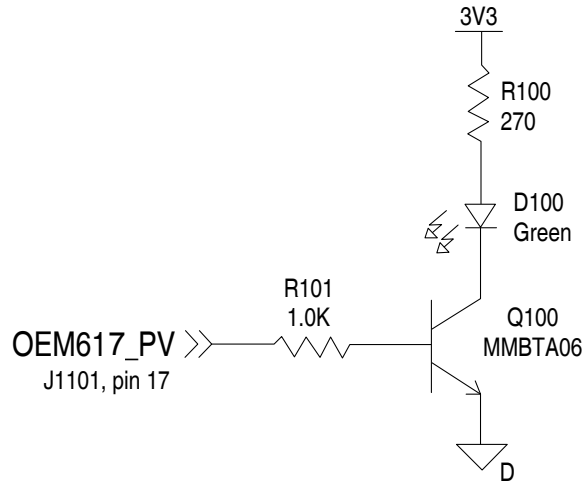

Table 22: Bill of Materials (critical components)

Designator	Manufacturer	Manufacturer Part Number
FB100, FB101	TDK	MMZ1005B800C
U101	Semtech	LC03-6.TBT
	Bourns	CDNBS08-PLC03-6
	OnSemi	LC03-6R2G
C101, C102	various	(22 pF 5% 50 V COG 0603)

B.1.3 CAN Interface

The OEM617 provides two 2.7V (3.3 V-compatible) CMOS-level CAN controller ports. An external transceiver is required. The following figure shows a typical CAN transceiver implementation.

The combination of ferrite beads and small value capacitors are not necessarily required but may provide improved EMI performance. A low capacitance TVS device provides ESD protection.

Figure 65: OEM617 CAN Transceiver Implementation Schematic

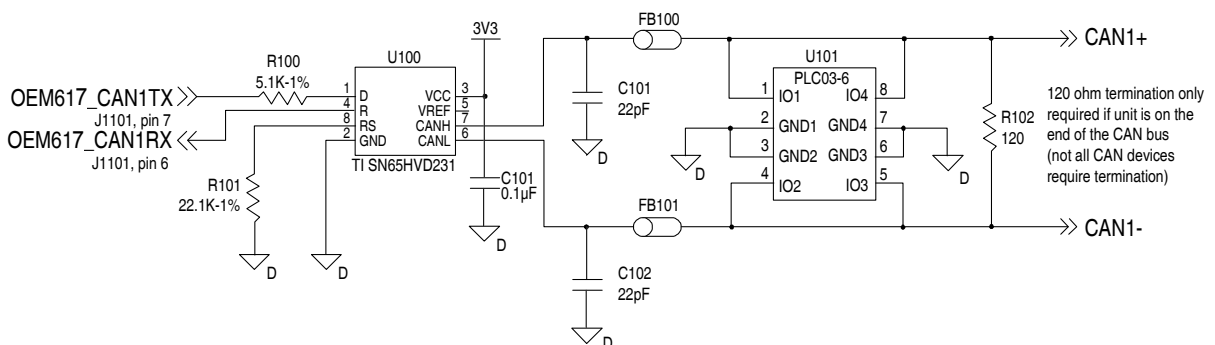

Only use a 120 Ω termination resistor when the CAN device is used at one end of the CAN bus. Multiple terminations along the length of the CAN bus will degrade performance for all CAN devices on the bus.

The slew rate adjustment resistor (R101) value in *Figure 65, OEM617 CAN Transceiver Implementation Schematic* on page 133 sets the slew rate for applications for SAE J1939 agricultural applications. Other applications may require a different slew rate. Refer to the transceiver product sheet for more information.

Table 23: Bill of Materials (critical components)

Designator	Manufacturer	Manufacturer Part Number
FB100, FB101	TDK	MMZ1005B800C
U100	Texas Instruments	SN65HVD231
U101	Semtech Bourns OnSemi	LC03-6.TBT CDNBS08-PLC03-6 LC03-6R2G
C100, C101	various	(22pF 5% 50V COG 0603)

B.1.4 USB Interface

The OEM617 includes one USB 2.0 full speed (12 Mbps) interface.

For signal integrity and EMI reasons, route differential data traces as a 90 Ω differential pair. A small value common mode choke (as shown in the figure below) may improve the radiated emissions performance.

The common mode choke and ESD protection should be placed as close as possible to the USB connector.

Figure 66: OEM617 USB Implementation Schematic

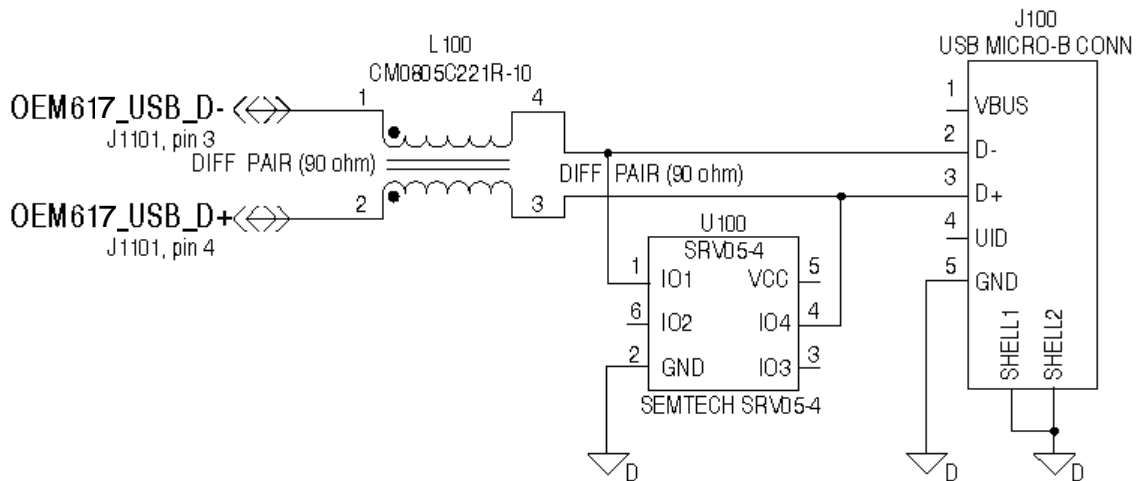

Table 24: Bill of Materials

Designator	Manufacturer	Manufacturer Part Number
L100	Steward / Laird	CM805-C221R-10
U100	Semtech	SRV05-4

C.1 OEM617D Receiver **617D**

PERFORMANCE (SUBJECT TO GPS SYSTEM CHARACTERISTICS)			
Position Accuracy ^a	Single point	L1 only	1.5 m RMS
		L1/L2	1.2 m RMS
	NovAtel CORRECT	SBAS ^b	0.6 m RMS
		DGPS	0.4 m RMS
		RTK	1 cm + 1 ppm RMS
Time to First Fix	Hot: 35 s (Almanac and recent ephemeris saved and approximate position and time entered) Cold: 50 s (No almanac or ephemeris and no approximate position or time)		
Reacquisition	0.5 s L1 (typical) 1.0 s L2 (typical)		
Data Rates ^c	Measurements	up to 20 Hz maximum	
	Position	up to 20 Hz maximum	
Time Accuracy ^{ad}	20 ns RMS		
Velocity Accuracy ^a	0.03 m/s RMS		
ALIGN Heading Accuracy ^{ac}	Baseline	Accuracy (RMS)	
	2 m	0.08 deg	
	4 m	0.05 deg	
Dynamics	Velocity	515 m/s ^e	

a. Typical values. All position and velocity RMS values are based on Horizontal position accuracy. Performance specifications are subject to GPS system characteristics, U.S. DOD operational degradation, ionospheric and tropospheric conditions, satellite geometry, baseline length and multipath effects.

b. GPS-only.

c. Rates are model dependent.

d. Time accuracy does not include biases due to RF or antenna delay.

e. In accordance with export licensing.

C.1.1 Physical Description

PHYSICAL	
Size	46 mm x 71 mm x 11 mm
Weight	24 grams
NOVATEL PART NUMBER	
Generic assembly OEM617D	01019268
MECHANICAL DRAWINGS	

Figure 67: OEM617D Board Dimensions

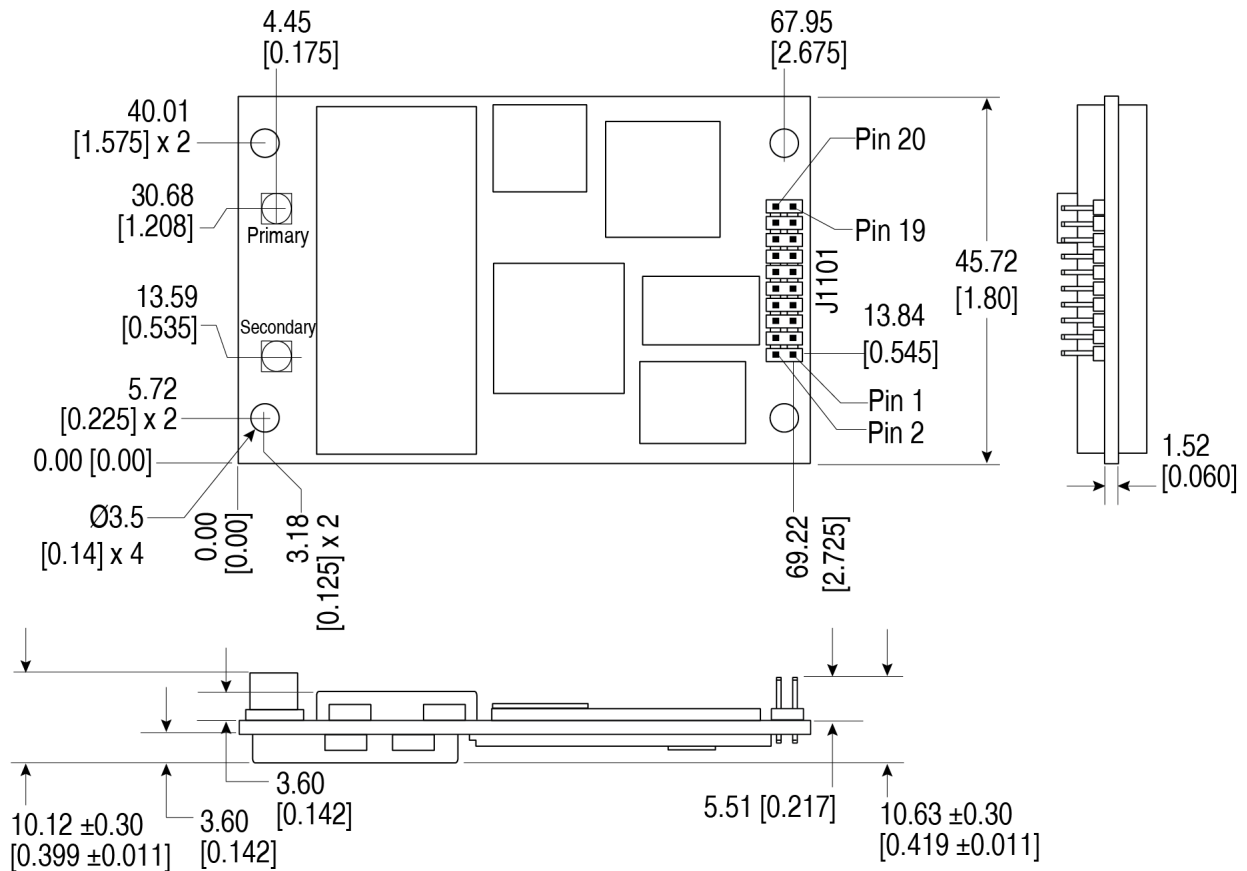

Notes:

1. Dimensions are in millimeters [inches].
2. Connectors:
 - (a) Primary and Secondary: MMCX jack receptacle, straight (Johnson P/N 135-3711-201 or Molex P/N 73415-2063 or equivalent)
 - (b) J1101: 2x10 header, 2 mm pitch (Samtec P/N TMM-110-03-G-D)
3. Mounting holes are symmetrical.

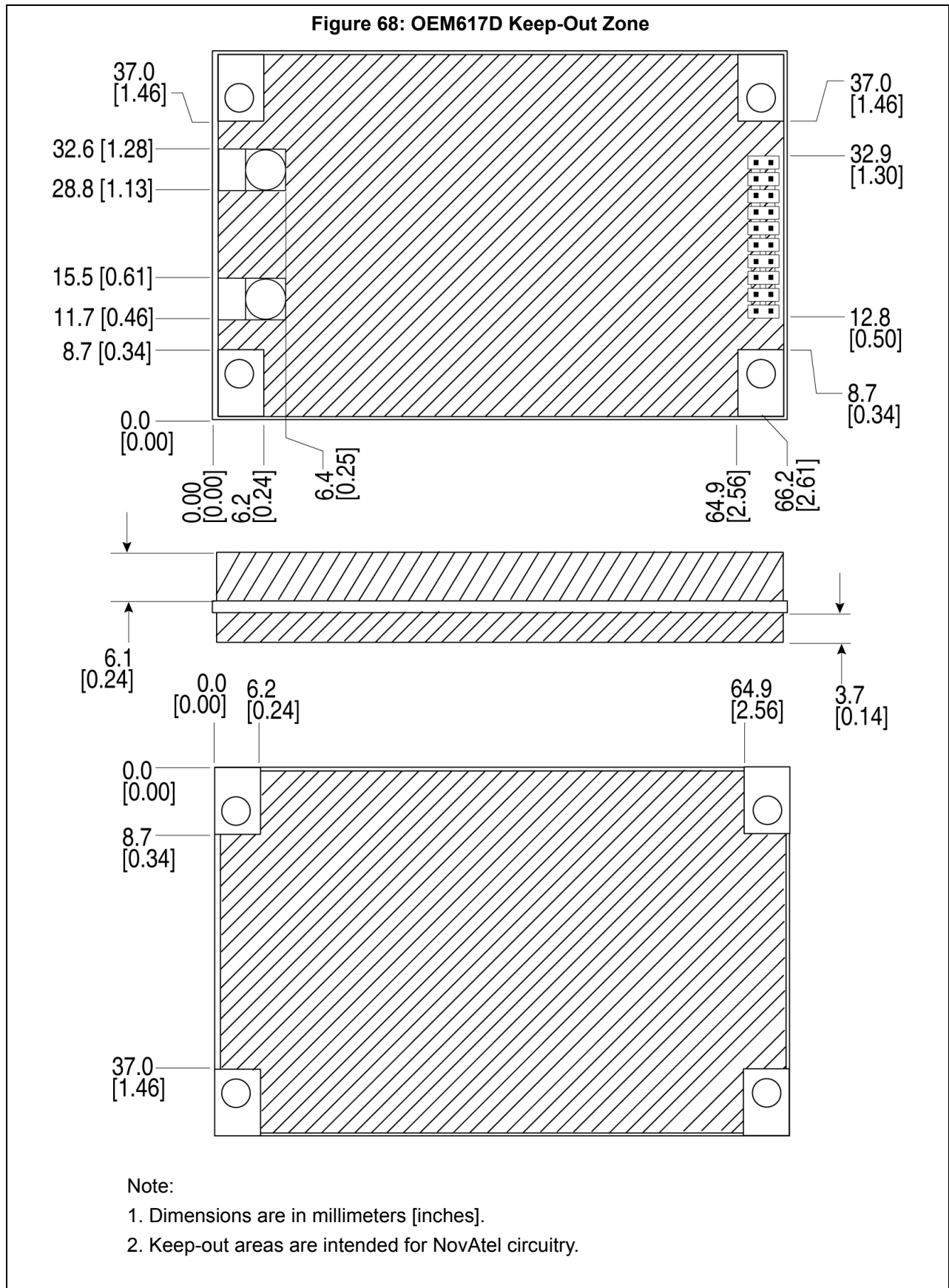

ENVIRONMENTAL	
Operating Temperature	-40°C to +85°C
Storage Temperature	-55°C to +95°C
Humidity	95% non-condensing
Random Vibe	MIL-STD-810G Method 514.6 (category 24, 7.7 g RMS)
Sine Vibe	IEC 60068-2-6 (Test Fc - 5 g)
Bump / Repetitive shock	ISO 9022-31-06 (25 g)
Shock	MIL-STD-810G Method 516.6 (40 g)
POWER REQUIREMENTS	
Input voltage	+3.3 VDC +5%/-3%
Allowable Input Voltage Ripple	100 mV p-p maximum
Power Consumption	1.9 W typical, GPS L1/L2 <2.0 W typical, GPS+GLONASS L1/L2 <2.1 W typical, GPS+BDS+GLONASS L1/L2/B1/B2  Values can change with the number of satellites in view and the firmware version. Use them as a guide for what you might expect but not as absolute values.
In-Rush Power Consumption	6.0 A for less than 60 μs (typical)
RF INPUT	
Antenna Connector	MMCX female, 50 Ω nominal impedance (See <i>Figure 67, OEM617D Board Dimensions</i> on page 136)
Acceptable RF Input Level	L1: -122 to -87 (signal) dBm, -161 to -141 (noise) dBm/Hz L2: -126 to -93 (signal) dBm, -161 to -141 (noise) dBm/Hz
RF Input Frequencies	GPS L1: 1575.42 MHz Galileo E1: 1575.42 MHz GPS L2: 1227.60 MHz Galileo E5b: 1207.14 MHz GLONASS L1: 1593-1610 MHz BeiDou B1: 1561.098 MHz GLONASS L2: 1237-1253 MHz BeiDou B2: 1207.14 MHz
LNA POWER OUTPUT	
LNA Voltage	5.0 VDC ±5% to each antenna (supplied by card through center conductor of RF connector)
LNA Current	0-100 mA to each antenna in dual antenna use case 0-200 mA to primary antenna in single antenna use case
LNA Current Limit	The output current for dual antenna use is limited to 100 mA for each antenna. Above an input voltage of 6 V, the output current limit is further reduced (derated) according to: $I_{out} < 0.1W / (V_{in} - 5V)$ where V_{in} is from 6 V to 12 V (J1101, Pin 1) The output current for single antenna use is limited to 200 mA on the primary antenna. Above an input voltage of 6 V, the output current limit is further reduced (derated) according to: $I_{out} < 0.2W / (V_{in} - 5V)$ where V_{in} is from 6 V to 12 V (J1101, Pin 1)

INPUT/OUTPUT DATA INTERFACE	
COM1	
Electrical format	LVTTTL
Bit rates ^a	300, 1200, 2400, 4800, 9600 (default), 19200, 38400, 57600, 115200, 230400, 460800 or 921600 bps. See <i>Serial Ports</i> on page 52)
Signals supported	COM1_Tx, COM1_Rx
Electrostatic discharge protection	No
COM2	
Electrical format	LVTTTL
Bit rates ^a	300, 1200, 2400, 4800, 9600 (default), 19200, 38400, 57600, 115200, 230400, 460800 or 921600 bps. See <i>Serial Ports</i> on page 52
Signals supported	COM2_Tx, COM2_Rx
Electrostatic discharge protection	No
COM3	
Electrical format	LVTTTL ^{b c}
Bit rates ^a	300, 1200, 2400, 4800, 9600 (default), 19200, 38400, 57600, 115200, 230400, 460800 or 921600 bps. See <i>Serial Ports</i> on page 52
Signals supported	COM3_Tx and COM3_Rx
Electrostatic discharge protection	No
CAN BUS^d	
Electrical format	LVTTTL (requires external CAN transceiver)
Bit rates	1 Mbps maximum. CAN Bus throughput is determined by slowest device on the bus
Signals supported	CAN1 and CAN2
USB	
Electrical format	Conforms to USB 2.0
Bit rates	Full-speed USB
Signals supported	USB D (+), USB D (-)
ETHERNET	
Physical Layer	None

a. Baud rates higher than 115,200 bps are not supported by standard PC hardware. Special computer hardware may be required for higher rates, including 230400 bps, 460800 bps and 921600 bps.

b. COM3 is disabled by default. See *OEM6 Card Default Serial Port Configurations* on page 39.

c. Event2 is enabled by default, but is multiplexed with CAN1. CAN functionality must be disabled for Event2 to work properly. See *OEM6 Card Default Serial Port Configurations* on page 39.

Table 25: OEM617D Strobes

Strobes	Default Behavior	Input/Output	Factory Default	Comment ^a
Event1 (Mark 1)	Multiplexed pin	Input Leading edge triggered	Active low	An input mark for which a pulse greater than 150 ns triggers certain logs to be generated. (Refer to the MARKPOS and MARKTIME logs and ONMARK trigger.) Polarity is configurable using the MARKCONTROL command. The initial state (level) of the signal is HIGH.
Event2 (Mark 2)	Multiplexed pin	Input Leading edge triggered	Active low	An input mark for which a pulse greater than 150 ns triggers certain logs to be generated (see the MARK2POS and MARK2TIME logs). Polarity is configurable using the MARKCONTROL command. The initial state (level) of the signal is HIGH; To trigger an event (pull the pin low) a current sink of 9mA may be required.
PV (Position Valid)	Dedicated pin	Output	Active high	Indicates a valid GNSS position solution is available.
VARF (Variable Frequency)	Multiplexed pin	Output	Active low	A programmable variable frequency output ranging from 0 -5 MHz (refer to the FREQUENCYOUT command)
RESETIN	Dedicated pin	Input	Active low	Reset LVTTTL signal input from external system; active low, > 20 μ s duration
PPS	Dedicated pin	Output	Active low	A time synchronization output. This is a pulse where the leading edge is synchronized to receiver-calculated GNSS Time. The polarity, period and pulse width can be configured using PPSCONTROL command

a. The commands and logs shown in capital letters (for example, MARKCONTROL) are discussed in further detail in the [OEM6 Family Firmware Reference Manual](#) (OM-20000129).

Table 26: OEM617D Strobe Electrical Specification

Strobe	Sym	Min (V)	Typ (V)	Max (V)	Current (mA)	Conditions
Event1 (Mark 1)	V _{IL}			0.8		VCC = 3.3 V compatible; 85°C
Event2 (Mark2)	V _{IH}	2.0				
PPS	V _{OL}			0.55	24	VCC = 3.3 V; 85°C
	V _{OH}	2.3			24	
PV	V _{OL}			0.55	10	
	V _{OH}	2.2			10	
VARF	V _{OL}			0.55	24	
	V _{OH}	2.4			24	
RESETIN	V _{IL}			0.8		
	V _{IH}	2.3				

Figure 69: Top-view, P1101 Main Connector 20-Pin Header

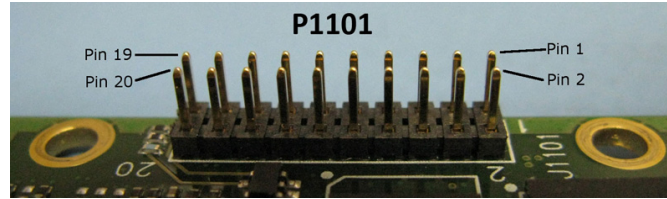

Pin	Signal	Type	Description	Comments
1	LNA_PWR	PWR	Antenna power input	An LDO regulates the output voltage to 5 VDC $\pm 5\%$. The input voltage should be 6 VDC to 12 VDC
2	3V3	PWR	Supply voltage input	3.3 V $+5\%/-3\%$
3	USB_D-	IO	USB data (-)	One-half of a differential pair (pins 3 and 4). Match lengths and route as a 90 Ω differential pair if USB is required
4	USB_D+ / RXD3 ^a	IO	USB data (+) / COM3 receive data	One-half of a differential pair (pins 3 and 4). Match lengths and route as a 90 Ω differential pair if USB is required This pin is internally multiplexed. See <i>Connecting Data Communications Equipment</i> on page 38.
5	RESETIN	I	Reset input	Active low reset
6	USERVARF / CAN1RX	IO	Variable frequency output / CAN1 receive data	These pins are internally multiplexed. See <i>Connecting Data Communications Equipment</i> on page 38
7	EVENT2 / CAN1TX	IO	Event 2 Input / CAN1 transmit data	
8	CAN2RX	I	CAN2 receive data	
9	EVENT1 / TXD3 ^a	IO	Event1 input / COM3 transmit data	This pin is internally multiplexed. See <i>Connecting Data Communications Equipment</i> on page 38.
10	GND	PWR	Signal and power ground	
11	TXD1	O	COM1 transmit data	
12	RXD1	I	COM1 receive data	
13	GND	PWR	Signal and power ground	
14	TXD2	O	COM2 transmit data	
15	RXD2	I	COM2 receive data	
16	GND	PWR	Signal and power ground	
17	PV	O	Position valid indicator	Active high output
18	GND	PWR	Signal and power ground	
19	PPS ^b	O	Timemark output, synchronous to GPS time	This pin has an internal 50 ohm line driver. Route as a 50 Ω single-ended trace
20	CAN2TX	O	CAN2 transmit data	

a. The COM3 UART can be configured with firmware on pins 4 and 9.

b. The terms TIMEMARK and PPS are synonymous.

C.1.2 Logic-Level I/O

The OEM617D provides a number of Logic-level I/O pins for status indication and timing. These I/O include:

- COM1, COM2 and COM3: LVTTTL level UART ports (no flow control) (3.3 V I/O)
- CAN1 and CAN2: CMOS level CAN ports (require external CAN transceivers) (2.7 V I/O, 3.3V compatible levels)
- TIMEMARK: Output pulse providing time reference signal (software configurable output rate) (3.3 V I/O)
- VARF: Variable Frequency output (a software configurable clock output) (3.3 V I/O)
- PV: Position Valid (Goes high when the receiver has calculated a valid position) (3.3 V I/O)
- EVENT1 and EVENT2: Event inputs (configurable polarity) (2.7 V I/O, 3.3 V compatible levels)

These I/O require additional ESD protection if they are routed to connectors. The same ESD protection circuit shown below should be used on any OEM617D Logic-level signal that attaches to an enclosure connector. The ferrite bead and small value capacitor provide some immunity to electrostatic discharge events, but also reduce radiated and conducted emissions from the enclosure.

EVENT, PPS and PV Signal Protection

Use the following circuit to create adequate protection for the EVENTx and PPS outputs in most situations.

Figure 70: OEM617D ESD Protection for EVENT and PPS Strobes Schematic

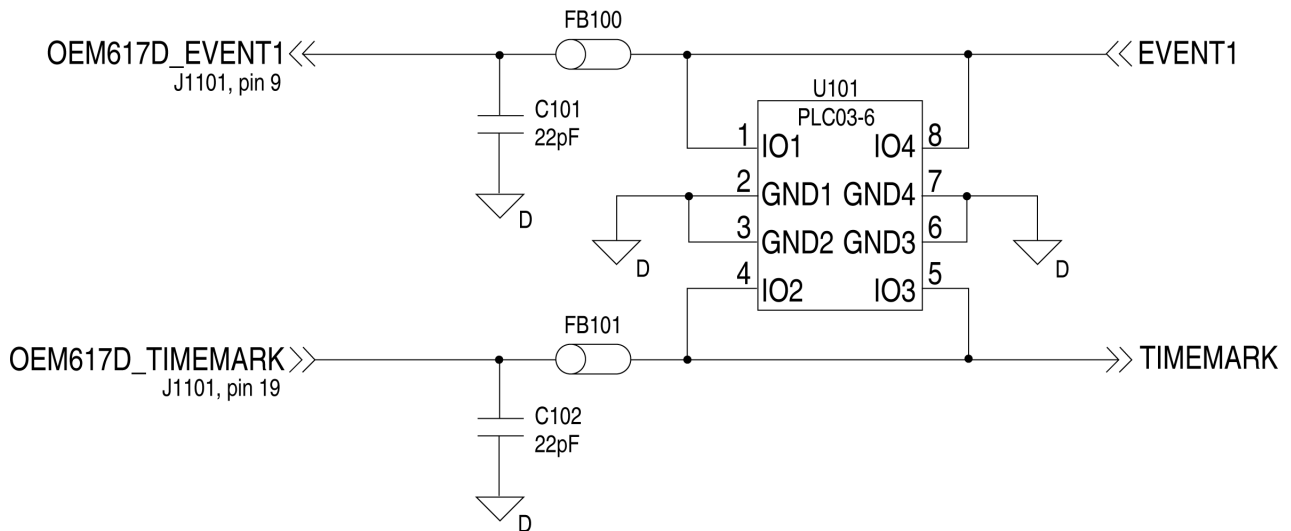

Use the PV signal to drive an LED with the buffer circuit below. This circuit indicates that the receiver card has computed a valid position:

Figure 71: OEM617D PV LED Drive Buffer Schematic

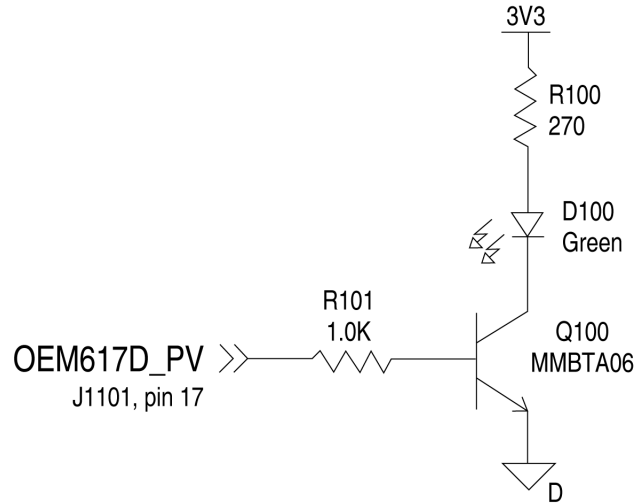

Table 27: Bill of Materials (critical components)

Designator	Manufacturer	Manufacturer Part Number
FB100, FB101	TDK	MMZ1005B800C
U101	Semtech Bourns OnSemi	LC03-6.TBT CDNBS08-PLC03-6 LC03-6R2G
C101, C102	various	(22 pF 5% 50 V COG 0603)

C.1.3 CAN Interface

The OEM617D provides two 2.7 V (3.3 V-compatible) CMOS-level CAN controller ports. An external transceiver is required. The following figure shows a typical CAN transceiver implementation.

The combination of ferrite beads and small value capacitors are not necessarily required but may provide improved EMI performance. A low capacitance TVS device provides ESD protection.

Figure 72: OEM617D CAN Transceiver Implementation Schematic

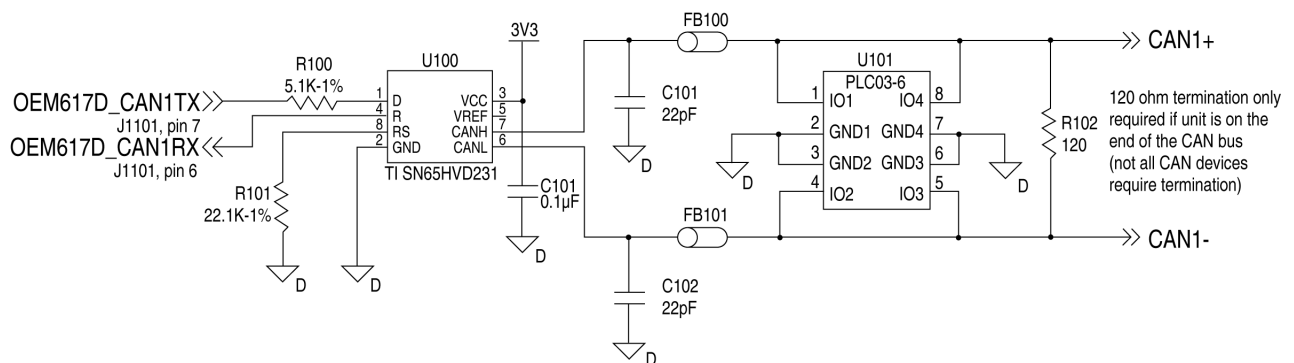

Only use a 120 Ω termination resistor when the CAN device is used at one end of the CAN bus. Multiple terminations along the length of the CAN bus will degrade performance for all CAN devices on the bus.

The slew rate adjustment resistor (R101) value in *Figure 72, OEM617D CAN Transceiver Implementation Schematic* on page 143 sets the slew rate for applications for SAE J1939 agricultural applications. Other applications may require a different slew rate. Refer to the transceiver product sheet for more information.

Table 28: Bill of Materials (critical components)

Designator	Manufacturer	Manufacturer Part Number
FB100, FB101	TDK	MMZ1005B800C
U100	Texas Instruments	SN65HVD231
U101	Semtech Bourns OnSemi	LC03-6.TBT CDNBS08-PLC03-6 LC03-6R2G
C100, C101	various	(22pF 5% 50V COG 0603)

C.1.4 USB Interface

The OEM617D includes one USB 2.0 full speed (12 Mbps) interface.

For signal integrity and EMI reasons, route differential data traces as a 90 Ω differential pair. A small value common mode choke (as shown in the figure below) may improve the radiated emissions performance.

The common mode choke and ESD protection should be placed as close as possible to the USB connector.

Figure 73: OEM617D USB Implementation Schematic

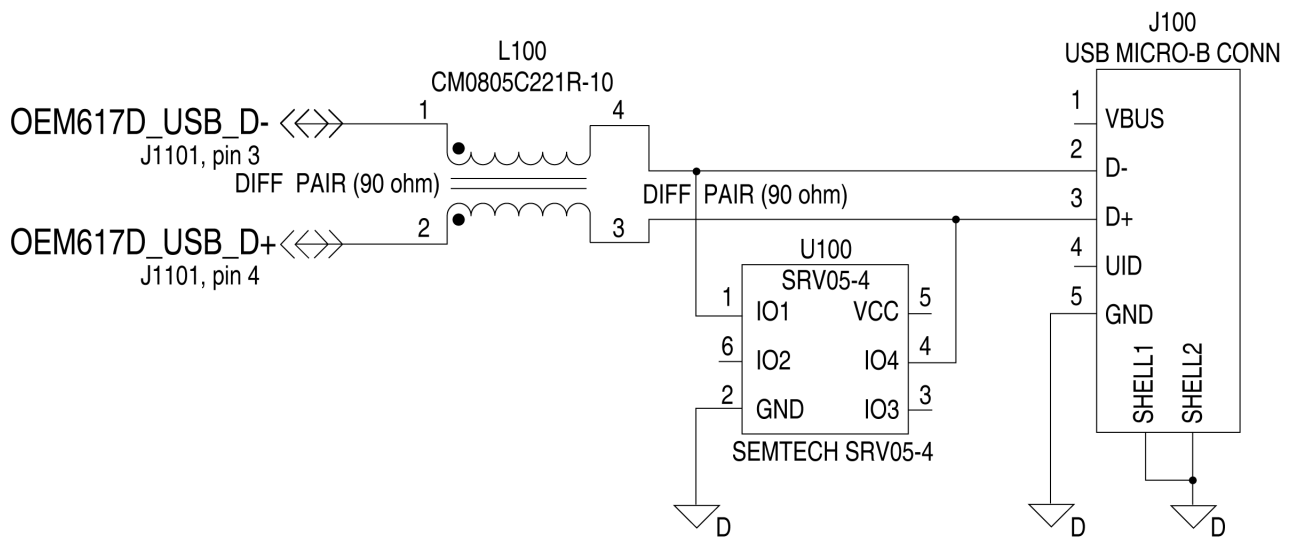

Table 29: Bill of Materials

Designator	Manufacturer	Manufacturer Part Number
L100	Steward / Laird	CM805-C221R-10
U100	Semtech	SRV05-4

D.1 OEM628 Receiver **628**

PERFORMANCE (SUBJECT TO GPS SYSTEM CHARACTERISTICS)					
Position Accuracy ^a	Single point	L1 only	1.5 m RMS		
		L1/L2	1.2 m RMS		
	NovAtel CORRECT	SBAS ^b	60 cm RMS		
		DGPS	40 cm RMS		
		PPP ^{cd} TerraStar-L TerraStar-C	40 cm RMS	4 cm RMS	
		RTK	1 cm + 1 ppm RMS		
Time to First Fix	Hot: <35 s (Almanac and recent ephemeris saved and approximate position and time entered) Cold: <50 s (No almanac or ephemeris and no approximate position or time)				
Reacquisition	0.5 s L1 (typical) 1.0 s L2 and L5 (typical)				
Data Rates	Measurements	100 Hz			
	Position	100 Hz			
Time Accuracy ^{ae}	20 ns RMS				
Velocity Accuracy ^a	0.03 m/s RMS				
Measurement Precision		GPS		GLO	
		Code	Carrier	Code	Carrier
	L1 C/A	4 cm	0.5 mm	8 cm	1.0 mm
	L2 P(Y) ^f	8 cm	1.0 mm	8 cm	1.0 mm
	L2 C ^g	8 cm	0.5 mm	8 cm	1.0 mm
	L5	3 cm	0.5 mm	-	-
Dynamics	Velocity	515 m/s ^h			

a. Typical values. All position and velocity RMS values are based on Horizontal position accuracy. Performance specifications are subject to GPS system characteristics, U.S. DOD operational degradation, ionospheric and tropospheric conditions, satellite geometry, baseline length and multipath effects.

b. GPS-only.

c. Requires a TerraStar subscription which is available direct from NovAtel www.novatel.com/products/novatel-correct-ppp.

d. Performance dependent on local observing conditions.

e. Time accuracy does not include biases due to RF or antenna delay.

f. L2 P for GLONASS.

g. L2 C/A for GLONASS.

h. In accordance with export licensing.

D.1.1 Physical Description

PHYSICAL	
Size	60 mm x 100 mm x 9.11 mm
Weight	37 grams
NOVATEL PART NUMBER	
Generic Assembly OEM628	01018410

Figure 74: OEM628 Board Dimensions

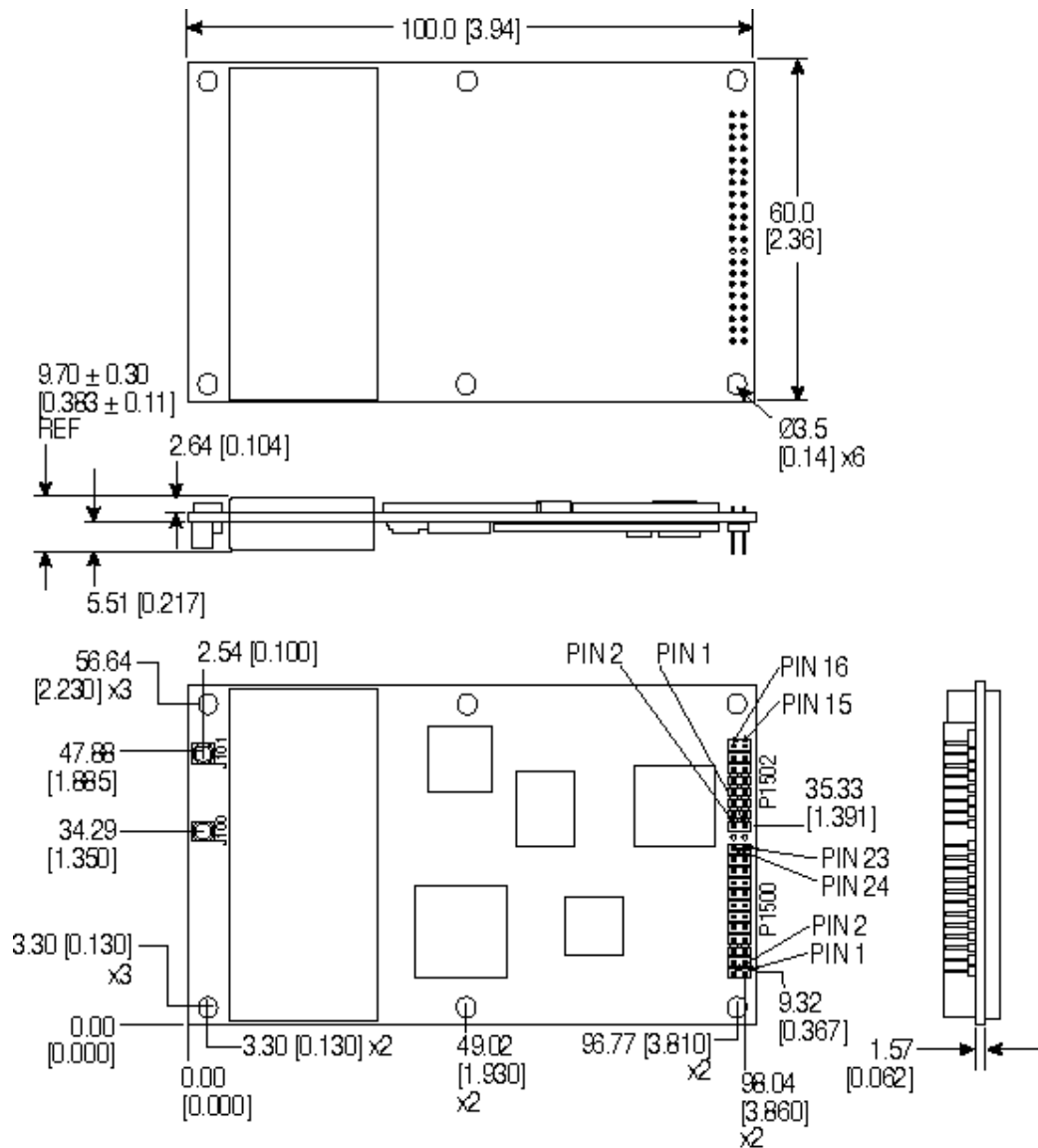

- Note:
- Dimensions are in millimeters [inches].
 - Connectors
 - J100 and J101: MMCX jack receptacle (Johnson P/ N 135-3701-201 or SAMTEC P/N RSP-149374-01 or equivalent)
 - P1500: 2x12 header, 2 mm pitch (SAMTEC P/ N TMM-112-03-G-D)
 - P1502: 2x8 header, 2 mm pitch (SAMTEC P/ N TMM-108-03-G-D)

Figure 75: OEM628 Keep-Out Zone

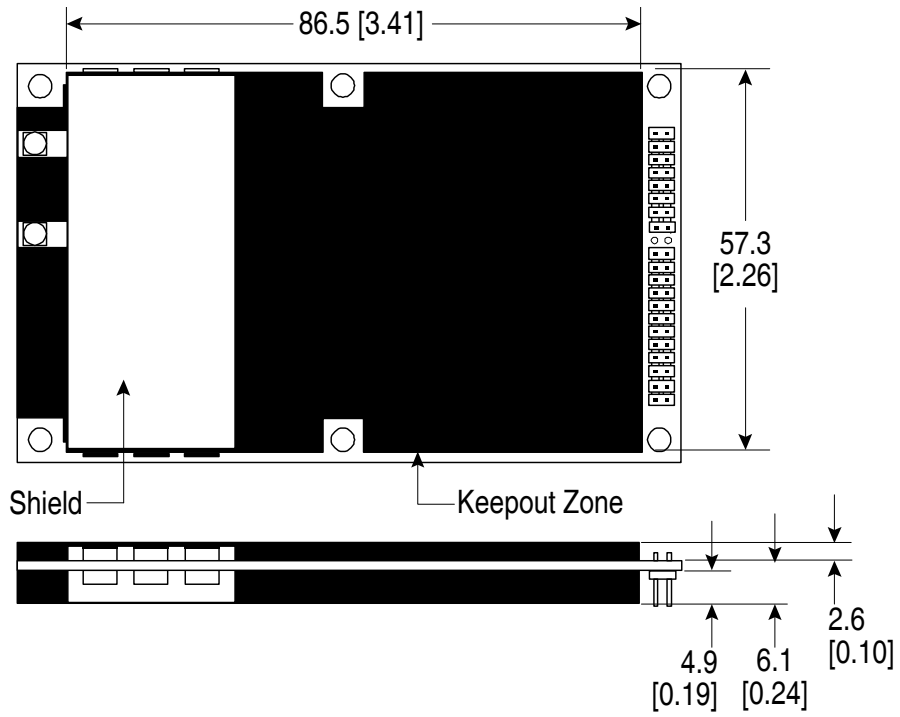

Note:

1. Dimensions are in millimeters [inches].
2. Keep-out areas are intended for NovAtel circuitry.

Figure 76: OEM628V Board Dimensions

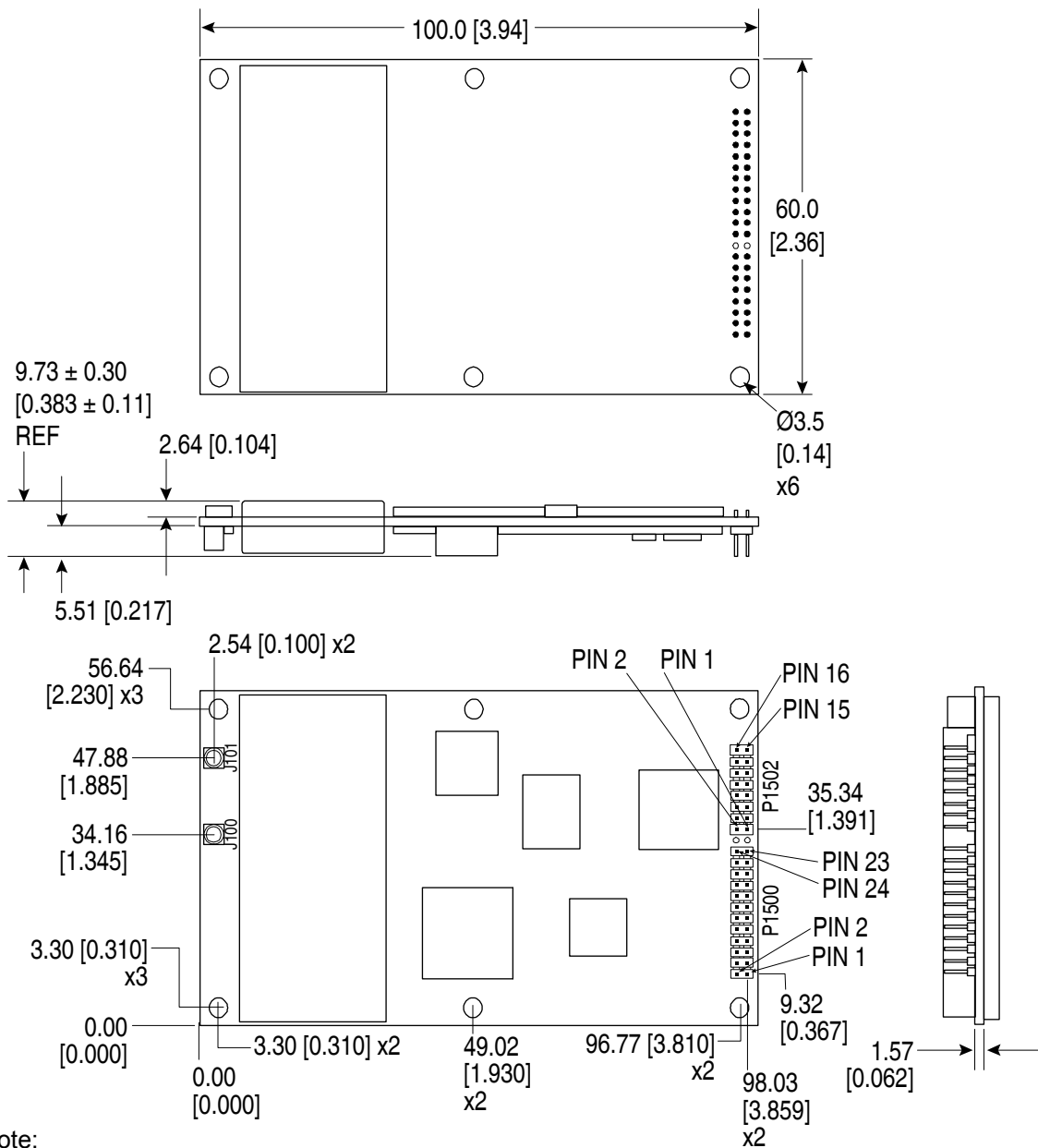

Note:

1. Dimensions are in millimeters [inches].
2. Connectors:
 - (a) J100 and J101 MMCX jack receptacle, straight (Johnson P/N 135-3701-201 or SAMTEC P/N RSP-149374-01 or equivalent)
 - (b) P1500: 2x12 header, 2 mm pitch (SAMTEC P/N TMM-112-03-G-D)
 - (c) P1502: 2x8 header, 2 mm pitch (SAMTEC P/N TMM-108-03-G-D)

Figure 77: OEM628V Keep-Out Zone

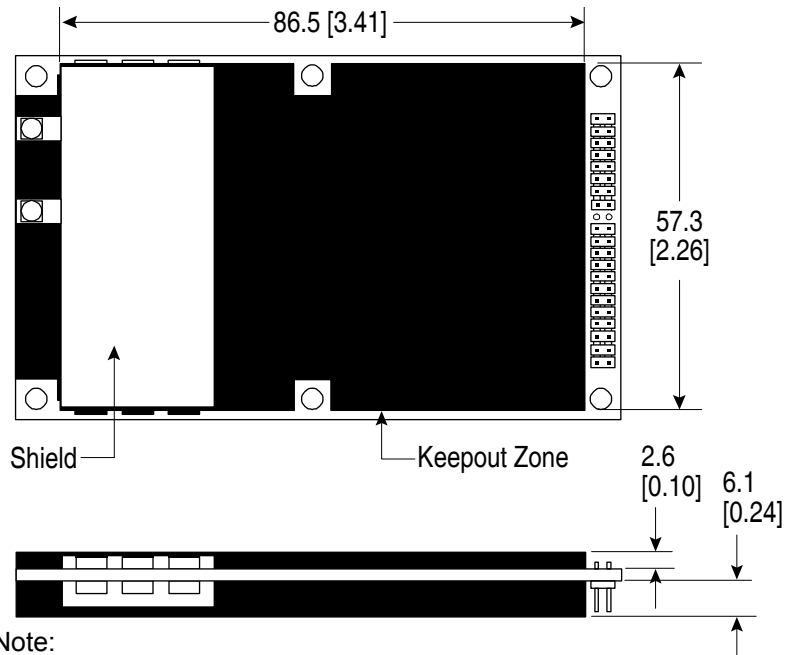

Note:

1. Dimensions are in millimeters [inches].
2. Keep-out areas are intended for NovAtel circuitry.

ENVIRONMENTAL	
Operating Temperature	-40°C to +85°C
Storage Temperature	-40°C to +85°C
Humidity	MIL-STD-810G, Method 507.5, Procedure II (95%)
Random Vibration	MIL-STD 810G, Method 514.6, Category 24 (7.7 g RMS)
Random Vibration (OEM628V only)	MIL-STD 810G, Method 514.6, Category 24 (20 g RMS)
Sinusoidal Vibration	IEC 60068-2-6
Bump	ISO 9022-31-06 (25 g)
Shock	Operating: MIL-STD-810G, Method 516.6, Procedure I (40 g) Non-operating: MIL-STD-810G, Method 516.6 Procedure V (1000 g)
Acceleration	MIL-STD-810G, Method 513.6, Procedure II (4 g, 8 g, 12 g, 16 g)
POWER REQUIREMENTS	
Voltage	+3.3 VDC ±5%
Allowable Input Voltage Ripple	100 mV p-p maximum
Power Consumption	<p>1.3 W typical, GPS L1/L2 1.5 W typical, GPS L1/L2, GLONASS L1/L2 1.81 W typical, GPS L1/L2/L5, GLONASS L1/L2, (without L-Band) 1.84 W typical, GPS L1/L2, GLONASS L1/L2 (with L-Band) 1.9 W typical, GPS L1/L2/L5, GLONASS L1/L2, Galileo E1/E5a/E5b/E5, (without L-Band) 2.13 W typical, GPS L1/L2, GLONASS L1/L2, BDS B1/B2, (without L-Band) 2.3 W typical, GPS L1/L2/L5, GLONASS L1/L2, Galileo E1/E5a/E5b/E5, BDS B1/B2, (without L-Band)</p> <p> These power consumption values assume that Ethernet is disabled. Ethernet draws approximately 220 mw. If you require a reduced power consumption, turn off the Ethernet port as outlined in <i>Chapter 6, Ethernet Configuration</i> on page 86 and commands described in the OEM6 Family Firmware Reference Manual.</p> <p>The above values can change with the number of satellites in view and the firmware version. Use them as a guide for what you might expect but not as absolute values</p>
In-Rush Power Consumption	6.6 A for less than 60 μs (typical)

RF INPUT / LNA POWER OUTPUT	
Antenna Connector	MMCX female, 50 W nominal impedance (see <i>Figure 74, OEM628 Board Dimensions</i> on page 146)
Acceptable RF Input Level	L1: -122 to -87 (signal) dBm, -161 to -141 (noise) dBm/Hz L2: -126 to -93 (signal) dBm, -161 to -141 (noise) dBm/Hz L-Band: -125 to -102 (signal) dBm, -161 to -151 (noise) dBm/Hz L5/E5: -119 to -84 (signal) dBm, -161 to -141 (noise) dBm/Hz
RF Input Frequencies	GPS L1: 1575.42 MHz GPS L2: 1227.60 MHz GPS L5: 1176.45 MHz GLONASS L1: 1593-1610 MHz GLONASS L2: 1237-1253 MHz L-Band: 1525 to 1560 MHz Galileo E1: 1575.42 MHz Galileo E5a: 1176.45 MHz Galileo E5b: 1207.14 MHz Galileo E5: 1191.795 MHz BeiDou B1: 1561.098 MHz BeiDou B2: 1207.14 MHz
LNA Power	User selectable: • +5 VDC \pm 5% • 0-100 mA (supplied by card through center conductor of RF connector) • 3.3 VDC 0-200 mA
CONNECTORS	
MMCX female	Connections between the MMCX and an external oscillator, or interface board, must be impedance controlled. To accomplish this use 50 ohm coaxial cable and 50 ohm connectors.
External Clock input	Refer to the <code>EXTERNALCLOCK</code> command
Frequency	5 MHz or 10 MHz
Input Impedance	50 Ohm nominal
Input VSWR	<2:1
Signal Level	0 dBm minimum to +13.0 dBm maximum
Frequency Stability	\pm 0.5 ppm maximum
Wave Shape	Sinusoidal

INPUT/OUTPUT DATA INTERFACE	
COM1	
Electrical format	RS-232/RS-422
Bit rates ^a	2400, 4800, 9600 (default), 19200, 38400, 57600, 115200, 230400, 460800 or 921600 bps. See <i>Section 4.1.1, Serial Ports</i> on page 52
Signals supported	COM1_Tx, COM1_Rx, RTS and CTS
Electrostatic discharge protection	Yes
COM2	
Electrical format	LVTTL
Bit rates ^a	2400, 4800, 9600 (default), 19200, 38400, 57600, 115200, 230400, 460800 or 921600 bps. See <i>Section 4.1.1, Serial Ports</i> on page 52
Signals supported	COM2_Tx, COM2_Rx, RTS and CTS
Electrostatic discharge protection	No
COM3	
Electrical format	LVTTL ^{b c}
Bit rates ^a	2400, 4800, 9600 (default), 19200, 38400, 57600, 115200, 230400, 460800 or 921600 bps. See <i>Section 4.1.1, Serial Ports</i> on page 52
Signals supported	COM3_Tx and COM3_Rx
Electrostatic discharge protection	No
CAN BUS^D	
Electrical format	LVTTL (requires external CAN transceiver)
Bit rates	1 Mbps maximum. CAN Bus throughput is determined by slowest device on the bus
Signals supported	CAN1 and CAN2
USB	
Electrical format	Conforms to USB 2.0
Bit rates	Low (1.5 Mbps) and full speed (12 Mbps) USB
Signals supported	USB D (+), USB D (-)
ETHERNET	
Physical Layer	10/100BASE-T

- a. Baud rates higher than 115,200 bps are not supported by standard PC hardware. Special PC hardware may be required for higher rates, including 230400 bps, 460800 bps and 921600 bps. See *OEM6 Card Default Serial Port Configurations* on page 39 for details.
- b. Upon power-up, COM3 is enabled by default. COM3 is multiplexed with Event 2 and GPIOH(0)
- c. To enable EVENT2, issue the following commands:
`INTERFACEMODE COM3 NONE NONE`
`MARKCONTROL MARK2 ENABLE`
- d. CAN Bus behavior must be asserted through the NovAtel API software. See *CAN Bus (not available on the FlexPak6D)* on page 74 for further details. See also *Figure 78, Top-view, P1500 Main Connector 24-Pin Header* on page 154

Table 30: OEM628 Strobes

Strobes	Default Behavior	Input/ Output	Factory Default	Comment ^a
Event1	Dedicated pin	Input Leading edge triggered	Active low	An input mark for which a pulse greater than 150 ns triggers certain logs to be generated. (Refer to the MARKPOS and MARKTIME logs and ONMARK trigger.) Polarity is configurable using the MARKCONTROL command.
Event2 (Mark 2)	Multiplexed pin	Input Leading edge triggered	Active low	An input mark for which a pulse greater than 150 ns triggers certain logs to be generated. (Refer to the MARK2POS and MARK2TIME logs.) Polarity is configurable using the MARKCONTROL command.
PV (Position Valid)	Dedicated pin	Output	Active high	Indicates a valid GNSS position solution is available.
VARF (Variable Frequency)	Dedicated pin	Output	Active low	A programmable variable frequency output ranging from 0 – 100 MHz (refer to the FREQUENCYOUT command)
RESETIN	Dedicated pin	Input	Active low	Reset LVTTTL signal input from external system; active low, 50 ms duration. Hold the RESETIN pin low for >150 ms after power is applied
PPS	Dedicated pin	Output	Active low	A time synchronization output. This is a pulse where the leading edge is synchronized to receiver calculated GNSS Time. The polarity, period and pulse width can be configured using PPSCONTROL command

a. The commands and logs shown in capital letters (for example, MARKCONTROL) are discussed in further detail in the [OEM6 Family Firmware Reference Manual](#) (OM-20000129).

Table 31: OEM628 Strobe Electrical Specifications

Strobe	Sym	Min (V)	Typ (V)	Max (V)	Current (mA)	Conditions
Event1 (Mark 1) Event2 (Mark2)	V _{IL}			0.8		VCC = 3.3 V compatible; 85°C
	V _{IH}	2.0				
PPS PV VARF	V _{OL}			0.55	24	VCC = 3.3 V; 85°C
	V _{OH}	2.3			24	
RESETIN	V _{IL}			0.8		
	V _{IH}	2.0				

Figure 78: Top-view, P1500 Main Connector 24-Pin Header

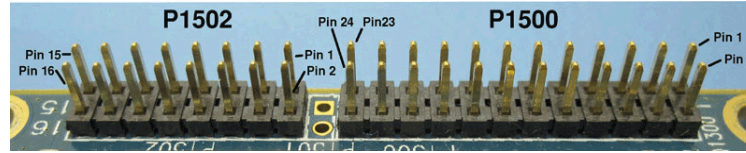

Pin	Signal	Type	Description	Comments
1	GND	GND	Ground Reference	–
2	USER1 ^a	Input/ Output	General Purpose I/O	2.7 V CMOS levels, 4 mA drive (3.3 V compatible)
3	VARF	Output	Variable Frequency	Refer to <i>Table 31, OEM628 Strobe Electrical Specifications</i> on page 153
4	PPS	Output	Time Mark Output, synchronous to GPS time	
5	VCC	PWR	+3.3 V Supply Voltage	±5%
6	VCC	PWR	+3.3 V Supply Voltage	±5%
7	RXD3/ EVENT2	Input	External Event 2/COM3 Receive Data	2.7 V CMOS levels (3.3 v compatible)
8	EVENT1	Input	External Event 1	2.7 V CMOS levels (3.3 v compatible)
9	ERROR	Output	Error Detected	2.7 V CMOS levels, 4 mA drive (3.3 V compatible)
10	PVALID	Output	Position Valid	Refer to <i>Table 31, OEM628 Strobe Electrical Specifications</i> on page 153
11	CTS2	Input	COM2 Clear to Send	2.7 V CMOS levels (3.3 V compatible)
12	RESETIN	Input	Hardware Reset	Internally pulled up. Active low reset – hold below 0.8 V for a minimum of 50 milliseconds
13	RTS2	Output	COM2 Request to Send	2.7 V CMOS levels, 4 mA drive (3.3 V compatible)
14	RXD2	Input	COM2 Receive Data	2.7 V CMOS levels (3.3 V compatible)
15	CTS1/RXD1-	Input	COM1 Clear to Send (RS-232)/ COM1 Receive Data- (RS-422)	CTS1: RS232 levels (±25 V tolerant) RXD1-: RS422 levels (2 V differential typical)
16	TXD2	Output	COM2 Transmit Data	2.7 V CMOS levels, 4 mA drive (3.3 V compatible)
17	RTS1/TXD1-	Output	COM1 Request to Send (RS-232)/ COM1 Transmit Data- (RS-422)	RTS1: RS232 levels (±5.4 V typical) TXD1-: RS422 levels (2 V differential typical)
18	RXD1/RXD1+	Input	COM1 Receive Data (RS-232)/ COM1 Receive Data+ (RS-422)	RXD1: RS232 levels (±25 V tolerant) RXD1+: RS422 levels (2 V differential typical)
19	TXD3/USER0	Input/ Output	General Purpose I/O/COM3 Transmit Data	2.7 V CMOS levels, 4 mA drive (3.3 V compatible)
20	TXD1/TXD1+	Output	COM1 Transmit Data (RS-232)/ COM1 Transmit Data+ (RS-422)	TXD1: RS232 levels (±25 V tolerant) TXD1+: RS422 levels (2 V differential typical)

Pin	Signal	Type	Description	Comments
21	D-	Input/Output	USB D-	90 Ω differential pair, 5 V tolerant
22	D+	Input/Output	USB D+	
23	GND	GND	Ground Reference	–
24	GND	GND	Ground Reference	–

- a. On power up, if pin 2 is LOW or not connected, COM1 is configured as RS-232. If pin 2 is high, COM1 is configured as RS-422 (refer to *OEM6 Card Default Serial Port Configurations* on page 39).

Figure 79: Top-view, P1502 Expansion 16-Pin Header

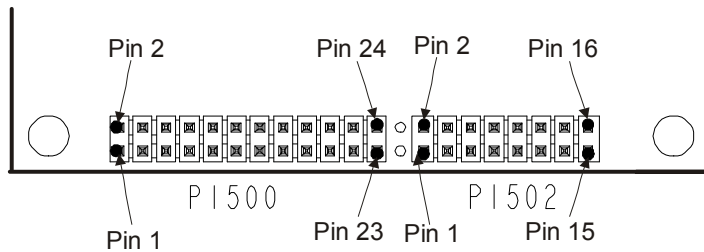

Pin	Signal	Type	Description
1	ETH_RD-	Input	Ethernet Rx-
2	ETH_RD+	Input	Ethernet Rx+
3	3V3 (for Ethernet magnetics center tap)	Output	Rx centre tap power for Ethernet magnetics
4	ETH_TD+	Output	Ethernet Tx+
5	ETH_TD-	Output	Ethernet Tx-
6	3V3 (for Ethernet magnetics center tap)	Output	Tx center tap power for Ethernet magnetics
7	LED_A	Output	Activity/Link
8	LED_B	Output	100 BT
9	GND	REF	GND
10	CAN1TX	Output	CAN1TX
11	CAN1RX	Input	CAN1RX
12	CAN2TX	Output	CAN2TX
13	CAN2RX	Input	CAN2RX
14	Reserved	Input	UID
15	VBUS	Input	VBUS
16	GND	REF	GND

D.1.2 CMOS Level I/O

The OEM628 provides a number of 2.7 V (3.3 V-compatible) CMOS level I/O pins for status indication and timing. These I/O include:

- PPS: Pulse-Per-Second (software configurable to other rates)
- VARF: Variable Frequency (a software configurable clock output)
- ERROR: Error indication
- PV: Position Valid (used to indicate when the receiver has calculated a valid position)
- EVENT1 and EVENT2: Event inputs (active high by default with configurable polarity)
- USERIO0 and USERIO1: User GPIO (available through NovAtel's API)

These I/O require additional ESD protection if they are routed to connectors. Some users may require additional drive strength on the PPS signal. The figure below shows a suitable buffer that may be used. R103 in the schematic may be used to limit the drive strength of the PPS output if required. This buffer has a propagation delay of approximately 5 to 6 nanoseconds.

The same ESD protection circuit shown below should be used on any OEM628 CMOS level signal that will be routed to an enclosure connector. The ferrite bead and small value capacitor provide some immunity to electrostatic discharge events, but also serve to reduce radiated and conducted emissions from the enclosure.

Figure 80: OEM628 ESD Protection for EVENT and PPS Strobes Schematic

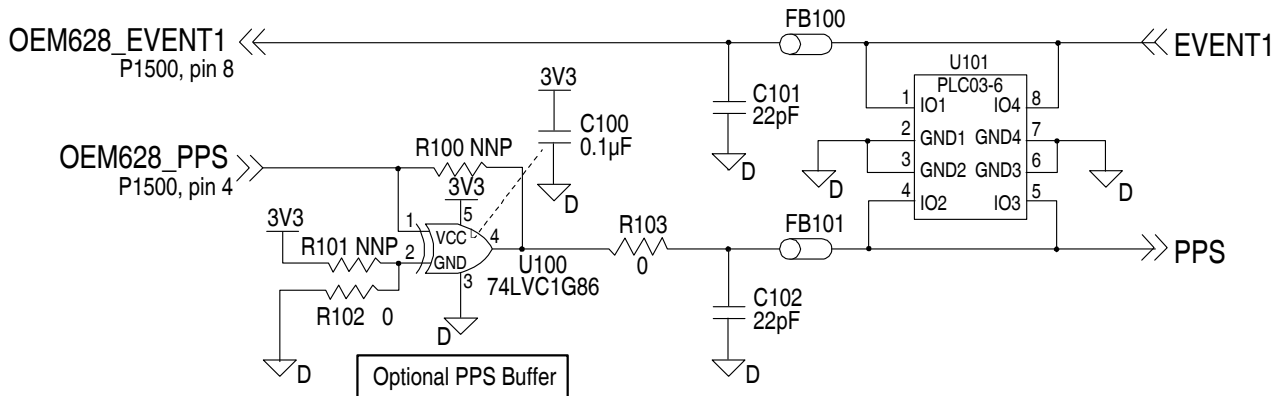
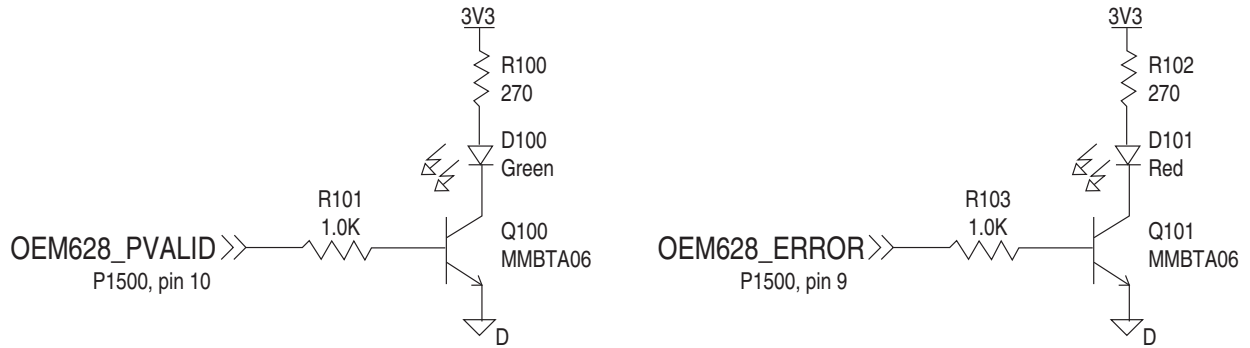

Table 32: ESD Critical Components

Designator	Manufacturer	Manufacturer Part Number
FFB100, FB101	TDK	MMZ1005B800C
U100	Texas Instruments	SN74LVC1G86DCK
U101	Semtech	LC03-6.TBT
	Bourns	CDNBS08-PLC03-6
	OnSemi	LC03-6R2G
C101, C102	various	(22 pF 5% 50V COG 0603)

The ERROR and PV signals are generally used on enclosure products to control a status LED. These signals have low drive strengths and require a buffer to drive an LED. A simple buffer circuit is shown below.

Figure 81: OEM628 LED Drive Buffer for ERROR and PV Signals Schematic



D.1.3 CAN Interface

The OEM628 provides two 2.7 V (3.3 V-compatible) CMOS level CAN controller ports. An external transceiver is required. The following figure shows a typical CAN transceiver implementation.

The combination of ferrite beads and small value capacitors are not necessarily required but may provide improved EMI performance. A low capacitance TVS device provides ESD protection.

Figure 82: OEM628 CAN Transceiver Implementation Schematic

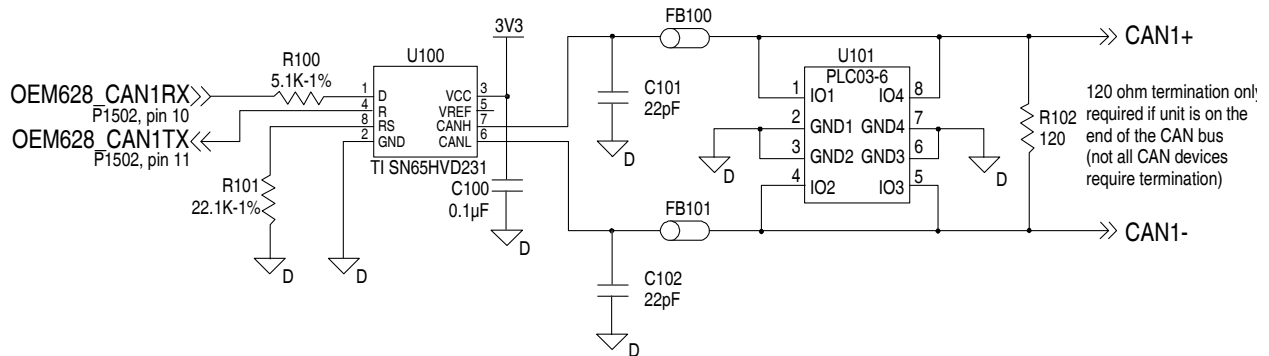

Only use a 120 Ω termination resistor when the CAN device is used at one end of the CAN bus. Multiple terminations along the length of the CAN bus will degrade performance for all CAN devices on that bus.

The slew rate adjustment resistor (R101) value in *Figure 82, OEM628 CAN Transceiver Implementation Schematic* on page 157 sets the slew rate for applications for SAE J1939 agricultural applications. Other applications may require a different slew rate. Refer to the transceiver data sheet for more information.

Table 33: CAN Critical Components

Designator	Manufacturer	Manufacturer Part Number
FB100, FB101	TDK	MMZ1005B800C
U100	Texas Instruments	SN74LVC1G86DCK
U101	Semtech	LC03-6.TBT
	Bourns	CDNBS08-PLC03-6
	OnSemi	LC03-6R2G
C101, C102	various	(22 pF 5% 50V COG 0603)

D.1.4 USB Interface

The OEM628 includes one USB 2.0 full speed (12 Mbps) / low speed (1.5 Mbps) interface.

For signal integrity and EMI reasons, route differential data traces as a 90 Ω differential pair. A small value common mode choke (as shown in the figure below) may improve the radiated emissions performance. Small ferrite beads are shown on VBUS and UID lines as a contingency against radiated emissions.

As long as the 90 Ω impedance is maintained while routing the USB D+/D- signals, no matching resistors are required. The pull resistors for mode selection are part of the USB PHY on the receiver card (no external pull resistors are required on the data lines to set host or device modes).

There is an ESD protection device on the receiver card for the USB differential pair. An additional device may be added near the USB connector but care should be taken not to cause a mismatch on the differential pair—stubs or large capacitance ESD protection should be avoided.

The OEM628_VBUS trace should be capable of handling at least 100 mA. The traces for VBUS and UID should be routed away from any high current switching nets and high frequency signals. The common mode choke, ferrite beads and bypass capacitor should be placed as close as possible to the USB connector.

When the USB interface is used as a device, the UID (pin 14) may be omitted (left as a no connect) and a standard USB Type-B connector used.

Table 34: USB Critical Components

Designator	Manufacturer	Manufacturer Part Number
L100	Steward / Laird	CM0805C221R-10

Figure 83: OEM628 USB Implementation Schematic

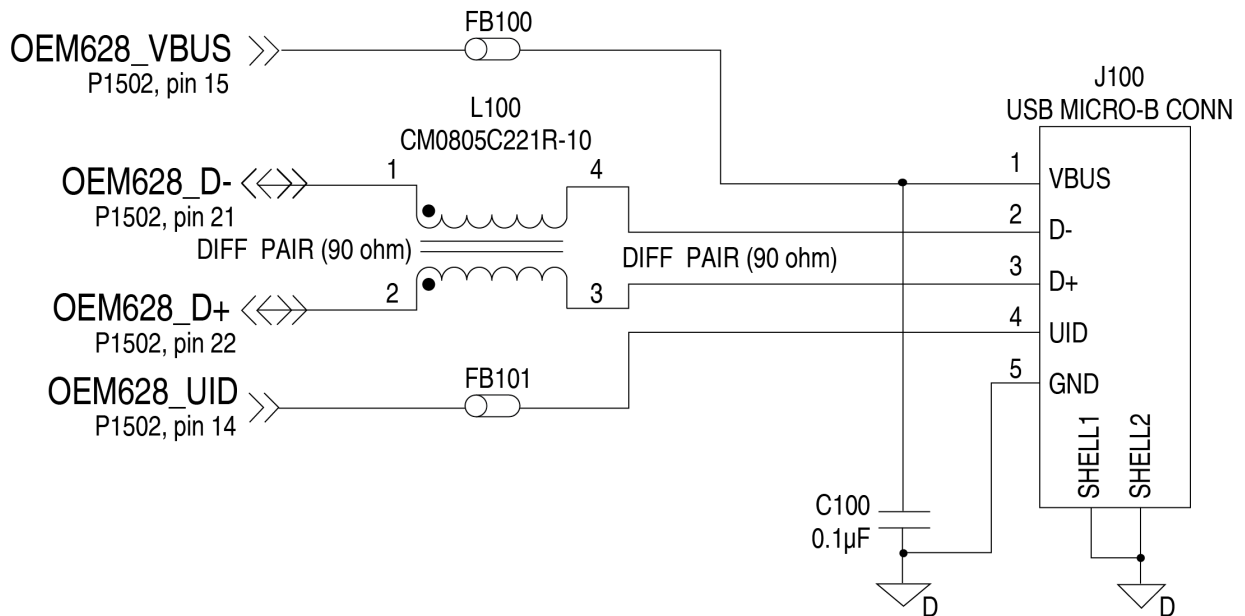

ESD protection for the differential pair is provided by a low capacitance TVS device located on the OEM628 card. External ESD protection for the UID and VBUS pins is required if the pins are used.

D.1.5 Ethernet Port

The OEM628 provides a 10/100 Ethernet port with auto-negotiation. The Ethernet interface is disabled by default and must be configured. See the [OEM6 Family Firmware Reference Manual](#) (OM-20000129) for instructions on Ethernet device configuration. The PHY layer is based on the Micrel KSZ8851 Ethernet controller.

PHY terminations are provided on the OEM628 card and a 3.3 V output is presented to bias the Ethernet magnetics. The 3.3 V power supplied by the OEM628 card is not to be used for any purposes other than biasing the Ethernet magnetics.

A reference schematic is shown below. The ferrite beads are included as an EMI de-risk contingency and may not be necessary.

Figure 84: Ethernet Reference Schematic

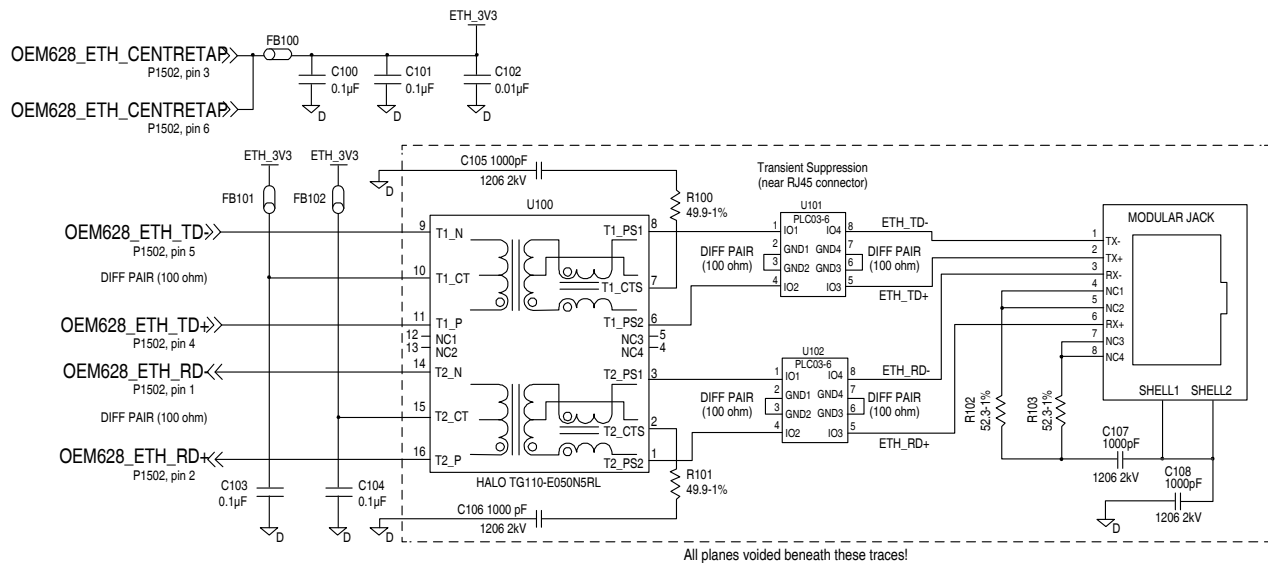

You must provide $100\ \Omega \pm 10\%$ differential pairs over unbroken reference (ground) planes up to the pins on the Ethernet magnetics. Beneath and beyond the magnetics, there must be no ground plane (no copper on layers other than the traces shown here). Ensure that the Ethernet differential pairs in the voided area are also $100\ \Omega \pm 10\%$ (the widths/spacing are different).

The transient suppression components must be placed as close to the RJ45 jack as possible. U101 and U102 protect the OEM628 against differential mode transients. The Ethernet magnetics provide high voltage isolation and low capacitance TVS devices on the OEM628 card itself protect against common mode transients.

The spacing between receive and transmit pairs should be at least three times the width of each differential pair (both traces plus the separation distance) to minimize crosstalk. Avoid more than two layer changes (single layer routing is best) and ensure that reference planes do not change when changing layers. If in doubt, contact your PCB vendor for appropriate dimensions for the differential pairs.

Keep vias on the lines to a minimum (ideally, no vias). If a layer change is required, ensure that the reference plane does not change to prevent increased radiated or conducted emissions.

Ethernet cable type (Cat5/Cat5e/Cat6) does not affect the OEM628 emissions profile with a properly laid out PCB. The following table gives recommended Ethernet transformer characteristics.

Alternately, use modular jacks with built-in Ethernet magnetics. In that case, run 100 Ω differential pairs over unbroken reference planes directly to the jack. Ensure the integrated magnetics in the jack meet the specifications in the table below. Ensure that the jack is no more than 15 cm (6 inches) from the OEM6 connector. Shorter runs are better.

Ethernet cable type (Cat5/Cat5e/Cat6) does not affect the OEM628 emissions profile with a properly laid out PCB. The following table gives recommended Ethernet transformer characteristics.

An example of a modular jack with integrated Ethernet magnetics is provided in *Figure 84, Ethernet Reference Schematic* on page 159. The part and circuit shown there would be suitable for the OEM628 as well. It is worth noting, however, that environmentally-sealed versions of the jack with integrated magnetics may not be readily available.

Table 35: Ethernet Transformer Characteristics

Parameter	Value	Test Condition
Turns ratio	1 CT : 1 CT	
Open-CCT inductance (minimum)	350 μ H	100 mV, 100 kHz, 8 mA
Leakage inductance (maximum)	0.4 μ H	1 MHz (minimum)
Inter-winding capacitance (minimum)	12 pF	
DC resistance (maximum)	0.9 Ω	
Insertion loss (maximum)	1.0 dB	0 MHz – 65 MHz
HIPOT (minimum)	1500 Vrms	

Table 36: Bill of Materials (critical components)

Designator	Manufacturer	Manufacturer Part Number
FFB100, FB101, FB102	TDK	MMZ1005B800C
U100	Halo	TG110-E050N5RL
U101, U102	Semtech Bourns OnSemi	LC03-6.TBT CDNBS08-PLC03-6 LC03-6R2G
C105, C106, C107	AVX	1206GC102KAT1A

The OEM628 Ethernet LED control lines must be buffered. The buffer structure in the figure below shows a sample LED drive circuit. Do not use the Ethernet bias 3.3 V (P1502, pins 3 and 6) to drive the LEDs. The Ethernet bias should only be routed to the Ethernet magnetics.

Figure 85: Ethernet LED Buffer Schematic

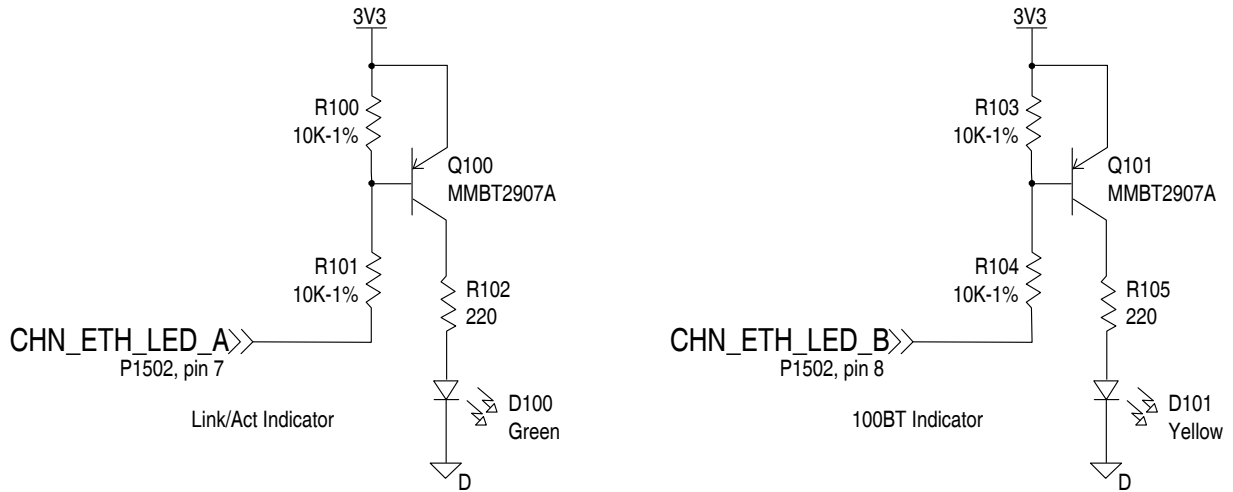

E.1 OEM638 Receiver **638**

PERFORMANCE (SUBJECT TO GPS SYSTEM CHARACTERISTICS)					
Position Accuracy ^a	Single point	L1 only	1.5 m RMS		
		L1/L2	1.2 m RMS		
	NovAtel CORRECT	SBAS ^b	0.6 m RMS		
		DGPS	0.4 m RMS		
		PPP ^{cd}	4 cm RMS		
	RTK	1 cm + 1 ppm RMS			
Time to First Fix	Hot: <35 s (Almanac and recent ephemeris saved and approximate position and time entered) Cold: <50 s (No almanac or ephemeris and no approximate position or time)				
Reacquisition	0.5 s L1 (typical) 1.0 s L2 (typical) 1.0 s L5 (typical)				
Data Rates	Measurements	100 Hz			
	Position	100 Hz			
Time Accuracy ^{ae}	20 ns RMS				
Velocity Accuracy ^a	0.03 m/s RMS				
Measurement Precision		GPS		GLO	
		Code	Carrier	Code	Carrier
	L1 C/A	4 cm	0.5 mm	8 cm	1.0 mm
	L2 P(Y) ^f	8 cm	1.0 mm	8 cm	1.0 mm
	L2C ^g	8 cm	0.5 mm	8 cm	1.0 mm
	L5	3 cm	0.5 mm	-	-
Dynamics	Velocity	515 m/s ^h			

a. Typical values. All position and velocity RMS values are based on Horizontal position accuracy. Performance specifications are subject to GPS system characteristics, U.S. DOD operational degradation, ionospheric and tropospheric conditions, satellite geometry, baseline length and multipath effects.

b. GPS-only.

c. Requires a TerraStar subscription which is available direct from NovAtel www.novatel.com/products/novatel-correct-ppp.

d. Performance dependent on local observing conditions.

e. Time accuracy does not include biases due to RF or antenna delay.

f. L2 P for GLONASS

g. L2 C/A for GLONASS

h. In accordance with export licensing.

E.1.1 Physical Description

PHYSICAL	
Weight	84 grams
Size	85 x 125 14.3 mm
NOVATEL PART NUMBERS	
Generic Assembly OEM638	01018727
MECHANICAL DRAWINGS	

Figure 86: OEM638 Dimensions

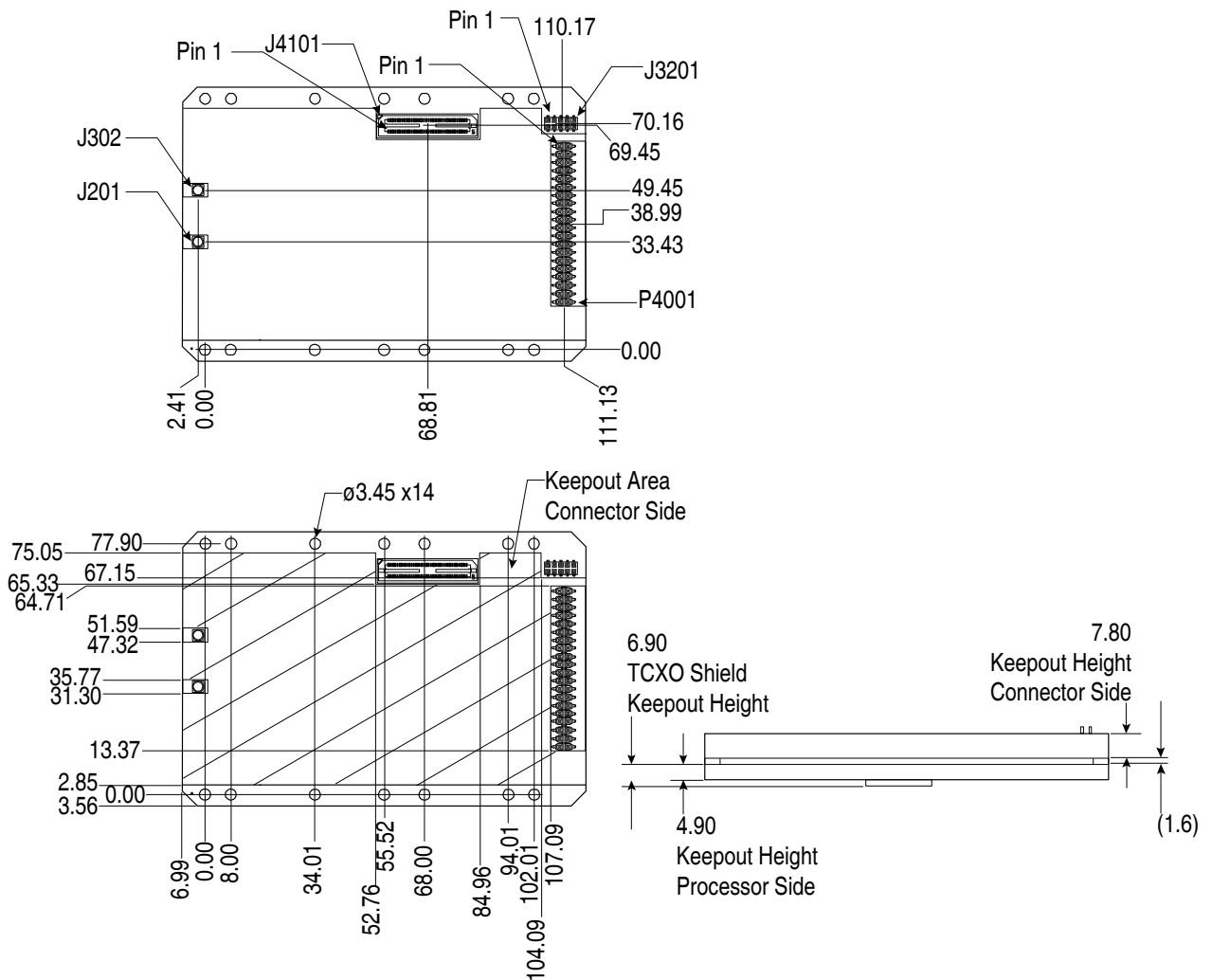

Notes:

1. Dimensions are in millimeters

2. CONNECTORS

(a) J201, J302: MMCX receptacle (Johnson P/N 135-3711-201 or 135-3711-202 or equivalent)

(b) J3201: 2X5 receptacle, 2 mm pitch (SAMTEC P/N SQW-105-01-L-D-VS-K-A or equivalent)

(c) P4001: 2X20 header, 0.1" pitch (SAMTEC P/N TSM-120-01-S-DV-A-P)

(d) J4101: 2X50 receptacle, 0.5 mm pitch (SAMTEC P/N BSH-050-01-L-D-A)

Figure 87: OEM638 and OEM638V Keep-Out Zone

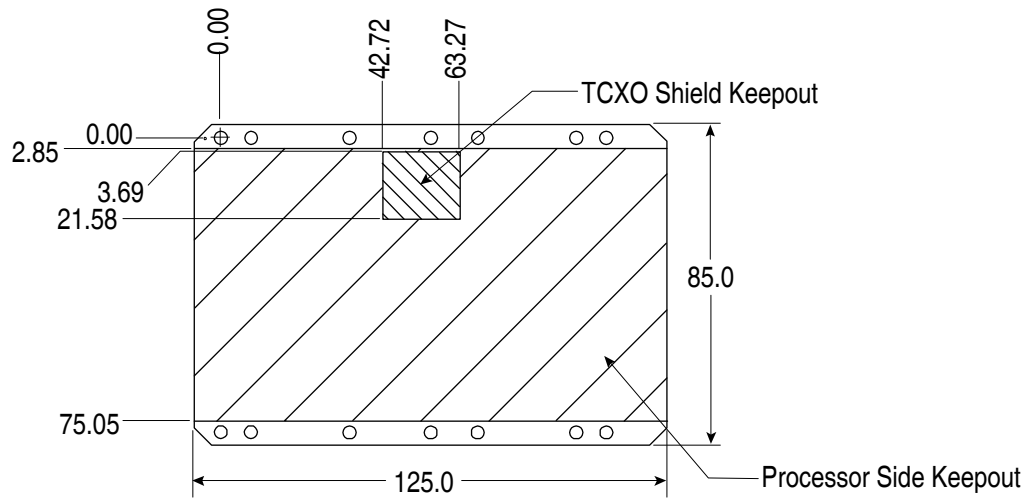

Notes:

1. Dimensions are in millimeters [inches].
2. Keep-out areas are intended for NovAtel circuitry.

ENVIRONMENTAL	
Operating Temperature	-40°C to +85°C
Storage Temperature	-40°C to +95°C
Humidity	MIL-STD-810G, Method 507.5, Procedure II (95%)
Random Vibration	MIL-STD 810G, Category 24 (20 Hz to 2000 Hz, 7.7 g RMS) and MIL-STD-810G, Method 514.6, Category 4 (5 Hz to 500 Hz, 2.3 g RMS)
Random Vibration (OEM638V only)	MIL-STD 810G, Category 24 (20 Hz to 20000 Hz, 20 g RMS) and MIL-STD-810G, Method 514.6, Category 4 (5 Hz to 500 Hz, 2.3 g RMS)
Sinusoidal Vibration	IEC 60068-2-6 (10 Hz to 2 kHz, 5 g)
Bump	ISO 9022-31-06 (25 g)
Shock	Operating - MIL-STD-810G, Method 516.6, Procedure I (40 g) Non-operating - MIL-STD-810G, Method 516.6, Procedure V (75 g)
Acceleration	MIL-STD-810G, Method 510.6, Procedure II (4 g, 8 g, 12 g, 16 g)
POWER REQUIREMENTS	
Voltage	Normal Mode: +3.3 VDC +5%/-3% OEMV3 Compatibility Mode (power via main header): +4.5 VDC to 36 VDC For best performance, NovAtel strongly recommends additional supply bypassing as close as possible to the OEM638 supply pins. For the 3.3V supply - minimum 22 uF in parallel with 0.1 μF For the wide-range supply - minimum 44 uF in parallel with 0.1 μF
Allowable Input Voltage Ripple	100 mV p-p maximum
Power Consumption	2.65 W typical, GPS L1/L2/GLONASS L1/L2/BDS B1/B2 2.8 W typical, GPS L1/L2 3.0 W typical, GPS/GLONASS L1/L2 3.1 W typical, GPS L1/L2/L5, GLONASS L1/L2, (without L-Band) 3.1 W typical, GPS L1/L2, GLONASS L1/L2 (with L-Band) 3.3 W typical, all on (without L-Band)  Power consumption values assume Ethernet is disabled. Ethernet draws approximately 450 mW. If reduced power consumption is required, turn off the Ethernet port as outlined in <i>Chapter 6, Ethernet Configuration</i> on page 86 and the ETHCONFIG command described in the OEM6 Family Firmware Reference Manual (OM-20000129) The above values can change with the number of satellites in view and the firmware version. Use only as a guide and not as absolute values
In-Rush Power Consumption	12.0 A for less than 60 μs (typical)

RF INPUT / LNA POWER OUTPUT	
Antenna Connector	MMCX female, 50 W nominal impedance (see <i>Figure 86, OEM638 Dimensions</i> on page 163)
Acceptable RF Input Level	L1: -122 to -87 (signal) dBm, -161 to -141 (noise) dBm/Hz L2: -126 to -93 (signal) dBm, -161 to -141 (noise) dBm/Hz L-Band: -125 to -102 (signal) dBm, -161 to -151 (noise) dBm/Hz L5/E5: -119 to -84 (signal) dBm, -161 to -141 (noise) dBm/Hz
RF Input Frequencies	GPS L1: 1575.42 MHz GPS L2: 1227.60 MHz GPS L5: 1176.45 MHz GLONASS L1: 1593-1610 MHz GLONASS L2: 1237-1253 MHz Galileo E1: 1575.42 MHz Galileo E5a: 1176.45 MHz Galileo E5b: 1207.14 MHz Galileo E5: 1191.795 MHz BeiDou B1: 1561.098 MHz BeiDou B2: 1207.14 MHz L-Band: 1525 to 1560 MHz
LNA Power	Voltage user selectable: +3.3 VDC \pm 10% or +5 VDC \pm 10% current 0-200 mA maximum (supplied by card through center conductor of RF connector)
CONNECTORS	
MMCX female	Connections between the MMCX and an external oscillator, or interface board, must be impedance controlled. To accomplish this use 50 ohm coaxial cable and 50 ohm connectors.
External Clock input	Refer to the EXTERNALCLOCK command
Frequency	5 MHz or 10 MHz
Input Impedance	50 Ohm nominal
Input VSWR	<2:1
Signal Level	0 dBm minimum to +13.0 dBm maximum
Frequency Stability	\pm 0.5ppm maximum
Wave Shape	Sinusoidal

INPUT/OUTPUT DATA INTERFACE	
COM1	
Electrical format	RS-232/RS-422 ^a
Bit rates ^b	2400, 4800, 9600 (default), 19200, 38400, 57600, 115200, 230400, 460800 or 921600 bps. See <i>Section 4.1.1, Serial Ports</i> on page 52
Signals supported	TXD1, RXD1, RTS1 and CTS1
Electrostatic discharge protection	Yes
COM2	
Electrical format	RS-232/RS-422
Bit rates ^b	2400, 4800, 9600 (default), 19200, 38400, 57600, 115200, 230400 or 460800. See <i>Section 4.1.1, Serial Ports</i> on page 52
Signals supported	TXD2 RXD2, RTS2, CTS2, DTR2, DCD2
Electrostatic discharge protection	Yes
COM3	
Electrical format	LVTTTL
Bit rates ^b	2400, 4800, 9600 (default), 19200, 38400, 57600, 115200, 230400, 460800 or 921600 bps. See <i>Section 4.1.1, Serial Ports</i> on page 52
Signals supported	TXD3, RXD3, RTS3, CTS3
Electrostatic discharge protection	Yes
COM4	
Electrical format	LVTTTL
Bit rates ^b	2400, 4800, 9600 (default), 19200, 38400, 57600, 115200, 230400, 460800 or 921600 bps. See <i>Section 4.1.1, Serial Ports</i> on page 52
Signals supported	TXD4, RXD4, RTS4, CTS4
Electrostatic discharge protection	Yes
COM5	
Electrical format	LVTTTL
Bit rates ^b	2400, 4800, 9600 (default), 19200, 38400, 57600, 115200, 230400, 460800 or 921600 bps. See <i>Section 4.1.1, Serial Ports</i> on page 52
Signals supported	TXD5, RXD5, RTS5, CTS5
Electrostatic discharge protection	Yes

IMUCOM (COM6)	
Electrical format	RS-232/RS-422
Bit rates ^b	2400, 4800, 9600 (default), 19200, 38400, 57600, 115200, 230400, 460800 or 921600 bps. See <i>Section 4.1.1, Serial Ports</i> on page 52
Signals supported	IMUTXD, IMURXD, IMURTS and IMUCTS
Electrostatic discharge protection	Yes
CAN BUS^c	
Electrical format	CAN
Bit rates	1 Mbps maximum. CAN Bus throughput is determined by slowest device on the bus
Signals supported	CAN1(+), CAN1(-) and CAN2(+), CAN2(-)
USB0 (DEVICE ONLY)	
Electrical format	USB 2.0 high speed device
Bit rates	Full speed (12 Mbps) USB, High speed (480 Mbps)
Signals supported	USB D (+), USB D (-)
USB1 (HOST ONLY)	
Electrical format	Conforms to USB 2.0
Bit rates	High speed (480 Mbps)
Signals supported	USB D (+), USB D (-) VBUS (with control for external VBUS switch)
USB2 (HOST ONLY)	
Electrical format	USB high speed host
Bit rates	High speed (480 Mbps)
Signals supported	USB D (+), USB D (-) VBUS (with control for external VBUS switch)
ETHERNET	
Physical Layer	10/100BASE-T

- a. On power up, if USERIO1 (pin30) is pulled LOW or not connected, COM1 will be configured as RS-232 at boot. If USERIO1 (pin 30) is pulled high, then COM1 will be configured as RS-422 at boot (as described in *Section 4.1.1, Serial Ports* on page 52).
- b. Baud rates higher than 115,200 bps are not supported by standard PC hardware. Special PC hardware may be required for higher rates, including 230400 bps, 460800 bps and 921600 bps. See *Section 4.1.1, Serial Ports* on page 52 and *Table 4, OEM6 Card Default Serial Port Configurations* on page 39 for details.
- c. CAN Bus behavior must be asserted through the NovAtel API software. See *Section 4.10.2, CAN Bus (not available on the FlexPak6D)* on page 74 for further details. See also *Figure 90, J4101 Expansion Header Pin-Out and Signal Description (odd numbered pins)* on page 175 along with the table.

Table 37: OEM638 Strobes

Strobes	Default Behavior	Input/Output	Factory Default	Comment ^a
Event_In1 (Mark 1)	Dedicated pin	Input Leading edge triggered	Active low	An input mark for which a pulse greater than 150 ns triggers certain logs to be generated. (Refer to the MARKPOS and MARKTIME logs and ONMARK trigger.) Polarity is configurable using the MARKCONTROL command. The mark inputs have pull-up resistors to 3.3 V
nRESET_OUT/ Event_In2 (Mark 2)	Multiplexed pin	Input Leading edge triggered	Active low	By default, this pin is the nRESET_OUT output. Software configurable to EVENT_IN2. An input mark for which a pulse greater than 150 ns triggers certain logs to be generated. (Refer to the MARK2POS and MARK2TIME logs.) Polarity is configurable using the MARKCONTROL command. The mark inputs have pull-up resistors to 3.3 V
Event_In3 (Mark 3)	Dedicated pin	Input Leading edge triggered	Active low	An input mark for which a pulse greater than 150 ns triggers certain logs to be generated. (Refer to the MARK3POS and MARK3TIME logs.) Polarity is configurable using the MARKCONTROL command. The mark inputs have pull-up resistors to 3.3 V
Event_In4	Multiplexed pin	Input Leading edge triggered	Active low	An input mark for which a pulse greater than 150 ns triggers certain logs to be generated. (Refer to the MARK4POS and MARK4TIME logs.) Polarity is configurable using the MARKCONTROL command. The mark inputs have pull-up resistors to 3.3 V
PV (Position Valid)	Dedicated pin	Output	Active high	Indicates a valid GNSS position solution is available.
VARF (Variable Frequency)	Dedicated pin	Output	Active low	A programmable variable frequency output ranging from 0.1 Hz–50 MHz (refer to the FREQUENCYOUT command) Also called EVENT_OUT1 (refer to the EVENTOUTCONTROL command)
RESETIN	Dedicated pin	Input	Active low	Reset LVTTTL signal input from external system; active low, >50 µs duration
PPS	Dedicated pin	Output	Active low	A time synchronization output. This is a pulse where the leading edge is synchronized to receiver calculated GNSS Time. The polarity, period and pulse width can be configured using PPSCONTROL command
PV/Event_Out3	Multiplexed pin	Output	Active high	By default this output indicates the PV state (same as "PV" above). Software configurable to output EVENT_OUT3
EVENT_OUT2, 4, 5, 6, 7	Dedicated pin	Output		A programmable variable frequency output ranging from 1Hz to 50MHz (refer to the EVENTOUTCONTROL command)

a. The commands and logs shown in capital letters (for example, MARKCONTROL) are discussed in further detail in the [OEM6 Family Firmware Reference Manual](#) (OM-20000129).

Table 38: OEM638 Strobe Electrical Specifications

Strobe	Sym	Min (V)	Max (V)	Current (mA)	Conditions
Event_In1 (Mark1)	V_{IL}		0.8		VCC = 3.3 V; 85°C
Event_In2 (Mark2)	V_{IH}	2.0			VCC = 3.3 V; 85°C
Event_In3 (Mark3)					
Event_In4 (Mark4)					
Event_Out2	V_{OL}		0.4	24	VCC = 3.3 V; 85°C
Event_Out4	V_{OH}	3.0		24	VCC = 3.3 V; 85°C
Event_Out5					
Event_Out6					
Event_Out7					
PPS					
PV VARF					
RESETIN	V_{IL}		0.8		VCC = 3.3 V; 85°C
	V_{IH}	2.3			VCC = 3.3 V; 85°C



A number of pins on the OEM638 card can have multiple functions. Refer to the `IOCONFIG`, `EVENTINCONTROL` and `EVENTOUTCONTROL` commands in the [OEM6 Family Firmware Reference Manual](#) (OM-20000129) for details.

Figure 88: P4001 Main Header Pin-Out and Signal Description

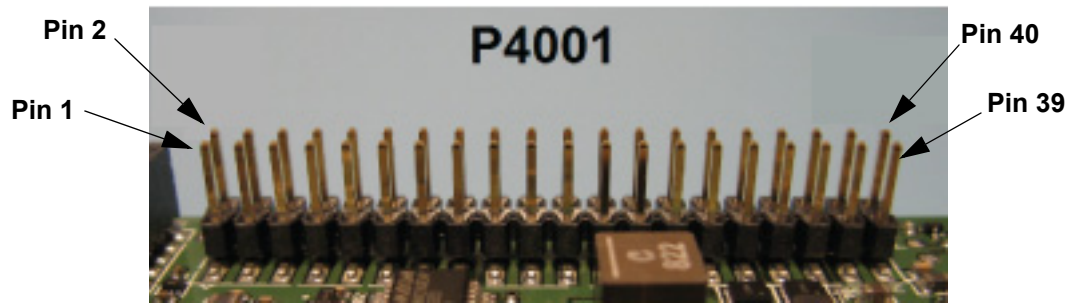

Pin	Signal Name	Signal Type	Signal Direction	Polarity	Drive Strength (mA)	Description
1	VIN	PWR	Input		-	Supply Input (4.5 V-36 VDC). The wide-range supply input on J4101 is preferred for new designs (as it has a higher max current rating).
2	PV	3.3V CMOS	Output	Active High	2	Position Valid Output. If high, indicates a valid GNSS position.
3	USB0_D+	Analog	IO		-	USB0 D+ (differential signal). USB0 supports 480/12/1.5Mbps data transfers.
4	GND	GND			-	
5	USB0_D-	Analog	IO		-	USB0 D-(differential signal). USB0 supports 480/12/1.5Mbps data transfers.
6	GND	GND			-	
7	PPS	3.3V CMOS	Output	Active High ^b	8	Pulse Per Second. Outputs one pulse per second, synchronized to GNSS time.
8	GND	GND	GND		-	
9	VARF (EVENT_OUT1)	3.3V CMOS	Output		8	Variable Frequency Output. Outputs a user specified timing signal. Can be synchronized with PPS. Weak pull up internal to OEM638
10	GND	GND	GND		-	
11	EVENT_IN1 (MKI)	3.3V CMOS	Input	Rising edge ^b	-	Mark Input. Transitions on this pin are time stamped and reported in logs (or used by application code).
12	GND	GND	GND		-	
13	STATUS_RED	3.3V CMOS	Output	Active High	2	Red Status LED Control. Used to indicate the state of the receiver or provide error codes.

Pin	Signal Name	Signal Type	Signal Direction	Polarity	Drive Strength (mA)	Description
14	CTS1 / RXD1-	RS232 / RS422	Input		-	CTS1: RS232 Flow Control (± 25 V tolerant) RXD1-: RS422 Signaling (2 V differential typical)
15	TXD1 / TXD1+	RS232 / RS422	Output		-	TXD1: RS232 Signaling (± 25 V tolerant) TXD1+: RS422 Signaling (2 V differential typical)
16	RTS1 / TXD1-	RS232 / RS422	Output		-	RTS1: RS232 Flow Control (± 25 V tolerant) TXD1-: RS422 Signaling (2 V differential typical)
17	RXD1 / RXD1+	RS232 / RS422	Input		-	RXD1: RS232 Signaling (± 25 V tolerant) RXD1+: RS422 Signaling (2 V differential typical)
18	CTS3	3.3V CMOS	Input		-	COM3 UART Signaling (3.3 V CMOS logic)
19	TXD3	3.3V CMOS	Output		2	COM3 UART Signaling (3.3 V CMOS logic)
20	DCD2	RS232	Input		-	DCD2: RS232 Flow Control (± 25 V tolerant)
21	RXD3	3.3V CMOS	Input		-	COM3 UART Signaling (3.3 V CMOS logic)
22	RTS3	3.3V CMOS	Output		2	COM3 UART Signaling (3.3 V CMOS logic)
23	DTR2	RS232	Output		-	DTR2: RS232 Flow Control (± 25 V tolerant)
24	CTS2 / RXD2-	RS232 / RS422	Input		-	CTS2: RS232 Flow Control (± 25 V tolerant) RXD2-: RS422 Signaling (2 V differential typical)
25	TXD2 / TXD2+	RS232 / RS422	Output		-	TXD2: RS232 Flow Control (± 15 V tolerant) TXD2+: RS422 Signaling (2 V differential typical)
26	RTS2 / TXD2-	RS232 / RS422	Output		-	RTS2: RS232 Flow Control (± 25 V tolerant) RXD2-: RS422 Signaling (2 V differential typical)
27	RXD2 / RXD2+	RS232 / RS422	Input		-	RXD2: RS232 Signaling (± 25 V tolerant) RXD2+: RS422 Signaling (2 V differential typical)
28	STATUS_GRN	3.3V CMOS	Output	Active High	2	Green Status LED Control. Used to indicate the state of the receiver or provide error codes.
29	USERIO0	3.3V CMOS	IO		2	General Purpose IO.
30	USERIO1 ^a	3.3V CMOS	IO		2	General Purpose IO.

Pin	Signal Name	Signal Type	Signal Direction	Polarity	Drive Strength (mA)	Description
31	EVENT_IN2 / USERIO2	3.3V CMOS	IO		2	General Purpose IO. Multiplexed with EVENT_IN2 (software selectable pin functions). Weak pull up internal to OEM638
32	MKO (EVENT_OUT2)	3.3V CMOS	Output	Rising Edge ^b	8	Mark Output. Outputs a user-specified timing signal. Can be synchronized with PPS
33	nRESET_IN	3.3V CMOS	Input	Active Low	-	Reset Input. Resets the OEM card when low. Minimum low time for reset is 1 us. This pin is pulled up internally (32 kΩ-100 kΩ).
34	GPAI0	Analog	Analog	--	-	General Purpose Analog Input. 0 - 3.3 V Input; sampled by internal 12-bit ADC.
35	_RESETOUT	3.3V CMOS	Output/ Input	Active Low	2	Reset Output. Normally high, is driven low shortly after the receiver is reset and remains low for approximately 140 ms. Weak pull up internal to OEM638
36	GND	GND	GND	--	-	
37	FR	3.3V CMOS	Input	--	-	Reserved. Do not use. 10 kohm pull down resistor internal to OEM638
38	ERROR/ EVENT_IN4	3.3V CMOS	Output/ Input	Active High	2	Error indicator/Multiplexed with EVENT_IN4 (software selectable pin functions)
39	5V	Power	Output	--	-	Onboard 5V supply. Here for legacy support only. This supply should be left floating unless used for reverse compatibility with the OEMV-3.
40	EXT_LNA_PWR	Power	Input	--	-	External LNA power supply input option. An external supply between 5.5 V and 18 VDC may be connected here if the internal 3.3 V and 5.0 V options are not suitable. Powers the GNSS antenna.

- a. On power up, if USERIO1 (pin 30) is pulled LOW or not connected, COM1 will be configured as RS-232 at boot. If USERIO1 (pin30) is pulled high, then COM1 will be configured as RS-422 at boot (as described in [OEM6 Family Firmware Reference Manual](#) (OM-20000129)).
- b. Software configurable. Default polarity is shown in table.



This connector mates with *Samtec SSW-120-01-G-D* (or similar). The standard mating height for the OEM638 card is 14 mm.

Figure 89: J3201 Ethernet Header Pin-Out and Signal Description

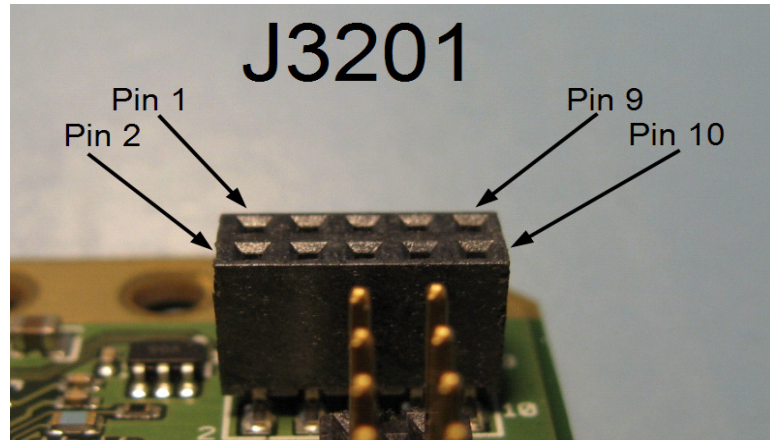

Pin	Signal Name	Signal Type	Signal Direction	Polarity	Drive Strength (mA)	Description
1	ETH_TX+	Analog	IO		-	Ethernet Transmit (100 Ω differential pair)
2	ETH_TX-	Analog	IO		-	Ethernet Transmit (100 Ω differential pair)
3	ETH_BIAS	PWR	Output		-	DC Bias source for the Ethernet magnetics
4	GND ^a	GND	-		-	
5	ETH_RX+	Analog	IO		-	Ethernet Receive (100 Ω differential pair)
6	ETH_RX-	Analog	IO		-	Ethernet Receive (100 Ω differential pair)
7	GND ^a	GND	-		-	
8	ETH_LED_ACT	3.3V Open Drain	Sink	Active Low	8	Ethernet “Activity” LED indicator. Connect to LED supplied from 3.3 V. Do not use the ETH_BIAS to supply the LED.
9	ETH_LED_SPD	3.3V Open Drain	Sink	Active Low	8	Ethernet “Speed” LED indicator. Connect to LED supplied from 3.3 V. Do not use the ETH_BIAS to supply the LED.
10	ETH_LED_LNK	3.3V Open Drain	Sink	Active Low	8	Ethernet “Link” LED indicator. Connect to LED supplied from 3.3 V. Do not use the ETH_BIAS to supply the LED.

a. Connect to the chassis ground through a bead or capacitor for best performance.



This connector mates with Samtec TW-05-03-G-D-240-090 (or similar). The standard mating height for the OEM638 card is 14 mm.

Figure 90: J4101 Expansion Header Pin-Out and Signal Description (odd numbered pins)

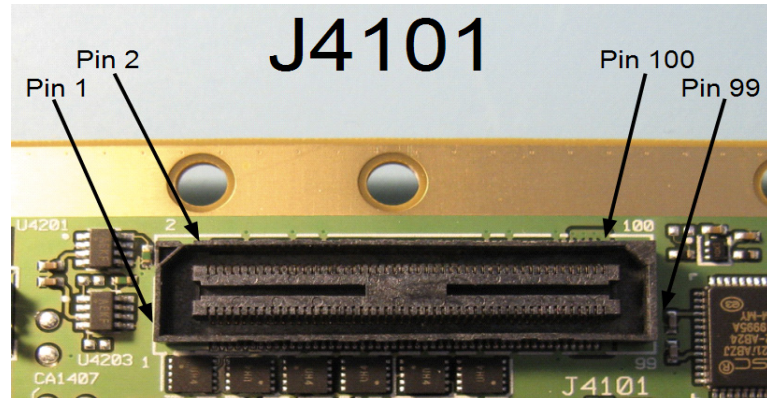

Pin	Signal Name	Signal Type	Signal Direction	Polarity	Drive Strength (mA)	Description
1	GND			-	-	
3	TXD4	3.3V CMOS	Output	-	2	COM4 UART Signaling (3.3 V CMOS logic)
5	RXD4	3.3V CMOS	Input	-	-	COM4 UART Signaling (3.3 V CMOS logic)
7	RTS4	3.3V CMOS	Output	-	2	COM4 UART Signaling (3.3 V CMOS logic)
9	CTS4	3.3V CMOS	Input	-	-	COM4 UART Signaling (3.3 V CMOS logic)
11	CAN1+	CAN	IO	-	-	CAN1+ Differential Signal
13	CAN1-	CAN	IO	-	-	CAN1- Differential Signal
15	CAN2+	CAN	IO	-	-	CAN2+ Differential Signal
17	CAN2-	CAN	IO	-	-	CAN2- Differential Signal
19	GND			-	-	
21	SPI1_nCS0	3.3V CMOS	Output	Active Low	2	Serial Peripheral Interface #1, Chip Select 0.
23	SPI1_SCLK	3.3V CMOS	Output	-	2	Serial Peripheral Interface #1, Serial Clock.
25	SPI1_MOSI	3.3V CMOS	Output	-	2	Serial Peripheral Interface #1, Master Out / Slave In
27	SPI1_MISO	3.3V CMOS	Input	-	-	Serial Peripheral Interface #1, Master In / Slave Out
29	SPI1_nCS1	3.3V CMOS	Output	Active Low	2	Serial Peripheral Interface #1, Chip Select 1.

Pin	Signal Name	Signal Type	Signal Direction	Polarity	Drive Strength (mA)	Description
31	SPI4_nCS0	3.3V CMOS	Output	Active Low	2	Serial Peripheral Interface #4, Chip Select 0.
33	SPI4_SCLK	3.3V CMOS	Output	-	2	Serial Peripheral Interface #4, Serial Clock.
35	SPI4_MOSI	3.3V CMOS	Output	-	2	Serial Peripheral Interface #4, Master Out / Slave In
37	SPI4_MISO	3.3V CMOS	Input	-	-	Serial Peripheral Interface #4, Master In / Slave Out
39	GND			-	-	
41	I2C2_SDA	Open Drain	IO	-	-	I ² C Interface #2, internally pulled to 3.3 V
43	I2C2_SCL	Open Drain	IO	-	-	
45	GND			-	-	
47	TXD5	3.3V CMOS	Output	-	2	COM5 UART Signaling (3.3 V CMOS logic)
49	RXD5	3.3V CMOS	Input	-	-	COM5 UART Signaling (3.3 V CMOS logic)
51	RTS5	3.3V CMOS	Output	-	2	COM5 UART Signaling (3.3 V CMOS logic)
53	CTS5	3.3V CMOS	Input	-	-	COM5 UART Signaling (3.3 V CMOS logic)
55	GND			-	-	
57	SDIO1_CMD	1.8V-3.0V MMC	Output	-	12	 These pins are NOT 3.3 V tolerant! Connection to 3.3 V signals will damage the receiver.
59	SDIO1_CLK	1.8V-3.0V MMC	Output	-	12	
61	SDIO1_DAT0	1.8V-3.0V MMC	IO	-	12	
63	SDIO1_DAT1	1.8V-3.0V MMC	IO	-	12	
65	SDIO1_DAT2	1.8V-3.0V MMC	IO	-	12	
67	SDIO1_DAT3	1.8V-3.0V MMC	IO	-	12	
69	GND			-	-	
71	HSUSB0_UID	USB	IO	-	-	USB0 IDentification. Leave floating for normal operation

Pin	Signal Name	Signal Type	Signal Direction	Polarity	Drive Strength (mA)	Description
73	HSUSB0_VBUS	USB	Input	-	-	Used by the card to monitor activity on the USB0 interface. This pin cannot supply current to hosted devices but must be connected for normal operation.
75	HSUSB2_VBUS	USB	Input	-	-	Used by the card to monitor activity on the USB2 interface. This pin cannot supply current to hosted devices but must be connected for normal operation.
77	HSUSB2_VBUS_EN	3.3V CMOS	Output	Active High	3	Control for an external 5 V power switch for USB2.
79	HSUSB2_D+	USB	IO	-	-	The differential data pair for USB2.
81	HSUSB2_D-	USB	IO	-	-	
83	Reserved					
85	Reserved					
87	3V3_nWIDE_SEL	3.3V CMOS	Input	-	-	Select the active power supply. If low, will enable the wide-range converter. If high, the card will operate from the 3.3 V supply input.
89	GND			-	-	
91	GND			-	-	
93	3V3_EXT	3.3V Supply Input		-	-	These pins may connect to an external 3.3 V power supply. If the 3V3_EXT supply is used, do not connect a supply to 4V5_36V_INPUT.
95	3V3_EXT			-	-	
97	3V3_EXT			-	-	
99	3V3_EXT			-	-	



The expansion connector on the OEM638 card is a *Samtec BSH-050-01-L-D-A-TR*. It mates with *Samtec ASP-166000-01* (this is a semi-custom part from Samtec that provides a mated height of 14 mm). The standard mating height for the OEM638 card is 14 mm.

Table 39: J4101 Expansion Header Pin-Out and Signal Description (even numbered pins)

Pin	Signal Name	Signal Type	Signal Direction	Polarity	Drive Strength (mA)	Description
2	IMUTXD / IMUTXD+	RS232 / RS422	Output	-	-	IMUTXD: RS232 Flow Control (± 25 V tolerant) IMUTXD+: RS422 Signaling (2 V differential typical) This is a standard RS232/RS422 communication port but is able to generate a time event and timestamp for reverse compatibility with the SPAN-MPPC card stack.
4	IMURTS / IMUTXD-	RS232 / RS422	Output	-	-	IMURTS: RS232 Flow Control (± 25 V tolerant) IMURXD-: RS422 Signaling (2 V differential typical)
6	IMURXD / IMURXD+	RS232 / RS422	Input	-	-	IMURXD: RS232 Flow Control (± 25 V tolerant) IMURXD+: RS422 Signaling (2 V differential typical)
8	IMUCTS / IMURXD-	RS232 / RS422	Input	-	-	IMUCTS: RS232 Flow Control (± 25 V tolerant) IMURXD-: RS422 Signaling (2 V differential typical)
10	GND			-	-	
12	SYNCOUT (EVENT_OUT7)	3.3V CMOS	Output	Rising / Falling Edge	8	Synchronization Output. Identical to EVENT_OUT signals but dedicated for the use of an attached IMU.
14	PV / EVENT_OUT3	3.3V CMOS	Output	Rising / Falling Edge	8	Event Output. Outputs a user-specified timing signal. Can be synchronized with PPS. Multiplexed with Position Valid (PV)
16	EVENT_OUT4	3.3V CMOS	Output	Rising / Falling Edge	8	Event Output. Outputs a user-specified timing signal. Can be synchronized with PPS.
18	EVENT_OUT5	3.3V CMOS	Output	Rising / Falling Edge	8	Event Output. Outputs a user-specified timing signal. Can be synchronized with PPS.
20	EVENT_OUT6	3.3V CMOS	Output	Rising / Falling Edge	8	Event Output. Outputs a user-specified timing signal. Can be synchronized with PPS
22	GND			-	-	
24	Reserved					

Pin	Signal Name	Signal Type	Signal Direction	Polarity	Drive Strength (mA)	Description
26	nRESETOUT / EVENT_IN2 / USERIO2	3.3V CMOS	Output/ Input	Rising / Falling Edge	-	nRESETOUT is multiplexed with EVENT_IN2/USERIO2. nRESETOUT outputs an active low pulse at system reset. When this pin is multiplexed to EVENT_IN2/USERIO2, the behavior is the opposite setting as USERIO2 / EVENT_IN2 (Pin 31) on the Main Header (P4001). Weak pull up internal to OEM638 when configured at Event Input
28	EVENT_IN3	3.3V CMOS	Input	Rising / Falling Edge	-	Event Input (Mark Input). A transition on this pin is logged and time stamped. Weak pull up internal to OEM638.
30	GND			-		
32	USERIO3	3.3V CMOS	IO	-	2	General Purpose IO (no internal pull if resistor used as input)
34	USERIO4	3.3V CMOS	IO	-	2	General Purpose IO (no internal pull if resistor used as input)
36	USERIO5	3.3V CMOS	IO	-	2	General Purpose IO (no internal pull if resistor used as input)
38	USERIO6	3.3V CMOS	IO	-	2	General Purpose IO (no internal pull if resistor used as input)
40	USERIO7	3.3V CMOS	IO	-	2	General Purpose IO (no internal pull if resistor used as input)
42	USERIO8	3.3V CMOS	IO	-	2	General Purpose IO (no internal pull if resistor used as input)
44	USERIO9	3.3V CMOS	IO	-	2	General Purpose IO (no internal pull if resistor used as input)
46	USERIO10	3.3V CMOS	IO	-	2	General Purpose IO (no internal pull if resistor used as input)
48	USERIO11	3.3V CMOS	IO	-	2	General Purpose IO (no internal pull if resistor used as input)
50	USERIO12	3.3V CMOS	IO	-	2	General Purpose IO (no internal pull if resistor used as input)
52	USERIO13	3.3V CMOS	IO	-	2	General Purpose IO (no internal pull if resistor used as input)
54	USERIO14	3.3V CMOS	IO	-	2	General Purpose IO (no internal pull if resistor used as input)

Pin	Signal Name	Signal Type	Signal Direction	Polarity	Drive Strength (mA)	Description
56	USERIO15	3.3V CMOS	IO	-	2	General Purpose IO (no internal pull if resistor used as input)
58	USERIO16	3.3V CMOS	IO	-	2	General Purpose IO (no internal pull if resistor used as input)
60	USERIO17	3.3V CMOS	IO	-	2	General Purpose IO (no internal pull if resistor used as input)
62	USERIO18	3.3V CMOS	IO	-	2	General Purpose IO (no internal pull if resistor used as input)
64	USERIO19	3.3V CMOS	IO	-	2	General Purpose IO (no internal pull if resistor used as input)
66	USERIO20	3.3V CMOS	IO	-	2	General Purpose IO (no internal pull if resistor used as input)
68	USERIO21	3.3V CMOS	IO	-	2	General Purpose IO (no internal pull if resistor used as input)
70	nRESET_IN	3.3V CMOS	Input	Active Low	-	Internally pulled high. To reset, hold below 0.4 V for a minimum of 1us. Parallel connection to P4001.33.
72	GND			-	-	
74	I2C3_SCL	Open Drain	IO	-	-	I ² C Interface #3, internally pulled up to 3.3 V. (Note: I ² C Address "1001 000" is used internally.)
76	I2C3_SDA	Open Drain	IO	-	-	
78	GND			-	-	
80	HSUSB1_VBUS	USB	Input	-	-	Used by the card to monitor activity on the USB1 interface. This pin cannot supply current to hosted devices but must be connected for normal operation.
82	HSUSB1_VBUS_EN	3.3V CMOS	Output	Active High	3	Control for an external 5 V power switch for USB1.
84	HSUSB1_D+	USB	IO	-	-	The differential data pair for USB1.
86	HSUSB1_D-	USB	IO	-	-	
88	Reserved					
90	GND			-	-	
92	GND			-	-	

Pin	Signal Name	Signal Type	Signal Direction	Polarity	Drive Strength (mA)	Description
94	4V5_36V_INPUT	Wide Range Supply Input		-	-	These pins may connect to an external wide range supply input. This is the preferred supply input for the wide-range supply (see also P4001).  If 4V5_36V_INPUT is used, do not connect to 3V3_EXT.
96	4V5_36V_INPUT			-	-	
98	4V5_36V_INPUT			-	-	
100	4V5_36V_INPUT			-	-	



The expansion connector on the OEM638 card is *Samtec's BSH-050-01-L-D-A-TR*. It mates with *Samtec ASP-166000-01* (this is a semi-custom part from Samtec that provides a mated height of 14 mm). The standard mating height for the OEM638 card is 14 mm.

Table 40: 3.3V CMOS Electrical Characteristics (-40 to 85°C)

Drive Strength (mA)	V_{IL}		V_{IH}		V_{OL}	V_{OH}	$R_{PULL-UP}$	$R_{PULL-DOWN}$
	min (V)	max (V)	min (V)	max (V)	max (V)	min (V)	typ (Ω)	typ (Ω)
2	-0.3	0.8	2	3.6	0.4	2.4	300	100
4	-0.3	0.8	2	3.6	0.4	2.4	300	100
8	-0.3	0.8	2	3.6	0.4	2.4	150	50

E.1.2 Power Supply

The OEM638 receiver can operate from either:

- 3.3 V +5%/-3% at up to 2.0 A
- or
- 4.5 V to 36 VDC input supply at up to 1.5 A

Power consumption will vary greatly, depending on which features are active.

The OEM638 has integrated reverse voltage protection (to -10 VDC) on its 3.3 V supply input port. The Wide-Range supply port is reverse protected to -40 VDC.

If operating from the 3.3 V supply input, bulk supply bypassing (approximately 50 μ F) and high frequency bypassing (0.1 μ F and 220 pF) near the 3.3 V supply pin is recommended for optimal performance. If operating from the Wide-Range supply, high-frequency bypassing (0.1 μ F and 220 pF) is recommended.

E.1.3 Antenna Power Output

The OEM638 card supplies a software-selectable 3.3 V or 5 V to the center pin of the MMCX RF connector to power an external antenna (the return is the outer conductor of the coax). There is also the option to provide an external voltage to the LNA (up to 18 VDC).

This port is capable of providing up to 200 mA to a connected antenna. The typical current draw for a NovAtel antenna is 25-40 mA.

The internally-generated 3.3 V and 5 V supplies are over current protected. If the external LNA supply is used, the supply **must** self-limit to 125 mA max to avoid damage to the OEM638 receiver. (There is no over current protection on the external LNA supply input.)

E.1.4 Logic-Level I/O

The OEM638 provides a number of 3.3 V Logic-level I/O pins for status indication, communication and timing:

- **PPS**: Pulse-Per-Second
- **VARF**: Variable Frequency (a software-configurable clock output)
- **ERROR**: Error indication
- **PV**: Position Valid (Used to indicate when the receiver has calculated a valid position)
- **STATUS_RED / STATUS_GRN**: Receiver status indicators (used to control external LEDs)
- **COM3 / COM4 / COM5**: UARTs (including RTS/CTS flow control)
- **EVENT_IN(1,2,3,4)**: Event Inputs
- **EVENT_OUT(1-6) + SYNCOUT (EVENT_OUT7)**: Event Outputs
- **USERx(0-21) 2xI2C, 2xSPI**: User GPIO and additional interfaces (available through NovAtel's UserApp API)

These I/O require additional ESD protection if they are to be routed to connectors.

Some users may require additional drive strength on the PPS signal. The *Figure 91, Example - ESD Protection for Strokes (optional buffering for PPS)* on page 182 shows a suitable buffer that may be used. R222 may be used to limit the drive strength of the PPS output buffer (if desired). This buffer has a propagation delay of approximately 5-6 nanoseconds.

A similar ESD protection circuit to the one shown below should be used on any OEM638 Logic-level signal that will be routed to an enclosure connector. (If an EVENT_IN or EVENT_OUT line is routed to an enclosure connector the capacitance must be minimized—these signals may require buffering in some applications.)

Figure 91: Example - ESD Protection for Strokes (optional buffering for PPS)

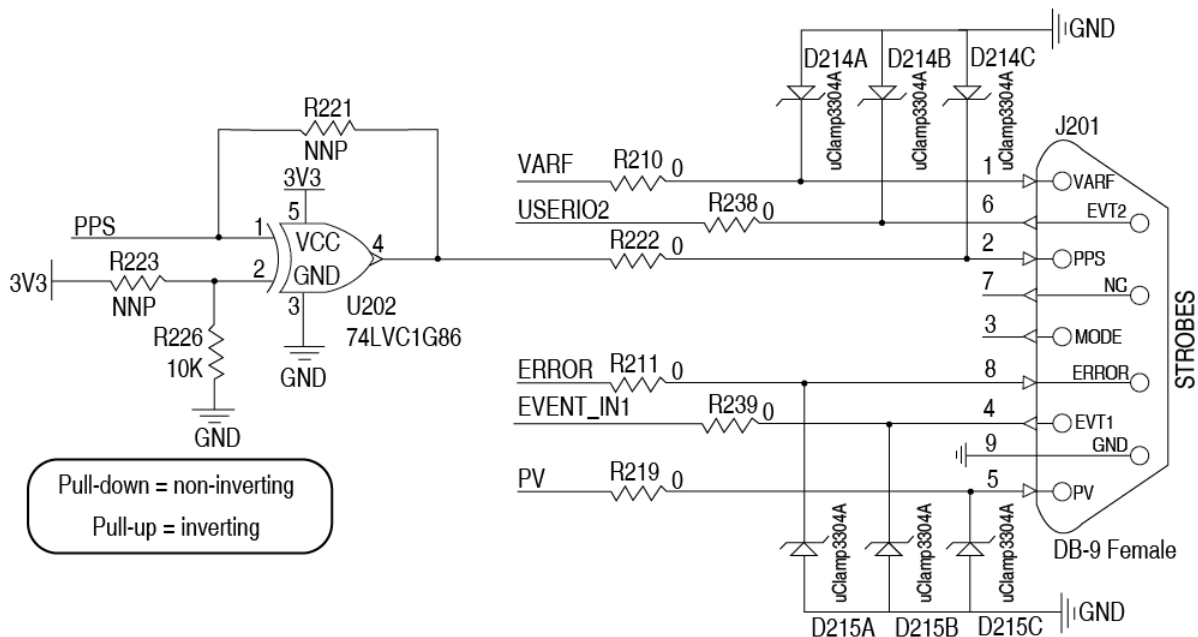

The STATUS_RED, STATUS_GRN, ERROR and PV signals are generally used on enclosure products to show the current status of the receiver. These signals may require a buffer to drive an LED. An example of a suitable buffer circuit is shown below:

Figure 92: Example - LED Drive Buffer for PV and ERROR Signals

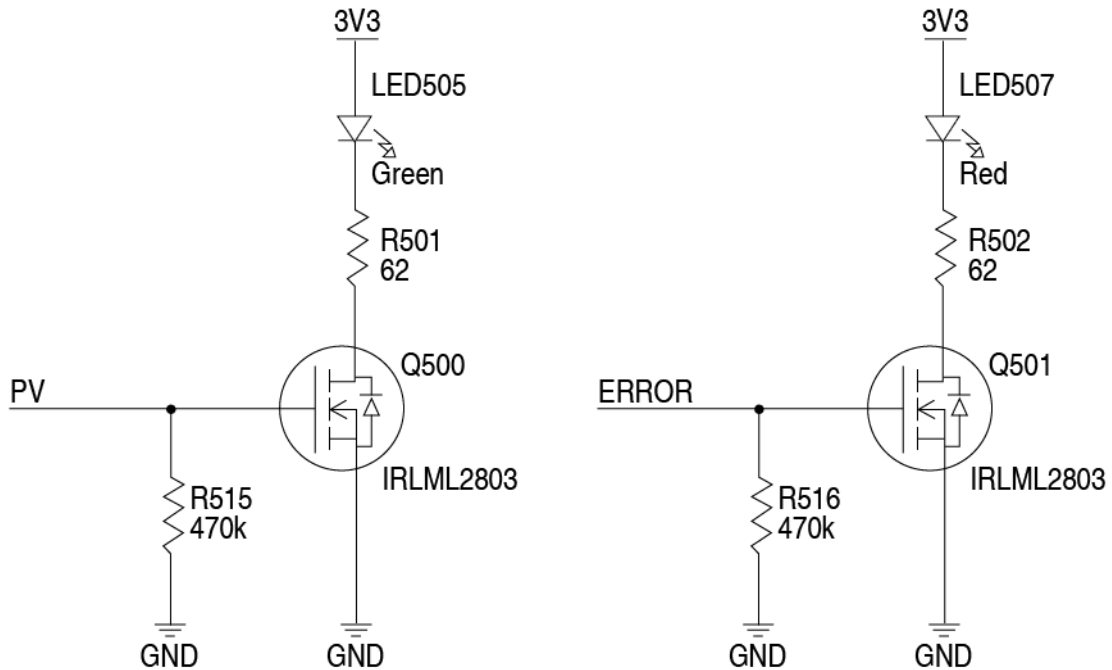

Table 41: Bill of Materials (critical components)

Designator	Manufacturer	Manufacturer Part Number
U202	Texas Instruments	SN74LVC1G86DCK
D214, D215	Semtech	uClamp3304A.TCT

E.1.5 Communication Ports

COM1, COM2 and IMUCOM (COM6) present software-selectable RS232 or RS422 signal levels. RTS/CTS flow control is available on each port. COM1 and IMUCOM are protected to ±15 kV (HBM) discharges. COM2 is protected to ±26 kV (HBM) discharges. Additional ESD protection is recommended near the enclosure connectors for any signal leaving an enclosure.

COM3, COM4 and COM5 are 3.3 V CMOS-level signals only. RTS/CTS flow control is available for each interface but COM2 also has DTR/DCD flow control (for reverse-compatibility with the OEMV-3G receiver). These signals are 3.3 V CMOS UARTs that require an external transceiver to connect to an RS232 or RS422 device. These pins have some ESD protection but (again) additional ESD protection near the connectors for any signals leaving an enclosure is recommended.

A combination of a series ferrite bead and small value shunt capacitor is recommended on any RS232/RS422 lines that leave the enclosure (similar to the arrangement used on the I/O ports and CAN interfaces below). (The TVS recommended for 3.3 V CMOS-level I/O is unsuitable for RS232-level I/O. An additional low capacitance TVS device with a clamping voltage between 18 V and 25 V should be selected for RS232 lines requiring additional protection.)

E.1.6 CAN Interfaces

The OEM638 provides two CAN ports through the expansion header. The transceivers are provided on the OEM638. The following figure shows a typical CAN protection and EMI filtering arrangement.

The combination of ferrite beads and small value capacitors are not necessarily required but may provide improved EMI performance. A low capacitance TVS device is shown on the schematic to provide ESD protection.

Figure 93: Example - CAN Protection and Filtering Circuit

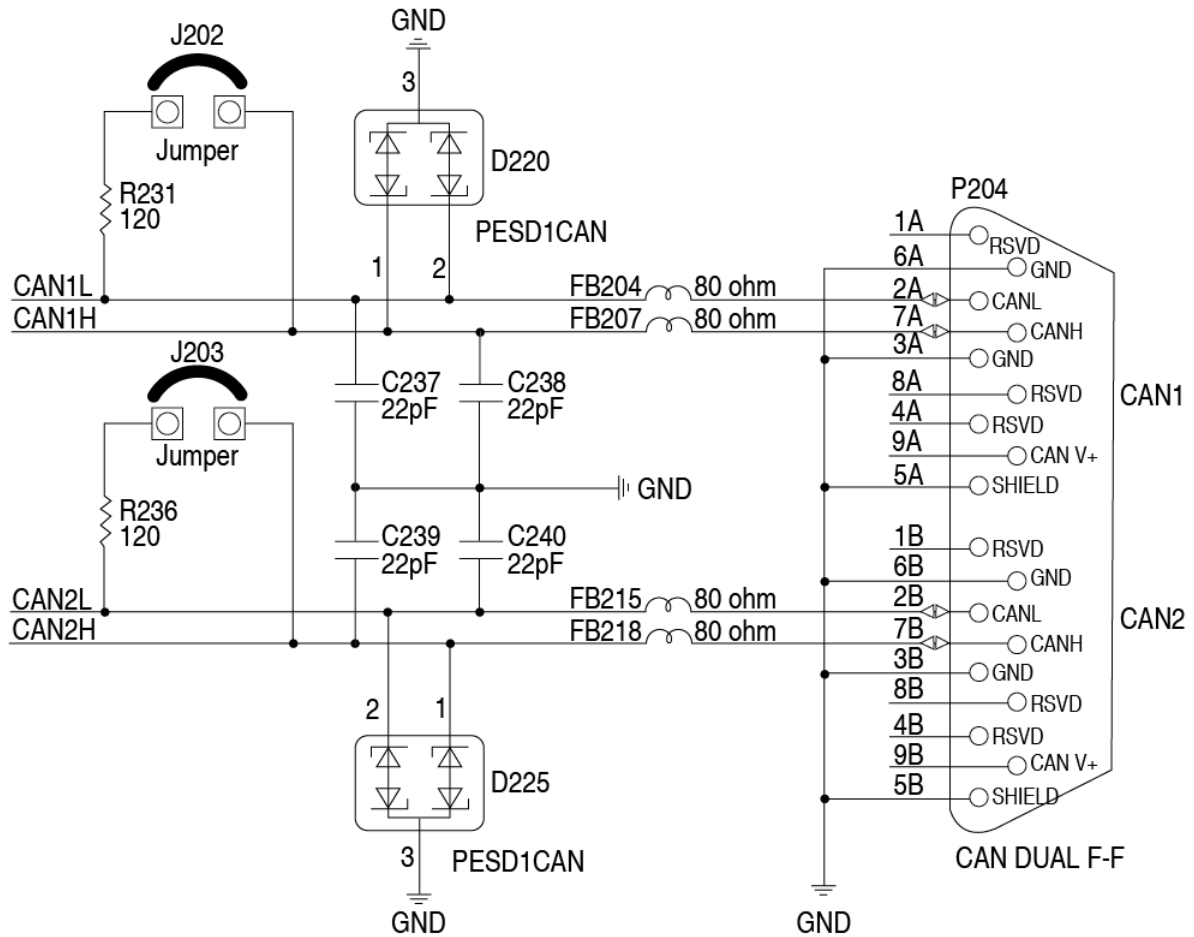

The 120 Ω termination resistor (R231 and R236) should only be used when the CAN device is used at one end of the CAN bus. Multiple terminations along the length of the CAN bus will degrade performance for all CAN devices on that bus.

Table 42: Bill of Materials (critical components)

Designator	Manufacturer	Manufacturer Part Number
FB204, FB207, FB215, FB218	TDK	MMZ1608S800A
D220, D225	NXP Semiconductor	PESD1CAN,215

E.1.7 USB Interfaces

The OEM638 provides three USB2.0 High Speed interfaces.

HSUSB0 is configured as a device and is capable of operating at High Speed (480Mbps). Full speed (12 Mbps) and Low Speed (1.5 Mbps).

HSUSB1 and HSUSB2 are host ports and are capable of High Speed (480 Mbps) operation only. If it is desired to use the host ports with Full or Low Speed devices, a USB hub (with a transaction translator) is required between the OEM638 and the USB device. These ports are designed with a 3.3 V CMOS-level control output for an external 5 V power switch that will provide the power switching and current limit protection.

It is imperative for signal integrity and EMI reasons that the differential data traces for each USB interface be routed as a 90 Ω differential pair. Use of a small value common mode choke (as shown in *Figure 94, Example - Connecting HSUSB0 to a Micro-B Type USB Connector* on page 185) may improve the radiated emissions performance. Small ferrite beads, ESD protection are shown on VBUS and UID lines as a contingency against radiated emissions.

The “HSUSBx_VBUS” signals are only present so that the PHY on the OEM638 may monitor activity on each bus and are required for operation, although they will only carry a few mA maximum. The traces for VBUS and UID should be routed away from any high current switching nets and high frequency signals. The common mode choke, ferrite beads and bypass capacitor should be placed as close as possible to the USB connector.

If a Type B or Type mini-B USB connector is used for HSUSB0, the “HSUSB0_UID” pin from the OEM638 should be left floating (as there is no pin on those variants of the USB connector to connect to). If a Type micro-B connector is used, the “HSUSB0_UID” pin should be tied to the UID pin of the connector (as shown below).

Figure 94: Example - Connecting HSUSB0 to a Micro-B Type USB Connector

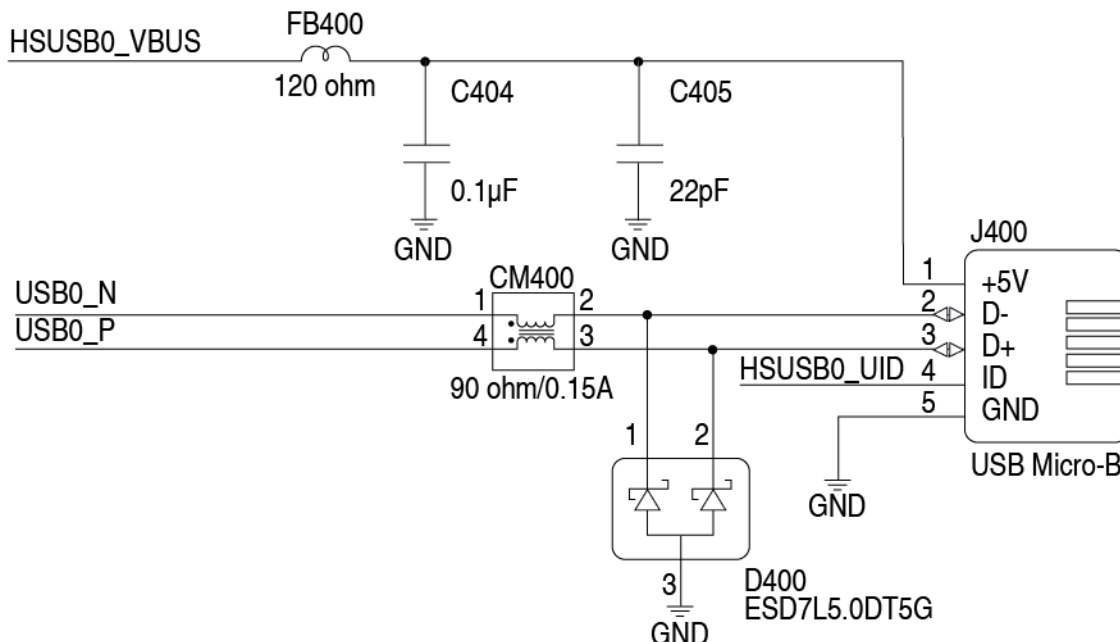
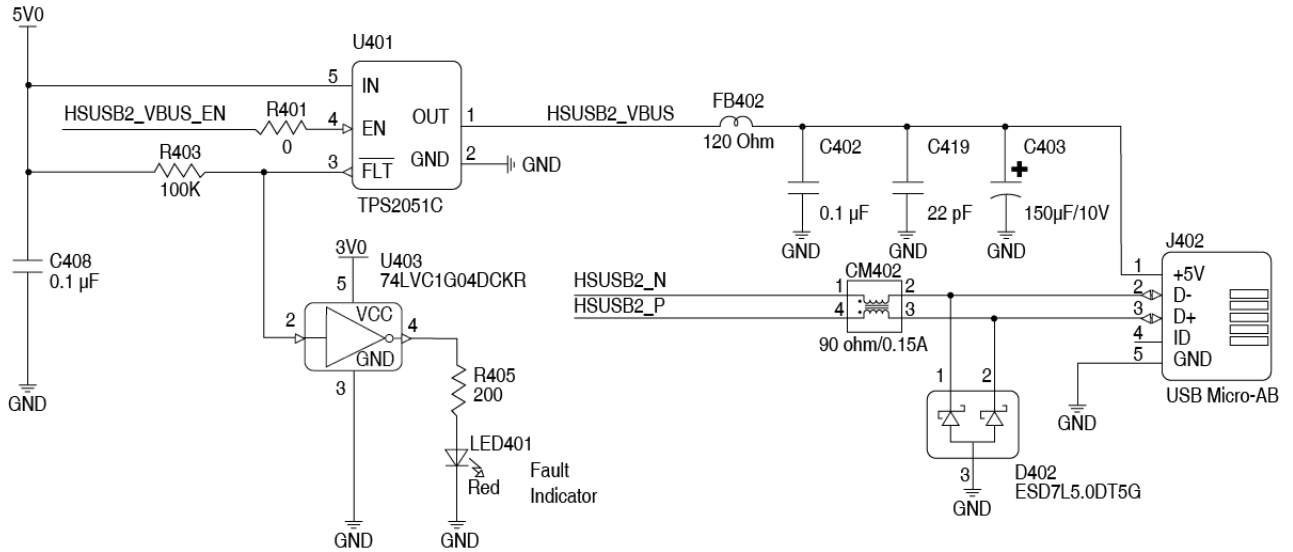

Figure 95: Example – Connecting HSUSB1 or HSUSB2 to a Micro-AB Type USB Connector



Although all pins on the OEM638 card have ESD protection, a low capacitance TVS device is also recommended near any enclosure connector for all USB signals (before the signals leave the enclosure or the PCB).

Table 43: Bill of Materials

Designator	Manufacturer	Manufacturer Part Number
U401	Texas Instruments	TPS2051C
D400, D402	On Semi	ESD7L5.0DT5G
CM400, CM402	MuRata	DLP11SN900HL2L

E.1.8 Ethernet Port

The OEM638 provides a 10/100 Ethernet port with auto-negotiation. The Ethernet interface is not enabled by default and may require configuration (refer to details that follow and consult the [OEM6 Family Firmware Reference Manual](#) (OM-20000129) for instructions on configuring the Ethernet interface and the `SAVEETHERNETDATA` command.

PHY terminations are provided on the OEM638 card and a 3.3 V output is presented to bias the Ethernet magnetics. This 3.3 V bias output from the OEM638 card is not to be used for any purpose other than biasing the Ethernet magnetics.

A reference schematic is shown below.

Figure 96: Example - Ethernet Reference Schematic

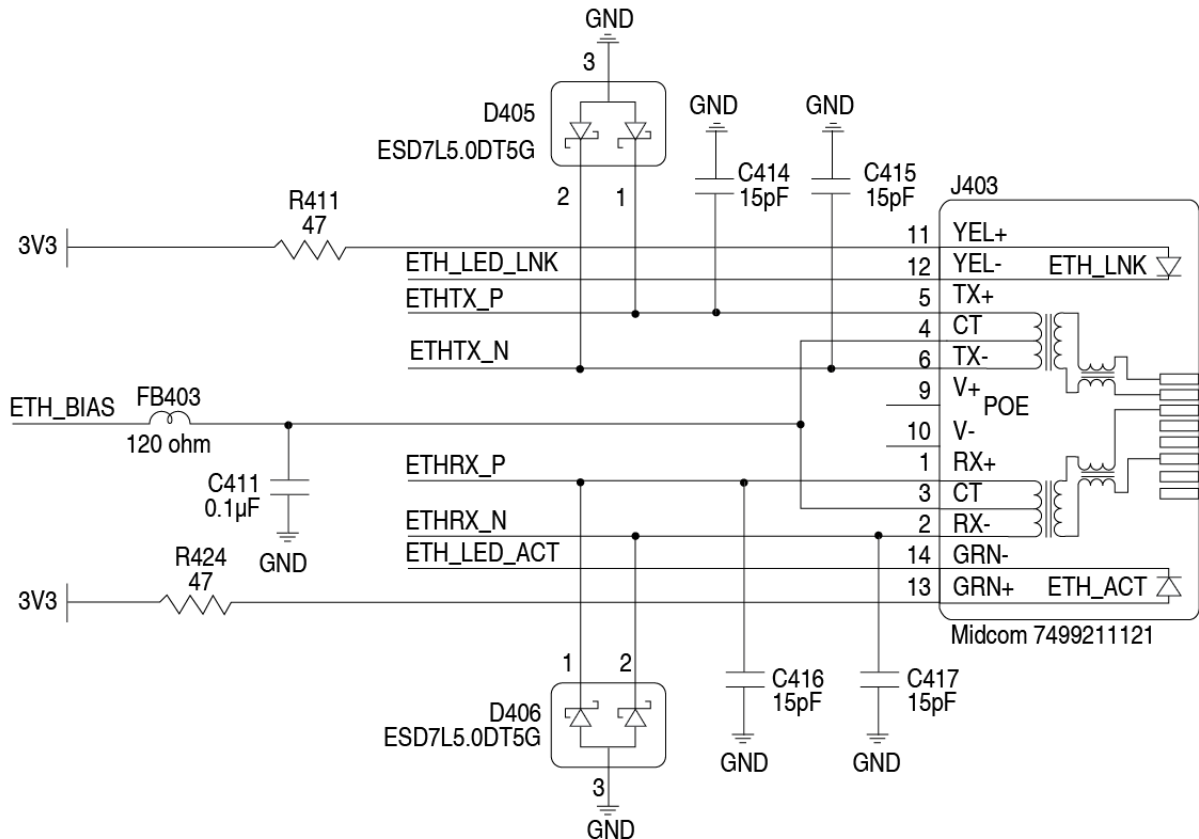

Care must be taken to provide $100\ \Omega \pm 10\%$ differential pairs over unbroken reference (ground) planes up to the pins on the Ethernet connector.

The Ethernet magnetics (inside the Ethernet jack on the part shown) provide high voltage isolation and protection components for differential mode transients. ESD protection components must be placed near the connector pins.

The spacing between receive and transmit pairs should be at least 3-4 times the width of each differential pair (both traces plus the separation distance) to minimize crosstalk. More than two layer changes should be avoided (single layer routing is best) and care must be taken to ensure reference planes do not change when changing layers. If in doubt, contact your PCB vendor for appropriate dimensions for the differential pairs.

Alternately, discrete Ethernet magnetics may be used. Ensure that the Ethernet magnetics selected meet the specifications in the table below. Ensure the magnetics are no more than 15 cm (6 inches) from the OEM638 expansion connector (the shorter the better). A guide to using discrete magnetics is contained in the OEM628 Technical Reference Section of this manual.

The OEM638 Ethernet LED control lines may sink current directly from an LED (with an appropriate current-limiting resistor). The 3.3 V supply used to bias the Ethernet magnetics must not be used to drive the LEDs. The LED drive pins are 3.3 V tolerant only.

The following table gives recommended Ethernet transformer characteristics:

Table 44: Recommended Ethernet Transformer Characteristics

Parameter	Value	Test Condition
Turns Ratio	1 CT : 1 CT \pm 3%	
Open-cct Inductance (min)	350 μ H	100 mV, 100 kHz, 8 mA
Insertion Loss (max)	1.0 dB (max)	1 - 100 MHz
Return Loss (min)	-18 dB (min)	1 - 10 MHz
	-16 dB (min)	10 - 30 MHz
	-12 dB (min)	30 - 60 MHz
	-10 dB (min)	60 - 80 MHz
Common-Mode Rejection	-30 dB (min)	1 - 100 MHz
Crosstalk	-30 dB (min)	1 – 100 MHz
HIPOT (min)	1500 Vrms	For 1 minute

Table 45: Bill of Materials (Critical Components Only)

Designator	Manufacturer	Manufacturer Part Number
J403	Wurth Elektronik	7499211121A
	Midcom	7499211121
D405, D406	On Semi	ESD7L5.0DT5G
FB403	MuRata	BLM18PG121SN1D

E.1.9 System Performance

The OEM638 receiver (as with any precision GNSS product) is an extremely sensitive radio receiver.

Typical GNSS signal levels are on the order of -145 dBm. Spurious emissions from digital logic (especially a microprocessor) or a nearby radio transmitter can easily meet the appropriate EU or FCC emission limits and still have emissions several orders of magnitude above the level of the GNSS carrier.

These emissions may desensitize the GNSS receiver and lead to performance degradation (low carrier to noise ratios, position accuracy or loss of lock in extreme cases).

There are two bands of interest:

- **Low Band (1165 MHz to 1300 MHz):** contains Galileo E5A, GPS L5, Galileo E5B, BeiDou B2, GPS L2 and GLONASS L2.
- **High Band (1525 MHz to 1613 MHz):** contains TerraStar, BeiDou B1, Galileo E1, GPS L1 and GLONASS L1

NovAtel and the OEM638 development team have put significant effort into mitigating RF interference on the GNSS card itself. However, if an emission (fundamental or harmonic) from equipment co-located with the GNSS receiver or antenna falls into one of these bands, there are a few things that integrators can do to ensure good system performance:

- Place radio transmitters and their associated antennas at least one meter from the GNSS antenna and OEM638 card (for example, a cellular radio antenna).
- Provision for RF shielding over all high-speed digital logic circuitry (even if the design meets the required emissions regulations). A CPU operating at 400 MHz will produce an emission at 1200 MHz (3rd harmonic) and another at 1600 MHz (4th harmonic)—the emissions may be strong enough to affect the GNSS system's performance as both signals are very close to (or inside of) the GNSS reserved spectrum. Similar provisions should be made for any RF circuitry near the GNSS receiver or antenna.
- Run the OEM638 coaxial RF cable away from high speed digital logic, other radio sections and high current nets (as in switching power supplies).

F.1 FlexPak6 (FPk6)

INPUT/OUTPUT CONNECTORS	
ANT	TNC female jack, 50 Ω nominal impedance +5 VDC ($\pm 5\%$) 100 mA max (output from FlexPak6 to antenna/LNA)
PWR	4-pin LEMO
COM1	9-pin DB9 (maximum baud rate 921600)
COM2	9-pin DB9 ^a (maximum baud rate 921600)
USB	mini-AB
Ethernet, CAN, I/O	DB-HD15
PHYSICAL	
Size	45 x 147 x 123 mm
Weight	337 g maximum
Mounting System	Integral flange with two 7 mm (9/32 inch) diameter mounting holes 133 mm (5.25 inches) apart
ENVIRONMENTAL	
Operating Temperature	-40°C to +75°C
Storage Temperature	-40°C to +85°C
Humidity	MIL-STD-810G, Method 507.5, Procedure II (95%)
Immersion	IEC 60529 IPX7
Random Vibration	MIL-STD-810G, Method 514.6, Category 24 (20 to 2000 Hz, 7.7 g RMS)
Sinusoidal Vibration	SAE J1211 (10 Hz to 1000 Hz, 4 g)
Bump	IEC 60068-2-27 (10 g)
Shock	MIL-STD-810G, Method 516.6, Procedure 1 (40 g)
Acceleration	MIL-STD-810G, Method 513.6, Procedure II (4 g, 8 g, 12 g, 16 g)
POWER REQUIREMENTS	
Input Voltage	+6 to +36 VDC
Power Consumption	Typical 1.8 W (power consumption values for GPS L1/L2 at 6 VDC with Ethernet disabled) Maximum 3.1 W
In-Rush Current Consumption	6.6 A for less than 60 μ s (typical)

a. COM2 can be dynamically changed to RS-422 by grounding I/O pin 9. Refer to *Table 47, FlexPak6 I/O Port Pin-Out Descriptions* on page 192 for details.

Figure 97: FlexPak6 Dimensions

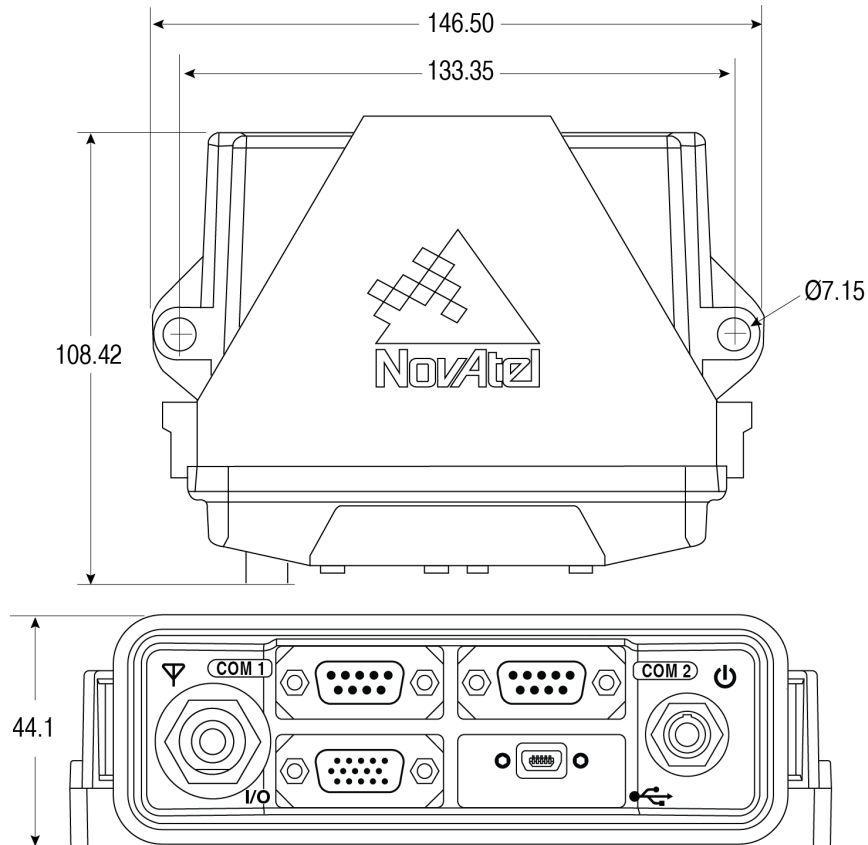

Note: Dimensions are in millimetres.

Table 46: FlexPak6 Port Pin-Out Descriptions

Connector Pin No.	COM1		COM2	
	RS-232	RS-422 ^a	RS-232	RS-422 ^b
1	N/C	N/C	N/C	N/C
2	Rx	Rx+	Rx	Rx+
3	Tx	Tx+	Tx	Tx+
4	N/C	N/C	POUT ^c	POUT ^c
5	GND	GND	GND	GND
6	N/C	N/C	N/C	N/C
7	RTS	Tx-	RTS	Tx-
8	CTS	Rx-	CTS	Rx-
9	N/C	N/C	N/C	N/C

- a. Mode selected via software commands. Refer to the SERIALPROTOCOL command in [OEM6 Family Firmware Reference Manual](#) (OM-20000129).
- b. COM2 can be dynamically changed to RS-422 by grounding I/O pin 9. Connect pin 5 (ground) to pin 9 to switch COM2 to RS-422 mode. Refer to [Table 47, FlexPak6 I/O Port Pin-Out Descriptions](#) on page 192 for details.
- c. Current is limited to 1 A.



The FlexPak6 provides an output voltage on pin 4 of COM2 (POUT) that matches the voltage used to power the FlexPak6.

The FlexPak6 can accept voltages up to 36 VDC, which is greater than the RS-232 specified maximum 25 VDC. As a result, you can damage equipment that is connected to COM2 by sending voltages higher than the RS-232 specification allows.

Table 47: FlexPak6 I/O Port Pin-Out Descriptions

Pin	Signal Name	Input/Output	Signal Descriptions
1	ETH_TD+	Input/Output	
2	ETH_RD+	Input/Output	
3	CAN1+	Input/Output	
4	No connect		
5	GND		Digital ground
6	ETH_TD-	Input/Output	
7	ETH_RD-	Input/Output	
8	CAN1-	Input/Output	
9	MODE	Input	When grounded (e.g., connected to pin 5), enables RS-422 mode for COM2. RS-232 is the unconnected default
10	EVENT2	Input	Mark 2 input. This input has in internal pull-down and buffers the input to the OEM628 card
11	EVENT1	Input	Mark 1 input. This input has in internal pull-down and buffers the input to the OEM628 card
12	VARF	Output	Variable frequency out
13	ERROR	Output	Indicates a fatal error when high. The antenna port LED also turns red during a fatal error
14	PV	Output	Valid position available. The antenna port LED also turns green for a valid position
15	PPS	Output	Pulse per second

Table 48: FlexPak6 Strobe Electrical Specifications

Strobe	Sym	Min (V)	Max (V)	Current (mA)	Conditions
Event1 (Mark 1)	V _{IL}		0.8		VCC = 3.3 V compatible; 85°C
Event2 (Mark2)	V _{IH}	2.0			
PPS	V _{OL}		0.55	24	VCC = 3.3 V; 85°C
PV VARF	V _{OH}	2.3			



Also see *Strobes* on page 75.



Refer to *Appendix H, Enclosure Cables Technical Specifications* on page 198 for details regarding the FlexPak6 cables.

G.1 FlexPak6D 

INPUT/OUTPUT CONNECTORS	
ANT1	SMA female jack, 50 Ω nominal impedance
ANT2	+5 VDC ($\pm 5\%$) 100 mA max (output from FlexPak6D to antenna/LNA)
PWR	4-pin LEMO
COM1	9-pin DB9 (maximum baud rate 921600)
COM2	9-pin DB9 ^a (maximum baud rate 921600)
USB	mini-AB
I/O	DB-HD15
PHYSICAL	
Size	147 x 115 x 45 mm
Weight	312 g maximum
Mounting System	Integral flange with two 7 mm (9/32 inch) diameter mounting holes 133 mm (5.25 inches) apart
ENVIRONMENTAL	
Operating Temperature	-40°C to +75°C
Storage Temperature	-51°C to +85°C
Humidity	MIL-STD-810G, Method 507.5, Procedure II (95%)
Immersion	IEC 60529 IPX7
Random Vibration	MIL-STD-810G, Method 514.6, Category 24 (20 to 2000 Hz, 7.7 g RMS)
Bump	IEC 60068-2-27 (25 g)
Shock	MIL-STD-810G, Method 516.6, Procedure 1 (40 g)
Acceleration	MIL-STD-810G, Method 513.6, Procedure II (4 g, 8 g, 12 g, 16 g)
POWER REQUIREMENTS	
Input Voltage	+6 to +36 VDC
Power Consumption	Typical 1.9 W (power consumption values for GPS L1/L2 at 6 VDC) Maximum 3.35 W
In-Rush Current Consumption	6.6 A for less than 60 μ s (typical)

a. COM2 can be dynamically changed to RS-422 by grounding I/O pin 9. Refer to *Table 49, FlexPak6D Port Pin-Out Descriptions* on page 195 for details.

Figure 98: FlexPak6D Dimensions

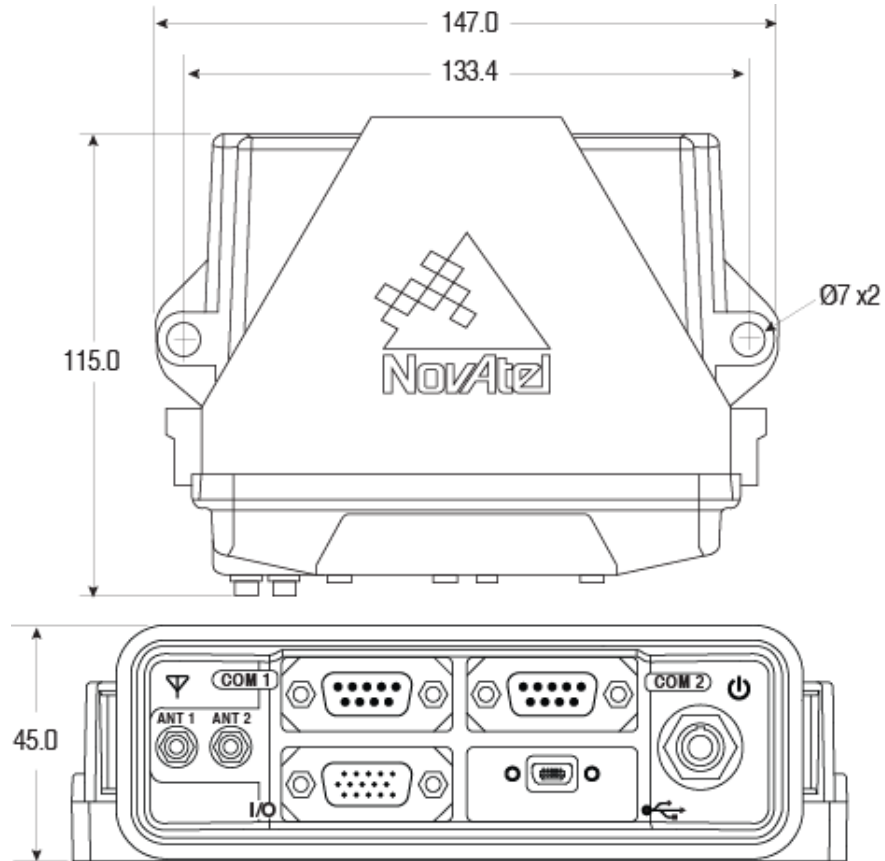

Note: Dimensions are in millimetres.

Table 49: FlexPak6D Port Pin-Out Descriptions

Connector Pin No.	COM1		COM2	
	RS-232	RS-422 ^a	RS-232	RS-422
1	N/C	N/C	N/C	N/C
2	Rx	Rx+	Rx	Rx+
3	Tx	Tx+	Tx	Tx+
4	N/C	N/C	POUT ^b	POUT ^b
5	GND	GND	GND	GND
6	N/C	N/C	N/C	N/C
7	RTS	Tx-	RTS	Tx-
8	CTS	Rx-	CTS	Rx-
9	N/C	N/C	N/C	N/C

a. Mode selected via software commands. Refer to the SERIALPROTOCOL command in [OEM6 Family Firmware Reference Manual](#) (OM-20000129).

b. Current is limited to 1 A.



The FlexPak6D provides an output voltage on pin 4 of COM2 (POUT) that matches the voltage used to power the FlexPak6D.

The FlexPak6D can accept voltages up to 36 VDC, which is greater than the RS-232 specified maximum 25 VDC. As a result, you can damage equipment that is connected to COM2 by sending voltages higher than the RS-232 specification allows.

Table 50: FlexPak6D I/O Port Pin-Out Descriptions

Pin	Signal Name	Input/Output	Signal Descriptions
1	Reserved		
2			
3			
4			
5	GND		Digital ground
6	Reserved		
7			
8			
9	MODE	Input	When grounded (e.g., connected to pin 5), enables RS-422 mode for COM2. RS-232 is the unconnected default
10	EVENT2	Input	Mark 2 input. This input has in internal pull-down and buffers the input to the OEM617Dcard
11	EVENT1	Input	Mark 1 input. This input has in internal pull-down and buffers the input to the OEM617D card
12	VARF	Output	Variable frequency out
13	Reserved		
14	PV	Output	Valid position available. The antenna port LED also turns green for a valid position
15	PPS	Output	Pulse per second

Table 51: FlexPak6D Strobe Electrical Specifications

Strobe	Sym	Min (V)	Max (V)	Current (mA)	Conditions
Event1 (Mark 1) Event2 (Mark2)	V _{IL}		0.8		VCC = 3.3 V compatible; 85°C
	V _{IH}	2.0			
PPS	V _{OL}		0.55	24	VCC = 3.3 V; 85°C
	V _{OH}	2.3			
PV	V _{OL}		0.55	10	VCC = 3.3 V; 85°C
	V _{OH}	2.2			
VARF	V _{OL}		0.55	24	VCC = 3.3 V; 85°C
	V _{OH}	2.4			



Also see *Strobes* on page 75.



Refer to *Appendix H, Enclosure Cables Technical Specifications* on page 198 for details regarding the FlexPak6D cables.

H.1 FlexPak6 and FlexPak6D Cables

FPk6D

CAN and Ethernet are not available on this receiver.

H.1.1 I/O Breakout Cable (NovAtel part number 01018649)

The Ethernet and CAN on the FlexPak6 can be accessed by inserting the I/O breakout cable's female DB-HD15 connector into the I/O port. This provides a standard receptacle for Ethernet connectivity and a DB9 connector for CAN. Access to the I/O line signals (see *Table 52, I/O Breakout Cable Wiring*, on page 198) are available on the DB-HD15 male connector and the DB9 access I/O strobe port cable (see *Section H.1.2, I/O DB-HD15 Strobe Port Cable (NovAtel part number 01018651)* on page 199). The breakout cable is approximately 40 cm in length (see *Figure 99, I/O Breakout Cable* on page 198) and is RoHS compliant.

Figure 99: I/O Breakout Cable

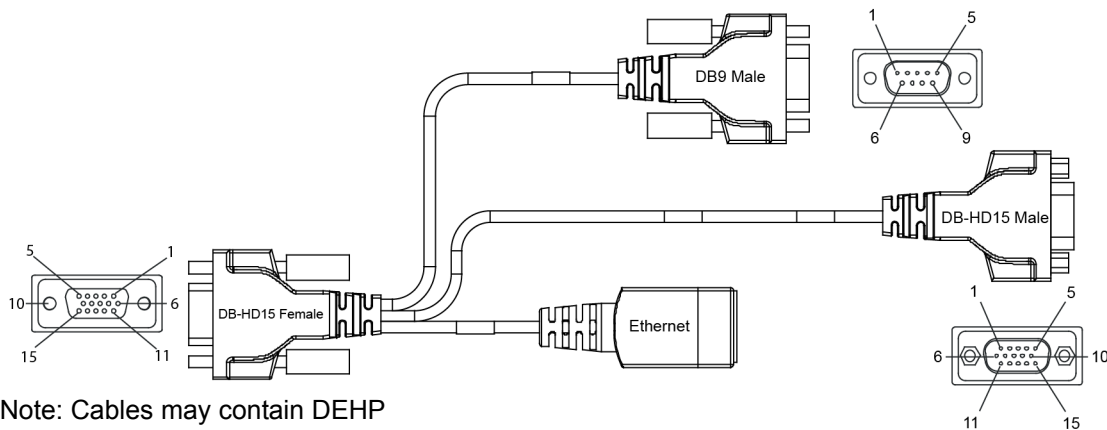

Note: Cables may contain DEHP

Table 52: I/O Breakout Cable Wiring.

Signal	DB-HD15 Female	DB9 Male	DB-HD15 Male	Ethernet ^a
Signal ground	5	3, 5	5	-
^a CAN1-	8	2	-	-
^a CAN1+	3	7	-	-
^a ETH_TD+	1	-	-	1
^a ETH_RD+	2	-	-	3
^a ETH_TD-	6	-	-	2
^a ETH_RD-	7	-	-	6
No connect	4	-	-	-
MODE	9	-	9	-
EVENT2	10	-	10	-
EVENT1	11	-	11	-
VARF	12	-	12	-
^a ERROR	13	-	13	-
PV	14	-	14	-
PPS	15	-	15	-

a. Neither Ethernet nor CAN are available on the FlexPak6D.

H.1.2 I/O DB-HD15 Strobe Port Cable (NovAtel part number 01018651)

The strobe lines on the FlexPak6 and FlexPak6D can be accessed by inserting the female DB-HD15 connector of the I/O strobe port cable into the I/O port. The other end of this cable is provided without a connector to provide flexibility. The jacket insulation is cut away slightly from the end but the insulation on each wire is intact. The cable is approximately 2 m in length. See *Figure 100, I/O DB-HD15 Strobe Port Cable* on page 199. This cable is RoHS compliant.

Figure 100: I/O DB-HD15 Strobe Port Cable

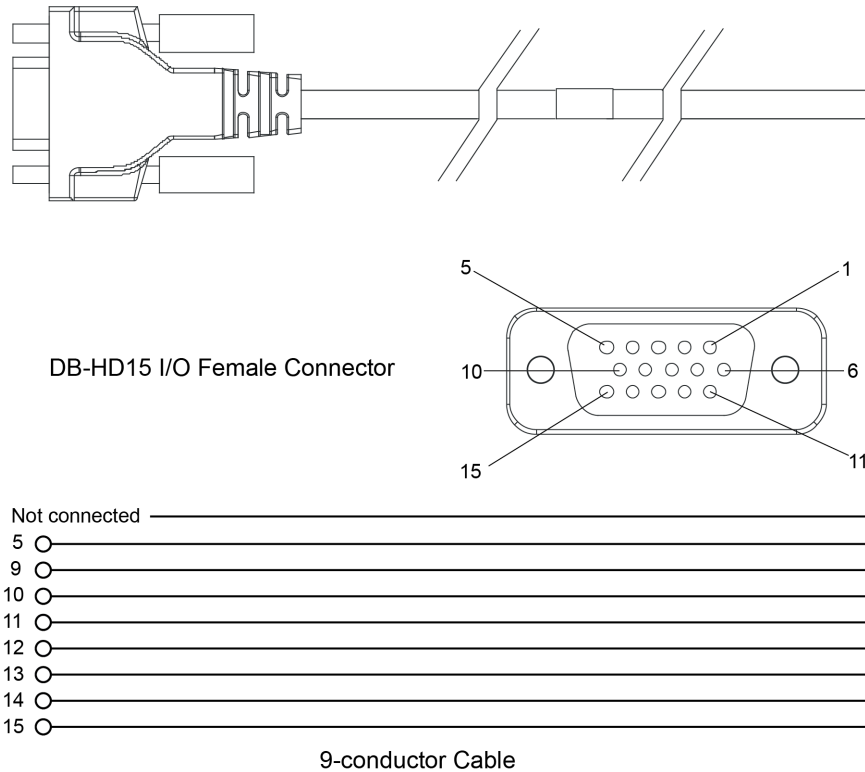



Table 53: I/O Strobe Port Cable Wiring

I/O Port Pin	I/O Port Signal	I/O Port Cable Wire Color
Not connected		Blue
5	Ground	White/Grey
9	MODE	Red
10	EVENT2	Green
11	EVENT1	Orange
12	VARF	Black
^a 13	ERROR	Violet
14	PV	Yellow
15	PPS	Brown

a. Not available on the FlexPak6D.

 All unlisted pins on the cable are not connected.

H.1.3 Straight Through Serial Cable (NovAtel part number 01018520)

This cable can be used to connect the FlexPak6 and FlexPak6D to a modem or radio transmitter to propagate differential corrections. The cable is equipped with a female DB9 connector at the receiver end. The male DB9 connector at the other end is provided to plug into your user-supplied equipment (please refer to your modem or radio transmitter user guide for more information on its connectors). The cable is approximately 2 m in length. See *Figure 101, Straight Through Serial Cable* on page 200. This cable is RoHS compliant.

Figure 101: Straight Through Serial Cable

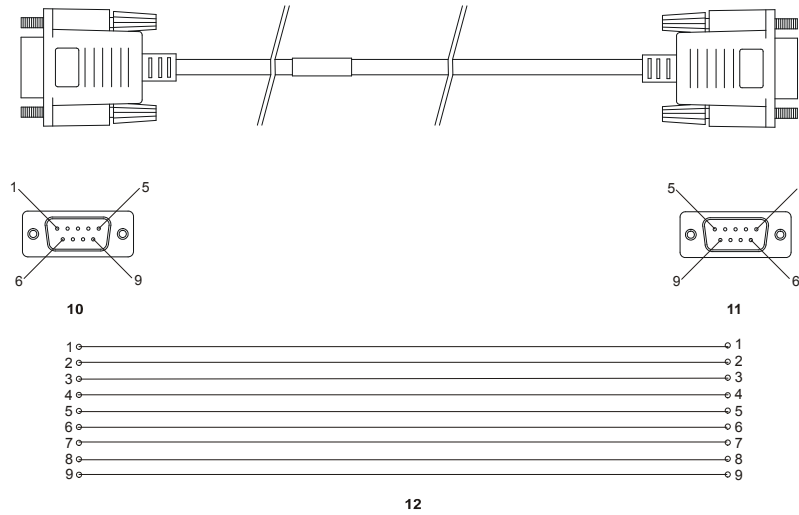

Reference	Description
10	DB9P (male) connector
11	DB9S (female) connector
12	9-conductor cable

H.1.4 Null Modem Cable (NovAtel part number 01017658)

This cable supplied with the FlexPak6 and FlexPak6D, see *Figure 102, Null Modem Cable* on page 201, provides an easy means of communications with a PC. The cable is equipped with a 9-pin connector at the receiver end which can be plugged into the COM or COM2 port. At the PC end, a 9-pin connector is provided to accommodate a PC serial (RS-232) communication port. This cable is RoHS compliant.

Figure 102: Null Modem Cable

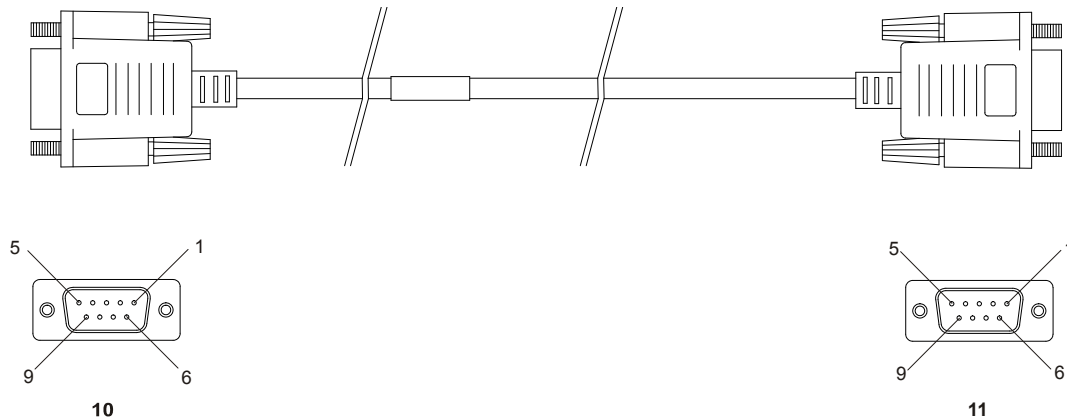

Table 54: Null Modem Cable Wiring

Connector	Pin Number						
To DB9S (10)	2	3	8	7	4	5	1 & 6
To DB9S (11)	3	2	7	8	1 & 6	5	4

Note: Cables may contain DEHP.

H.1.5 12 V Power Accessory Cable (NovAtel part number 01017663)

The power accessory cable supplied with the FlexPak6 and FlexPak6D, see *Figure 103, 12 V Power Accessory Cable* on page 202, provides a convenient means for supplying +12 VDC. While the receiver is capable of operating over a wider input voltage range, the accessory plug should not be used above +12 V. The accessory plug includes a fuse. If the accessory plug is not used, the alternative wiring must also include a fuse.

Input is provided through the standard 12 V power outlet. The output from the power adapter utilizes a 4-pin LEMO connector (LEMO part number FGG.0B.304.CLAD52Z) and plugs directly into the power input located on the front of the FlexPak6. This cable is RoHS compliant.

For alternate power sources, see *FlexPak6 and FlexPak6D Alternative Power Source* on page 47.

Figure 103: 12 V Power Accessory Cable

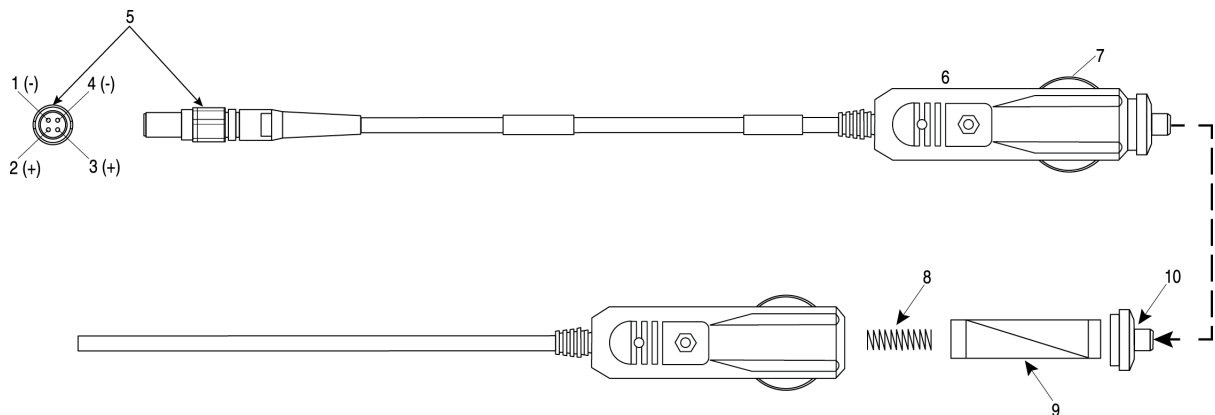

Reference	Description	Reference	Description
1	- (black)	6	Accessory Plug
2	+ (red)	7	Ground (side tab)
3	+ (orange or green)	8	Spring
4	- (brown or white)	9	6 A slow-blow fuse
5	Connector Key Marking	10	+ Tip

H.1.6 FlexPak6D SMA to TNC Adapter Cable (NovAtel part number 60723154)

The FlexPak6D is supplied with additional SMA to TNC adapter cables, one for each SMA antenna connector.

Figure 104: FlexPak6D SMA to TNC Adapter Cable

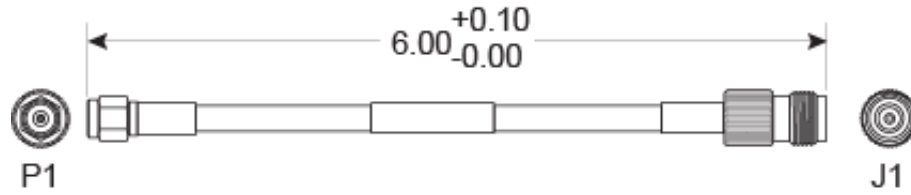

Reference	Description
P1	SMA connector
J1	TNC connector

The following tables list the replacement parts available for your NovAtel OEM6 receiver. For assistance or to order additional components, contact your local NovAtel dealer or Customer Support.

I.1 OEM6 Receiver Cards

Part Description	NovAtel Part
Interface connector for J4101 header on OEM638 (Samtec BSH-050-01-L-D-A)	01019541

I.2 FlexPak6 and FlexPak6D

Part Description	NovAtel Part
I/O breakout cable (<i>Figure 99, I/O Breakout Cable</i> on page 198)	01018649
I/O DB-HD15 strobe cable (<i>Figure 100, I/O DB-HD15 Strobe Port Cable</i> on page 199)	01018651
Straight through serial data cable (<i>Figure 101, Straight Through Serial Cable</i> on page 200)	01018520
Null modem serial data cable (<i>Figure 102, Null Modem Cable</i> on page 201)	01017658
Power cable: LEMO 4-pin socket to 12 V power outlet plug (<i>Figure 103, 12 V Power Accessory Cable</i> on page 202)	01017663
SMA (M) to TNC (F) LMR-195 (outdoor) adapter cable	60723154
USB A to mini B cable (optional accessory for FlexPak6D)	60323078

I.3 Accessories

Part Description	NovAtel Part
Optional NovAtel Antennas:	
Model 702 (L1/L2)	GPS-702
Model 701 (L1-only)	GPS-701
Model 702L (L1/L2/L-Band, B1 BeiDou)	GPS-702L
Model 702GG (L1/L2/GLONASS)	GPS-702-GG
Model 701GG (L1/GLONASS)	GPS-701-GG
Model 703GGG (L1/L2/L5 GPS, L1/L2/L3 GLONASS, B1/B2 BeiDou, E1/E5a-b Galileo)	GPS-703-GGG
Model GPS-704 (GPS L1/L2/L5, Galileo E1/E5a/E5b/E6 and GLONASS L1/L2, TNC connector), B1/B2/B3 BeiDou	GPS-704-X
Model 702GGL (L1/L2/GLONASS/L-Band, B1 BeiDou)	GPS-702-GGL
Model 701GGL (L1/GLONASS/L-Band, B1 BeiDou)	GPS-701-GGL

Part Description	NovAtel Part
Model 35C50P1GLA (L1/GLONASS/L-Band)	ANT-35C50P1GLA-TW-N
Model 26C1GA (L1)	ANT-26C1GA-TBW-N
Model 42G1215A (L1/L2/L-Band)	42G1215A-XT-1-2 and 42G1215A-XT-1-3
Model C2GA (L1/L2)	ANT-C2GA-TW-N
Model 42G1215A (L1/L2)	42G1215A-XT-1
Optional RF Antenna Cable:	
5 metres	GPS-C006
15 metres	GPS-C016
30 metres	GPS-C032

I.4 Manufacturers' Part Numbers

The following original manufacturer's part numbers are provided for information only and are not available from NovAtel as separate parts.

Product	Part Description	Company	Part Number
OEM615 card (Figure 10, OEM615 Connector and Indicator Locations on page 35)	J101, MCX jack receptacle	Samtec	MCX-J-P-H-ST-SM1
OEM617 card (Figure 11, OEM617 Connector and Indicator Locations on page 36)	P1101, 2 x 10 header, 2 mm pitch	Samtec	TMM-110-03-G-D
OEM617D card (Figure 12, OEM617D Connectors and Indicators on page 36)	J100 & J101, MMCX jack receptacle	Johnson	135-3701-201
		Samtec	RSP-149374-01
OEM628 card (Figure 13, OEM628 Connector and Indicator Locations on page 37)	J100 & J101, MMCX jack receptacle	Johnson	135-3701-201
		Samtec	RSP-149374-01
	P1500, 2x12 header, 2 mm pitch	Samtec	TMM-112-03-G-D
	P1502, 2x8 header, 2 mm pitch	Samtec	TMM-108-03-G-D
OEM638 card (Figure 14, OEM638 Connector and Indicator Locations on page 38)	P4001 (main header)	Samtec	TSM-120-01-S-DV-A-P
	J3201 (Ethernet header)	Samtec	SQW-105-01-L-D-VS-K-A
	J4101 (Expansion header)	Samtec	BSH-050-01-L-D-A

J.1 Overview

Static electricity is electrical charge stored in an electromagnetic field or on an insulating body. This charge can flow as soon as a low impedance path to ground is established. Static sensitive units can be permanently damaged by static discharge potentials of as little as 40 volts. Charges carried by the human body, which can be thousands of times higher than this 40 V threshold, can accumulate through as simple a mechanism as walking across non-conducting floor coverings such as carpet or tile. These charges may be stored on clothing, especially when the ambient air is dry, through friction between the body and/or various clothing layers. Synthetic materials accumulate higher charges than natural fibers. Electrostatic voltage levels on insulators may be very high, in the order of thousands of volts.

Various electrical and electronic components are vulnerable to ESD. These include discrete components, hybrid devices, Integrated Circuits (ICs) and Printed Circuit Boards (PCBs) assembled with these devices.

J.2 Handling ESD Sensitive Devices

ESD sensitive devices must only be handled in static controlled locations. Some recommendations for such handling practices follow:

- Handling areas must be equipped with a grounded table, floor mats and wrist strap.
- A relative humidity level must be maintained between 20% and 80% non-condensing.
- No ESD sensitive board or component should be removed from its protective package, except in a static controlled location.
- A static controlled environment and correct static control procedures are required at both repair stations and maintenance areas.
- ESD sensitive devices must be handled only after personnel have grounded themselves via wrist straps and mats.
- Boards or components should never come in contact with clothing, because normal grounding cannot dissipate static charges on fabrics.
- A circuit board must be placed into a static shielding bag or clamshell before being removed from the work location and must remain in the protective enclosure until it arrives at a static controlled repair/test center.
- Circuit boards must not be changed or moved needlessly. Handles may be provided on circuit boards for use in their removal and replacement; care should be taken to avoid contact with the connectors and components.
- On-site repair of ESD sensitive equipment should not be undertaken except to restore service in an emergency where spare boards are not available. Under these circumstances repair station techniques must be observed. Under normal circumstances a faulty or suspect circuit board must be sent to a repair center having complete facilities or to the manufacturer for exchange or repair.
- Where protective measures have not been installed, a suitable alternative would be the use of a Portable Field Service Grounding Kit (for example, 3M Kit #8501 or #8507). This consists of a portable mat and wrist strap which must be attached to a suitable ground.
- A circuit board in a static shielding bag or clamshell may be shipped or stored in a cardboard carton, but the carton must not enter a static controlled area such as a grounded or dissipative bench top or repair zone. Do not place anything else inside the bag (for example, repair tags).
- Treat all PCBs and components as ESD sensitive. Assume that you will damage the PCB or component if you are not ESD conscious.
- Do not use torn or punctured static-shielding bags. A wire tag protruding through the bag could act as a "lightning rod", funneling the entire charge into the components inside the bag.

- Do not allow chargeable plastics, such as binders, within 0.6 m of unshielded PCBs.
- Do not allow a PCB to come within 0.3 m of a computer monitor.

J.3 Prime Static Accumulators

Table 55, *Static-Accumulating Materials* on page 207 provides some background information on static accumulating materials.

Table 55: Static-Accumulating Materials

Work Surfaces	<ul style="list-style-type: none"> • formica (waxed or highly resistive) • finished wood • synthetic mats • writing materials, note pads and so on
Floors	<ul style="list-style-type: none"> • wax-finished • vinyl
Clothes	<ul style="list-style-type: none"> • common cleanroom smocks • personal garments (all textiles) • non-conductive shoes
Chairs	<ul style="list-style-type: none"> • finished wood • vinyl • fiberglass
Packing and handling	<ul style="list-style-type: none"> • common polyethylene bags, wraps, envelopes and bubble pack • pack foam • common plastic trays and tote boxes
Assembly, cleaning and repair areas	<ul style="list-style-type: none"> • spray cleaners • common solder sucker • common soldering irons • common solvent brushes (synthetic bristles) • cleaning, drying and temperature chambers

J.4 Handling Printed Circuit Boards

ESD damage to unprotected sensitive devices may occur at any time. ESD events can occur far below the threshold of human sensitivity. Follow this sequence when it becomes necessary to install or remove a circuit board:

1. After you are connected to the grounded wrist strap, remove the circuit board from the frame and place it on a static controlled surface (grounded floor or table mat).
2. Remove the replacement circuit board from the static-shielding bag or clamshell and insert it into the equipment.
3. Place the original board into the shielding bag or clamshell and seal it with a label.
4. Do not put repair tags inside the shielding bag or clamshell.
5. Disconnect the wrist strap.

