

RSS-233 - 8K Truck

Self-Steering – Auxiliary Axle Suspension



Installation and Service Manual

Suspension Identification 2

Suspension System Serial Tag

Installation 3

Prior to Installation

Torque Specifications

Suspension Mounting

Air Controls - Troubleshooting

Maintenance 7

Recommended Service Intervals

Parts Illustration

8K Truck Suspension

Westport Kingpin Axle Assembly

Kaiser Kingpin Axle Assembly

Bushing Replacement Kit

Bushing Replacement Procedure

Warranty 12



Part No.: 9710101

Doc.: 233-Truck-8K-ISM-RevD-04-04-19

SUSPENSION IDENTIFICATION

Introduction

The Ridewell Self-Steering (RSS) 233 Suspension series is a fully integrated, auxiliary axle suspension system available for truck and trailer applications.

The RSS-233 8K Truck Suspension can be purchased with a Kaiser® kingpin system for extended service life and lower maintenance.

Refer to the engineering drawing for detailed information on the suspension system components and operating parameters.

Suspension Identification Tag

A (606-) **Installation/Assembly Number** will be listed as the **Part Number** when other system components are factory installed with the suspension (Figure 1).

The **Suspension Number** and **Serial Number** on the Suspension ID Tag refer to the model and the date of manufacture of an individual suspension system.

Please refer to the suspension number/part number and serial number on the Suspension Identification Tag when contacting Ridewell for customer service, replacement parts and warranty information.

Notes and Cautions

All work should be completed by a properly trained technician using the proper/special tools and safe work procedures.

Read through the entire Installation and Service Manual (ISM) before performing any installation or maintenance procedures.

The ISM uses two types of service notes to provide important safety guidelines, prevent equipment damage and make sure that the suspension system operates correctly.

The service notes are defined as:

“NOTE”: Provides additional instructions or procedures to complete tasks and make sure that the suspension functions properly.

CAUTION Indicates a hazardous situation or unsafe practice that, if not avoided, could result in equipment damage and serious injury.

 RIDEWELL SUSPENSIONS The Engineered Suspension Company	
PART NO:	
SUSP. NO:	
SERIAL NO:	
GROSS AXLE WEIGHT RATING CERTIFICATION IS PER THE FINAL STAGE MANUFACTURER OR ALTERER.	
THIS PRODUCT MAY BE COVERED UNDER ONE OR MORE PATENTS, ADDITIONAL PATENTS MAY BE PENDING.	
www.ridewellcorp.com	(800) 641-4122

Figure 1.

The Suspension Model (Suspension Number) and the date of manufacture (Serial Number) are listed on the Suspension Identification Tag.

Notes on Self-Steering Option

Self-steering suspensions are designed to steer only in the forward direction. The suspension should be raised off the ground during reverse travel to avoid damaging the suspension.

Ridewell Suspensions strongly recommends the use of automated systems that raise the lift-axle during reverse travel. For manual operations, Ridewell recommends the installation of a visual/audible indicator to assist the driver.

CAUTION Failure to lift the suspension during reverse travel can cause component damage and void the suspension warranty.

Prior to Installation

Refer to the engineering drawing to confirm dimensional requirements and the range of ride heights available.

Installations can vary and procedures should be adapted for different vehicles, as needed.

- The Gross Axle Weight Rating (GAWR) is determined by the system component with the lowest load rating. Please consult with tire, wheel, axle and brake manufacturers before installation to determine the GAWR.
- If vehicle chassis modifications are required, consult with the vehicle manufacturer to ensure that such changes are permitted.
- Welding or altering suspension components is not permitted without the express written permission of Ridewell Suspensions.

Installer Responsibilities

The installer of the suspension has the sole responsibility for proper attachment of the suspension system to the vehicle chassis.

- The installer is responsible for locating the suspension system on the vehicle to provide the proper load distribution.
- The installer must verify that vehicle crossmembers are positioned to support the suspension at the installing location.
- It is the installer's responsibility to determine that axle spacing conforms to any applicable federal and local bridge laws.
- The installer must verify that air reservoir volume requirements are met after suspension installation. Consult the vehicle manufacturer or Federal Motor Vehicle Safety Standards (FMVSS) 121 for more information.
- The installer must verify there is sufficient clearance for proper functioning of the auxiliary suspension, air springs, brake chambers, steering components, axle (including axle to driveline clearance) and tires.

RSS-233 - 8K Truck Suspension - Torque Specifications

Fastener Type	Size	Torque Values	
		foot-pound	Newton-meter
Flanged Lock Screw	3/8"-16NC	25 ft-lb	35 N-m
Locknut (Air Spring)	3/4"-16NF	50 ft-lb	68 N-m
Locknut (Steering Damper)	3/4"-10NC	160 ft-lb	217 N-m
Pivot Bolt - (Hex Head Cap Screw (HHCS)) Pivot Nut - (Locknut)	3/4"-16NF	310 ft-lb	420 N-m

Torque values reflect a lubricated thread condition (Nuts are pre-lubed). Do not overtorque.

⚠ CAUTION Suspension is shipped with minimal torque applied to fasteners. It is the installer's responsibility to apply the proper torque values. All fasteners **MUST** be re-torqued after the first 6,000 miles of operation. Failure to install and maintain suspension component fasteners at torque specifications could result in suspension failure and void the warranty.

Mounting the suspension to the frame

Refer to the engineering drawing for the range of ride heights available as well as spacing and clearance requirements of the suspension.

All models of the RSS-233 8K Truck Suspension are shipped fully assembled. If the suspension system is taken apart for installation, the components must be reassembled with the proper torque applied (Page 3).

Bolt-On Installation Procedure

Suspension hangers are attached to the vehicle frame with six 5/8-inch Grade 8 bolts in each hanger. Air spring mounting brackets require two 5/8-inch Grade 8 bolts in each bracket. Flanged locknuts or locknuts with hardened washers are required.

- Hanger locator flanges are pre-installed to match the ride height set by the air spring mounting plate. Ride height is adjusted by installing a 1" or 2" spacer on the air spring mounting plates. The hanger locator flange is moved up or down on the hanger to match the height of the air spring mounting plate and spacer installation.

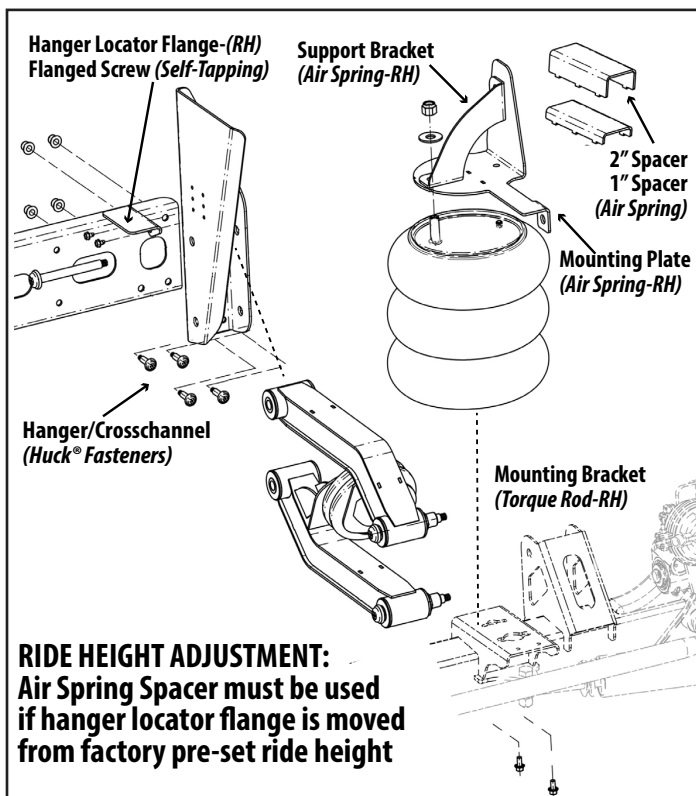

1. Measure the vehicle frame width and the hanger-to-hanger inside dimensions of the suspension. Customer-supplied filler plates are required for the hangers and air spring mounting brackets if the vehicle frame width is narrower than that of the suspension.
2. Place the suspension (with hanger and air spring filler plates and appropriate spacer(s), if required) in desired location. NOTE: A crossmember must be located on the frame within six inches of the leading or trailing edge of the hanger.
3. Check that the location provides adequate clearance for suspension components. Make sure the top of the hangers and air spring mounting plates are parallel to the chassis frame to maintain the proper caster angle.
4. Hangers and air spring mounting plates should be perpendicular to the chassis frame and in alignment with each other. Clamp the hangers, mounting plates, and spacer and filler plates (if required) firmly in place.
5. Refer to the engineering drawing for the recommended bolt hole locations on the hangers and air spring mounting plates. If it is not possible to use the recommended bolt locations, space the bolt holes as far apart as possible to provide the greatest support for the suspension.
CAUTION Check to make sure that wires, hoses or other components located within the frame rail are not affected by drilling.
6. Center punch and drill six bolt holes in each hanger. Bolt each hanger to the frame with six 5/8-inch Grade 8 bolts and locknuts.
7. Center punch and drill two bolt holes in each air spring mounting bracket. Bolt each air spring bracket to the frame with two 5/8-inch Grade 8 bolts and locknuts.
8. Install/connect the air control kit (ACK) to the suspension (Page 6). Check the air system after installation for leaks and proper operation of controls.
9. Perform final assembly and inspection and check the wheel toe setting (Page 5)

CAUTION Failure to torque bolts/nuts of suspension components to specifications can result in failure of the suspension and void the warranty.

Final Assembly and Inspection

1. Verify that all suspension component bolts/nuts are torqued to specifications (Page 3).
2. Install wheels and tires.
CAUTION When lowering an auxiliary axle on an unloaded vehicle, pressure to the load air springs must be reduced to below 10 psi. Failure to reduce the air pressure could cause the vehicle's drive axles to rise from the ground and the vehicle could roll in an unsafe manner.
3. Check that tires are inflated to recommended pressure. Check wheel hubs for proper level of lubricant recommended by the manufacturer.
4. Lift the axle to the raised position. Check the air system tubing and connections for leaks.
5. Check that wheels can rotate freely and that brakes and slack adjusters are properly adjusted.
6. Raise and lower the suspension assembly (wheels and tires installed) through the entire range of travel. Make sure that sufficient clearances for air springs, brake chambers and other components has been provided.
7. Check the vehicle's reverse travel options:
Check automated system (if installed) to make sure that suspension raises during reverse travel.

CAUTION Failure to check reverse travel operations can result in component damage and void the suspension warranty.

CAUTION Do not lower the auxiliary axle while the vehicle is moving above 10 mph.

Check wheel toe-in setting and adjust, if necessary (between 1/32" and 3/32").

Wheel Toe Setting

Wheel toe is the relationship of the distance between the front of the tires and the distance between the rear of the tires on the same axle. When the front distance is less than the rear distance, the wheels are in a "toe-in" (positive toe) condition.

The correct setting for the RSS-233 suspension should be a positive toe-in between 1/32" and 3/32".

Regulate load with air spring pressure

The load capacity of the auxiliary axle is adjusted by increasing or decreasing the pressure to the air springs. By applying more air, the lift axle takes on a greater percentage of the load's weight. The load capacity is decreased as the air pressure decreases.

Accurate readings of the load capacity can be obtained by parking a loaded vehicle over a calibrated scale and lowering the axle onto the scale. The air pressure to the air springs is manually adjusted up or down to obtain the axle load weight at various air pressures.

CAUTION Do not exceed the rated load capacity of the suspension system or other components. Exceeding the capacity can cause component failure and void the warranty.

Check Wheel Toe Setting

1. Deflate the air springs.
2. Lift the axle enough for tires to rotate freely. Support with jack stands to ensure axle is level.
3. Position tires to point straight ahead. Spin each tire. Use a piece of chalk to mark a line on the center tread all the way around each tire.
4. Use a tape measure to measure the distance between the center mark at the front and the rear of the tires.
5. Subtract the distance measured at the front of the tires from the distance measured at the rear of the tires to obtain the wheel toe setting (between 1/32" and 3/32").

Adjust Wheel Toe

1. Loosen the clamps on both ends of the tie rod. Twist the tie rod forward/backward to move the front of the tires towards or away from each other (increase/decrease toe-in setting).
2. Continue rotating the tie rod until the proper toe-in setting is achieved.
3. Torque tie-rod clamps to 60-80 ft-lb (81-108 N-m).

Install air system components

Connect the load and lift air springs and an air control kit to the air system (Figure 2).

The air control kit (ACK) consists of a pressure regulator with a gauge connected to an air valve controlled by an electric switch or manual knob. The ACK allows the operator to control the air spring pressure so that the auxiliary axle can support different loads.

Ridewell has a number of manual/electric ACK configurations available. Installation will vary by the type of configuration.

CAUTION The installer is responsible for making sure that air system requirements comply with the appropriate Federal Motor Vehicle Safety Standards.

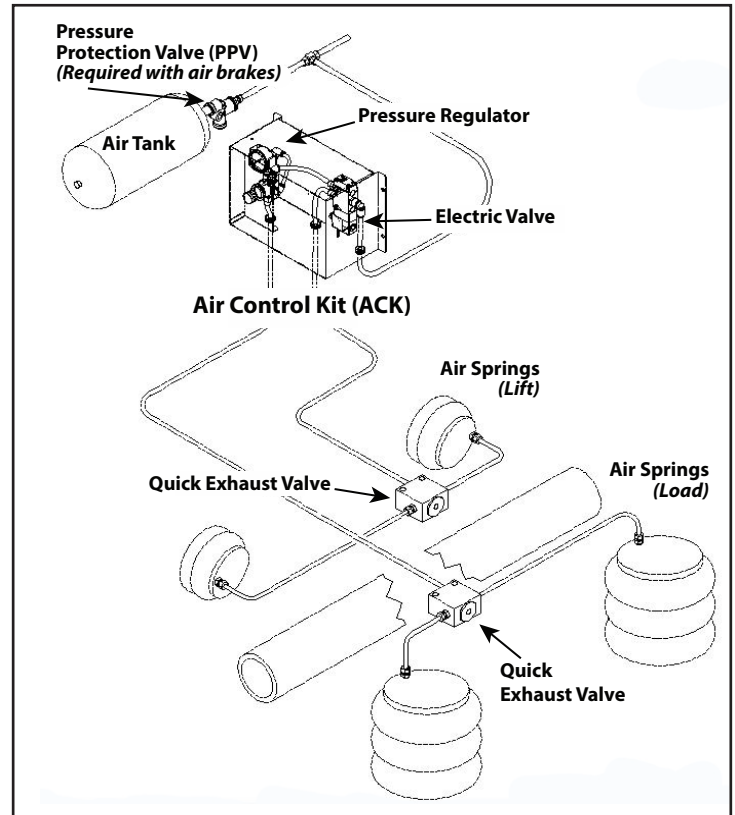

Figure 2.
Example of Air Control Kit (ACK) installation

Troubleshooting – Air System Installation

Problem	Possible Cause	Solution
Air springs fill but do not exhaust.	<ul style="list-style-type: none"> – Obstructed air line. – Faulty controls wiring. – Manual override pushed in 	<ul style="list-style-type: none"> – Check for pinched/blocked lines. – Check wiring with voltmeter and correct wiring/installation. – Release manual override.
Air system leaks down after a short period of time.	<ul style="list-style-type: none"> – Leak in air system beyond accepted standards. 	<ul style="list-style-type: none"> – Pressurize system and spray soap water solution onto the tubing, valves and fittings. Check for bubbles (leaks). Note: Some valves will leak at an acceptable rate. – Check that tubing cuts are straight and smooth. Re-cut and reassemble fitting joints, if necessary.
Auxiliary unit will not stay up	<ul style="list-style-type: none"> – Loose Air Fittings. – Damaged Air Lines. – Air lines to lift and load air springs are reversed. – Damaged or Worn Air Springs. 	<ul style="list-style-type: none"> – Check and retighten fittings. Repair or replace component, as necessary. – Check installation. Air line from regulator goes to (load) air springs. – Replace if worn or damaged.
Auxiliary unit not getting the correct lift	<ul style="list-style-type: none"> – Air lines to lift and load air springs are reversed. – Lift air springs do not have proper air pressure. – Interference with driveline or other chassis components. – Air control system not installed correctly. 	<ul style="list-style-type: none"> – Check installation. Air line from regulator goes to (load) air springs. – Check for loose fittings or worn/damaged lines. Verify air tank pressure with gauge. – Visually inspect unit operation for proper clearance. Check for loose fasteners and retighten. – Check installation; refer to OEM installation procedures.

A visual inspection of the suspension structure should be performed during each pre-trip/safety inspection. Ridewell Suspensions recommends the following minimum service intervals for standard duty, on-highway usage applications. More frequent intervals are recommended for heavier duty applications.

Daily/Pre-Trip Inspections

- ___ Check tires for proper inflation, damage or excessive wear.
- ___ Check wheel-ends for obvious signs of lubricant leakage. Check for missing components.
- ___ Visually inspect suspension structure for signs of damage or excessive wear.
- ___ Check for loose or missing bolts/nuts. Check for irregular movement in suspension components.
- ___ Make sure air controls are operating properly. Drain all moisture from air reservoirs.

First 6,000 miles of use

- ___ Torque all suspension bolts/nuts to specifications (torque values chart on Page 3).

Every 12,000 miles of use

- ___ Lubricate Brake Cam and Slack Adjuster.
- ___ Inspect kingpins and upper/lower kingpin bushings for wear. Grease thrust bearings.
- ___ Inspect steering damper for damage/wear.
- ___ Inspect air springs for any damage or excessive wear. Torque air spring bolts/nuts to specifications (Page 3).
- ___ Check air system for leaks.

First 50,000 miles of use

- ___ Torque all suspension bolts/nuts to specifications (Page 3).
- ___ Check wheel ends for excessive play.
- ___ Check suspension pivot bushings for wear.
- ___ Check operation of (reverse) steering lock (if equipped).
- ___ Verify operation of manual/automatic lift-in-reverse control (if equipped).
- ___ Inspect tie-rod and tie-rod ends for damage and wear. Lubricate tie-rod ends. Check that the tie-rod boot is in place and completely over the end of the tie-rod. Replace entire tie-rod end if boot is damaged.

Annually/100,000 miles of use

- ___ Inspect pivot connections for worn pivot bushings and replace, if necessary. Torque pivot hardware and component bolts/nuts to specifications (Page 3).
- ___ Check suspension hanger and air spring mounting plate connections to frame.
- ___ Check lubrication level in wheel ends:
 - 1) Oil-Filled Wheel Ends: Refill/Replace lubricant as needed (Refer to TMC RP 631 "100K/Annual Inspection").
 - 2) Semi-Fluid Grease: Pull outer bearing and visually inspect lubrication level. Refill/Replace as needed (Refer to TMC RP 631 "Level 3 Lubrication Level Inspection" and TMC RP 618 "Wheel Bearing Adjustment Procedure").
- ___ Check air system for leaks.
- ___ Test air system pressure protection valve (if equipped).
- ___ Check brake chambers and brakes for damage and proper function.

⚠ CAUTION Failure to exhaust all pressure from the air system before working on the vehicle can cause serious injury.

⚠ CAUTION Failure to torque bolts/nuts of suspension components to specifications can result in failure of the suspension and void the warranty.

Refer to the following Technology & Maintenance Council (TMC) publications for additional maintenance information.

TMC RP 609	Self-Adjusting and Manual Brake Adjuster Removal, Installation and Maintenance
TMC RP 618	Wheel Bearing Adjustment Procedures
TMC RP 619	Air System Inspection Procedure
TMC RP 622	Wheel Seal and Bearing Removal, Installation, and Maintenance
TMC RP 631	Recommendations for Wheel End Lubrication
TMC RP 643	Air Ride Suspension Maintenance Guidelines
TMC RP 645	Tie Rod End Inspection and Maintenance Procedure
TMC RP 651	Steer Axle Maintenance Guidelines

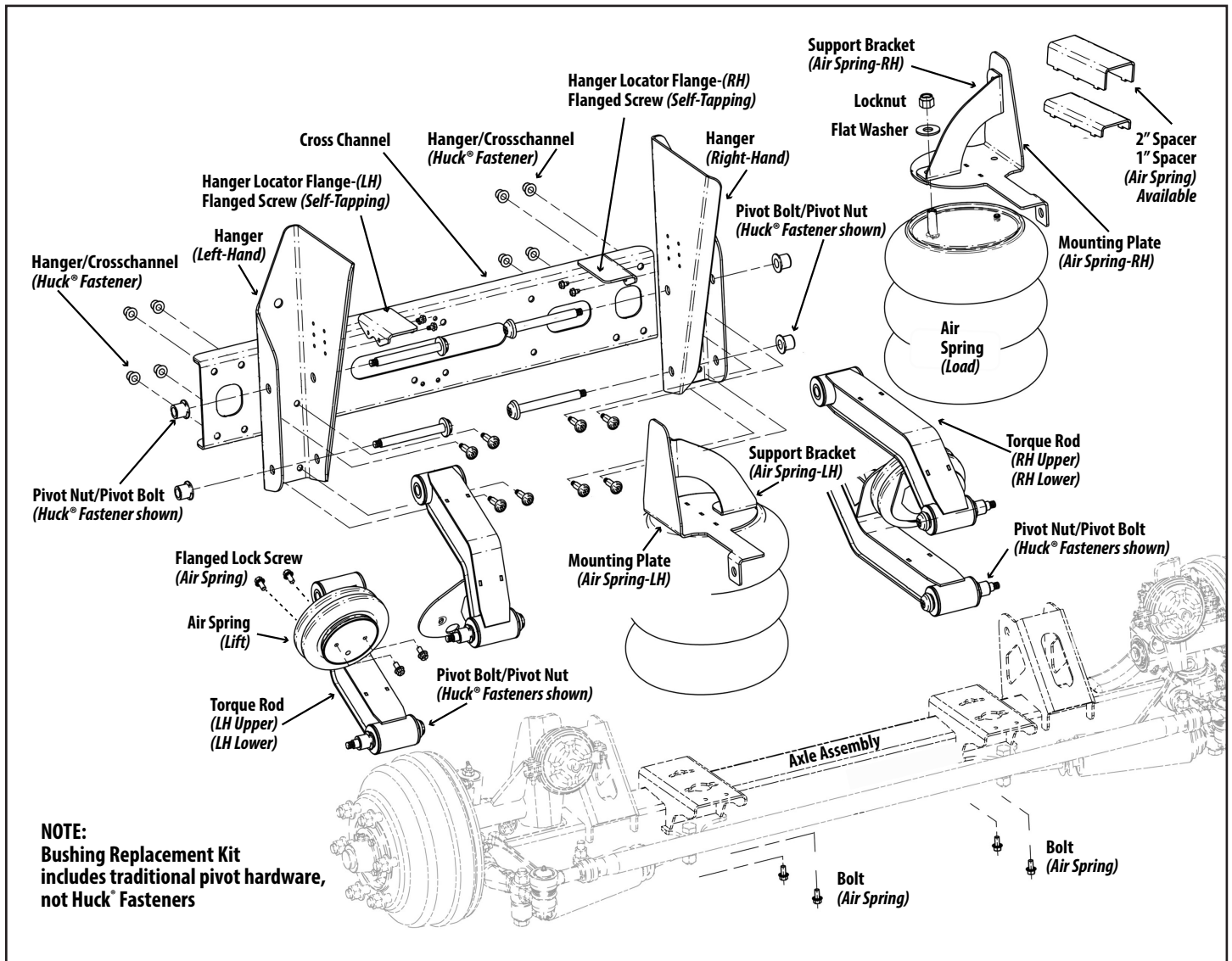

Figure 3.
RSS-233 - 8K Truck Suspension
 Refer to the engineering drawing for the individual component part number.

Figure 4.
RSS-233 - 8K Truck Suspension
Kaiser® Kingpin – Axle Assembly

Refer to the engineering drawing for the individual component part number.

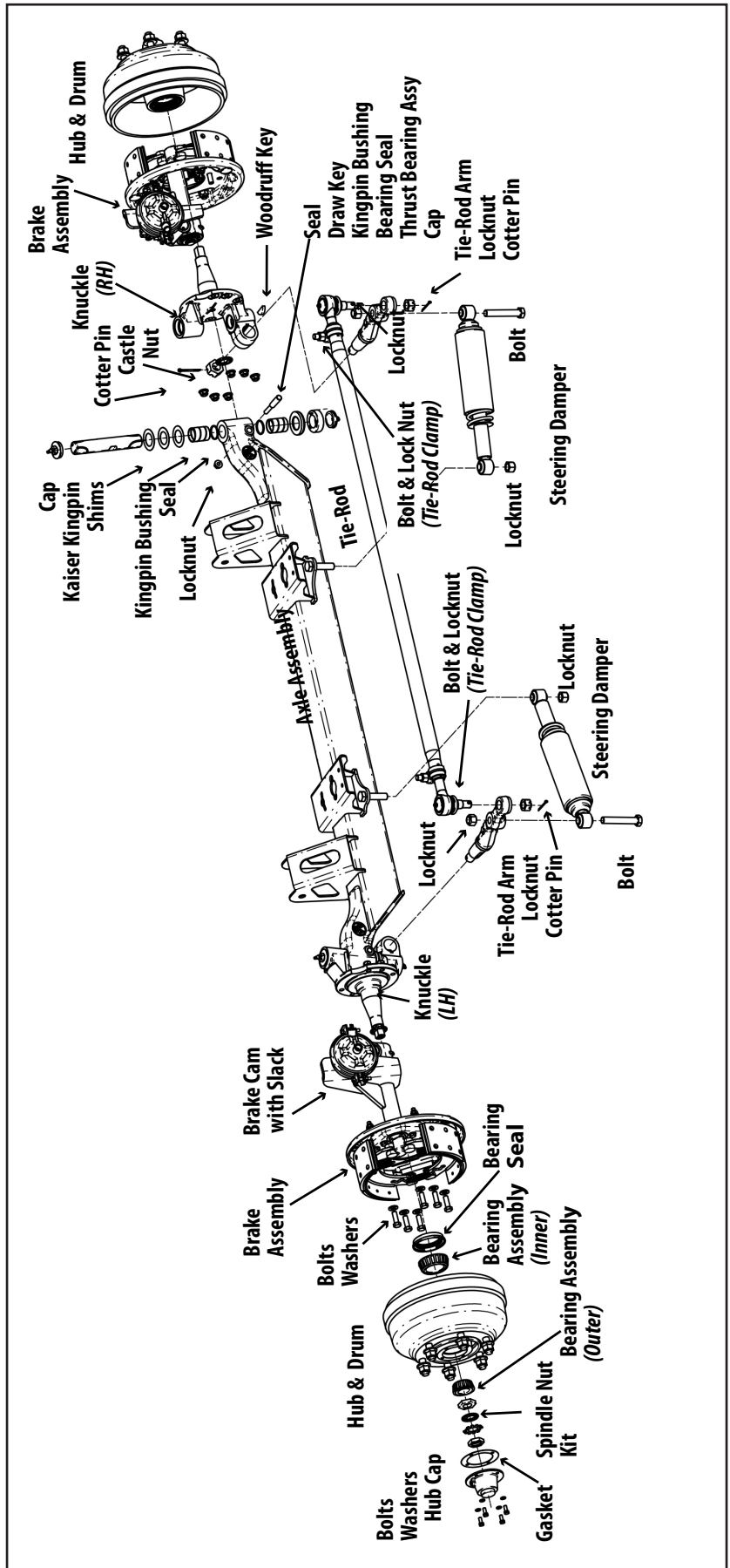
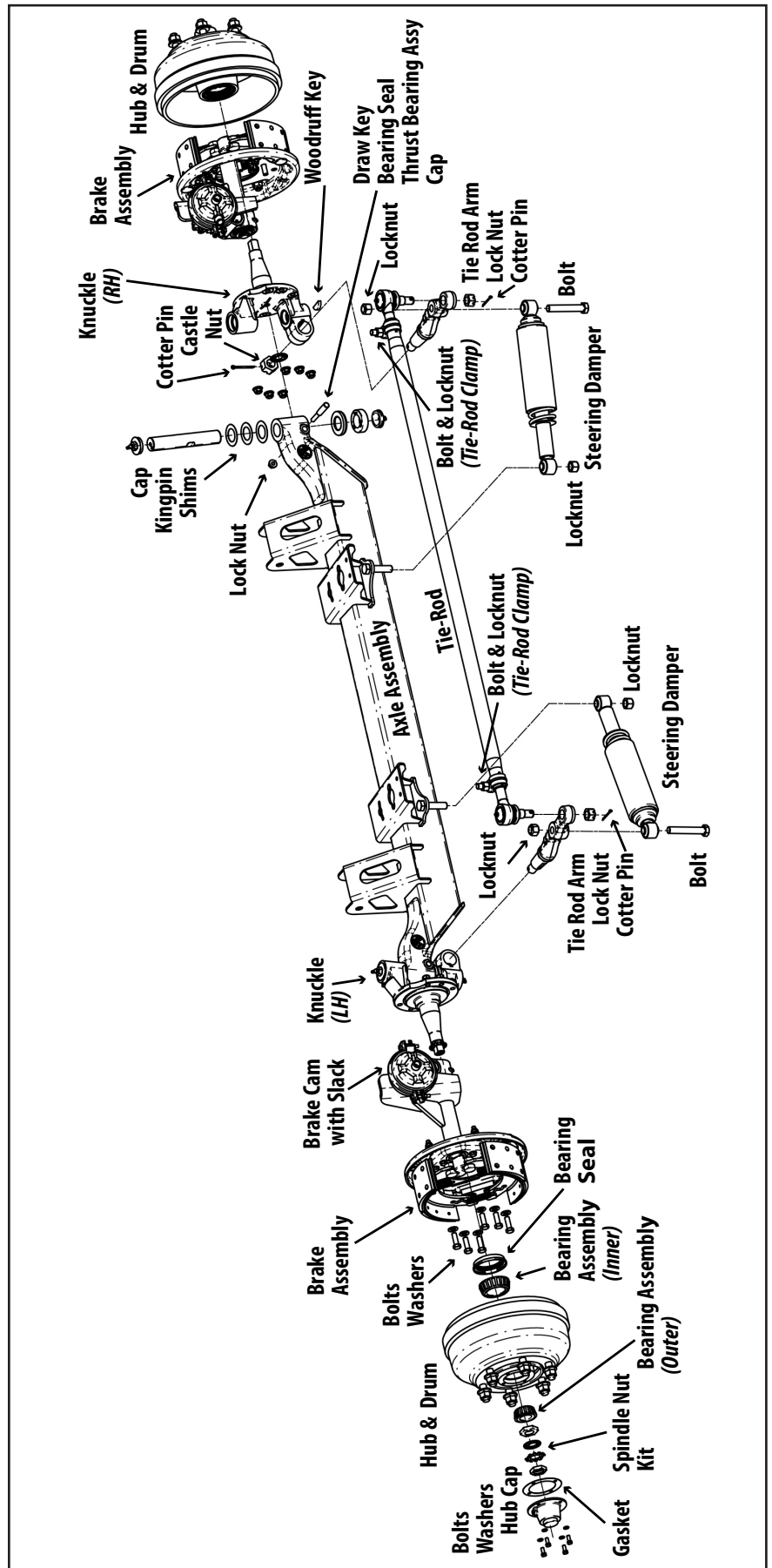

Figure 5.
RSS-233 - 8K Truck Suspension
Westport Kingpin - Axle Assembly

Refer to the engineering drawing for the individual component part number.



RSS-233 - 8K Truck Suspension - Bushing Replacement Kit

Suspension Type	Replacement Kit Part Number	Pivot Hardware	Torque Values	
			foot-pound	Newton-meter
All models	6040133	Bushing kit-No Hardware	310 ft-lb	420 N-m
All models	6040134	Pivot Bolt (HHCS) Pivot Nut (Locknut)	310 ft-lb	420 N-m

CAUTION Failure to install and maintain pivot hardware at torque specifications could result in suspension failure and void the warranty. Refer to the engineering drawing for torque specification.

Park the vehicle on a level surface. Chock wheels to keep vehicle from moving. Exhaust all air from the air system. Disassemble suspension, if necessary, to reach pivot connections.

CAUTION Failure to properly chock wheels and exhaust the air system could allow vehicle/suspension movement that could result in serious injury.

Bushing Replacement Procedure

Bushings should be replaced in the eight (8) pivot connections at the same time (Figure 6).

The bushing replacement kit with pivot hardware includes traditional hardware to replace the Huck® Fasteners used for initial assembly.

1. Remove the pivot bolt by cutting/grinding away the Huck® Collar. Discard pivot bolt.
2. Remove the bushing and sleeve assembly from the rod eye. Clean the rod eye of any foreign debris/corrosion.
3. Apply Energy Suspensions® Formula 5 Prelube to the bore (inside) of each bushing half. NOTE: Do not substitute - lubricant included with bushing replacement kit.
4. Press bushing halves into the pivot connection. NOTE: Rubber mallet may be needed.
5. Press the bushing sleeve into the center opening of the installed bushing. NOTE: Rubber mallet may be needed.
6. Check that internal sleeve is flush with both sides of replacement bushing.
7. Install pivot hardware and torque to specifications (Page 3).

CAUTION Failure to torque pivot hardware can result in suspension failure and void the suspension warranty.

8. Reassemble suspension, if necessary.
9. Check wheel toe-in setting and adjust, if necessary (between 1/32" and 3/32").

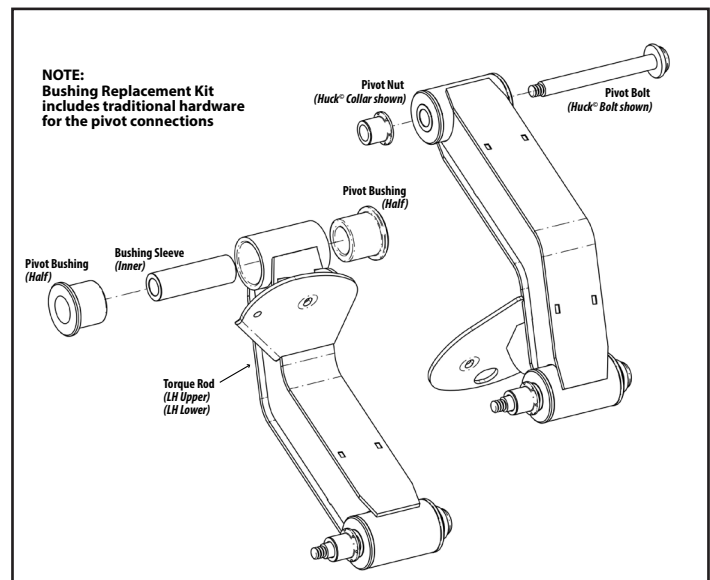

Figure 6. Bushing replacement kit with hardware includes pivot bolt, pivot nut and replacement components for eight (8) pivot connections.

WARRANTY

Terms and coverage in this warranty apply only to the United States and Canada.

Ridewell Suspensions warrants the suspension systems manufactured by it to be free of defects in material and workmanship. Warranty coverage applies only to suspensions that have been properly installed, maintained and operated within the rated capacity and recommended application of the suspension. The responsibility for warranty coverage is limited to the repair/replacement of suspension parts. The liability for coverage of purchased components is limited to the original warranty coverage extended by the manufacturer of the purchased part.

All work under warranty must have prior written approval from the Ridewell warranty department. Ridewell has the sole discretion and authority to approve or deny a claim and authorize the repair or replacement of suspension parts. All parts must be held until the warranty claim is closed.

Parts that need to be returned for warranty evaluation will be issued a Returned Materials Authorization (RMA). Parts must be returned to Ridewell with the transportation charges prepaid. The transportation charges will be reimbursed if the warranty claim is approved.

This non-transferable warranty is in lieu of all other expressed or implied warranties or representations, including any implied warranties of merchantability or fitness or any obligations on the part of Ridewell. Ridewell will not be liable for any business interruptions, loss of profits, personal injury, any costs of travel delays or for any other special, indirect, incidental or consequential losses, costs or damages.

Contact the Ridewell Warranty Dept. at 417.833.4565 - Ext. 135, for complete warranty information.