

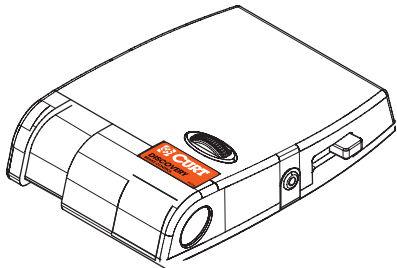

DISCOVERY
BRAKE CONTROL

ELECTRONIC TRAILER BRAKE CONTROL



INSTALLATION AND USER GUIDE

For Use With 12 Volt Negative Ground Systems Only
For Trailers with 2 – 8 Brakes

Read, follow and save this guide for future reference.

51120

This package includes:

- (1) Brake Control Module with Quick Plug
- (1) Mounting Bracket
- (4) Screws

One or more of the following may be needed to complete installation

- Brake Control connection harness supplied with the tow vehicle (if equipped)
- CURT Quick Plug – custom connector for specific vehicles. See catalog for availability
- CURT part number 51515 male Quick Plug with pigtailed
- CURT part number 51500 Brake Control Wiring Kit

Important Features

- Digital display provides detailed brake force output.
- Mount anywhere in your vehicle. Dependable solid state electronics require no leveling.
- Electronic activation ensures smooth stops.
- No internal moving parts.
- Fully adjustable power and time (Sync).
- Provides automatic and manual trailer braking.
- Manual Control activates brake lights.
- Compatible with electronic systems (anti-lock brakes & cruise control).
- Self diagnostic – continually monitors trailer connection & checks for short circuits.

Controls and Components

1. Digital Display
2. Sync adjustment
3. Output adjustment thumbwheel
4. Manual Control lever
5. Quick Plug connector

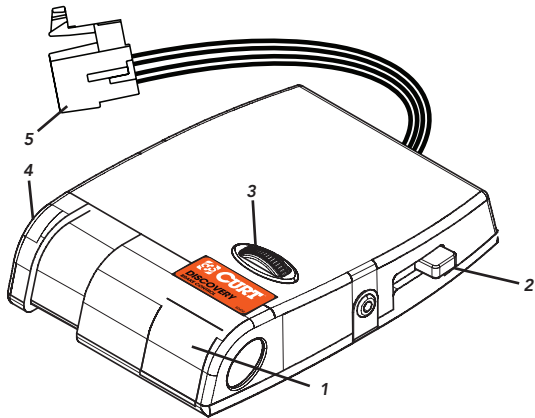

Output Control

The Output Control establishes the maximum amount of power available to the trailer brakes.

As the Output Control is rotated to the right, more power will be available to the brakes when the brake pedal is pressed or the manual control is used.

The Output Control would be adjusted during initial setup, when trailer load changes, when different trailers are used or to adjust for a change in road conditions.

The Output setting is shown on the digital display when a trailer is connected and the brake pedal is pressed or the Manual Control is actuated. The Output setting is shown as 0 through 10 with 0 being the minimum and 10 the maximum.

Sync Control

The Sync Control is located on the right side of the Brake Control Unit.

The Sync Control adjusts trailer brake aggressiveness. The trailer brakes become more aggressive as the switch is moved toward the rear of the tow vehicle.

To view the Sync setting on the display, press the brake pedal (trailer must be connected) and move the Sync Control slightly. The display will change to the Sync mode.

The Sync setting is shown as 10 through 90 with 10 being the least aggressive and 90 being the most aggressive.

The Sync adjustment has no effect on the manual control. The Sync Control would be

adjusted for individual driver preference or changing road conditions.

Manual Control

The Manual Control is located on the front of the Brake Control Unit at the left side.

The Manual Control only applies the trailer brakes. Manual is used during initial setup and in situations where a slow reduction in speed is desirable.

When the Manual Control is pushed to the right, the control begins to apply the trailer brakes. The further to the right it is pushed the harder the brakes are applied until the maximum set by the Output Control is reached.

The Output setting will be shown on the display and can be adjusted when using the Manual Control.

The Manual Control activates the tow vehicle and trailer stoplights.

Digital Display

The Digital display shows the Output setting when the control is activated. It is used to setup and monitor the Brake Control and can be used when trouble shooting.



Control Activated
No Trailer Connected



Control Activated
Trailer Connected



Brake Pedal Pushed
Sync Control Activated
Trailer Connected



Short or Overloaded Brake Circuit
See Trouble Shooting Guide



Internal Control Error
See Trouble Shooting Guide

Mounting the Brake Control Module

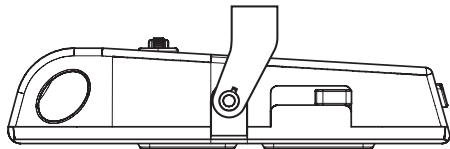

HORIZONTAL

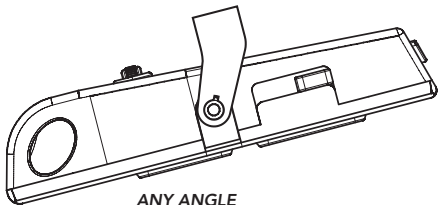

ANY ANGLE

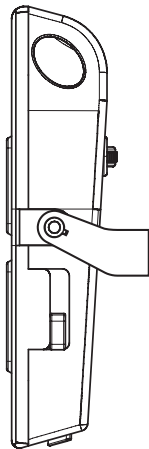

VERTICAL

Note: avoid mounting the Brake Control module near a CB radio or other RF transmitter.

1. Determine a suitable mounting location.
 - A) The unit must be mounted securely to a solid surface.
 - B) The unit must be easily reached by the driver.
 - C) The area behind the mounting location must be clear so nothing will be damaged when drilling.
2. Hold the mounting bracket in the position selected and mark hole locations through the slots in the bracket
3. Using a 1/8" diameter bit, drill holes in the marked locations.
4. With a phillips screwdriver secure the bracket in place using (2) self tapping screws (provided). Be careful not to strip the holes by over-tightening.
5. Mount the brake control unit in the bracket using the (2) machine screws (provided) as shown in the illustration.

Wiring

Note: Removal of factory supplied Quick Plug may void warranty.

Tow Vehicles Equipped with a Factory Brake Control Plug – Most Pickups and utility vehicles are equipped with a plug from the factory that allows quick Brake Control installation. Check the owner's manual for plug availability, location and installation.

If the mating plug supplied with the vehicle is no longer available, a CURT Quick Plug can be used (see CURT catalog for application information).

Tow Vehicles not Equipped with a Factory Brake Control Plug – Suggested: CURT part number 51500 Brake Control Wiring Kit

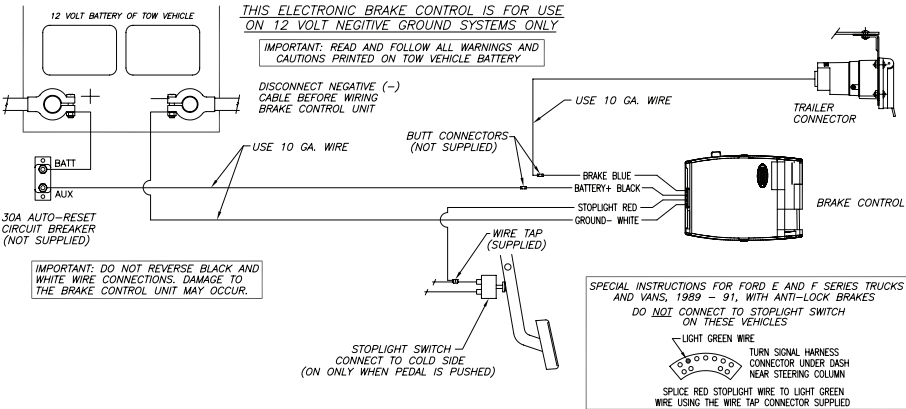

WIRING DIAGRAM

Important: Make sure that both positive and ground connections are made directly to the tow vehicle's battery. Connecting to existing wiring or chassis ground, other than the battery terminal, may damage vehicle circuits and could lead to trailer brake failure.

Mount a 30 amp, auto reset, circuit breaker as close to the battery as possible.

Important: When passing wire through sheet metal, always go through an existing grommet, add a grommet, or use silicone sealer to protect the wire from sharp edges.

Feed two 10 gauge wires, one white and black, from the mounted brake control to the battery area. Using a ring terminal, connect the black wire to the "AUX" side of the 30 amp circuit breaker. Leave the white wire for connection later.

Using a 10/12 gauge butt connector, attach the black wire from the "AUX" side of the 30 amp circuit breaker to the Brake Control module's black wire. Again using a 10/12 gauge butt connector, attach the white wire from the battery area to the module's white wire.

Run a 10 gauge blue wire from the tow vehicle's trailer plug "Brake" terminal to the Brake Control module. Using a 10/12 butt connector, connect this wire to the module's blue wire.

Connect the Brake Control module's red wire to the cold side of the tow vehicle's stoplight switch using a wire tap.

Note: When making the stoplight switch connection on Ford / Mercury vehicles, do not connect to the red wire with green stripe. Connect to the light green wire only.

1989 – 1991 Ford E and F series vans and trucks with anti-lock brakes, find the crescent shaped connector located on the steering column. The connector has two rows of wires, the wire needed is the light green wire, second from the end in the outside row (see the view shown in the wiring diagram).

For all other vehicles, use a test probe to find the cold side of the stoplight switch. Probe the switch wires until a wire is found that is only on when the brake pedal is pressed. **Important: once a cold side wire is found, test to ensure that the wire is not grounded when the pedal is in the up position. If the wire is grounded, the brake control unit will be destroyed when manual control is used.**

Reconnect the tow vehicle's negative battery terminal and attach the white 10 gauge wire previously positioned near the battery to the negative terminal using a ring terminal.

Using 10 gauge stranded wire and a ring terminal, connect the "BATT" side of the circuit breaker to the positive battery terminal.

Secure all loose wires with cable ties so that they will not be damaged and reconnect battery. See vehicle's owner's manual for special re-connection instructions.

Test installation: Without a trailer connected, push the brake pedal. A single . (decimal point) should light up on the Display. If the decimal point does not light or if OL or Er is shown go to the Trouble Shooting section.

Setup

Preliminary Adjustments:

With the trailer connected press and hold the brake pedal, the Display will show the Output setting.

Adjust to 2.0 by turning the Output Control right or left as needed.

While still holding the brake pedal move the Sync Control slightly, the Display will change to the Sync setting. Adjust to 40 by sliding the Sync Control ahead or back as necessary.

Test Drive

In an open area, such as a large parking lot, drive forward and apply the trailer brakes using the Manual Control.

If the trailer brakes are weak adjust the Output Control to the right. If the trailer brakes jerk or lockup adjust the Output Control to the left.

Repeat this step until firm braking is felt without lockup.

Once the Output is set, drive forward and press brake pedal, the tow vehicle and trailer should make smooth stops.

If the stops seems slow and more aggressive braking is desired, move the Sync Control toward the rear of the vehicle while holding the brake pedal.

If the stop seems too aggressive adjust the Sync Control toward the front of the vehicle while holding the brake pedal.

After making a Sync adjustment the Display will show the setting until the brake pedal is released.

Make several stops at various speeds and adjust Sync until stops are smooth and firm. Slight adjustment the Output Control may also be desirable.

NOTE: If any problems occur during Setup refer to the Trouble Shooting section of these instructions.

Helpful Tips

Light pressure on the brake pedal will activate the trailer's brakes with no effect on the tow vehicle's brakes. This is useful for gradual slowing on steep grades or before stops.

Periodic adjustment of the Sync and Output controls may be necessary to correct for changing road conditions, trailer loading, brake wear, and/or driver preference.

In some applications, when towing with Hazard Flashers on, the Digital Display will flash with the Hazard Flashers. If the Brake Control is set aggressively pulsing may be felt in the trailer brakes.

Bench Test Instructions

Wire as shown below.

IMPORTANT: READ AND FOLLOW ALL WARNINGS AND CAUTIONS SHOWN ON BATTERY

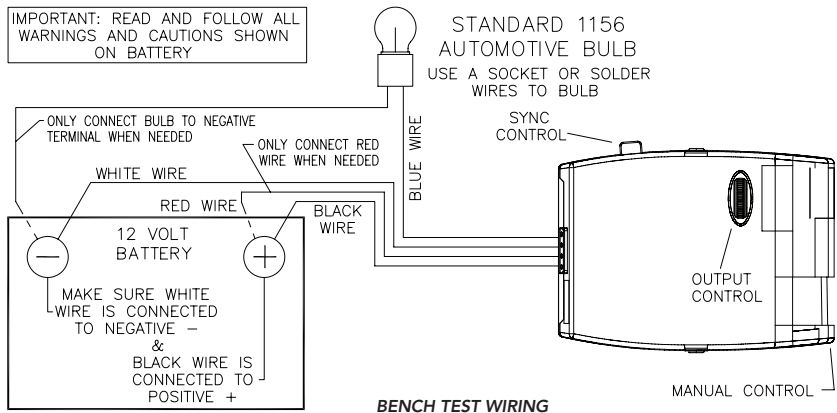

Set the Output control to maximum and set the Sync control to minimum.

NOTE: If at any time during the bench test, the display shows OL make sure that the blue "BRAKE" wire is not shorted to the "NEGATIVE" battery terminal or the white "BATTERY" wire.

If at any time during bench testing, the display shows **Er** return the unit to your CURT dealer for further evaluation.

Test Standby Condition

Hold the red "STOPLIGHT" wire on the "+" battery terminal. The display should show a single decimal point. This indicates correct wiring and that the control is ready.

Disconnect the red "STOPLIGHT" wire from the battery.

Test Brake Pedal Activation

Ground the light bulb to the "NEGATIVE" terminal of the battery. Re-attach the red "STOPLIGHT" wire to the "POSITIVE" battery terminal.

The display should step up to **10** and the bulb should start dim and slowly get brighter.

With the red wire still hooked up, slowly move the Output Control left. The display should count down to **0** and the bulb should dim and go off.

Slowly move the Output Control back to the right, the Display should step up to **10** and the bulb should return to full brightness.

Slowly move the Sync Control to maximum. The display should change to Sync mode and count up to **90**.

Disconnect and reconnect the red wire. The bulb should light brightly with no delay, the display should read **10**.

Disconnect the red wire.

Test Manual Activation

With the Output Control still set at maximum, slowly activate the Manual Control slide button.

The bulb should start dim and get brighter and the display should count up to **10** as the Manual Control is pushed.













While holding the Manual Control all the way in, rotate the Output Control up and down. As the output changes the bulb should go bright and dim and the display should read **0** to **10**.

If the Brake Control unit does not function as described, return it for service or replacement.

Notes:

Trouble Shooting Guide

Test Without Trailer First

	Condition	Display	Probable Cause	Probable Solution
Without Trailer Connected	Decimal point does not light when brake pedal or manual control is used	 Blank	No power to control, to ground, reversed black & white wires, circuit breaker blown	Check and repair connections. Refer to 'wiring' section
	Decimal point does not light when brake pedal is pushed, does light with manual	 Pedal Manual	No connection or incorrect connection at stoplight switch, blown fuse in stoplight circuit	Check and repair connections. Refer to 'wiring' section, check stoplight circuit
	Decimal on all of the time	 Decimal Only	Red wire connected to the wrong side of the stoplight switch or to wrong switch (cruise control)	Check and repair connections. Refer to 'wiring' section
	Display shows output setting	 Output Setting	Brake control unit miswired	Check and repair connections. Refer to 'wiring' section
	Display shows OL when activated	 Flashing OL	Short in blue wire circuit	Locate and correct short
	Display shows Er	 Error	Internal brake control problem	Return unit to dealer for evaluation
With Trailer Connected	No trailer brakes, pedal or manual	 Decimal Only	No connection between brake control and brakes - blue wire circuit	Confirm connection to trailer connector, confirm connector terminal positions, check trailer
	No trailer brakes, pedal or manual	 Output Setting	Miswired trailer connector	Confirm trailer connector terminal position
	No trailer brakes, pedal or manual	 Flashing OL	Short or overload in trailer brakes	Trouble shoot trailer brake circuit per brake manufacturer's instructions
	No trailer brakes, pedal or manual	 Error	Internal brake control problem	Return unit to dealer for evaluation
	Weak or no trailer brakes	 Output Setting	Miswired trailer connector	Check and correct connector positions
	Trailer brakes on all of the time	 Blank	Miswired trailer connector	Check and correct connector positions