

The background of the entire page is a repeating pattern of stylized, white-outlined buildings. The buildings vary in height and style, featuring different window shapes like arched windows, rectangular windows, and dormer windows. Some buildings have gabled roofs, while others have flat roofs with chimneys. The pattern is dense and covers the entire page.

**BUILDERS<sup>®</sup>**  
**EDGE**

# Installation Guide

# **BUILDERS EDGE® INSTALLATION GUIDE**

This guide will show you the products of the Builders Edge family. It provides specific installation steps and application details. Our main goal is to make your installation experience quick, easy and trouble-free.

*Thank you for choosing Builders Edge products.*

**TABLE OF CONTENTS**

Louver/Panel Installation with Screws or Shutter-Loks®.....	4
Board-N-Batten™ Installation.....	5
Shutter Top Installation.....	6
Shutter Hardware.....	7
Ferrule.....	8
Shutter Clip.....	9
Framed Shutter Installation.....	11
Scalloped and Square Dentil.....	12
Dentil Corner.....	14
6" & 9" Window Headers with Keystone.....	15
6" & 9" J-Channel Back Plate for Window Headers.....	18
Pilaster with J-Channel Back Plate.....	20

## LOUVER/PANEL INSTALLATION WITH SCREWS OR SHUTTER-LOKS<sup>®</sup>

### FOR USE ON A VARIETY OF SURFACES INCLUDING:

Wood, aluminum, vinyl, stucco, hardboard, brick or masonry.

### REQUIRED FOR INSTALLATION:

Electric drill, 1/4" drill bit (Shutter-Loks), 11/64" drill bit (screws), hammer, Shutter-Loks and/or screws.

**Note:** Shutters need room to expand/contract, be sure not to over tighten fasteners. To prevent shutters from warping, proper installation must be followed. Wall anchors will be required for shutters installed with screws on any type of masonry.

### STEP 1

Place the shutter next to the window and mark desired location against the wall or window. See Figure 1.

**Note:** Up to 43", use four (4) Shutter-Loks or screws. 44" and greater, use six (6) Shutter-Loks/screws per shutter.

### STEP 2

To help ensure proper alignment, mark and pre-drill holes into the shutter before attaching it to the wall. Holes should be centered within the side rails and in line with the top, bottom and center rails (for six screw application). Shutter-Loks require 1/4" hole, screws require 11/64" hole and 1/4" hole if over 44". See Figures 2A and 2B.

When installing shutters shorter than 44", drill four (4) 1/4" holes in the location shown in Figure 2A. If the shutter is 44" or greater, drill six (6) 1/4" holes for Lok application or four (4) 1/4" holes and two (2) 11/64" holes for screws. See Figure 2B.

### STEP 3

Position the shutter in location against the wall and drill through the shutter into the wall surface to a depth of 3-1/4".

### STEP 4

Tap the Shutter-Lok gently with a hammer or drive in the screw so as not to over drive or over tighten.

### NOTE:

To remove shutters, do not attempt to pull out the Shutter-Loks. Instead, simply slide a pair of snips behind the shutter to cut the Shutter-Lok off at the shank.

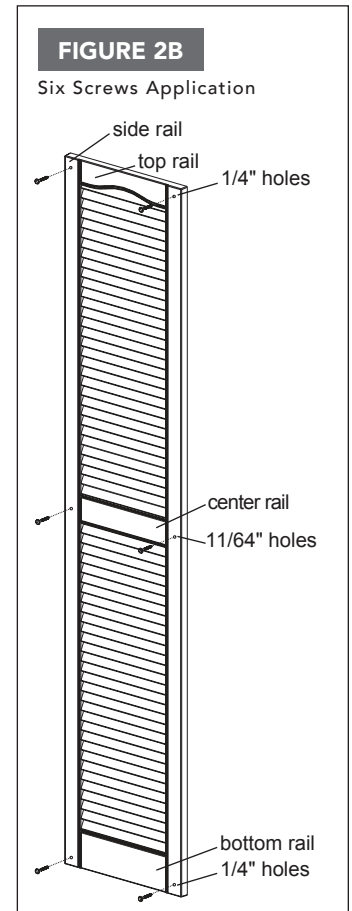
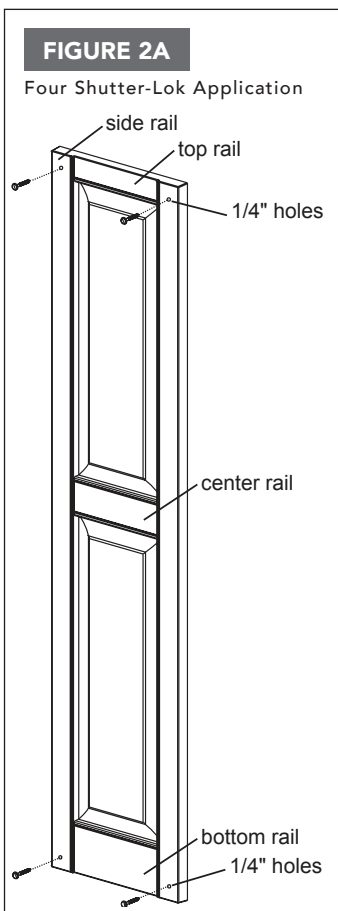
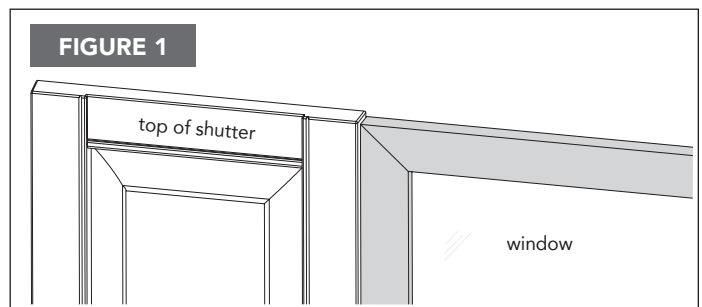

## BOARD-N-BATTEN™ INSTALLATION

### FOR USE ON A VARIETY OF SURFACES INCLUDING:

Wood, aluminum, vinyl, stucco, hardboard, brick or masonry.

### REQUIRED FOR INSTALLATION:

Electric drill, 1/4" drill bit, 11/64" drill bit, screwdriver and screws.

**Note:** Shutters need room to expand/contract, be sure not to over tighten fasteners. To prevent shutters from warping, proper installation must be followed. Wall anchors will be required for shutters installed on any type of masonry.

### STEP 1

Place the shutter next to the window and mark desired location against the wall or window as shown in Figure 1.

**Note:** Up to 43", use four (4) screws. 44" and greater, use six (6) screws per shutter.

### STEP 2

To help ensure proper alignment, mark or pre-drill holes into the shutter before attaching it to the wall. When installing shutters shorter than 43" drill four (4) 1/4" holes in the location shown in "Four Screw Application" as shown in Figure 2A. If shutters are 44" or greater, drill six (4) 1/4" holes and two (2) 11/64" holes in the locations shown in "Six Screw Application" as shown in Figure 2B.

### STEP 3

Use enclosed screws to secure the shutter to the wall surface. Do not over tighten. Shutters must have room to expand and contract with changing weather. Position the shutter in location against the wall, and drill through the shutter into the wall surface to a depth of 3-1/4". These instructions use three-board shutters as the example. The same techniques are used for shutters with four and five boards.

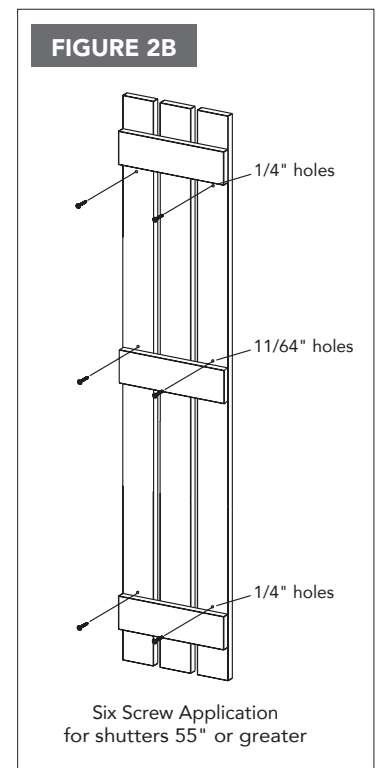
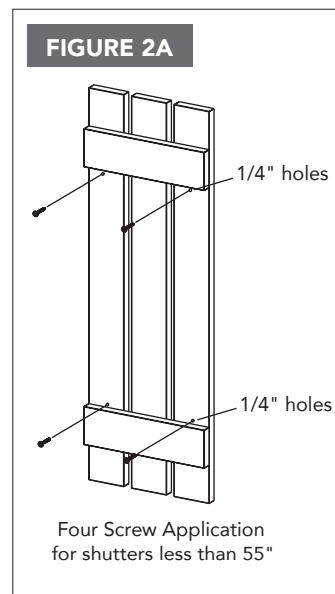
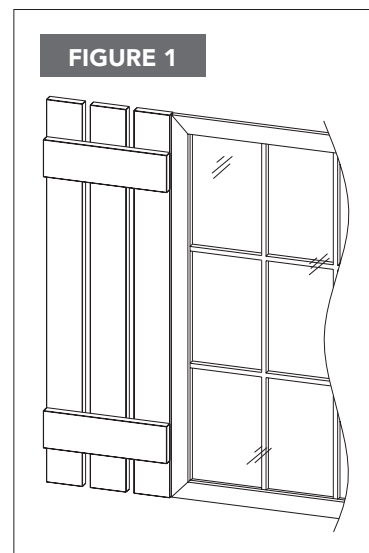

## SHUTTER TOP INSTALLATION

### REQUIRED FOR INSTALLATION:

Electric drill, 1/4" drill bit (Shutter-Loks®), 11/64" drill bit (screws), screwdriver, screws or Shutter-Loks.

**Note:** *Lover and Elliptical tops do not require transom clips.*

### STEP 1

Attach the top to the shutter using the clips provided. Align shutter and top on a flat surface. Join pieces together by pushing each clip on as far as it will go. Use two (2) clips per top. See Figure 1.

Proceed to Step 1A for Raised Panel, Solid and Transom top installation with transom clips.

### STEP 1A

A transom clip will also need to be installed in addition to the two (2) clips. Start by pushing one end of the transom clip onto the shutter, clamping the shutter to the top. Work the transom clip down until the entire clip is fastened to the shutter. Be sure the transom clip is pushed on as far as it will go. See Figure 1.

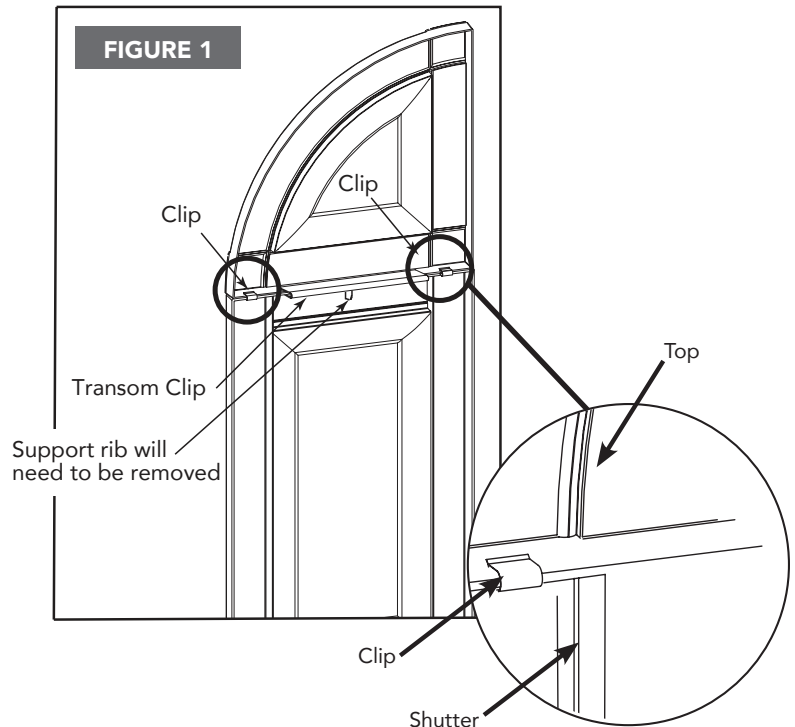

### STEP 2

Drill one (1) 1/4" hole as shown in Figure 2. For Transom tops, drill two (2) holes as shown in Figure 3.

### STEP 3

Fasten shutter to wall using instructions supplied with shutter. To prevent shutter from dimpling, do not over tighten.

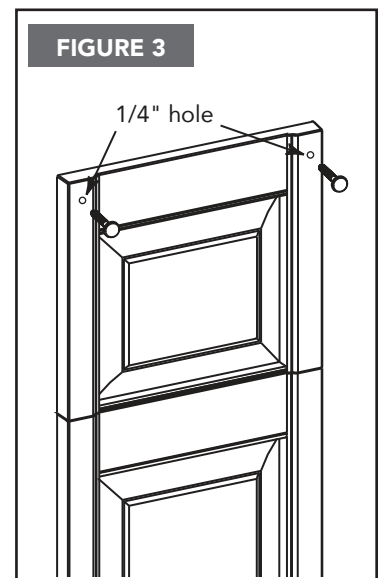
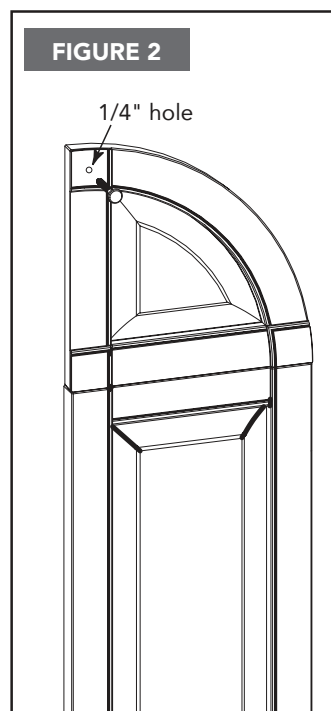

## SHUTTER HARDWARE

### REQUIRED FOR INSTALLATION:

Electric drill, Phillips screwdriver, 1/8" drill bit.

Kit contains (4) hinges, (2) S-hooks, (10) screws.

### STEP 1

Determine where hinges and S-hook will be installed. Hinges are typically installed near ends of shutters. S-hooks are installed on the bottom outer corner. See Figure 1.

**Note:** If placing hinges over fasteners, be sure pilot holes don't interfere with the fasteners.

### STEP 2

Using the marks on front of hinges as guides, drill pilot holes through the hinge and shutter using a 1/8" drill bit. The back of the S-hook has a fin, the screw will be placed here. After the position of the S-hook is determined, drill through the fin and into the bottom of the shutter using a 1/8" drill bit.

### STEP 3

Securely attach hardware using screws provided.

### NOTE:

If screw head coating is scratched during installation, touch-up with satin black paint.



S-Hook



Hinge

FIGURE 1

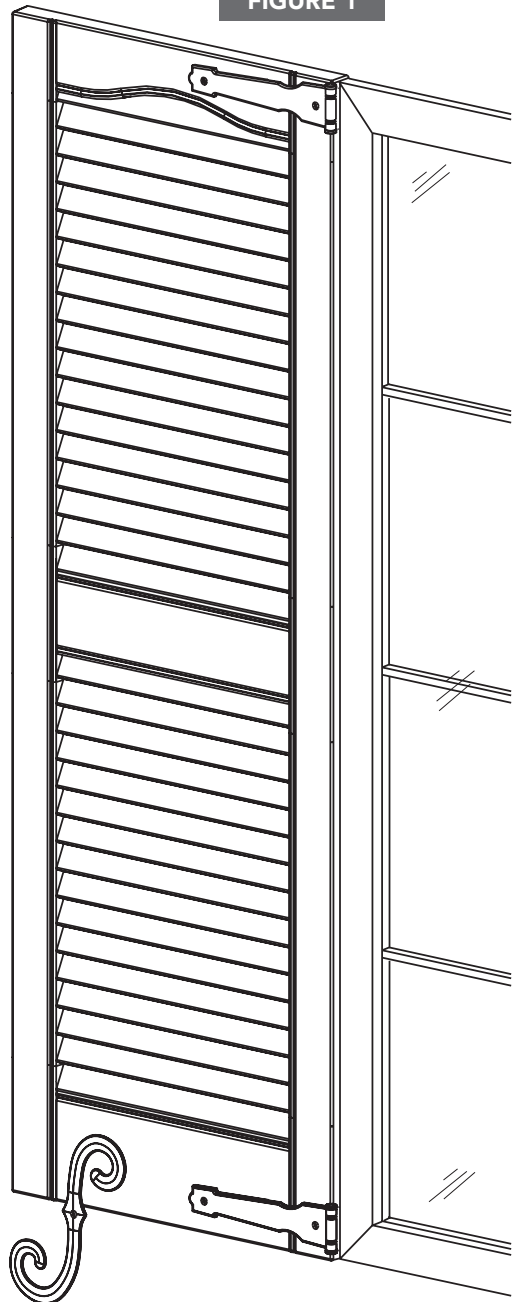



## FERRULE

### FOR USE ON A VARIETY OF SURFACES INCLUDING:

Wood, aluminum, vinyl, hardboard, brick, masonry and stone.

### REQUIRED FOR INSTALLATION:

Electric drill, 1/4" drill bit, 11/64" drill bit, hammer, Shutter-Loks® or screws and ferrule.

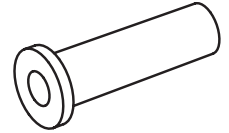

### STEP 1

Place shutter next to window, mark desired location against the wall or window.

### STEP 2

With shutter in location against the wall, drill through shutter into the wall to depth of 3-1/4". In brick, the hole diameter should be no greater than 1/4", and drilled into mortar joints. Do not attach shutter at this time. See Figure 1.

### STEP 3

Place ferrule behind shutter and line up with the holes drilled for the Shutter-Loks or screws. Trim ferrule to properly fit gap between back of shutter and wall to which it is being attached. Ferrules may not all be same length. Shutter-Loks used in masonry must penetrate into the wall to a depth of at least 7/8".

**Note:** If using screws, drill a hole 11/64". Follow shutter installation instructions based on height.

### STEP 4

Ensure ferrule is trimmed to desired length and shutter is parallel to wall. Insert Shutter-Lok or screw into the hole in the shutter and through ferrule into the wall. Tap Shutter-Lok gently with a hammer or drive in a screw to secure the shutter to the cladding. To prevent shutter from dimpling, do not over tighten.

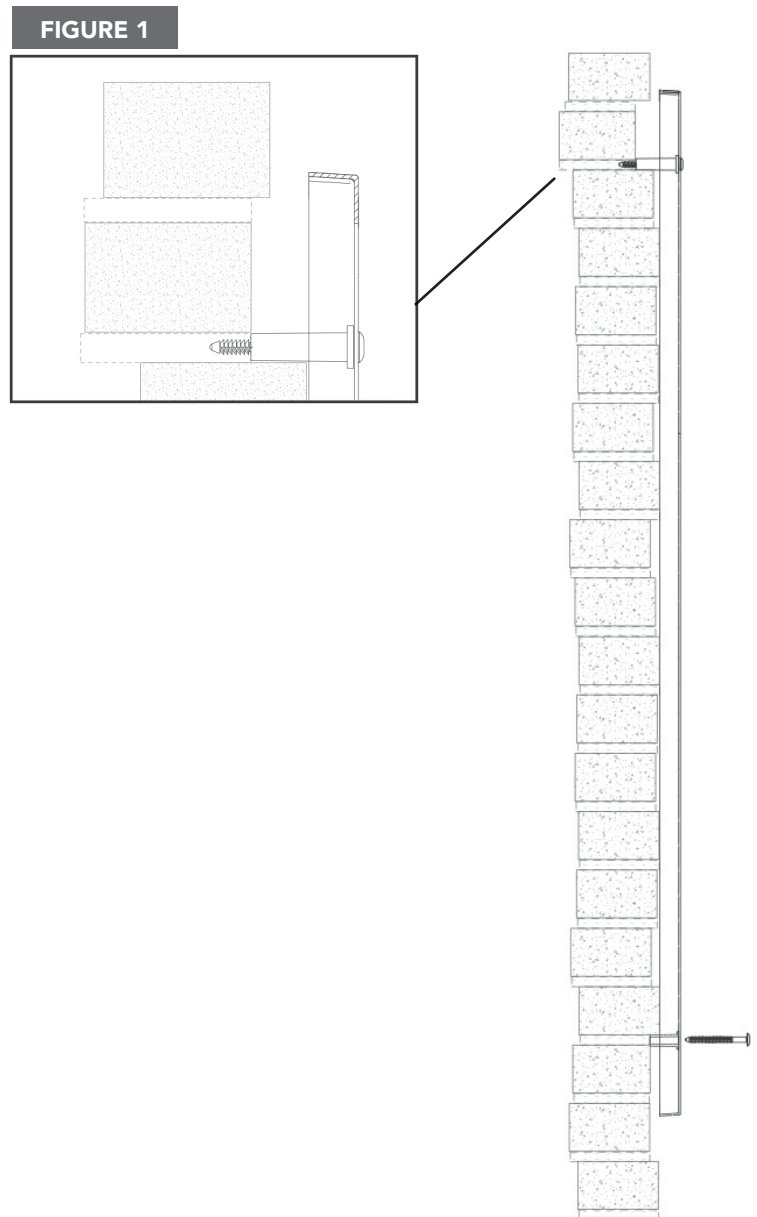



## SHUTTER CLIP

### REQUIRED FOR INSTALLATION:

Screwdriver, electric drill, level and pencil, (4) shutter clips for shutters up to 43" and (6) shutter clips for shutters 44" or greater. Also needed are (9) No. 10 or equivalent (M5 metric) screws. Other fasteners may be needed for specific surfaces (not included).

### STEP 1

Push a shutter clip onto the ribs at each corner of the shutter. The mounting tab should extend beyond the shutter. See Figure 2. Shutter clips will be removed later, so **DO NOT** fasten shutter clips completely onto the shutter at this time.

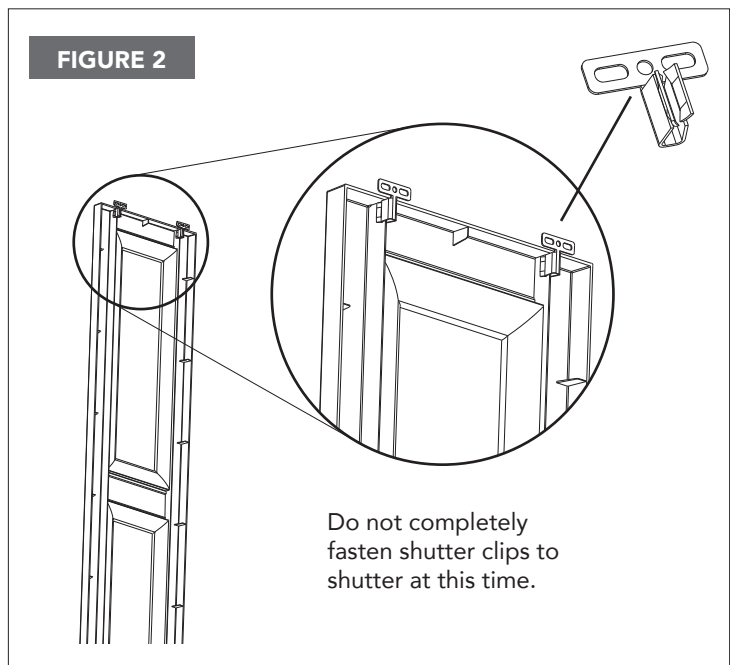
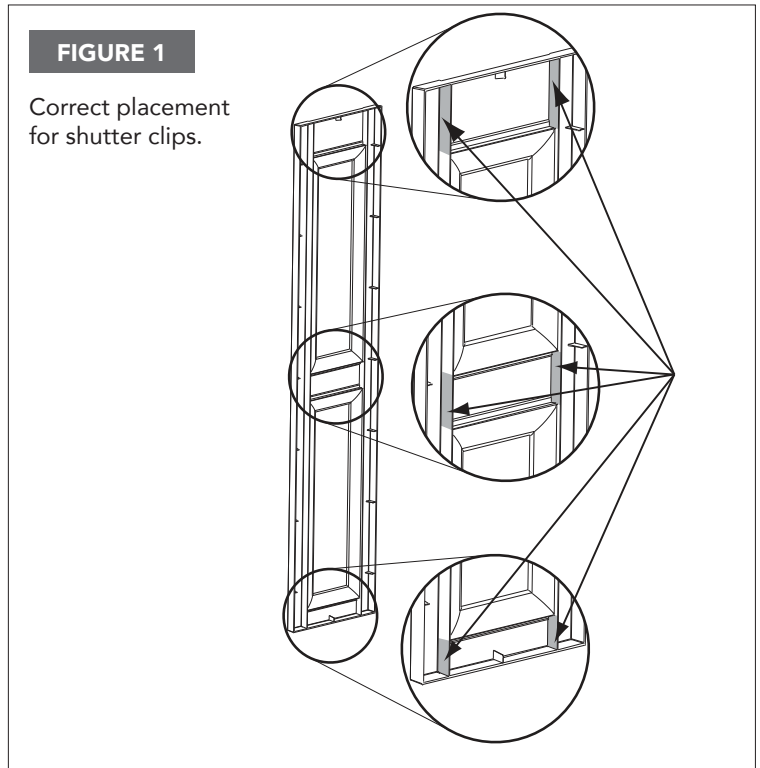

## SHUTTER CLIP, CONTINUED

### STEP 2

Hold the shutter where you want it to be attached on the mounting surface. Mark the center hole of each shutter clip in each clip. Draw lines vertically between top and bottom marks. After completing this step, remove shutter clips from shutter. See Figure 3.

### STEP 3

Place the front of the shutter against the mounting surface and align it next to where it will be installed. On the vertical lines drawn in Step 2, sketch marks corresponding to the mounting areas of the shutter. See Figure 3.

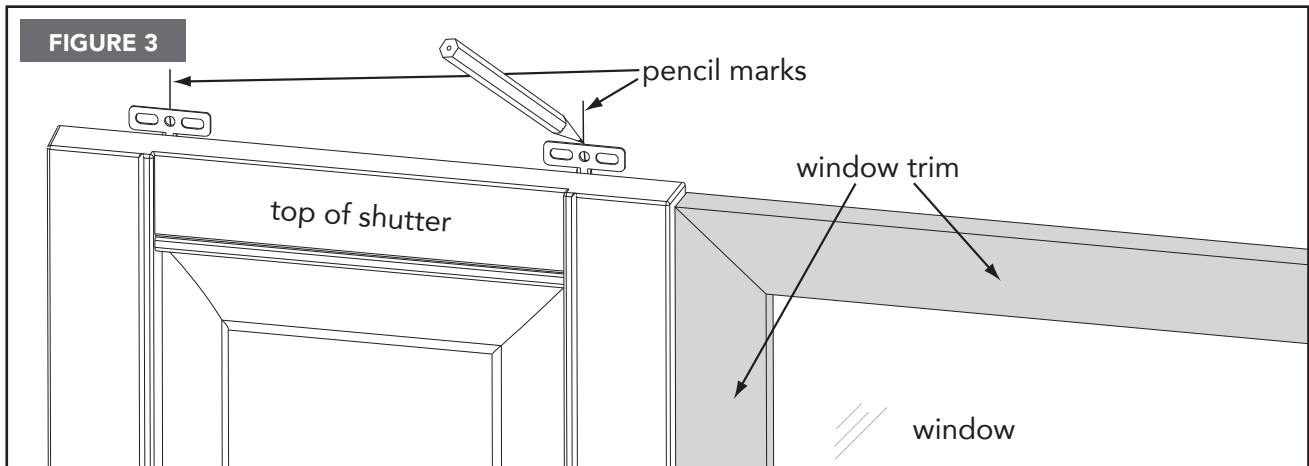

### STEP 4

Read complete instructions for Step 4 and examine Figure 4 before installing shutter clips to mounting surface. Fasten shutter clips centered on the vertical line and between the sketch marks drawn in Step 3. Use one (1) screw next to the window, and two (2) screws in the shutter clips away from the window. See Figure 4. Shutter Clips should be free to move with changes in temperature. Mounting bracket on shutter clip should be placed in upright position. Special mounting procedures or techniques may be required on different mounting surfaces.

### STEP 5

Once the shutter clips are positioned and secured to the mounting surface, attach shutter by placing shutter over shutter clips and pressing the shutter ribs on to each shutter clip. Press shutter firmly against mounting surface, making sure all six (6) clips are engaged.

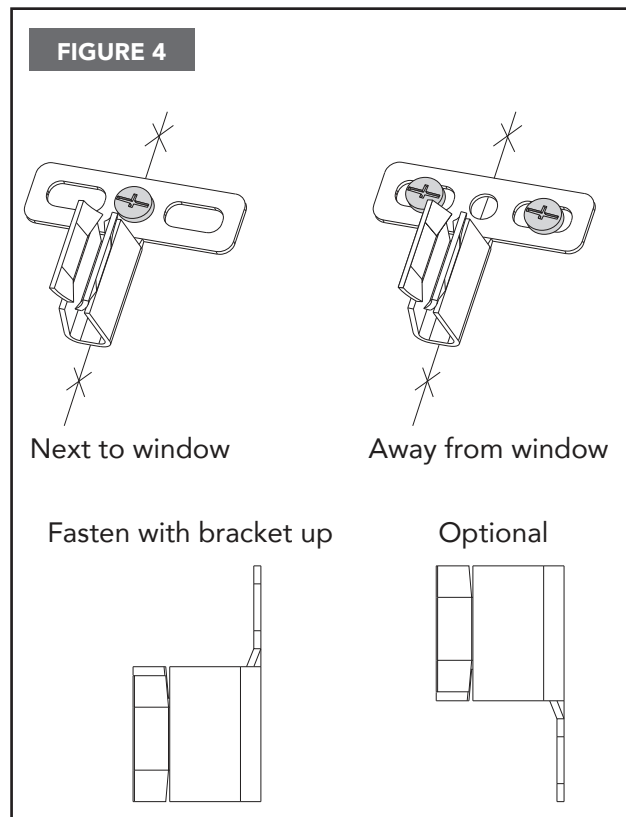



## TECHNICAL BULLETIN

### FRAMED SHUTTER INSTALLATION

*Applies to Louver, Panel, Board-N-Batten™ Shutters*

Maintain a minimum clearance of 1/4" along both sides and 3/8" at the top and bottom of the shutter to allow for movement.

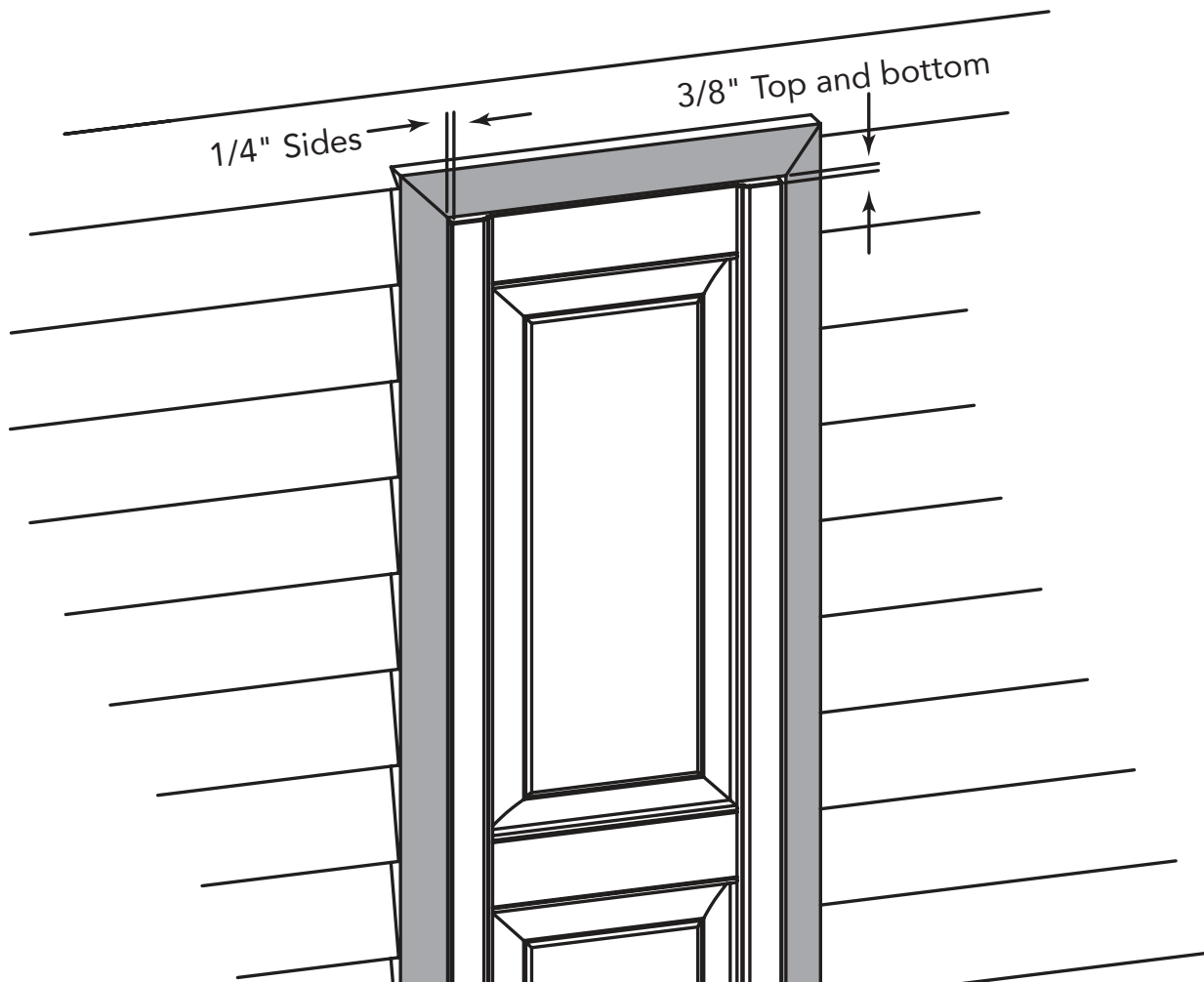

## SCALLOPED & SQUARE EXTERIOR DENTIL

Your home's style will determine which of the three (3) exterior dentil installation approaches are best. Installation always proceeds left to right. Installation approaches will also vary based on temperature. See table below.

### BOX CONTAINS:

(8) pieces of dentil in original or scalloped style, (24) screw covers and (24) screws.

### REQUIRED FOR INSTALLATION:

Electric drill and saw.

Installation Temperature—Spacing	
85° or greater	1/8"
40° - 84°	3/16"
40° or below	1/4"

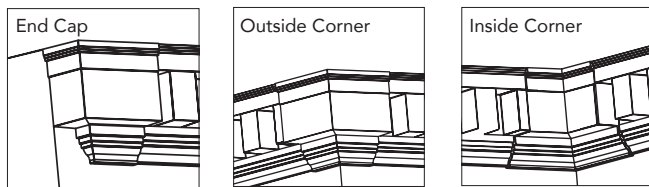

### STEP 1

The starting point will depend on which corner is used. Step 1A should be used when starting on an end cap or inside corner. Use Step 1B when starting on an outside corner.

#### STEP 1A

An end cap is used when exterior dentil will be terminated. An inside corner is used when the exterior dentil is continued into a 90° corner. Starting at the point where the dentil will be terminated or carried to an inside corner, measure back 3", placing a mark on the wall. See Figure 1. Place exterior dentil at this mark and secure it in place by screwing into the screw pockets in the dentil. See Figure A. The dentil must have room to expand and contract with temperature changes. Be careful not to screw the dentil in too tightly.

#### STEP 1B

An outside corner is used when exterior dentil is continued around a 90° corner. Place the exterior dentil at a position flush with the corner of house. Secure dentil in place by screwing into the screw pockets in the dentil. Because the dentil must expand and contract with temperature changes, be careful not to screw the dentil in too tightly. See Figure 2.

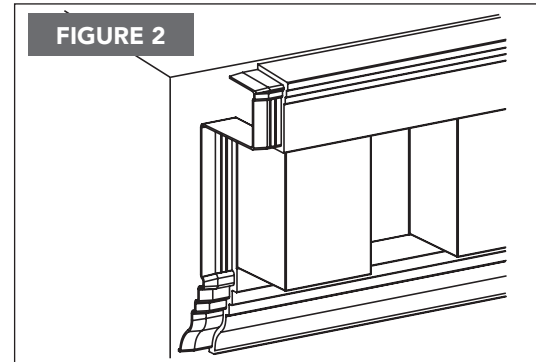
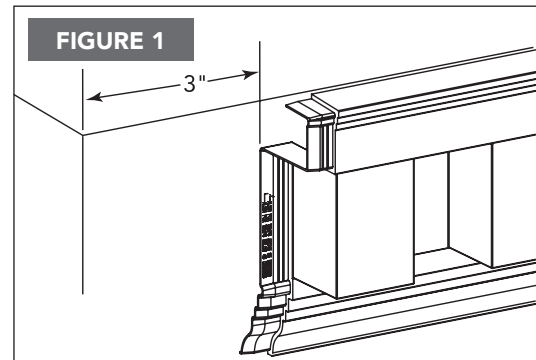
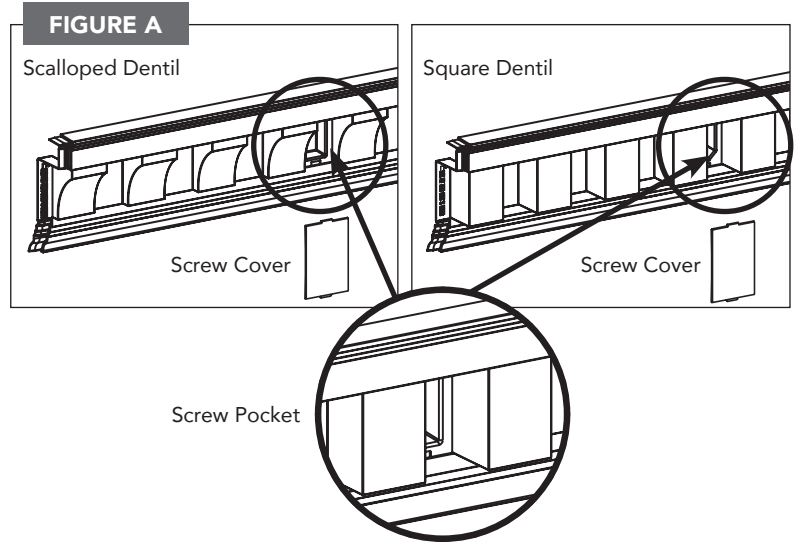

# SCALLOPED & SQUARE EXTERIOR DENTIL, CONTINUED

**STEP 2**

Once you've established a starting place, slide the second piece of dentil in place. Two (2) alignment lines can be found on the dentil's left end. See Figure 3A.

Continue installation by sliding dentil from left to right, leaving the appropriate space in between. Secure by screwing into the screw pocket of the dentil. See Figure 3B.

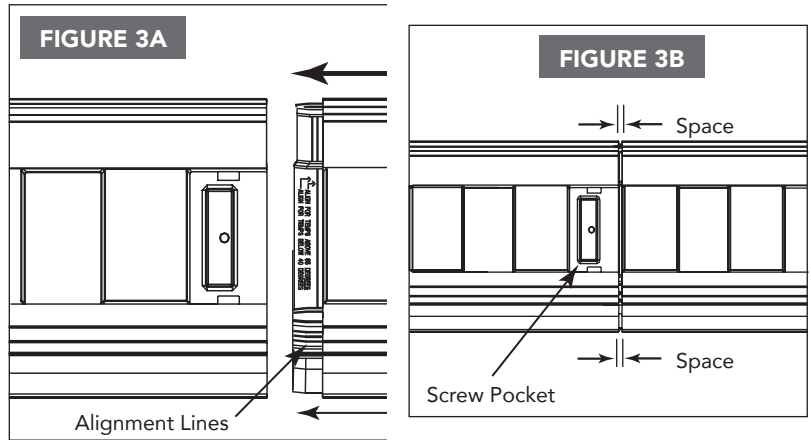

**STEP 3**

As each section of dentil is secured in place, install screw covers. First, place the hook into the bottom of the dentil screw pocket. Next, push the flat tab into the top of screw pocket until it is securely locked into place. See Figure 4A and 4B.

**STEP 4**

At end of each wall, it may be necessary to cut the dentil. When cutting exterior dentil, measure and cut from the right side. When terminating with an end cap, make sure the dentil ends 3" from the end of the wall. See Figure 5.

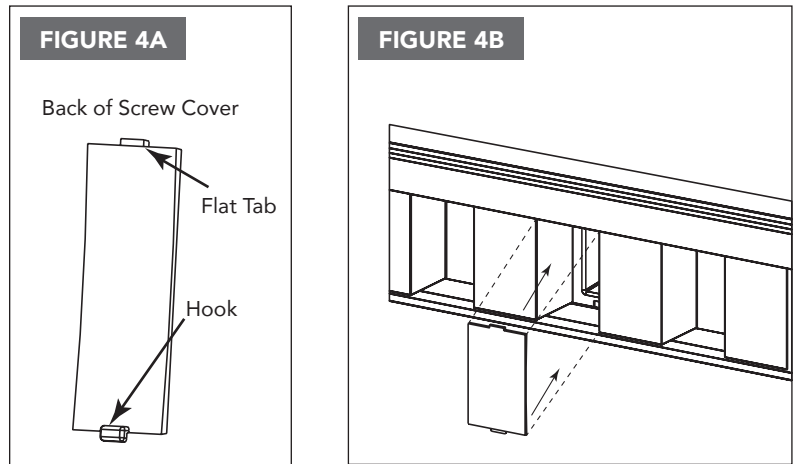

**STEP 5**

When using a cut segment of dentil to continue an inside or outside corner, you may have to trim that segment. See Figure 6. Cutting the dentil at this 1/2" dimension will eliminate need for later modifications of the corner.

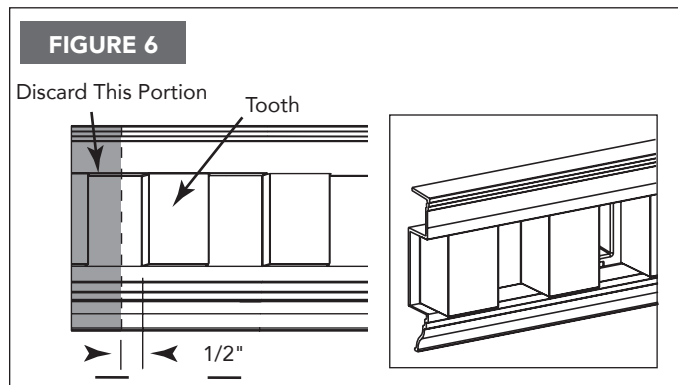
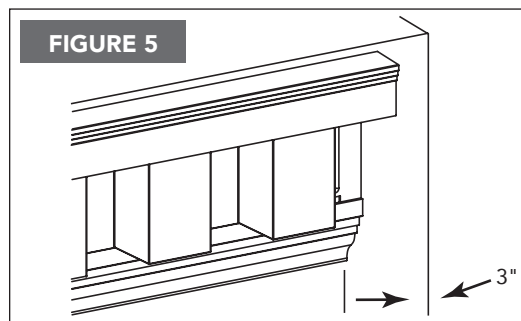

## DENTIL CORNER

### BOX CONTAINS:

(1) Right end cap or (1) left end cap, (4) rivets.

### CORNER BOX CONTAINS:

(1) Inside corner or (1) outside corner, (4) rivets.

### REQUIRED FOR INSTALLATION:

Electric drill, 1/8" drill bit, rivet gun and utility knife.

### SCALLOPED EXTERIOR DENTIL

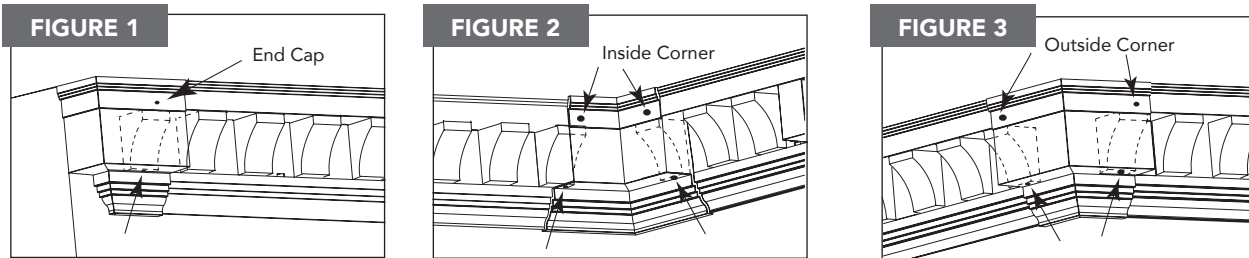

Exterior dentil corners are designed to complete installation of the exterior dentil square or scalloped trim.

**Three (3) terminations are available:** end cap, inside corner and outside corner. See Figures 1–3.

### STEP 1

Drill 1/8" hole on face of end cap and use rivet gun to attach rivets to dentil trim. When securing bottom surface of end cap to exterior dentil, rivets must enter a tooth.

See Figures 1–3 to identify placement of rivets on three different end caps.

**Note:** When installing end caps, there may be interference between cap and dentil tooth. See Figures 1–3.

### STEP 2

If interference takes place on an inside corner, remove the wall on the end cap by using a knife to score and cut from the back side. The wall on the outside corner can be removed by snapping it off or using a knife as described above. See Figures 2A through 2C.

### NOTE:

If necessary, end caps can be created by cutting outside corners at the scribe lines. See Figure 3.

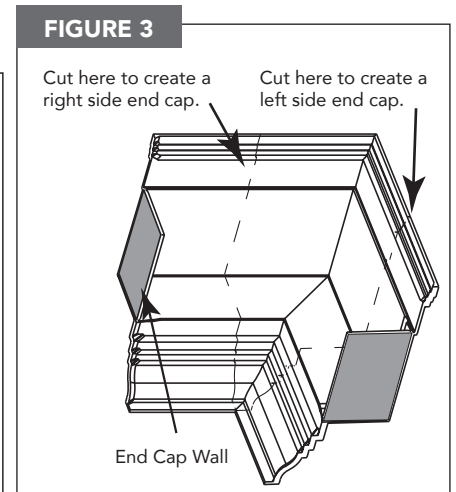
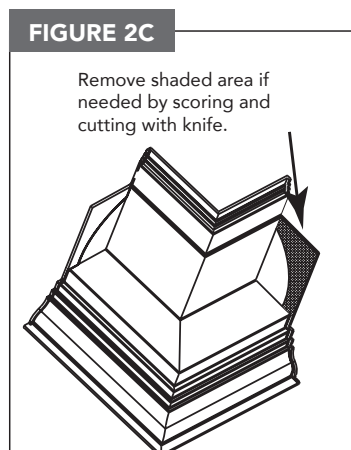
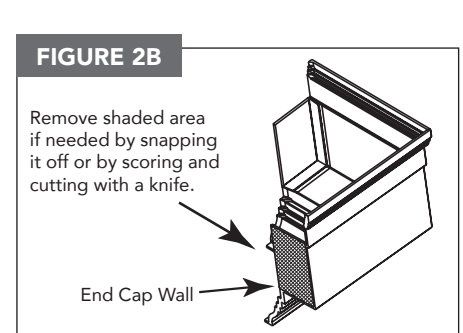
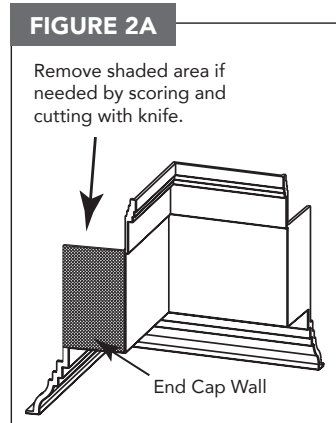

## 6" & 9" WINDOW HEADERS WITH KEYSTONE

### INSTALLATION & CUTTING INSTRUCTIONS FOR 6" AND 9" HEADERS WITH KEYSTONE:

Combines a basic header installation with keystone and cutting.

#### HEADER BOX INCLUDES:

(1) Flat panel or dentil header, (1) header base, (3) fastener packs.

#### REQUIRED FOR INSTALLATION:

Electric drill, saw, measuring tape, 1/4" drill bit and utility knife.

#### STEP 1

Measure width of window across longest measurement to create Dim (Dimension) A. Draw a horizontal line 1/8" above the window trim, to be used to ensure appropriate space between window header and window trim. See Figure 1. If header is too long for window, proceed to Step 2A. If not, proceed to Step 4.

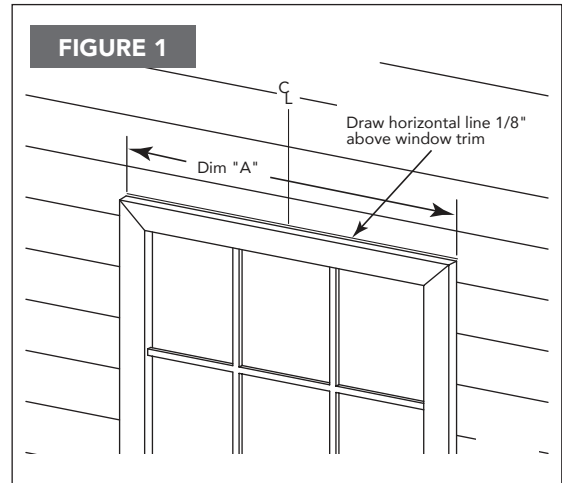

#### STEP 2A

If window header doesn't match the precise size of your window, you will have to cut the window header. After assembling the window header and window header base, mark the center on the assembly. See Figure 2A.

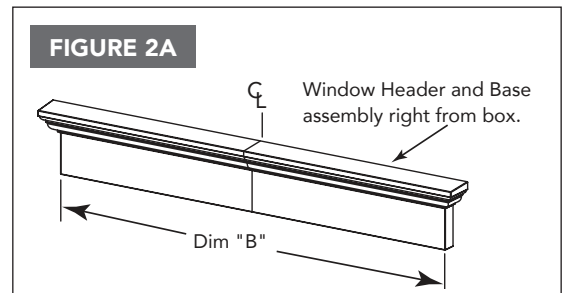

#### STEP 2B

Subtract Dim. A from Dim B and divide the measurement in half. The result will be Dim. C. See Figure 2B.

**FIGURE 2B**

$$\frac{\text{Dim. "B"} - \text{Dim. "A"}}{2} = \text{Dim. "C"}$$

#### STEP 2C

Transfer Dim. C to the window header assembly twice, once on each side of the centerline. See Figure 2C.

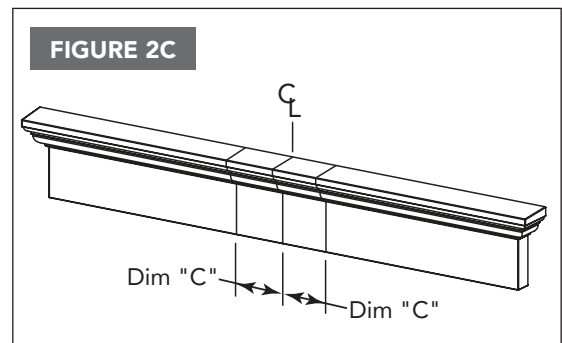

#### STEP 3

Cut window header and window header base.



## 6" & 9" WINDOW HEADER WITH KEYSTONE, CONTINUED

### STEP 4

After cutting window header to correct length, disengage the locking tabs and remove the window header from the window header base. Release locks by starting at the open end of the cut header base. Continue these steps to the end of the cut window header assembly. See Figure 3.

### STEP 5

Using the elongated slots in the header base, secure the base to the cladding using the screws provided. An alternative method would be to use Shutter-Loks®. Raised portions of the header base featuring the round holes receive the Shutter-Loks. Attach Shutter-Loks by drilling 1/4" holes into the wall. To allow for expansion and contraction, do not fasten screws or Shutter-Loks too tightly. See Figure 4A.

The window header may rock on the high point of the siding. To overcome this issue, insert screws or Shutter-Loks into wall evenly. See Figures 4A and 4B.

### STEP 6

Once the window header base is secured to wall, attach the window header by snapping into place. See Figure 5.

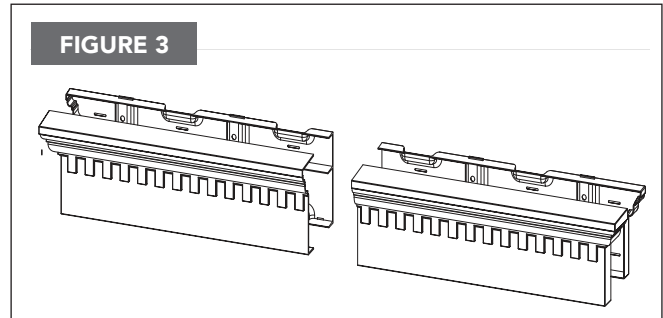
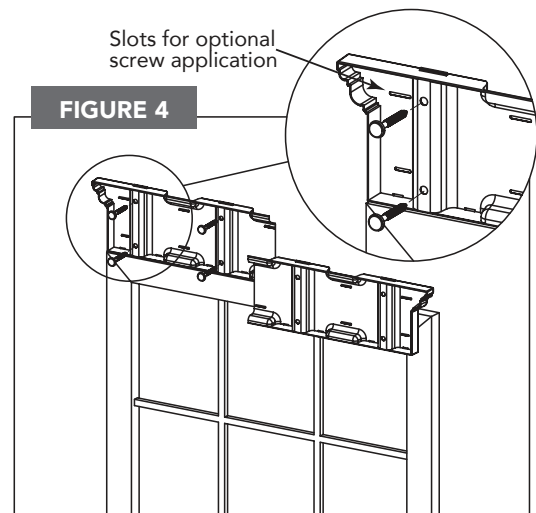
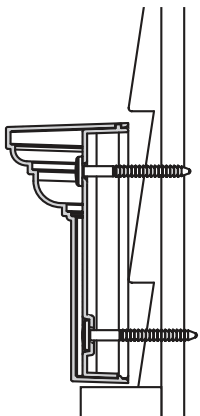
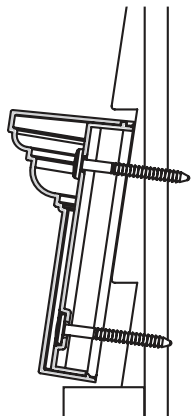
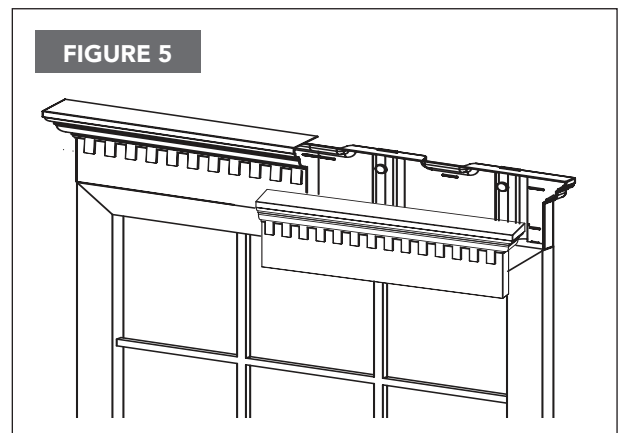
**FIGURE 3****FIGURE 4****FIGURE 4A****CORRECT****FIGURE 4B****INCORRECT****FIGURE 5**

## 6" & 9" WINDOW HEADER WITH KEYSTONE, CONTINUED

### STEP 7

Center keystone base over window header assembly. To aid installation, use the tab at the bottom of the keystone base, ensuring the bottom of the tab and bottom of the window header are flush. Screw keystone base into place using enclosed screws. Note that Shutter-Loks can be used to secure the keystone base to the window header. Drill two (2) 1/4" holes through the window header and tray to accept Shutter-Loks. See Figure 6.

### STEP 8

If the dentil teeth land on the sides of the keystone, it will not properly snap in place unless trimmed. Trim thinned areas on keystone cover with utility knife as shown. See Figure 7.

### STEP 9

Snap keystone over keystone base, making sure the locking tabs engage. See Figure 8.

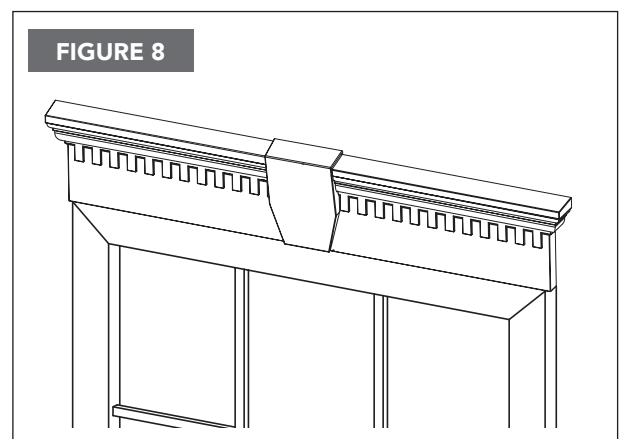
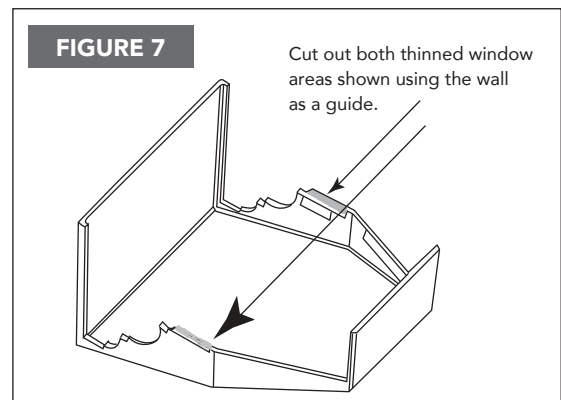
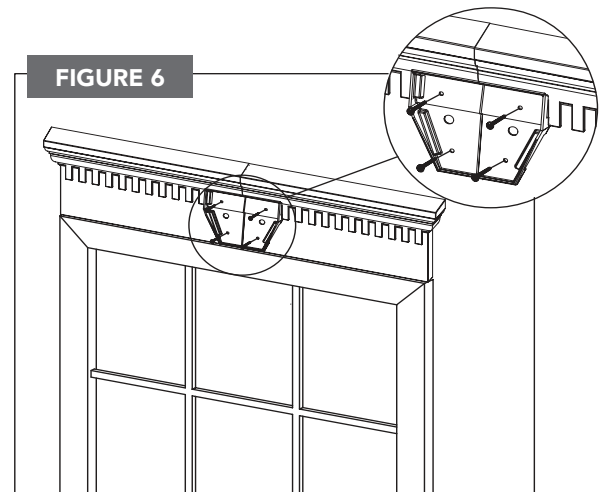

## 6" & 9" J-CANNEL BACK PLATE FOR WINDOW HEADERS

### BOX CONTAINS:

(1) J-channel back plate, butyl tape and screws.

### REQUIRED FOR INSTALLATION:

Electric drill, saw, 1/4" drill bit and tape measure.

### STEP 1

Measure length of header to be installed on base. Record this dimension as Dim. A to determine the amount to be removed. See Figure 1. If the header and back plate is cut to precise length, skip to Step 3. If you need to cut the header to length, refer to Keystone & Cutting Instructions included with header.

If backplate does not need to be cut, proceed to Step 3. If back plate needs to be cut to length, refer to 2A or 2B of 6"/9" Window Header Installation guide. Use same process as cutting a window header. Then continue with Step 2.

### STEP 2

Flip back plate over, exposing the back side. Apply 12" length of foil-backed butyl tape provided with header base. Work from top of mount to bottom, keeping tape tight to inside of part. This ensures a watertight installation of the siding mount.

**Note:** If siding mount ribs are too close to permit the application of the full tape width, trim ribs with utility knife. See Figure 2.

### STEP 3

Draw horizontal level line 1/8" above window trim to locate bottom of the mount. In addition, draw a vertical line at center of window for alignment. See Figure 3.

### STEP 4

If the back plate aligns with the J-channel, remove the tab on the end of the mount. See Figure 4. Use knife slots on the inside of the tab as a guide. If the back plate exceeds the window flange or J-channel, the tab can be left in place to divert water.

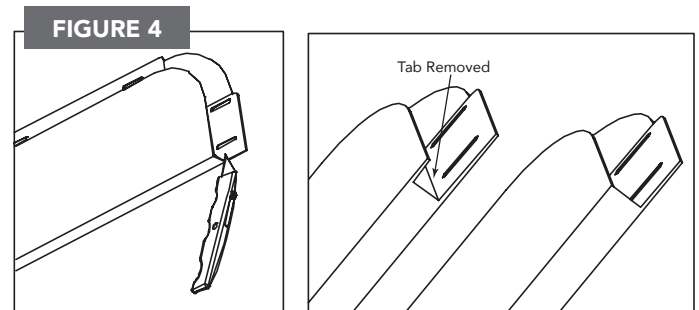
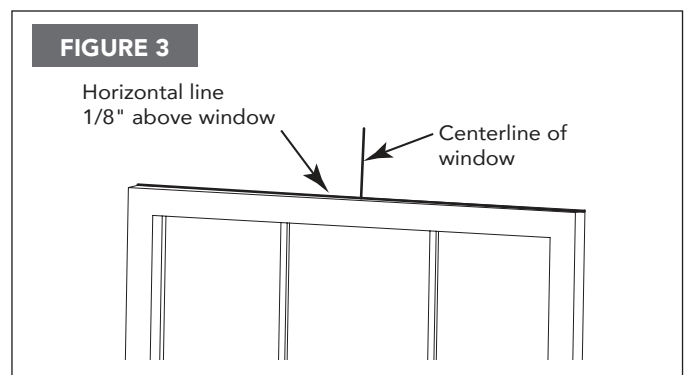
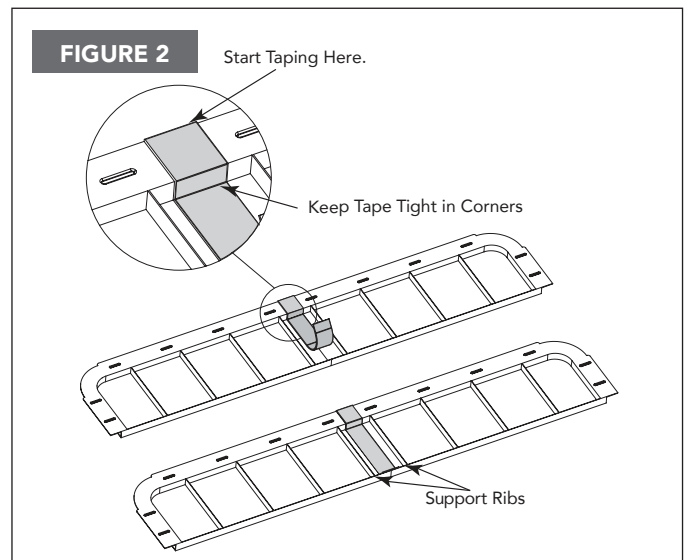
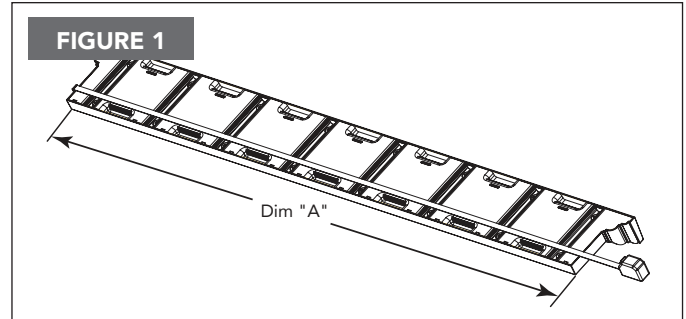

## 6" & 9" J-CANNEL BACK PLATE FOR WINDOW HEADERS, CONT.

### STEP 5

Secure back plate to sheathing. Align back plate with centerline and horizontal lines drawn in Step 3. Nail in the center of nailing slots to allow for expansion and contraction. See Figure 5.

### STEP 6

Continue securing back plate above window. Cut top ends of J-channel to create a tab for tucking under header mount.

### STEP 7

Once J-channel is secure, use two (2) 2" x 2" included butyl tape strips to cover seams between nailing flanges of the J-channel and the header mount on either side of opening. See Figure 6.

### STEP 8

Install siding around opening.

### STEP 9

Attach window header to back plate. See 6"/9" Window Header Guide for complete instructions.

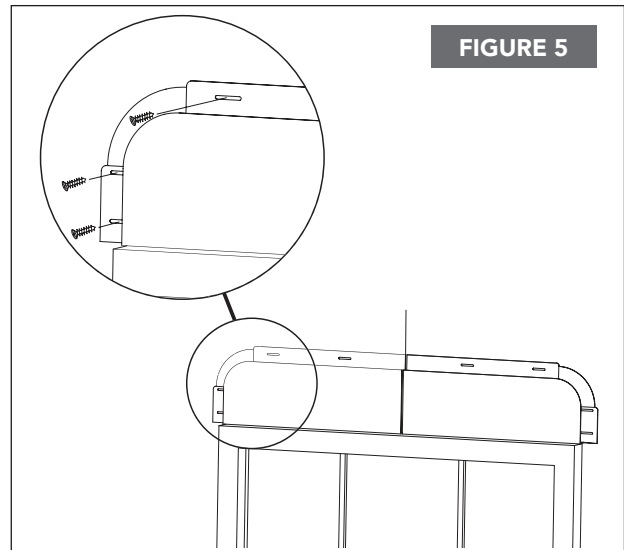
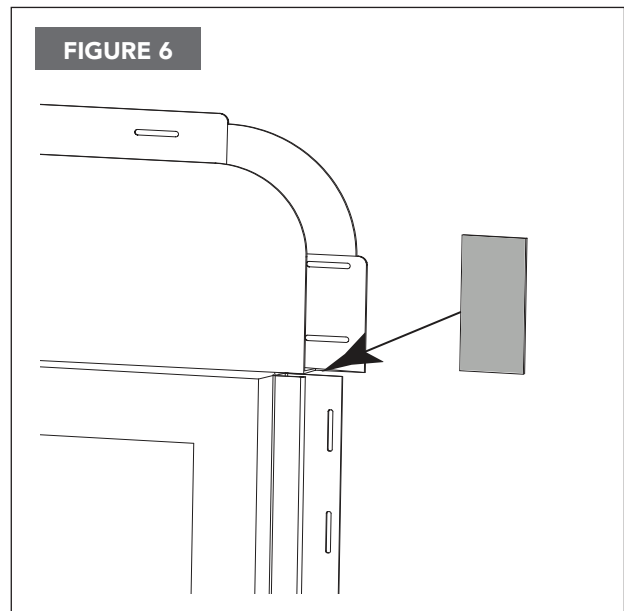
**FIGURE 5****FIGURE 6**

## PILASTER WITH J-CHANNEL BACK PLATE

### THE PILASTER CONTAINS:

(2) Transition tops (one left, one right), (2) pilasters, (2) pilaster bases, (2) bottom corners (one left, one right), (2) bottom corner bases, (2) 24 pk. screws, (3) 12 pk. Shutter-Loks® and (4) transition clips.

Optional components for installation not included with the pilaster are (1) header back plate (6" or 9"), (2) 6" x 90" pack plates for pilasters, (1) 6" or 9" header, (1) 6" keystone, (1) 6" or 9" keystone.

### REQUIRED FOR INSTALLATION:

Electric drill, 1/4" drill bit, saw, measuring tape and square.

### NOTE:

The illustrations contained in these instructions use a 9" header and base for examples. A 6" header and base can be used just as easily. Siding has been removed from illustrations for visual clarity.

If not using J-channel back plate, follow installation instructions disregarding back plate references.

### STEP 1

Measure door height, including any brick mold or trim around door. Record this as Dim. A. See Figure 1.

### STEP 2

Cut bottom radius of J-channel back plate off. Using Dim. A, subtract 1/4" from measurement and cut back plate to length. Repeat for other side. See Figure 1A.

### STEP 3

(If not using back plate, proceed to Step 4.) Screw pilaster mounts to sheathing 1/8" away from sides of door, and 1/4" away from the bottom of door. This should leave top of mount flush with top of brick mold. Be sure not to over fasten, allowing for expansion and contraction.

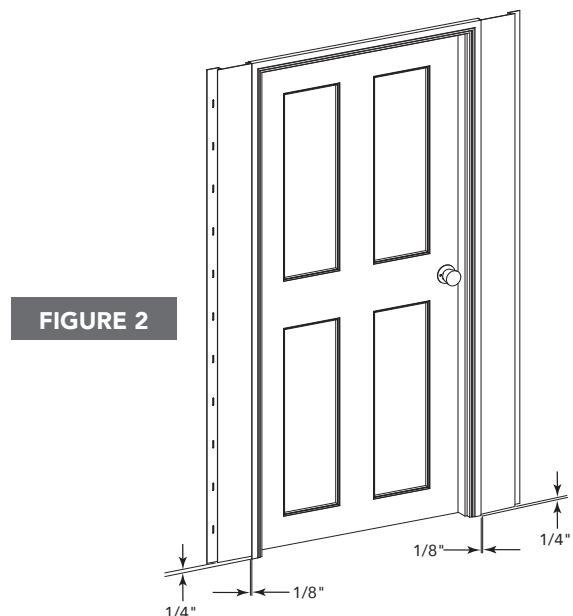
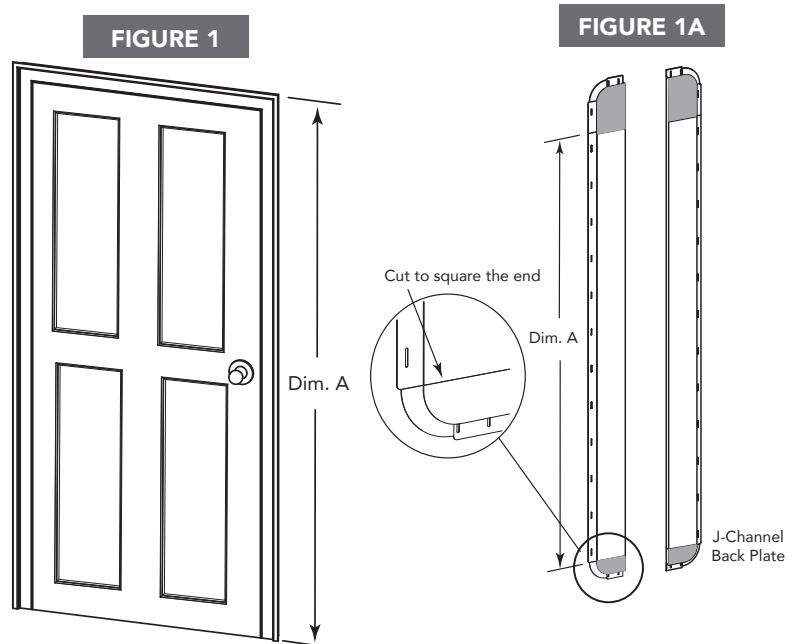

## PILASTER WITH J-CHANNEL BACK PLATE, CONTINUED

### STEP 4

Cut the pilaster assemblies to the correct length. Use the following formula: 96" (length of pilaster), minus Dim. A, minus 1/2", equals Dim. B.

Measure and cut Dim. B from top of both pilasters. See Figure 3. Before cutting, ensure pilasters are oriented in correct position, with the flat side of the pilaster against door. If Dim. B is greater than 12", cut the remaining material off the bottom of pilaster.

### STEP 5

Separate the pilasters from the pilaster base. Position the pilaster base on top of J-channel back plate or directly onto the cladding as shown in Figure 4. Place screw in the center hole of pilaster base. Do not substitute Shutter-Lok for screw.

### STEP 6

Place remaining screws in slots, or drill 1/4" holes into the wall to a depth of 3" to accept Shutter-Loks. Use Shutter-Loks only in the round holes molded in raised areas of pilaster base. For locations, see Figure 4. Complete this step for both sides of door. Screws should be centered in slot. To allow for expansion and contraction, fasteners should not be over tightened.

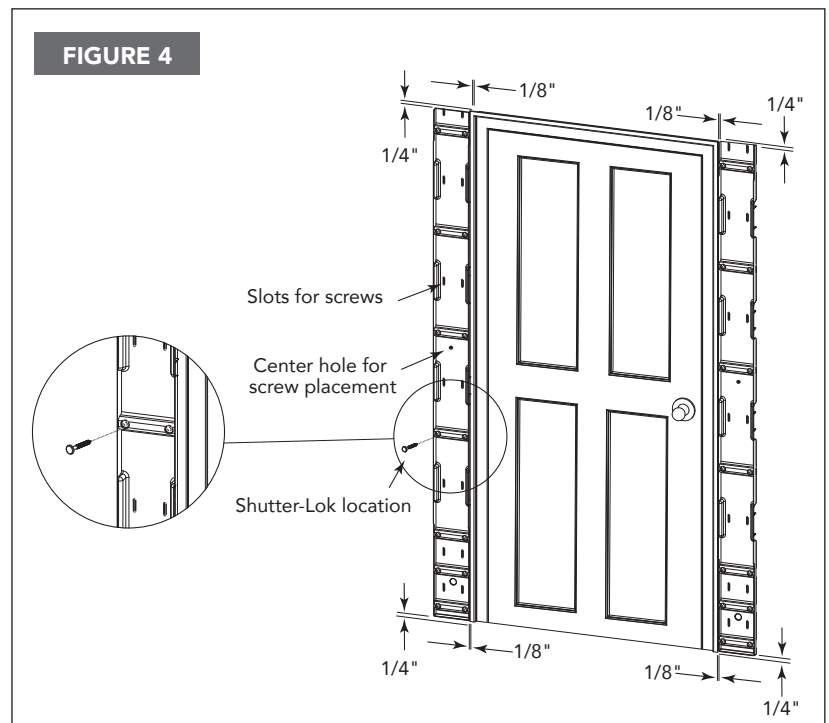
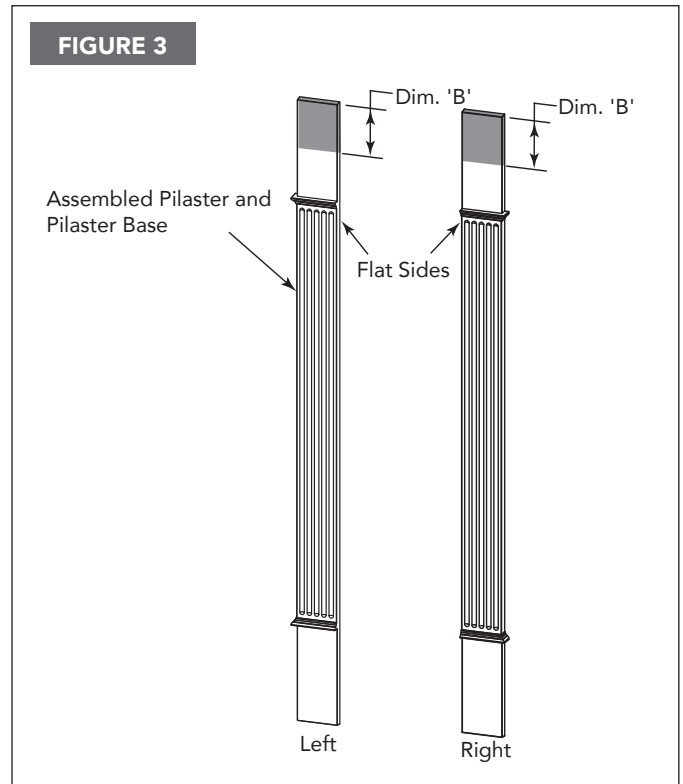

## PILASTER WITH J-CANNEL BACK PLATE, CONTINUED

### STEP 7

Snap pilasters over pilaster bases, making sure the pilaster locks are fully engaged.

### STEP 8

Mark center of door with vertical line. See Figure 5.

### STEP 9

**Note:** There are different methods for placing header on door. See Methods A and B.

If header included in purchased kit was pre-cut to length, skip to Step 17.

### STEP 10

Measure distance between outside edges of pilasters and record this as Dim. D. See Figure 5A.

### STEP 10A

If you seek an installed appearance like Method A, add 1-1/4" to Dim. D. This allows header to be flush with the transition top when it's installed.

### STEP 10B

If you seek an installed appearance like Method B, add the amount of overhang you prefer. Double the amount of overhang when adding because you want the overhang to extend on both sides of door.

### STEP 11

With header and header base assembled, mark center of assembly. Do this by measuring bottom of the header to the mounting surface of the base. See Figure 6.

### STEP 12

Subtract the dimension from Method A or Method B. Dim. D from Dim. F and divide the result in half. The result will be Dim. G. See Figure 7.

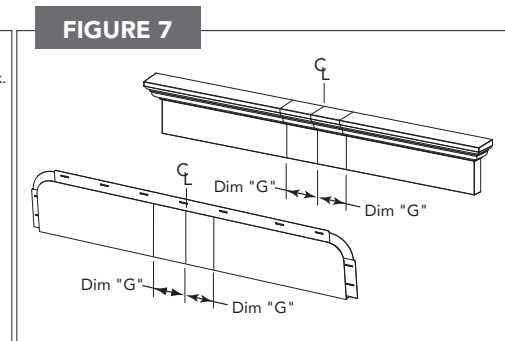
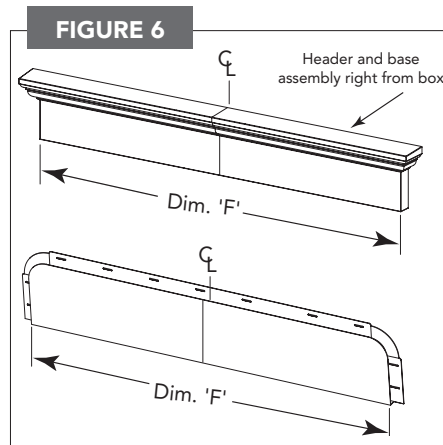
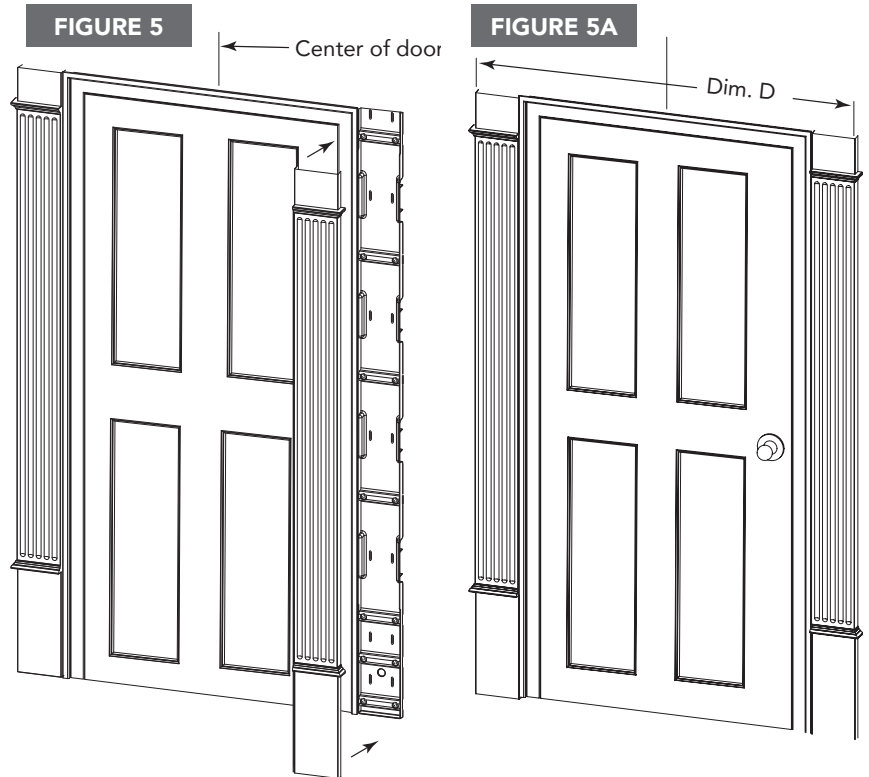
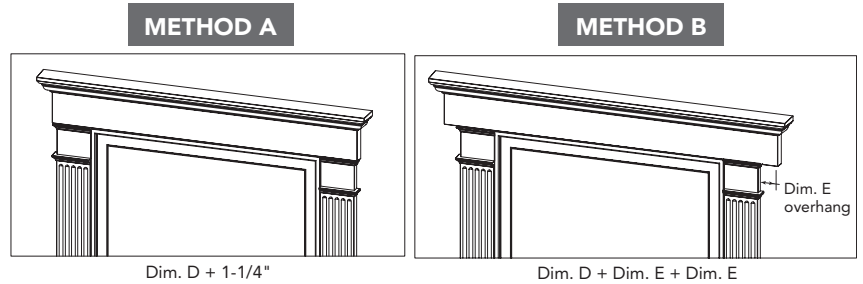



## PILASTER WITH J-CANNEL BACK PLATE, CONTINUED

### STEP 13

Transfer Dim. G to header assembly and to J-channel back plate. Dim. G will be transferred twice, once on each side of the centerline. See Figure 8.

### STEP 14

Cut header/base assembly and back plate assembly at lines created by Dim. G.

### STEP 15

Once you have cut components to correct length, disengage locking tabs and remove header from the header base. To release locks, start at open end of cut header assembly and pull the wall of header away from the header base. Continue this step until you reach the end of the cut header assembly. See Figure 9. If not using J-channel back plate, proceed to Step 18.

### STEP 16

Flip J-channel back plate over, exposing back side of mount. Apply the 12" length of foil-backed butyl tape supplied with header base. Start at top of mount, working all the way to bottom. Make sure tape fits tightly in inside corners of the part, ensuring a watertight installation of siding mount.

**Note:** If the ribs of siding mount are too close to allow application of the full width of tape, use a utility knife to trim from the corresponding ribs. See Figure 10.

FIGURE 8

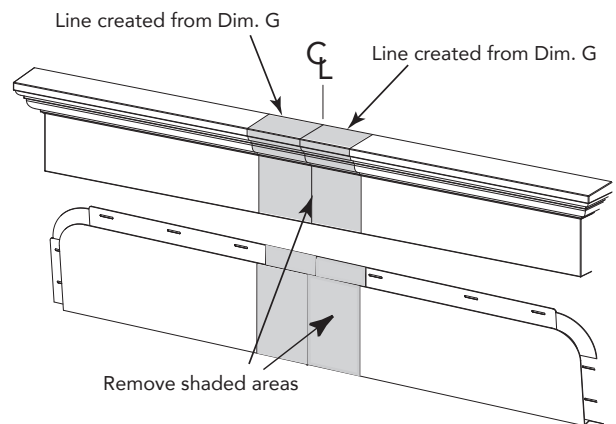

FIGURE 9

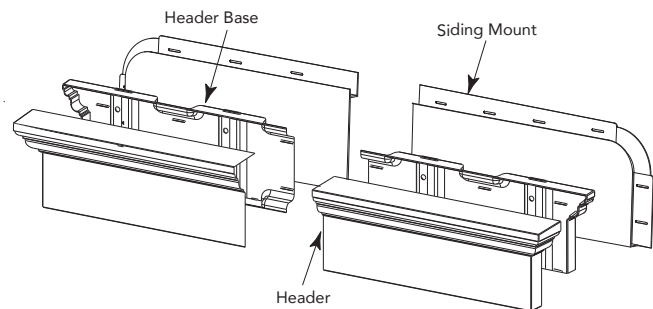
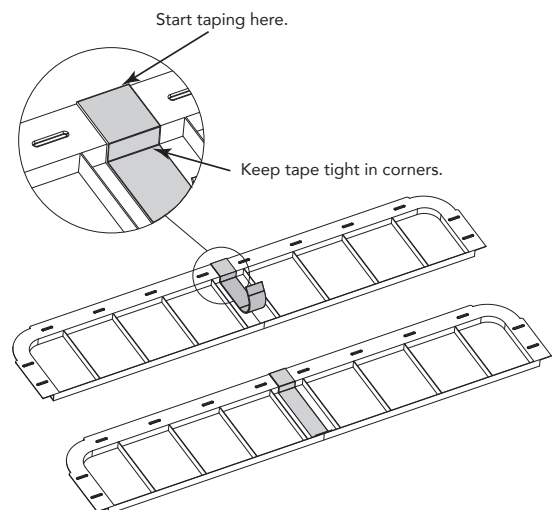

FIGURE 10



## PILASTER WITH J-CANNEL BACK PLATE, CONTINUED

### STEP 17

Align centerline of back plate with centerline of door. Leave a gap of approximately 1/8" between bottom of back plate and top of door, providing the header with clearance when snapped into place. When mount is in proper location, attach to the sheathing with screws provided. See Figure 11.

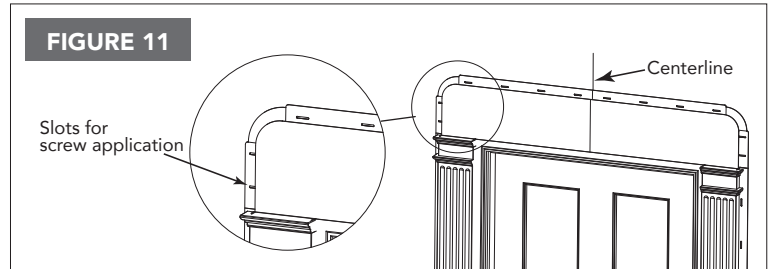

### STEP 18

Align centerline of header base with centerline of door. Align bottom of header base with bottom edge of J-channel siding or cladding, leaving 1/8" between the header base and the top of the door trim. A preferred method of attaching base to house is with Shutter-Loks supplied in the kit. To install Shutter-Loks, drill 1/4" holes in the wall to a depth of 3". Use Shutter-Loks only in the round holes molded into the raised areas of header base. Space the Shutter-Loks accordingly along the header base. See Figure 12. Another method involves use of screws. Use elongated slots in base, using the screws supplied in kit to attach base to house. To allow for expansion and contraction, avoid over tightening screws.

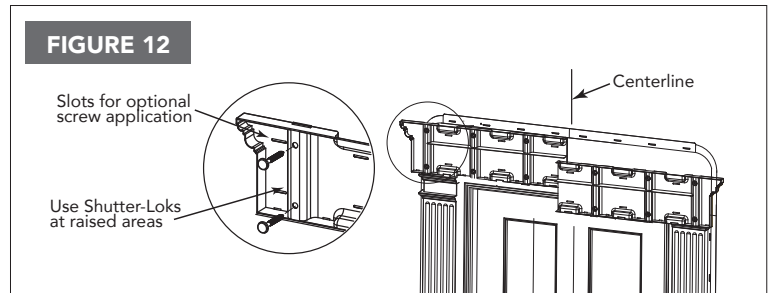
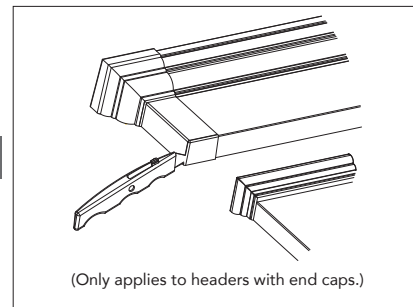
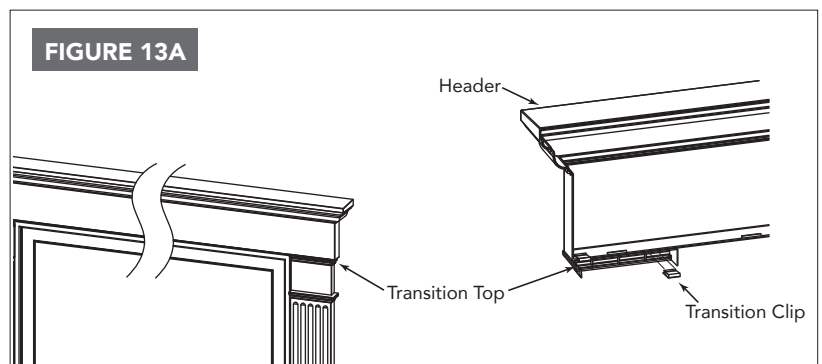

FIGURE 13



### STEP 19

Place transition top pieces on header in approximate location of pilasters. If header has optional welded-on end caps, trim the bottoms of end caps with a utility knife to ensure the transition top pieces are flush. See Figures 13 and 13A. Clip them to header using clips provided, using two clips per transition top.



### STEP 20

Snap header over header base. Transition top pieces may have to be repositioned to line up with pilasters.

### STEP 21

Center keystone base over header. Bottom of keystone base and bottom of header should be flush. Use the supplied screws to screw keystone base into place. See Figure 14.

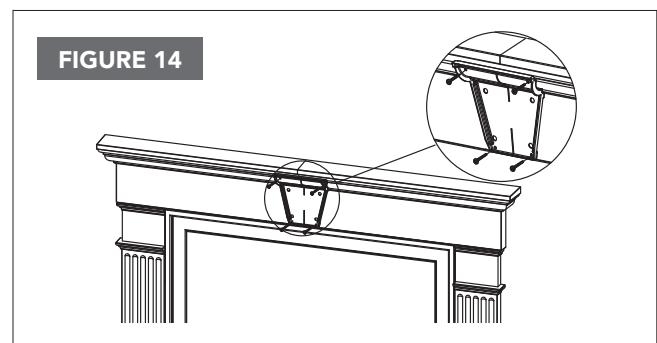

## PILASTER WITH J-CANNEL BACK PLATE, CONTINUED

### STEP 22

Snap keystone over keystone base, making sure lock tabs engage.

### STEP 23

Note directions on back of bottom corner base that show correct orientation for the left and right side of door. Line up bottom of bottom corner base with bottom of pilaster. Use the elongated screw slots to determine proper screw placement, secure corner base to pilaster.

### STEP 24

Once bottom corner base is secured in place, snap the bottom corner over the bottom corner base. Repeat step on other side of door. See Figure 16.

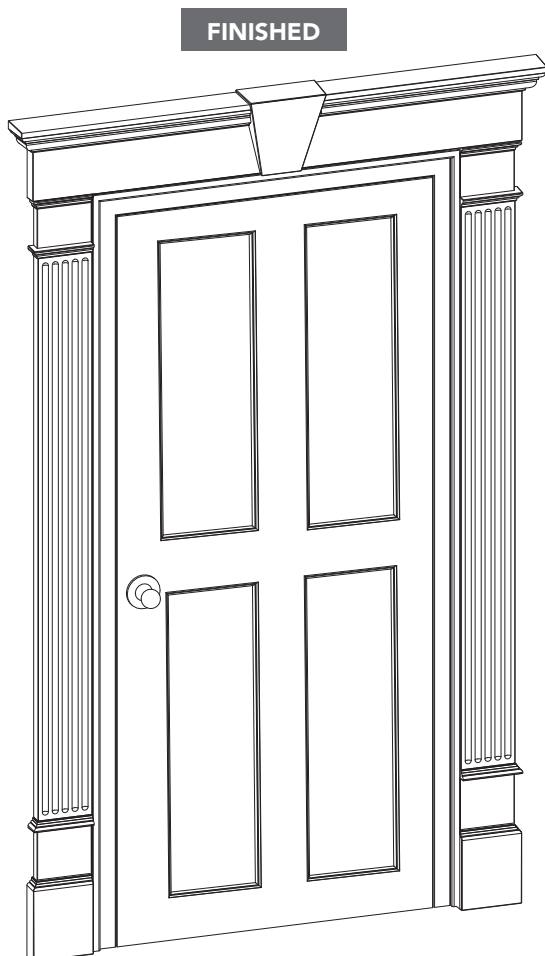

**FIGURE 15**

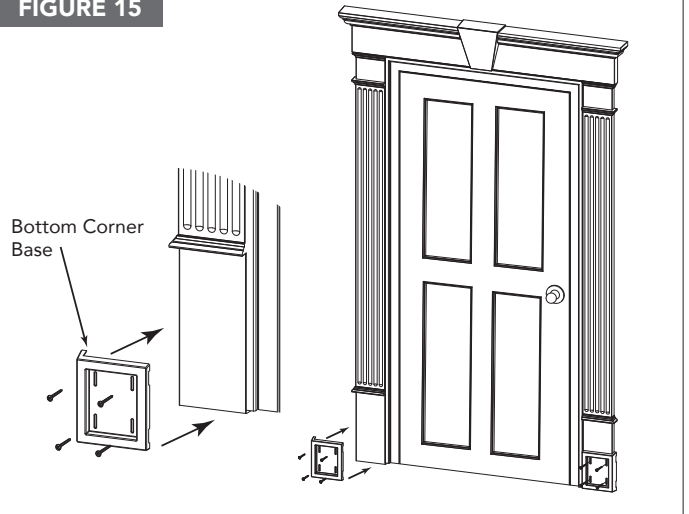

**FIGURE 16**

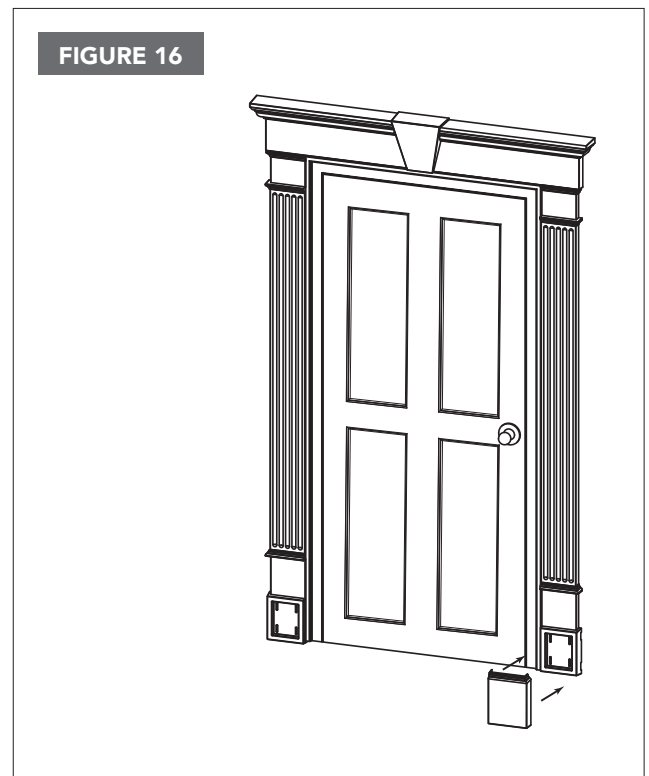







## BUILDERS EDGE INSTALLATION GUIDE

[BuildersEdge.com](http://BuildersEdge.com)

For more information contact our customer service department: 800.521.8486

Builders Edge | 29797 Beck Road | Wixom, MI 48393

**Westlake**  
Royal Building Products™  
[WestlakeRoyalBuildingProducts.com](http://WestlakeRoyalBuildingProducts.com)

SIDING & ACCESSORIES  
TRIM & MOULDINGS  
ROOFING  
STONE  
WINDOWS  
OUTDOOR LIVING

© 2022 Westlake Royal Building Products

BE30048341 2/22