



# INSTALLATION GUIDE BURIED PIPES AWWA



01

<b>1</b>	<b>Introductory Information</b>	<b>4</b>
1.1	Foreword	4
1.2	Soil-Pipe System	4
1.3	Field Technician	5
1.4	Safety	5

02

<b>2</b>	<b>Shipping, Handling and Storage of Pipes</b>	<b>6</b>
2.1	Pipe Inspection	6
2.2	Pipe Repair	6
2.3	Pipe Unloading and Handling	6
2.4	Site Pipe Storage	7
2.5	Gaskets and Lubricant Storage	7
2.6	Pipe Transportation	8
2.7	Handling Nested Pipes	8

03

<b>3</b>	<b>Pipe Installation Procedure</b>	<b>9</b>
3.1	Standard Trench	9
3.2	Pipe Bedding	9
3.3	Backfill Materials	10
3.4	Installation Types	10
3.5	Backfilling a Pipe	11
3.6	Compaction Above Pipes	12
3.7	Pipe Deflections	13

04

<b>4</b>	<b>Pipe Joining</b>	<b>14</b>
4.1	Flowtite Double Bell Couplings	14
4.2	Locked Joints	16
4.3	Flanged Joints	16
4.4	Butt Wrap Joint	18
4.5	Other Joining Methods	18

05

<b>5</b>	<b>Thrust Restraints, Concrete Encasement and Connections to Rigid Structures</b>	<b>20</b>
5.1	Concrete Encasement	21
5.2	Connections to Rigid Structures	23
5.3	Casings (Tunnels)	25
5.4	Concrete-wall Connections	25

06

<b>6</b>	<b>Field Adjustments</b>	<b>26</b>
6.1	Length Adjustment	26
6.2	Field Closures with Flowtite Couplings	26
6.3	Field Closures with Non-Flowtite Couplings	27

<b>7 Other Installation Procedures and Considerations</b>	<b>28</b>
7.1 Multiple Pipes in Same Trench.....	28
7.2 Cross-Overs.....	28
7.3 Unstable Trench Bottom.....	28
7.4 Flooded Trench.....	29
7.5 Use of Trench Supports.....	29
7.6 Trench Construction in Rock.....	29
7.7 Inadvertent Over-Excavation.....	30
7.8 Installation of Pipes on Slopes (Parallel).....	30
<b>8 Accommodating Valves and Chambers</b>	<b>31</b>
8.1 Anchoring In-Line Valves.....	31
8.2 Air and Vacuum Valves.....	34
8.3 Clean Out and Scour Valves.....	36
<b>9 Post-Installation</b>	<b>37</b>
9.1 Checking the Installed Pipe.....	37
9.2 Pipe Misalignment.....	37
9.3 Field Hydrotesting.....	38
9.4 Field Joint Tester.....	39
9.5 Field Air Test.....	39
9.6 Cleaning of Flowtite Pipes.....	40
<b>10 Alternative Installations</b>	<b>42</b>
10.1 Wide Trench.....	42
10.2 Cement Stabilised Backfill.....	42
<b>Appendix</b>	<b>44</b>
Appendix AWWA M 45 or ATV 127	

07

08

09

10

app.

# 1 Introductory Information

## 1.1 Foreword

This document is part of the Flowtite documentation for the users of Flowtite products. It is to be used in connection with the Flowtite Product Guide and is intended to assist the installer in understanding the requirements and procedures for the successful handling of buried installation of Flowtite pipes. The appendices may serve as a helpful source of data for the owner's engineers.

This document mainly addresses the usual circumstances that may be encountered in the field; unique situations requiring special considerations are not addressed and should be resolved in cooperation with the supplier.

Installations other than direct bury, such as trenchless, sub-aqueous or above-ground, are not discussed in this manual. Consult the supplier for suggested procedures and limitations in these cases.

Most importantly, this installation guide is not meant to replace common sense, good engineering requirements and judgement, applicable laws, safety, environmental or other regulations or local ordinances, nor the specifications and instructions of the owner and/or the owner's engineer, who is/are the final authority on each job. Should any conflicting information in this brochure create doubts as to how to proceed properly, please consult the supplier and the owner's engineer.

The installation procedures outlined in this Installation Guide and the suggestions of the Field Technicians, when carefully followed, will help with the thorough execution of a proper, long-lasting installation. Consult the supplier on any questions or when variations from this installation guide are being considered.

**!** **Note:** These installation instructions are based on the structural design procedures of AWWA M45, but are also valid for ATV 127. The main text is essentially aligned with AWWA, while the appendices contain information that is specific to either ATV or AWWA. A specific ATV version of the installation manual is available on request.

## 1.2 Soil-Pipe System

The versatility of soil behaviour, along with the strength and flexibility of Flowtite pipes, offers a unique potential for soil-structure interaction that allows optimum system performance. The glass fibre reinforcement is placed where needed in the pipe for flexibility and strength, while trench geometry, along with selection, placement and compaction of backfill, ensures the integrity of the system.

Broadly, there are two sets of loads that the pipe is subject to:

- 1** external loads resulting from overburden, surface loads and traffic, creating bending stresses in the pipe wall;
- 2** internal pressure creating hoop stresses in the pipe and unbalanced thrust creating axial stresses.

The flexibility of Flowtite pipe, combined with the natural structural behaviour of soils, provide an ideal combination for transferring vertical load. Unlike stiff pipes, which would break under excessive vertical load, the pipe's flexibility, combined with its high strength, allows it to bend and redistribute the load to the surrounding soil. The deflection of the pipe serves as an indicator of the stresses generated in the pipe and the quality of the installation.

Hoop stresses are resisted by placing continuous glass fibre reinforcement circumferentially in the pipe wall. The amount of reinforcement is dictated by the pressure level and determines the pressure class of the pipe.

Unbalanced thrust is usually most economically resisted through thrust blocks that transfer the thrust by direct bearing to the native soil. The standard Flowtite pipe is therefore not required to transfer axial thrust, and the amount of reinforcement in the pipe wall in the axial direction is limited to secondary effects. Consequently, the joints are not required to transfer axial load, but allow for movement of the pipe within the joint due to temperature and Poisson's effect.

In some cases thrust-blocks may be undesirable due to their weight, lack of space, or other reasons. In such cases enough reinforcement is placed in the pipe wall in the axial direction to carry the direct thrust. Restraint joints for such systems are designed to carry the full axial thrust, and the thrust is transferred to the surrounding soil through direct bearing and friction.

## 1.3 Field Technician

The supplier can, at the request of the purchaser and within the terms of the agreement between the purchaser and the supplier, provide a Field Technician. The Field Technician can advise the purchaser and/or the installer to help achieve a satisfactory pipe installation. It is recommended that “on the job” field service should be engaged in the initial stage of installation and may continue periodically throughout the project. The service may range from continuous (essentially full time) to intermittent, depending on agreement between purchaser and supplier.

## 1.4 Safety

Operations in trenches are carried out in potentially hazardous conditions. Where appropriate, shore, sheet, brace, slope or otherwise support the trench walls to protect any person in the trench. Take precautions to prevent objects falling into the trench, or its collapse caused by the position or movements of adjacent machinery or equipment, while the trench is occupied. Excavated material should be deposited at a safe distance from the edge of the trench, and the proximity and height of the soil bank should not be allowed to endanger the stability of the excavation.

Local health & safety instructions, as well as environmental regulations for construction work should be always taken into consideration. Detailed health & safety information about the work with Flowtite products is available at your local supplier. Glass-reinforced polyester (GRP) is not recommended for use in applications which are exposed to intense heat or flames. During installation, care must be taken to avoid exposure of the pipe to welder’s sparks, cutting-torch flames or other heat/flame/electrical sources, which could ignite the pipe material. This precaution is particularly important when working with volatile chemicals in making layup joints, repairing or modifying the pipe in the field.



## 2 Shipping, Handling and Storage of Pipes

01

02

03

04

05

06

07

08

09

10

app.

### 2.1 Pipe Inspection

All pipes should be inspected upon receipt at the job site to insure that no damage has occurred in transit. Depending on length of storage, amount of job site handling and other factors that may influence the pipes' condition, it is recommended that the pipe is re-inspected just prior to installation.

Inspect the shipment upon delivery, as follows:

- 1 Make an overall inspection of the load. If the load is intact, ordinary inspection while unloading will normally be sufficient to make sure the pipe has arrived without damage.
- 2 If the load has shifted or indicates rough treatment, carefully inspect each pipe section for damage. Generally, an exterior inspection will be sufficient to detect any damage. When pipe size permits, an interior inspection of the pipe surface at the location of an exterior scrape may be helpful to determine if the pipe is damaged.
- 3 Check the quantity of each item against the bill of lading.
- 4 Note on the bill of lading any transit damage or loss and have the carrier representative sign your copy of the receipt. Claims against the carrier should be in accordance with their instructions.
- 5 If any imperfections or damage is found, segregate the affected pipes and contact the supplier.

Do not use pipe that appears damaged or defective. Both, internal and external surfaces, shall be free from any irregularities that might impair the ability of the component to conform to the requirements.

### 2.2 Pipe Repair

Normally, pipes with minor damages can be repaired quickly and easily at the job site by a qualified individual. If in doubt about the condition of a pipe, do not use it.

The Field Technician can help you determine whether repair is required and whether it is possible and practical. Repair designs can vary greatly due to pipe thickness, wall composition, application, and the type and extent of the damage. Therefore, do not attempt to repair a damaged pipe without consulting the supplier first. Repairs must be made by a trained repair technician. Improperly repaired pipes may not perform as intended.

### 2.3 Pipe Unloading and Handling

Unloading the pipe is the responsibility of the customer. Be sure to maintain control of the pipe during unloading. Guide ropes attached to pipes or packages will enable easy manual control when lifting and handling. Spreader bars may be used when multiple support locations are necessary. Do not drop, impact or bump the pipe, particularly at pipe ends.

#### Single Pipes

When handling single pipes, use pliable straps, slings or rope to lift. Do not use steel cables or chains to lift or transport the pipe. Pipe sections can be lifted with only one support point (**Figure 2-1**), while two support points (**Figure 2-2**) is the preferred method for safety reasons, as it makes the pipe easier to control. Do not lift pipes using hooks at pipe ends or by passing a rope, chain or cable through the section end to end. See **Appendix A** for approximate weights of standard pipes and couplings.

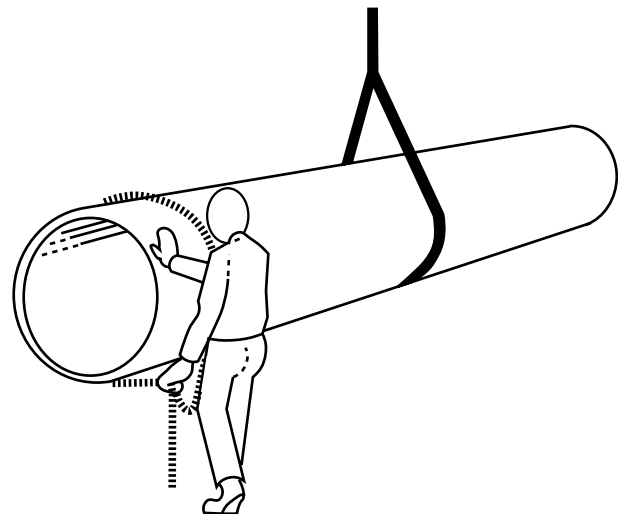

Figure 2-1 Lifting a pipe at one support point

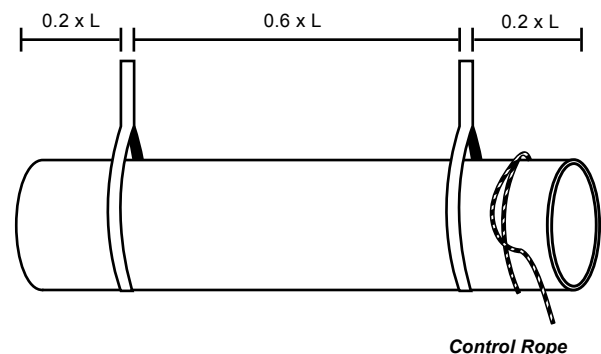

Figure 2-2 Lifting a pipe at two support points

• **Unitized Loads**

Unitized loads may be handled using a pair of slings as shown in **Figure 2-3**. Do not lift a non-unitized stack of pipes as a single bundle.

Non-unitized pipes must be unloaded and handled separately (one at a time).

If at any time during handling or installation of the pipe, any damage such as a gouge, crack or fracture occurs, the pipe should be repaired before the section is installed.

Contact the supplier for inspection of damages and for recommendation of repair method or disposal. See **section 2.2** →.

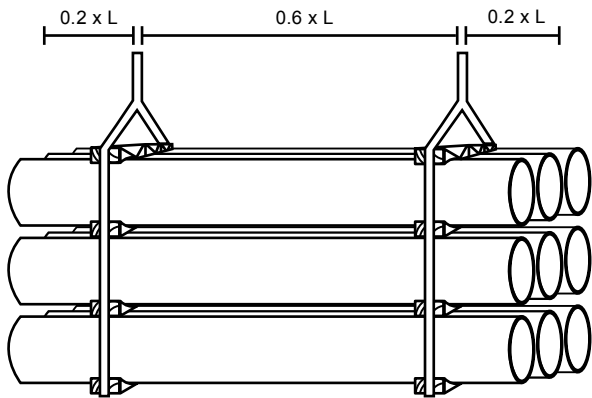

**Figure 2-3** Lifting a unitized package

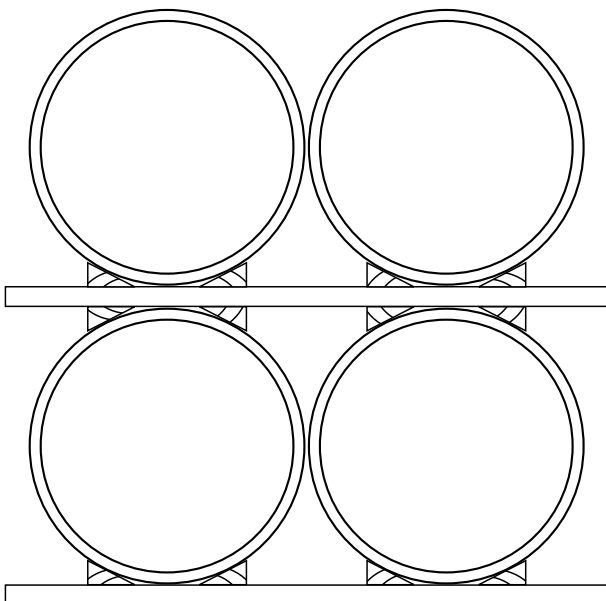

**Figure 2-4** Pipe storage

## 2.4 Site Pipe Storage

It is generally advantageous to store pipes on flat timber to facilitate placement and removal of lifting slings around the pipe.

When storing pipes directly on the ground, be sure that the area is relatively flat and free of rocks and other potentially damaging debris. Placing a pipe on mounds of backfill material has been found to be an effective way of site pipe storage. All pipes should be chocked to prevent rolling in high winds.

If it is necessary to stack pipes, it is best to stack on flat timber supports (minimum width of 75 mm) at quarter point with chocks (**see Figure 2-4**). If possible, use the original shipping dunnage.

Insure the stack will be stable for conditions such as high winds, uneven storage surface or other horizontal loads. If strong winds are anticipated consider using ropes or slings to tie pipes down. Maximum stack height is approximately 3 metres.

Bulges, flat areas or other abrupt changes of pipe curvature are not permitted. Storing of pipes outside of these limitations may result in damage to the pipes.

## 2.5 Gaskets and Lubricant Storage

Rubber ring gaskets, when shipped separately from the couplings, should be stored in the shade in their original packing and should not be exposed to sunlight except during the pipe joining. Also, the gaskets must be protected from exposure to petroleum-derived greases and oils, as well as solvents and other harmful substances.

Gasket lubricant should be carefully stored to prevent damage. Partially used buckets should be resealed to prevent contamination of the lubricant. If temperatures during installation are below 5° C, gaskets and lubricant should be sheltered until used. A special lubricant for lower temperatures than 5° C is available on request.

## 2.6 Pipe Transportation

Support all pipe sections on flat timbers, spaced at maximum 4 metres (3 metres for diameter  $\leq$  DN250), with a maximum overhang of 2 metres. Chock the pipes to maintain stability and separation. Avoid abrasion.

Maximum stack height is approximately 2.5 metres. Strap the pipe to the vehicle over the support points using pliable straps or rope (**Figure 2-5**). Never use steel cables or chains without adequate padding to protect the pipe from abrasion. Bulges, flat areas or other abrupt changes of curvature are not permitted. Transport of pipes outside of these limitations may result in damage to the pipes.

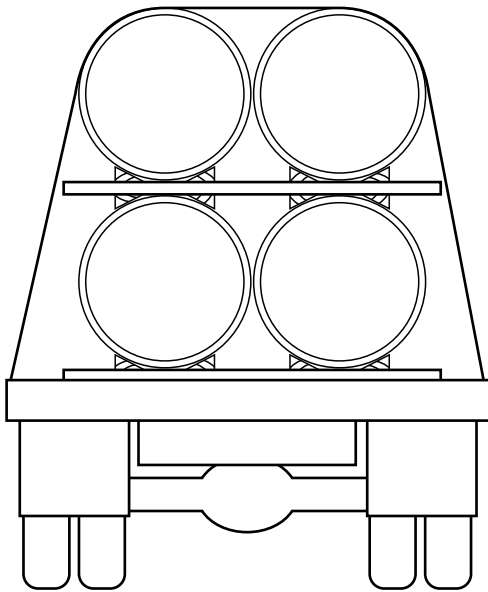

**Figure 2-5** Transportation of pipes

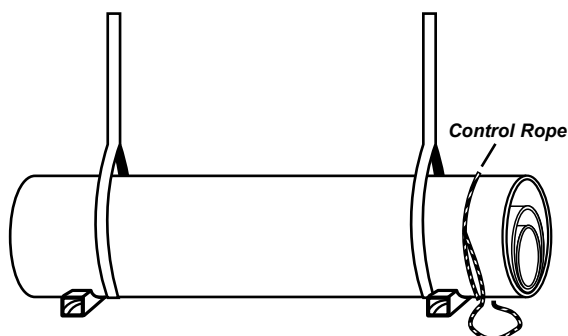
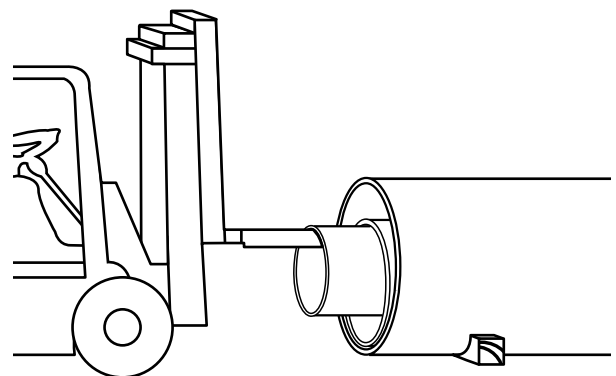

**Figure 2-6** Double support for nested pipes

## 2.7 Handling Nested Pipes

Pipes may be nested (smaller diameter pipes inside of larger sizes). These pipes generally have special packaging and may require special procedures for unloading, handling, storing and transporting. Special measures, if required, will be carried out by the pipe supplier prior to shipment. However, the following general procedures should always be followed:

- 1** Always lift the nested bundle using at least two pliable straps (**Figure 2-6**). Limitations, if any, for spacing between straps and lifting locations will be specified for each project. Ensure that the lifting slings have sufficient capacity for the bundle weight. This may be calculated from the approximate pipe weights given in **Appendix H** →.
- 2** Nested pipes are usually best stored in the transport packaging. Stacking of these packages is not advised unless otherwise specified.
- 3** Nested pipe bundles can only be safely transported in the original transport packaging. Special requirements, if any, for support, configuration and/or strapping to the vehicle will be specified for each project.
- 4** Package removal and de-nesting of the inside pipe(s) is best accomplished at a de-nesting station. Inside pipes, starting with the smallest size, may be removed by lifting slightly with an inserted padded boom to suspend the section and carefully move it out of the bundle without damaging the other pipes (**Figure 2-7**). When weight, length and/or equipment limitations preclude the use of this method, procedures for sliding the inside pipe(s) out of the bundle will be recommended for each project.



**Figure 2-7** De-nesting with padded boom on forklift truck



# 3 Pipe Installation Procedure

- 01
- 02
- 03
- 04
- 05
- 06
- 07
- 08
- 09
- 10
- app.

The type of installation procedure appropriate for Flowtite pipe varies with pipe stiffness, cover depth, trench width, native soil characteristics, surcharge loads and backfill materials.

The native material must adequately confine the pipe zone backfill to achieve proper pipe support. The following installation procedures are intended to assist the installer in achieving a proper pipe installation.

The static calculation method ATV 127 is frequently used. As an aid, the following is the correlation between the backfill soil stiffness categories of these instructions and the ATV 127 soil groups, G1 to G4:  
 SC I corresponds to the best of the G1 soils. SC II corresponds to the G1 soils and the best of the G2 soils. SC III corresponds to the weaker G2 soils and the best of the G3 soils. SC IV corresponds to the weaker G3 soils and the best of the G4 soils.

## 3.1 Standard Trench

The width of the trench at the springline of the pipe need not be greater than necessary to provide adequate room for jointing the pipe in the trench and compacting the pipe zone backfill at the haunches. Typical values for "A" (see **Figure 3-1**) are given in the **Table 3-1**. Wider trenches may be necessary for installations involving, e.g., relatively deep burial or unstable native soils. Narrower trenches may be used when the system design permits, or access by persons is not required.

**! Note:** Where rock, hard pan, soft, loose, unstable or highly expansive soils are encountered in the trench bottom, it may be necessary to increase the depth of the bedding layer to achieve uniform longitudinal support.

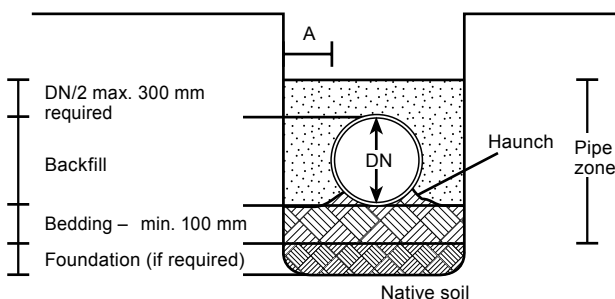

**Figure 3-1 Pipe backfill nomenclature**

Nominal size DN	A mm
DN ≤ 400	200
400 < DN ≤ 900	400
900 < DN ≤ 1600	500
1600 < DN ≤ 2400	600
2400 < DN ≤ 4000	900

**Table 3-1 Typical values for A**

## 3.2 Pipe Bedding

The bedding should be placed over a firm, stable trench bottom so as to provide proper support. The finished bed must provide a firm, stable and uniform support for the pipe barrel and any protruding feature of its joint.

Provide 100 - 150 mm of bedding below the barrel and 75 mm below the coupling. For a soft or unstable trench bottom, an additional foundation may be needed to achieve firm support for the bedding, see **section 7.3**.

To determine if the native material is acceptable as a bedding material, it should meet all of the requirements of the pipe zone backfill. This determination must be made constantly during the pipe installation process because native soil conditions may vary suddenly along the length of a pipeline. The bedding material may need to be imported to provide proper gradation and pipe support.

The bed must be over-excavated at each joint location to ensure that the pipe will have a continuous support and does not rest on the couplings. The coupling area must be properly bedded and backfilled after the joint assembly is completed. See **Figure 3-2** and **Figure 3-3** for proper and improper bedding support.

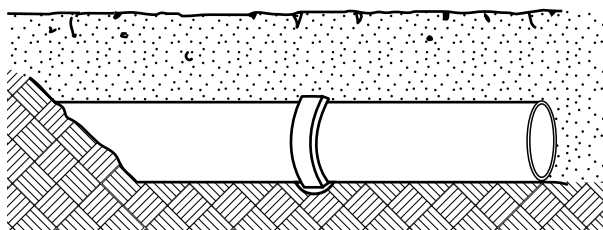

**Figure 3-2 Proper bedding support**

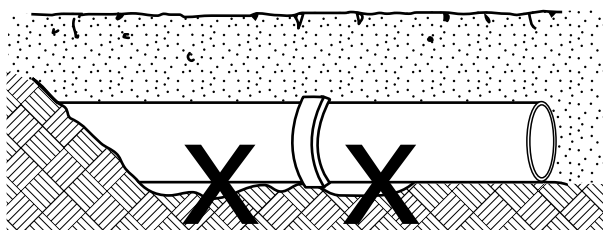

**Figure 3-3 Improper bedding support**

### 3.3 Backfill Materials

For backfill of the pipe zone various materials can be used. The selection should be made based on local, regional and economic aspects. Each material used has to meet the requirements for max. allowable particle size. **Table 3–2** groups backfill materials into soil stiffness classes. SC I and SC II backfill soils are the easiest to use and require the least compaction effort to achieve a given level of relative compaction.

Regardless of the backfill grouping, or whether the backfill soil is imported or not, the following general restrictions apply:

- 1 For the maximum particle size and stone size the limits given in **Table 3–3** must be adhered to.
- 2 No soil clumps greater than twice the maximum particle size.
- 3 No frozen material.
- 4 No organic material.
- 5 No foreign debris (waste, bottles, metals, etc.)

Backfill stiffness classes	Description of Backfill Soils
SC I	Crushed rock with < 15% sand, maximum 25% passing the 10 mm sieve and maximum 5% fines
SC II	Clean, coarse-grained soils with < 12% fines
SC III	Clean, coarse-grained soils with 12% or more fines Sandy or fine-grained soils with less than 70% fines
SC IV	Fine grained soils with more than 70% fines

(See **Appendix D** for further clarification and **Appendix I** for definitions)

**Table 3–2 Backfill materials**

Maximum sieve size in the pipe zone (up to 300 mm over the pipe crown):

DN	Max. Sieve Size (mm)
≤ 450	13
500 - 600	19
700 - 900	25
1000 - 1200	32
≥ 1300	40

**Table 3–3 Maximum particle size**

The backfill above the pipe zone may be made with excavated material with a maximum particle size of up to 300 mm, providing there is at least 300 mm cover over the pipe. Stones exceeding 200 mm should not be dropped from a height greater than 2 m at the 300 mm layer covering the pipe crown.

Processed excavated material or imported backfill may contain oversize particles. The use of crushed rock has proven to be a cost-effective solution. The maximum oversize particle shall be less than 2 x allowable particle size acc. to **Table 3-3**. Oversized content share is limited to 10%. Graded material is recommended for easiest compaction results.

Self-compacting flowable materials such as stabilised ground or liquid soil are a proven alternative solution as backfill material. It should be noted that the suitability of these materials must be proven in terms of soil mechanical parameters acc. to the project design requirements.

Material used for bedding and cover shall comply with the same requirements as for the pipe bed. This particularly concerns the grading composition and compatibility.

### 3.4 Installation Types

Two standard backfilling configurations are recommended (**Figure 3–4 and Figure 3–5**). The selection of type depends on the native soil characteristics, the backfill materials, required depth of burial, prevailing conditions, pipe stiffness and the pipe operating conditions. The Type 2 “split” configuration is generally more utilized for applications of lower pressure (PN ≤ 10 bar), light duty traffic loading and limited negative pressure (vacuum) requirement.

#### Installation Type 1

- Construct the pipe bed following the guidelines of **section 3.2**.
- Backfill the pipe zone (to 300 mm) over the pipe crown with the specified backfill material compacted to the required compaction level (see **Appendix B**).
- ! **Note:** For low pressure (PN ≤ 1 bar) applications without traffic load, the need to compact the 300 mm over the pipe crown may be waived.

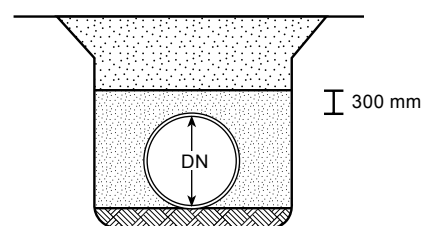

**Figure 3–4 Installation Type 1**

### Installation Type 2

- Construct the pipe bed following the guidelines of **section 3.2**. Backfill to a level of 60% of pipe diameter with the specified backfill material compacted to the required compaction level.
- Backfill from 60% of diameter to 300 mm over the pipe crown with specified backfill material compacted to the required compaction level.
- ! **Note:** Backfill Configuration Type 2 is not practical for small diameter pipes.
- ! **Note:** Backfill Configuration Type 2 is not suitable for heavy traffic loading situations.

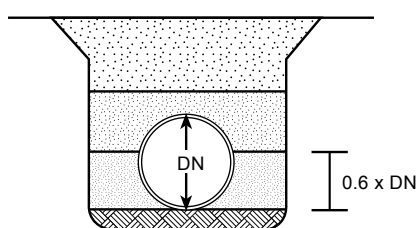

Figure 3-5 Installation Type 2

## 3.5 Backfilling a Pipe

Immediate backfilling after joining is recommended as it will prevent two hazards, i.e. floating the pipe due to heavy rain and thermal movements due to large temperature fluctuations. Floating of the pipe can cause damage and create unnecessary reinstatement costs, whilst the cumulative effect thermal expansion and contraction over several lengths can compromise seal integrity at one joint.

If pipe sections are placed into the trench and backfilling is delayed, each pipe should have the centre section backfilled to the crown to help minimize movements at the joint.

The proper selection, placement and compaction of pipe zone backfill is important for controlling the vertical deflection and is critical for pipe performance. Care must be taken so that the backfill material is not contaminated with debris or other foreign materials that could damage the pipe or cause loss of support. The haunching material in the area between the bedding and the underside of the pipe must be worked in and compacted before placing the remainder of the backfill (see Figure 3-6 and Figure 3-7).

The depth of the layer being compacted as well as the energy placed into the compaction method must be well controlled. Proper backfilling is typically done in 100 mm to 300 mm lifts, depending on backfill material and

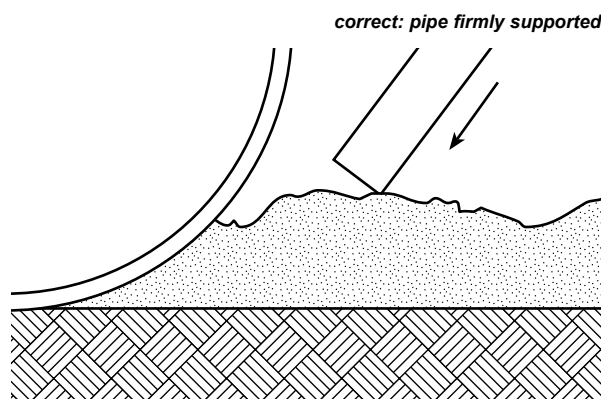

Figure 3-6 Proper haunch backfill

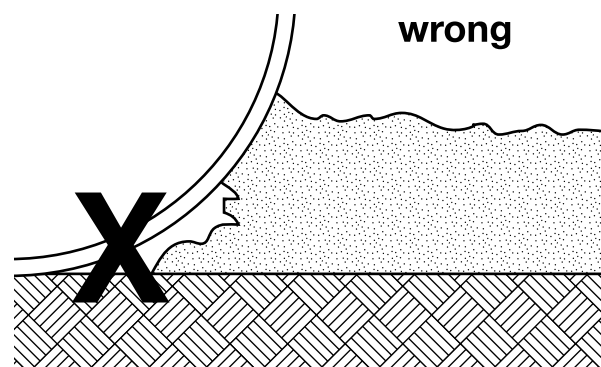

Figure 3-7 Improper haunch backfill

compaction method. When gravel or crushed stone is used as backfill material, 300 mm lifts will generally be adequate, since gravel is relatively easy to compact. Finer grained soils need more compaction effort and the lift height should be limited. Note that it is important to achieve proper compaction of each lift to ensure that the pipe will have adequate support.

Backfill classes SC I and SC II are relatively easy to use and very reliable as backfill materials for pipe. These soils have low moisture sensitivity. Backfill can be easily compacted using a plate vibrator compactor in 200 to 300 mm lifts. Occasionally, a filter fabric should be used in combination with gravel soils to preclude fines migration and subsequent loss of pipe support. See **Appendix A** for criteria.

Backfill class SC III soils are acceptable and are often readily available as backfill materials for pipe installations. Many local soils, in which the pipe is installed, are SC III and therefore the excavated soil can be directly reused as pipe-zone backfill. Precaution is to be taken with these soils as they can be moisture sensitive. The characteristics of class SC III soil are often dictated by the characteristics of the fines. Moisture control may be required when compacting the soil to achieve the desired density with reasonable compaction energy and easily used compaction equipment. Compaction can be achieved by using impact compactor in 100 to 200 mm lifts.

Backfill class SC IV can only be used as pipe-zone backfill with the following precautions:

- Moisture content must be controlled during placement and compaction.
- Do not use in installations with unstable foundations or with standing water in the trench.
- Compaction techniques may require considerable energy and practical limitations of relative compaction, and resulting soil stiffness must be considered.
- When compacting, use lifts of 100 and 150 mm with an impact compactor such as Whacker or pneumatic rammer (pogo stick).
- Compaction tests should be conducted periodically to assure that proper compaction is achieved. See **Appendix F** for further information →.

The compaction of finer grain backfill is most easily accomplished when the material is at or near its optimum moisture content. When backfilling reaches pipe spring-line, all compaction should start near the trench sides and proceed towards the pipe. Pipe zone backfill can be placed and compacted in such a way as to cause the pipe to ovalise slightly in the vertical direction. Initial vertical ovalisation, however, must not exceed 1.5% of pipe diameter as measured when backfill reaches pipe crown. The amount of initial ovalisation obtained will be related to the energy required to achieve the relative compaction needed. The high energy levels that may be necessary with backfill classes SC III and SC IV may lead to exceeding the limit. If this occurs consider a higher stiffness pipe or other backfill materials or both.

! Please note that over-compaction in the haunching area might lead to a pipe misplacement in the horizontal or vertical direction.

These recommendations are summarised in **Table 3–4**.

Blackfill stiffness classes	Hand-operated Impact Compactor	Hand-operated Vibrating Plate Compactor	Recommendations
SC I		300 mm	Two passes should provide good compaction
SC II		200 - 250 mm	Two to four passes, depending on height and required density
SC III	100 - 200 mm		Layer height and number of passes are dependent on required density. Use at or near optimum moisture content. Check compaction.
SC IV	100 - 150 mm		May require considerable compaction energy. Control moisture content to be at optimum. Verify compaction.

**Table 3–4 Summary of recommendations for compaction of pipe-zone backfill**

### 3.6 Compaction Above Pipes

Type 1 installation requires the 300 mm over the pipe to be compacted. Trench backfill under areas subjected to traffic load is often compacted to minimize road surface settlement. **Table 3–5** shows the minimum cover height over the pipe necessary, before certain compaction equipment may be used directly above the pipe. Care must be taken to avoid excessive compaction effort above the pipe crown which may cause bulges or flat areas. However, the material in this area must not be left loose and the desired specific density should be achieved.

Equipment	Minimum thickness over pipe crown before compaction m	Equipment	Minimum thickness over pipe crown before compaction m
Foot or hand tamper min. 15 kg	0.20	Vibrating roller min. 15 kN/m	0.60
		min. 30 kN/m	1.20
		min. 45 kN/m	1.80
		min. 65 kN/m	2.40
Vibrating tamper min. 70 kg	0.30	Twin vibrating roller min. 5 kN/m min. 10 kN/m min. 20 kN/m min. 30 kN/m	0.20
			0.45
			0.60
			0.85
Plate vibrator min. 50 kg min. 100 kg min. 200 kg min. 400 kg min. 600 kg	0.15	Triple heavy roller (no vibration) min. 50 kN/m	1.00
	0.15		
	0.20		
	0.30		
	0.50		

**Table 3–5 Minimum cover for compaction above a pipe**

### 3.7 Pipe Deflections

Deflection of the backfilled pipe is a good indicator of the quality of the installation. The expected initial vertical pipe deflection after backfilling to grade level is less than 2% for most installations. A value exceeding this amount indicates that the desired quality of the installation has not been achieved and should be improved for the next pipes (i.e. increased pipe zone backfill compaction, coarser grained pipe zone backfill materials or wider trench, etc.).

The consistency of the installation needs to be checked continuously. Differential deflections of adjacent pipe spigots must be kept within the allowable joint limitations as defined in **section 4** →. Particular attention shall be taken on pipe misalignment or varying deflection between two pipe spigots within one joint as a sign of non-uniform bedding conditions for the pipes.

Deviations can be corrected by improved backfill and compaction work. **Table 3–6** gives the maximum allowable initial deflection. It is recommended to check the pipe deflection as soon as the pipe has been backfilled to grade level in order to get a continuous feedback on installation quality, see **section 9.1** →.

	Deflection % of Diameter
Large Diameter (DN ≥ 300) Initial	3.0
Small Diameter (DN ≤ 250) Initial	2.5

**Table 3–6 Allowable initial vertical deflection**

## 4 Pipe Joining

Flowtite pipe sections are typically joined using Flowtite couplings. Pipe and couplings may be supplied separately or the pipe may be supplied with a coupling installed on one end. If the couplings are not delivered pre-mounted, it is recommended that they be mounted at the storage yard or at the trench side before the pipe is lowered to the trench bed.

The couplings may be supplied with or without a rubber centre stop register. If a centre register is not supplied, a home-line will be marked on the pipe as an aid for joining.

Other joining system such as flanges, mechanical couplings and lay-up joints may also be used for joining Flowtite pipes.

### 4.1 Flowtite Double Bell Couplings

#### Flowtite Pressure Coupling (FPC)

The following steps (1-5) are meant for Flowtite Pressure Couplings.

##### Step 1 Foundation and Bedding

The bed must be over-excavated at each joint location to ensure that the pipe will have continuous support and does not rest on the couplings. The coupling area must be properly bedded and backfilled after the joint assembly is completed.

##### Step 2 Coupling Cleaning

Thoroughly clean the double bell coupling grooves and rubber gasket rings to make sure no dirt or oil is present (*Figure 4-1*).

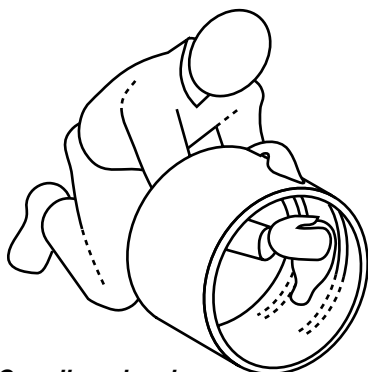

*Figure 4-1 Coupling cleaning*

##### Step 3 Gaskets Installation

Insert the gasket into the groove leaving loops (typically two to four) of rubber extending out of the groove. Do not use any lubricant in the groove or on the gasket at this stage of assembly. Water may be used to moisten the gasket and groove to ease positioning and insertion of the gasket (*Figure 4-2*).

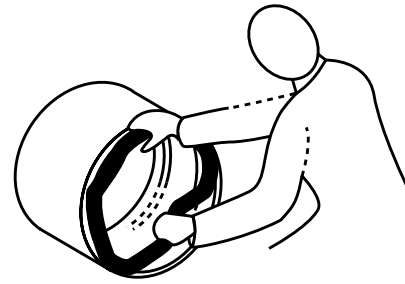
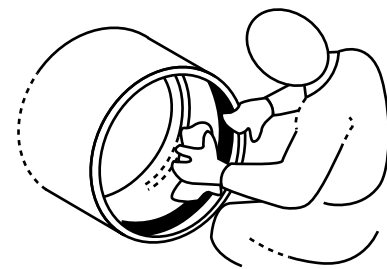

*Figure 4-2 Installation of the gasket*

With uniform pressure, push each loop of the rubber gasket into the gasket groove. When installed, pull carefully in the radial direction around the circumference to distribute compression of the gasket. Check also that both sides of the gasket protrude equally above the top of the groove around the whole circumference. Tapping with a rubber mallet will be helpful to accomplish the above.

##### Step 4 Gaskets Lubrication

Next, apply a thin layer of lubricant to the rubber gaskets (*Figure 4-3*). See *Appendix I* for normal amount of lubricant consumed per joint.

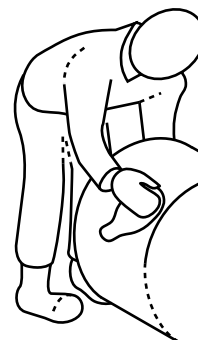

*Figure 4-3 Lubrication of the gasket*

##### Step 5 Spigots Cleaning and Lubrication

Thoroughly clean pipe spigots to remove any dirt, grit, grease, etc. Inspect spigot sealing surface for possible damage. Apply a thin layer of lubricant to the spigots from the end of the pipe to the black alignments stripe. After lubricating, take care to keep the coupling and spigots clean (*Figure 4-4*). It has been found that placing a cloth or plastic sheet, approximately one metre square, under the jointing area will keep the spigot ends and gasket clean. Lubricants suitable for low temperatures are available on request.

**! Caution:** It is very important to use only the correct lubricant. The supplier provides sufficient lubricant with each delivery of couplings. If for some reason you run out, please contact the supplier for additional supply or advice on alternative lubricants. Never use a petroleum based lubricant.



*Figure 4-4 Spigot cleaning*

## Joining

If the coupling is not pre-mounted it should be mounted on the pipe in a clean, dry place before the pipes are joined. This is accomplished by placing a clamp or a sling around the pipe at a distance of 1 to 2 m from the spigot on to which the coupling will be mounted. Make sure the pipe spigot is resting at least 100 mm above the ground surface to keep away from dirt. Push the coupling on to the pipe spigot end manually and place a 100 x 50 mm timber across the coupling. Use two come-along jacks connected between the timber and the clamp and pull the coupling into position i.e. until the coupling is aligned with the “home line” or until the spigot touches the centre register (see Figure 4-5).

The following steps (6 to 8) apply to joining pipes using clamps or slings and “come-along jacks”. Other techniques may also be used providing the general objectives outlined here are met. In particular, insertion of the pipe spigot ends should be limited to the home-line and any damage to the pipe and coupling avoided.

### Step 6 Pipe Placement

The pipe with the coupling mounted is lowered onto the trench bed. In the location of the joint the trench should be over-excavated to ensure that the pipe will have a continuous support, is well aligned and does not rest on the couplings.

### Pipe Misalignment

The maximum allowable misalignment of adjacent pipe ends is 5 mm (see Figure 4-5). It is recommended to monitor misalignment near thrust blocks, valve chambers and similar structures, and at closure or repair locations.

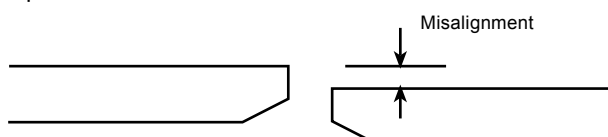

Figure 4-5 Misalignment

### Step 7 Fixing of Clamps

Clamp (or sling) A is fixed anywhere on the first pipe or left in position from the previous joint. Fix the Clamp (or sling) B on the pipe to be connected in a convenient position (Figure 4-6).

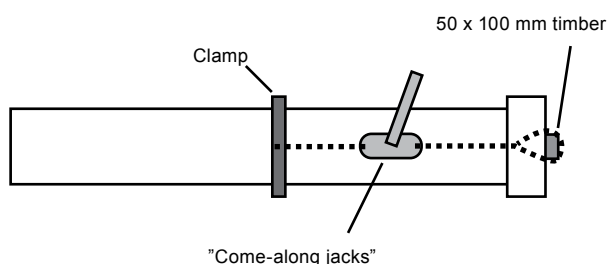

Figure 4-6 Mounting of a coupling

**! Note:** Clamp contact with the pipe shall be padded or otherwise protected to prevent damage to the pipe as well as impart high friction resistance with the pipe surface. If clamps are not available, nylon slings or rope may be used, but care must be taken in the alignment of the coupling.

### Step 8 Coupling Joining

Come-along jacks are placed on either side of the pipe and connected to the clamps. The pipe is pulled into position into the coupling until it reaches the home-line or touches the centre register. Clamp A is then moved onto the next pipe to be joined.

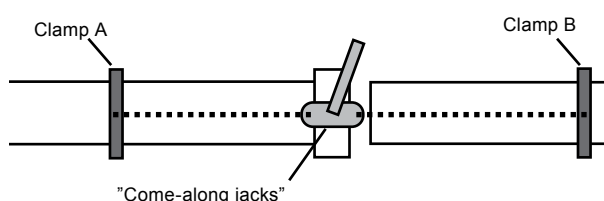

Figure 4-7 Pipe joining, using clamps

The pipes can also be mounted by an excavator shovel or a crowbar (up to DN 300). The spigot ends are to be protected from any damage. The approximate mounting force can be calculated as follows:

$$\text{Mounting forces in tons} = (\text{DN in mm} / 1000) \times 2$$

**! Note:** Shovel installation requires great experience in pipe handling. Care must be taken to avoid damages on pipes and couplings.

### Flowtite Sewer Coupling (FSC)

A gasket is used for the FSC, which is pre-equipped by the supplier and fixed to the coupling groove. With that, the steps described under section 4.1 – cleaning of the grooves and installing of the gasket – can be skipped. All other working instructions and user data are identical with the steps mentioned under 4.1 for the Flowtite Pressure Coupling.

### Angular Deflection of Flowtite Couplings

Maximum angular deflection in service at each coupling, taking into account the combined vertical and horizontal deflection, must not exceed the values given in Table 4-1. This can be utilized to accommodate gradual changes in line direction. The pipes should be then joined in straight alignment and thereafter deflected angularly as required. The maximum offset and corresponding radius of curvature are shown in Table 4-2 (See Figure 4-8 for definitions of terms). For the installation requiring greater angles, special joint systems are available. For availability, please contact your local supplier.

Nom. Pipe Diameter (mm)	Pressure (PN) in bars			
	Up to 16	20	25	32
		Max. Angle of Deflection (deg)		
DN ≤ 500	3.0	2.5	2.0	1.5
500 < DN ≤ 900	2.0	1.5	1.3	1.0
900 < DN ≤ 1800	1.0	0.8	0.5	0.5
DN > 1800	0.5	0.4	0.3	NA

**Table 4-1 Angular deflection at a double coupling joint**

Angle of Deflection (deg)	Maximum Offset (mm) Pipe length			Radius of Curvature (m) Pipe length		
	3 m	6 m	12 m	3 m	6 m	12 m
3.0	157	314	628	57	115	229
2.5	131	262	523	69	138	275
2.0	105	209	419	86	172	344
1.5	79	157	314	115	229	458
1.3	68	136	272	132	264	529
1.0	52	105	209	172	344	688
0.8	42	84	168	215	430	859
0.5	26	52	105	344	688	1375

**Table 4-2 Offset and radius of curvature**

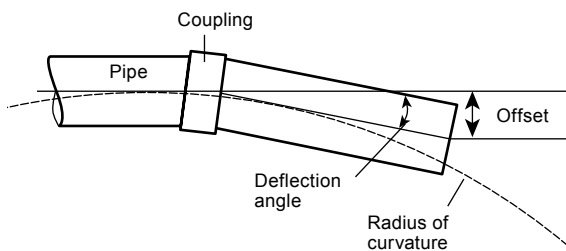

**Figure 4-8 Flowtite coupling, angular joint deflection**

**Note:** The above is for information purposes. The minimum allowable length is a function of nominal pressure and backfill class and compaction, but in general it should be not less than 3 metres.

Angular deflected coupling joints are stabilised by the stiffness of the soil surrounding the pipe and coupling. Pressure pipes (PN>1) should have angularly rotated joints backfilled to minimum 90% standard proctor compaction. Coupling joints that are placed with vertical angular rotation, where the direction of the thrust is upward, should be backfilled to a minimum cover depth of 1.2 metres for operating pressures of 16 bar and greater.

## 4.2 Locked Joints (FBC)

The Flowtite locked joint is a double bell with rubber gaskets and locking rods to transfer axial thrust from one pipe section to another. On each side, the coupling bell has a standard rubber gasket and a rod-groove system, through which the load is transferred. The pipe spigot for locked joints has a matching groove (see **Figure 4-10**).

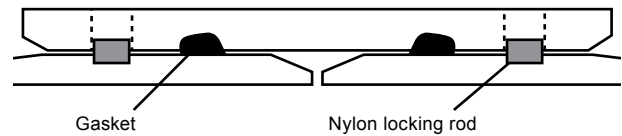
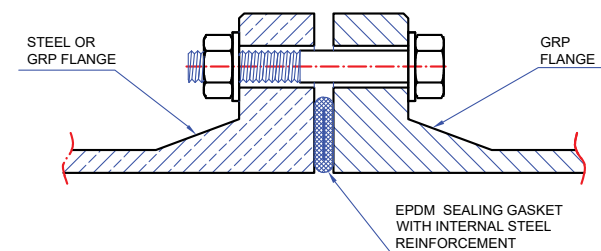

**Figure 4-10 Flowtite locked joint**

The joint is assembled by using a similar procedure as the standard Flowtite pressure coupling, except that there is no centre register. Steps 1 through 6 above should be followed. For step 7 the pipe is pulled in position until the groove in the pipe is visible through the opening in the coupling. The locking rod is then pushed into position with a hammer. Generally, an excavator installation is not recommended. Lock joints shall be installed only in straight alignment. Pipeline must be backfilled before pressure testing.

## 4.3 Flanged Joints

### 4.3.1 GRP Fixed Flange. Flat Face.

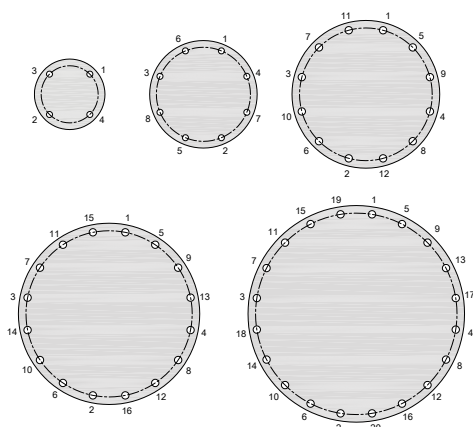

**Figure 4-11 GRP Fixed Flange**

GRP flanges should be joined according to the following procedure: (**Figure 4-11**)

- 1** Thoroughly clean the flange face.
- 2** Ensure the sealing gasket is clean and undamaged. Do not use defective gaskets.
- 3** Position sealing gasket in the flat face. It is recommended that the gasket is secured with small stripes of tape or adhesive.
- 4** Align flanges to be joined.
- 5** Insert bolts, washers and nuts. All hardware must be clean and lubricated to avoid incorrect tightening. It is important that the mating surface between the bolt head/washers and backing ring plate are well lubricated to avoid excessive torque build up.
- 6** Washers must be used on all GRP flanges.
- 7** Using a torque wrench, tighten all bolts following a pattern of tightening sequences (**Figure 4-12**). It is important to tighten bolts in several stages: adjust each bolt to 25% of allowable torque (\*).



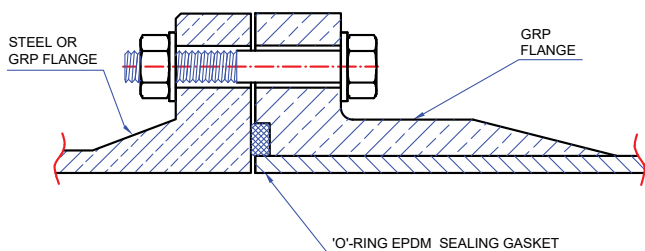

**Figure 4-12 Tightening sequences**

- 8** Repeat this procedure, raising the bolt torque to 50% of the allowable torque and then repeat again to 70%. Do not exceed this torque. To do so may cause permanent damage to GRP flanges.
- 9** Check bolt torques one hour later and adjust if necessary to 70%.

(\*) Ask your local supplier for the most suitable gasket type and allowable bolting torque on each case.

**4.3.2 GRP Fixed Flanges. Using ‘O’-Ring Gasket.**



**Figure 4-13 GRP fixed flange. Using ‘O’-ring gasket.**

GRP flanges using ‘O’-ring gasket should be joined according to the following procedure: **(Figure 4-13)**

- 1** Thoroughly clean the flange face and the ‘O’-ring groove.
- 2** Ensure the sealing gasket is clean and undamaged. Do not use defective gaskets.
- 3** Position sealing gasket in the flat face. It is recommended that the gasket is secured with small strips of tape or adhesive.
- 4** Align flanges to be joined.
- 5** Insert bolts, washers and nuts. All hardware must be clean and lubricated to avoid incorrect tightening. It is important that the mating surface between the bolt head/washers and backing ring plate are well lubricated to avoid excessive torque build up.

- 6** Washers must be used on all GRP flanges.
  - 7** Using a torque wrench, tighten all bolts following a pattern of tightening sequences **(Figure 4-12)**. It is important to tighten bolts in several stages: tighten all bolts to 35 Nm torque, (20 Nm for small diameter - DN 250).
  - 8** Repeat this procedure, raising the bolt torque to 70 Nm, (35 Nm for small diameter) or until the flanges touch at their inside edges. Do not exceed this torque. To do so may cause permanent damage to GRP flanges.
  - 9** Check bolt torques one hour later and adjust if necessary to 70 Nm (35 Nm for small diameter).
- !** **Note:** When connecting two GRP flanges made with an ‘O’-ring gasket, only one flange shall have a gasket groove in the face.

PN	Maximum torque Nm (**)
6	50 x Pipe OD (in m)
10	100 x Pipe OD (in m)
16, 20	200 x Pipe OD (in m)
25	225 x Pipe OD (in m)

(\*\*) Based on standard flange dimensions according to ISO 7005 and EN 1092

**Table 4-3 Torque settings for ‘O’-ring gasket type.**

**4.3.3. GRP Loose Ring Flanges**

Flowtite pipe can also be supplied with loose ring flanges. The loose ring can be rotated to easily align with the bolt holes in the mating flange. The loose ring flange is manufactured for a profile gasket with steel ring for flat flange surfaces (no groove required) as shown in **Figure 4-14**.

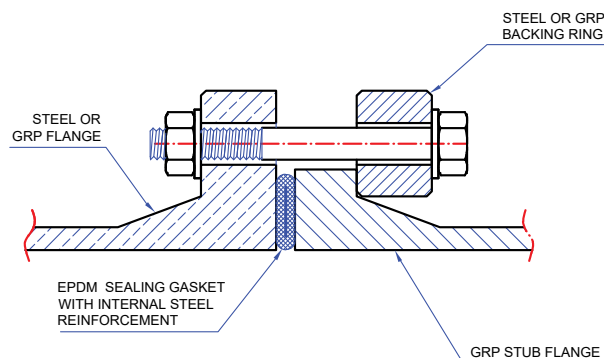
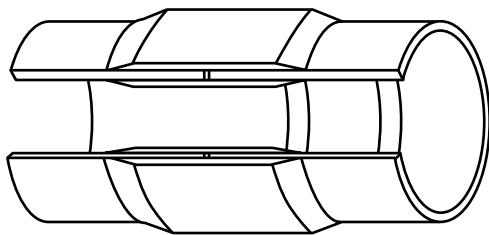

**Figure 4-14 GRP loose ring flange**

The joining procedure for the GRP loose ring flange is identical to the GRP Fixed Flange, described in subsection 4.3.1.

## 4.4 Butt-Wrap Joint

This type of joint is made from glass fibre reinforcements impregnated with polyester resin. It requires special designs, clean, controlled conditions and skilled, trained personnel. Special instructions will be provided when this type of joint is required (see **Figure 4–14**).



**Figure 4–14** Butt-wrap joint

## 4.5 Other Joining Methods

### Flexible Steel Couplings

(Straub, Tee-Kay, Arpol, etc. – see **Figure 4–15**)

When connecting Flowtite pipe to other pipe materials with different outside diameters, flexible steel couplings are one of the preferred joining methods. These couplings consist of a steel mantle with an interior rubber sealing sleeve. They may also be used to join Flowtite pipe sections together, for example in a repair or for closure.

Three grades are commonly available:

- 1 Coated steel mantle
- 2 Stainless steel mantle
- 3 Hot dip galvanized steel mantle

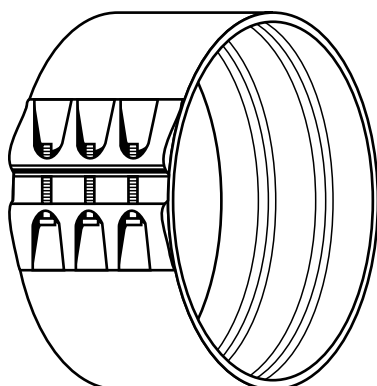

**Figure 4–15** Flexible steel coupling

Control of the bolting torque of flexible steel couplings is important. Do not over torque as this may over stress the bolts or the pipe. Follow the coupling manufacturer's recommended assembly instructions, but with the pipe supplier's recommended bolt torque limits.

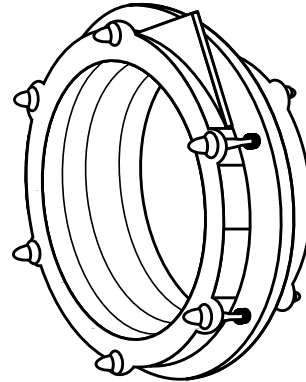

**Figure 4–16** Dual bolt mechanical coupling

### Mechanical Steel Couplings

(Viking Johnson, Helden, Klamflex, etc. see **Figure 4–16**)

Mechanical couplings have been used successfully to join pipes of different materials and diameters, and to adapt to flange outlets. There is a wide variation in the design of these couplings, including bolt size, number of bolts and gasket design. Large variations also exist in the diameter tolerance of other materials, which often results in higher bolt torque than necessary in order to achieve a tight seal on the Flowtite side.

Consequently, we cannot recommend the general use of mechanical couplings with Flowtite pipe. If a mechanical coupling is used to join Flowtite to another pipe material then only mechanical couplings with a dual independent bolting system should be used (**Figure 4–16**). This allows for the independent tightening of the Flowtite side, which typically requires less torque than recommended by the coupling manufacturer.

It is advised that the local Flowtite pipe supplier be consulted when mechanical couplings are contemplated for use on a project. Be prepared to present information on the specific design (brand and model). The pipe supplier can then advise under what conditions, if any, this design might be suitable for use with Flowtite.

### Corrosion Protection

Regardless of the corrosion protection applied to the steel mantle, the balance of the coupling needs to be corrosion protected as well. For details please consult your local supplier.

## GRP Adapters

The Flowtite coupling can be used to join Flowtite pipe to other pipe materials with the same outside diameter (**Table 6-1**) for non-pressure applications. For pressure applications consult the manufacturer.

Custom designed GRP adaptors or stepped couplings can be made to connect GRP pipe with other pipe materials or different diameters. Please consult the manufacturer.

## 5 Thrust Restraints, Concrete Encasement and Connections to Rigid Structures

When the pipeline is pressurized, unbalanced thrust forces occur at bends, reducers, tees, wyes, bulkheads and other changes in line direction. These forces must be restrained in some manner to prevent joint separation. Usually this is most economically accomplished by use of thrust blocks, or alternatively, by direct bearing and friction between pipe and soil.

Direct transfer of thrust through friction and bearing are accomplished by using restraint joints and special pipes that transfer axial thrust. The accompanying fittings are designed for direct bury. A friction factor of 0.5 between Flowtite pipe and non-cohesive soils may be considered when determining the required anchor length of the pipe connecting to the fittings.

Determination of need and design, as well as the level of steel reinforcement of concrete structures, is the responsibility of the owner's engineer. Flowtite fittings are designed to withstand the full internal pressure, while the concrete structure shall support its shape and transfer the load. As the expansion of the pressurized fittings is typically greater than the tensile strength that the concrete would carry, steel reinforcement to control crack widths should be considered.

### Thrust Blocks

Thrust blocks must limit the displacement of the fitting relative to the adjacent pipe to preserve the leak tightness of the Flowtite coupling joint. The resulting angular deflection shall be less than the values indicated in **Table 4-1**.

For more details of pipe installation and system layout see clauses 5.1 and 5.2 .

For operating pressures above 10 bar (PN>10) the block must completely surround the fitting. For lower pressures special fittings can be supplied that allow for partial embedding. The block should be placed either against undisturbed earth or backfilled with pipe zone materials selected and compacted as appropriate to meet the original native soil's strength and stiffness. Thrust blocks are required for the following fittings when the line pressure exceeds 1 bar (100 kPa):

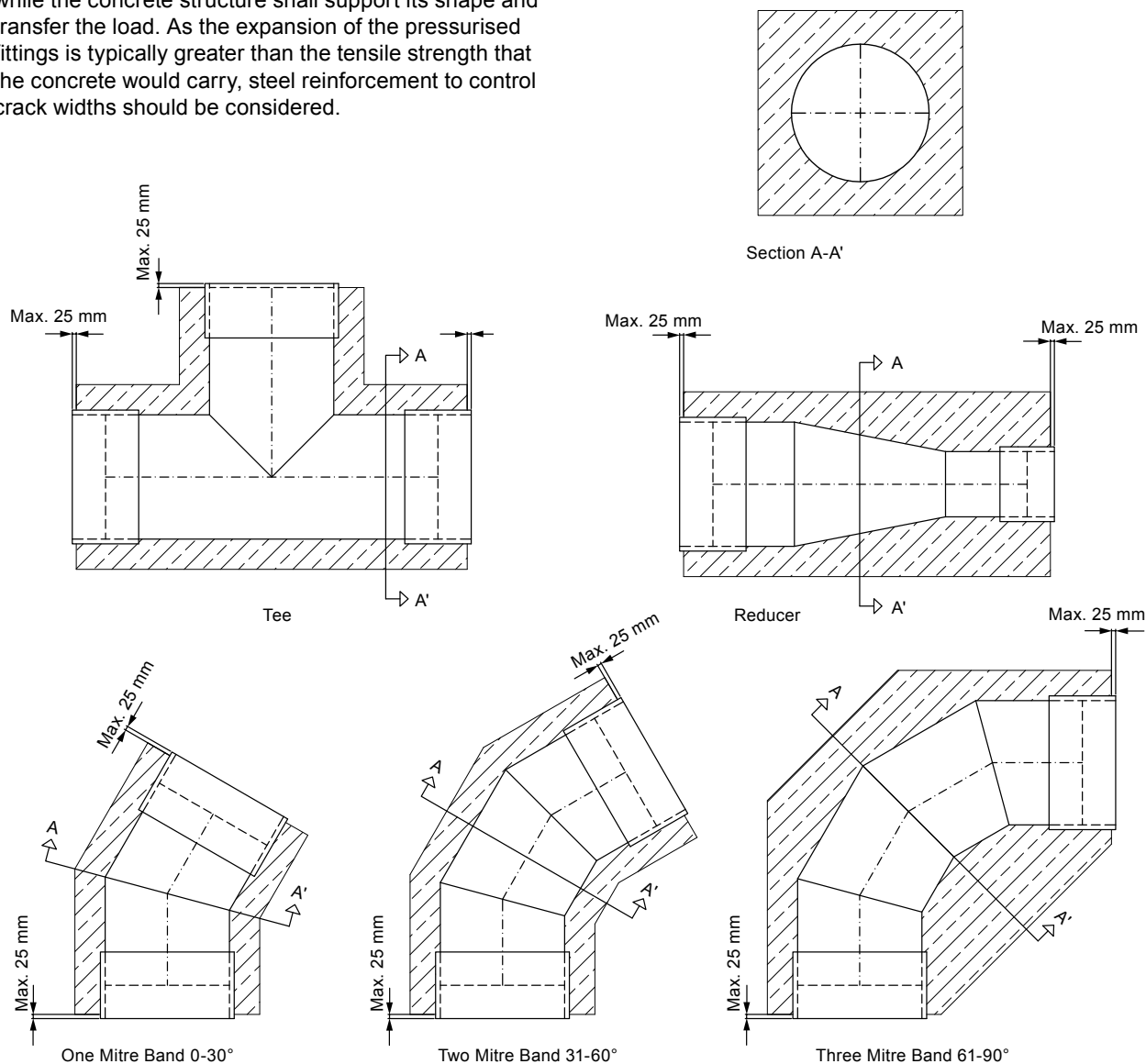

Figure 5-1 Thrust blocks

- 1** All bends, reducers, bulkheads and blind flanges.
- 2** Tees, when the branch pipe is concentric to the header pipe centreline.

Concentric manways (blind flange tees), drains and air vents, which do not generate unbalanced thrust in operation, do not require encasement, but do require thrust resistant branches and fittings.

**!** **Note:** The thrust block shapes shown are merely illustrative. The exact shape will be dependent on design and project requirement (see **Figure 5-1**).

### Valves

Valves must be sufficiently anchored to absorb the pressure thrust. More details on valves and chambers are provided in **section 8**

### Nozzles

Nozzles are tee branches meeting all of the following criteria:

- 1** Nozzle diameter ≤ 300mm.
- 2** Header diameter ≥ 3 times nozzle diameter.

**!** **Note:** it is not necessary to encase nozzle connections in concrete.

## 5.1 Concrete Encasement

When pipes (or fittings) must be encased in concrete, such as for thrust blocks, stress blocks, or to carry unusual loads, specific additions to the installation procedures must be observed.

DN	Maximum Strap Spacing (m)
< 200	1.5
200 – 400	2.5
500 – 600	4.0
700 – 900	5.0
≥ 1000	6.0

**Table 5–2 Maximum strap spacing**

### Pipe Anchoring

During the pouring of the concrete, the empty pipe or fitting will experience large uplift (flotation) forces. The pipe must be restrained against movement that could be caused by these buoyancy forces. This is normally accomplished by strapping over the pipe to a base slab or other anchor(s). Straps should be a flat material of minimum width 8% of DN or 25 mm (whichever is larger), strong enough to withstand flotation uplift forces, with a minimum of two straps per pipe and with the maximum spacing between straps as shown in **Table 5–2**. For PN1 pipes the maximum strap spacing shall be reduced by 33%. The straps should be tightened to prevent pipe uplift and -movement, but not so tight that additional pipe deflection is caused (see **Figure 5–2**). Tees and elbows require at least a 3 strap fixing. To prevent lateral movement, a cross strapping is recommended. Pipes should also be strapped adjacent to joints to avoid misalignment.

### Pipe Support

The pipe should be supported in such a way that the concrete can easily flow completely around and fully underneath the pipe. Also, the supports should result in an acceptable pipe shape (less than 3% deflection and no bulges or flat areas). For pressure pipes the deflection should be limited to less than 1% to avoid high loads on the surrounding concrete due to pressure re-rounding of the pipe. It is recommended to support internally all pipes larger than DN1500 during concrete encasement. The internal supports shall have large shaped contact surfaces to avoid stress concentrations in the pipe and should be collocated with the anchoring straps, see **Figure 5-1.2**.

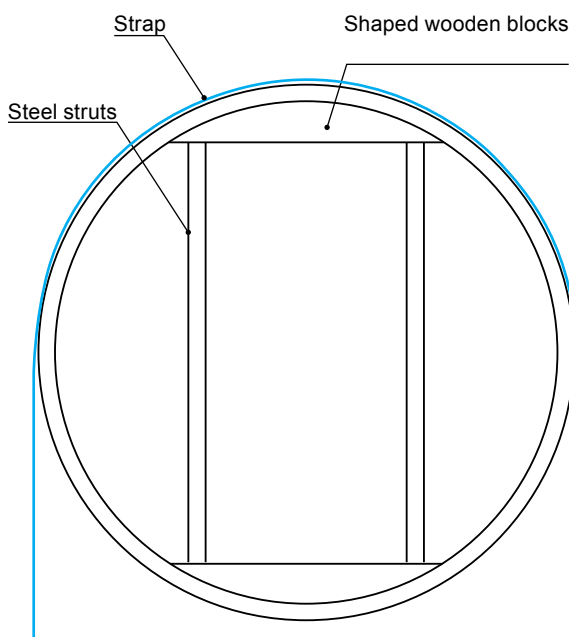
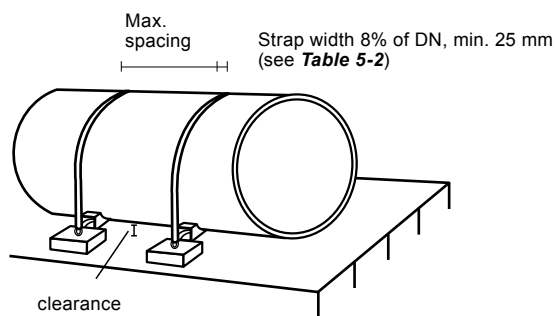

**Figure 5-1.2 Internal pipe support**

## Concrete Pouring

The concrete must be placed in stages allowing sufficient time between layers for the cement to set and no longer exert buoyant forces. The maximum lift heights, as a function of stiffness class, are as shown in **Table 5–3**.

Maximum lift is the maximum depth of concrete that can be poured at one time for a given nominal stiffness class.



**Figure 5–2 Pipe anchoring – Maximum spacing of straps.** See table **Table 5–2**

**Note:** The need for anchoring and supporting of the pipes during the concrete pouring can be reduced by actively controlling and limiting the buoyancy exerted on the pipes.

SN Maximum lift	DN Maximum Spacing (m)
2500	Larger of 0.3 m or DN/4
5000	Larger of 0.45 m or DN/3
10000	Larger of 0.6 m or DN/2

**Table 5–3 Maximum concrete pour lifts**

## 5.2 Connections to Rigid Structures

Excessive bending and shear stresses can develop in a pipe that moves excessively in relation to a rigid structure. This may occur when a pipe passes through a wall (e.g. valve chamber or manhole), is encased in concrete (e.g. thrust block), or is flanged to a pump, valve or other structure.

For all connections to rigid structures, action must be taken by the installer to minimize the development of high discontinuity stresses in the pipe. Angular deflection and misalignment at joints close to thrust blocks shall be avoided during installation. Two options are available. The standard (preferred) method uses a coupling joint cast into the concrete-pipe interface. The alternate wraps the pipe in rubber to ease the transition.

### Standard

Cast a coupling joint in the concrete at the interface (**Figure 5-3**) so that the first pipe outside the concrete has complete freedom of movement (within the limits of the joint). For PN larger than 16 this standard method should be used, and the length of the short section pipe kept at the maximum indicated in **Figure 5-3**.

- !** **Caution:** When casting a coupling in concrete be sure to maintain its roundness so later joint assembly may be accomplished easily. Alternatively, make up the joint prior to pouring the concrete.
- !** **Caution:** Since the coupling cast in concrete is rigid, it is very important to minimize the vertical deflection and deformation of the adjacent pipe.
- !** **Caution:** It is recommended to connect the rocker pipe first before concrete encasement. If this is not possible, care must be taken that the coupling is kept in round shape.

### Alternate

Where the standard method is not possible, wrap (**Figure 5-4**) a band (or bands) of rubber (**Figure 5-5** and **Table 5-4**) around the pipe prior to placement of any concrete such that the rubber slightly protrudes (25 mm) from the concrete. Lay out the pipeline so the first completely exposed coupling joint is located as shown in **Figure 5-4**. For PN larger than 16 this alternate method is not recommended.

### Construction Guidelines

- 1** When the design of the concrete structure is considered, it should be noted that any excessive settlement of the structure relative to the pipe can be the cause of a pipe failure.
- 2** It has been found that including a short length (rocker pipe) near the rigid connection is a good way to accommodate differential settlement (see **Figure 5-3** and **Figure 5-4**). The minimum length of the short length should be the larger of one DN or 1 metre, and the maximum length - the larger of two DN or 2 metres. For small diameter pipe (DN < 300 mm) the length of the short piece is 500 mm. This rocker pipe section is used to account for some differential settlements that may occur. The rocker pipe should have straight alignment with the concrete structure at the time of installation to provide maximum flexibility for subsequent movements. Multiple short lengths or rocker pipes should not be used, as the short spacing between couplings may result in an unstable condition. Misalignment problems should be remedied by re-bedding the full pipe sections leading to the rocker pipe.

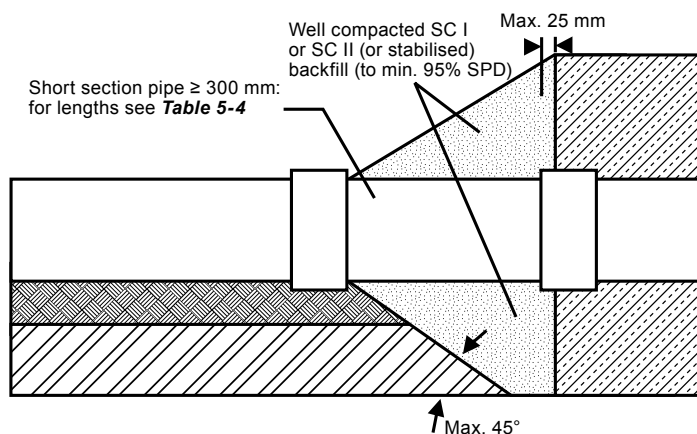

**Figure 5-3 Standard connection – coupling cast in concrete**

DN	BL [mm]*	BL <sub>min</sub> [mm]	BL <sub>max</sub> [mm]
100	500	500	1000
150	500	500	1000
200	500	500	1000
250	500	500	1000
300	500	500	1000
350	500	500	1000
400	500	500	1000
450	500	500	1000
500	1000	1000	1000
600	1000	1000	1200
700	1000	1000	1400
800	1000	1000	1600
900	1000	1000	1800
1000	2000	1000	2000
1100	2000	1100	2200
1200	2000	1200	2400
1300	2000	1300	2600
1400	2000	1400	2800
1500	3000	1500	3000
1600	3000	1600	3200
1700	3000	1700	3400
1800	3000	1800	3600
2000	3000	2000	4000
2200	3000	2200	4400
2400	3000	2400	4800
2600	3000	2600	5200
2800	3000	2800	5600
3000	3000	3000	6000
3200	3200	3200	6400
3400	3400	3400	6800
3600	3600	3600	7200
3800	3800	3800	7600
4000	4000	4000	8000

\* recommended length, standard rocker pipe length

**Table 5-4 Rocker pipe length**

- Care must be taken to replace and properly compact backfill adjacent to the concrete structure. Construction of the concrete structure will frequently require over-excavation for formwork, etc. This extra excavated material must be restored to a density level compatible with surroundings to prevent excess deformation, or joint rotation adjacent to the structure. Class SC I or SC II backfill, compacted to 95% Standard Proctor Density, should be brought up to 60% of the pipe's diameter at the interface with the rigid structure (see **Figure 5-3** and **Figure 5-4**) and gradually tapered back. Stabilised backfill (cement) may also be used for this purpose.

### Rubber Wrap Placement

- Position as shown in **Figures 5-4** and **5-5**.
- Tape all seams and edges to assure no cement can get between the rubber and the pipe or between the rubber wraps.

#### Type A:

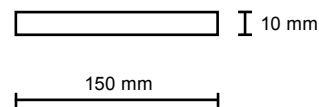

#### Type B:

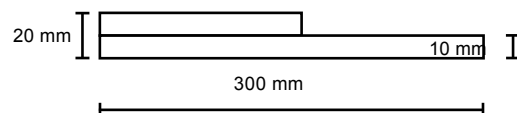

Type A: diameter < DN 700; Type B: diameter ≥ DN 700

**Figure 5-5 Rubber wrap configuration – rubber shall have 50-60 Shore A hardness**

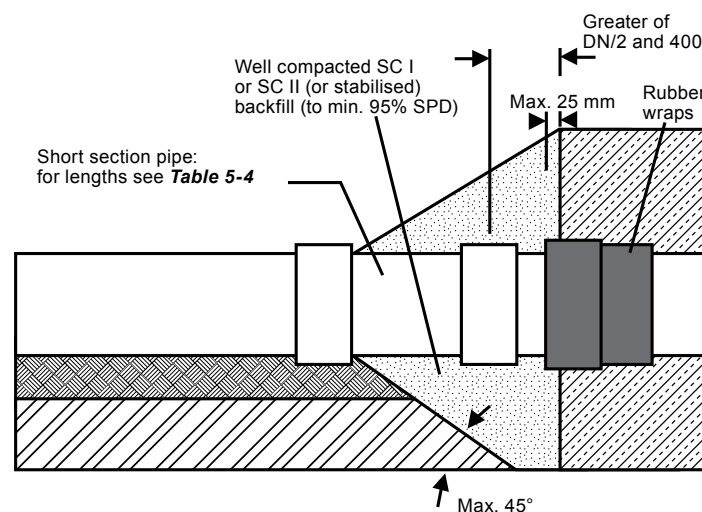

**Figure 5-4 Alternate connection – rubber wrap encased in concrete**



## 5.3 Casings (Tunnels)

When Flowtite standard pipe (unequal exterior flush) is installed in a casing, the following precautions should be observed.

- 1** Pipes may be placed into the casing by pulling (drawing) or pushing (jacking). Please consult the supplier for the calculation of the maximum insertion length/force.
- 2** For an easy insertion, and for protection from sliding damage, the pipes should be equipped with plastic spacers, steel sleeves or wooden skids (as shown in **Figures 5-6 and 5-7**). These must provide sufficient height to permit clearance between the coupling joints and the casing wall.
- 3** Installation into the casing is made considerably easier by using lubricant between the skids and the casing wall. Do not use a petroleum based lubricant as it may cause harm to some gaskets.
- 4** The annular space between the casing and pipe may be filled with sand, gravel or cement grout. Care must be taken not to overstress or collapse the pipe during this step, particularly when grouting. Maximum grouting pressure is given in **Table 5-5**.

SN	Maximum Grout Pressure (bar)
2500	0.35
5000	0.70
10000	1.35

**Table 5-5 Maximum grouting pressure (pipe invert) without internal supports**

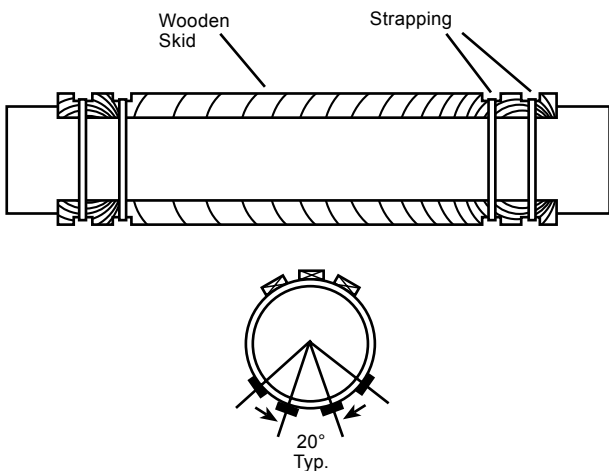

**Figure 5-6 Typical skid arrangement**

**Note:** Do not wedge or brace the pipe in a manner that causes concentrated or point loads on the pipe. Consult the supplier prior to this step for advice on suitability of the chosen method.

**Note:** Adequate attention must be given to the pipe's stiffness and installation procedure if the annular space is not grouted and the pipe is to be subjected to negative pressure. Consult your supplier for advice on how to accommodate such forces.

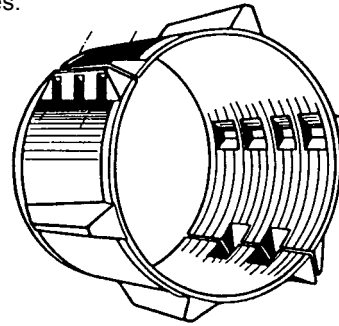

**Figure 5-7 Plastic spacer unit**

Where required or specified, pipe systems using flush joints can be used (See **Figure 5-8**).

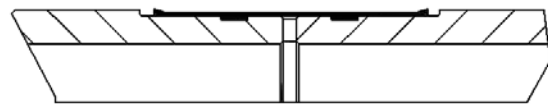

**Figure 5-8 Flush joint**

## 5.4 Concrete Wall Sealings

When a pipe must pass through a concrete wall and water tightness is required, a water tight sealing is necessary to ensure continuous leak tightness of the system.

The connection systems are divided into two categories:

- 1** Made in situ
- 2** Precast

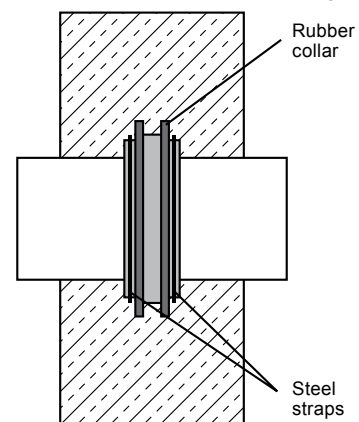

**Figure 5-9 Sample of a rubber collar**

Misc. standard systems are available in the market. Please contact your local supplier.

For connecting a pipeline, please follow the instructions in **section 5.2**.

# 6 Field Adjustments

01  
02  
03  
04  
05  
**06**  
07  
08  
09  
10  
app.

## 6.1 Length Adjustment

A large majority of pipes supplied by Flowtite producers have the outside diameter of the barrel of the pipe within the tolerance range of the calibrated spigot. These pipes are marked as Adjustment Pipe or similar. The following procedures will assist in correctly making the length adjustment:

- 1** Determine the length required and mark a square cut on the selected pipe.
- 2** Cut the pipe at the appropriate location using a circular saw with a diamond-coated blade. Use proper eye, ear and dust protection. Use health & safety protection acc. to your local country regulations.
- 3** Clean the surface in the jointing area, sand smooth any rough spots, using a grinder bevel, grind the pipe end to ease assembly (see **Figure 6-1**). No further grinding is necessary.

Diameter series	DN (mm)	Spigot width (mm)	L (mm)
B2	100	110	3
B2	150	110	4
B2	200	110	4
B2	250	110	6
B2	300	130	6
B2	350	130	8
B2	400	130	10
B2	500	130	14
B1	600	160	17
B1	700 - 2400	160	20
B1	2500 - 3000	175	20
B1	3100 - 4000	185	20

**Table 6-1 Spigot dimensions and tolerances up to PN16**

Other tolerances for higher pressure classes available on request. For intermediate diameters please contact **your local supplier**.

- !** **Note:** Series B2 matches with Ductile Iron spigot O.D. Series B1 is GRP O.D. series. In some countries the Ductile Iron (B2) series may not be used.

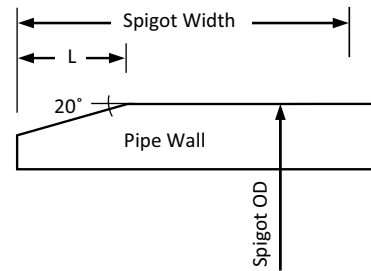

**Figure 6-1 Pipe spigot and bevel dimensions definition for coupling joints**

- !** **Note:** For field closure section, double the spigot width.

The design of the pipes does not require any sealing of the spigot ends after field cutting. However, be sure to comply with local / national norms and regulations regarding sealing, eg adherence to industrial health and safety standards.

- !** **Note:** In relation to this it is of great importance that the interior edge of an adjustment pipe is rounded after field cutting. Specific cutting and chamfering equipment is available on request. Please contact your local dealer.

## 6.2 Field Closures with Flowtite Couplings

Flowtite couplings can be used for field closures and repairs. The minimum length of the closure pipe should be 1 metre. In addition, the closure pipe should not be adjacent to a "rocker" pipe, i.e., the short length meant to provide flexibility adjacent to rigid connections (see **Figure 5-4** →).

### Procedure

Measure the distance between the pipe ends where you want to set in the closure pipe. The closure pipe should be 10-20 mm shorter than the measured length. The narrower the gap the easier it will be to make the closure.

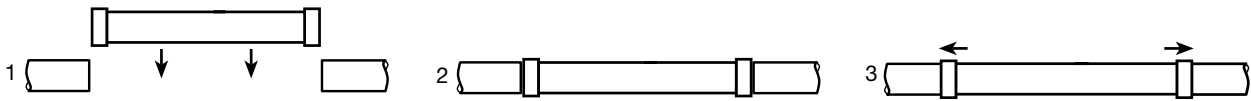

Figure 6-2 Closure section assembly

### Pipe Selection

Choose a pipe which is within the spigot diameter tolerance. These pipes will have the required spigot outside dimension for joining along the entire pipe length. If possible choose a pipe with the outside dimension at the low end of the spigot range (see **Table 6-1**).

### Pipe Preparation

Mark the pipe length required and make a cut perpendicular and square to the pipe axis with a circular saw. Use a grinding tool to make a 20 degree bevel on the pipe end and round-off the corners. Be careful that the remaining thickness on the pipe spigot end is not less than one half the pipe thickness. It is also important to have a minimum chamfer length, L, for guiding the pipe end without damaging the gasket. Follow the recommended lengths in **Table 6-1**. After bevelling, use sandpaper to remove any sharp corners on the pipe surface which may have been caused by the cutting. Smooth the spigot of any rough spots.

**1** **Note:** The spigot width must be at least equal to the coupling width. This will be twice the values shown in **Table 6-1**.

Please make sure that the surface has no grooves, and that the spigot OD is within the limits shown in **Table 6-1**.

### Installation

Description below is just a brief summary. Installation information is extensively described in **section 4.1**.

**1** Select two couplings, remove the centre registers, and leave the gaskets in place. Clean the couplings if necessary. The gasket groove must be free of dirt to allow unrestricted deformation of the gasket.

**2** Lubricate carefully, including between the lips.

**3** Also lubricate the clean spigot ends of the closure pipes with a thin continuous layer of lubricant. Do not forget the bevelled surfaces.

**4** Place one coupling square onto the end of the closure pipe so that the gasket is in contact around its entire circumference. Push or pull the coupling uniformly onto the closure pipe until the entire coupling is resting on the spigot end. It may be necessary to gently help the second ring over the chamfered end of the pipes. Repeat with the second coupling on the other end.

**5** Mark home-lines onto the adjacent pipe spigot ends to control the uniform backward movement of the coupling. The home-line's location is calculated as follows:

$$HL = (Wc - Wg) / 2$$

HL – homeline

Wc – width of the coupling

Wg – width of gap between closure pipe and adjacent pipe (measured).

**6** Set the closure pipe in the trench aligned with the adjacent pipes and with equal clearance on either side. Any angle or tilt will complicate the assembling process.

**7** Clean the spigot ends of the adjacent pipes and lubricate with an even, thin layer. Install special tools to pull the coupling back to closing position (consult your supplier for information about the tools). It is recommended that you pull the couplings over both sides simultaneously, keep the closure pipe centred and minimize pipe end contact. Stop pulling when the coupling's edge touches the home-line. For man-entry size pipes, an individual inside the pipe watching the assembly process can be advantageous.

**8** The compaction of the backfill around a field closure pipe is very important and should be no less than 90% SPD. Often the closure area is over excavated for ease of access. This is recommended to prevent excessive movement and joint rotations.

**1** **Note:** After the coupling is in final position, a feeler gauge may be used to assure that gasket lips are properly oriented.

**1** **Note:** For proper installation specific installation tools might be required!

## 6.3 Field Closures with Non-Flowtite Couplings

Follow the general procedures of **section 6.2** **→** except that the closure pipe will not typically need to have the special long machined spigot ends. The installation procedures for the particular coupling used must be followed (see **section 4.5** **→**).

# 7 Other Installation Procedures and Considerations

## 7.1 Multiple Pipes in Same Trench

When two or more pipes are installed parallel in the same trench, clear spacing between the pipes should be as shown in **Figure 7-1**. Space between the pipe and the trench wall should be as shown in **Figure 3-1**.

It is advisable when laying pipes of different diameters in the same trench to lay them with the same invert elevation. When this is not possible, use backfill material class SC I or SC II to fill all the space from the trench bottom to the invert of the higher pipe. Proper compaction must be achieved (min. 90% SPD).

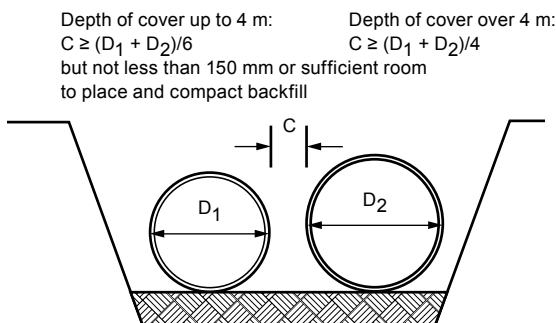

**Figure 7-1 Spacing between pipes in the same trench**

## 7.2 Cross-Overs

When two pipes cross, so that one passes over the other, vertical spacing between pipes and installation of the bottom pipe should be as shown in **Figure 7-2**.

In some cases, it is necessary to lay a pipe under an existing line. Extra care should be taken not to damage the existing pipe. It should be protected by fastening it to a steel beam crossing the trench. It is also advisable to wrap the pipe in order to protect it from impact damage. When the new pipe is laid, backfill material class SC I or SC II must be placed back into the trench and compacted to a minimum of 90% SPD completely around both pipes, plus 300 mm above the crown of the upper pipe. This backfill should extend at least twice the diameter into each trench (see **Figure 7-3**).

Depth of cover up to 4 metres  
 $f \geq \frac{D_1 + D_2}{6}$

Over 4 metres  
 $f \geq \frac{D_1 + D_2}{4}$

but not less than 150 mm

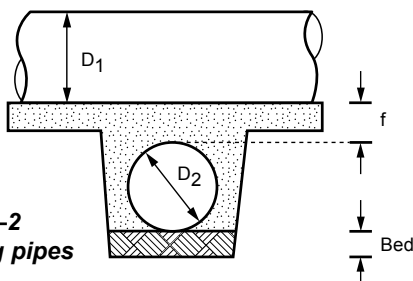

**Figure 7-2 Crossing pipes**

Use only Type A or Type B backfill materials compacted to a minimum of 90% Relative Compaction

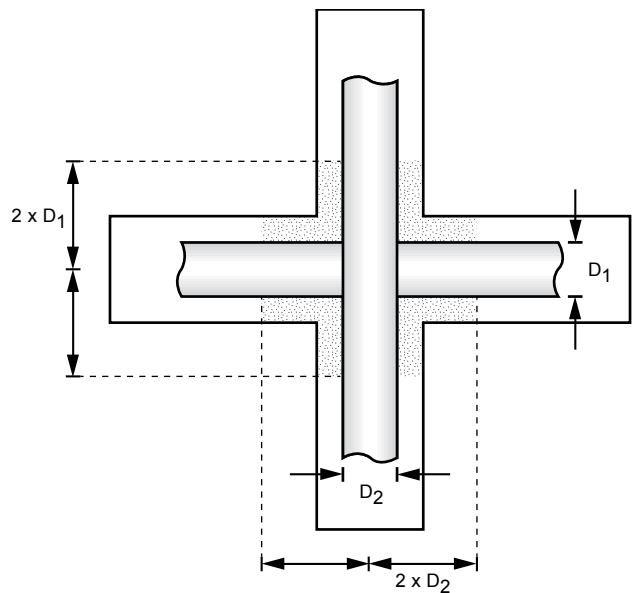

**Figure 7-3 Top view of backfill in cross-over.**

## 7.3 Unstable Trench Bottom

Where the trench bottom has soft, loose or highly expansive soils, it is regarded as unstable. An unstable trench bottom must be stabilised before laying a pipe, or a foundation must be constructed to minimize differential settlement of the trench bottom to prevent joint rotation or misalignment. A well graded sandy gravel compacted to 90% SPD or crushed stone is recommended for use in foundation layers.

The depth of the sandy gravel or crushed stone material used for foundation depends upon the severity of the trench bottom soil conditions, but should not be less than 150 mm. The normal bedding must be placed on top of such foundations. When crushed rock is used, the use of filter cloth to completely surround the foundation material will prevent foundation and bedding materials from migrating into one another, which could cause loss of pipe bottom support. Filter cloth is not needed if the same material is used for foundation and bed, or if graded sandy gravel is used for the foundation. Additionally, the maximum pipe section length between flexible joints should be less than 12 m.

01
02
03
04
05
06
07
08
09
10
app.

## 7.4 Flooded Trench

When the groundwater table is above the trench bottom, the water level must be lowered to at least the trench bottom (preferably about 200 mm below) prior to preparation of the bed. Different techniques may be used depending on the nature of the native material. For sandy or silty soils, a system of well-points to a header pipe and a pump is recommended. The spacing between individual well-points and the depth at which they will be driven depends on the groundwater table and the permeability of the soil. It is important to use a filter around the suction point (coarse sand or gravel) to prevent clogging of the well-points by fine grained native material.

When the native material consists of clay or bedrock, well-points will not work. Dewatering is more difficult to achieve in this case. The use of sumps and pumps is recommended.

If the water cannot be maintained below the top of the bedding, sub-drains must be provided. The sub-drains should be made using single size aggregate (20 - 25 mm) totally embedded in filter cloth. The depth of the sub-drain under the bed depends on the amount of water in the trench. If the groundwater can still not be maintained below the bed, filter cloth should be used to surround the bed (and if necessary the pipe zone area as well) to prevent it from being contaminated by the native material. Gravel or crushed stone should be used for bed and backfill. The following cautions should be noted when dewatering:

- Avoid pumping long distances through the backfill materials or native soils, since the loss of support to previously installed pipes due to removal of materials or migration of soil may occur.
- Do not turn off the dewatering system until sufficient cover depth has been reached to prevent pipe flotation.

## 7.5 Use of Trench Supports

Care must be taken to ensure proper support between native soil and backfill when sheeting is removed. Removing the sheeting in steps and then compacting the pipe-zone backfill against the trench wall will provide the best support to the pipe, thus filling the voids that frequently occur behind sheet piling. If the sheeting is pulled after the pipe-zone backfill has been placed, the backfill loses support which in turn reduces the support to the pipe, especially when voids form behind the sheeting. To minimize this loss of support the sheeting should be vibrated during removal. Make sure that there are no voids or lack of backfill

between the outside of the sheeting and the native soil up to at least 1 m above the pipe crown. Use only backfill class SC I or SC II between the temporary sheeting and the native soil, compacted to at least 90% SPD.

For permanent sheeting, use sheeting of sufficient length to properly distribute the pipes' lateral loads at least 300 mm above the pipe crown. The quality of the permanent sheeting should be such that it lasts for the design life of the pipe.

Backfill procedures are the same as for standard installations. Permanent sheeting can be assumed to be a group 1 native soil.

## 7.6 Trench Construction in Rock

Minimum dimensions for pipe installations in a rock trench should be as in **section 3.1** →. Where the rock ends and the pipe passes into a soil trench area (or reverse), create a smooth transition and flexible joints should be used as shown in **Figure 7-4**.

Alternatively, use of cement stabilised backfill (see **section 10.2**) for the foundation and bedding of a pipe just passing through a rock-soil transition would negate the need to locate a flexible joint at this transition. Trench construction should be according to the method applicable for the native soil condition.

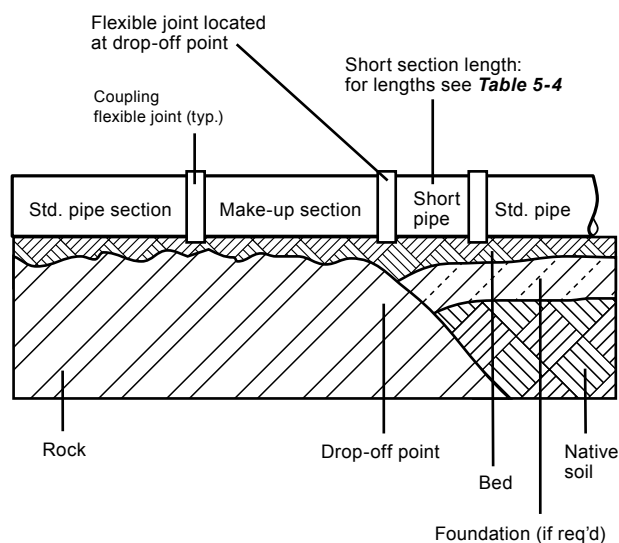

**Figure 7-4 Method of trench construction and pipe layout at rock-soil trench transition or at abrupt changes in bedding conditions.**

## 7.7 Inadvertent Over-Excavation

Any inadvertent over-excavation of the trench walls or the trench bottom in the foundation, bed or pipe zone areas should be filled with backfill material compacted to a least 90% relative compaction.

- Stability of individual pipes is monitored throughout the construction phase and the first phases of operation. This can be done by controlling the gap between pipe spigots.
- A special pipe design may be required, consult the pipe supplier.

## 7.8 Installation of Pipes on Slopes

### General

- The angle at which slopes can become unstable depends on the quality of the soil. The risk of unstable conditions increases dramatically with slope angle.
- In general, pipes should not be installed on slopes greater than 15 degrees, or in areas where slope instability is suspected, unless supporting conditions have been verified by a proper geotechnical investigation.

### Buried Installation Parallel to Hillside

Before pipes are installed underground on slopes greater than 15 degrees, it is recommended that a geotechnical engineer be consulted. Flowtite pipes may be installed on slopes greater than 15 degrees provided the following minimum conditions are achieved:

- Long-term stability of the installation can be ensured with a proper geo-technical design.
- For slopes over 15 degrees, use either SC 1 or cement-stabilised backfill in the pipe zone as backfill material.
- Installation should always proceed from the low point and progress up the slope. Each pipe should be properly backfilled to grade before the next pipe is placed in the trench.
- The surface over the completed pipe trench must be protected against erosion from flowing water.
- Pipes are installed in straight alignment (plus or minus 0.2 degrees) with a minimum gap between pipe spigots.
- Absolute long-term movement of the backfill in the axial direction of the pipe must be less than 20 mm.
- The installation must be properly drained to avoid washout of materials and thus ensure adequate soil shear strength.

### Perpendicular to hillside

When pipes are installed perpendicular to the fall line of a steep slope, consultation with a geotechnical engineer is recommended when the slope angle exceeds 15 degrees to assure that the hillside remains stable.

The surface of the completed trench must be re-contoured to eliminate depressions and preclude the formation of puddles of water. The collection of water on a slope reduces slope stability and may contribute to internal slide and shear conditions.

### Aboveground Installation

- The preferred method of installing pipes on steep slopes is above ground as above ground structures such as pipe supports are more easily defined, the quality of installation is easier to monitor and settlement easier to detect.
- See above ground installation brochure for more information [→](#).

# 8 Accommodating Valves and Chambers

- 01
- 02
- 03
- 04
- 05
- 06
- 07
- 08
- 09
- 10
- app.

For practical purposes the positioning of in-line valves along most pressurised pipelines is necessary. Isolating a portion of the supply or distribution system, air and vacuum relief valves at high points for the controlled release of accumulated air, or introduction of air to avoid under pressure, drainage or clean-out. All of these different devices can be accommodated with Flowtite pipe. The ultimate responsibility for the design of the piping systems is the professional engineer. However, Flowtite Technology engineers have observed many different methods of incorporating these appurtenances into a pipeline using Flowtite pipe. This section is devoted to offering the design engineer or contractor some guidelines on accommodating valves and chambers in a pressure Flowtite pipeline.

## 8.1 Anchoring In-Line Valves

Flowtite pipe is designed to handle nominal axial loads, but is not designed to accommodate thrust and shear loads that may result from the inclusion of valves in the piping system.

Loads from valves must be externally restrained as required by AWWA C600. Several methods for anchoring valves are described. The best method will be dependent on the specific operating conditions for each system. Generally, the best method is dependent on pipe diameter and operating pressure. There are two basic considerations for in-line valves: directly accessible (installed in chambers) or not accessible (direct buried). Generally, smaller diameter valves are direct buried without the use of concrete chambers for easy access.

### Direct Bury

**Type 1** The lowest cost and easiest installation for a small diameter valve is to direct bury it, encapsulated in its own concrete thrust block (See **Figure 8-1**). This method can be used with larger valves, the only limit being a reasonable thrust block design. The reinforced concrete thrust block must be properly designed to resist thrust from a closed valve with movement limited to the leak tightness of the joint.

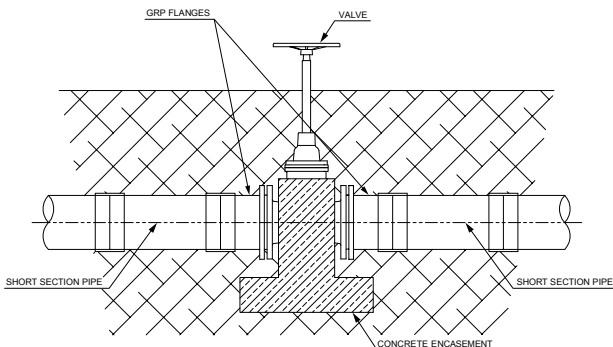
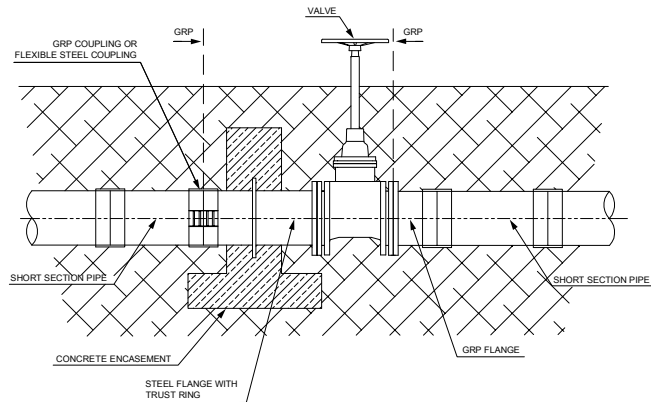

**Figure 8-1 Type 1 – Valve encased in thrust block**

The following guidelines should be observed in designing the Type 1 arrangement:

- 1** The size of the thrust block is based on the local soil stiffness, backfill material and installation conditions. Limit lateral movement to preserve the leak tightness of the joint.
- 2** The flanged stubs should be no more than 1000 mm in length, with a Flowtite coupling on the outside leg connecting the stub to a rocker pipe (**Figure 5-4** →).

**Type 2** The anchoring method here is similar to Type 1 except that the valve body can be accessed (see **Figure 8-2**). While allowing a relatively simple installation, the valve may be available for servicing. The limit of use is dependent on the strength of the stub of steel or ductile iron pipe and the attached anchoring collar. For small thrust loads, only one side of the valve needs to be anchored.



**Figure 8-2 Type 2 – Thrust block adjacent to valve**

The following guidelines should be observed in designing the Type 2 arrangement:

- 1** The size of the thrust block is based on the local soil stiffness, backfill material and installation conditions. Limit lateral movement to preserve the leak tightness of the joint.
- 2** The flanged stubs should be no more than 1000 mm in length. The stub, with the flange or anchor collar, connects to the Flowtite rocker pipe with the standard Flowtite coupling.
- 3** If steel or ductile iron stubs are used, the use of flexible steel couplings or transition (dual bolting) mechanical couplings is recommended.

## Chambers

**Type 3** This method can be used for all but the larger, higher pressure valves. The limit of use is dependent on the ability to place the structural support system into the valve chamber. The support system must be designed to accept the total axial thrust without over-stressing the valve flanges or the reinforced concrete valve chamber walls. The valve chamber acts as the thrust block and must be designed as such. The thrust restraint is placed on the compression side of the valve to transfer the thrust directly to the chamber wall. The other end of the pipe system is relatively free to move axially allowing for movement due to temperature change and Poisson's effect.

The assumption inherent in **Figure 8-3** is that the thrust acts only in one direction. However, consideration must be given to the possibility of back pressure on a closed valve which could create a thrust load in the opposite direction. To accommodate this possibility the structural support system can be designed to handle load in either direction. The details are left up to the design engineer.

The following guidelines should be observed in designing the Type 3 arrangement:

- 1 Thrust and shear from the valve is to be supported through a steel frame support system.
- 2 The standard Flowtite pipe is to have either a rubber wrap or coupling at the concrete wall penetration to reduce local stresses caused by the constraint of free radial displacement during pressurization.

- 3 The valve chamber must be designed to accept the full axial thrust and vertical weight of the valve. Local reinforcements of the valve chamber foundation and walls will be required to accept the axial forces at the attachment points.
- 4 The valve chamber is to be designed as a thrust block to resist axial thrust. The backfill selection, placement and compaction must be sufficient to resist settlement and lateral forces created by the valve closure. Limit lateral movement to preserve the leak tightness of the joints.
- 5 There must be a rocker pipe placed outside the valve chamber according to standard installation practices. (see **section 5.2**)
- 6 The thrust is taken via compression of the structural support system. No axial load is transmitted to the pipe.
- 7 Use cement stabilised backfill, or gravel compacted to minimum 95% relative compaction, to fill the void beneath the pipe exiting the valve chamber structure (see **Figure 5-3** →).

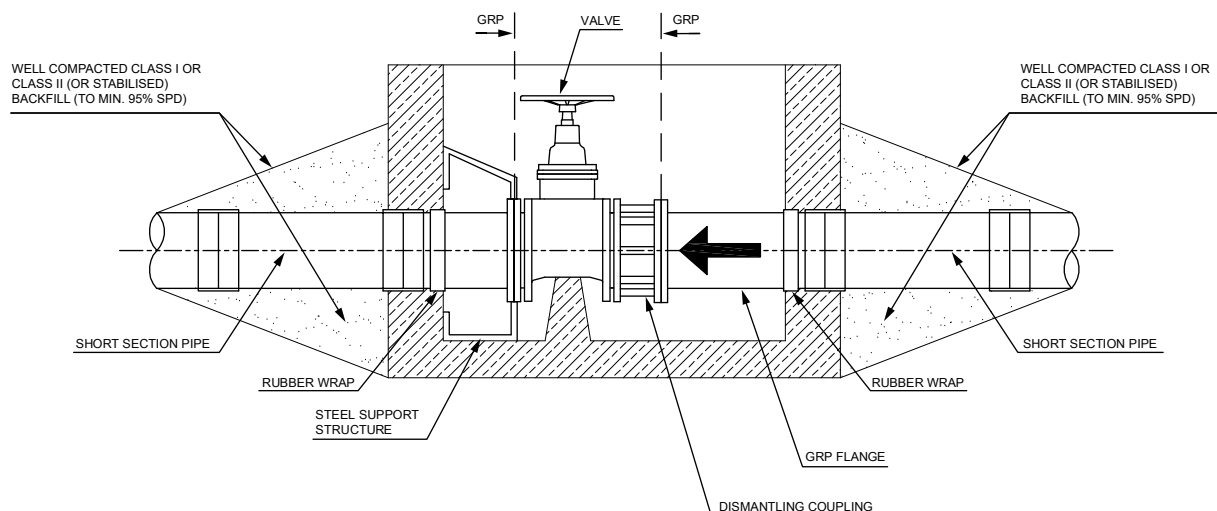

**Figure 8-3** Type 3 – Use of structural support system to accommodate thrust forces



**Type 4** This method (**Figure 8–4**) can be used for anchoring any valve with pressures up to 16 bar. The limitation in use of this method are the practical limits of Flowtite pipe reinforcement and puddle flange length. The puddle flange is placed on the compression side of the valve directly loading the chamber wall which acts as a thrust block. The other side of the pipe system in the chamber is relatively free to move axially to allow movement due to temperature change and Poisson's effect. The following guidelines should be observed in designing the Type 4 arrangement:

- 1** A “special” pipe will have a GRP puddle flange fabricated on the compression-side which is embedded into the valve chamber wall acting as an anchor.
- 2** The other pipe leg is free to move axially through the sealing gasket in the valve chamber wall.
- 3** The weight of the valve is to be supported from the base of the valve chamber, and the valve chamber must be designed to accept the full axial thrust of the valve. A concentration of reinforcement bars will be required to accept the axial forces from the embedded puddle flange.

- 4** The valve chamber is to be designed as a thrust block to resist axial thrust. The backfill selection, placement and compaction must be sufficient to resist settlement and lateral forces created by the valve closure. Limit lateral movement to preserve the leak tightness of the joint.
- 5** The “special” pipe will incorporate a coupling embedded in the valve chamber wall. The “special” pipe within the valve chamber will be reinforced to accept the axial loads and local stresses at the interior face of the concrete chamber. Please advise the Flowtite supplier on the maximum anticipated thrust loads so that the proper reinforcement for the “special” pipe can be designed.
- 6** There must be a rocker pipe placed outside the valve chamber according to standard installation practices (see **section 5-2** →).
- 7** Use cement stabilised backfill, or gravel compacted minimum to 95% relative compaction, to fill the voids under the pipe outside the valve chamber structure (see **Figure 5–3** →).

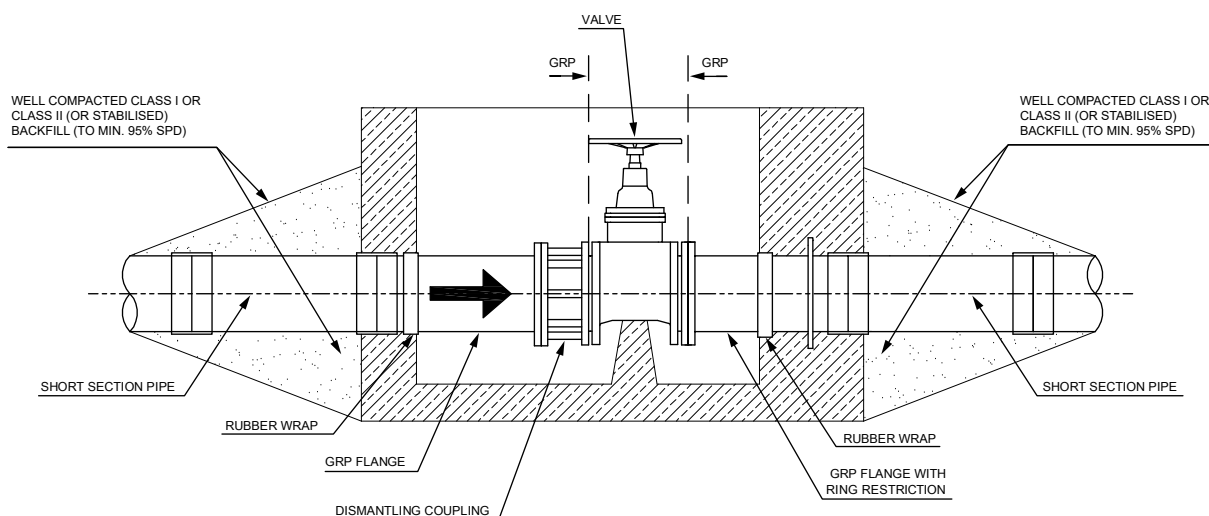

**Figure 8–4 Type 4 – Use of puddle flange to accommodate thrust forces**

**Type 5** This anchoring method (**Figure 8-5**) may be used for any application. The only limitation in use would be the size of the valve chamber. The valve chamber is to be designed as the thrust block. When the dimensions of the required thrust block face are larger than the physical dimensions of the valve chamber, extend the dimensions of the down-stream side of the valve chamber to meet the thrust block requirements. The thrust restraint flange is placed on the compression side of the valve to transfer the thrust directly to the chamber wall, which acts as a thrust block. The other end of the pipe system is relatively free to move axially to allow movement due to temperature change and Poisson's effect.

The following guidelines should be observed in designing the Type 5 arrangement:

- 1 The weight of the valve is to be supported from the base of the valve chamber. The thrust from a closed valve is to be taken by a steel puddle flange anchored into the valve chamber wall by a welded flange on the compression side of the valve.
- 2 A flexible steel coupling or a transition mechanical coupling is to provide transition between the steel pipe stub and a standard Flowtite rocker pipe outside the valve chamber.
- 3 The other pipe leg is free to move axially through the sealing gasket in the valve.
- 4 The size of the thrust block is based on the local soil stiffness, backfill material and installation conditions. Limit lateral movement to preserve the leak tightness of the joint.
- 5 There must be a rocker pipe placed outside the valve chamber according to standard installation practices (see **section 5.2** →).

- 6 Use cement stabilised backfill, or gravel compacted minimum to 95% relative compaction, to fill the void beneath the pipes exiting the valve chamber structure (see **Figure 5-3** →).

## 8.2 Air and Vacuum Valves

It is common practice to locate air or combination air/vacuum relief valves at high points in a long transmission line. The valves should be designed to slowly release any accumulated air in the high point of a line, which might limit or block the flow. Likewise, vacuum relief valves limit the amount of negative pressure a pipeline might experience by opening when under pressure is sensed by the valve. The detail design and sizing of these valves is beyond the scope of this installation guide. However, guidelines are offered here on the general layout of fittings and structures to accommodate these off-line valves. There are basically two ways air/vacuum relief valves can be accommodated in a Flowtite system. The most common method is to mount the valve directly on the vertical flange nozzle. Alternatively, for heavy valves, a tangential nozzle can also be designed to accommodate the assembly. Details for all possible arrangements follow.

### Air/Vacuum Valves

The simplest way to accommodate small air/vacuum valves is to mount the valve directly on top of a vertical flanged nozzle rising from the main below. Typically a concrete chamber houses the valve, providing safe and easy passage of air through the valve assembly. When designing and constructing the valve chamber directly over the pipe, it is important to ensure that the weight of the concrete chamber is not directly transferred to the vertical nozzle, and thus to the Flowtite pipe below.

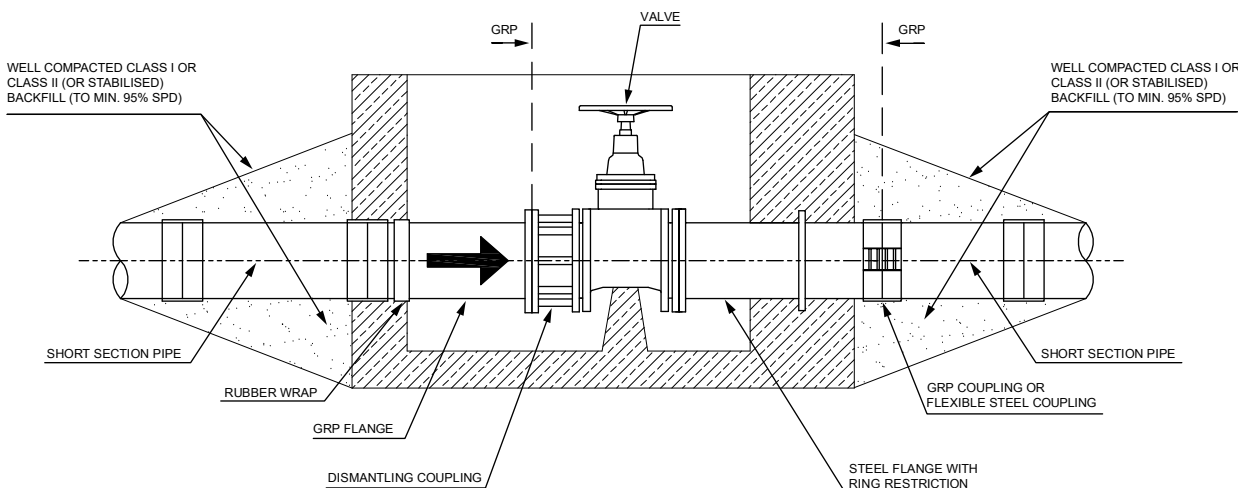
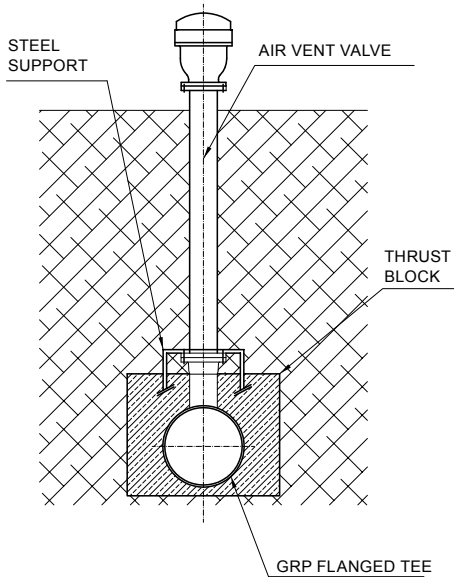
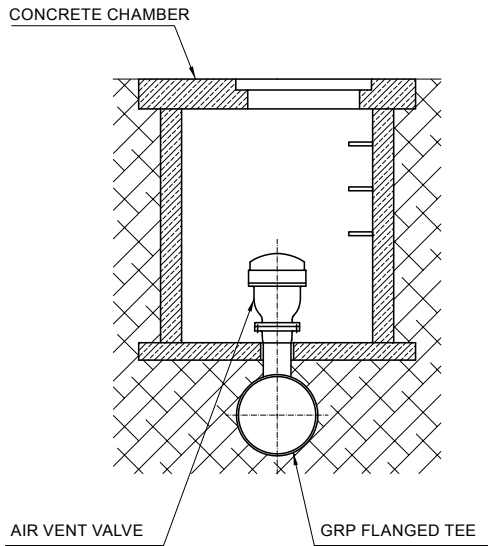

**Figure 8-5 Anchoring**

01
02
03
04
05
06
07
08
09
10
app.

This can be avoided by having the vertical opening in the base of the chamber larger than the outside diameter of the Flowtite riser nozzle.

**Figure 8–6** provides general illustrations of these desirable features.



**Figure 8–6 Accommodating a small diameter air/vacuum valve**

**Large Air/Vacuum Relief Valves (>100mm)**

In the case of larger air/vacuum relief valves, the preferred method of installing these heavier valves is to provide a GRP flanged tee with large branch DN ( $\geq 600$ ), to accommodate the high axial load of the lave. This valve is attached on a steel blind flange connected to the GRP branch.

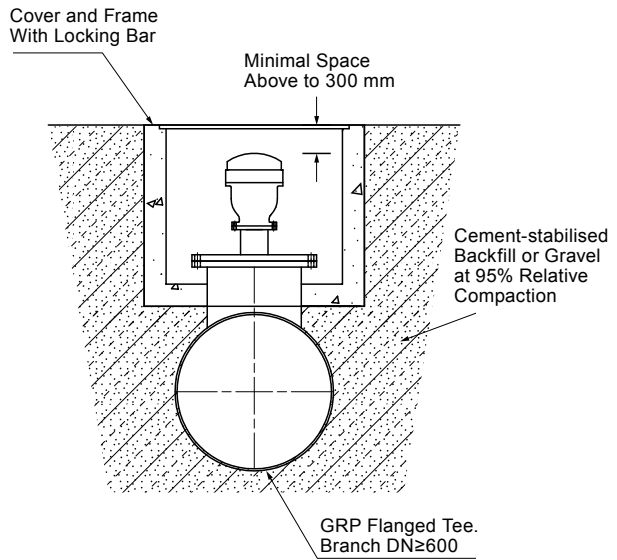

**Figure 8–7 General illustration of a large air/vacuum valve with Flowtite pipe**

Other alternative method is with their weight not directly bearing on the riser, but with a tangential nozzle leading to the valve installed in an adjacent chamber. The tangential nozzle can be parallel to the horizontal axis, or at a slight vertical angle ( $< 22.5$  degrees) with an elbow. Please refer to **section 5**, Thrust Restraints, for guidance on whether a thrust block alone or a combination thrust and stress block would be required. In general, if the tangential branch pipe's diameter (chord length) is more than 50% of the diameter of the header pipe then a thrust/stress block is required. Otherwise, only a thrust block is required.

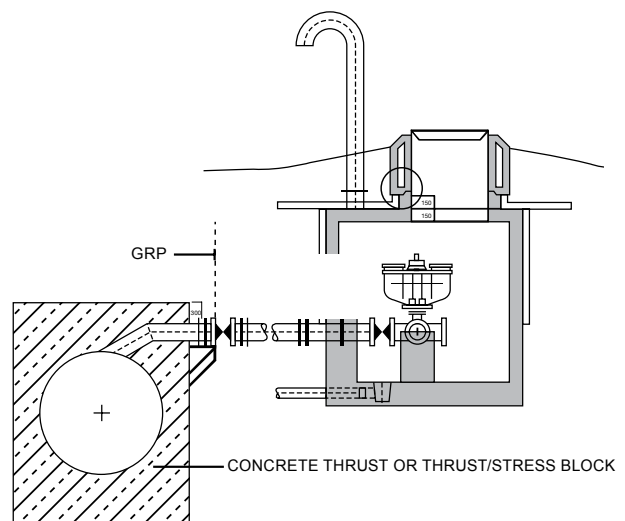

**Figure 8–8 Alternative method to accommodate large air/vacuum valve with Flowtite pipe**

### 8.3 Wash Out – and Scour Valves

Accommodating wash out valves and scour valves is similar to a large diameter air valve, only the branch is tangential to the invert of the pipe. The same rules for thrust and thrust blocks apply. If the tangential branch's pipe diameter (chord length) is more than 50% of the diameter of the header pipe, then a thrust block is required ([section 5](#)). **Figure 8–9** gives some typical arrangements for accommodating these types of appurtenances in a Flowtite pressure pipeline. It's necessary to remark that all valves must be properly supported.

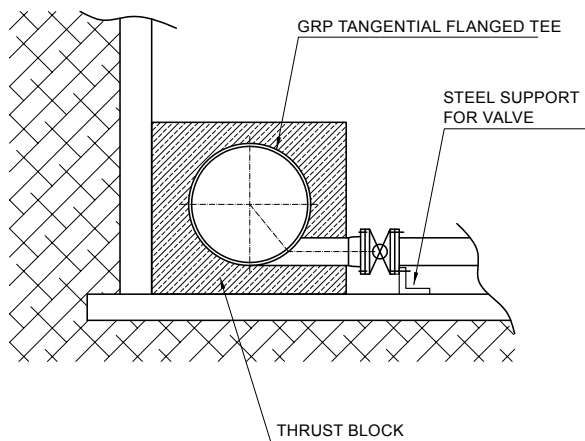

**Figure 8–9 Accommodating wash out– and scour valves**

# 9 Post-Installation

- 01
- 02
- 03
- 04
- 05
- 06
- 07
- 08
- 09
- 10
- app.

## 9.1 Checking the installed Pipe

Requirement: Maximum installed diametrical deflection must not exceed the values in **Table 9-1** initially.

Bulges, flat areas or other abrupt changes of pipe wall curvature are not permitted. Pipes installed outside of these limitations may not perform as intended.

Checking to insure that the initial deflection requirements have been met is easy to do and should be done for each pipe immediately after completion of installation (typically within 24 hours after reaching maximum cover).

The expected initial pipe deflection after backfilling to grade level is less than 2% for most installations. A recommended way to check installation is to compare measured and computed deflections. A value exceeding this amount indicates that the desired quality of the installation has not been achieved and should be improved for the next pipes (i.e. increased pipe zone backfill compaction, coarser grained pipe zone backfill materials or wider trench, etc.).

Deflection measurements in each pipe installed are recommended as a good check on pipe installation quality. Never let pipe laying get too far ahead before verifying the installation quality. This will permit early detection and correction of inadequate installation methods.

Pipes installed with initial deflections exceeding the values in **Table 9-1** must be reinstalled so the initial deflection is less than those values. See **section 9.2**, correcting over-deflected Pipe, for limitations applicable to this work.

Procedure for checking the initial diametrical deflection for installed pipes:

- 1 Complete backfilling to grade.
- 2 Complete removal of temporary sheeting (if used).
- 3 Turn off the dewatering system (if used).
- 4 Measure and record the pipe's vertical diameter.  
**Note:** For small diameter pipes, a deflection testing device (commonly called a pig) may be pulled through the pipes to measure the vertical diameter.

	Initial deflection % of the diameter
Large diameter (DN ≥ 300)	3.0
Small diameter (DN ≤ 250)	2.5

**Table 9-1 Allowable initial vertical deflection**

5 Calculate vertical deflection:

$$\% \text{ Deflection} = \frac{\text{Actual I.D.} - \text{Installed Vertical I.D.}}{\text{Actual I.D.}} \times 100$$

Actual I.D. may be verified or determined by measuring the diameters of a pipe not yet installed laying loose (no pipes stacked above) on a reasonably plain surface. Calculate as follows:

$$\text{Actual I.D.} = \frac{\text{Vertical I.D.} + \text{Horizontal I.D.}}{2}$$

(See **Figure 9-1**)

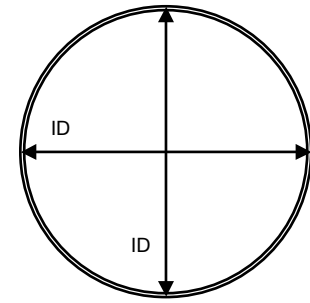

**Figure 9-1 Determining actual pipe ID on a pipe not yet installed**

## 9.2 Pipe Misalignment

The maximum allowable misalignment of adjacent pipe ends is 5 mm (see **Figure 9-2** below). It is recommended that the misalignment be monitored near thrust blocks, valve chambers and similar structures, and at closure or repair locations.

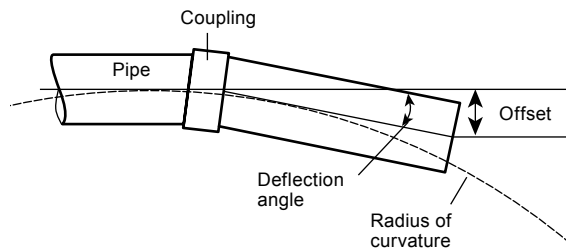

**Figure 9-2 Flowtite coupling, angular joint deflection**

### Correcting Over-Deflected Pipe

Pipes installed with initial diametrical deflections exceeding the values in **Table 9-1** must be corrected to ensure the long-term performance on the pipe.

#### Procedure

For the pipe deflected up to 8% of diameter:

- 1 Excavate down to the haunch area, which is approximately 85% of the pipe diameter. Excavation just above and at the sides of the pipe should be done utilizing hand tools to avoid impacting the pipe with heavy equipment (**Figure 9-3**).
- 2 Inspect the pipe for damage. Damaged pipe should be repaired or replaced.

- 3 Re-compact haunch backfill, insuring it is not contaminated with unacceptable backfill material.
- 4 Re-backfill the pipe zone in lifts with the appropriate material, compacting each layer to the required relative compaction density.
- 5 Backfill to grade and check the pipe deflections to verify they have not exceeded the initial values in **Table 9-1**.

For the pipe deflected greater than 8% of the pipe diameter: Pipes with over 8% deflection should be replaced completely.

- ! Caution:** Do not attempt to jack or wedge the installed over-deflected pipe into a round condition. This may cause damage to the pipe.

If excavating multiple pipes, care must be taken not to mound the cover from one pipe over the adjacent one. The extra cover and reduction of side support could magnify the over-deflection situation.

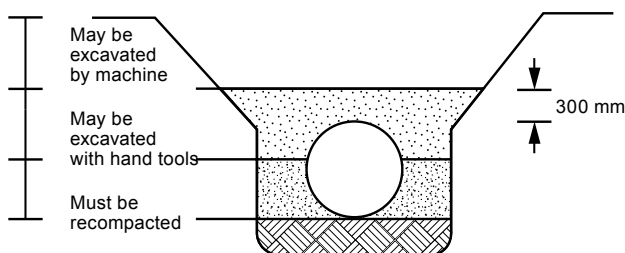

**Figure 9-3 Excavating over-deflected pipe**

## 9.3 Field Hydrotesting

Some job specifications require the completed pipe installation to be hydrostatically tested prior to acceptance and service. This is good practice as it can permit early detection and correction of some installation flaws, damaged products, etc. If a field hydrotest is specified, it must be done regularly as installation proceeds. Good construction practice would be not to exceed pipe testing with installation by more than approximately 1000 metres in order to properly assess the quality of work. The first field hydrotest should include at least one air valve or drainage chamber to assess the total pipeline system. In addition to routine care, normal precautions and typical procedures used in this work, the following suggestions should be noted:

- 1 Preparation prior to test – Inspect the completed installation to assure that all work has been finished properly. Of critical importance are:
  - Initial pipe deflection limited to the values in **Table 9-1**.

- Joints assembled correctly.
- System restraints (i.e. thrust blocks and other anchors) in place and properly cured.
- Flange bolting torqued per instructions.
- Backfilling completed. see **section A.6** on minimum burial depth, high pressure and testing limitations.
- Valves and pumps anchored.
- Backfill and compaction near structures and at closure pieces have been properly carried out.

- 2 Filling the line with water – Open valves and vents, so that all air is expelled from the line during filling, avoid pressure surges.
- 3 Pressurize the line slowly. Considerable energy is stored in a pipeline under pressure, and this power should be respected.
- 4 Ensure that the gauge location will read the highest line pressure or adjust accordingly. Locations lower in the line will have higher pressure due to additional head.
- 5 Ensure the maximum test pressure does not exceed  $1.5 \times PN$ . Normally the field test pressure is either a multiple of the operating pressure or the operating pressure plus a small incremental amount. However, in no case should the maximum field test pressure exceed  $1.5 \times PN$ .

- 6 If after a brief period for stabilization the line does not hold constant pressure, ensure that thermal effect (a temperature change), system expansion or entrapped air is not the cause. If the pipe is determined to be leaking and the location is not readily apparent, the following methods may aid discovery of the problem source:
  - Check flange and valve areas.
  - Check line tap locations.
  - Use sonic detection equipment.
  - Test the line in smaller segments to isolate the leak.

## 9.4 Field Joint Tester

Portable hydraulic field joint test equipment can be specially ordered and supplied for diameters 800 mm and above.

This equipment can be used to internally test selected pipe joints. It is required that each pipe adjacent to the joint under test be backfilled sufficiently to prevent pipe movement during testing. Additional details are available from the supplier's field technician.

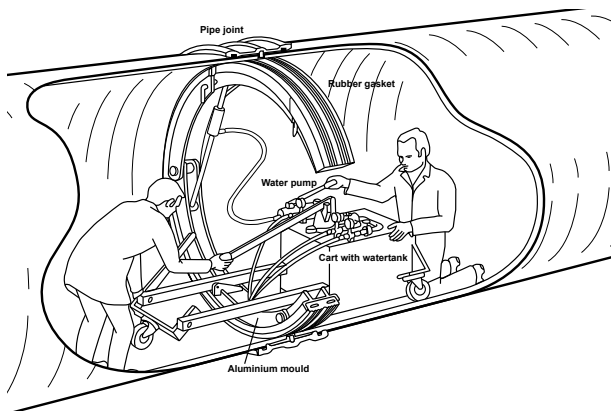

Figure 9-4 Field joint tester

**! Caution:** This equipment is designed to allow a test of the joint to verify that the joint has been assembled properly with gaskets in proper position. This equipment is limited to a maximum pressure test level of 6 bars.

## 9.5 Field Air Test

An alternative leak test for gravity pipe (PN 1 bar) systems may be conducted with air pressure instead of water. In addition to routine care, normal precautions and typical procedures used in this work, the following suggestions and criteria should be noted:

- 1 As with the hydrotest, the line should be tested in small segments, usually the pipe contained between adjacent manholes.
- 2 Ensure the pipeline and all materials, stubs, accesses, drops, etc. are adequately capped or plugged and braced against the internal pressure.
- 3 Slowly pressurize the system to 0.24 bar. The pressure must be regulated to prevent over pressurisation (maximum 0.35 bar).
- 4 Allow the air temperature to stabilise for several minutes while maintaining the pressure at 0.24 bar.

5 During this stabilisation period, it is advisable to check all plugged and capped outlets with a soap solution to detect leakage. If leakage is found at any connection, release the system pressure, seal the leaky cap(s) or plug(s) and begin the procedure again at Step 3.

6 After the stabilisation period, adjust the air pressure to 0.24 bar and shut-off or disconnect the air supply.

7 The pipe system passes this test if the pressure drop is 0.035 bar or less during the time periods given in **Table 9-2**.

8 Should the section of line under test fail the air test acceptance requirements, the pneumatic plugs can be coupled fairly close together and moved up or down the line, repeating the air test at each location, until the leak is found. This leak location method is very accurate, pinpointing the location of the leak to within one or two metres. Consequently, the area that must be excavated to make repairs is minimized, resulting in lower repair costs and considerably saved time.

**! Caution: CONSIDERABLE ENERGY IS STORED IN A PIPELINE UNDER PRESSURE. THIS IS PARTICULARLY TRUE WHEN AIR (EVEN AT LOW PRESSURES) IS THE TEST MEDIUM. TAKE GREAT CARE TO BE SURE THAT THE PIPELINE IS ADEQUATELY RESTRAINED AT CHANGES IN LINE DIRECTION AND FOLLOW MANUFACTURERS' SAFETY PRECAUTIONS FOR DEVICES SUCH AS PNEUMATIC PLUGS.**

**! Note:** This test will determine the rate at which air under pressure escapes from an isolated section of the pipeline. It is suited to determining the presence or absence of pipe damage and/or improperly assembled joints.

Diameter (mm)	Time (min.)	Diameter (mm)	Time (min.)
100	2.50	1000	25.00
150	3.75	1100	27.50
200	5.00	1200	30.00
250	6.25	1300	32.50
300	7.75	1400	35.00
350	8.75	1500	37.50
400	10.00	1600	40.00
500	12.50	1800	45.00
600	15.00	2000	50.00
700	17.50	2200	55.00
800	20.00	2400	60.00
900	22.50		

Table 9-2 Test time – Field air test

## 9.6 Cleaning of Flowtite Pipes

There are several methods used to clean gravity sewer lines, depending on diameter and the degree and nature of blockage. All of these methods use either mechanical means or water jet to clean the interior of the pipe. When mechanical means are employed, we recommend the use of plastic scrapers to avoid damage to the pipe's inner surface.

The use of high pressure water, emitted through jet nozzles, is a practice followed in some countries for cleaning sewer pipes. However, water emitted under high pressure through a jet nozzle can cause damage to most materials if not properly controlled. Based on experience gained with water jet cleaning of GRP sewer pipes, the following guidelines must be adhered to in order to avoid damage to the installed pipes. If you are unsure about the most suitable cleaning method for your pipeline, please do not hesitate to contact your Flowtite partner in advance.

### Cleaning of Sewer and Pressure-Sewer Pipes (FS and FPS)

- 1** Maximum input up to 120 bars\*. Due to the smooth interior surface of GRP pipe, adequate cleaning and removal of blockages can normally be achieved below this pressure.
- 2** Nozzles with jet holes around the circumference are to be preferred. Nozzles with cleaning chains or wires, as well as rotating, aggressive or damaging nozzles are to be avoided.
- 3** The water discharge angle should not be greater than 30°. An angle smaller than 20° is usually sufficient for GRP pipe, as the smooth surface of the material inhibits adhesion and only washing of the interior is required.
- 4** The number of jet holes should be 6 to 8 and the hole size must be at least 2.4 mm.
- 5** The external surface of the nozzle shall be smooth and the maximum weight 4.5 kg. Nozzle length, corresponding that weight, should be at least 170 mm. For small and medium range diameters (DN100 - 800) the lighter nozzles (approximately 2.5 kg) shall be used.
- 6** The forward and backward moving speed of the nozzle shall be limited to 30 m/min. Uncontrolled movement of the nozzle is not allowed. When inserting the nozzle into the pipe care should be taken to prevent it from hitting the pipe wall.
- 7** Jetting/swabbing sleds with several runners give a greater distance between the nozzle and the pipe wall, resulting in a less aggressive cleaning.

- 8** The use of equipment or pressures that do not meet the above criteria could cause damage to the installed pipe.

Minor, local chipping of the surface of the abrasion layer are not considered to have detrimental effect on the operational performance of the pipe.



**Figure 9-5** Nozzle with jet holes around the circumference, 4.5 kg



**Figure 9-6** Nozzle with jet holes around the circumference, 2.5 kg

\*The cleaning is only allowed to be done with a jet-power-density of 330 W/mm<sup>2</sup>. Experiences have shown that if one uses the set up nozzle and jet holes and a flow rate of 300 l/min, a pressure of 120 bars will occur.

**For further questions please consult the supplier.**

### Cleaning of Pressure Pipes (FP)

These guidelines are to be used when Flowtite pressure pipes (FP) are used in sewer applications.

- 1** Maximum input up to 80 bars. Due to the smooth interior surface of GRP pipe, adequate cleaning and removal of blockages can normally be achieved below this pressure.
- 2** Nozzles with jet holes around the circumference are to be preferred. Nozzles with cleaning chains or wires, as well as rotating, aggressive or damaging nozzles are to be avoided.
- 3** The water discharge angle must be between 6° and 15° relative to the pipe axis.
- 4** The number of jet holes should be 6 to 8 or more and the holes size must be at least 2.4 mm.
- 5** The external surface of the nozzle shall be smooth and the maximum weight should be 2.5 kg.



- 6** The forward and backward moving speed of the nozzle shall be limited to 30 m/min. Uncontrolled movement of the nozzle is not allowed. When inserting the nozzle into the pipe care should be taken to prevent it from hitting the pipe wall.
- 7** Jetting/swabbing sleds with several runners that give a greater distance between the nozzle and the pipe wall are required (see **Figure 9-7**).
- 8** The use of equipment or pressures that do not meet the above criteria could cause damage to the installed pipe.

**For further questions please consult the supplier.**



**Figure 9-7 Jetting/swabbing sleds**

# 10 Alternative Installations

If the burial depth requirements for the selected pipe stiffness, installation type and soil class exceed feasible limits due to poor native soil, alternative installation procedures must be considered.

Three alternative installation methods are available:

- Wider Trench
- Permanent Sheet piling (see **section 7.5** →)
- Stabilised Backfill (Cement)

## 10.1 Wide Trench

Increasing the trench width places the pipe further away from the soft native soil, allowing a deeper installation and higher allowable negative pressure (vacuum).

## 10.2 Cement Stabilised Backfill

### Scope

Cement is mixed with moist sandy soil, and the mixture placed and compacted as a typical backfill soil. The amount of type 3 Portland cement added to the sandy soil is approximately 4 to 5 parts per hundred weight of the soil. The moisture level should be in the range of 5 to 10%. The compaction density required is dependent on the cover depth prior to allowing the stabilised backfill to set. If the desired cover depth is small, the required density is low. The cement-stabilised backfill can set in one or two days and the cover fill can be placed to grade, with a maximum total cover depth of 5 metres.

### Mixture

100 parts soil (dry weight), 4 to 5 parts type 3 Portland cement, and 12% water (+/-6%). Account for the natural moisture content of the soil when adding water. The soil can be class SC II or SC III. Class SC II soil is the easiest to mix; however, the other class may be used. Mixing can be accomplished on the ground by spreading a layer of backfill soil and a thin layer of cement over it, and then mixing the two together. The mixing can be done by hand, with a hoe, or mechanically with any appropriate device. The backfill should be placed within two hours of mixing.

### Compaction

The cement-stabilised backfill will achieve a high stiffness without the need for significant compaction. Be sure to place a backfill under the pipe haunches and compact with a haunch-compaction tool. A Whacker compactor is required to compact the cement-stabilised backfill next to the pipe. One pass of the compactor with 300 mm lifts is sufficient for most conditions in

which the cover depth is less than 2 metres. Check the pipe deflection to assure the compaction is adequate to support the pipe. If initial deflection exceeds 2.5%, increase the amount of compaction or use less cover until the cement-stabilised backfill sets in one or two days. If a significant depth of cover is to be placed before the cement-stabilised backfill is allowed to set, a higher level of compaction is required to prevent excessive pipe deflection. Keep the initial deflection to no more than 2.5%. The amount of compaction effort required is dependent on cover depth, lift height and specific soil used in the mixture.

It is also recommended that a stabilised backfill be used in the immediate vicinity of large thrust blocks, or valve chambers and in areas of significant over-excavation.



# Appendix AWWA M 45

01

02

03

04

05

06

07

08

09

10

app.

<b>Appendix A</b>	<b>Installation Design</b> .....	<b>45</b>
<b>A.1</b>	<b>Design Principles</b> .....	<b>45</b>
<b>A.2</b>	<b>Native Soil Stiffness Groups</b> .....	<b>47</b>
<b>A.3</b>	<b>Backfill Constrained Modulus, <math>M_{sb}</math></b> .....	<b>47</b>
<b>A.4</b>	<b>Trench Width</b> .....	<b>49</b>
<b>A.5</b>	<b>Negative Pressure</b> .....	<b>49</b>
<b>A.6</b>	<b>Burial Limitation – Minimum</b> .....	<b>50</b>
<b>A.7</b>	<b>Seismic Loading</b> .....	<b>50</b>
<b>A.8</b>	<b>Backfill Migration</b> .....	<b>51</b>
<b>Appendix B</b>	<b>Installation Tables</b> .....	<b>51</b>
<b>Appendix C</b>	<b>Classification and Properties of Native Soils</b> .....	<b>67</b>
<b>Appendix D</b>	<b>Classification and Properties of Backfill Soils</b> .....	<b>68</b>
<b>Appendix E</b>	<b>Field Testing to Assist Classification of Native Soils</b> .....	<b>70</b>
<b>Appendix F</b>	<b>Compaction of Backfill</b> .....	<b>70</b>
<b>Appendix G</b>	<b>Approximate Weights of Pipes and Couplings</b> .....	<b>72</b>
<b>Appendix H</b>	<b>Joint Lubricant Requirements</b> .....	<b>73</b>
<b>Appendix I</b>	<b>Definitions and Terminology</b> .....	<b>74</b>

- 01
- 02
- 03
- 04
- 05
- 06
- 07
- 08
- 09
- 10
- app.

## Appendix A Installation Design

The long life and good performance of Flowtite pipe is ensured by proper handling and installation. Flowtite pipes are flexible and allow the designer to utilize the bedding and pipe zone backfill for support. Together the pipe and embedment material form a “pipe-soil system” that provides proven long-term performance.

The two most widely accepted design methodologies regarding the installation of GRP pipes are based on recommendations of the Abwassertechnischen Vereinigung (ATV) of Germany and the American Water Works Association (AWWA). Both of these methods have been successfully used for decades. This Appendix is based on the current AWWA approach.

### A.1 Design Principles

A flexible pipe like Flowtite will deflect when subjected to soil and traffic loads. When deflected, the increase of the horizontal diameter will cause passive soil resistance to counteract the deflection. The amount of deflection needed to generate sufficient earth pressure to resist any given load will primarily depend on the stiffness of the backfill material and native soil, as well as trench width. The initial deflection of the pipe (measured after backfilling to level) can therefore be considered as a direct indicator of the quality of the pipe installation.

Settlement and consolidation of the soil surrounding the pipe will result in an increase of the pipe deflection over time. Almost all of the increase in deflection will take place during the first 1 to 2 years after installation. After that the deflection will stabilise.

The initial deflections must not exceed the values given in **Table A–1**. Pipes installed outside these limits may not perform as intended.

	Initial deflection % of the diameter
Large Diameter (DN ≥ 300)	3.0
Small Diameter (DN ≤ 250)	2.5

**Table A–1 Allowable initial vertical deflection**

The type of installation appropriate for Flowtite pipes varies with native soil characteristics, cover depth, loading conditions and available backfill materials. The native soil and backfill material must adequately confine the pipe to achieve proper pipe support.

The support of the surrounding soil is defined in terms of the constrained or one dimensional soil modulus,  $M_s$ , at pipe elevation. To determine  $M_s$  for a buried pipe, separate  $M_s$  values for native soil,  $M_{sn}$ , and the pipe backfill surround,  $M_{sb}$ , must be determined and then combined depending on the trench width.

The most important installation design parameters are indicated in **Figure A–1**. The native soil stiffness, burial depth, groundwater level, life load and internal vacuum must be determined according to the conditions along the route of the planned pipe installation. Based upon this information and available backfill material, backfill compaction, trench width and pipe stiffness is selected.

Pipe installation design tables showing minimum backfill compaction are given in **Appendix B** →.

The most commonly encountered installation and operating conditions are covered. Tables are provided for selected combinations of 1) groundwater level, 2) traffic load, 3) internal vacuum and 4) trench width.

The tables show minimum backfill compaction at different burial depths for all practical combination of backfill materials, native soils and pipe stiffness. All of the tables are valid for working pressure anywhere in the range from atmospheric to nominal pressure of the pipe.

The expected initial pipe deflection is less than 2% for most installations given in **Appendix B**. Therefore, while initial deflections in **Table A-1** are acceptable for the pipe performance, a value exceeding the expected amount indicates the installation intended has not been achieved and should be improved for the next pipes (i.e. increased pipe zone backfill compaction, coarser grained pipe zone backfill materials or wider trench, etc.).

Appendices from C through I give information on both native and backfill soils.

- **Appendix C** – Classification and Properties of Native Soils
- **Appendix D** – Classification and Properties of Backfill Soils
- **Appendix E** – Field Testing to Assist Classification of Native Soils
- **Appendix F** – Compaction of Backfill
- **Appendix I** – Definitions and Terminology

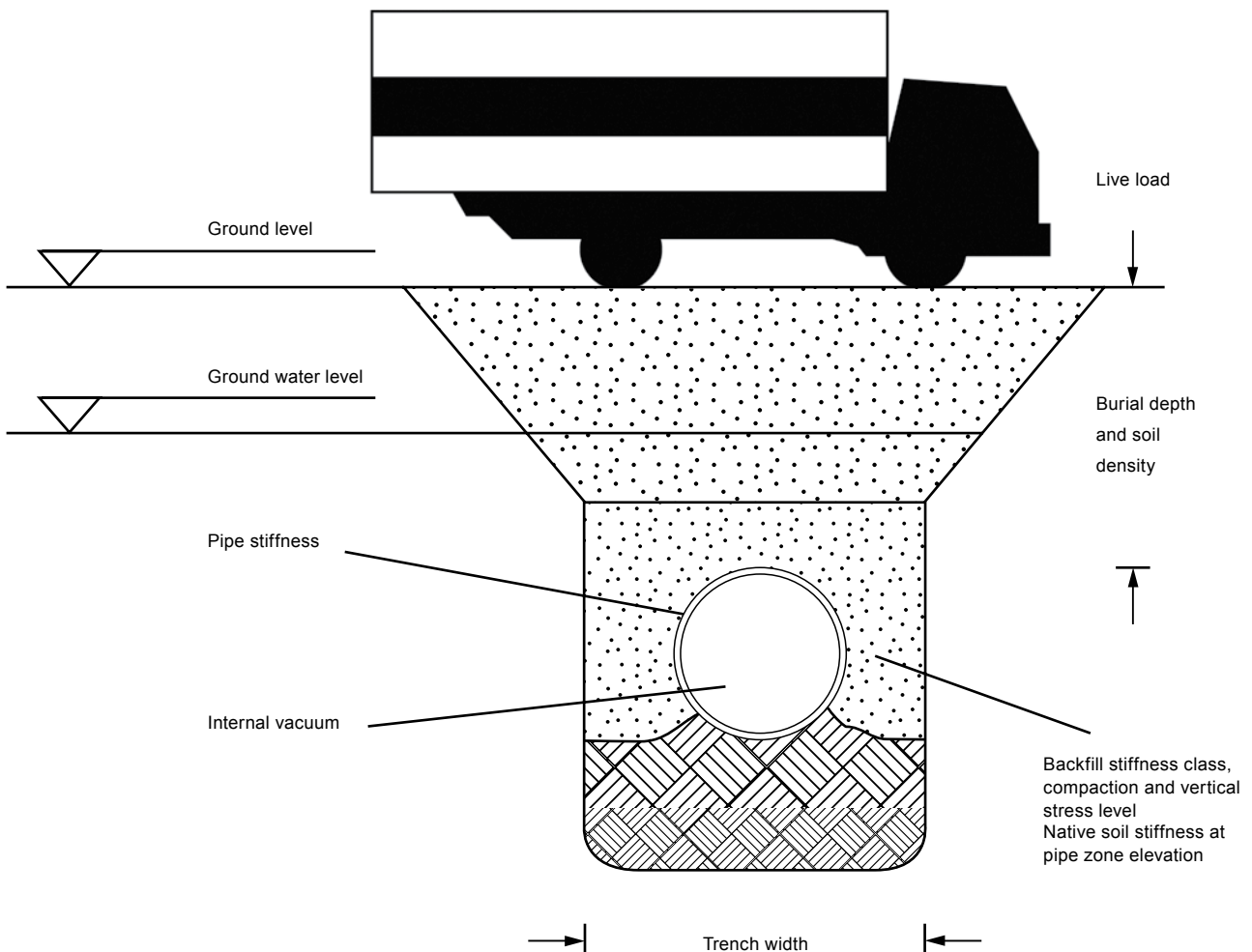

**Figure A-1 Installation design parameters**

01
02
03
04
05
06
07
08
09
10
app.

## A.2 Native Soil Stiffness Groups

The support of the native soil is defined in terms of the constrained or one dimensional soil modulus  $M_{sn}$  at pipe elevation. For design of pipe installations, native soils are grouped in stiffness groups. In **Table A–2** contains brief descriptions of the native soil stiffness groups. **Appendix C** gives detailed definitions for native soil groups [→](#).

Testing of native soil should be done frequently and particularly where changes are suspected. Properties of importance are those obtained at the bed and pipe zone elevation. The blow counts or soil strengths must represent the most severe (weakest) condition expected to exist for any significant period of time (normally this occurs when the water table is at its highest elevation).

## A.3 Backfill Constrained Modulus, $M_{sb}$

The measure of the level of backfill soil support is expressed as the constrained soil modulus  $M_{sb}$  in MPa. For design of pipe installations, suitable backfill soils are classified in 4 different stiffness soil classes, SC I, SC II, SC III and SC IV.

A brief description of the backfill soil classes is given in **Table A–3**

For any given backfill soil classes, the higher the compaction the higher the soil modulus and the higher the support. In addition, the soil modulus also increases with the vertical soil stress level, i.e. with burial depth.

**Table A–4 to Table A–7** give the  $M_{sb}$  values for backfill soil classes SC I, SC II, SC III and SC IV as a function of the % Standard Proctor Density (SPD) and vertical stress level. The values apply to pipes installed above the groundwater level. For pipes installed below groundwater level, the constrained soil modulus will be reduced for lower stiffness class soils and lower compaction, see values in parentheses. The vertical stress level is the vertical effective soil stress at the pipe springline elevation. It is normally computed as the design soil unit weight times the depth of fill. Buoyant unit weight should be used below the groundwater level.

For description of backfill soil stiffness categories, see **Appendix D** [→](#).

Soil class	Granular		Cohesive		Modulus $M_{sn}$ MPa
	Blow count <sup>1</sup>	Description	$q_u$ kPa	Description	
-	> 50	Very dense	> 600	Very hard	138.0
-	30 – 50	Dense	400 – 600	Hard	69.0
1	15 – 30	Compact	200 – 400	Very stiff	34.5
2	8 – 15	Slightly compact	100 – 200	Stiff	20.7
3	4 – 8	Loose	50 – 100	Medium	10.3
4	2 – 4		25 – 50	Soft	4.8
5	1 – 2	Very loose	13 – 25	Very soft	1.4
6	0 – 1	Very	0 – 13	Very very soft	0.34

<sup>1</sup> Standard penetration test per ASTM D1586

**Table A–2 Native soil stiffness groups. Values of Constrained Modulus,  $M_{sn}$**

Backfill Soil soil class	Description of Backfill Soils
SC I	Crushed rock with < 15% sand, maximum 25% passing the 9.5 mm sieve and maximum 5% fines <sup>2</sup> .
SC II	Clean, coarse-grained soils: SW, SP <sup>1</sup> , GW, GP or any soil beginning with one of these symbols with 12% or less fines <sup>2</sup> .
SC III	Clean, coarse-grained soils with fines: GM, GC, SM, SC or any soil beginning with one of these symbols with 12% or more fines <sup>2</sup> . Sandy or gravely fine-grained soils: CL, ML, (or CL-ML, CL/ML, ML/CL) with 30% or more retained on a no. 200 sieve.
SC IV	Fine grained soils: CL, ML, (or CL-ML, CL/ML, ML/CL) with 30% or less retained on a no. 200 sieve.

Note: Symbols in the table are according to the Unified Soil Classification Designation, ASTM D2487

<sup>1</sup>) Uniform fine sand, SP, with more than 50% passing no. 100 sieve (0.15 mm) is very sensitive to moisture and is not recommended as backfill.

<sup>2</sup>) % fines is the weight percentage of soil particles that pass no. 200 sieve with 0.076 mm opening.

**Table A–3 Backfill soil class classification**

Burial Depth (Soil Density 18.8 kN/m <sup>3</sup> ) m	Vertical Stress Level kPa	Compaction, % maximum Standard Proctor Density	
		Compacted MPa	Uncompacted (dumped) MPa
0.4	6.9	16.2	13.8
1.8	34.5	23.8	17.9
3.7	69.0	29.0	20.7
7.3	138.0	37.9	23.8
14.6	276.0	51.7	29.3
22.0	414.0	64.1	34.5

**Table A-4**  $M_{sb}$  for SC I Backfill Soil

**!** Note: Dumped material should always be worked into the haunch zone.

Burial Depth (Soil Density 18.8 kN/m <sup>3</sup> ) m	Vertical Stress Level kPa	Compaction, % maximum Standard Proctor Density			
		100 MPa	95 MPa	90 MPa	85 MPa
0.4	6.9	16.2	13.8	8.8 (7.5)	3.2 (2.2)
1.8	34.5	23.8	17.9	10.3 (8.8)	3.6 (2.5)
3.7	69.0	29.0	20.7	11.2 (9.5)	3.9 (2.7)
7.3	138.0	37.9	23.8	12.4 (10.5)	4.5 (3.2)
14.6	276.0	51.7	29.3	14.5 (12.3)	5.7 (4.0)
22.0	414.0	64.1	34.5	17.2 (14.6)	6.9 (4.8)

**Table A-5**  $M_{sb}$  for SC II Backfill Soil (reduced values below ground water table in parentheses)

Burial Depth (Soil Density 18.8 kN/m <sup>3</sup> ) m	Vertical Stress Level kPa	Compaction, % maximum Standard Proctor Density			
		100 MPa	95 MPa	90 MPa	85 MPa
0.4	6.9	-	9.8 (4.9)	4.6 (2.3)	2.5 (1.3)
1.8	34.5	-	11.5 (5.8)	5.1 (2.6)	2.7 (1.4)
3.7	69.0	-	12.2 (6.1)	5.2 (2.6)	2.8 (1.4)
7.3	138.0	-	13.0 (6.5)	5.4 (2.7)	3.0 (1.5)
14.6	276.0	-	14.4 (7.2)	6.2 (3.1)	3.5 (1.8)
22.0	414.0	-	15.9 (8.0)	7.1 (3.6)	4.1 (2.1)

**Table A-6**  $M_{sb}$  for SC III Backfill Soil (values below ground water level in parentheses)

Burial Depth (Soil Density 18.8 kN/m <sup>3</sup> ) m	Vertical Stress Level kPa	Compaction, % maximum Standard Proctor Density			
		100 MPa	95 MPa	90 MPa	85 MPa
0.4	6.9	-	3.7 (1.11)	1.8 (0.54)	0.9 (0.27)
1.8	34.5	-	4.3 (1.29)	2.2 (0.66)	1.2 (0.36)
3.7	69.0	-	4.8 (1.44)	2.5 (0.75)	1.4 (0.42)
7.3	138.0	-	5.1 (1.53)	2.7 (0.81)	1.6 (0.48)
14.6	276.0	-	5.6 (1.68)	3.2 (0.96)	2.0 (0.60)
22.0	414.0	-	6.2 (1.86)	3.6 (1.08)	2.4 (0.72)

**Table A-7**  $M_{sb}$  for SC IV Backfill Soil (values below ground water level in parentheses)

**!** Note:  $M_{sb}$  values at intermediate vertical stress levels not given in **Table A-4** to **Table A-7** can be obtained by interpolation.

**!** Note: The % maximum standard Proctor density indicates the dry density of the compacted soil as a percentage of maximum dry density determined in accordance with ASTM D698.



## A.4 Trench Width

The soil support for a buried pipe installation, expressed as the composite constrained soil modulus,  $M_s$ , depends on the constrained modulus of both the backfill and native soil,  $M_{sb}$  and  $M_{sn}$ , as well as the trench width.

For pipe installation in soft native soils where  $M_{sn}$  is lower than  $M_{sb}$ , the composite modulus,  $M_s$ , will be lower than the backfill modulus,  $M_{sb}$ . This effect is less pronounced for wider trenches and can be disregarded for trenches wider than 5 times the pipe diameter at elevation of the pipe springline. This means that a wider trench provides for better soil support.

For installations in firm native soils where  $M_{sn}$  is higher than  $M_{sb}$ , the composite modulus will be higher than the backfill modulus. This effect will be less pronounced for a wider trench, which in this case will provide less soil support.

The trench must always be wide enough to allow for adequate space to ensure proper placement and compaction of backfill in the haunch region. It must also be wide enough to safely operate compaction equipment without damaging the pipe.

## A.5 Negative Pressure

In order to provide proper soil stabilizing support, a minimum burial depth of 1.0 metre is recommended for negative pressure (vacuum) situations where the negative pressure is in excess of 0.25 bar for SN2500, 0.5 bar for SN5000 pipes.

The maximum allowable negative pressure (vacuum) in the pipe is a function of burial depth, native soil, pipe and backfill soil stiffness as well as trench width. See **Appendix B** → for backfill compaction requirements for conditions with vacuum in the pipe.

### Unburied Pipe Sections

Some sections of a buried pipeline, such as in valve pits or chambers, may be non-soil supported. As the stabilizing support of the soil is not present, the negative pressure capability has to be evaluated separately. **Table A-8** gives the maximum allowable negative pressure for lengths between restraints of 3, 6 and 12 metres.

DN mm	SN 2500				SN 5000				SN 10000			
	1,5 m	3 m	6 m	12 m	1,5 m	3 m	6 m	12 m	1,5 m	3 m	6 m	12 m
100-250	-	-	-	-	-	-	-	-	1,00	1,00	1,00	1,00
300	0,47	0,29	0,27	0,27	0,78	0,56	0,54	0,54	1,00	1,00	1,00	1,00
400	0,77	0,31	0,27	0,27	1,00	0,59	0,54	0,54	1,00	1,00	1,00	1,00
500	0,83	0,35	0,28	0,27	1,00	0,64	0,55	0,54	1,00	1,00	1,00	1,00
600	0,91	0,41	0,28	0,27	1,00	0,71	0,55	0,54	1,00	1,00	1,00	1,00
700	1,00	0,51	0,29	0,27	1,00	0,84	0,56	0,54	1,00	1,00	1,00	1,00
800	1,00	0,66	0,30	0,27	1,00	1,00	0,57	0,54	1,00	1,00	1,00	1,00
900	1,00	0,79	0,32	0,27	1,00	1,00	0,60	0,54	1,00	1,00	1,00	1,00
1000	1,00	0,81	0,34	0,27	1,00	1,00	0,62	0,54	1,00	1,00	1,00	1,00
1200	1,00	0,88	0,40	0,28	1,00	1,00	0,70	0,54	1,00	1,00	1,00	1,00
1400	1,00	1,00	0,49	0,28	1,00	1,00	0,82	0,55	1,00	1,00	1,00	1,00
1600	1,00	1,00	0,63	0,29	1,00	1,00	1,00	0,57	1,00	1,00	1,00	1,00
1800	1,00	1,00	0,77	0,31	1,00	1,00	1,00	0,59	1,00	1,00	1,00	1,00
2000	1,00	1,00	0,79	0,33	1,00	1,00	1,00	0,61	1,00	1,00	1,00	1,00
2400	1,00	1,00	0,87	0,39	1,00	1,00	1,00	0,69	1,00	1,00	1,00	1,00
2800	1,00	1,00	0,99	0,49	1,00	1,00	1,00	0,81	1,00	1,00	1,00	1,00
3200	1,00	1,00	1,00	0,62	1,00	1,00	1,00	0,98	1,00	1,00	1,00	1,00
3600	1,00	1,00	1,00	0,76	1,00	1,00	1,00	1,00	1,00	1,00	1,00	1,00
4000	1,00	1,00	1,00	0,78	1,00	1,00	1,00	1,00	1,00	1,00	1,00	1,00

**Table A-8 Maximum allowable negative pressure (bars) for unburied sections – Pipe length between restraints 3 m / 6 m / 12 m**

**!** **Note:** The restraints should be stiff enough to keep the pipe round.

## A.6 Burial Limitation – Minimum

### General

Minimum recommended burial depth for pipes with operating pressures of 10 bar or less is 0.5 metres provided that pipes are joined without vertical joint deflection. For operating and installation conditions involving traffic load, negative pressure, high pressure, high water table or frost, see requirements in the following sections.

### Traffic Loading

In situations where pipes are to be buried under a roadway, or continuing traffic loading is anticipated, the backfill material should be compacted to grade level. Consult road construction codes of practice for local requirements and recommendations. Minimum cover restrictions may be reduced with special installations such as concrete encasement, concrete cover slabs, castings, etc.

The installation tables in Appendix B are based on an assumed AASHTO HS20 load. In general, a minimum cover depth of 1.0 metre or more is recommended good practice for traffic loading using well compacted granular soils as backfill. **Table A–9** shows the recommended minimum cover depth for other traffic loadings. Less cover depths may be used when the system design permits that.

Load Type	Traffic (Wheel) Load (kN)	Recommended minimum Cover Depth (metres)
ATV LKW 12	40	0.6
ATV SLW 30	50	0.6
AASHTO HS20	72	0.8
AASHTO HS25	90	1.0
BS153 HA	90	1.0
ATV SLW 60	100	1.0
MOC	160	1.5
Cooper E80 Railroad Engine		3.0

**Table A–9 Recommended minimum cover depths with traffic load in standard conditions. Detailed depth calculation depends on project conditions.**

### Construction Traffic Loading

In some cases, large, heavy earth moving equipment or construction cranes may be present in or near the pipe installation area. These types of equipment can result in very high localised surface loads. The effects of such loading must be evaluated on a case by case basis to establish proper procedures and limits.

### Negative Pressure

A minimum burial depth of 1.0 metre is recommended for negative pressure (vacuum) situations where the negative pressure is in excess of 0.25 bar for SN2500, 0.5 bar for SN5000 pipes.

### High Pressure

High pressures require consideration of the possible uplift forces at joints both during operation and any field hydrotesting.

For operating pressures of 16 bar and greater the minimum burial depth should be 1.2 metres for pipes of DN 300 mm and larger and 0.8 metres for pipes of DN less than 300 mm.

During field hydrotesting at pressures below 16 bar, the couplings should be backfilled at least to the crown with pipes backfilled to the minimum cover depth. During field hydrotesting at pressures 16 bar and greater: For pipes in straight alignment, backfill to the crown of the coupling or higher before performing the field hydrotest. Pipes must be backfilled to minimum cover. For pipes installed with angular deflection, both the pipe and the coupling must be covered to the final grade before the field pressure test.

### High Water Table

A minimum of 0.75 diameter of earth cover (minimum dry soil bulk density of 19 kN/m<sup>3</sup>) is required to prevent an empty submerged pipe from floating.

Alternatively, the installation may proceed by anchoring the pipes. Details can be found in the **Table 5.2** →.

Consult the manufacturer for details on anchoring and minimum cover depth with anchors.

### Frost Line

The minimum cover depth for Flowtite pipe, as any other pipe material, should be such that the pipe is buried BELOW the anticipated frost level, or consult the local construction codes of practice for other techniques when installing the pipe within the frost level.

## A.7 Seismic Loading

Because of their flexibility Flowtite pipes have demonstrated excellent seismic behaviour. The structural analysis of pipes under earthquake loading is site specific, where moment magnitude, soil characteristics and the probability of the event are the main input. Consult your supplier for specific design considerations and analysis.

01
02
03
04
05
06
07
08
09
10
app.

## A.8 Backfill Migration

When open graded material is placed adjacent to a finer material, fines may migrate into the coarser material under the action of hydraulic gradient from groundwater flow. Significant hydraulic gradients may arise in the pipeline trench during construction, when water levels are controlled by pumping, or after construction, when permeable underdrain or embedment materials act as a drain under high ground water levels. Field experience shows that migration can result in significant loss of pipe support and increase of deflections.

The gradation and relative size of the embedment and adjacent materials must be compatible in order to minimize migration. In general, where significant groundwater flow is anticipated, avoid placing coarse, open-graded material, such as SC I, below or adjacent to finer material unless methods are employed to impede migration. Please take drainage properties of trenches into consideration. Consider the use of an appropriate soil filter or a geotextile filter fabric along the boundary of incompatible materials. The following filter gradation criteria may be used to restrict migration of fines into the voids of coarser material under hydraulic gradient:

- $D_{15}/d_{85} < 5$  where  $D_{15}$  is the sieve opening size passing 15 percent by weight of the coarser material and  $d_{85}$  is the sieve opening size passing 85 percent by weight of the finer material.
- $D_{50}/d_{50} < 25$  where  $D_{50}$  is the sieve opening size passing 50 percent by weight of the coarser material and  $d_{50}$  is the sieve opening size passing 50 percent by weight of the finer material. This criterion need not apply if the coarser material is well graded (see ASTM D 2487).

If the finer material is a medium to highly plastic clay (CL or CH), then the following criterion may be used in lieu of the  $D_{15}/d_{85}$  criteria:  $D_{15} < 0.5$  mm where  $D_{15}$  is the sieve opening size passing 15 percent by weight of the coarser material.

The aforementioned criteria may need to be modified if one of the materials is gap graded. Materials selected for use based on filter gradation criteria should be handled and placed in a manner that will minimize segregation.

Where incompatible materials must be used, they must be separated by filter fabric designed to last the life of the pipeline to prevent wash-away and migration. The filter fabric must completely surround the bedding and pipe zone backfill material and must be folded over the pipe zone area in order to prevent contamination of the selected backfill material.

## Appendix B Installation Tables

Pipe installation design tables showing minimum backfill compaction are given in this Appendix. The minimum backfill compaction is given at different burial depths for all practical combinations of backfill soil class, native soil stiffness group and pipe stiffness. Both standard,  $B_d/D = 1.8$  and wide,  $B_d/D = 3.0$ , trenches are covered. Tables are provided for selected combinations of 1) groundwater level, 2) traffic load and 3) internal vacuum. All of the tables are valid for working pressure anywhere in the range from atmospheric to nominal pressure of the pipe.

The minimum backfill compaction is expressed as percent standard Proctor density for backfill soil categories SC II, SC III and SC IV. For crushed rock as backfill, SC I, the minimum compaction is expressed either as uncompacted (dumped), D, or compacted, C. Note that SC I backfill material also has to be worked into the haunch zone for installation conditions where compaction is otherwise not required.

The compaction values recommended are to be considered as minimum values and field densities should be at or higher than the requirement. Include considerations for seasonal variations when assessing the potential for moisture content of both in situ and backfill soils. The backfill compaction tables are calculated following the current approach of AWWA assuming the soil and bedding properties listed below:

- Deflection lag factor,  $D_L = 1.5$
- Dry unit weight of overburden,  $\gamma_{s, dry} = 18.8$  kN/m<sup>3</sup>
- Wet (buoyant) unit weight of overburden,  $\gamma_{s, wet} = 11.5$  kN/m<sup>3</sup>
- Bedding coefficient (typical direct bury condition),  $k_x = 0.1$

Backfill compaction tables have been calculated for the loading and installation conditions listed in **Table B-1**, **Table B-2** and **Table B-3**.

**Table B-1** shows combinations calculated for large diameter pipes, DN  $\geq 300$  mm, to be installed with backfill configuration Type 1, see **Figure 3-4** .

**! Note:** For installations where both traffic load and vacuum can occur, use the highest compaction requirement of **Table B-5** and **Table B-6** for installations with groundwater below pipe and the highest of **Table B-8** and **Table B-9** for installation with groundwater to level.

Traffic Load AASHTO	Internal Vacuum bar	Ground Water	Trench Width at Pipe Springline $B_d/D$	Installation Table
0	0	Below pipe	1.8 and 3.0	Table B-4
HS 20	0	Below pipe	1.8 and 3.0	Table B-5
0	1	Below pipe	1.8 and 3.0	Table B-6
0	0	To level	1.8 and 3.0	Table B-7
HS 20	0	To level	1.8 and 3.0	Table B-8
0	1	To level	1.8 and 3.0	Table B-9

**Table B-1** Load combinations for Type 1 installation of  $DN \geq 300$  mm pipes

**Table B-2** shows combinations calculated for small diameter pipes,  $DN \leq 250$  mm, to be installed with backfill configuration Type 1, see **Figure 3-4** .

Traffic Load AASHTO	Internal Vacuum bar	Ground Water	Trench Width at Pipe Springline $B_d/D$	Installation Table
0	0	Below pipe	3.0 and 5.0	Table B-10
HS 20	0	Below pipe	3.0 and 5.0	Table B-10
0	1	Below pipe	3.0 and 5.0	Table B-10
0	0	To level	3.0 and 5.0	Table B-11
HS 20	0	To level	3.0 and 5.0	Table B-11
0	1	To level	3.0 and 5.0	Table B-11

**Table B-2** Load combinations for Type 1 installation of  $DN \leq 250$  mm pipes

 **Note:** For installations where both traffic load and vacuum can occur, use the highest compaction requirement of the two load cases.

**Table B-3** shows combinations calculated for large diameter pipes,  $DN \geq 300$  mm, to be installed with backfill configuration Type 2 (split), see **Figure 3-5** .

Internal Vacuum bar	Ground Water	Trench Width at Pipe Springline $B_d/D$	Backfill Below 0.6 x DN	Backfill Above 0.6 x DN		Installation Table
			Category	Category	% SPD	
0.0	Below pipe	1.8 and 3.0	SC I, SC II	SC III	85 / 90	Table B-12
0.0	Below pipe	1.8 and 3.0	SC I, SC II	SC IV	90	Table B-12
0.5	Below pipe	1.8 and 3.0	SC I, SC II	SC III	85 / 90	Table B-13
0.5	Below pipe	1.8 and 3.0	SC I, SC II	SC IV	90	Table B-13
1.0	Below pipe	1.8 and 3.0	SC I, SC II	SC III	85 / 90	Table B-14
1.0	Below pipe	1.8 and 3.0	SC I, SC II	SC IV	90	Table B-14
0.0	To level	1.8 and 3.0	SC I, SC II	SC III	85 / 90	Table B-15
0.0	To level	1.8 and 3.0	SC I, SC II	SC IV	95	Table B-15
0.5	To level	1.8 and 3.0	SC I, SC II	SC III	85 / 90	Table B-16
0.5	To level	1.8 and 3.0	SC I, SC II	SC IV	95	Table B-16
1.0	To level	1.8 and 3.0	SC I, SC II	SC III	85 / 90	Table B-17
1.0	To level	1.8 and 3.0	SC I, SC II	SC IV	95	Table B-17

**Table B-3** Load combinations for Type 2 installation of  $DN \geq 300$  mm pipes

For other installation and/or operating conditions, consult the appropriate AWWA or ATV installation design documents.

01  
02  
03  
04  
05  
06  
07  
08  
09  
10  
app.

Type 1 DN ≥ 300		No Traffic Load – No Internal Vacuum – Ground Water Level Below Pipe Invert																				<= Native Soil			
Backfill		Standard Trench, B <sub>d</sub> /D = 1.8												Wide Trench, B <sub>d</sub> /D = 3.0											
		SC I			SC II			SC III			SC IV			SC I			SC II			SC III			SC IV		
Burial Depth, m	Pipe SN	2500	5000	10000	2500	5000	10000	2500	5000	10000	2500	5000	10000	2500	5000	10000	2500	5000	10000	2500	5000		10000		
		1,0		D	D	D	85	85	85	85	85	85	90	90	90	D	D	D	85	85	85	85	85	85	90
1,5		D	D	D	85	85	85	85	85	85	90	90	90	D	D	D	85	85	85	85	85	85	90	90	90
2,0		D	D	D	85	85	85	85	85	85	90	90	90	D	D	D	85	85	85	85	85	85	90	90	90
3,0		D	D	D	85	85	85	85	85	85	90	90	90	D	D	D	85	85	85	85	85	85	90	90	90
5,0		D	D	D	85	85	85	85	85	85	90	90	90	D	D	D	85	85	85	90	90	85	95	95	90
8,0		D	D	D	85	85	85	90	90	90	95	95	95	D	D	D	90	90	90	90	90		95	95	
12,0		D	D	D	90	90	85	90	90	90				D	D	D	90	90	90	95	95	95			
20,0		D	D	D	90	90	90	95	95	95				D	D	D	90	90	90			95			
30,0		D	D	D	95	95	95							D	D	D	95	95	95						
1,0		D	D	D	85	85	85	85	85	85	90	90	90	D	D	D	85	85	85	85	85	85	90	90	90
1,5		D	D	D	85	85	85	85	85	85	90	90	90	D	D	D	85	85	85	85	85	85	90	90	90
2,0		D	D	D	85	85	85	85	85	85	90	90	90	D	D	D	85	85	85	85	85	85	90	90	90
3,0		D	D	D	85	85	85	85	85	85	90	90	90	D	D	D	85	85	85	85	85	85	90	90	90
5,0		D	D	D	85	85	85	85	85	85	90	90	90	D	D	D	85	85	85	90	90	85	95	95	90
8,0		D	D	D	85	85	85	90	90	90	95	95	95	D	D	D	90	90	90	95	90	90			95
12,0		D	D	D	90	90	90	95	95	90				D	D	D	90	90	90	95	95	95			
20,0		D	D	D	95	90	90			95				D	D	D	95	95	95						
30,0		C	C	C	100	100	100							D	D	D	95	95	95						
1,0		D	D	D	85	85	85	85	85	85	90	90	90	D	D	D	85	85	85	85	85	85	90	90	90
1,5		D	D	D	85	85	85	85	85	85	90	90	90	D	D	D	85	85	85	85	85	85	90	90	90
2,0		D	D	D	85	85	85	85	85	85	90	90	90	D	D	D	85	85	85	85	85	85	90	90	90
3,0		D	D	D	85	85	85	85	85	85	90	90	90	D	D	D	85	85	85	85	85	85	90	90	90
5,0		D	D	D	85	85	85	85	85	85	90	90	90	D	D	D	85	85	85	90	90	85	95	95	95
8,0		D	D	D	90	90	85	90	90	90	95	95	95	D	D	D	90	90	90	95	95	95			
12,0		D	D	D	90	90	90	95	95	95				D	D	D	90	90	90	95	95	95			
20,0		C	C	C	100	100	100							D	D	D	95	95	95						
30,0														C	D	D	100	95	95						
1,0		D	D	D	85	85	85	85	85	85	90	90	90	D	D	D	85	85	85	85	85	85	90	90	90
1,5		D	D	D	85	85	85	85	85	85	90	90	90	D	D	D	85	85	85	85	85	85	90	90	90
2,0		D	D	D	85	85	85	85	85	85	90	90	90	D	D	D	85	85	85	85	85	85	90	90	90
3,0		D	D	D	85	85	85	85	85	85	90	90	90	D	D	D	85	85	85	85	85	85	90	90	90
5,0		D	D	D	85	85	85	90	90	85	95	95	90	D	D	D	90	85	85	90	90	90	95	95	95
8,0		D	D	D	95	90	90	95	95	95				D	D	D	90	90	90	95	95	95			
12,0		C	C	D	100	100	95							D	D	D	90	90	90	95	95	95			
20,0														D	D	D	95	95	95						
30,0														C	C	C	100	100	100						
1,0		D	D	D	85	85	85	85	85	85	90	90	90	D	D	D	85	85	85	85	85	85	90	90	90
1,5		D	D	D	85	85	85	85	85	85	90	90	90	D	D	D	85	85	85	85	85	85	90	90	90
2,0		D	D	D	85	85	85	85	85	85	90	90	90	D	D	D	85	85	85	85	85	85	90	90	90
3,0		D	D	D	90	90	85	95	90	85			95	D	D	D	85	85	85	85	85	85	95	90	90
5,0		D	D	D	95	95	90			95				D	D	D	90	90	85	95	90	90			95
8,0		C	C	C	100	100	100							D	D	D	90	90	90	95	95	95			
12,0														D	D	D	95	95	95						
20,0														D	D	D	95	95	95						
30,0														C	C	C	100	100	100						
1,0		D	D	D	85	85	85	85	85	85	90	90	90	D	D	D	85	85	85	85	85	85	90	90	90
1,5		D	D	D	90	85	85	90	85	85	95	90	90	D	D	D	85	85	85	85	85	85	90	90	90
2,0		D	D	D	90	90	85	95	90	85			90	D	D	D	85	85	85	85	85	85	90	90	90
3,0		D	D	D	95	95	90			95				D	D	D	90	85	85	90	90	85	95	95	90
5,0				C			100							D	D	D	90	90	90	95	95	95			
8,0														D	D	D	95	90	90		95	95			
12,0														D	D	D	95	95	95						
20,0														C	C	C	100	100	100						
30,0														C	C		100	100							

**Table B-4 Installation Type 1, DN ≥ 300. Ground water level below pipe invert**  
 Minimum Backfill Compaction, % Standard Proctor Density. (D = uncompacted (dumped), C = Compacted)

01

02

03

04

05

06

07

08

09

10

app.

Type 1 DN ≥ 300		Traffic Load AASHTO HS 20 - No Internal Vacuum - Ground Water Below Pipe Invert																							
Backfill	Pipe SN	Standard Trench, $B_d/D = 1.8$												Wide Trench, $B_d/D = 3.0$											<= Native Soil
		SC I			SC II			SC III			SC IV			SC I			SC II			SC III			SC IV		
Burial Depth, m		2500	5000	10000	2500	5000	10000	2500	5000	10000	2500	5000	10000	2500	5000	10000	2500	5000	10000	2500	5000	10000	2500	5000	10000
1.0	D	D	D	85	85	85	85	85	85	90	90	90	D	D	D	85	85	85	85	85	85	90	90	90	
1.5	D	D	D	85	85	85	85	85	85	90	90	90	D	D	D	85	85	85	85	85	85	90	90	90	
2.0	D	D	D	85	85	85	85	85	85	90	90	90	D	D	D	85	85	85	85	85	85	90	90	90	
3.0	D	D	D	85	85	85	85	85	85	90	90	90	D	D	D	85	85	85	85	85	85	90	90	90	
5.0	D	D	D	85	85	85	85	85	85	90	90	90	D	D	D	85	85	85	90	90	85	95	95	95	
8.0	D	D	D	85	85	85	90	90	90	95	95	95	D	D	D	90	90	90	90	90	90			95	
12.0	D	D	D	90	90	85	90	90	90			95	D	D	D	90	90	90	95	95	95				
20.0	D	D	D	90	90	90	95	95	95				D	D	D	90	90	90		95					
30.0	D	D	D	95	95	95							D	D	D	95	95	95							
1.0	D	D	D	85	85	85	85	85	85	90	90	90	D	D	D	85	85	85	85	85	85	90	90	90	
1.5	D	D	D	85	85	85	85	85	85	90	90	90	D	D	D	85	85	85	85	85	85	90	90	90	
2.0	D	D	D	85	85	85	85	85	85	90	90	90	D	D	D	85	85	85	85	85	85	90	90	90	
3.0	D	D	D	85	85	85	85	85	85	90	90	90	D	D	D	85	85	85	85	85	85	90	90	90	
5.0	D	D	D	85	85	85	85	85	85	90	90	90	D	D	D	85	85	85	90	90	85	95	95	95	
8.0	D	D	D	85	85	85	90	90	90	95	95	95	D	D	D	90	90	90	95	90	90			95	
12.0	D	D	D	90	90	90	95	95	90				D	D	D	90	90	90	95	95	95				
20.0	D	D	D	95	90	90			95				D	D	D	95	95	95							
30.0	C	C	C	100	100	100							D	D	D	95	95	95							
1.0	D	D	D	85	85	85	85	85	85	90	90	90	D	D	D	85	85	85	85	85	85	90	90	90	
1.5	D	D	D	85	85	85	85	85	85	90	90	90	D	D	D	85	85	85	85	85	85	90	90	90	
2.0	D	D	D	85	85	85	85	85	85	90	90	90	D	D	D	85	85	85	85	85	85	90	90	90	
3.0	D	D	D	85	85	85	85	85	85	90	90	90	D	D	D	85	85	85	85	85	85	90	90	90	
5.0	D	D	D	85	85	85	85	85	85	90	90	90	D	D	D	85	85	85	90	90	85	95	95	95	
8.0	D	D	D	90	90	85	90	90	90	95	95	95	D	D	D	90	90	90	95	95	95				
12.0	D	D	D	90	90	90	95	95	95				D	D	D	90	90	90	95	95	95				
20.0	C	C	C	100	100	100							D	D	D	95	95	95							
30.0													C	D	D	100	95	95							
1.0	D	D	D	85	85	85	85	85	85	90	90	90	D	D	D	85	85	85	85	85	85	95	90	90	
1.5	D	D	D	85	85	85	85	85	85	90	90	90	D	D	D	85	85	85	85	85	85	90	90	90	
2.0	D	D	D	85	85	85	85	85	85	90	90	90	D	D	D	85	85	85	85	85	85	90	90	90	
3.0	D	D	D	85	85	85	85	85	85	90	90	90	D	D	D	85	85	85	85	85	85	95	90	90	
5.0	D	D	D	90	85	85	90	90	85	95	95	95	D	D	D	90	85	85	90	90	90	95	95	95	
8.0	D	D	D	95	90	90	95	95	95				D	D	D	90	90	90	95	95	95				
12.0	C	C	D	100	100	95							D	D	D	90	90	90	95	95	95				
20.0													D	D	D	95	95	95							
30.0													C	C	C	100	100	100							
1.0	D	D	D	90	85	85	95	90	85			95	90	90	90	90	90	90	90	90	90	95	95	90	
1.5	D	D	D	85	85	85	90	85	85	95	90	90	D	D	D	85	85	85	85	85	85	90	90	90	
2.0	D	D	D	85	85	85	90	85	85	95	95	90	D	D	D	85	85	85	85	85	85	90	90	90	
3.0	D	D	D	90	90	85	95	95	85			90	D	D	D	85	85	85	90	85	85	95	95	90	
5.0	D	D	D	95	95	90			95				D	D	D	90	90	90	95	90	90			95	
8.0	C	C	C	100	100	100							D	D	D	90	90	90	95	95	95				
12.0													D	D	D	95	95	95							
20.0													D	D	D	95	95	95							
30.0													C	C	C	100	100	100							
1.0	D	D	D	95	90	90			95				D	D	D	85	85	85	90	90	85	95	95	90	
1.5	D	D	D	90	90	85	95	95	90			95	D	D	D	85	85	85	90	85	85	95	95	90	
2.0	D	D	D	95	90	90		95	90				D	D	D	85	85	85	90	85	85	95	95	90	
3.0	D	D	D	95	95	90			95				D	D	D	90	85	85	90	90	85	95	95	95	
5.0			C		100								D	D	D	90	90	90	95	95	95				
8.0													D	D	D	95	95	90		95	95				
12.0													D	D	D	95	95	95							
20.0													C	C	C	100	100	100							
30.0													C	C	C	100	100	100							

**Table B-5 Installation Type 1, DN ≥ 300. Traffic Load – ground water level below pipe invert**  
 Minimum Backfill Compaction, % Standard Proctor Density. (D = uncompacted (dumped), C = Compacted)

Type 1 DN ≥ 300		No Traffic Load - 1 bar Internal Vacuum - Ground Water Level Below Pipe Invert																								
Backfill	Standard Trench, B <sub>d</sub> /D = 1.8												Wide Trench, B <sub>d</sub> /D = 3.0									<= Native Soil				
	SC I			SC II			SC III			SC IV			SC I			SC II			SC III				SC IV			
Pipe SN	2500	5000	10000	2500	5000	10000	2500	5000	10000	2500	5000	10000	2500	5000	10000	2500	5000	10000	2500	5000	10000	2500	5000	10000	Burial Depth, m	
1,0	D	D	D	85	85	85	85	85	85	90	90	90	D	D	D	85	85	85	85	85	85	95	90	90		Group 1
1,5	D	D	D	85	85	85	85	85	85	90	90	90	D	D	D	85	85	85	85	85	85	95	90	90		
2,0	D	D	D	85	85	85	85	85	85	90	90	90	D	D	D	85	85	85	90	85	85	95	90	90		
3,0	D	D	D	85	85	85	85	85	85	95	90	90	D	D	D	85	85	85	90	85	85	95	95	90		
5,0	D	D	D	85	85	85	90	85	85	95	90	90	D	D	D	90	85	85	90	90	85	95	95	90		
8,0	D	D	D	90	85	85	90	90	90	95	95	95	D	D	D	90	90	90	95	90	90		95	95		
12,0	D	D	D	90	90	85	95	90	90			95	D	D	D	90	90	90	95	95	95					
20,0	D	D	D	95	90	90		95	95				D	D	D	95	90	90			95					
30,0	C	D	D	100	95	95							C	D	D	100	95	95								
1,0	D	D	D	85	85	85	85	85	85	90	90	90	D	D	D	85	85	85	85	85	85	95	90	90	Group 2	
1,5	D	D	D	85	85	85	85	85	85	90	90	90	D	D	D	85	85	85	85	85	85	95	90	90		
2,0	D	D	D	85	85	85	85	85	85	90	90	90	D	D	D	85	85	85	90	85	85	95	90	90		
3,0	D	D	D	85	85	85	85	85	85	95	90	90	D	D	D	85	85	85	90	85	85	95	95	90		
5,0	D	D	D	85	85	85	90	85	85	95	90	90	D	D	D	90	85	85	90	90	85		95	90		
8,0	D	D	D	90	85	85	90	90	90	95	95	95	D	D	D	90	90	90	95	90	90			95		
12,0	D	D	D	90	90	90	95	95	90				D	D	D	90	90	90	95	95	95					
20,0	D	D	D	95	90	90			95				D	D	D	95	95	95								
30,0		C	C	100	100								C	D	D	100	95	95								
1,0	D	D	D	85	85	85	85	85	85	90	90	90	D	D	D	85	85	85	85	85	85	95	90	90		
1,5	D	D	D	85	85	85	85	85	85	90	90	90	D	D	D	85	85	85	90	85	85	95	90	90		
2,0	D	D	D	85	85	85	85	85	85	90	90	90	D	D	D	85	85	85	90	85	85	95	90	90		
3,0	D	D	D	85	85	85	85	85	85	95	90	90	D	D	D	90	85	85	90	85	85	95	95	90		
5,0	D	D	D	90	85	85	90	85	85	95	95	90	D	D	D	90	85	85	95	90	85		95	95		
8,0	D	D	D	90	90	85	95	90	90	95	95	95	D	D	D	90	90	90	95	95	95					
12,0	D	D	D	95	90	90		95	95				D	D	D	95	90	90		95	95					
20,0		C	C	100	100								D	D	D	95	95	95								
30,0													C	C	D	100	100	95								
1,0	D	D	D	85	85	85	85	85	85	95	90	90	D	D	D	85	85	85	90	85	85	95	90	90	Group 4	
1,5	D	D	D	85	85	85	90	85	85	95	90	90	D	D	D	85	85	85	90	85	85	95	95	90		
2,0	D	D	D	85	85	85	90	85	85	95	90	90	D	D	D	90	85	85	90	85	85	95	95	90		
3,0	D	D	D	90	85	85	90	85	85	95	90	90	D	D	D	90	85	85	90	90	85	95	95	90		
5,0	D	D	D	90	90	85	95	90	85		95	90	D	D	D	90	90	85	95	90	90		95	95		
8,0	D	D	D	95	90	90		95	95				D	D	D	90	90	90	95	95	95					
12,0		C	D	100	95								D	D	D	95	90	90		95	95					
20,0													C	D	D	100	95	95								
30,0														C	C		100	100								
1,0		D	D	95	90			95					D	D	D	90	90	85	95	90	85		95	95		Group 5
1,5		D	D	95	90			95	85			95	D	D	D	90	85	85	90	90	85		95	90		
2,0		D	D	95	90			95	90			95	D	D	D	90	85	85	90	90	85		95	90		
3,0		D	D	95	90			95	90				D	D	D	90	90	85	95	90	85		95	95		
5,0		C	D	100	95				95				D	D	D	90	90	85	95	95	90			95		
8,0			C	100	100								D	D	D	95	90	90		95	95					
12,0													D	D	D	95	95	95								
20,0													C	D	D	100	95	95								
30,0														C	C		100	100								
1,0			D	95	90			95					D	D	D	90	90	85	95	90	85		95	95	Group 6	
1,5			D	95	90			95					D	D	D	90	90	85	95	90	85		95	95		
2,0			D	95	95			95					D	D	D	90	90	85	95	90	90		95	95		
3,0			C	100	95								D	D	D	90	90	85	95	95	90		95	95		
5,0				C	100								D	D	D	95	90	90	95	95	95					
8,0													D	D	D	95	90	90		95	95					
12,0													C	D	D	100	95	95								
20,0													C	C	C	100	100	100								
30,0															C		100									

**Table B-6 Installation Type 1, DN ≥ 300. Vacuum 1.0 bar, ground water level below pipe invert**  
Minimum Backfill Compaction, % Standard Proctor Density. (D = uncompacted (dumped), C = Compacted)

- 01
- 02
- 03
- 04
- 05
- 06
- 07
- 08
- 09
- 10
- app.

01  
02  
03  
04  
05  
06  
07  
08  
09  
10  
app.

Type 1 DN ≥ 300		No Traffic Load - No Internal Vacuum - Ground Water Level to Ground Level																								
Backfill	Pipe SN	Standard Trench, B <sub>d</sub> /D = 1.8												Wide Trench, B <sub>d</sub> /D = 3.0												<= Native Soil
		SC I			SC II			SC III			SC IV			SC I			SC II			SC III			SC IV			
Burial Depth, m	2500	5000	10000	2500	5000	10000	2500	5000	10000	2500	5000	10000	2500	5000	10000	2500	5000	10000	2500	5000	10000	2500	5000	10000		
																									1,0	D
1,5	D	D	D	85	85	85	85	85	85	95	95	95	D	D	D	85	85	85	85	85	85	95	95	95		
2,0	D	D	D	85	85	85	85	85	85	95	95	95	D	D	D	85	85	85	85	85	85	95	95	95		
3,0	D	D	D	85	85	85	85	85	85		95	95	D	D	D	85	85	85	90	90	85			95		
5,0	D	D	D	85	85	85	90	90	90				D	D	D	90	90	85	95	95	90					
8,0	D	D	D	90	90	90	95	95	95				D	D	D	90	90	90	95	95	95					
12,0	D	D	D	90	90	90	95	95	95				D	D	D	90	90	90								
20,0	D	D	D	95	90	90							D	D	D	95	95	95								
30,0	C	D	D	100	95	95							C	D	D	100	95	95								
1,0	D	D	D	85	85	85	85	85	85	95	95	95	D	D	D	85	85	85	85	85	85	95	95	95		
1,5	D	D	D	85	85	85	85	85	85	95	95	95	D	D	D	85	85	85	85	85	85	95	95	95		
2,0	D	D	D	85	85	85	85	85	85	95	95	95	D	D	D	85	85	85	85	85	85	95	95	95		
3,0	D	D	D	85	85	85	85	85	85		95	95	D	D	D	85	85	85	90	90	85			95		
5,0	D	D	D	85	85	85	90	90	90				D	D	D	90	90	85	95	95	90					
8,0	D	D	D	90	90	90	95	95	95				D	D	D	90	90	90	95	95	95					
12,0	D	D	D	90	90	90	95	95	95				D	D	D	90	90	90								
20,0	D	D	D	95	95	95							D	D	D	95	95	95								
30,0		C	C		100	100							C	D	D	100	95	95								
1,0	D	D	D	85	85	85	85	85	85	95	95	95	D	D	D	85	85	85	85	85	85	95	95	95		
1,5	D	D	D	85	85	85	85	85	85	95	95	95	D	D	D	85	85	85	85	85	85	95	95	95		
2,0	D	D	D	85	85	85	85	85	85	95	95	95	D	D	D	85	85	85	85	85	85	95	95	95		
3,0	D	D	D	85	85	85	85	85	85		95	95	D	D	D	85	85	85	90	90	85			95		
5,0	D	D	D	85	85	85	90	90	90				D	D	D	90	90	85	95	95	95					
8,0	D	D	D	90	90	90	95	95	95				D	D	D	90	90	90			95					
12,0	D	D	D	95	90	90							D	D	D	95	90	90								
20,0		C	C		100	100							D	D	D	95	95	95								
30,0													C	C	C	100	100	100								
1,0	D	D	D	85	85	85	85	85	85	95	95	95	D	D	D	85	85	85	85	85	85	95	95	95		
1,5	D	D	D	85	85	85	85	85	85	95	95	95	D	D	D	85	85	85	85	85	85	95	95	95		
2,0	D	D	D	85	85	85	90	85	85		95	95	D	D	D	85	85	85	90	85	85		95	95		
3,0	D	D	D	90	90	85	95	95	90				D	D	D	90	85	85	95	90	90					
5,0	D	D	D	95	95	95							D	D	D	90	90	90	95	95	95					
8,0			C			100							D	D	D	95	90	90								
12,0													D	D	D	95	95	95								
20,0													C	C	C	100	100	100								
30,0														C	C		100	100								
1,0	D	D	D	85	85	85	90	85	85		95	95	D	D	D	85	85	85	85	85	85	95	95	95		
1,5	D	D	D	90	85	85	95	90	85			95	D	D	D	85	85	85	90	85	85		95	95		
2,0	D	D	D	90	90	85		95	85			95	D	D	D	85	85	85	90	90	85			95		
3,0	D	D	D	95	95	90							D	D	D	90	90	85	95	95	90					
5,0			C			100							D	D	D	90	90	90			95					
8,0													D	D	D	95	95	95								
12,0													D	D	D	95	95	95								
20,0													C	C												
30,0														C	C											

**Table B-7 Installation Type 1, DN ≥ 300. Ground water level to ground level**  
Minimum Backfill Compaction, % Standard Proctor Density. (D = uncompacted (dumped), C = Compacted)



Type 1 DN ≥ 300		Traffic Load AASHTO HS 20 - No Internal Vacuum - Ground Water Level to Ground Level																									
Backfill	Pipe SN	Standard Trench, B <sub>d</sub> /D = 1.8												Wide Trench, B <sub>d</sub> /D = 3.0										← Native Soil			
		SC I			SC II			SC III			SC IV			SC I			SC II			SC III			SC IV				
Burial Depth, m		2500	5000	10000	2500	5000	10000	2500	5000	10000	2500	5000	10000	2500	5000	10000	2500	5000	10000	2500	5000	10000	2500	5000	10000		
		1,0	D	D	D	85	85	85	90	85	85				95	95		D	D	D	85	85	85	90	90	85	
1,5	D	D	D	85	85	85	85	85	85	85	95	95	95			D	D	D	85	85	85	90	85	85			95
2,0	D	D	D	85	85	85	85	85	85	85	95	95	95			D	D	D	85	85	85	90	90	85			95
3,0	D	D	D	85	85	85	90	85	85					95		D	D	D	85	85	85	90	90	90			
5,0	D	D	D	85	85	85	90	90	90							D	D	D	90	90	85	95	95	95			
8,0	D	D	D	90	90	90	95	95	95							D	D	D	90	90	90	95	95	95			
12,0	D	D	D	90	90	90	95	95	95							D	D	D	90	90	90						
20,0	D	D	D	95	90	90										D	D	D	95	95	95						
30,0	C	D	D	100	95	95										C	D	D	100	95	95						
1,0	D	D	D	85	85	85	90	85	85					95	95	D	D	D	85	85	85	90	90	85			95
1,5	D	D	D	85	85	85	85	85	85	85	95	95	95			D	D	D	85	85	85	90	85	85			95
2,0	D	D	D	85	85	85	85	85	85	85	95	95	95			D	D	D	85	85	85	90	90	85			95
3,0	D	D	D	85	85	85	90	85	85					95		D	D	D	85	85	85	90	90	90			
5,0	D	D	D	85	85	85	90	90	90							D	D	D	90	90	85	95	95	95			
8,0	D	D	D	90	90	90	95	95	95							D	D	D	90	90	90	95	95	95			
12,0	D	D	D	90	90	90	95	95	95							D	D	D	90	90	90						
20,0	D	D	D	95	95	95										D	D	D	95	95	95						
30,0		C	C		100	100										C	D	D	100	95	95						
1,0	D	D	D	85	85	85	90	85	85					95	95	D	D	D	85	85	85	90	90	85			95
1,5	D	D	D	85	85	85	85	85	85	85	95	95	95			D	D	D	85	85	85	90	85	85			95
2,0	D	D	D	85	85	85	85	85	85	85	95	95	95			D	D	D	85	85	85	90	90	85			95
3,0	D	D	D	85	85	85	90	85	85					95		D	D	D	85	85	85	90	90	90			
5,0	D	D	D	85	85	85	90	90	90							D	D	D	90	90	90	95	95	95			
8,0	D	D	D	90	90	90	95	95	95							D	D	D	90	90	90						
12,0	D	D	D	95	95	90										D	D	D	95	90	90						
20,0		C	C		100	100										D	D	D	95	95	95						
30,0																C	C	C	100	100	100						
1,0	D	D	D	85	85	85	90	85	85					95	95	D	D	D	85	85	85	90	90	85			95
1,5	D	D	D	85	85	85	85	85	85	85	95	95	95			D	D	D	85	85	85	90	90	85			95
2,0	D	D	D	85	85	85	85	85	85	85	95	95	95			D	D	D	85	85	85	90	90	85			95
3,0	D	D	D	85	85	85	90	90	85					95		D	D	D	85	85	85	90	90	90			
5,0	D	D	D	90	90	85	95	95	95							D	D	D	90	90	90	95	95	95			
8,0	D	D	D	95	95	90										D	D	D	90	90	90						
12,0	C	C	C	100	100	100										D	D	D	95	95	95						
20,0																C	D	D	100	95	95						
30,0																	C	C		100	100						
1,0	D	D	D	90	85	85			95	90						D	D	D	85	85	85	95	90	90			
1,5	D	D	D	90	85	85	95	90	85					95		D	D	D	85	85	85	90	90	85			95
2,0	D	D	D	90	85	85	95	90	85					95		D	D	D	85	85	85	90	90	85			95
3,0	D	D	D	90	90	85			95	90						D	D	D	90	90	85	95	95	90			
5,0	D	D	D	95	95	95										D	D	D	90	90	90	95	95	95			
8,0			C			100										D	D	D	95	90	90						
12,0																D	D	D	95	95	95						
20,0																C	C	C	100	100	100						
30,0																	C	C		100	100						
1,0	D	D	D	95	95	90										D	D	D	90	90	85	95	95	90			
1,5	D	D	D	95	90	90			95							D	D	D	90	85	85	95	95	90			
2,0	D	D	D	95	95	90			95							D	D	D	90	90	85	95	95	90			
3,0	D	D	D	95	95	95										D	D	D	90	90	85	95	95	95			
5,0			C			100										D	D	D	90	90	90			95			
8,0																D	D	D	95	95	95						
12,0																D	D	D	95	95	95						
20,0																C	C		100	100							
30,0																	C	C		100	100						

**Table B-8 Installation Type 1, DN ≥ 300. Traffic Load – ground water level to ground level**  
 Minimum Backfill Compaction, % Standard Proctor Density. (D = uncompacted (dumped), C = Compacted)

01  
02  
03  
04  
05  
06  
07  
08  
09  
10  
app.

01  
02  
03  
04  
05  
06  
07  
08  
09  
10

app.

Type 1 DN ≥ 300		No Traffic Load - 1 bar Internal Vacuum - Ground Water To Level																				<= Native Soil			
Backfill	Pipe SN	Standard Trench, B <sub>d</sub> /D = 1.8												Wide Trench, B <sub>d</sub> /D = 3.0											
		SC I			SC II			SC III			SC IV			SC I			SC II			SC III			SC IV		
Burial Depth, m		2500	5000	10000	2500	5000	10000	2500	5000	10000	2500	5000	10000	2500	5000	10000	2500	5000	10000	2500	5000	10000	2500	5000	10000
1,0	D	D	D	85	85	85	90	85	85				95	D	D	D	90	85	85	95	90	85			
1,5	D	D	D	85	85	85	90	90	85				95	D	D	D	90	85	85	95	90	90			
2,0	D	D	D	85	85	85	90	90	85				95	D	D	D	90	85	85	95	90	90			
3,0	D	D	D	90	85	85	95	90	90					D	D	D	90	90	85	95	95	90			
5,0	D	D	D	90	90	85	95	95	90					D	D	D	90	90	90	95	95	95			
8,0	D	D	D	90	90	90	95	95	95					D	D	D	90	90	90		95	95			
12,0	D	D	D	90	90	90		95	95					D	D	D	95	90	90						
20,0	C	D	D	100	95	90								C	D	D	100	95	95						
30,0		C	D		100	95								C	C	D	100	100	95						
1,0	D	D	D	85	85	85	90	85	85				95	D	D	D	90	85	85	95	90	85			
1,5	D	D	D	85	85	85	90	90	85				95	D	D	D	90	85	85	95	90	90			
2,0	D	D	D	85	85	85	90	90	85				95	D	D	D	90	85	85	95	90	90			
3,0	D	D	D	90	85	85	95	90	90					D	D	D	90	90	85	95	95	90			
5,0	D	D	D	90	90	85	95	95	90					D	D	D	90	90	90	95	95	95			
8,0	D	D	D	90	90	90		95	95					D	D	D	95	90	90			95			
12,0	D	D	D	95	90	90			95					D	D	D	95	95	90						
20,0		D	D		95	95								C	D	D	100	95	95						
30,0			C			100									C	D		100	95						
1,0	D	D	D	85	85	85	90	85	85				95	D	D	D	90	85	85	95	90	85			
1,5	D	D	D	85	85	85	90	90	85				95	D	D	D	90	85	85	95	90	90			
2,0	D	D	D	85	85	85	90	90	85				95	D	D	D	90	85	85	95	90	90			
3,0	D	D	D	90	85	85	95	90	90					D	D	D	90	90	85	95	95	90			
5,0	D	D	D	90	90	85	95	95	90					D	D	D	90	90	90		95	95			
8,0	D	D	D	95	90	90		95	95					D	D	D	95	90	90			95			
12,0	C	D	D	100	95	90								D	D	D	95	95	90						
20,0			C			100								C	D	D	100	95	95						
30,0															C	C		100	100						
1,0	D	D	D	90	85	85	95	90	85				95	D	D	D	90	85	85	95	95	90			
1,5	D	D	D	90	85	85	95	90	85				95	D	D	D	90	90	85	95	95	90			
2,0	D	D	D	90	85	85	95	90	85				95	D	D	D	90	90	85	95	95	90			
3,0	D	D	D	90	90	85	95	95	90					D	D	D	90	90	85	95	95	90			
5,0	D	D	D	95	90	90		95	95					D	D	D	90	90	90		95	95			
8,0		D	D		95	90								D	D	D	95	90	90			95			
12,0			C	C		100	100							D	D	D	95	95	95						
20,0														C	C	D	100	100	95						
30,0																C	C		100	100					
1,0		D	D		95	95								D	D	D	90	90	90		95	95			
1,5		C	D		100	95								D	D	D	90	90	90		95	95			
2,0		C	D		100	95								D	D	D	90	90	90		95	95			
3,0			D			95								D	D	D	95	90	90			95			
5,0														D	D	D	95	90	90			95			
8,0														D	D	D	95	95	90						
12,0														C	D	D	100	95	95						
20,0															C	C	D	100	100	95					
30,0																C			100						

Group 1  
Group 2  
Group 3  
Group 4  
Group 5  
Group 6

**Table B-9 Installation Type 1, DN ≥ 300. Vacuum 1.0 bar – Ground Water Level to Ground Level**  
Minimum Backfill Compaction, % Standard Proctor Density. (D = uncompacted (dumped), C = Compacted)



01  
02  
03  
04  
05  
06  
07  
08  
09  
10  
app.

Type 1 DN ≤ 250	No Traffic Load No Internal Vacuum Ground Water Level to Ground Level								Traffic, AASHTO HS 20 No Internal Vacuum Ground Water Level to Ground Level								No Traffic Load 1 bar Internal Vacuum Ground Water Level to Ground Level								Native Soil					
	B <sub>d</sub> /D = 3.0				B <sub>d</sub> /D ≥ 5.0				B <sub>d</sub> /D = 3.0				B <sub>d</sub> /D ≥ 5.0				B <sub>d</sub> /D = 3.0				B <sub>d</sub> /D ≥ 5.0									
	SCI	SCII	SCIII	SCIV	SCI	SCII	SCIII	SCIV	SCI	SCII	SCIII	SCIV	SCI	SCII	SCIII	SCIV	SCI	SCII	SCIII	SCIV	SCI	SCII	SCIII	SCIV		SCI	SCII	SCIII	SCIV	
Pipe SN	10000	10000	10000	10000	10000	10000	10000	10000	10000	10000	10000	10000	10000	10000	10000	10000	10000	10000	10000	10000	10000	10000	10000	10000	10000	10000	10000	10000	<= Native Soil	
Burial Depth, m	10000	10000	10000	10000	10000	10000	10000	10000	10000	10000	10000	10000	10000	10000	10000	10000	10000	10000	10000	10000	10000	10000	10000	10000	10000	10000	10000	10000		
1,0	D	85	85	95	D	85	85	95	D	85	90		D	85	90		D	85	85		D	85	85	D	85	85	90	Group 1		
1,5	D	85	85	95	D	85	85	95	D	85	85		D	85	85		D	85	90		D	85	90	D	85	90	90			
	D	85	85	95	D	85	85	95	D	85	90		D	85	90		D	85	90		D	85	90	D	85	90	90			
3,0	D	85	90		D	85	90		D	85	90		D	85	90		D	85	90		D	85	90	D	85	90	90			
5,0	D	90	95		D	90	95		D	90	95		D	90	95		D	90	95		D	90	95	D	90	95	95			
8,0	D	90	95		D	90		D	90	95		D	90		D	90		D	90	95		D	90	95	D	90				95
12,0	D	90			D	95		D	90		D	95		D	95		D	95		D	95		D	95	D	95				95
20,0	D	95			D	95		D	95		D	95		D	95		D	95		D	95		D	95	D	95				95
30,0	C	100			C	100		C	100		C	100		C	100		C	100		C	100		C	100	C	100				100
1,0	D	85	85	95	D	85	85	95	D	85	90		D	85	90		D	85	85		D	85	85	D	85	85	90			Group 2
1,5	D	85	85	95	D	85	85	95	D	85	85		D	85	85		D	85	90		D	85	90	D	85	90	90			
2,0	D	85	85	95	D	85	85	95	D	85	90		D	85	90		D	85	90		D	85	90	D	85	90	90			
3,0	D	85	90		D	85	90		D	85	90		D	85	90		D	85	90		D	85	90	D	85	90	90			
5,0	D	90	95		D	90	95		D	90	95		D	90	95		D	90	95		D	90	95	D	90	95	95			
8,0	D	90			D	90		D	90		D	90		D	90		D	90		D	90		D	90	D	90		95		
12,0	D	95			D	95		D	95		D	95		D	95		D	95		D	95		D	95	D	95		95		
20,0	D	95			D	95		D	95		D	95		D	95		D	95		D	95		D	95	D	95		95		
30,0	C	100			C	100		C	100		C	100		C	100		C	100		C	100		C	100	C	100		100		
1,0	D	85	85	95	D	85	85	95	D	85	90		D	85	90		D	85	85		D	85	85	D	85	85	90	Group 3		
1,5	D	85	85	95	D	85	85	95	D	85	85		D	85	85		D	85	90		D	85	90	D	85	90	90			
2,0	D	85	85	95	D	85	85	95	D	85	90		D	85	90		D	85	90		D	85	90	D	85	90	90			
3,0	D	85	90		D	85	90		D	85	90		D	85	90		D	85	90		D	85	90	D	85	90	90			
5,0	D	90	95		D	90	95		D	90	95		D	90	95		D	90	95		D	90	95	D	90	95	95			
8,0	D	90			D	90		D	90		D	90		D	90		D	90		D	90		D	90	D	90				95
12,0	D	95			D	95		D	95		D	95		D	95		D	95		D	95		D	95	D	95				95
20,0	D	95			D	95		D	95		D	95		D	95		D	95		D	95		D	95	D	95				95
30,0	C	100			C	100		C	100		C	100		C	100		C	100		C	100		C	100	C	100				100
1,0	D	85	85	95	D	85	85	95	D	85	90		D	85	90		D	85	90		D	85	90	D	85	90	90			Group 4
1,5	D	85	85	95	D	85	85	95	D	85	85		D	85	85		D	85	90		D	85	90	D	85	90	90			
2,0	D	85	85	95	D	85	85	95	D	85	90		D	85	90		D	85	90		D	85	90	D	85	90	90			
3,0	D	85	90		D	85	90		D	85	90		D	85	90		D	85	90		D	85	90	D	85	90	90			
5,0	D	90	95		D	90	95		D	90	95		D	90	95		D	90	95		D	90	95	D	90	95	95			
8,0	D	90			D	90		D	90		D	90		D	90		D	90		D	90		D	90	D	90		95		
12,0	D	95			D	95		D	95		D	95		D	95		D	95		D	95		D	95	D	95		95		
20,0	C	100			D	95		C	100		D	95		D	95		C	100		D	95		D	95	D	95		95		
30,0	C	100			C	100		C	100		C	100		C	100		C	100		C	100		C	100	C	100		100		
1,0	D	85	85	95	D	85	85	95	D	90	95		D	85	90		D	90	90		D	90	90	D	85	90	90	Group 5		
1,5	D	85	85	95	D	85	85	95	D	85	90		D	85	90		D	90	95		D	90	95	D	85	90	90			
2,0	D	85	85	95	D	85	85	95	D	85	90		D	85	90		D	90	95		D	90	95	D	85	90	90			
3,0	D	85	90		D	85	90		D	90	95		D	85	90		D	90	95		D	90	95	D	85	90	90			
5,0	D	90	95		D	90	95		D	90	95		D	85	90		D	90	95		D	90	95	D	85	90	90			
8,0	D	95			D	90		D	95		D	95		D	90		D	95		D	95		D	95	D	90			95	
12,0	D	95			D	95		D	95		D	95		D	95		D	95		D	95		D	95	D	95			95	
20,0	C	100			D	95		C	100		D	95		D	95		C	100		D	95		D	95	D	95			95	
30,0					C	100								C	100					D	95		D	95	D	95			95	
1,0	D	85	85	95	D	85	85	95	D	90	95		D	85	90		D	90	90		D	90	90	D	85	90	90		Group 6	
1,5	D	85	85	95	D	85	85	95	D	85	90		D	85	90		D	90	95		D	90	95	D	85	90	90			
2,0	D	85	85		D	85	85	95	D	85	90		D	85	90		D	90	95		D	90	95	D	85	90	90			
3,0	D	90	95		D	85	90		D	90	95		D	85	90		D	90	95		D	90	95	D	85	90	90			
5,0	D	90			D	90	95		D	90		D	90	95		D	90		D	90	95		D	90	95	D	85	90		90
8,0	D	95			D	90		D	95		D	95		D	90		D	95		D	95		D	95	D	90		95		
12,0	C	100			D	95		C	100		D	95		D	95		C	100		D	95		D	95	D	95		95		
20,0					D	95								D	95					D	95		D	95	D	95		95		
30,0					D	95								D	95					D	95		D	95	D	95		95		

**Table B-11 Installation Type 1, DN ≤ 250. Ground water level to ground level**  
Minimum Backfill Compaction, % Standard Proctor Density. (D = uncompacted (dumped), C = Compacted)

Type 2 DN ≥ 300		No Traffic Load – No Internal Vacuum – Ground Water Level below Pipe Invert																								<= Native Soil
		Standard Trench, B <sub>d</sub> /D = 1.8												Wide Trench, B <sub>d</sub> /D = 3.0												
Upper Backfill		SC III 85% SPD						SC III, 85% SPD or SC IV, 90% SPD						SC III 85% SPD						SC III, 85% SPD or SC IV, 90% SPD						
Backfill		SC I			SC II			SC III			SC IV			SC I			SC II			SC III			SC IV			
Pipe SN	Burial Depth, m	2500	5000	10000	2500	5000	10000	2500	5000	10000	2500	5000	10000	2500	5000	10000	2500	5000	10000	2500	5000	10000	2500	5000	10000	
	1,0	D	D	D	90	90	90	D	D	D	85	85	85	D	D	D	90	90	90	D	D	D	85	85	85	
	1,5	D	D	D	90	90	90	D	D	D	85	85	85	D	D	D	90	90	90	D	D	D	85	85	85	
	2,0	D	D	D	90	90	90	D	D	D	85	85	85	D	D	D	90	90	90	D	D	D	85	85	85	
	3,0	D	D	D	90	90	90	D	D	D	85	85	85	D	D	D	90	90	90	D	D	D	85	85	85	
	5,0	D	D	D	90	90	90	D	D	D	85	85	85	D	D	D	90	90	90	D	D	D	85	85	85	
	8,0	D	D	D	90	90	90	D	D	D	85	85	85	D	D	D	90	90	90	D	D	D	90	90	90	
	12,0	D	D	D	90	90	90							D	D		90	90								
	20,0		D	D		90	90											D		95						
	1,0	D	D	D	90	90	90	D	D	D	85	85	85	D	D	D	90	90	90	D	D	D	85	85	85	
	1,5	D	D	D	90	90	90	D	D	D	85	85	85	D	D	D	90	90	90	D	D	D	85	85	85	
	2,0	D	D	D	90	90	90	D	D	D	85	85	85	D	D	D	90	90	90	D	D	D	85	85	85	
	3,0	D	D	D	90	90	90	D	D	D	85	85	85	D	D	D	90	90	90	D	D	D	85	85	85	
	5,0	D	D	D	90	90	90	D	D	D	85	85	85	D	D	D	90	90	90	D	D	D	85	85	85	
	8,0	D	D	D	90	90	90	D	D	D	85	85	85	D	D	D	90	90	90	D	D	D	90	90	90	
	12,0	D	D	D	90	90	90							D	D		90	90								
	20,0			D			95																			
	1,0	D	D	D	90	90	90	D	D	D	85	85	85	D	D	D	90	90	90	D	D	D	85	85	85	
	1,5	D	D	D	90	90	90	D	D	D	85	85	85	D	D	D	90	90	90	D	D	D	85	85	85	
	2,0	D	D	D	90	90	90	D	D	D	85	85	85	D	D	D	90	90	90	D	D	D	85	85	85	
	3,0	D	D	D	90	90	90	D	D	D	85	85	85	D	D	D	90	90	90	D	D	D	85	85	85	
	5,0	D	D	D	90	90	90	D	D	D	85	85	85	D	D	D	90	90	90	D	D	D	90	85	85	
	8,0	D	D	D	90	90	90	D	D	D	90	90	90	D	D	D	90	90	90		D	D		90	90	
	12,0		D	D		90	90							D	D		90	90								
	20,0																									
	1,0	D	D	D	90	90	90	D	D	D	85	85	85	D	D	D	90	90	90	D	D	D	85	85	85	
	1,5	D	D	D	90	90	90	D	D	D	85	85	85	D	D	D	90	90	90	D	D	D	85	85	85	
	2,0	D	D	D	90	90	90	D	D	D	85	85	85	D	D	D	90	90	90	D	D	D	85	85	85	
	3,0	D	D	D	90	90	90	D	D	D	90	90	85	D	D	D	90	90	90	D	D	D	85	85	85	
	5,0	D	D	D	90	90	90	D	D	D	90	85	85	D	D	D	90	90	90	D	D	D	90	90	85	
	8,0	D	D	D	95	95	90		D	D		95	95	D	D	D	90	90	90		D			90	90	
	12,0			C			100							D	D		95	95								
	20,0																									
	1,0	D	D	D	90	90	90	D	D	D	85	85	85	D	D	D	90	90	90	D	D	D	85	85	85	
	1,5	D	D	D	90	90	90	D	D	D	85	85	85	D	D	D	90	90	90	D	D	D	85	85	85	
	2,0	D	D	D	90	90	90	D	D	D	85	85	85	D	D	D	90	90	90	D	D	D	85	85	85	
	3,0	D	D	D	90	90	90	D	D	D	90	90	85	D	D	D	90	90	90	D	D	D	85	85	85	
	5,0	C	D	D	100	95	95		D	D		95	95	D	D	D	90	90	90	D	D	D	90	90	90	
	8,0														D	D		90	90			D			90	
	12,0															D		95	95							
	20,0																									
	1,0	D	D	D	90	90	90	D	D	D	85	85	85	D	D	D	90	90	90	D	D	D	85	85	85	
	1,5	D	D	D	90	90	90	D	D	D	90	85	85	D	D	D	90	90	90	D	D	D	85	85	85	
	2,0	D	D	D	90	90	90	D	D	D	90	90	85	D	D	D	90	90	90	D	D	D	85	85	85	
	3,0	C	D	D	100	95	90		D	D		95	90	D	D	D	90	90	90	D	D	D	90	85	85	
	5,0													D	D	D	90	90	90		D	D		90	90	
	8,0														D	D		95	95							
	12,0																									
	20,0																									

- 01
- 02
- 03
- 04
- 05
- 06
- 07
- 08
- 09
- 10
- app.

**Table B–12 Installation Type 2, DN ≥ 300. No Vacuum - ground water level below pipe invert**  
 Minimum Backfill Compaction, % Standard Proctor Density. (D = uncompacted (dumped), C = Compacted)

01 02 03 04 05 06 07 08 09 10 app.	Type 2 DN ≥ 300																										Native Soil =<
	No Traffic Load – 0.5 bar Internal Vacuum – Ground Water Level below Pipe Invert																										
	Standard Trench, B <sub>d</sub> /D = 1.8													Wide Trench, B <sub>d</sub> /D = 3.0													
	Upper Backfill			SC III 85% SPD						SC III, 85% SPD or SC IV, 90% SPD						SC III 85% SPD						SC III, 85% SPD or SC IV, 90% SPD					
Backfill			SC I			SC II			SC III			SC IV			SC I			SC II			SC III			SC IV			
Pipe SN			2500	5000	10000	2500	5000	10000	2500	5000	10000	2500	5000	10000	2500	5000	10000	2500	5000	10000	2500	5000	10000	2500	5000	10000	
Burial Depth, m			2500	5000	10000	2500	5000	10000	2500	5000	10000	2500	5000	10000	2500	5000	10000	2500	5000	10000	2500	5000	10000	2500	5000	10000	
1,0	D	D	D	90	90	90	D	D	D	85	85	85	D	D	D	90	90	90	D	D	D	85	85	85			
1,5	D	D	D	90	90	90	D	D	D	85	85	85	D	D	D	90	90	90	D	D	D	85	85	85			
2,0	D	D	D	90	90	90	D	D	D	85	85	85	D	D	D	90	90	90	D	D	D	85	85	85			
3,0	D	D	D	90	90	90	D	D	D	85	85	85	D	D	D	90	90	90	D	D	D	85	85	85			
5,0	D	D	D	90	90	90	D	D	D	85	85	85	D	D	D	90	90	90	D	D	D	85	85	85			
8,0	D	D	D	90	90	90	D	D	D	85	85	85	D	D	D	90	90	90	D	D	D	85	85	85			
12,0	D	D	D	90	90	90	D	D	D	85	85	85	D	D	D	90	90	90	D	D	D	85	85	85			
20,0	D	D	D	90	90	90	D	D	D	85	85	85	D	D	D	90	90	90	D	D	D	85	85	85			
1,0	D	D	D	90	90	90	D	D	D	85	85	85	D	D	D	90	90	90	D	D	D	85	85	85			
1,5	D	D	D	90	90	90	D	D	D	85	85	85	D	D	D	90	90	90	D	D	D	85	85	85			
2,0	D	D	D	90	90	90	D	D	D	85	85	85	D	D	D	90	90	90	D	D	D	85	85	85			
3,0	D	D	D	90	90	90	D	D	D	85	85	85	D	D	D	90	90	90	D	D	D	85	85	85			
5,0	D	D	D	90	90	90	D	D	D	85	85	85	D	D	D	90	90	90	D	D	D	85	85	85			
8,0	D	D	D	90	90	90	D	D	D	85	85	85	D	D	D	90	90	90	D	D	D	85	85	85			
12,0	D	D	D	90	90	90	D	D	D	85	85	85	D	D	D	90	90	90	D	D	D	85	85	85			
20,0	D	D	D	90	90	90	D	D	D	85	85	85	D	D	D	90	90	90	D	D	D	85	85	85			
1,0	D	D	D	90	90	90	D	D	D	85	85	85	D	D	D	90	90	90	D	D	D	85	85	85			
1,5	D	D	D	90	90	90	D	D	D	85	85	85	D	D	D	90	90	90	D	D	D	85	85	85			
2,0	D	D	D	90	90	90	D	D	D	85	85	85	D	D	D	90	90	90	D	D	D	85	85	85			
3,0	D	D	D	90	90	90	D	D	D	85	85	85	D	D	D	90	90	90	D	D	D	85	85	85			
5,0	D	D	D	90	90	90	D	D	D	85	85	85	D	D	D	90	90	90	D	D	D	85	85	85			
8,0	D	D	D	90	90	90	D	D	D	85	85	85	D	D	D	90	90	90	D	D	D	85	85	85			
12,0	D	D	D	90	90	90	D	D	D	85	85	85	D	D	D	90	90	90	D	D	D	85	85	85			
20,0	D	D	D	90	90	90	D	D	D	85	85	85	D	D	D	90	90	90	D	D	D	85	85	85			
1,0	D	D	D	90	90	90	D	D	D	85	85	85	D	D	D	90	90	90	D	D	D	85	85	85			
1,5	D	D	D	90	90	90	D	D	D	85	85	85	D	D	D	90	90	90	D	D	D	85	85	85			
2,0	D	D	D	90	90	90	D	D	D	85	85	85	D	D	D	90	90	90	D	D	D	85	85	85			
3,0	D	D	D	90	90	90	D	D	D	85	85	85	D	D	D	90	90	90	D	D	D	85	85	85			
5,0	D	D	D	90	90	90	D	D	D	85	85	85	D	D	D	90	90	90	D	D	D	85	85	85			
8,0	D	D	D	90	90	90	D	D	D	85	85	85	D	D	D	90	90	90	D	D	D	85	85	85			
12,0	D	D	D	90	90	90	D	D	D	85	85	85	D	D	D	90	90	90	D	D	D	85	85	85			
20,0	D	D	D	90	90	90	D	D	D	85	85	85	D	D	D	90	90	90	D	D	D	85	85	85			
1,0	D	D	D	90	90	90	D	D	D	85	85	85	D	D	D	90	90	90	D	D	D	85	85	85			
1,5	D	D	D	90	90	90	D	D	D	85	85	85	D	D	D	90	90	90	D	D	D	85	85	85			
2,0	D	D	D	90	90	90	D	D	D	85	85	85	D	D	D	90	90	90	D	D	D	85	85	85			
3,0	D	D	D	90	90	90	D	D	D	85	85	85	D	D	D	90	90	90	D	D	D	85	85	85			
5,0	D	D	D	90	90	90	D	D	D	85	85	85	D	D	D	90	90	90	D	D	D	85	85	85			
8,0	D	D	D	90	90	90	D	D	D	85	85	85	D	D	D	90	90	90	D	D	D	85	85	85			
12,0	D	D	D	90	90	90	D	D	D	85	85	85	D	D	D	90	90	90	D	D	D	85	85	85			
20,0	D	D	D	90	90	90	D	D	D	85	85	85	D	D	D	90	90	90	D	D	D	85	85	85			
1,0	D	D	D	90	90	90	D	D	D	85	85	85	D	D	D	90	90	90	D	D	D	85	85	85			
1,5	D	D	D	90	90	90	D	D	D	85	85	85	D	D	D	90	90	90	D	D	D	85	85	85			
2,0	D	D	D	90	90	90	D	D	D	85	85	85	D	D	D	90	90	90	D	D	D	85	85	85			
3,0	D	D	D	90	90	90	D	D	D	85	85	85	D	D	D	90	90	90	D	D	D	85	85	85			
5,0	D	D	D	90	90	90	D	D	D	85	85	85	D	D	D	90	90	90	D	D	D	85	85	85			
8,0	D	D	D	90	90	90	D	D	D	85	85	85	D	D	D	90	90	90	D	D	D	85	85	85			
12,0	D	D	D	90	90	90	D	D	D	85	85	85	D	D	D	90	90	90	D	D	D	85	85	85			
20,0	D	D	D	90	90	90	D	D	D	85	85	85	D	D	D	90	90	90	D	D	D	85	85	85			
1,0	D	D	D	90	90	90	D	D	D	85	85	85	D	D	D	90	90	90	D	D	D	85	85	85			
1,5	D	D	D	90	90	90	D	D	D	85	85	85	D	D	D	90	90	90	D	D	D	85	85	85			
2,0	D	D	D	90	90	90	D	D	D	85	85	85	D	D	D	90	90	90	D	D	D	85	85	85			
3,0	D	D	D	90	90	90	D	D	D	85	85	85	D	D	D	90	90	90	D	D	D	85	85	85			
5,0	D	D	D	90	90	90	D	D	D	85	85	85	D	D	D	90	90	90	D	D	D	85	85	85			
8,0	D	D	D	90	90	90	D	D	D	85	85	85	D	D	D	90	90	90	D	D	D	85	85	85			
12,0	D	D	D	90	90	90	D	D	D	85	85	85	D	D	D	90	90	90	D	D	D	85	85	85			
20,0	D	D	D	90	90	90	D	D	D	85	85	85	D	D	D	90	90	90	D	D	D	85	85	85			

**Table B-13 Installation Type 2, DN ≥ 300. 0.5 bar Vacuum - Ground water level below pipe invert**  
 Minimum Backfill Compaction, % Standard Proctor Density. (D = uncompacted (dumped), C = Compacted)

Type 2 DN ≥ 300		No Traffic Load – 1.0 bar Internal Vacuum – Ground Water Level below Pipe Invert																								
		Standard Trench, B <sub>d</sub> /D = 1.8												Wide Trench, B <sub>d</sub> /D = 3.0												
Upper Backfill		SC III 85% SPD						SC III, 85% SPD or SC IV, 90% SPD						SC III 85% SPD						SC III, 85% SPD or SC IV, 90% SPD						<= Native Soil
Backfill		SC I			SC II			SC III			SC IV			SC I			SC II			SC III			SC IV			
Pipe SN	2500	5000	10000	2500	5000	10000	2500	5000	10000	2500	5000	10000	2500	5000	10000	2500	5000	10000	2500	5000	10000	2500	5000	10000		
Burial Depth, m	2500	5000	10000	2500	5000	10000	2500	5000	10000	2500	5000	10000	2500	5000	10000	2500	5000	10000	2500	5000	10000	2500	5000	10000		
1,0	D	D	D	90	90	90	D	D	D	85	85	85	D	D	D	90	90	90		D	D		85	85		
1,5	D	D	D	90	90	90	D	D	D	85	85	85	D	D	D	90	90	90		D	D		85	85		
2,0	D	D	D	90	90	90	D	D	D	85	85	85	D	D	D	90	90	90		D	D		85	85		
3,0	D	D	D	90	90	90		D	D		85	85	D	D	D	90	90	90			D			85		
5,0	D	D	D	90	90	90		D	D		85	85	D	D	D	90	90	90			D			85		
8,0	D	D	D	90	90	90			D			85		D	D		90	90								
12,0		D	D		90	90									D			90								
20,0			D			90																				
1,0	D	D	D	90	90	90	D	D	D	85	85	85	D	D	D	90	90	90		D	D		85	85		
1,5	D	D	D	90	90	90	D	D	D	85	85	85	D	D	D	90	90	90		D	D		85	85		
2,0	D	D	D	90	90	90	D	D	D	85	85	85	D	D	D	90	90	90		D	D		85	85		
3,0	D	D	D	90	90	90		D	D		85	85	D	D	D	90	90	90			D			85		
5,0	D	D	D	90	90	90		D	D		85	85	D	D	D	90	90	90			D			85		
8,0	D	D	D	90	90	90			D			85		D	D		90	90								
12,0		D	D		90	90									D			90								
20,0																										
1,0	D	D	D	90	90	90	D	D	D	85	85	85	D	D	D	90	90	90		D	D		85	85		
1,5	D	D	D	90	90	90	D	D	D	85	85	85	D	D	D	90	90	90		D	D		85	85		
2,0	D	D	D	90	90	90	D	D	D	85	85	85	D	D	D	90	90	90		D	D		85	85		
3,0	D	D	D	90	90	90		D	D		85	85	D	D	D	90	90	90			D			85		
5,0	D	D	D	90	90	90			D			85		D	D		90	90			D			85		
8,0		D	D		90	90			D			90			D			90								
12,0			D			90																				
20,0																										
1,0	D	D	D	90	90	90		D	D		85	85	D	D	D	90	90	90		D	D		85	85		
1,5	D	D	D	90	90	90		D	D		85	85	D	D	D	90	90	90			D			85		
2,0	D	D	D	90	90	90		D	D		85	85	D	D	D	90	90	90			D			85		
3,0	D	D	D	90	90	90		D	D		85	85	D	D	D	90	90	90			D			85		
5,0		D	D		90	90			D			85		D	D		90	90								
8,0			D			90									D			90								
12,0																										
20,0																										
1,0		D	D		90	90			D			85	D	D	D	90	90	90			D			85		
1,5			D			90							D	D	D	90	90	90			D			85		
2,0			D			90							D	D	D	90	90	90			D			85		
3,0			D			90								D	D		90	90								
5,0															D			90								
8,0																										
12,0																										
20,0																										
1,0														D	D		90	90								
1,5														D	D		90	90								
2,0														D	D		90	90								
3,0															D			90								
5,0																										
8,0																										
12,0																										
20,0																										

- 01
- 02
- 03
- 04
- 05
- 06
- 07
- 08
- 09
- 10
- app.

**Table B-14 Installation Type 2, DN ≥ 300. 1.0 bar Vacuum - ground water level below pipe invert**  
 Minimum Backfill Compaction, % Standard Proctor Density. (D = uncompacted (dumped), C = Compacted)

01  
02  
03  
04  
05  
06  
07  
08  
09  
10

Type 2 DN ≥ 300		No Traffic Load – No Internal Vacuum – Ground Water Level to Ground Level																								
		Standard Trench, B <sub>d</sub> /D = 1.8												Wide Trench, B <sub>d</sub> /D = 3.0												
Upper Backfill		SC III 85% SPD						SC III, 85% SPD or SC IV, 90% SPD						SC III 85% SPD						SC III, 85% SPD or SC IV, 90% SPD						Native Soil
Backfill		SC I			SC II			SC III			SC IV			SC I			SC II			SC III			SC IV			
Pipe SN	Burial Depth, m	2500	5000	10000	2500	5000	10000	2500	5000	10000	2500	5000	10000	2500	5000	10000	2500	5000	10000	2500	5000	10000	2500	5000	10000	
	1,0	D	D	D	90	90	90	D	D	D	85	85	85	D	D	D	90	90	90	D	D	D	85	85	85	
	1,5	D	D	D	90	90	90	D	D	D	85	85	85	D	D	D	90	90	90	D	D	D	85	85	85	
	2,0	D	D	D	90	90	90	D	D	D	85	85	85	D	D	D	90	90	90	D	D	D	85	85	85	
	3,0	D	D	D	90	90	90	D	D	D	85	85	85	D	D	D	90	90	90	D	D	D	85	85	85	
	5,0	D	D	D	85	85	85		D	D		85	85	D	D	D	90	90	85			D			90	
	8,0		D	D		90	90									D		90								
	12,0																									
	20,0																									
	1,0	D	D	D	90	90	90	D	D	D	85	85	85	D	D	D	90	90	90	D	D	D	85	85	85	
	1,5	D	D	D	90	90	90	D	D	D	85	85	85	D	D	D	90	90	90	D	D	D	85	85	85	
	2,0	D	D	D	90	90	90	D	D	D	85	85	85	D	D	D	90	90	90	D	D	D	85	85	85	
	3,0	D	D	D	90	90	90	D	D	D	85	85	85	D	D	D	90	90	90	D	D	D	85	85	85	
	5,0	D	D	D	85	85	85		D	D		85	85	D	D	D	90	90	85			D			90	
	8,0		D	D		90	90									D		90								
	12,0																									
	20,0																									
	1,0	D	D	D	90	90	90	D	D	D	85	85	85	D	D	D	90	90	90	D	D	D	85	85	85	
	1,5	D	D	D	90	90	90	D	D	D	85	85	85	D	D	D	90	90	90	D	D	D	85	85	85	
	2,0	D	D	D	90	90	90	D	D	D	85	85	85	D	D	D	90	90	90	D	D	D	85	85	85	
	3,0	D	D	D	90	90	90	D	D	D	85	85	85	D	D	D	90	90	90	D	D	D	85	85	85	
	5,0	D	D	D	85	85	85		D	D		85	85	D	D	D	90	90	85			D			90	
	8,0		D	D		90	90									D		90								
	12,0																									
	20,0																									
	1,0	D	D	D	90	90	90	D	D	D	85	85	85	D	D	D	90	90	90	D	D	D	85	85	85	
	1,5	D	D	D	90	90	90	D	D	D	85	85	85	D	D	D	90	90	90	D	D	D	85	85	85	
	2,0	D	D	D	90	90	90	D	D	D	85	85	85	D	D	D	90	90	90	D	D	D	85	85	85	
	3,0	D	D	D	90	90	90	D	D	D	85	85	85	D	D	D	90	90	90	D	D	D	85	85	85	
	5,0	D	D	D	90	90	85		D	D		90	90		D	D	90	90				D			90	
	8,0			D			95									D		90								
	12,0																									
	20,0																									
	1,0	D	D	D	90	90	90	D	D	D	85	85	85	D	D	D	90	90	90	D	D	D	85	85	85	
	1,5	D	D	D	90	90	90	D	D	D	85	85	85	D	D	D	90	90	90	D	D	D	85	85	85	
	2,0	D	D	D	90	90	90	D	D	D	85	85	85	D	D	D	90	90	90	D	D	D	85	85	85	
	3,0	D	D	D	90	90	90	D	D	D	90	90	85	D	D	D	90	90	90		D	D		90	85	
	5,0			D			95									D	D	90	90							
	8,0																									
	12,0																									
	20,0																									
	1,0	D	D	D	90	90	90	D	D	D	85	85	85	D	D	D	90	90	90	D	D	D	85	85	85	
	1,5	D	D	D	90	90	90	D	D	D	90	90	85	D	D	D	90	90	90	D	D	D	85	85	85	
	2,0	D	D	D	95	90	90		D	D		90	85	D	D	D	90	90	90	D	D	D	90	85	85	
	3,0			D			95							D	D	D	90	90	90		D	D		90	85	
	5,0															D		90								
	8,0																									
	12,0																									
	20,0																									

app.

**Table B–15 Installation Type 2, DN ≥ 300. No vacuum - ground water level to ground level**  
 Minimum Backfill Compaction, % Standard Proctor Density. (D = uncompacted (dumped), C = Compacted)



Type 2 DN ≥ 300		No Traffic Load – 0.5 bar Internal Vacuum – Ground Water Level to Ground Level																									
		Standard Trench, B <sub>d</sub> /D = 1.8												Wide Trench, B <sub>d</sub> /D = 3.0													
Upper Backfill		SC III 85% SPD						SC III, 85% SPD or SC IV, 90% SPD						SC III 85% SPD						SC III, 85% SPD or SC IV, 90% SPD						<= Native Soil	
Backfill		SC I			SC II			SC III			SC IV			SC I			SC II			SC III			SC IV				
Pipe SN	2500	5000	10000	2500	5000	10000	2500	5000	10000	2500	5000	10000	2500	5000	10000	2500	5000	10000	2500	5000	10000	2500	5000	10000	2500	5000	10000
Burial Depth, m	2500	5000	10000	2500	5000	10000	2500	5000	10000	2500	5000	10000	2500	5000	10000	2500	5000	10000	2500	5000	10000	2500	5000	10000	2500	5000	10000
1,0	D	D	D	90	90	90	D	D	D	85	85	85	D	D	D	90	90	90		D	D		85	85			
1,5	D	D	D	90	90	90	D	D	D	85	85	85	D	D	D	90	90	90		D	D		85	85			
2,0	D	D	D	90	90	90	D	D	D	85	85	85	D	D	D	90	90	90		D	D		85	85			
3,0	D	D	D	90	90	90		D	D		85	85	D	D	D	90	90	90			D				85		
5,0		D	D		85	85			D			85			D			85									
8,0			D			90																					
12,0																											
20,0																											
1,0	D	D	D	90	90	90	D	D	D	85	85	85	D	D	D	90	90	90		D	D		85	85			
1,5	D	D	D	90	90	90	D	D	D	85	85	85	D	D	D	90	90	90		D	D		85	85			
2,0	D	D	D	90	90	90	D	D	D	85	85	85	D	D	D	90	90	90		D	D		85	85			
3,0	D	D	D	90	90	90		D	D		85	85	D	D	D	90	90	90			D				85		
5,0		D	D		85	85			D			85			D			85									
8,0			D			90																					
12,0																											
20,0																											
1,0	D	D	D	90	90	90	D	D	D	85	85	85	D	D	D	90	90	90		D	D		85	85			
1,5	D	D	D	90	90	90	D	D	D	85	85	85	D	D	D	90	90	90		D	D		85	85			
2,0	D	D	D	90	90	90	D	D	D	85	85	85	D	D	D	90	90	90		D	D		85	85			
3,0	D	D	D	90	90	90		D	D		85	85	D	D	D	90	90	90			D				85		
5,0		D	D		85	85			D			85			D			85									
8,0			D			90																					
12,0																											
20,0																											
1,0	D	D	D	90	90	90		D	D		85	85	D	D	D	90	90	90		D	D		85	85			
1,5	D	D	D	90	90	90		D	D		85	85	D	D	D	90	90	90		D	D		85	85			
2,0	D	D	D	90	90	90		D	D		85	85	D	D	D	90	90	90			D				85		
3,0	D	D	D	90	90	90		D	D		85	85		D	D		90	90			D				85		
5,0			D			85						85			D			85									
8,0																											
12,0																											
20,0																											
1,0																											
1,5																											
2,0																											
3,0																											
5,0																											
8,0																											
12,0																											
20,0																											
1,0			D			90							D	D	D	90	90	90			D				85		
1,5														D	D		90	90			D				85		
2,0														D	D		90	90				D			85		
3,0															D			90	90						85		
5,0																											
8,0																											
12,0																											
20,0																											

- 01
- 02
- 03
- 04
- 05
- 06
- 07
- 08
- 09
- 10

app.

**Table B-16 Installation Type 2, DN ≥ 300. 0.5 bar Vacuum - ground water level to ground level**  
 Minimum Backfill Compaction, % Standard Proctor Density. (D = uncompacted (dumped), C = Compacted)

01  
02  
03  
04  
05  
06  
07  
08  
09  
10

app.

Type 2 DN ≥ 300		No Traffic Load – 1.0 bar Internal Vacuum – Ground Water Level to Ground Level																									<= Native Soil
		Standard Trench, B <sub>d</sub> /D = 1.8												Wide Trench, B <sub>d</sub> /D = 3.0													
Upper Backfill		SC III 85% SPD						SC III, 85% SPD or SC IV, 90% SPD						SC III 85% SPD						SC III, 85% SPD or SC IV, 90% SPD							
Backfill		SC I			SC II			SC III			SC IV			SC I			SC II			SC III			SC IV				
Pipe SN Burial Depth, m		2500	5000	10000	2500	5000	10000	2500	5000	10000	2500	5000	10000	2500	5000	10000	2500	5000	10000	2500	5000	10000	2500	5000	10000		
		1,0	D	D	D	90	90	90				D		85		D	D		90	90							
1,5	D	D	D	90	90	90				D		85		D	D		90	90									
2,0	D	D	D	90	90	90				D		85		D	D		90	90									
3,0		D	D		90	90									D												
5,0				D																							
8,0																											
12,0																											
20,0																											
1,0	D	D	D	90	90	90				D		85		D	D		90	90									
1,5	D	D	D	90	90	90				D		85		D	D		90	90									
2,0	D	D	D	90	90	90				D		85		D	D		90	90									
3,0		D	D		90	90									D												
5,0				D																							
8,0																											
12,0																											
20,0																											
1,0	D	D	D	90	90	90				D		85		D	D		90	90									
1,5	D	D	D	90	90	90				D		85		D	D		90	90									
2,0	D	D	D	90	90	90				D		85		D	D		90	90									
3,0		D	D		90	90									D												
5,0				D																							
8,0																											
12,0																											
20,0																											
1,0			D			90									D												
1,5			D			90									D												
2,0			D			90									D												
3,0				D			90									D											
5,0																											
8,0																											
12,0																											
20,0																											
1,0																											
1,5																											
2,0																											
3,0																											
5,0																											
8,0																											
12,0																											
20,0																											
1,0																											
1,5																											
2,0																											
3,0																											
5,0																											
8,0																											
12,0																											
20,0																											

Group 1

Group 2

Group 3

Group 4

Group 5

Group 6

**Table B-17 Installation Type 2, DN ≥ 300. 1.0 bar Vacuum - ground water level to ground level**  
Minimum Backfill Compaction, % Standard Proctor Density. (D = uncompacted (dumped), C = Compacted)

## Appendix C

### Classification and Properties of Native Soils

For the analysis of pipe installation requirements, the native soils are here classified in six groups and related to stiffness through blow counts as defined by a standard penetration test using a split barrel sampler, ASTM D1586. These native soils, which form the trench walls, range from very stable, dense granular soils and very hard cohesive soils to relatively weak, fine grained soils. These same native soils may be considered for use as backfill.

- 1 Blows/foot from standard penetration test, ASTM D1586.
- 2 For higher blow counts,  $M_{sn}$  values increase to 345 MPa for rock.
- 3 When a geotextile pipe zone wrap is used,  $M_{sn}$  values for poor soils can be greater than those listed above.
- 4 When permanent solid sheeting designed to last the life of the pipeline is used in the pipe zone, the constrained soil modulus shall be based solely on the backfill modulus.

#### Correlation to other test methods

There are several different cone penetrometer tests in use around the world. With the potential for significant variations in these different tests, an approximate correlation to standard penetrometer blow counts, N, based on ASTM D1586 can be provided. With the output of the cone penetrometer test,  $q_u$ , expressed in  $kg/cm^2$  the corresponding standard penetrometer blow count, N is:

$$N = q_u/4 \text{ for mechanical cone penetrometer}$$

$$N = q_u/3 \text{ for electrical cone penetrometer}$$

Representation of the native soil is given in **Table C-1**, which follows the general recommendations provided in AWWA M45. The blow count to be used is the lowest value found over an extended period of time in the pipe zone. Normally, the weakest condition of the soil exists when the soil has been subjected to wet conditions for an extended period.

For simplifying reasons, the tables in Appendix B have been calculated with compacted granular / very stiff cohesive soil.

Soil class	Granular		Cohesive		Modulus $M_{sn}$ MPa
	Blow count <sup>1</sup>	Description	$q_u$ kPa	Description	
-	> 50	Very dense	> 600	Very hard	138.0
-	30 – 50	Dense	400 – 600	Hard	69.0
1	15 – 30	Compact	200 – 400	Very stiff	34.5
2	8 – 15	Slightly compact	100 – 200	Stiff	20.7
3	4 – 8	Loose	50 – 100	Medium	10.3
4	2 – 4		25 – 50	Soft	4.8
5	1 – 2	Very loose	13 – 25	Very soft	1.4
6	0 – 1	Very	0 – 13	Very very soft	0.34

<sup>1</sup> Standard penetration test per ASTM D1586

**Table C-1 Native soil classes. Values of Constrained Modulus,  $M_{sn}$**

## Appendix D

### Classification and Properties of Backfill Soils

To be used as backfill for pipes, the soil must provide stiffness to the pipe/soil system and maintain the required stiffness with time. The variety of potential soils that can be used as pipe zone backfill is limitless. Pipe zone backfill may be selected from the soil removed from the trench or may require special soils to be imported to the job site, if the trenched soils are not adequate to serve as backfill. The practical selection of a pipe zone backfill soil depends on ease of compaction to achieve the needed stiffness and availability. Soils suitable to be used as backfill materials are here classified in 4 stiffness categories. Class 5, mentioned in AWWA M45, is not suitable for use as backfill material and therefore not listed here.

#### Soil Class 1, SC I

SC I materials provide maximum pipe support for a given compaction due to low content of sand and fines. With minimum effort these materials can be installed at relatively high stiffness over a wide range of moisture contents. In addition, the high permeability of SC I materials may aid in the control of water and are often desirable for embedment in rock cuts where water is frequently encountered.

However, when groundwater flow is anticipated, consideration should be given to the potential of migration of fines from adjacent materials into the open graded SC I material, see [section A.8](#) .

#### Soil Class 2, SC II

SC II materials, when compacted, provide a relatively high level of pipe support. However, open graded groups may allow migration and should be checked for compatibility with adjacent materials, see [section A.8](#) .

#### Soil Class 3, SC III

SC III materials provide less support for a given density than SC I or SC II materials. Higher levels of compaction effort are required and moisture content must be near optimum to achieve the required density. These materials provide a reasonable level of pipe support once proper density has been achieved.

#### Soil Class 4, SC IV

SC IV materials require geotechnical evaluation prior to use. The moisture content must be near optimum to achieve the required density. When properly placed and compacted, SC IV materials can provide a reasonable level of pipe support. These materials are, however, not suitable for deep burial depths and traffic loads or for compaction with high energy vibratory compactors and tampers. SC IV materials should not be used where water conditions in the trench prevent proper placement and compaction.

General guidelines for classifying backfill soils in stiffness categories are given in [Table D-1](#). For any given backfill soil class the higher the compaction the higher the soil modulus and the higher the support. In addition, the soil modulus also increases with the vertical soil stress level i.e. with burial depth. [Table D-2](#) to [Table D-5](#) give the  $M_{sb}$  values for backfill stiffness categories SC I, SC II, SC III and SC IV as a function of the % Standard Proctor Density (SPD) and vertical stress level. The values apply for pipes installed above the groundwater level. For pipes installed below groundwater level, the constrained soil modulus will be reduced for lower stiffness class soils and lower compaction, see values in parentheses. The vertical stress level is the vertical effective soil stress at the pipe springline elevation. It is normally computed as the design soil unit weight times the depth of fill. Buoyant unit weight should be used below the groundwater level.

Backfill Soil soil class	Description of Backfill Soils
SC I	Crushed rock with < 15% sand, maximum 25% passing the 9.5 mm sieve and maximum 5% fines <sup>2</sup> .
SC II	Clean, coarse-grained soils: SW, SP <sup>1</sup> , GW, GP or any soil beginning with one of these symbols with 12% or less fines <sup>2</sup> .
SC III	Clean, coarse-grained soils with fines: GM, GC, SM, SC or any soil beginning with one of these symbols with 12% or more fines <sup>2</sup> . Sandy or gravely fine-grained soils: CL, ML, (or CL-ML, CL/ML, ML/CL) with 30% or more retained on a no. 200 sieve.
SC IV	Fine grained soils: CL, ML, (or CL-ML, CL/ML, ML/CL) with 30% or less retained on a no. 200 sieve.

Note: Symbols in the table are according to the Unified Soil Classification Designation, ASTM D2487

<sup>1</sup>) Uniform fine sand, SP, with more than 50% passing no. 100 sieve (0.15 mm) is very sensitive to moisture and is not recommended as backfill.

<sup>2</sup>) % fines is the weight percentage of soil particles that pass no. 200 sieve with 0.076 mm opening.

**Table D-1 Backfill soil class classification**

Burial Depth (Soil Density 18.8 kN/m <sup>3</sup> ) m	Vertical Stress Level kPa	Compaction, % maximum Standard Proctor Density	
		Compacted MPa	Uncompacted (dumped) MPa
0.4	6.9	16.2	13.8
1.8	34.5	23.8	17.9
3.7	69.0	29.0	20.7
7.3	138.0	37.9	23.8
14.6	276.0	51.7	29.3
22.0	414.0	64.1	34.5

**Table D-2  $M_{sb}$  for SC I Backfill soil**

Burial Depth (Soil Density 18.8 kN/m <sup>3</sup> ) m	Vertical Stress Level kPa	Compaction, % maximum Standard Proctor Density			
		100 MPa	95 MPa	90 MPa	85 MPa
0.4	6.9	16.2	13.8	8.8 (7.5)	3.2 (2.2)
1.8	34.5	23.8	17.9	10.3 (8.8)	3.6 (2.5)
3.7	69.0	29.0	20.7	11.2 (9.5)	3.9 (2.7)
7.3	138.0	37.9	23.8	12.4 (10.5)	4.5 (3.2)
14.6	276.0	51.7	29.3	14.5 (12.3)	5.7 (4.0)
22.0	414.0	64.1	34.5	17.2 (14.6)	6.9 (4.8)

**Table D-3  $M_{sb}$  for SC II Backfill soil (reduced values below ground water table in parentheses)**

Burial Depth (Soil Density 18.8 kN/m <sup>3</sup> ) m	Vertical Stress Level kPa	Compaction, % maximum Standard Proctor Density			
		100 MPa	95 MPa	90 MPa	85 MPa
0.4	6.9	-	9.8 (4.9)	4.6 (2.3)	2.5 (1.3)
1.8	34.5	-	11.5 (5.8)	5.1 (2.6)	2.7 (1.4)
3.7	69.0	-	12.2 (6.1)	5.2 (2.6)	2.8 (1.4)
7.3	138.0	-	13.0 (6.5)	5.4 (2.7)	3.0 (1.5)
14.6	276.0	-	14.4 (7.2)	6.2 (3.1)	3.5 (1.8)
22.0	414.0	-	15.9 (8.0)	7.1 (3.6)	4.1 (2.1)

**Table D-4  $M_{sb}$  for SC III Backfill soil (values below ground water level in parentheses)**

Burial Depth (Soil Density 18.8 kN/m <sup>3</sup> ) m	Vertical Stress Level kPa	Compaction, % maximum Standard Proctor Density			
		100 MPa	95 MPa	90 MPa	85 MPa
0.4	6.9	-	3.7 (1.11)	1.8 (0.54)	0.9 (0.27)
1.8	34.5	-	4.3 (1.29)	2.2 (0.66)	1.2 (0.36)
3.7	69.0	-	4.8 (1.44)	2.5 (0.75)	1.4 (0.42)
7.3	138.0	-	5.1 (1.53)	2.7 (0.81)	1.6 (0.48)
14.6	276.0	-	5.6 (1.68)	3.2 (0.96)	2.0 (0.60)
22.0	414.0	-	6.2 (1.86)	3.6 (1.08)	2.4 (0.72)

**Table D-5  $M_{sb}$  for SC IV Backfill soil (values below ground water level in parentheses)**

**!** **Note:**  $M_{sb}$  values at intermediate vertical stress levels not given in **Table D-2** to **Table D-5** can be obtained by interpolation. The % maximum standard Proctor density indicates the dry density of the compacted soil as a percentage of maximum dry density determined in accordance with ASTM D698.

The German static calculation method for buried pipes ATV 127 is frequently used. As an aid, the following is the correlation.

Between the backfill soil stiffness categories of these instructions and the ATV 127 soil groups, G1 to G4:  
SC I corresponds to the best of the G1 soils. SC II corresponds to the G1 soils and the best of the G2 soils.

SC III corresponds to the weaker G2 soils and the best of the G3 soils. SC IV corresponds to the weaker G3 soils and the best of the G4 soils.

## Appendix E

### Field Testing to assist Classification of Native Soils

Native Soil Characteristic	Measurable Group
1	Can be barely penetrated with thumb
2	Can be penetrated with thumb to 4 mm
3	Can be penetrated with thumb to 10 mm
4	Can be penetrated with thumb to 25 mm
5	Can be penetrated with thumb to 50 mm
6	Can be penetrated by fist to 25 mm

**Table E-1 Simple field test estimation soil group<sup>1)</sup>**

<sup>1)</sup> Based on Peck, Hanson and Thornburn, "Foundation engineering", 2nd Ed., John Wiley and Sons, Inc., 1974 and ASTM D2488.

## Appendix F

### Compaction of Backfill

This appendix provides helpful tips for compacting the various types of backfill. The maximum and minimum allowable installation depths will be affected by the selection and compaction of pipe zone backfill. The stiffer the soil, the deeper a given pipe can be installed to achieve a limited deflection or vacuum. This guide offers a general background for soil behaviour to provide a better understanding of our installation criteria. Include considerations for seasonal variations when assessing the potential for moisture content of both in situ and backfill soils. The compaction value recommended to provide a soil modulus value is to be considered as a minimum value and field densities should be at or higher than the requirement.

As a means of "calibrating" an installation method with a given backfill type, we recommend that specific attention be given to compaction techniques and relative compaction result during the installation of the initial sections of pipe used at a given installation site. By correlating the resulting compaction as a function of the soil class, method of placement of soil in the haunch zones and side fill areas, compaction methods for haunch and side fill areas, lift heights used, moisture content and number of passes, a good "feel" for the efforts needed for installation can be determined. When these initial pipes are installed, testing should be conducted frequently to assure compaction and pipe deflection criteria are being achieved.

With this correlation, a technique for compacting a given soil class can be "calibrated" and the frequency for testing can be reduced. With this correlation, the workers gain a good understanding of the requirements for proper installation when using a specific backfill type for a specific set of requirements (ASTM D5080 offers a reasonable method for rapidly measuring field density and moisture content of soils). There are many methods available for measuring field density of the compacted backfill.

A measurement of the increase in the vertical diameter of the pipe is a reasonable measure of compaction effort used during the installation and another good "calibration" measurement. If backfill has been properly placed and compacted in the haunch areas of the pipe, a good method for judging compaction is the vertical diameter measurement when the backfill placement has reached the top of the pipe (or at any stage if consistently monitored). However, be aware that when using high levels of compaction effort, excessive vertical increase in diameter may result. If this condition occurs, contact the pipe supplier for assistance, and do not continue with the installation using the method that creates the excessive increase in vertical diameter.

Pipe zone backfill materials should be placed and compacted in uniform lifts on both sides of the pipe. For backfill placement and compaction in the haunch areas, start compacting under the pipe and work away from the pipe. For side fill, compaction usually progresses best when the backfill is compacted at the trench wall first and compaction progresses toward the pipe. Usually the number of "passes" or repeated applications of the compaction equipment (at a constant rate of movement) will increase the compaction. A good way to determine a sufficient compaction method is to measure the compaction and other response measurements as a function of the number of passes of a given compaction device. Use the number of passes and other criteria such as moisture content and vertical deflection as a means of controlling the installation procedure. If the compaction equipment is changed, the number of passes to achieve the specified compaction may be affected. Heavier and wider plate vibrators typically compact deeper and to a higher degree than lighter and narrower ones. Likewise, the smaller and lighter impact compactors have a less effective depth than the larger, heavier ones.

Compaction over the top of the pipe must only proceed if there is sufficient material not to impact the pipe. At least 150 mm cover should be sufficient when using a hand operated plate vibrator compactor; however, 300 mm is recommended when using a hand operated impact compactor. A compaction of no more than 85% SPD can realistically be achieved when compacting the first 300 mm lift directly over the pipe crown (top). For more details see [section 3.6](#) →. Backfill soils that are granular in character provide relatively high stiffness with minimal compaction effort.

01
02
03
04
05
06
07
08
09
10
app.

Compact granular soils have little tendency to creep or consolidate with time. Granular soils are less sensitive to moisture, both at the time of placement and during long-term use. When finer grained soils are used as backfill, the support for the pipe is typically reduced. Granular soil with more than 12% by weight of fines (soils with particle size less than 75 microns) are significantly affected by the characteristic of the finer materials. If the fines are mostly silts (37 to 75 microns), the typical soils are moisture sensitive, have a tendency to be transported by flowing water and require some additional effort to compact. If the fines are mostly clay (less than 37 microns and cohesive), the soils are more moisture sensitive, which reduces stiffness, and the soil will creep with time. Typically, more compaction effort is needed to achieve the required density. By limiting soils to a liquid limit of 40%, the highly moisture sensitive and plastic soils will be eliminated from use.

Backfill classes SC I and SC II are relatively easy to use and very reliable as backfill materials for pipes. These soils have low moisture sensitivity. Backfill can be easily compacted using a plate vibrator compactor in 200 to 300 mm lifts. Occasionally, a filter fabric should be used in combination with gravel soils to preclude fines migration and subsequent loss of pipe support. See **section A.8** → for the criteria.

Backfill class SC III soils are acceptable and often readily available as backfill materials for pipe installations. Many local soils, in which the pipe is installed, are class SC III and therefore the trenched soil can be directly reused as pipe-zone backfill. Care is to be taken with these soils as they can be moisture sensitive. The characteristics of class SC III soil are often dictated by the characteristics of the fines. Moisture control may be required when compacting the soil to achieve the desired density with reasonable compaction energy and easily used compaction equipment. Compaction can be achieved by using an impact compactor in 100 to 200 mm lifts.

Backfill class SC IV can only be used as pipe-zone backfill with the following precautions:

- Moisture content must be controlled during placement and compaction.
- Do not use in installations with unstable foundations or with standing water in the trench.
- Compaction techniques may require considerable energy, and practical limitations of relative compaction and resulting soil stiffness must be considered.
- When compacting, use lifts of 100 and 150 mm with an impact compactor such as Whacker or pneumatic rammer (pogo stick).
- Compaction tests should be conducted periodically to assure that proper compaction is achieved. See **Appendix F** → for further information.

The compaction of finer grain backfill is easily accomplished when the material is at or near its optimum moisture content.

When backfilling reaches pipe springline, all compaction should start near the trench sides and proceed towards the pipe.

It is recommended that placing and compacting of the pipe zone backfill is done in such a way as to cause the pipe to ovalise slightly in the vertical direction. Initial vertical ovalisation, however, must not exceed 1.5% of pipe diameter as measured when backfill reaches pipe crown. The amount of initial ovalisation obtained will be related to the energy required to achieve the relative compaction needed. The high energy levels that may be necessary with backfill classes SC III and SC IV may lead to exceeding the limit. If this occurs consider a higher stiffness pipe or other backfill materials or both.

## Appendix G

### Approximate Weights for Pipes and Couplings

The data in the following table is intended for the planning and execution of pipe installations. They are nominal data based on the Flowtite Pressure Pipe (FP 2.1) design.

dn	PN1				PN6				PN10			
	SN2500	SN5000	SN10000	Coupling	SN2500	SN5000	SN10000	Coupling	SN2500	SN5000	SN10000	Coupling
	kg/m	kg/m	kg/m		kg/m	kg/m	kg/m		kg/m	kg/m	kg/m	
300	9,4	11,8	15	6,9	8,1	10,4	12,6	11	7,9	10,2	12,6	11,2
350	12,7	16,1	20,5	8	11	14,2	17,2	12,5	10,5	13,7	17,2	12,9
400	16,4	20,9	26,7	9	14,4	18,5	22,3	14,1	13,4	17,5	22,3	14,6
450	20,7	26,4	32,9	10	18,3	23,5	28,2	15,7	16,7	21,8	28,2	16,4
500	25,7	32,9	40,9	11	22,8	29,1	34,8	17,3	20,5	26,7	34,8	18
600	35	43,5	53,3	13,1	31,4	39,3	47,9	28,8	27,5	36	47,9	29,8
700	47,8	58	72	15,9	42,3	53,2	65,6	33	37,1	48,8	65,6	34,8
800	60,5	74,3	94,5	18,7	55	68,8	85,4	37,3	48,3	63,1	85,4	40,9
900	76,9	93,9	117,8	21,5	69,4	86,7	107,3	42,8	60,8	80,6	107,3	47,1
1000	92,4	117,7	144,7	24,2	85,5	106,3	132,7	48,4	74,7	99,1	132,7	53,5
1100	111,4	139,9	174,4	26,9	103,4	128,4	160,7	53,9	89,9	119,4	160,7	60
1200	135,1	167,8	205,6	48,6	122,2	151,9	190,4	59,4	106,5	141,9	190,4	66,5
1300	155,8	195	240	53,1	143,5	179,1	223,3	64,9	124,5	166	223,3	73
1400	181	226,1	278,6	57,6	165,7	207,1	258,5	70,5	144,1	191,8	258,5	79,4
1500	209	257,1	317,5	62,2	189	238	295,5	76	164,6	219,9	295,5	86,2
1600	234,6	290,2	359,9	67	215,5	269,8	336,7	81,8	187,4	250,2	336,7	93,1
1700	266,4	328,9	407,9	71,7	244,9	304,7	378,9	87,6	211,1	281,8	378,9	100,1
1800	295,2	366,2	453,2	76,3	274	341,3	424,8	93,3	236,2	315,5	424,8	107
1900	328,5	407,6	502,6	81,1	304,1	379,3	473	99,2	262,3	351,2	473	115,9
2000	360,4	448,9	554,6	86	336,8	419,3	522,5	105,2	290,7	388,8	522,5	125,3
2100	399,3	495,9	610,1	91	370,9	462,2	576,1	111,2	320	427,9	576,1	134,7
2200	434,4	541,3	670,9	96	406,5	507	632	117,4	350,7	469,4	632	143,8
2300	473,5	591,9	731,8	101	443,9	552,9	689,6	123,4	383,3	513,4	689,6	153,2
2400	514,1	641,4	797,8	106,1	482,9	601,6	749,8	129,7	416,3	558,2	749,8	162,5
2500	559,1	691,8	0	111,4	522,4	653,5	814,5	136,1	451,7	605,4	814,5	171,8
2600	604,9	748,5	0	167,4	565,8	706	880,8	200,9	488	653,8	880,8	232,2
2700	647,8	804,1	0	175,3	609,8	759,9	949,1	210,4	525,7	704,8	949,1	243,3
2800	697,3	866,9	0	183,6	654,1	817,8	1020,6	220,3	565,2	758,1	1020,6	254
2900	743,3	926,6	0	191,8	701,6	877,4	1092,5	230,1	605,7	812,5	1092,5	264,8
3000	799	995,3	0	199,7	751,6	937,4	1170,1	239,7	648,1	869	1169,5	275,4
3100					799,9	1000,1	1247,8	261,5	690,6	928,5	1247,8	300,8
3200					852,8	1065,2	1330	272,1	735,8	988,5	1330	312,6
3300					907,4	1133	1414,7	282	782,5	1051,3	1414,7	324,2
3400					961,9	1203	1499,3	292,8	830,6	1114,4	1499,3	335,8
3500					1019,5	1272,8	0	303	879,1	1182	0	347,3
3600					1078,6	1344,9	0	314	930,4	1249,5	0	359,3
3700					1138,9	1422,9	0	324,4	982	1319,9	0	370,9
3800					1198,7	1500,2	0	334,9	1035,7	1392	0	382,6
3900					1263,7	0	0	345,5	1090,7	1465,6	0	394,4
4000					1330	0	0	355,9	1146	1540,8	0	406,3



- 01
- 02
- 03
- 04
- 05
- 06
- 07
- 08
- 09
- 10

app.

PN16				PN20				PN25				PN32			
SN2500	SN5000	SN10000	Coupling	SN2500	SN5000	SN10000	Coupling	SN2500	SN5000	SN10000	Coupling	SN2500	SN5000	SN10000	Coupling
kg/m	kg/m	kg/m		kg/m	kg/m	kg/m		kg/m	kg/m	kg/m		kg/m	kg/m	kg/m	
7,5	9,4	12,1	11,6	7,3	9,2	11,7	11,8	0	9,1	11,4	11,8			11,2	13,9
9,9	12,6	16,2	13,4	9,8	12,2	15,6	13,5		12,1	15,3	13,7			14,9	16,1
12,6	16	20,8	15,7	12,5	15,8	20,1	15,3		15,4	19,5	15,7			19	18,4
15,8	19,9	25,3	17,2	15,5	19,5	25,1	17,2		19,1	24,3	17,7			23,6	20,8
19,2	24,6	31,7	18,9	18,8	23,8	30,6	19,5		23,3	29,6	20,1			28,8	22,9
25,7	32,9	43,1	31,2	25,2	31,9	41,1	32,7		31,1	39,7	34,6			38,5	39,3
34,5	44,4	58,1	38,1	33,7	42,9	55,5	38,3		41,8	53,5	40,4			51,9	47,8
44,5	57,4	75,2	45,3	43,5	55,5	71,8	45,5		54,1	69,3	48,9			67,2	62,3
55,8	72,1	94,9	49,6	54,5	69,7	90,5	51,6		67,8	87,2	57,2			84,4	73,4
68,5	88,6	116,6	56,5	66,8	85,5	111	59,4		83,3	107	72,7			103,6	90,6
82,4	106,6	140,7	63,9	80,3	102,9	133,9	69		100,2	129	87,4			124,8	106,5
97,6	126,3	166,9	71,5	95	121,9	158,7	82,3		118,6	153	101,2			148	121,8
113,9	147,8	195	79,4	111	142,6	185,9	94,8		138,7	178,8	114,8			173	136,7
131,7	171,1	226,1	89,4	128,2	164,8	215,3	107,1		160,4	206,9	128,1			200,2	151
150,6	195,7	259,2	101	146,6	188,7	246,6	119,1		183,6	237	141,2			229,2	165,1
170,9	222,2	294,3	112,4	166,3	214,2	280	131,2		208,4	269,1	154,1			260,2	178,9
192,4	250,6	331,6	123,6	187,3	241,2	315,5	142,8		234,6	303,4	167			292,7	192,4
215,3	280,2	371,6	134,4	209,5	269,9	353,3	154,6		262,4	339,5	179,4			327,4	205,9
239,3	311,6	413,1	145,5	232,9	300,3	393,1	166,1		292,7	377,6	191,4			0	0
264,6	345,1	457,4	156,3	257,5	332,1	434,8	178		322,9	418,9	203,3			0	0
291,4	379,8	503,7	167	283,4	365,6	479	189,4		355,6	460,5	215,1			0	0
319,2	416,4	552,4	177,8	310,6	400,8	525	201,2		389	504,6	226,8			0	0
348,3	454,5	603,7	188,3	338,8	437,6	573,4	212,6		424	550,5	238,7			0	0
378,9	494,6	656,7	199,2	367,9	475,8	623,7	224,1		463,1	599	250,3			0	0
410,5	536	712,4	209,9	398,8	515,3	677,6	234,7		0	0	0			0	0
443,7	579,6	769,3	267,9	430,2	557,4	730,9	305,5		0	0	0			0	0
477,6	624,6	829,9	279,9	464	599,9	787,5	323,8		0	0	0			0	0
513,5	671,2	891,5	292,5	498,3	645,6	846,9	342,9		0	0	0			0	0
549,1	719,1	956,9	304,1	533,6	690,6	907,4	362,2		0	0	0			0	0
587,8	769,5	1023	315,2	571,1	740,1	971,8	382,4		0	0	0			0	0
626,9	820	1090,9	352,8	0	0	0	0		0	0	0			0	0
666,5	873,5	1162,6	370,9	0	0	0	0		0	0	0			0	0
710,3	928,6	1236,3	389,2	0	0	0	0		0	0	0			0	0
751,8	984,7	1311,5	412,5	0	0	0	0		0	0	0			0	0
0	0	0	0	0	0	0	0		0	0	0			0	0
0	0	0	0	0	0	0	0		0	0	0			0	0
0	0	0	0	0	0	0	0		0	0	0			0	0
0	0	0	0	0	0	0	0		0	0	0			0	0
0	0	0	0	0	0	0	0		0	0	0			0	0
0	0	0	0	0	0	0	0		0	0	0			0	0
0	0	0	0	0	0	0	0		0	0	0			0	0

## Appendix H

### Joint Lubricant Requirements

DN mm	Lubricant kg
100-350	0,1
400-600	0,2
700-900	0,3
1000-1200	0,4
1300-1500	0,5
1600-1800	0,6
1900-2100	0,7
2200-2400	0,8
2500-2700	0,9
2800-3000	1,0
3100-3300	1,1
3400-3500	1,2
3600-4000	1,3

**!** **Note:** The table shows approximate amount of lubricant for each gasket-spigot

## Appendix I

### Definitions and Terminology

Term	Description
Nominal diameter, DN	The diameter classification of pipe, expressed in mm.
Nominal Pressure, PN	The pressure rating of a pipe, expressed in bars or pressure.
Nominal Stiffness, SN	The minimum initial specific stiffness, $EI/D^3$ , of a pipe as measured by a load required to deflect a pipe ring, expressed in $N/m^2$ .
Pipe crown	The top inside surface of the pipe.
Pipe invert	The bottom inside surface of a pipe.
Depth of bury	The depth of cover over the top of a pipe.
Deflection	The change in vertical diameter typically expressed as a percentage of the nominal pipe diameter.
Springline	The mid height of the pipe, the 90 and 270 degree locations of a pipe as measured from the top centre of the pipe.
Constrained soil modulus, $M_s$	A secant modulus of soil measured by a one dimensional compression test used to describe soil stiffness.
Standard Proctor Density, SPD	The maximum dry density obtained at optimum moisture content when tested by ASTM D698, used to define 100% standard Proctor density.
Percent Standard Proctor Density	The achieved dry density/maximum dry density expressed in %.
Blow Counts	The number of impacts of a 140 pound (64 kg) hammer dropping 30 inches (76 cm) to drive a split barrel sampler 12 inches (30 cm) by ASTM D1586.

This Installation Guide for Buried Pipe is the intellectual property of Flowtite Technology. All rights reserved.

No part of this Installation Guide may be reproduced, stored in a retrieval system, or transmitted in any form or by any means, electronic, mechanical, photocopying, recording or otherwise without the prior permission of the intellectual property owner.

## Hatching Codes

Bedding / Foundation  
compacted

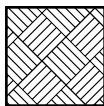

Bedding / Foundation

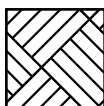

Backfill

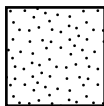

Backfill compacted

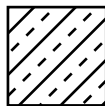
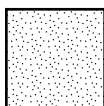

Concrete



Wood

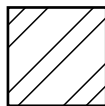

Stone

The Flowtite technology is owned and licensed worldwide by Amiblu.  
Find more information and contact details at [www.amiblu.com](http://www.amiblu.com).

# Amiblu<sup>®</sup>

**Amiblu Technology AS**

Østre Kullerød 3  
3241 Sandefjord  
Norway  
T: + 47 971 00 300  
[info.technology@amiblu.com](mailto:info.technology@amiblu.com)  
[www.amiblu.com](http://www.amiblu.com)

**DISCLAIMER** This handbook is intended as a guide only. All values listed in the product specifications are nominal. Unsatisfactory product results may occur due to environmental fluctuations, variations in operating procedures or interpolation of data. We highly recommend that any personnel using this data have specialised training and experience in the application of these products and their normal installation and operating conditions. The engineering staff should always be consulted before any of these products are installed to ensure the suitability of the products for their intended purpose and applications. We hereby state that we do not accept any liability, and will not be held liable, for any losses or damage which may result from the installation or use of any products listed in this handbook as we have not determined the degree of care required for product installation or service. We reserve the right to revise this data, as necessary, without notice. We welcome comments regarding this handbook.