

Rinnai

Installation guide

Ember

Models: RDV600N/RDV600L
RDV700N/RDV700L

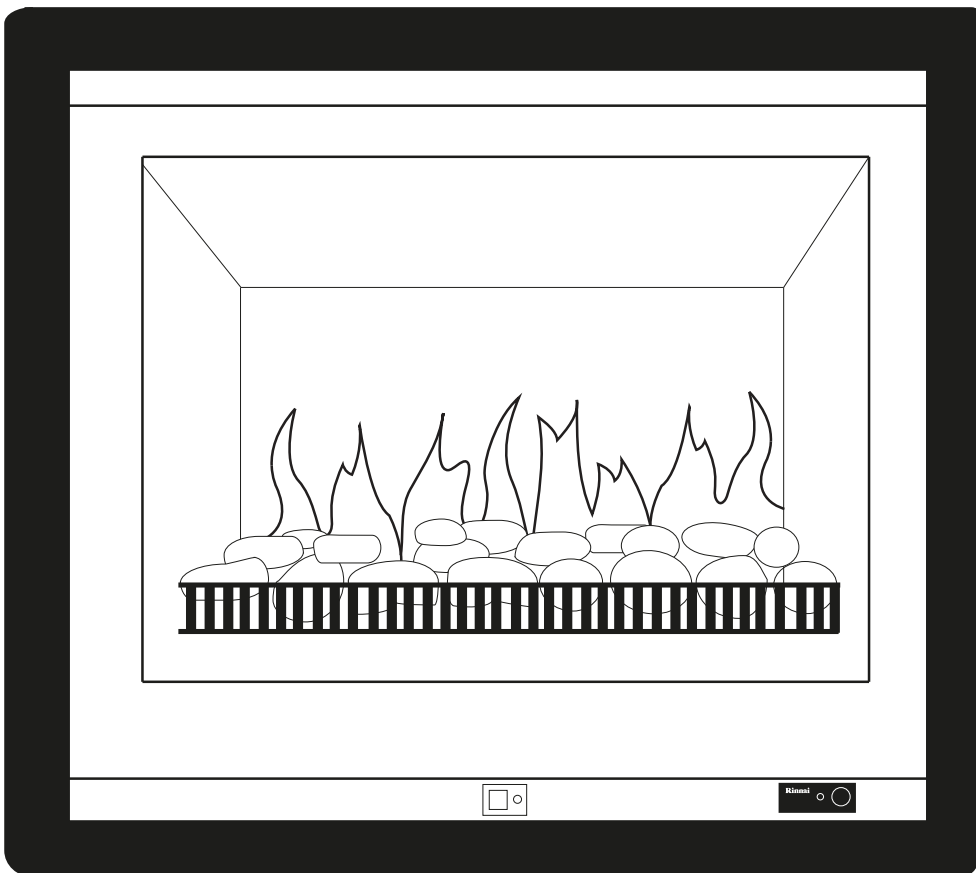

Important:

Appliance must be installed with a Rinnai approved flue system.

This appliance shall be installed in accordance with:

- Manufacturer's installation instructions
- AS/NZS 5601 Gas Installations

Installation, servicing and repair shall be carried out only by authorised personnel.

Warning

Improper installation, adjustment, alteration, service or maintenance can cause property damage, personal injury or loss of life.



For more information about buying, using, and servicing of Rinnai appliances call: 0800 RINNAI (0800 746 624).

Rinnai New Zealand Limited
105 Pavilion Drive, Mangere, Auckland
PO Box 53177, Auckland Airport, Auckland 2150

Phone: (09) 257 3800
Email: info@rinnai.co.nz
Web: www.rinnai.co.nz
www.youtube.com/rinnainz
www.facebook.com/rinnainz

contents:







Before you start.....	4
Ember specification	5
Dimensions.....	6
Gas and electrical supply	8
Enclosure dimensions	9
Clearances from combustibles.....	10
TV installation.....	12
Ember masonry installation overview	14
Ember mock chimney installation overview	16
Installing the zero clearance frame	18
Attaching the flexi flues to the spigot plate	19
Burn media installation.....	20
Adding the glass and vermiculite	21
Log set installation	22
Stone set installation	24
Commissioning	26
Installing the frame	27
Test operation and lighting sequence.....	28
Installation checklist and customer handover	28
Wiring diagram	29
Ember flueing.....	30
Flueing options.....	32
Flue kits and components	37

Before you start

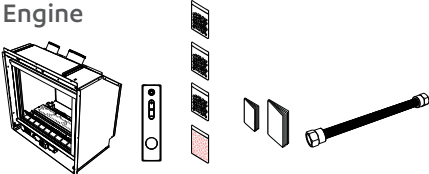
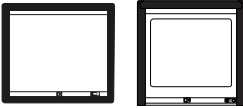
Unpack the appliance and components and check for damage. DO NOT install any damaged items. Check all components have been supplied and that you have the correct gas type.

Read these instructions to get an overview of the steps required before starting the installation. Failure to follow these instructions could cause a malfunction of the appliance. This could result in serious injury and/or property damage.

Ensure the flue termination will meet the required flue clearances as shown in AS/NZS 5601.1 before installation.

Item	Masonry installation		Mock chimney installation	
	Ember 600	Ember 700	Ember 600	Ember 700
Engine 	✓	✓	✓	✓
4-sided or 3-sided frame 	✓	✓	✓	✓
Zero clearance frame  <p>A must-have for mock chimney installations as it gives automatic clearances to combustibles and is critical for keeping the installation square.</p>			✓	✓
Infill panel (if needed) 	✓	✓		
700 Masonry frame  <p>Wider masonry frame for the Ember 700, designed to cover a larger cavity opening.</p>		✓		
Burn media  <p>Option of a log or stone set—ensure you have the correct set before starting, they are different for each model.</p>	✓	✓	✓	✓
Masonry flue components  <p>Flexi flue components for a vertical or horizontal chimney termination</p>	✓	✓		
Mock chimney flue components  <p>Flue components for a vertical or horizontal termination.</p>			✓	✓

Ember specification

Ember 600 specification summary

Input	= 12-23 MJ/h
Output	= 2.5-5.0* kW
Efficiency	= 77% (on high)
Heating area	= up to 85 m ² **
Gas type	= NG or ULPG

Ember 700 specification summary

Input	= 14-27 MJ/h
Output	= 3-6.0* kW
Efficiency	= 77% (on high)
Heating area	= up to 99 m ² **
Gas type	= NG or ULPG

A direct vent inbuilt gas fireplace with a glass front and convection fan, pushing warm air from the top of the appliance. Operated with an infra-red remote control.

Different burn media and frame options available.

* Will vary according to gas type and flue configuration.

** Will vary depending on geographical location in NZ.

Suitability

Suitable for masonry installations and installations into a mock chimney, in open plan areas and living rooms.

Data plate

Located on the lower RHS of the base panel in front of the gas control.

Convection fan

120 V AC 50 Hz 2-speed centrifugal blower.

Lighting

Halogen lamps 240 V 25 W x 2.

Gas connection

Brass ½ " BSPT male fitting, the gas supply terminates inside the heater—lower right hand side of the appliance.

Ignition

230-240 V AC 50 Hz high voltage electronic spark generation unit.

Installation considerations

Room size—smaller rooms will heat up quickly, and due to the efficiency of the appliance, the Ember will turn to a low flame setting once the set temperature has been reached.

For efficient performance Rinnai recommends installing the fire as close to the floor as possible. If the unit is installed higher up the wall the movement of air from the convection fan, depending on the room configuration, could create draughts.

Noise level: 37-45 dB(A)

Flueing: Masonry

Colinear flexi flue, air intake Ø 75 mm, exhaust Ø 100 mm. Appliance must be installed with a Rinnai Ember flue system.

Flueing: Mock chimney

Colinear (air intake Ø 75 mm, exhaust Ø 100 mm) to coaxial direct vent flueing (inner Ø 100 mm, outer Ø 170 mm). Appliance must be installed with a Rinnai Ember flue system.

Electrical

This heater has a 1.5 m power cord with a three pin plug supplied. The power cord passes through a slot in the back left hand corner of the appliance.

- High = 110 W
- Standby = <1W

Safety devices

Flame failure sensing system, pressure relief, overheat safety switch, air temperature sensor, thermal fuse, overcurrent fuse, and spark detector.

Temperature control

Once the unit is turned on the infra-red remote* is used to control the flame height and heat output.

If the remote is not used the Ember will automatically modulate between the burner settings to maintain the default set temperature of 22 °C.

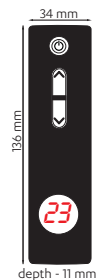

* Temperature sensor is located in the bottom of the remote

Weights

- Ember 600 = 51 kg
- Ember 700 = 55 kg

Dimensions (mm)

Ember 600 with 4-sided frame (mock chimney installations)

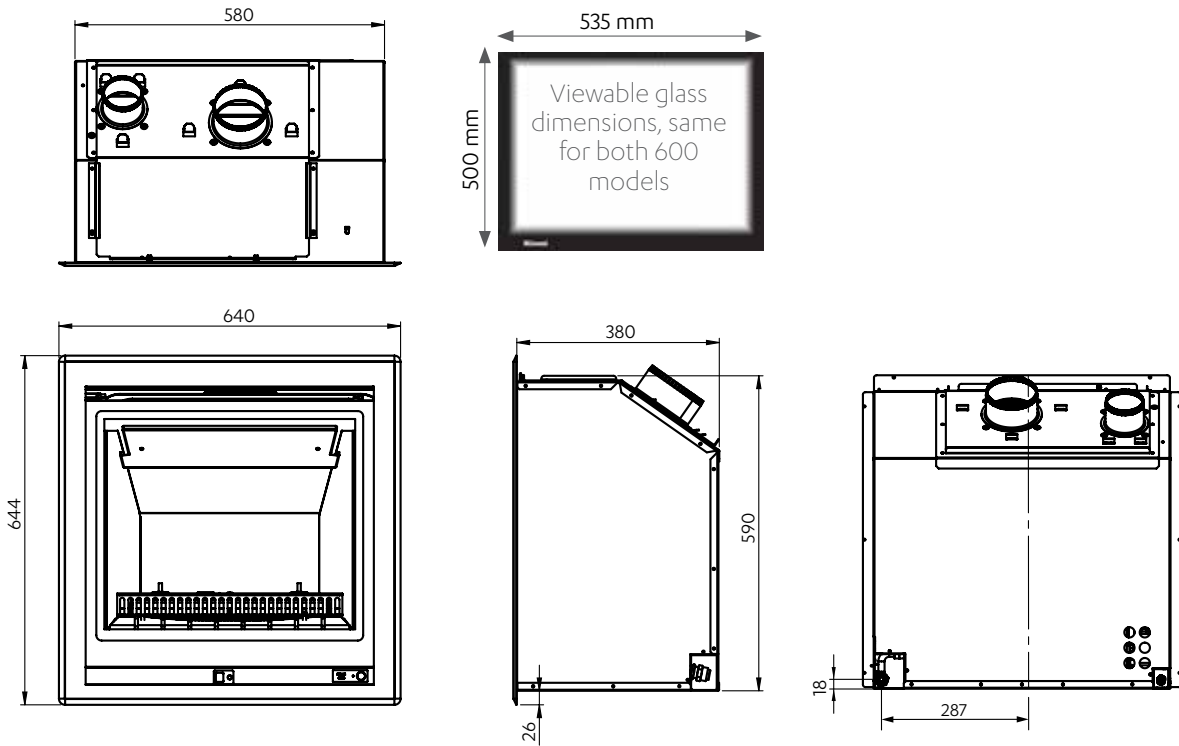

Ember 600 with 3-sided frame (masonry installations or mock chimney installations with a hearth)

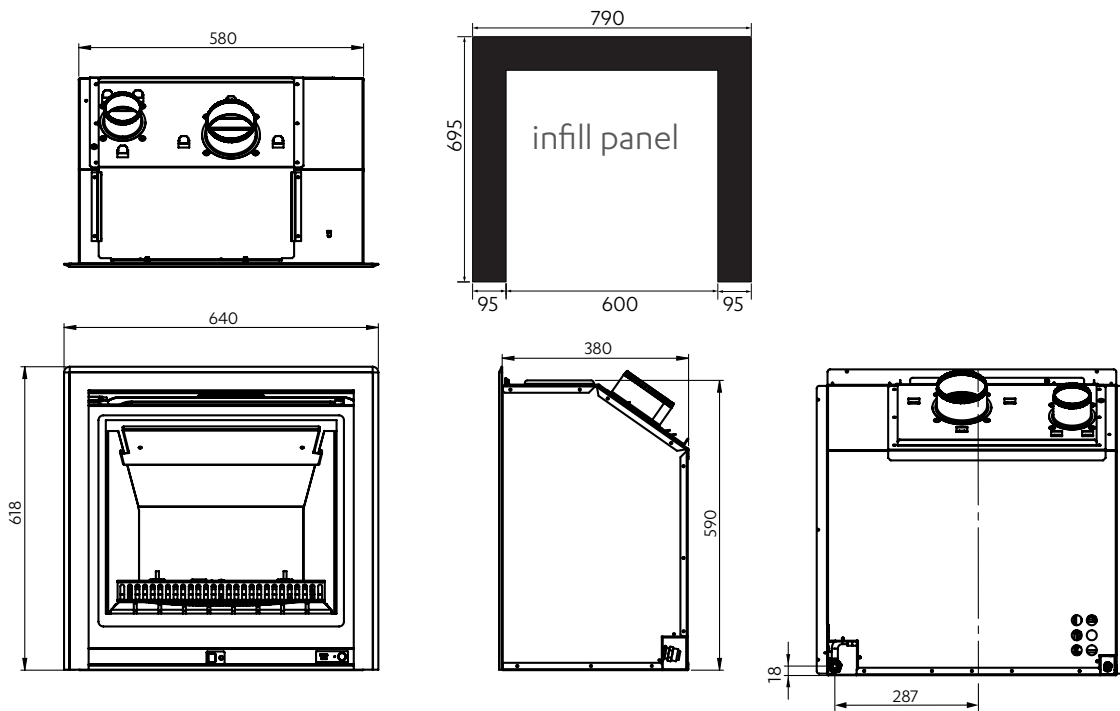

Ember 700 with 4-sided frame (mock chimney installations)

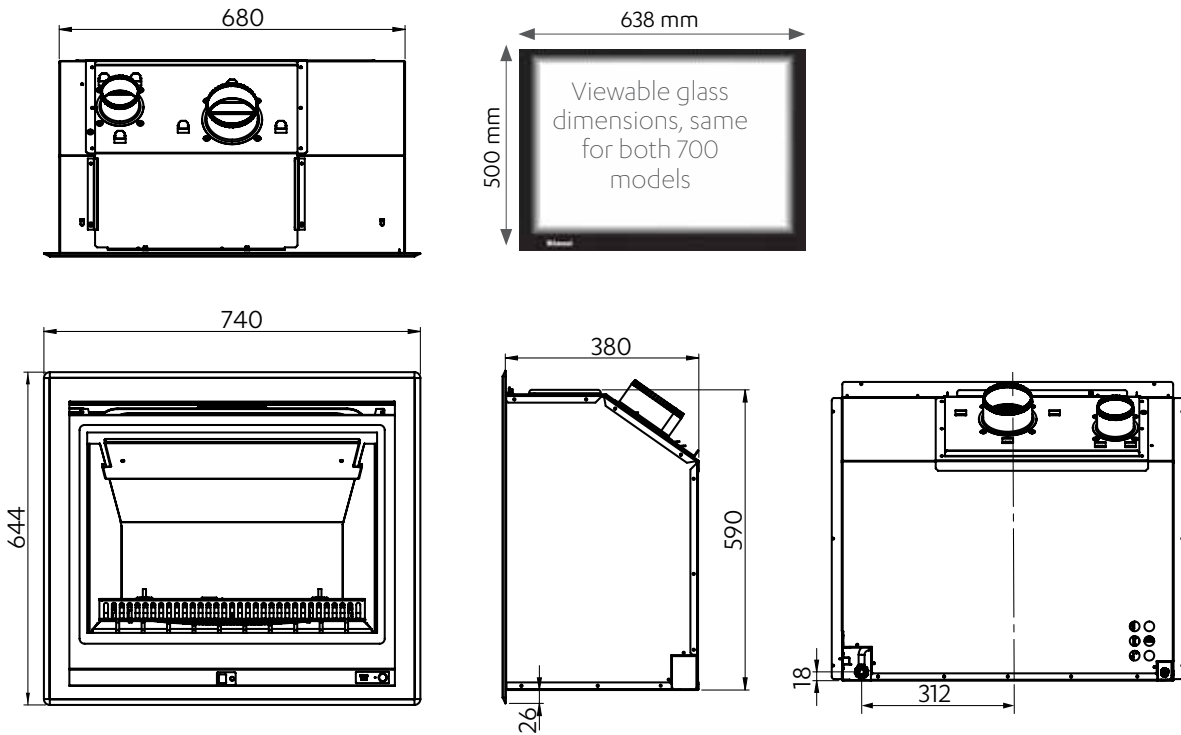

Ember 700 with 3-sided frame (masonry installations or mock chimney installations with a hearth)

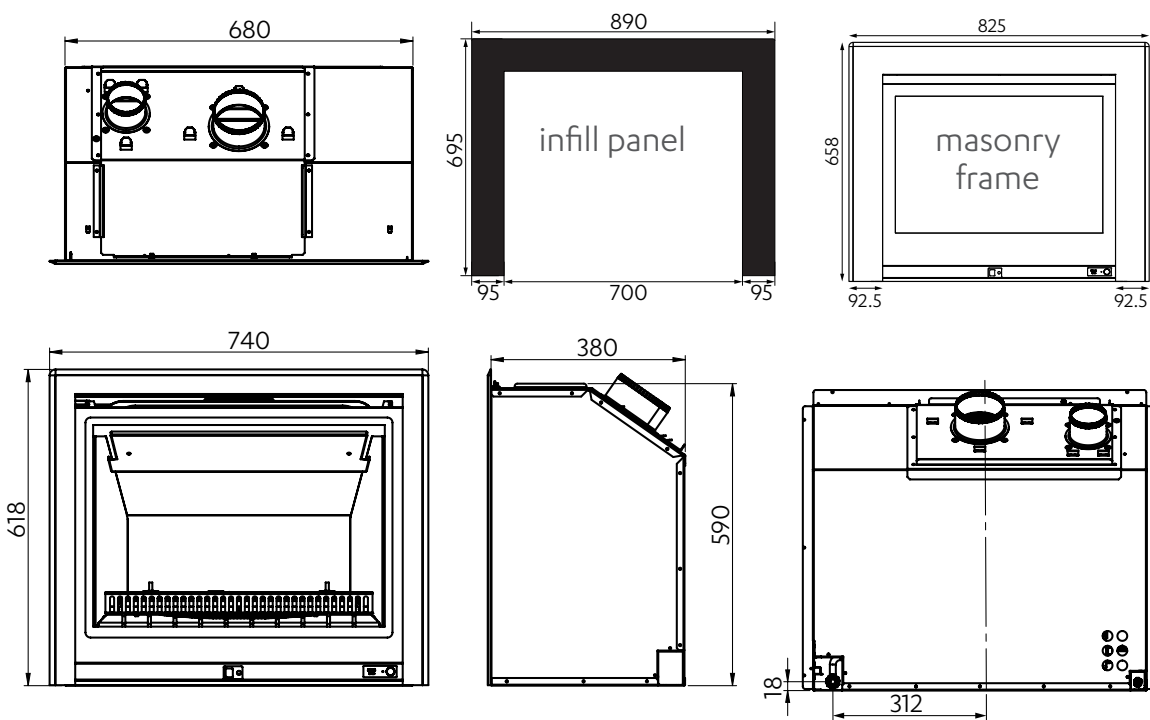

Gas supply

Gas pipe sizing must consider the gas input to this appliance, as well as other gas appliances in the premises. The gas supply termination is inside the heater, and enters from the lower right hand side of the appliance.

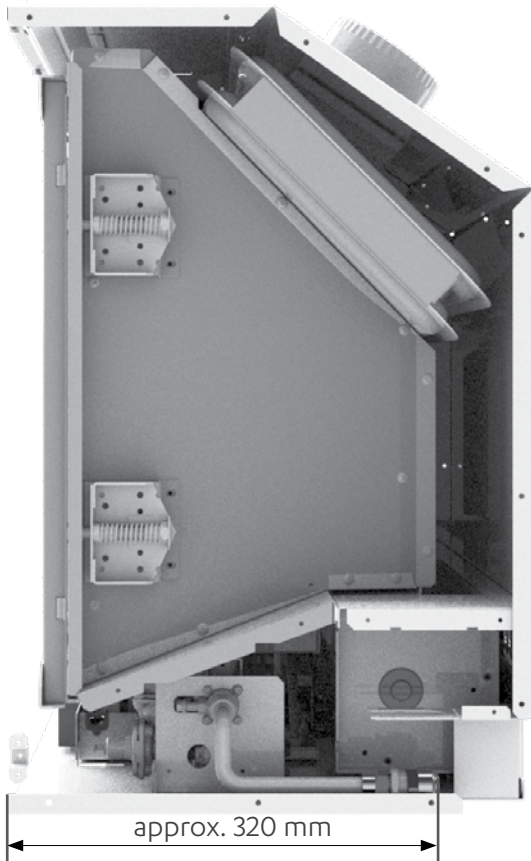

Purging the gas supply

Foreign materials and debris such as swarf, filings etc. must be purged from the gas supply. Failure to do so may cause damage to the control valve causing it to malfunction.

Gas connection

A small spanner has been provided, located in the commissioning pouch on top of the PCB cover, to help with the gas connection as space is quite tight. Please return the spanner to the pouch when finished.

 The use of a rubber hose for any gas connection to a fixed appliance is not authorised by the manufacturer.

Electrical supply

The Ember is fitted with a 1.5 m power cord and 3-pin plug. The power cord passes through a slot in the back left hand corner of the appliance.

The connection is either direct wired* or connected to a power point within the cavity. This must be connected to a dedicated earthed power point. The electric isolation switch must be accessible after the appliance has been installed.

The fire must not be located immediately below a socket outlet (potential fire hazard).

If the supply cord is damaged, it must be replaced by a licensed tradesperson. This must be a genuine replacement part available from Rinnai.

* Consult a qualified electrician if direct wiring is required as it must comply with AS/NZS 5601 and AS/NZS 3000 and other relevant local regulations

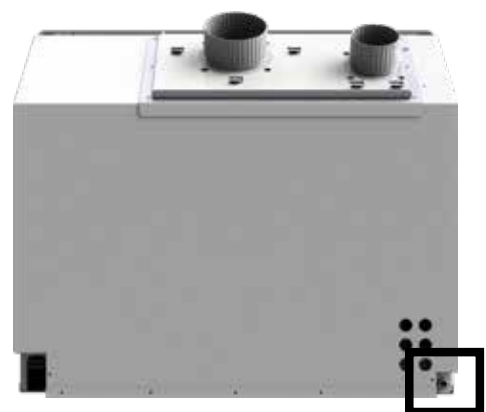

Enclosure dimensions

The Ember must be positioned within the enclosure on a flat level surface that allows free movement of the appliance. The enclosure must be capable of supporting 1.5 times the weight of the Ember.

Masonry

Actual chimney size needs to be at least 200 x 200 mm for the two flexi flues to fit down the chimney.

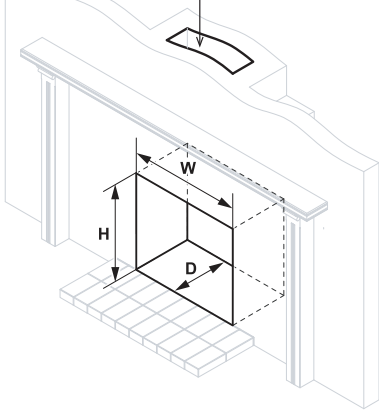

	600	700
W-width	600 mm	700 mm
Infill panel*	600-750 mm	700-850 mm
Masonry frame*	N/A	700-785 mm
H-height	600 mm	600 mm
Infill panel*	600-675 mm	600-675 mm
Masonry frame*	N/A	600-638 mm
D-depth	400 mm min.	400 mm min.

* Enclosure dimensions can be larger if using an infill panel or a masonry frame.

Mock chimney

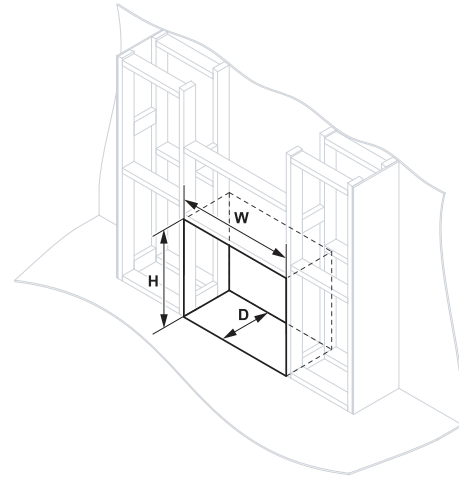

	600	700
W-width	700 mm	800 mm
H-height	700 mm	700 mm
D-depth	400 mm min.	400 mm min.

Framing dimensions above are before the zero clearance frame is fitted.

For mock chimney installations the Ember **MUST BE** installed with the Ember Zero Clearance frame, which gives the required clearances to combustibles.

Corner installations

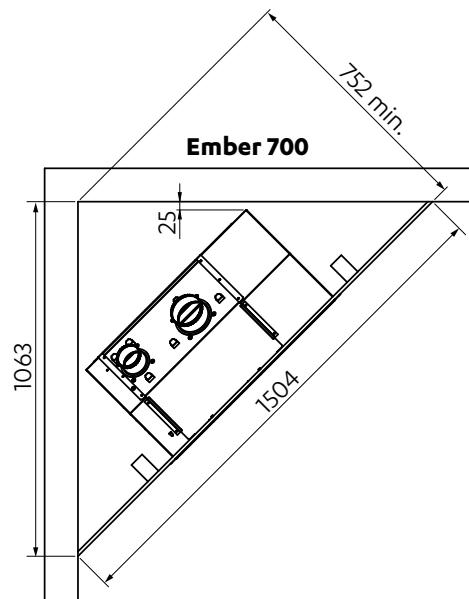
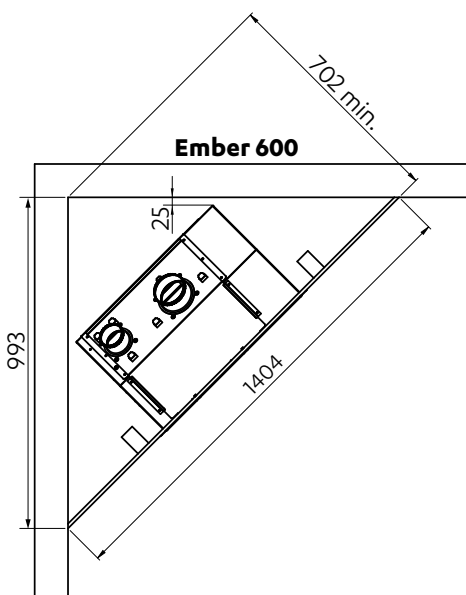

Clearances from combustibles

The clearances listed below, measured from the **edge of the glass**, are minimum clearances unless otherwise stated.

While the heater is operating

The appliance must not be installed where curtains or other combustible materials could come into contact with the heater. The 400 mm side clearance includes side walls. The 1000 mm clearance is in front of the fire.

Floor protection

Heat from this fire may over time affect the appearance of some materials used for flooring, such as, carpet, vinyl, cork or timber. This may be amplified if the air contains cooking vapours or cigarette smoke. To avoid this occurring, it is recommended that a mat be placed in front of the appliance.

Mantels and surrounds

Combustible mantels and surrounds require clearance from the unit to minimise the risk of fire. Mantels and surrounds, made of combustible materials such as wood, are allowed providing they are outside the minimum clearances shown.

Hearths

A hearth is not necessary but can be used for decorative purposes or protection of sensitive flooring if required. A hearth must not obscure the front of the fire or obstruct the fire in any way (including the frame around the fire).

Wall surface above the fire

The temperature of the wall surface directly above the fire may get warm and distort paint finishes, or distort vinyl wall coverings. For durability of surfaces, please contact the manufacturer for their specification.

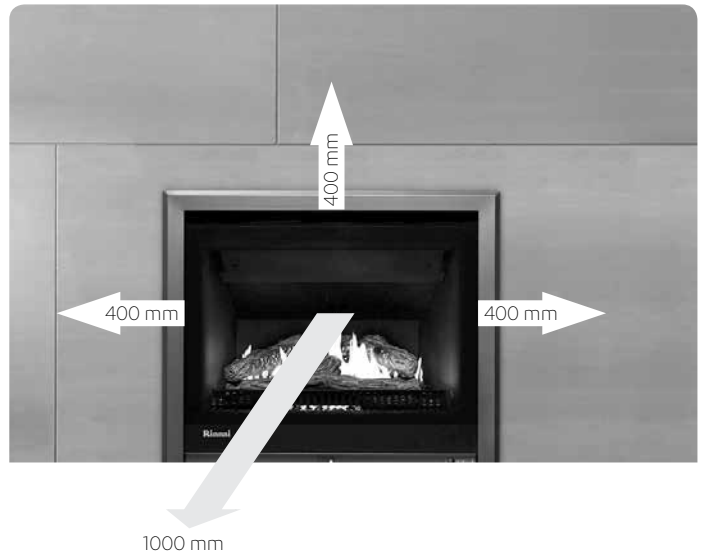

- A** Mantel needs to be a min. of 400 mm away from the edge of the glass.
- B** Max. mantel depth at 400 mm (A) is 250 mm max.
- C** Surround needs to be a minimum of 400 mm away from the edge of the glass.

For every 50 mm of added mantel depth there must be an additional 100 mm of clearance from the edge of the glass. For example:

MANTEL DEPTH	A: CLEARANCE REQUIRED
300 mm	500 mm
350 mm	600 mm
400 mm	700 mm

The below diagrams are to assist people in determining the clearance area around the Ember without having the unit on site. The 4-sided frame is shown as this is the frame used in mock chimney installations, which typically have mantels and surrounds made of combustible material. The 4-sided frame sits approximately 26 mm below the engine, refer dimension diagrams.

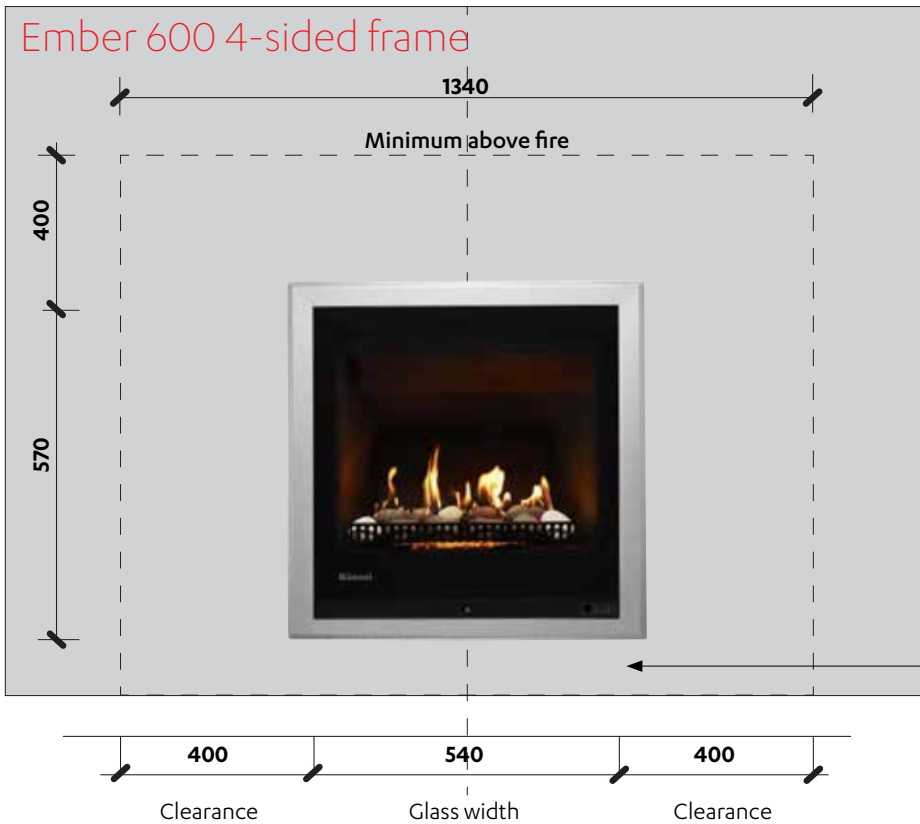

Distance off the floor could be 0-400 mm.

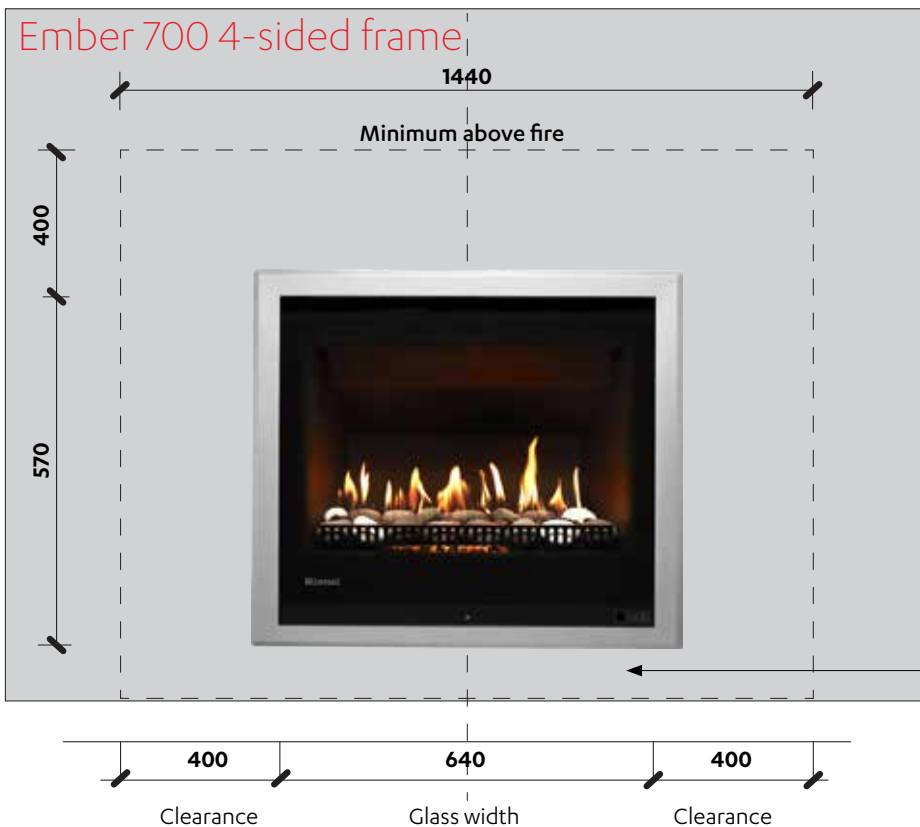

TV installation

The Ember has a fan that distributes warm air from the top of the appliance out into the room. As warm air is dispersed outwards, as opposed to directly upwards, installation of a TV may be an option.

The diagram shows recommended clearances when installing a TV directly above the Ember, or into a recess. All dimensions are in millimetres.

400 mm dimension

The 400 mm dimension is the minimum clearance required to a mantel. The image adjacent shows the dimension from the edge of the frame, in the case of the Ember the 400 mm dimension is to be taken from the edge of the glass.

Always check with the TV manufacturer

It is up to the owner to check the TV installation with the TV manufacturer—some have warranty conditions that state a TV is not to be installed above a fireplace.

Rinnai does not accept any responsibility for damage to a TV resulting from the use of this information.

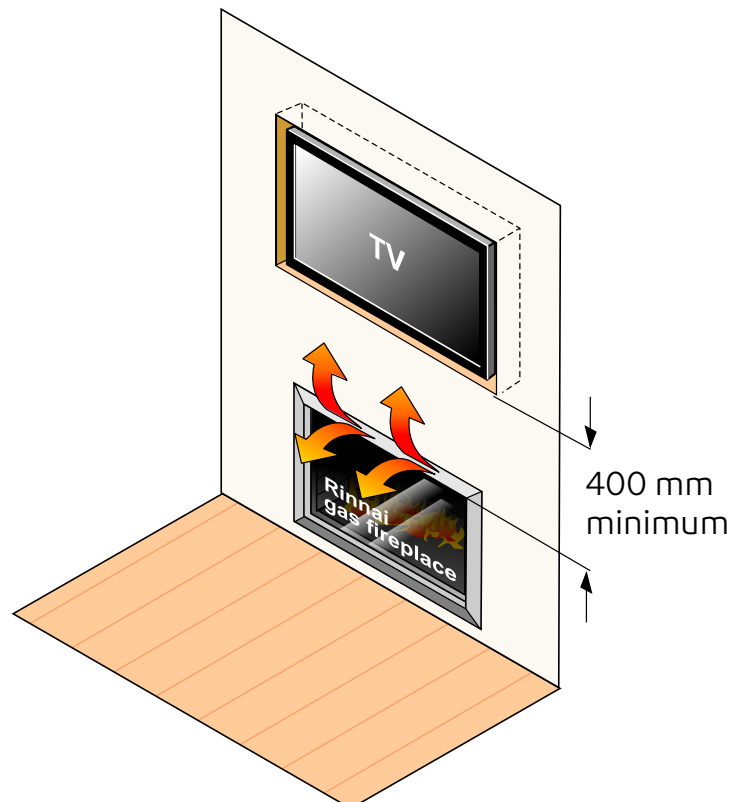
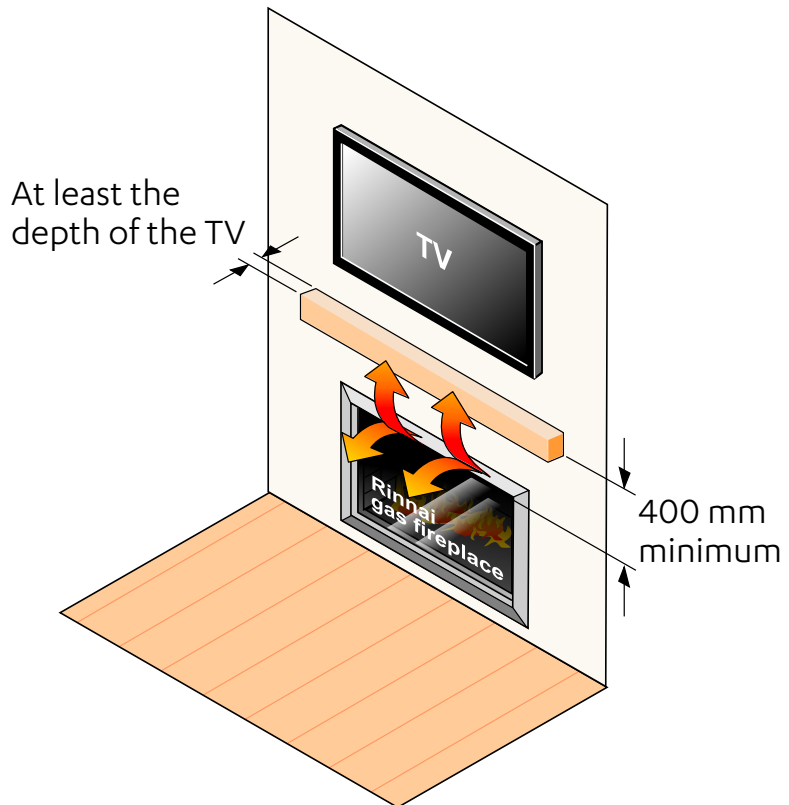

Installation

Installation, servicing and repair shall be carried out only by authorised personnel.



Ember masonry installation overview

1

Modify the enclosure

Ensure the enclosure meets the requirements set out on p. 9.

2

Gas and electrical connections

Prepare gas and electrical connections, refer p. 8.

3

Connect flexi to flue terminal

Stretch out the flexi to the required length and attach to the flue terminal using the clamps provided. Seal the terminal to the chimney plate and weatherproof any openings using appropriate silicone sealant.

4

Drop flexi down chimney

Drop the flexi flue down the chimney, making sure you have the intake and exhaust flues in the correct position, and seal the chimney plate to the chimney.

5

Attach flexi flues to the flue spigot plate

Undo the two front screws holding the flue spigot in place and attach the flexi to the spigot using the clamps provided. Screw/rivet in place to stop any movement, refer p. 19.

6

If using the infill panel or masonry frame attach the side brackets

Attach the side brackets provided with the infill panel or masonry frame, using the screws provided, to the Ember engine using the top and bottom fixings.

7

Attach flue to the fire

Line up the spigot plate with the flue guide rails on top of the unit, slide the unit in place, and secure spigot—two front screws.

8

Secure Ember to the enclosure

This can be done two ways depending on the installation:

1. Secure to the enclosure via the existing flanges on the engine, or
2. If using the infill panel or masonry frame, attach the side brackets* to the Ember engine with screws*, using the top and bottom fixings. Slide the Ember in place, and secure the side brackets to the enclosure, using the three outer screw positions on each bracket, to the brickwork using suitable fixings (not provided).

* Provided with the infill panel or masonry frame

9

Complete the gas connection

Make the gas connection.

10

Install the burn media and commission

Install the glass, granules, rockwool, logs or stones. Refit the combustion chamber glass and commission, refer p. 20-26.

11

Install the frame and infill panel (if using)

Install the masonry or the 3-sided frame and infill panel* (if using), refer p. 27.

* Separate installation instructions are provided with the infill panel.

Check the size of the chimney before doing anything. It needs to be at least 200 x 200 mm for the colinear flexi flue to fit down.

When dropping the flexi flue down the chimney make sure you have the intake and exhaust flues in the correct position. The intake is on the left.



Make sure the chimney cap is weathertight. Flexi flue also needs to be secured to the flue cowl using the clamps provided—these need to be riveted/screwed in place to reduce the risk of movement.



Intake Ø 75 mm left hand side.

Exhaust Ø 100 mm right hand side.

Maximum flue length is 8 m.

The Ember engine must be secured to the enclosure via the top and side flanges. This can be done directly into the enclosure, into the infill panel or masonry frame using the side brackets provided.

Flexi flues clamped and riveted/screwed in place to the engine spigot plate. Due to the weight it's best to support the underside of the plate to stop the flexi flues from extending too much.



Base of masonry enclosure **MUST BE** level and allow free movement of the appliance for maintenance and servicing.

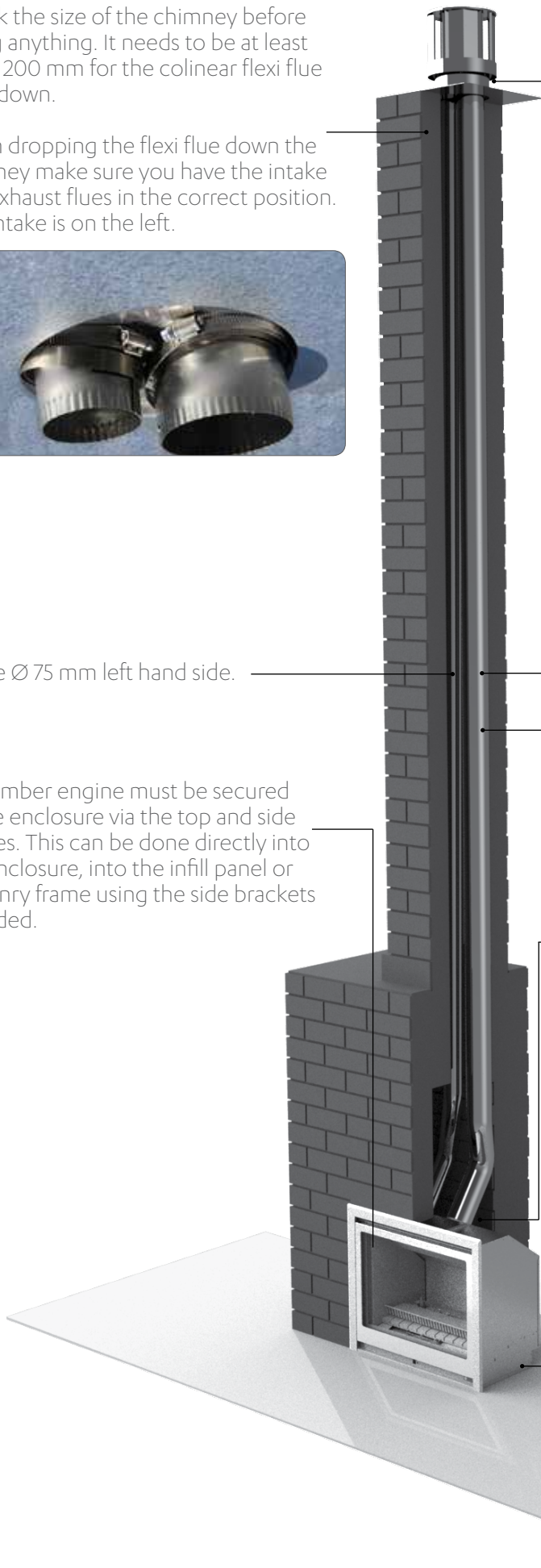

Ember mock chimney installation overview

- 1 Modify the enclosure**
Ensure the enclosure meets the requirements set out on p. 9.
- 2 Gas and electrical connections**
Prepare gas and electrical connections, refer p. 8.
- 3 Install the zero clearance frame**
Install the zero clearance frame into the enclosure and fix in place with the screws provided. This frame is critical and must be installed as it automatically gives the required clearances to combustibles. Refer p. 18, and frame kit installation instructions.
- 4 Flue system installed**
Install the coaxial* to colinear adaptor. Ensure it is self supported with the frame and screwed in place. Attach the intake and exhaust flexi flues to the adaptor, clamp and screw into place—check clearances are maintained. Add colinear sections as required, these twist and lock into place.
- 5 Attach flexi flues to the flue spigot plate**
Undo the two front screws holding the flue spigot in place and attach the flexi to the spigot using the clamps provided and screw into place, refer p. 19.
- 6 Attach the flue spigot back onto the engine**
Line up the spigot plate with the flue guide rails on top of the unit, slide the unit into place, and secure the spigot—two front screws.
- 7 Secure Ember to the zero clearance frame**
Secure engine to the zero clearance frame—nine screw positions (three LHS, three top, and three RHS).
- 8 Complete the gas connection**
Make the gas connection.
- 9 Install the burn media and commission**
Install the glass, granules, rockwool, logs or stones. Refit the combustion chamber glass and commission, refer p. 20-26.
- 10 Install the frame**
Install the frame, refer p. 27.

* Can't be more than 600 mm maximum due to the heat from the colinear flexi flues.

Self-supporting coaxial flue; inner $\text{\O}100$ mm, outer $\text{\O}170$ mm. Requires 10 mm clearance to a combustible surface. Flue pipes twist and lock into place.



Flue cowl needs to a 500 mm clearance from the nearest ridge line of the roof. In this instance the flue pipe has been painted to match the roof.



Colinear to coaxial adaptor supported and secured in place. Flexi flues clamped and screwed to the connections.



Maximum vertical flue length is 10 m. If adding 2 x 45° bends (maximum number of bends), then the flue length reduces by 2 m, refer p. 34.

Zero clearance frame fitted, refer next page



600 mm maximum

Base of enclosure **MUST BE** level and allow free movement of the appliance for maintenance and servicing.

Installing the zero clearance frame (R2450)

For mock chimney installations the zero clearance frame is a mandatory requirement to ensure a safe installation for the homeowner. The zero clearance frame is fitted prior to final cladding. It is a universal frame, designed for different opening sizes.

For installation refer to the detailed instructions provided with the zero clearance frame kit.

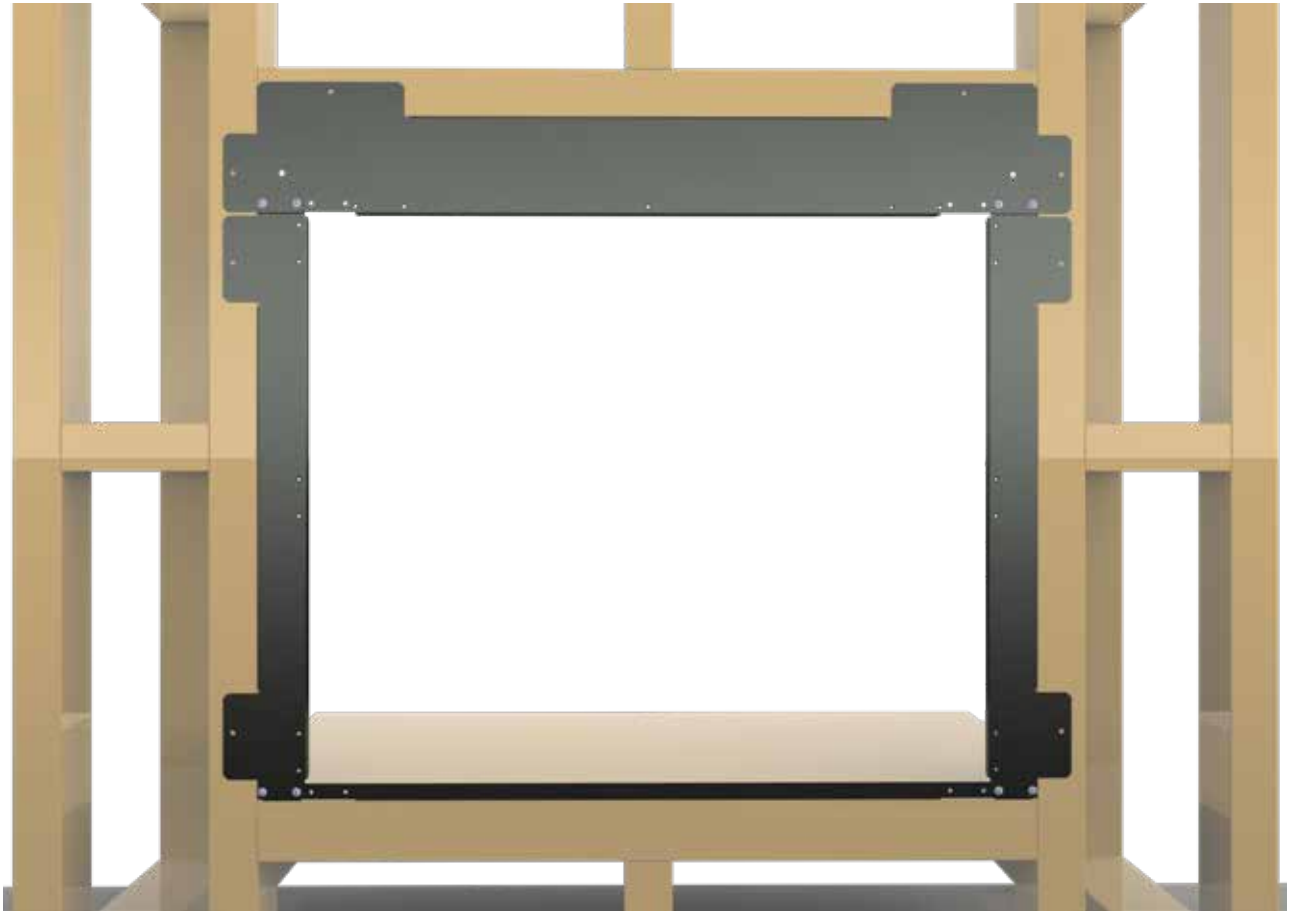

The frame has three functions:

1. Maintains the required clearances to combustibles around the fire.
2. Keeps the enclosure square, and provides rigidity above the fire.
3. Allows for a thin profile frame, and for the engine to slip easily in and out of the enclosure.

Attaching the flexi flues to the spigot plate

The flexi flues need to be securely fixed to the engine spigot plate using the clamps provided. To do this the spigot plate needs to be temporarily removed from the engine—undo the two front screws holding it in place.

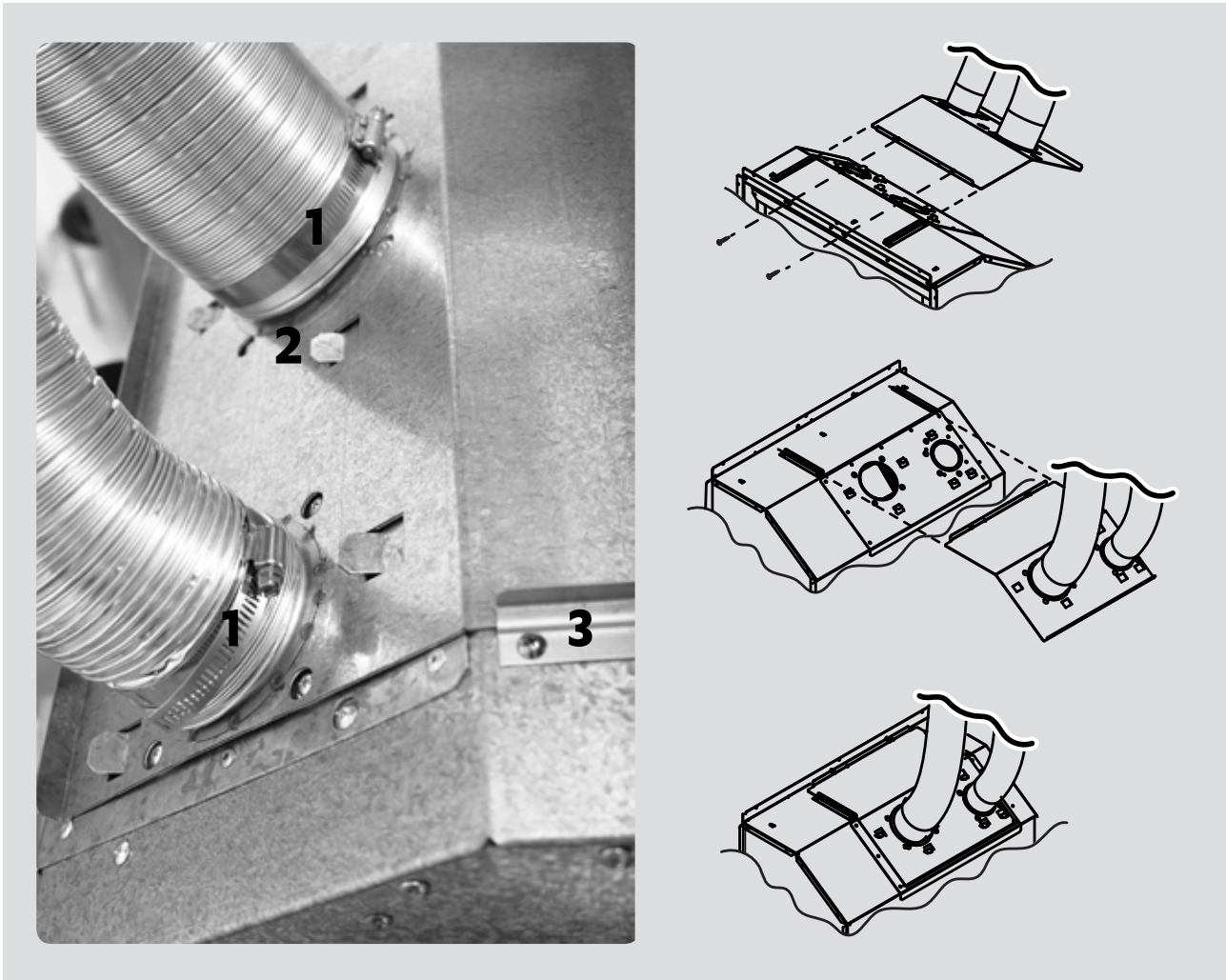

1. Flue clamp holding the flue onto the spigot plate.
Important: This also needs to be screwed/riveted in place to stop any movement of the flue.
2. Tabs to hold the plate in place.
3. Flue guide rail in either side of the engine. The spigot plate slides in and out of this.

Helpful tip

Once the flue is connected to the spigot plate it will be free-hanging. To avoid damage to the flue it's best to support this within the cavity while waiting to install the engine.

Burn media installation



Experience has shown that the majority of performance problems are caused by burn media being installed incorrectly. Please take the time to read and follow these instructions as malfunctioning due to incorrect burn media placement is not covered by warranty.

The Ember **MUST NEVER** be used with other burn media or burn media that is damaged.

Ember 600/700 burn media sets - they are different and can't be interchanged

The Ember 600 and 700 burn media sets are different. The Ember 600 stone set has six less stones and the log set is narrower and shorter—ensure you have the correct kit before starting.

Ember 600 log set

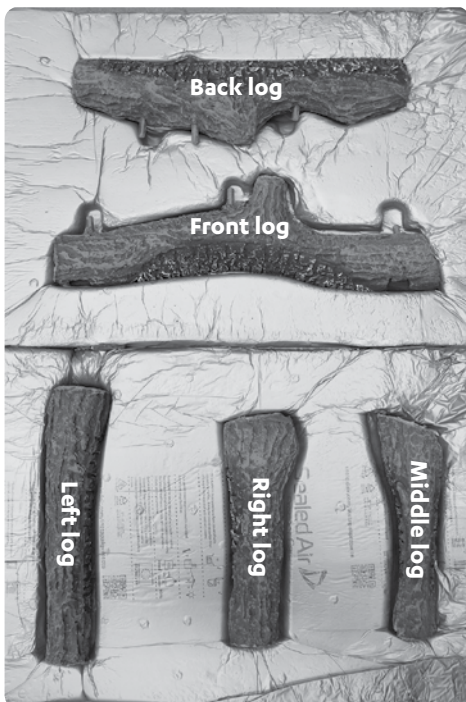

Ember 700 log set

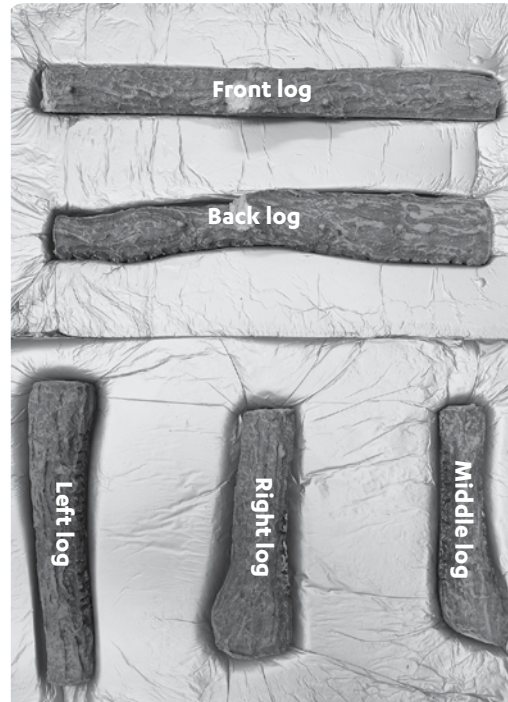

Ember 600 stone set - laid out in the correct order



Ember 700 stone set - laid out in the correct order



Positioning guide picture fixed to the unit will help

There should be a wonderful closeup picture secured to the fire to help you decipher what goes where. Use this in conjunction with these instructions to help with the installation.

Adding the glass and vermiculite

This step is common to both models and both types of burn media. It requires removing the upper burn media tray to access the mesh holding tray.

1. Unscrew the left and right tray screws to lift off the upper mesh holding tray.
2. Carefully empty the bags of vermiculite and glass into the mesh tray, **blend** together and level out.
3. Put the upper tray back in place and re-tighten the screws.



Log set installation

The log set is packaged separately and consists of five log pieces. Use extreme care when handling the logs, they are made from fragile material and will damage easily.

While the log set for the Ember 600 and 700 are different (Ember 600 is smaller), the installation steps are the same—the 700 has been used in these instructions.

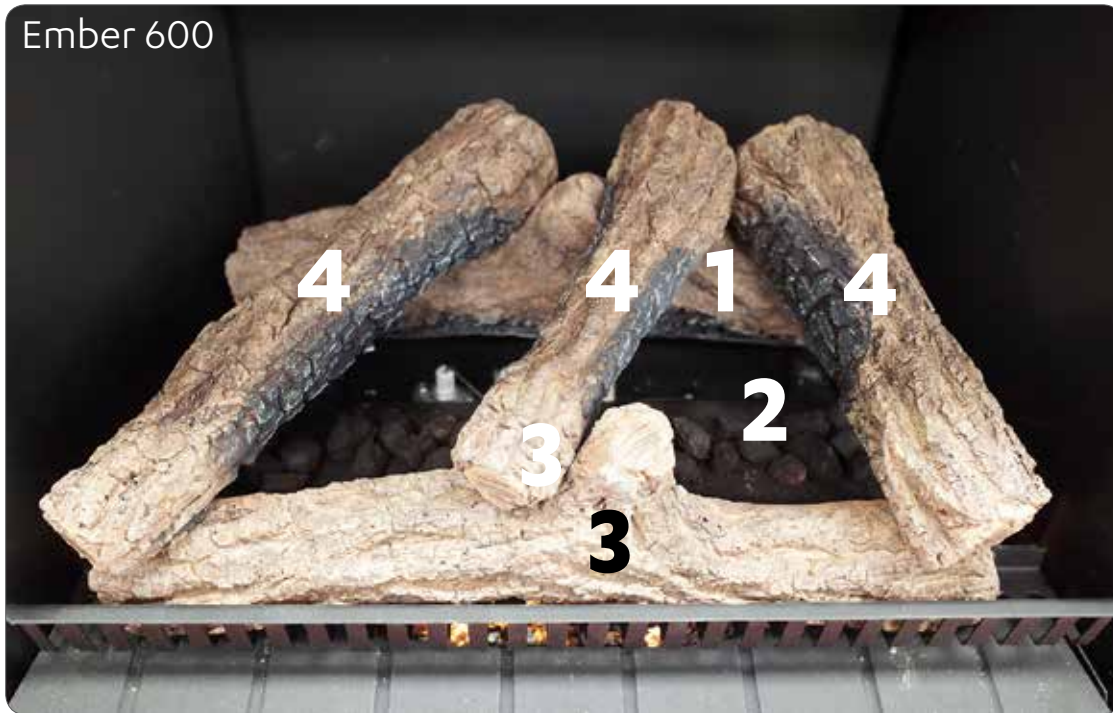

Before adding the log set make sure the vermiculite and glass packets have been added into the burn media tray (refer previous page), and that it has been secured back in place. All the logs have locating pins making it possible to only fit one way onto the burner.

Step 1: Back log

Place the back log onto the two log location brackets at the back of the burner. The charred side faces to the front.



Step 2: Adding the granules and rockwool

Place, DO NOT POUR, the granules, ensuring even coverage around the burner ports (so as not to cause blockages). For the 700 you will need both granule packs, for the 600 it's about a bag and three quarters. Pinch and roll the rockwool into pea-sized balls (600 ≈ 35, 700 ≈ 50) and place in-between the granules. These can go over the burner ports as the material is designed for the flame to penetrate through the ceramic fibres to enhance the flame picture and produce a glow effect.



Step 3: Front log

Add the front log onto the two log locating pins inside the grill. It should sit securely into the gap.



Step 4: Top three logs

Add the three top logs onto the locating pins of the back and front logs—refer photos on previous page. Underneath each log is a hole (front position) and a slot (back position).

Stone set installation

The stone set is packaged separately. Use extreme care when handling the stones, they are made from fragile material and will damage easily. While the stone sets for the Ember 600 and 700 are different (Ember 600 has six less stones), the installation steps are the same. Refer to p. 20 for the correct installation order.

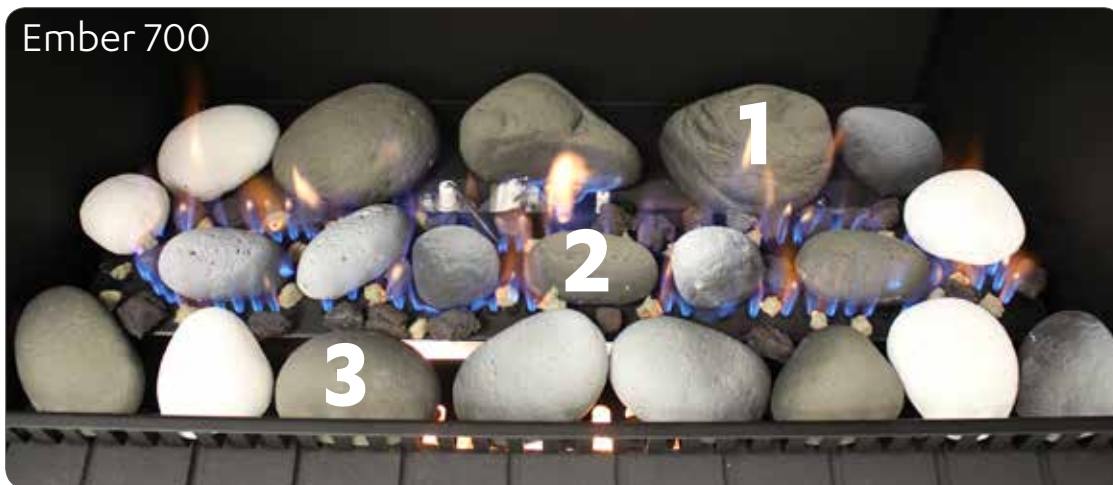

Before adding the stone set make sure the vermiculite and glass packets have been added into the burn media tray (refer p.21), and that it has been secured back in place. Also remove the two back log locating pins and bracket (not needed for the stone set)—replace the black screws holding the bracket back into the burner.

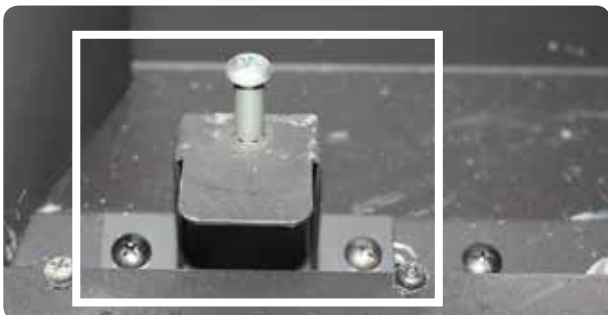

Back log location pin and bracket

Step 1: Back row of stones

Place the back row of stones as shown.



Step 2: Middle row of stones

Place the middle row of stones BETWEEN the burner ports as shown.



Step 3: Front row of stones

Add the front row of stones inside the grill. A few of these will be angled slightly to cover the front of the burner bed.



Step 4: Adding the granules and rockwool

Place, DO NOT POUR, the granules, ensuring even coverage around the burner ports (so as not to cause blockages). You will use approx. one bag of granules for both models (a bag will be leftover). Pinch and roll the rockwool into pea-sized balls (600 \approx 20, 700 \approx 30) and place in-between the granules. These can go over the burner ports as the material is designed for the flame to penetrate through the ceramic fibres to enhance the flame picture and produce a glow effect.



Commissioning

The gas pressures must be checked against those printed on the data plate of the appliance. The pressures are factory set and may not require adjustment. When checking the operating pressures the combustion chamber glass must be on.



Commissioning sheet (and small 19 mm spanner) located on top of the PCB cover

The commissioning sheet, and a 19 mm small spanner for the gas connection, is located in a plastic pouch inside the unit on top of the PCB cover.

Follow the commissioning instructions to complete the gas pressure checks. When commissioning is complete check for full and correct operation of the appliance, and return the commissioning sheet to its plastic pouch.

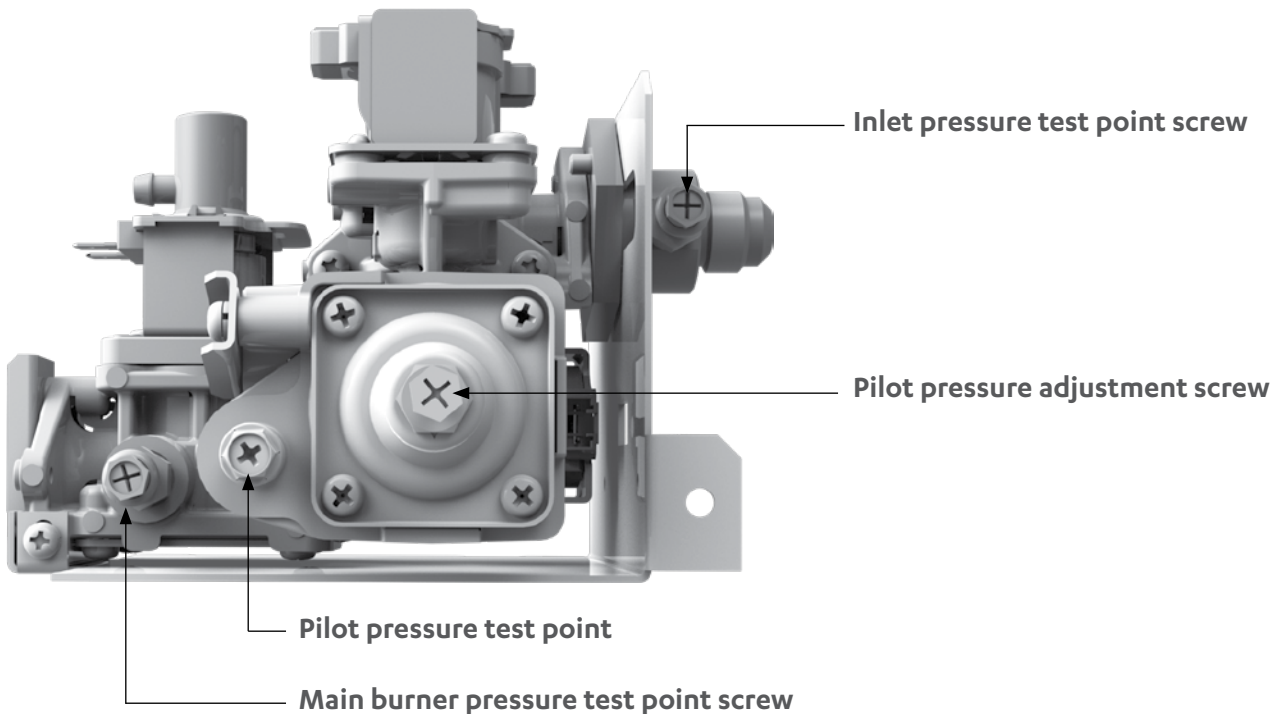

Installing the frame

Easy four stage process, which will be the same regardless of frame type, for example 3-sided frame, 4-sided frame, or the 700 masonry frame.

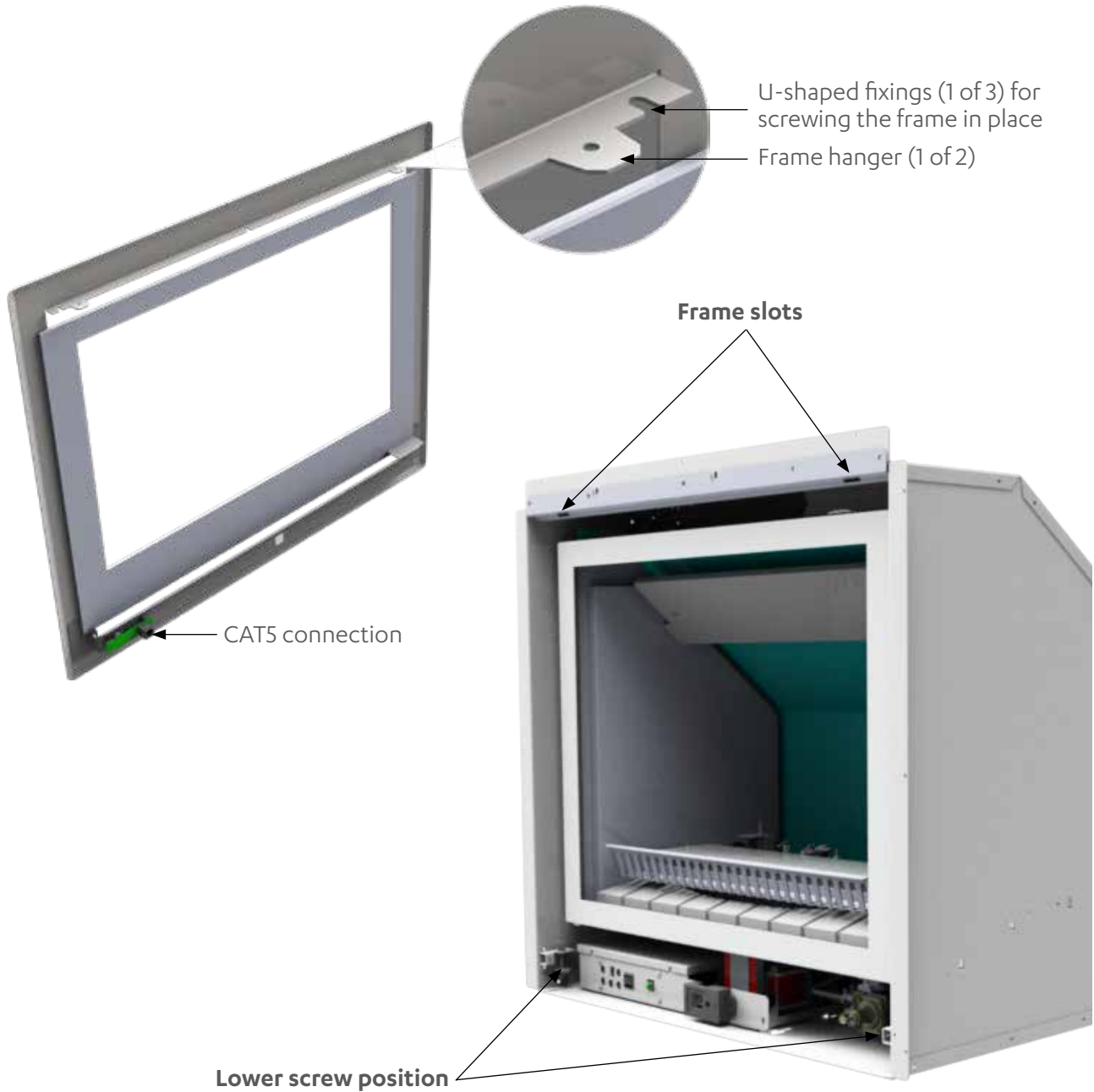

1. Position the frame assembly in front of the engine and connect the CAT5 cable to the frame. This connects the push button control panel to the engine's box.
2. Slide the two top frame hangers into the corresponding frame slots on the Ember engine and push the lower section into the recess of the engine.
3. Secure the top section in place, using the screws provided, via the three U-shaped fixing positions on the frame.
4. Secure the lower section of the frame in place using the two bottom side screws.

Test operation and lighting sequence

It may take approximately two hours of operation for the burn media to achieve their full flame pattern and glow. During the initial burning in period, some smoke and smell may be experienced. The appliance should run on the high setting in a well ventilated room until these dissipate. It is important to check the flame pattern during this time.

Abnormal flame pattern

Abnormal flame performance and/or pattern can indicate a problem with your fire, such as blocked gas injectors, or that the burn media has shifted. There are some warning signs that could indicate a problem.

- Unusual smell from the appliance
- Continued difficulty or delay in establishing a flame
- Flame appears either very short or very long
- Flame only burns part way across the burner
- Severe soot building up on the inside of the glass door

Important

It is the responsibility of the installer to check that under normal conditions of the appliance, all flue gases are exhausted to the outside atmosphere, and that there is no spillage of combustion gases into the room.

If the appliance cannot be made to perform correctly please contact Rinnai.

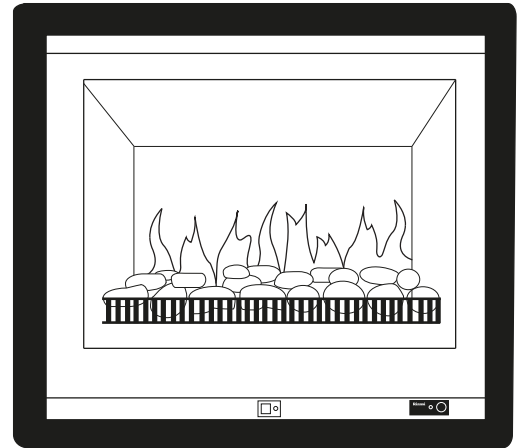

Normal flame pattern

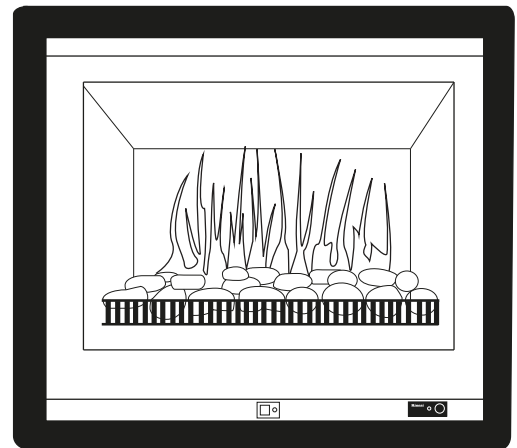

Abnormal flame pattern

Installation checklist and customer handover

Complete the installation checklist in the customer operation guide, and make sure you leave the guide with the customer. Add a touch of magic by taking the time to explain to the customer about the use and care of the unit, and that they understand the instructions.

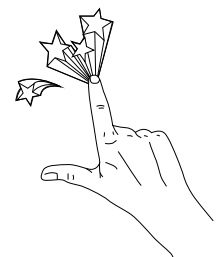

Wiring diagram (part of commissioning)

Mark	Part
B	Burner
ER	Electrode
F	Fuse Electrical
FM	Convection Fan Motor
FR1-2	Flame Rod 1-2
L	Light
OH.TH1	Over Heat Thermistor
PB	Pilot Burner
POV	Modulated Solenoid Valve
R.TH	Room Thermistor
RCR	Remote Control Circuit
SP	Sparker
SV1-3	Main Solenoid Valve 1-3
TF	Thermal Fuse
TR	Transformer

Mark	Colour
bk	black
bl	blue
gr/y	yellow-Green stripe
gy	grey
or	orange
pl	purple
r	red
w	white
y	yellow
p	pink
br	brown

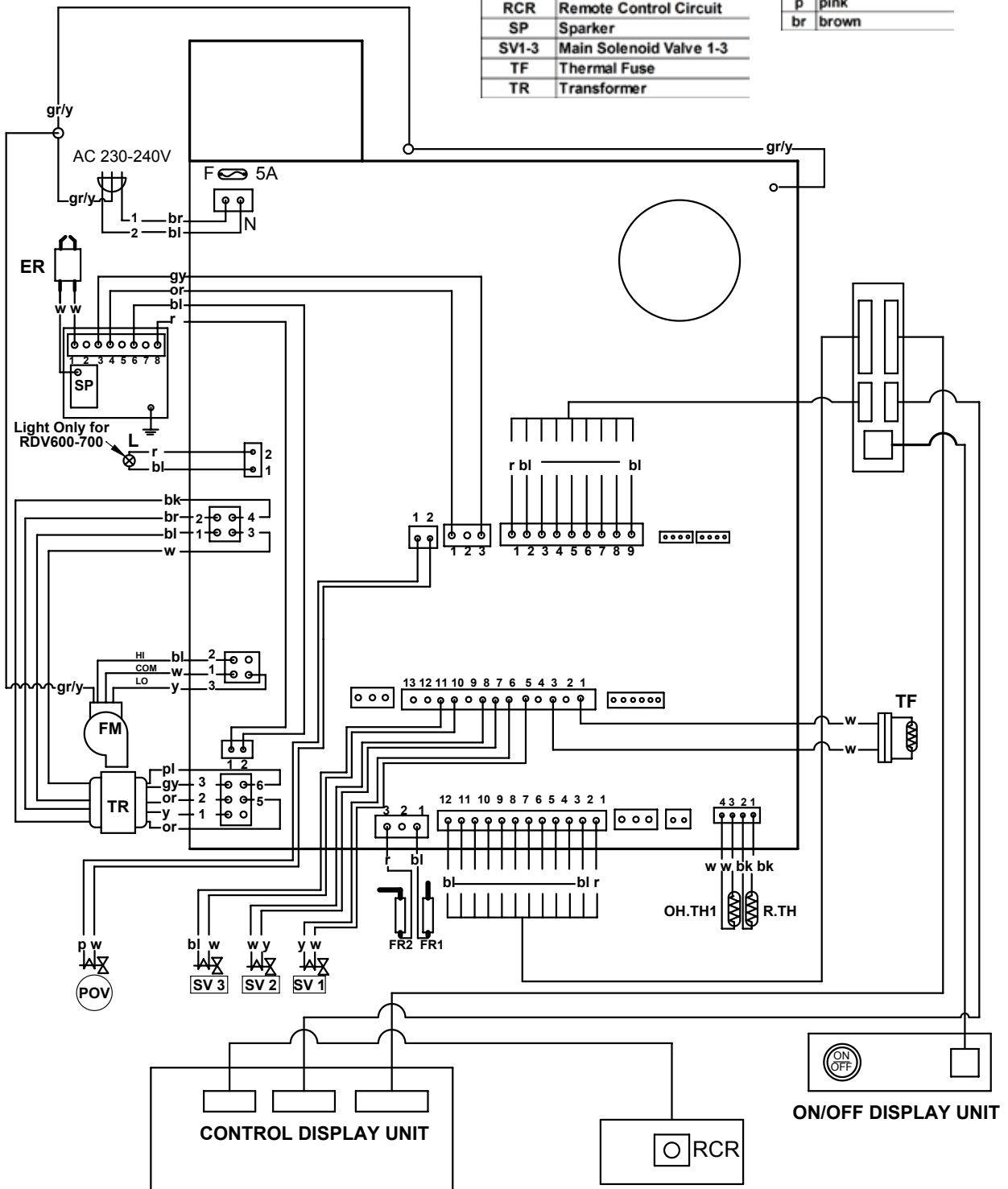

WIRING DIAGRAM UNI CONTROL MODEL 3
1 Burner
Issue B

Ember flueing

Every gas fire requires a flue system that will draw effectively and clear flue products safely under all potential wind and climatic conditions. It is the responsibility of the installer to ensure the appliance is provided with an effective flue.

Some guidelines to assist with flue design are detailed below. These must be read and modified as necessary depending on the installation. The Ember must be installed with an approved flue system, approved components are shown in this guide.

General flueing guidelines

Flue clearance to combustibles

Flueing for the Rinnai Ember, depending on the installation is comprised of three main components:

- flexible aluminium flues that come straight off the fire
- galvanised steel colinear to coaxial adaptor (stainless steel inner)
- galvanised steel outer, aluminium inner coaxial flue

These all have slightly different clearances to combustibles.

Flue cowl clearance

To ensure products of combustion are cleared, adequate clearance from the building is required.

The flue cowl should have a 500 mm clearance from any part of the building. This also applies to steeped and pitched roofs where the flue cowl should be 500 mm clear of the ridge line. An adequate flow of fresh air must exist around the flue cowl following installation.

Minimum clearances are shown in AS/NZS 5601.1.

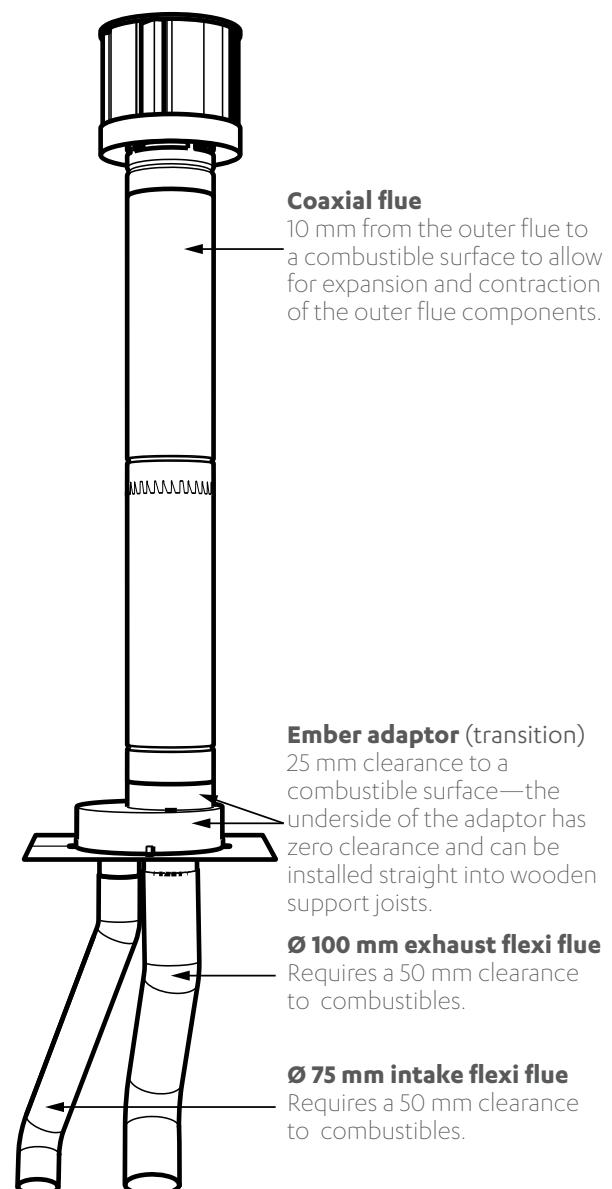

Flue terminal locations

Flue terminals must be compliant with the flue terminal locations shown in AS/NZS 5601.1.

The flue cannot terminate under a floor or in a roof space.

Self-supporting flue

The weight of the flue system should not be supported by the appliance—it should be self-supporting.

Supporting the flue is usually completed during the framing stage with flue supports or straps within the cavity. Wall straps have been included in the Rinnai vertical flue kits. Elbow straps are also available as a separate component to prevent excess weight on the flue elbow.

Horizontal runs of flue pipe

Horizontal runs of flue pipe must be supported to prevent any downward sags. Horizontal pipe sections should be supported every 1.2 m. Wall straps can be used for this purpose.



The horizontal run of flue pipe must have a 20 mm rise for every 1 m of run towards the flue termination, NEVER allow the flue pipe to run downwards towards the horizontal flue terminal. A downward slope can trap heat and become a fire hazard.

Shared flues

Gas appliances must not be connected to a chimney or flue serving a separate fuel burning appliance.

Flashings

Flashings are not included with the Ember flue kits, these must be specified. The only exception is the flashing kit provided in the horizontal flue kit.

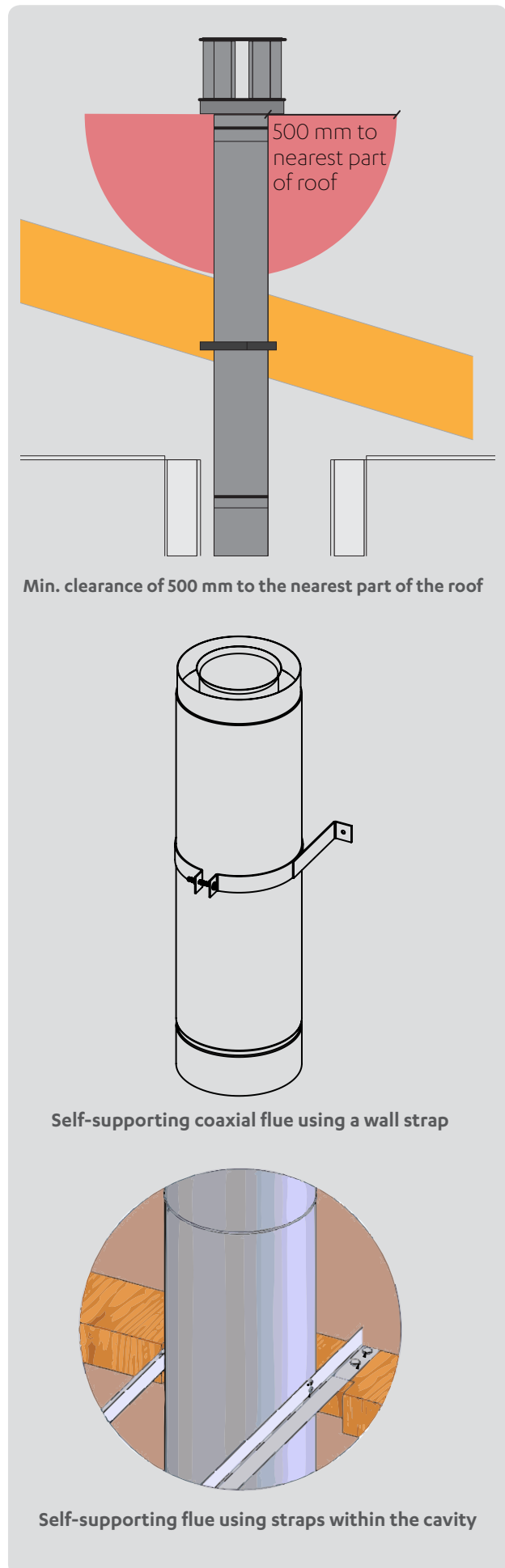

Flueing options

Mock chimney - direct horizontal

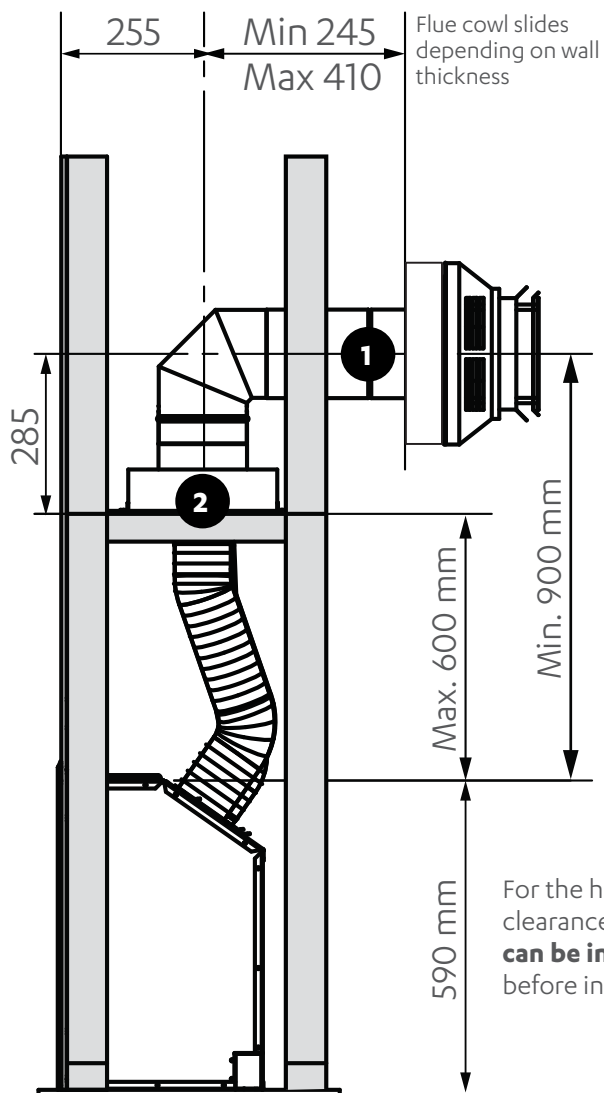

Flue components

- 1 **Mock chimney horizontal flue kit (R3654)**
- 2 **Ember adaptor (R3653)**
Refer p. 30 for clearance to combustible information for the Ember adaptor.

Maximum length can't be more than 600 mm due to the heat from the colinear flexi flues.

For the horizontal flue terminal to comply with the required flue clearances, and to fit under a 2.4 m eave, the **maximum the fire can be installed above the floor is 400 mm**. Check clearances before installation.

Flueing options

Mock chimney - extended horizontal

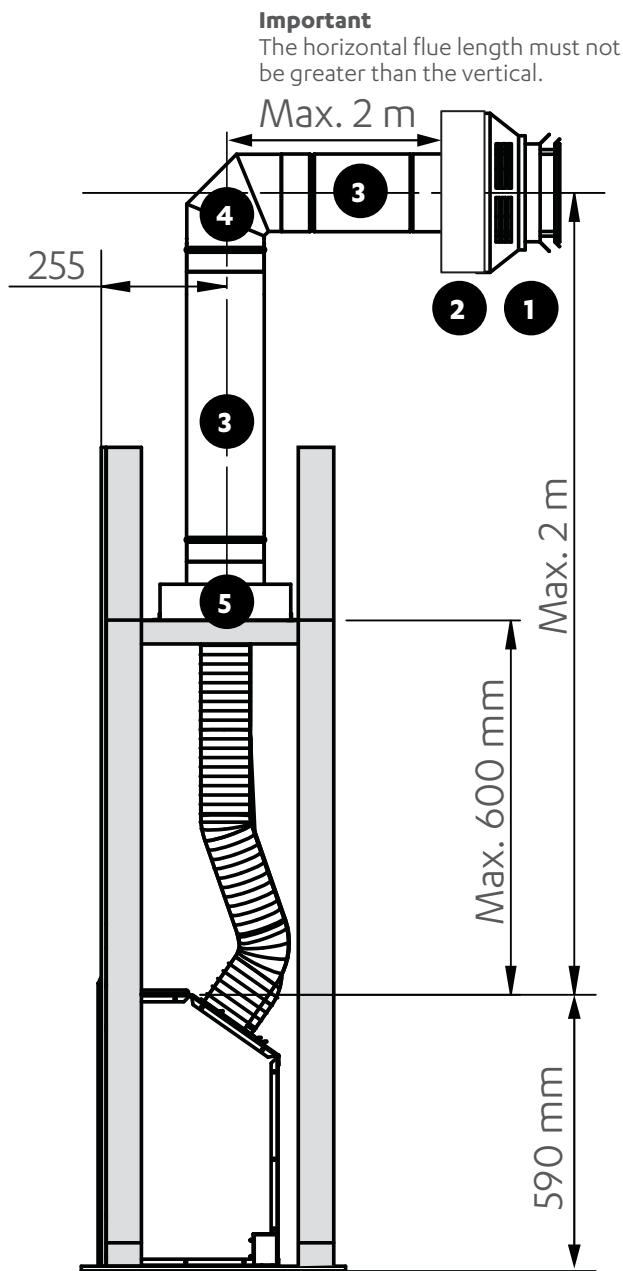

Flue components

- 1 Horizontal wall terminal (R3650)**
- 2 Horizontal flashing kit (R3646)**
- 3 Flue pipe(s) or flue extension**
The horizontal run of flue pipe must have a 20 mm **rise** for every 1 m **towards** the flue termination. NEVER allow the flue pipe to run downwards towards the flue terminal. A downwards slope can trap heat and become a fire hazard.
- 4 Flue elbow 90° (R3643)**
Maximum number of 90° bends is one.
- 5 Ember adaptor (R3653)**
Refer p. 30 for clearance to combustible information for the Ember adaptor.

Maximum length can't be more than 600 mm due to the heat from the colinear flexi flues.

Flueing options

Mock chimney - vertical terminations

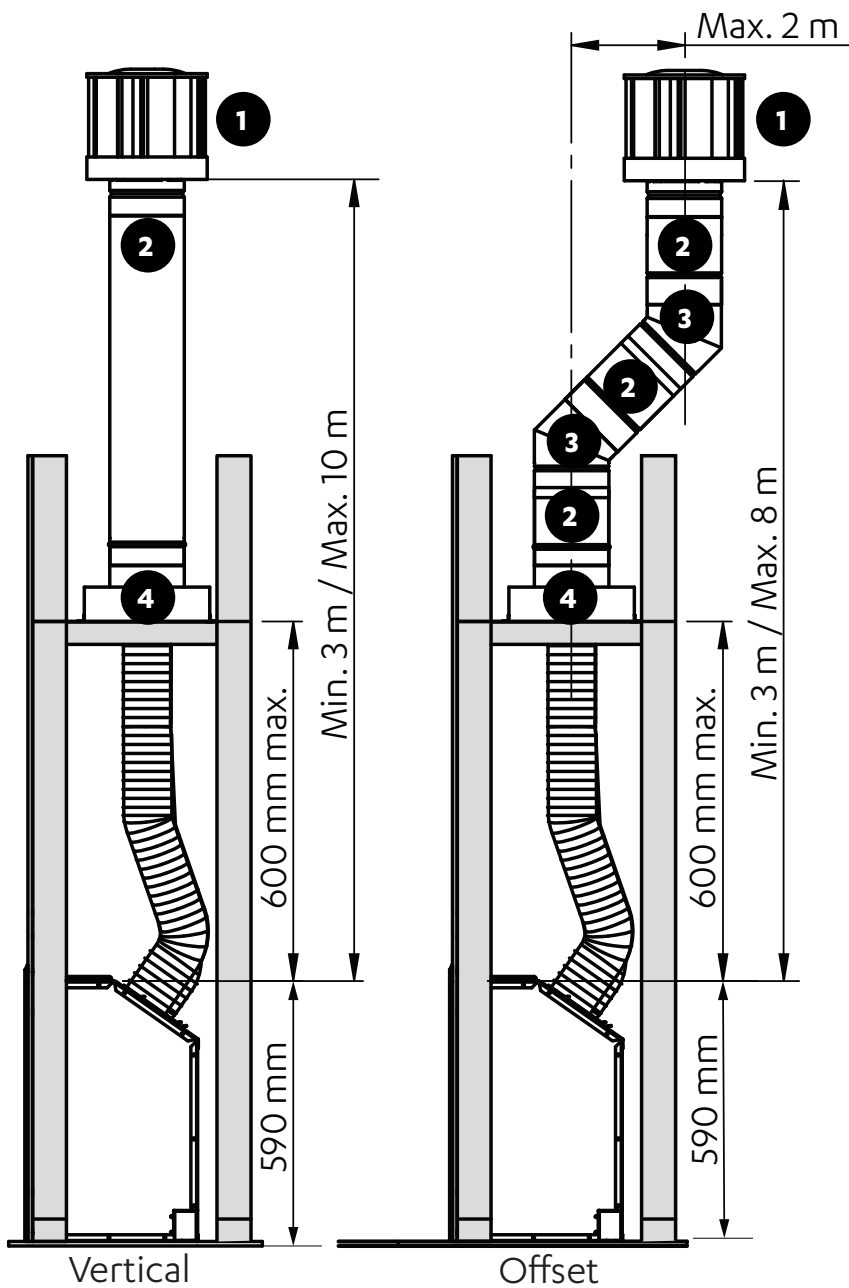

Flue components

- 1 Roof cowl (R3651)**
- 2 Flue pipe(s) or flue extension**
- 3 Flue elbow 45° (R3642)**
Maximum number of 45° bends is two.
- 4 Ember adaptor (R3653)**
Refer p. 30 for clearance to combustible information for the Ember adaptor.

Maximum length can't be more than 600 mm due to the heat from the colinear flexi flues.

Vertical flueing, if doing a short vertical flue, no bends, for a single storey dwelling, the mock chimney vertical flue kit 3.6 m (R3665) can be used.

Flueing options

Non-combustible opening only - vertical termination

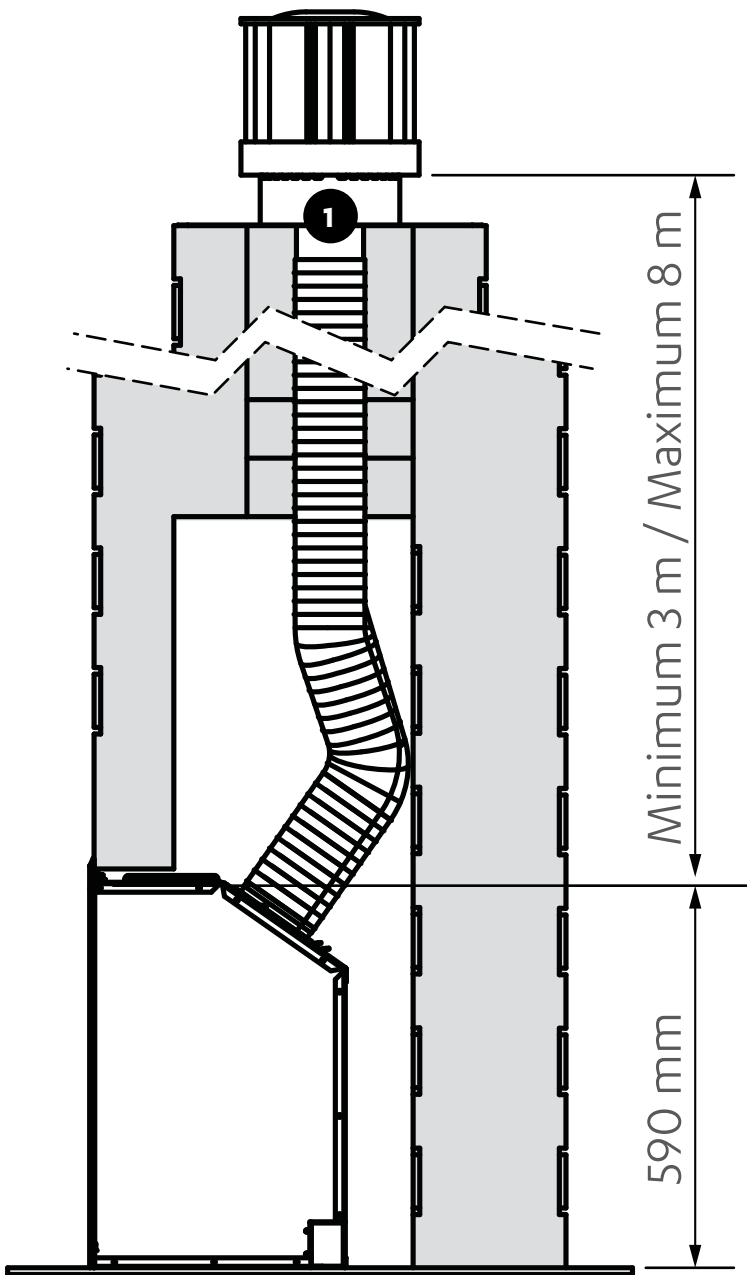

Flue components

- 1 **Masonry chimney flexi vertical flue kit (R3652)**
Extends out to 8 m.

Actual chimney size needs to be at least 200 x 200 mm for the flexi flues to fit down the chimney.

Flueing options

Non-combustible opening only - horizontal termination

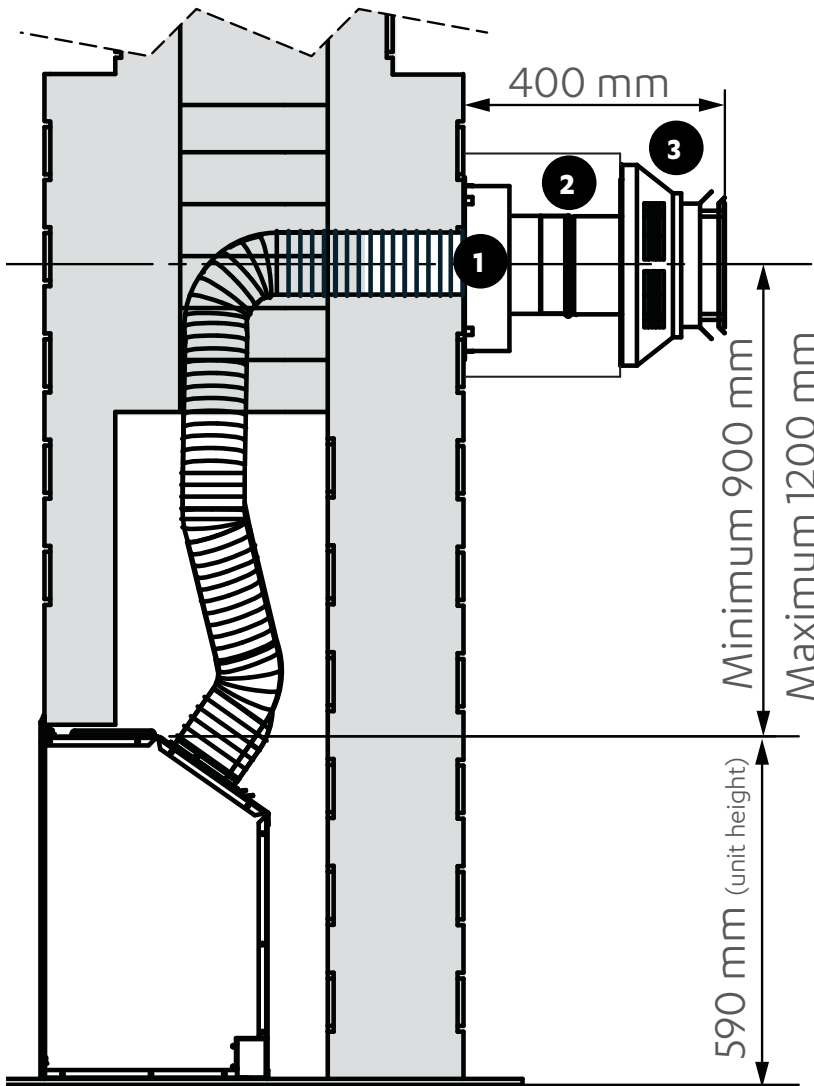

Flue components

- 1 Ember adaptor (R3653)**
Stretches out to 1.2 m.
- 2 Masonry horizontal flue box (R2449)**
- 3 Horizontal wall terminal (R3650)**



Photo of an assembled masonry horizontal flue box and wall terminal

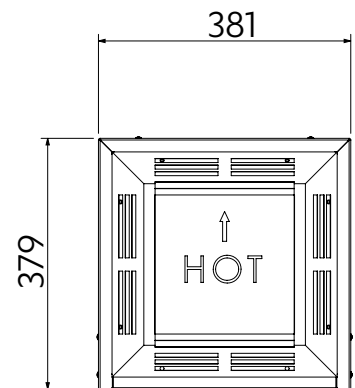
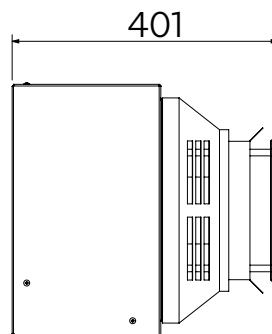
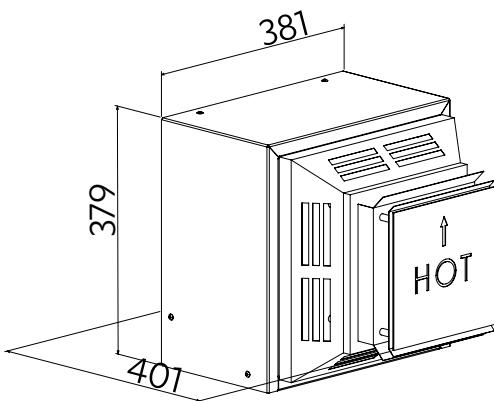

Flue kits and components

Mock chimney vertical flue kit 3.6 m

Code: R3665

Coaxial vertical flue kit that attaches to the Ember Adaptor.

Kit includes; high wind roof cowl, flue pipes 1200 mm x 3, wall straps x 3.

If longer flueing is required, order additional flue pipes.



Mock chimney horizontal flue kit

Code: R3654

Coaxial horizontal flue kit that attaches to the Ember Adaptor.

If longer flueing is required order additional flue pipes.

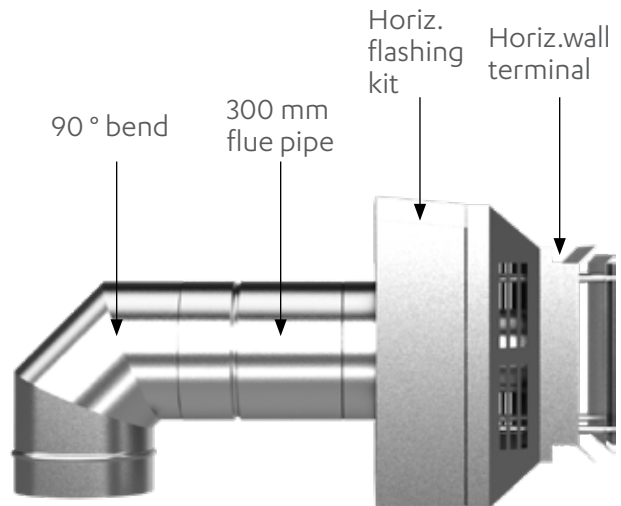

Masonry chimney flexi vertical flue kit

Code: R3652

For installation into a masonry fireplace. Allows the fire to perform more effectively by achieving a better draw. Extends out to 8 m.

Kit includes; flue cowl, chimney flashing plate, intake flexi Ø 75 mm (LHS), exhaust flexi Ø100 mm (RHS).



Masonry horizontal flue box

Code: R2449

Horizontal flue box that joins the Ember adaptor to the horizontal wall terminal. Used in installations where the chimney has been capped off. Refer previous page for detail drawing.

Kit includes; masonry chimney plate, and masonry box.

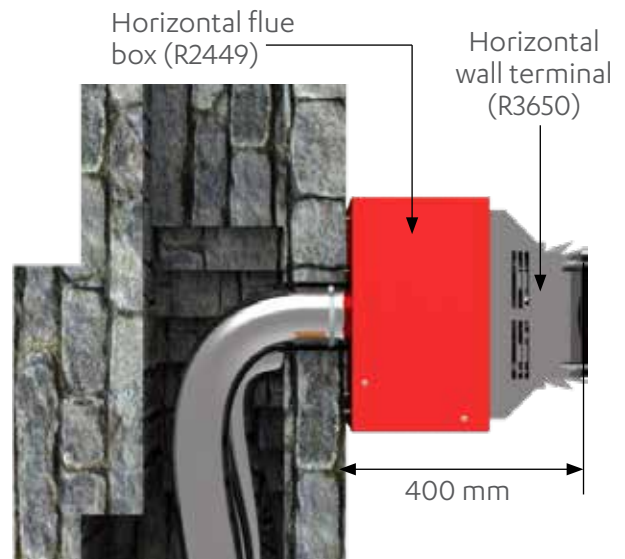

Flue kits and components

Ember flue adaptor

Code: R3653

Colinear to coaxial adaptor. Contains; adaptor, locating plate (455 x 455 mm), Ø 75 mm and Ø 100 mm flexi flues, and four flue clamps. Stretches out to 1.2 m.

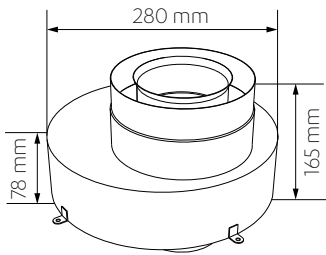
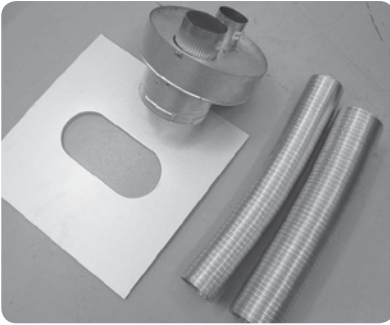

Flue pipes

- 150 mm: R3630
- 230 mm: R3631
- 300 mm: R3632
- 450 mm: R3633
- 600 mm: R3634
- 900 mm: R3635
- 1200 mm: R3636

Pipe used to construct horizontal and vertical flueing. Cannot be cut to size. Once joined nominal length reduces approx. 35 mm.

Inner - aluminium Ø 100 mm
Outer - galvanised steel Ø 170 mm



Flue extension

- 75-175 mm: R3638
- 75-360 mm: R3639

Used for extended straight lengths of flue.

Available in two lengths—extending to 175 mm or 360 mm.

Inner - aluminium Ø 100 mm
Outer - galvanised steel Ø 170 mm



Wall flue strap

Code: R3647

Adjustable strap used to add lateral support to the flue.

Provides a 50-200 mm clearance to combustible walls.



Elbow flue strap

Code: R3644

Flue support for elbows and offsets.



Flue elbow 90°

Code: R3643

Used to facilitate between vertical and horizontal flueing. Elbow swivels 360° at base.

Once joined effective length reduces 35 mm to approx. 130 mm.

Inner - aluminium Ø 100 mm
Outer - galvanised steel Ø 170 mm



Horizontal flashing kit

Code: R3646

Flashing components used to join the internal flue to the outside flue—to provide a weathertight seal in horizontal flue installations. Refer horizontal wall terminal for installed dimensions. Box depth is 100 mm.

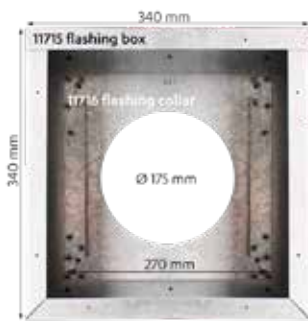

Horizontal wall terminal

Code: R3650

Aluminium flue terminal required for all horizontal terminations.

Depth with horizontal flashing kit installed—252 mm.



Roof cowl

Code: R3651

Aluminium flue terminal required for all vertical flue installations—part of all vertical flue kits.

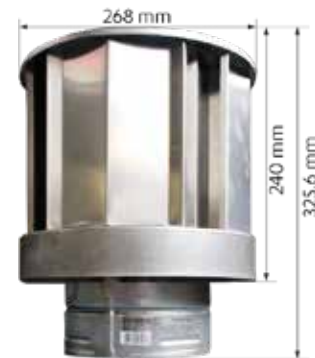

Flue elbow 45° (x2)

Code: R3642

Offsets obstructions.

Elbow swivels 360° at base.

Once joined effective length reduces 35 mm to approx. 73 mm.

Inner - aluminium Ø 100 mm
Outer - galvanised steel Ø 170 mm

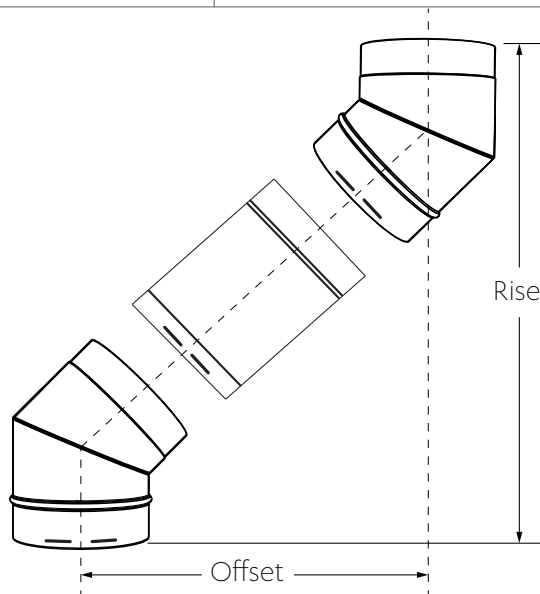

Flue pipe (length and code)		Offset	Rise
None (bend to bend)	N/A	124 mm	340 mm
150 mm	R3630	203 mm	419 mm
230 mm	R3631	257 mm	473 mm
300 mm	R3632	311 mm	527 mm
450 mm	R3633	417 mm	633 mm
600 mm	R3634	524 mm	740 mm
900 mm	R3635	737 mm	953 mm
1200 mm	R3636	949 mm	1165 mm



Experience our innovation

Rinnai.co.nz | **0800 746 624**

<http://www.youtube.com/rinnainz>

<http://www.facebook.com/rinnainz>