

Universal transponder reader

The LCN-ULT is a robust, universal transponder reader for passive transponders, to integrate in the LCN-Bus. The LCN-ULT can read out the most transponders built into car keys with electronic immobilizers, as well as many transponders and cards from access control systems, time recording systems and alarm systems, mechatronical lock cylinders and locks. Over LCN, allowance can be granted for example for, access permission for electrical locked doors or other building functions can be controlled. The LCN-ULT also reads out the LCN transponder cards LCN-ZTK, LCN-ZTS and LCN-AT2, Junghans watch with transponder, as well as the transponder systems EM (H4001, -4002, -4102, -4402, -4050, -4150, -4450), Megamos, ATMEL, Philips, Sokymat Nova, Texas Instruments, Temic and NXP.

Included in delivery

LCN-ULT, master card, -IV, -NU16 (power supply), Torx-Bit TX-10 & 2 pcs. screws (3,0 x 20 mm)

transponder reader LCN-ULT



Installation

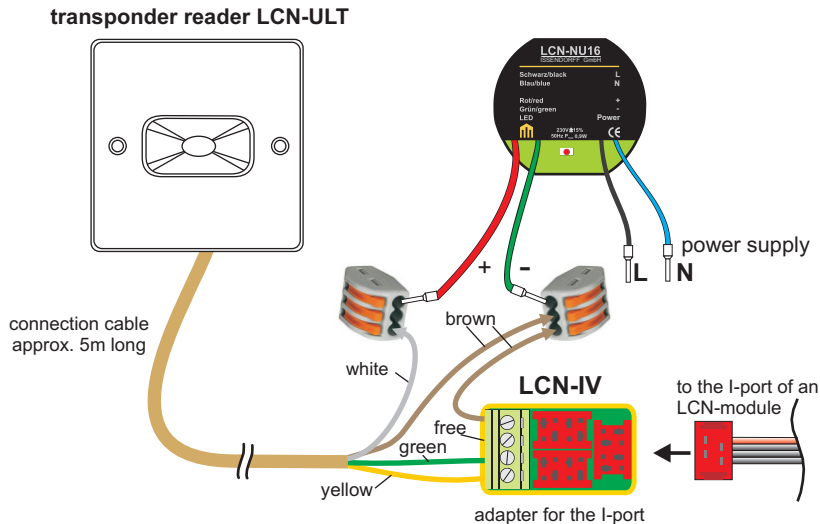

Installation

The transponder is supplied completely weatherproof with a 5 metre long shielded connecting cable. Because of this, it can be installed outdoors. The hole pitch corresponds to fixing standards (cavity wall box, outside switches, garage openers). The reader shows its readiness for operation with its permanently lit LED. This light can be adjusted with the command "LED control" (brighter/darker and red/blue).

Minimum distance between two LCN-ULT transponder readers to avoid them from interfering with each other, a possible distance of 75cm should be kept between each LCN-ULT.

Connection

The LCN-ULT is suitable for connecting to the I-port of all LCN modules with firmware 100A06 (Oct. 2006) or after. The LCN-ULT can be connected either directly to the I-port of an LCN module or extended up to a distance of 50m, by using additional LCN-IV's - see also installation guide LCN-IV.

Note: The operation with further I-port peripheries with bidirectional communication (e.g. LCN-GT4D, -GT10D or IOS-peripheries) is not permitted! **Operating the LCN-IV as pulse counter / counter input, is not possible!**

Attaching the reading head

Please make sure when tightening both of the screws with the supplied tool, that the tightening torque isn't too high. This applies especially when using an electrical screwdriver. Too much force can damage the plastic housing!

Usage in or on metal surfaces

The opening in the metal surfaces should be at least 60 mm, otherwise the metal could reduce the reception range drastically. In some cases the reading function can be completely distorted.

A damage to the system is not possible through this, the LCN-ULT recognises such influences and reduces the transmitting power automatically.

When a distinctive range reduction occurs, please try the function with the reading head away from its fixing point. Should the required reading range then be achieved, simply increase the distance to the surrounding metal surfaces.

Preparing for operation / learning new transponder types with an LCN-ULT

The ready to use reading head lights up blue permanently. When first delivered, the LCN-ULT will not recognise any transponders. When the master card is held shortly in front of the reader, the LED will flash slowly in blue. Remove the master card after this, the "learn mode"- is activated. Now the chosen transponder or car key is held in front of the reader, until the blue LED light stops flashing and lights up permanently again. Through this, the

communication parameter of this transponder type (transponder family), has been learnt in the LCN-ULT. After this, all transponders of the same type will be recognised and their ID numbers transferred to the I-port. The further distribution of authorizations or mappings from building functions for single ID numbers of different transponders, is done over the LCN Bus (transponder-codes) or in access control (LCN-GVSU).

If a master card is accidentally held too long (more than 5 sec.) in front of the card reader, it will flash red and change into the “erase” mode. Please remove the card straight away and wait until the transponder reader stops flashing and the blue LED lights up permanently again. Then go back into the “learn” mode again.

Preparing for operation / learning new transponder types with several LCN-ULT's

If there are there more than one LCN-ULT in the building, it is possible to transfer the new transponder types over the LCN Bus. In this case, all transponder readers will learn the new transponder types at the same time. To do this, hold the master card (as described above) for a short time in front of any one of the LCN-ULT's until the LED flashes slowly. Now hold the card in front of the LCN-ULT once more until the blue LED flashes up in a slow rhythm. If a card from one of the new transponder types is now held in front of the LCN-ULT, the LCN-ULT will transfer the transponder type over the I-port to the module. The module transfers this information to all modules within the LCN Bus. The LCN modules transfer the information over the I-port to the other LCN-ULT's, so they can also evaluate the new transponder types.

Note:

If a variety of similar transponder types are being used, only one representative LCN-ULT has to be learned. If for example, an EM H4102 and/or a HITAG 1 or HITAG S has to be learned, the transponder reader then transfers several ID numbers from this transponder type to the LCN Bus.

If a car key, transponder card or transponder keyring cannot be learned, you should check if a transponder is integrated. Most of the Mercedes models have no transponders in the key, they work with an immobilizer on an infrared base. The LCN-ULT cannot read out these keys.

Should a new generation of transponder chips be produced, that the LCN-ULT doesn't know today, the transponder reader can become a new firmware update, by loading a new software version.

Erasing single transponder types

Hold the master card in front of the transponder reader for longer than 5 seconds, until the red LED flashes slowly. Now remove the master card again. The mode „erase single transponder types“ is activated. Now hold the transponder card that has to be erased in front of the transponder reader, until the red LED stops flashing and the blue LED on the LCN-ULT lights permanently. This transponder type has now been erased from the type storage, the ID numbers of several members in this transponder family will not be

transferred to the I-port from now on.

Note:

Even if authorizations and function mappings for ID numbers are still being registered in the LCN module, all transponders of this erased type, will no longer be sent from the Transponder reader and not be transferred to the LCN Bus from this LCN-ULT.

Erasing all transponder types / condition on delivery

This function will erase the complete type storage and resets the LCN-ULT into the factory settings. The master card has to be held in front of the transponder reader for longer than 15 seconds. When the master card is recognised, the LED will flash in blue. After about 5 seconds it will flash slowly in red. After a further 10 seconds the slow flashing red will change to a fast flashing red. The fast flashing indicates that the transponder reader mode has changed to "preparing to ERASE ALL". Should the complete type storage not have to be erased, then please remove the master card and wait until the blue LED lights permanently again.

To carry out the removal of the complete type storage, the master card is held further until the LED switches off completely. The switching off of the LED is an indication, that whole type storage in the LCN-ULT has been erased (factory settings). After completion, the LED lights up again permanently.

For safety reasons, this function can only be carried out directly on each single LCN-ULT.

Transferring the command „ERASE ALL“ to other LCN-ULT´s in the LCN Bus, is not possible!

Building installation with several LCN-ULT´s (group formation, "commission")

When many LCN-ULT´s are being operated within one installation, the correct master card from each associated transponder reader must always be used for programming. To make this management more simpler, the following possibility has been created, to combine many LCN-ULT´s into a "group" or "commission".

This is possible with an order of over 5 LCN-ULT´s!

When ordering you must state, how many transponder readers and how many master cards that have to be combined. LCN-ULT´s will then be delivered, so that all the LCN-ULT´s can be programmed using the same master card. Even the amount of master cards is optional. Reordering for such a commission is possible at any time. No groups or commissions can be later formatted for LCN-ULT´s that have been already delivered.

LED blue/red

The colours of the Duo-LED´s can be toggled with a command and controlled in different brightnesses (for max. brightness, stronger power supply required). To do this, use the command "LED control/LCN-ULT" in the LCN-PRO version 3.5 or later.

Repairs

Due to safety reasons, transponder readers and master cards build a fixed associated unit from the manufacturer. When a master card is lost or a transponder reader is defect, then both parts have to be sent together for repairs or replacements.

Important: When a master card is lost, a replacement delivery is possible!

Unknown transponders / firmware updates

Should there be an unknown transponder or car key, that is not recognised from the LCN-ULT, please send it with details about its origin, with vehicles, details over the model and year of manufacture, for the LCN hotline to be able to analyse. In this way a firmware update can be produced and made available as soon as possible.

short overview over learning and erasing

Function	Action with master card	Feedback LED	Action with mit car key
<p>new key type (transponder type) learning with an LCN-ULT</p> <p>with several LCN-ULT's</p>	<p>hold the master card in front of the transponder reader (shorter than 5 seconds)</p> <p>hold the master card in front of the reader again</p>	<p>LED flashes slowly blue → mode „learning“ activated → lights blue permanently. as confirmation</p> <p>the blue LED flashes in a slow rhythm</p>	<p>hold the new transponder in front of the reader → the ID number will be sent to the LCN Bus when correctly identified</p>
<p>single car key types (transponder types) erasing</p>	<p>hold the master card for longer than 5 seconds</p>	<p>LED flashes slowly red → mode „single erasing“ activated → after erasing the LED lights up blue permanently straight away</p>	<p>hold the transponder to be erased in front of the reader → will be unlearned, erased from the storage</p>
<p>erasing all key types (erasing complete type storage → condition on delivery)</p>	<p>hold the master card for longer than 10 sec. → and then hold for a futher 5 sec. → until the LED goes off (confirmation for: "ALL ERASED")</p> <p>hold the master card in front of the reader again</p>	<p>LED flashes very fast red → mode „ALL ERASED“ is prepared (if „erase storage“ is not desired, remove the master card now!)</p> <p>When LED off → confirmation „type storage empty“</p>	<p>none</p>

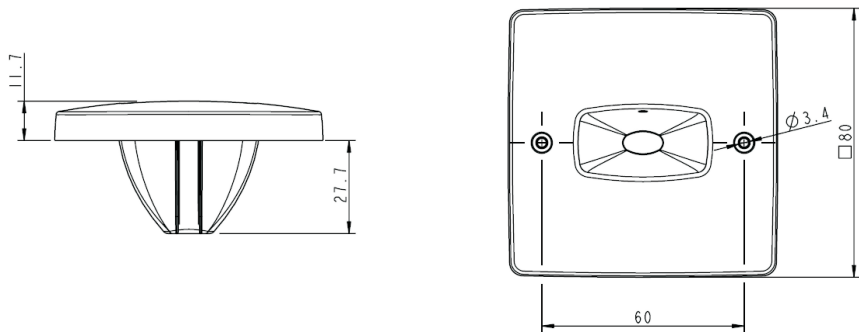
Dimensions of the reader

Technical data:**Connection**

power supply:	LCN-NU16 or power supply 6-11,5V DC (stable)
power consumption:	max. 110mA
LF low frequency-magnet field:	120kHz – 140kHz
application area:	outdoor- / indoor installation
LCN-connection:	connecting cable for connecting to an LCN-IV fine wire 4x 0,14mm ² wire ends tinned, length: approx. 5m
background light:	Duo-LED blue / red
reading distance:	typ. 0,2 – 7cm (depending on transponder type, - design, as well as installed location)
supported card systems:	LCN-ZTK; LCN-ZTS; LCN-AT2; EM H4001, -4002, -4102, -4402, -4050, -4150, -4450, Megamos, ATMEL, Philips, Sokymat Nova, TexasInstruments, Temic, NXP *The detailed descriptions of the card systems can be obtained from the technical hotline!

I

operating temperature:	-30°C to +70°C
protection art:	IP65
installation:	68mm flush mounted box
dimension (W x H):	80mm x 80mm
mounting height (D _A):	11,7mm
sinking depth (D _E):	27,7mm
colour / material:	white, optional silver / ASA (water and UV resistant)

Technical information and images are non binding. Changes are reserved.
Technical hotline: +49 5066 998844 or www.LCN.de