

The Trex logo is positioned in the upper left corner of the page. It features the word "Trex" in a bold, sans-serif font, with a registered trademark symbol (®) to its upper right. The logo is set against a semi-transparent, light-colored rectangular background. The overall image background is a close-up, shallow depth-of-field shot of wooden decking planks, showing the texture of the wood and the black plastic spacers used for installation.

Trex[®]

INSTALLATION GUIDE
TREX[®] DECKING
AND RAILING

Building your OUTDOOR HOME

DECKING

TRANSCEND



TREX TRANSCEND™

Outdecks all others

COMPOSITE



TREX BRASILIA®

Inspired by the rainforest



TREX ACCENTS®

Beautifully subtle



TREX CONTOURS®

Dramatically beautiful

PVC



TREX ESCAPES®

The richest PVC around

RAILING

TRANSCEND



TREX TRANSCEND RAILING

Perfect pairing of beauty and performance

COMPOSITE



TREX DESIGNER SERIES RAILING®

An elegant frame



TREX TRADITIONAL RAILING

Weather and kid-resistant

ADA



TREX® ADA HAND RAIL

Complementary and compliant

Trex® Installation Guide

In your hands, you're holding everything you need to begin building with Trex Decking & Railing. This guide will take you through all the steps you need to create a beautiful outdoor living space that fits perfectly into your or your client's lifestyle.

Only Trex has been proven in the field for almost twenty years of unparalleled performance. You'll find Trex offers a warm, natural beauty and an inviting comfort that no other product can match. Maybe that's why Trex is asked for by more customers than any other name in the business.





Table of Contents

- Trex Products 2
- Trex Specifications & Profiles 4-8
- Job Site Storage and Safety..... 9
- Tools 10
- Fasteners 11
- Trex Hideaway® Hidden Fasteners..... 12-15
- Framing and Fastening Tips..... 16
- Rooftop Decks and Sleeper Systems 17
- Code Compliance 18
- Gapping 19
- Stairway Assembly 20
- Bending Tips 21-22
- Trex Traditional Anchored Railing 23-24
- Trex Traditional Raised Railing..... 25-32
- Trex Designer Series Railing® 33-36
- Trex Transcend™ Railing..... 37-52
- Trex ADA Hand Rail..... 53-56
- Transcend Care and Cleaning Guide 57
- Composite & PVC Care and Cleaning Guide..... 58
- Mold Technical Bulletin 59
- Limited Residential Warranty..... 60
- Limited Commercial Warranty..... 61
- Transcend Limited Residential Fade & Stain Warranty 62-63
- Transcend Limited Commercial Fade & Stain Warranty ... 64-65
- Physical and Mechanical Properties 66

From time to time, Trex revises its installation instructions. To ensure you have the most up to date installation instructions, please visit trex.com.

FEET CONVERTED TO METERS
 INCHES CONVERTED TO CENTIMETERS
 *Except where noted.



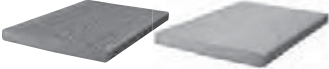

Specifications & Profiles

DECKING	DESCRIPTION	ITEM NUMBER	COLORS	
1" Square Edge Board Actual Dimensions: 1" x 5.5" 	1 x 6 x 12' Transcend	XX010612TS48	TH, VL, GP, FP	
	1 x 6 x 16' Transcend	XX010616TS48		
	1 x 6 x 20' Transcend	XX010620TS48		
	1 x 6 x 12' Brasilia (Special Order)	XX010612BS48	AM, CY, ES	
	1 x 6 x 16' Brasilia	XX010616BS48		
	1 x 6 x 20' Brasilia (Special Order)	XX010620BS48		
	1 x 6 x 12' Accents	XX010612AS48	WG, WB, MB, SD	
	1 x 6 x 16' Accents	XX010616AS48		
	1 x 6 x 20' Accents	XX010620AS48		
	1 x 6 x 12' Contours (Special Order)	XX010612CS48	WG, MB, SD <small>(MB available via Special Order)</small>	
	1 x 6 x 16' Contours	XX010616CS48		
	1 x 6 x 20' Contours (Special Order)	XX010620CS48		
	1 x 6 x 16' Escapes		AC, PW	
	1 x 6 x 20' Escapes			
1 x 6 x 16' Fire Defense	XX010616FS48	WG, SD		
1 x 6 x 20' Fire Defense	XX010620FS48			
2" Square Edge Board Actual Dimensions: 2x4: 1.5"x 3.5" 2x6: 1.5"x 5.5" 	2 x 4 x 12' Smooth	XX020412BS120	AM, CY	
	2 x 4 x 16' Smooth	XX020416BS120		
	2 x 4 x 12' Smooth	XX020412OS120	WG, WB, MB, SD	
	2 x 4 x 16' Smooth	XX020416OS120		
	2 x 6 x 12' Accents	XX020612AS72		
	2 x 6 x 16' Accents	XX020616AS72		
	2 x 6 x 20' Accents	XX020620AS72		
	2 x 6 x 20' Fire Defense	XX020620FS72		
1" Grooved Edge Board Actual Dimensions: 1" x 5.5" 	1 x 6 x 12' Transcend	XX010612TG48	TH, VL, GP, FP	
	1 x 6 x 16' Transcend	XX010616TG48		
	1 x 6 x 20' Transcend	XX010620TG48		
	1 x 6 x 12' Brasilia	XX010612BG48	AM, CY, ES	
	1 x 6 x 16' Brasilia	XX010616BG48		
	1 x 6 x 20' Brasilia	XX010620BG48		
	1 x 6 x 12' Accents	XX010612AG48	WG, WB, MB, SD	
	1 x 6 x 16' Accents	XX010616AG48		
	1 x 6 x 20' Accents	XX010620AG48		
	1 x 6 x 12' Contours	XX010612CG48	WG, SD, MB* <small>*available via Special Order</small>	
	1 x 6 x 16' Contours	XX010616CG48		
	1 x 6 x 20' Contours	XX010620CG48		
	1" x 8' Fascia Actual Dimensions: .75" x 7.25" x 12" 	1 x 8 x 12' Transcend	XX010812TS60	TH, VL, GP, FP WG, WB, MB, SD
		1 x 8 x 12' Smooth	XX010812OS60	
1" x 12' Fascia Actual Dimensions: .75" x 11.375" x 12" 	1 x 12 x 12' Transcend	XX011212TS40	TH, VL, GP, FP AM, CY, ES WG, WB, MB, SD AC, PW	
	1 x 12 x 12' Brasilia	XX011212BS40		
	1 x 12 x 12' Smooth	XX011212OS40		
	1 x 12 x 12' Escapes			

XX = COLOR PREFIX:
 VL Vintage Lantern GP Gravel Path ES Espresso AM Burnished Amber SD Saddle MB Madeira AC Acorn
 TH Tree House FP Fire Pit CY Cayenne WB Woodland Brown WG Winchester Grey PW Pewter

TREX HIDEAWAY® HIDDEN FASTENER SYSTEM	DESCRIPTION	ITEM NUMBER
Connector Clip (stainless steel)	50 sq. ft. box	CLIPCONNECT
Start/Stop Clip (stainless steel)	500 sq. ft. bucket	CLIPBUCKET
Universal Fastener (plastic)	400 sq. ft. bag	CLIPSTART
	50 sq. ft. box	DA00001
	500 sq. ft. bucket	DA00002
Router Bit	Router Bit	ROUTERBIT

Trex Transcend™ Railing Specifications & Profiles

	STEPS	DESCRIPTION	ITEM NUMBER
STEP 1	<p>Post Sleeve</p> 	<p>4 x 4 39" Post Sleeve 4 x 4 96" Post Sleeve 6 x 6 39" Post Sleeve 6 x 6 96" Post Sleeve</p> <p><i>(Each 4x4 Post Sleeve includes a corrugated TrexExpress Railing Assembly Tool)</i></p>	<p>XX040439APS XX040496APS WT060639APS WT060696APS</p> <p><i>(Each 4x4 Post Sleeve includes a corrugated TrexExpress Railing Assembly Tool)</i></p>
STEP 2	<p>Post Sleeve Skirt</p> 	<p>4 x 4 Post Sleeve Skirt 6 x 6 Post Sleeve Skirt</p>	<p>XXSKIRT4X4 WTSKIRT6X6</p>
STEP 3	<p>Railings</p> 	<p>6' Top & Bottom Rail Kit 8' Top & Bottom Rail Kit 6' Top & Bottom Stair Rail Kit 8' Top & Bottom Stair Rail Kit 6' Universal Rail Kit 8' Universal Rail Kit 6' Universal Stair Rail Kit 8' Universal Stair Rail Kit 6' x 36" Complete Rail Kit—Horizontal 6' x 42" Complete Rail Kit—Horizontal 6' x 36" Complete Rail Kit—Stair 6' x 42" Complete Rail Kit—Stair 8' x 36" Complete Rail Kit—Horizontal 8' x 42" Complete Rail Kit—Horizontal 8' x 36" Complete Rail Kit—Stair 8' x 42" Complete Rail Kit—Stair 6' x 36" Glass Panel Rail Kit 91.5" Railing Top Cap*</p> <p><i>*(Railing Top Cap available in Charcoal Black, Acorn, Madeira, Winchester Grey and Woodland Brown)</i></p>	<p>XX06HRK XX08HRK XX06SRK XX08SRK XX06HURK XX08HURK XX06SURK XX08SURK WT0636HRK WT0642HRK WT0636SRK WT0642SRK WT0836HRK WT0842HRK WT0836SRK WT0842SRK WT0636HPK XXTOPCAP*</p>
STEP 4	<p>Balusters/Spindles</p> 	<p>30" Square Baluster Kit (16 per kit) 36" Square Baluster Kit (16 per kit) 36" Colonial Spindle Kit (16 per kit) 30 x 1 Architectural Baluster (5 per kit) 32 x 1 Architectural Baluster (5 per kit) 36 x 1 Architectural Baluster (5 per kit) 40 x 1 Architectural Baluster (5 per kit) Architectural Baluster Spacer—Level Architectural Baluster Spacer—Stairs 26 x 3/4 Round Baluster Kit (10 per kit) 30 x 3/4 Round Baluster Kit (10 per kit) 32 x 3/4 Round Baluster Kit (10 per kit) 36 x 3/4 Round Baluster Kit (10 per kit) Round Hole Contemporary Baluster Spacer—Level Round Hole Contemporary Baluster Spacer—Stairs</p>	<p>XX020230SBK XX020236SBK WT020236CSP BK0130VBK BK0132VBK BK0136VBK BK0140VBK XXHVASPCR XXSVASPCR BK3Q26RBK BK3Q30RBK BK3Q32RBK BK3Q36RBK XXBALSPACER XXBALSPACESTR</p>
STEP 5	<p>Post Sleeve Cap</p> 	<p>Flat 4 x 4 Post Sleeve Cap Pyramid 4 x 4 Post Sleeve Cap Flat 6 x 6 Post Sleeve Cap Pyramid 6 x 6 Post Sleeve Cap</p>	<p>XXSQCAP4X4 XXPYCAP4X4 WTSQCAP6X6 WTPYCAP6X6</p>

Trex Transcend™ Railing System

TOP & BOTTOM RAIL KIT

- » Standard Top Rail
- » Standard Bottom Rail
- » Adjustable Foot Block
- » Square Hole Baluster Spacers
- » Mounting Hardware

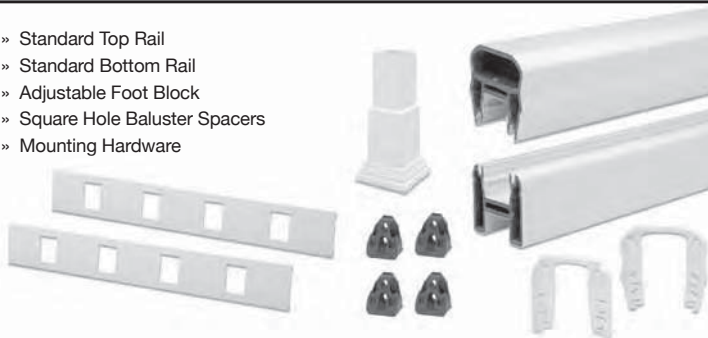

item number
 XX06HRK
 XX08HRK
 XX06SRK
 XX08SRK

description
 6' Top & Bottom Rail Kit
 8' Top & Bottom Rail Kit
 6' Top & Bottom Stair Rail Kit
 8' Top & Bottom Stair Rail Kit

UNIVERSAL TOP & BOTTOM RAIL KIT

- » 2 Standard Bottom Rails
- » Adjustable Foot Block
- » Square Hole Baluster Spacers
- » Mounting Hardware

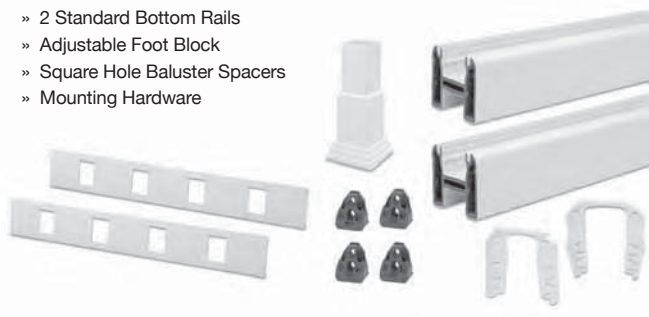

item number
 XX06HURK
 XX08HURK
 XX06SURK
 XX08SURK

description
 6' Universal Rail Kit
 8' Universal Rail Kit
 6' Universal Stair Rail Kit
 8' Universal Stair Rail Kit

GLASS PANEL KIT

- » Standard Top Rail
- » Standard Bottom Rail
- » Mounting Hardware
- » 4 Panel Support Mouldings
- » 2 Pcs. Weatherstrip
- » 4 - 8" Baluster Spacers



item number
 WT0636HPK

description
 6' x 36" Glass Panel Rail Kit

COMPLETE TOP & BOTTOM RAIL KIT

- » Standard Top Rail
- » Standard Bottom Rail
- » Baluster for Foot Block
- » Square Hole Baluster Spacers
- » Balusters
- » Mounting Hardware

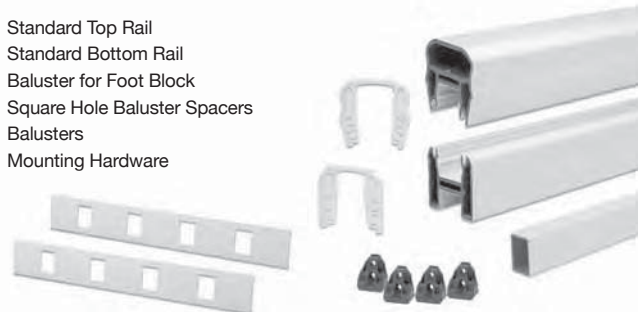

item number
 WT0636HRK
 WT0642HRK
 WT0636SRK
 WT0642SRK
 WT0836HRK
 WT0842HRK
 WT0836SRK
 WT0842SRK

description
 6' x 36" Complete Rail Kit—Horizontal
 6' x 42" Complete Rail Kit—Horizontal
 6' x 36" Complete Rail Kit—Stair
 6' x 42" Complete Rail Kit—Stair
 8' x 36" Complete Rail Kit—Horizontal
 8' x 42" Complete Rail Kit—Horizontal
 8' x 36" Complete Rail Kit—Stair
 8' x 42" Complete Rail Kit—Stair

TRANSCEND SYSTEM COMPONENT PARTS

DESCRIPTION

- 0 Degree Railing Cut Kit
- 45 Degree Gasket & RSB Adaptor Kit
- Stair Railing Cut Kit
- 0 Degree Rail Connection Gaskets
- 22.5 Degree Rail Connection Gaskets
- 45 Degree Rail Connection Gaskets
- Stair Rail Connection Gaskets





ITEM NUMBER

- XXHCUT
- XX45RSBADAP
- XXSCUT
- XX00HGAS
- XX22HGAS
- WT45HGAS
- XX00SGAS

XX= INSERT COLOR PREFIX

- WT— Classic White
- BK— Charcoal Black
- FP— Fire Pit
- TH— Tree House
- GP— Gravel Path
- VL— Vintage Lantern

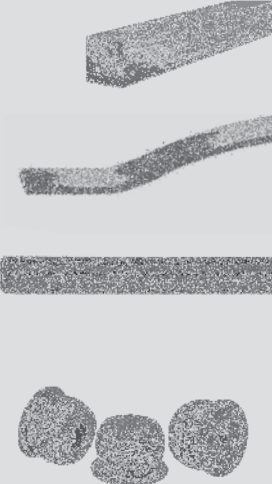
Designer/Traditional Railing Specifications & Profiles

STEPS		DESCRIPTION	ITEM NUMBER
STEP 1	Posts 	4 x 4 48" Post Sleeve 4 x 4 108" Post Sleeve 4 x 4 52" Railpost	XX040448PS XX0404108PS XX040452 <i>(TrexExpress™ template available for quick & accurate assembly)</i>
		4 x 4 Post Sleeve Skirt 4 x 4 Railpost Skirt	XXRPSSKIRT XXSKIRT
STEP 2	Railpost Skirt/ Post Sleeve Skirt 		
STEP 3	Railings 	6' Top & Bottom Rail Kit* * (Includes standard top & bottom rails, baluster for foot block & mounting hardware) The 1" boards and 2x4 boards needed to accomplish the Traditional railing configuration are listed under Decking	XX06HRK (Level & Stair sections available)
STEP 4	Balusters/Spindles 	30" Square Baluster Kit (16 per kit) 36" Square Baluster Kit (16 per kit) 144" Bulk Balusters 30x1 Architectural Baluster Kit (5 per kit) 32x1 Architectural Baluster Kit (5 per kit) 36x1 Architectural Baluster Kit (5 per kit) 40x1 Architectural Baluster Kit (5 per kit) 26x3/4 Round Baluster Kit (10 per kit) 30x3/4 Round Baluster Kit (10 per kit) 32x3/4 Round Baluster Kit (10 per kit) 36x3/4 Round Baluster Kit (10 per kit) 3/4" Round Baluster Connector 3/4" Stair Round Baluster Connector	XX020230SBK XX020236SBK XX2X2X144B BK0130VBK BK0132VBK BK0136VBK BK0140VBK (All of these are only to be purchased when constructing a Transcend or Traditional railing) BK3Q26RBK BK3Q30RBK BK3Q32RBK BK3Q36RBK BK075HCON BK075SCON
STEP 5	Railpost Cap/ Post Sleeve Cap 	Flat Post Cap Pyramid Post Cap Flat Post Sleeve Cap Pyramid Post Sleeve Cap	XXSQCAP XXPYCAP XXRPSSQCAP XXRPSPYCAP

XX= INSERT COLOR PREFIX

AM— Burnished Amber
 CY— Cayenne

MB— Madeira
 SD— Saddle

WB— Woodland Brown
 WG— Winchester Grey

DESIGNER RAILING SYSTEM		DESIGNER SYSTEM COMPONENT PARTS	
TOP & BOTTOM RAIL KIT		DESCRIPTION	ITEM NUMBER
includes: » Standard Top Rail » Standard Bottom Rail » Baluster for Foot Block » Mounting Hardware	item number XX06HRK description 6' Top & Bottom Rail Kit (Level & Stair sections available)	Designer Railing Cut Kit 72" Top Hand Rail Replacement Kit Designer Railing Post TrexExpress Tool Designer Railing Sleeve TrexExpress Tool	DSRAILKIT XX06THRPL RAILTOOL PSTOOL

ADA Railing Specifications & Profiles

DESCRIPTION & ITEM NUMBER

1 104" Straight Rail, 1.5" diameter
(PVC with Aluminum Stiffener)
BLACK: BKADARAIL
SADDLE: SDADARAIL
WHITE: WTADARAIL



2 Wall Return w/Cover Plate
(PVC with Aluminum Stiffener)
BLACK: BKADA90WRK
SADDLE: SDADA90WRK
WHITE: WTADA90WRK



3 Straight Wall Return
(Cast Iron)
BLACK: BKADASWRK
SADDLE: SDADASWRK
WHITE: WTADASWRK



4 Handrail Bracket w/Screws & Cap
(Cast Iron)
BLACK: BKADARBK
SADDLE: SDADARBK
WHITE: WTADARBK



5 90 Degree Corner
(PVC)
BLACK: BK90CORN
SADDLE: SD90CORN
WHITE: WT90CORN



6 End Loop
(PVC with Aluminum Stiffener)
BLACK: BKADALOOP
SADDLE: SDADALOOP
WHITE: WTADALOOP



7 Post Return ("Candy Cane")
(PVC with Aluminum Stiffener)
BLACK: BKADARET
SADDLE: SDADARET
WHITE: WTADARET



8 Straight Joiner
ALUMINUM: ALSTJOIN

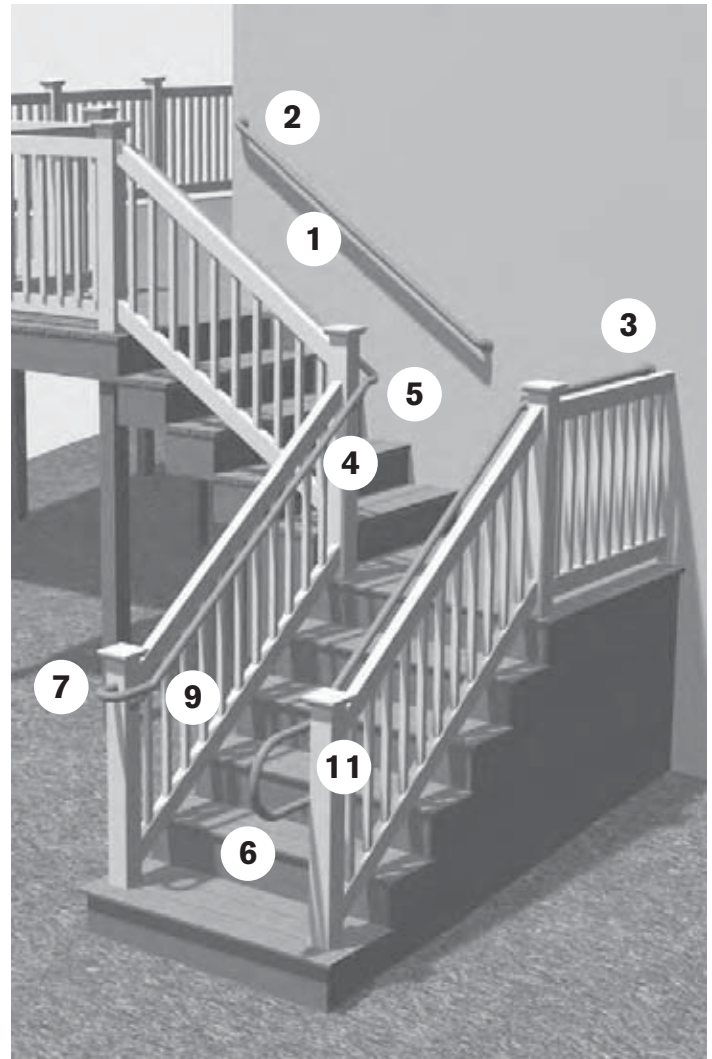

DESCRIPTION & ITEM NUMBER

9 Adjustable Joiner
ALUMINUM: ALADJOIN



10 Joint Ring
(Plastic)
BLACK: BKADARING
SADDLE: SDADARING
WHITE: WTADARING



11 Rail End Cap
(Plastic)
BLACK: BKADACAP
SADDLE: SDADACAP
WHITE: WTADACAP



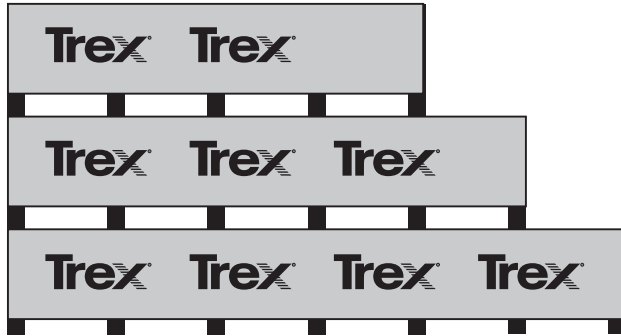

Units of Trex lumber on level ground.

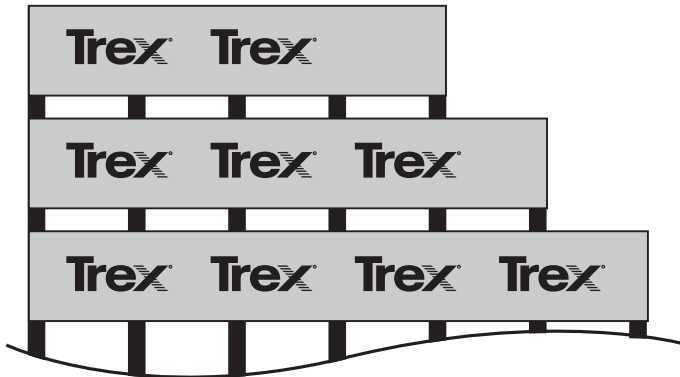

Units of Trex lumber on uneven ground.

Job Site Storage

There are several important things to remember when storing Trex® decking, railing and fencing. Trex decking, railing, fencing and trim. All Trex outdoor living products must be stored on a flat surface.

- Trex products must be supported with dunnage as placed in bundles.
- When stacking Trex products, supports should start at each end of the unit and line up vertically.
- Trex products must be supported on a level plane. Adjust support blocks accordingly.
- Do not stack Trex higher than 6 units or 12' (3.7 m) high.
- **Cover material on site until it is to be installed.**

Safety

As with any construction project, you should wear the proper protective clothing and safety equipment. Trex decking and railing is heavier and more flexible than wood. Do not try to lift similar quantities of Trex boards as you would traditional lumber. It is good practice to wear safety glasses, gloves, a dust mask and long sleeves, particularly when cutting in confined spaces.

Tools

Intricate shapes, profiles and patterns are possible with Trex®. For most installments, no special tools are required. For best results, use carbide-tipped blades and router bits.

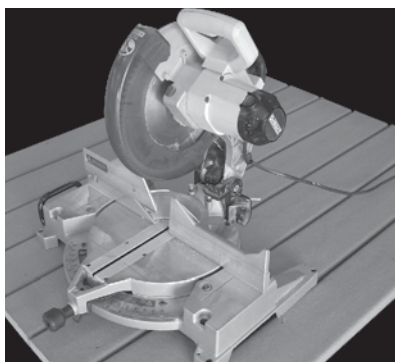

When using a miter saw, we recommend a 10 - 12" (25.4 - 30.5 cm) saw blade with 40 teeth or less. When cutting Trex Transcend™ Railing or Trex Escapes®, we recommend using a 60-tooth carbide-tipped blade.



Install Trex recommended fasteners with standard power drills.



Screw guns provide a quick and easy way to fasten Trex.



When drilling, periodically lift the bit out of the hole to remove the shavings.

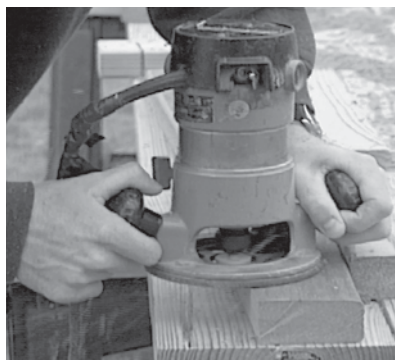

Trex routs beautifully to give extremely crisp edges. Do not rout balusters, 4 x 4 Trex Railpost™, Trex Escapes®, or Trex Transcend™ profiles. Routing will change the surface of Trex products.

FACT:

- Most colored chalk lines are permanent. **We suggest using baby powder or Irwin strait-line dust off marking chalk available at irwin.com.**
- We do not recommend sanding. Sanding will change the appearance of the surface of the Trex material, **and can void warranty.**

Fasteners

Trex® decking can be assembled with most traditional fastening methods. It is recommended to install all fasteners perpendicular (at a 90 degree angle) to the boards. If screws are not installed at a 90 degree angle, then “dimpling” near the fastener head may result and leave a less than satisfactory appearance.

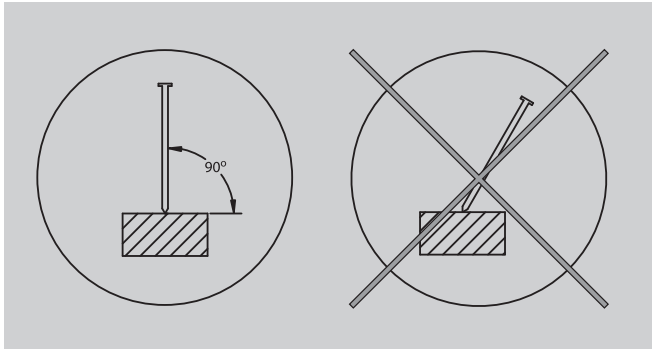

For best results, we recommend the following fasteners, which work well and provide an attractive appearance:

Accents, Accents Fire Defense, Brasilia & Contours Screws

- Dexxter Composite Screw
swansecure.com; 800-966-2801
- FastenMaster® TrapEase® II Composite Screw
fastenmaster.com; 800-518-3569
- Phillips II Plus High Performance/Pozisquare Composite Decking Screw
phillipsii.com; 888-332-6283
- Quik Drive Composi-Lok deck screws by Simpson Strong-Tie. strongtie.com; 800-999-5099
- Universal Fastener Outsourcing, LLC
911-Nails.com; 800-352-0028 or 479-443-9292

No pre-drilling is required when using the above screws in Trex material, with the exception of Toe Screwing (see Framing and Fastening Tips).

Transcend™

FastenMaster® TrapEase® II Composite Screw:

- fastenmaster.com / 1-800-518-3569

Phillips II Composite Decking Screw:

- phillipsii.com / 1-888-332-6283

DO NOT ROUT TRANSCEND.

Hidden Fasteners

- Trex Hideaway® trex.com

Dexxter Composite Screw is a trademark of Swan Secure Products, Inc.

FastenMaster TrapEase® II and IQ Hidden Fastening System® are registered trademarks of OMG, Inc.

Tiger Claw® TC-3 Composite Fastener is a registered trademark of Tiger Claw®

NailScrews® is a registered trademark of Universal Fastener Outsourcing

Scrudini™ is a trademark of Swan Secure Products, Inc.

Hidden Link™ is a trademark of Pan American Screw/Sure Drive USA.

MINIMUM FASTENER SIZE

Profile	Nails		Screws	
	Length	Gauge	Length	No.
5/4 x 6	2 1/2" (6.4 cm)	12	2-1/2" (6.4 cm)	#8, #10
2 x 6	3" (7.6 cm)	12	3" (7.6 cm)	#8, #10

Escapes®

Color-matched Screws:

- Scrudini™ hand-drive screws
swansecure.com; 800-966-2801
- FastenMaster® TrimTop™ Stainless Screws
fastenmaster.com; 800-518-3569

Hidden Fasteners:

- Cortex by Fastenmaster
- Hidden Link hidden deck fastening system
www.suredrive.com / 1-800-951-2222

DO NOT USE HIDEAWAY HIDDEN FASTENERS WITH ESCAPES.

Note: when using Pneumatic or battery-operated nailers, it is important to adjust the pressure to only shoot the head of the nail to be flush with the board's cap. The nail head should not be shot completely through the cap.

Fastening Tips for Trex Escapes®

Trex Escapes can be fastened, with the above fasteners, at least 1/2" (1.25 cm) and not more than 4" (10.2 cm) from the board edge without splitting. No pre-drilling is required with Trex Escapes. **DO NOT ROUT ESCAPES.**

Trex Hideaway® Stainless Steel Hidden Fasteners

Maximum spacing of deck boards for use with Hideaway system is 16" (40.6 cm) on center.

STEP 1 — Starting the First Board

Install screw straight down through start/stop clip and into ledger board. Screw should be in line with center of each joist. It is important that this board is straight and well secured. *See Illustration A*

STEP 2 — Position Fasteners

Full insert connector clip into grooved edge of deck board. Screw hole should be in line with center of joist. *See Illustration B*

STEP 3 — Install First Fastener

While standing on deck board, install provided screw at a 45° angle through fastener and into joist, while applying pressure on fastener. Install one fastener and screw at each support joist. *See Illustration D*

Make sure fastener body is vertical to deck board and the screw is holding fastener down tight to deck board.

STEP 4 — Completing Installation of Boards

- Place next deck board into position. Holding the deck board 2" back from fastener, push deck board with enough force to lock into place.
- Check gap between boards for consistency. Apply force to ensure board is fully installed engaging boards with 1/4" bump-stop tab.

Trex Hideaway® fasteners will provide proper 1/4" (0.6 cm) gapping when installed correctly. *See Illustration E*

STEP 5A — Installing the Last Board using Fascia Board (Option 1)

To finish, install start/stop clip and install screw at a 45° angle through clip tab and into joist. Install a vertical fascia board flush with deck board surface. *See Illustration C*

STEP 5B — Installing the Last Board using with Overhang (Option 2)

Prior to installing last board, predrill a pilot hole at a 45° angle through rim joist. Once hole is drilled, put last board in place and install a 2 1/2" (6.4 cm) decking screw into predrilled pilot hole. *See Illustration F*

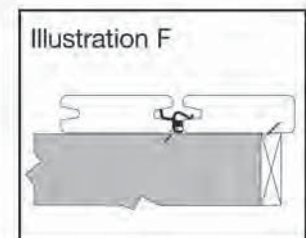
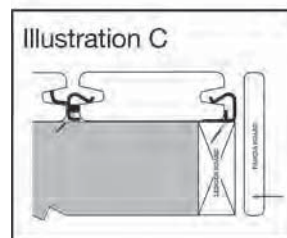
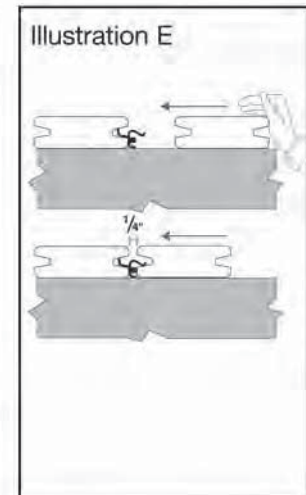
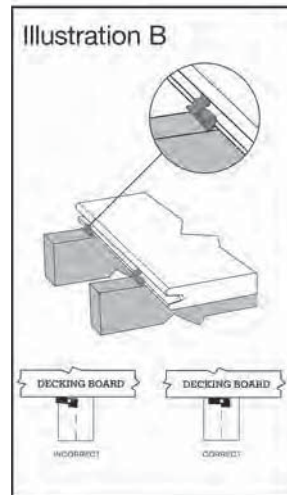
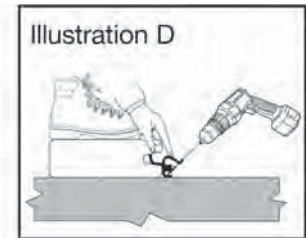
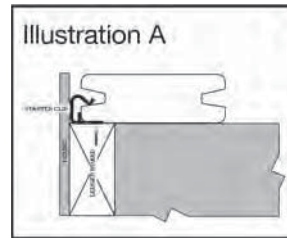

Trex Hideaway® Universal Hidden Fasteners

Maximum spacing of deck boards for use with Hideaway system is 16" (40.6 cm) on center.

STEP 1 — Installing the Start/Stop Clips

Install screw straight down through start/stop clip and into ledger board. Screw should be in line with center of each joist. Stop should be placed at edge of ledger board.

See *Illustration A*

STEP 2 — Install First Board

Install the first board by pushing the board into the Hideaway start/stop clip. It is important that this board is straight and well secured. See *Illustration B*

STEP 3 — Install Connector Clips

Install the first Hideaway connector clip by holding the tab into the groove and screwing the screw into the joist half way. Do not fully tighten the screw. Screw hole should be in line with the center of joist.

Continue this installation along the length of the board at every joist.

See *Illustration C*

STEP 4 — Installing Second Board

Slide the second deck board into place, ensuring that the connector clips fit into the groove.

Install the next Hideaway connector clip on the other side of the second board in the same manner as Step 3. Do not fully tighten the screw. Continue along the length of the board at every joist.

Trex Hideaway® fasteners will provide proper 1/4" (0.6 cm) gapping when installed correctly. See *Illustration D*

STEP 5 — Completing Installation of Boards

Tighten the screws on the Hideaway connector clips in the first row. Be sure to use the long #1 square bit provided. See *Illustration E*

Continue to the end of the deck and use Trex Hideaway™ start/stop clips or face screws on the last board.

STEP 6A — Installing the Last Board using Fascia Board (Option 1)

To finish, install start/stop clip and install screw at a 45° angle through clip tab and into joist. Install a vertical fascia board flush with deck board surface. See *Illustration F*

STEP 6B — Installing the Last Board using with Overhang (Option 2)

Prior to installing last board, predrill a pilot hole at a 45° angle through rim joist. Once hole is drilled, put last board in place and install a 2 1/2" (6.4 cm) decking screw into predrilled pilot hole. See *Illustration G*

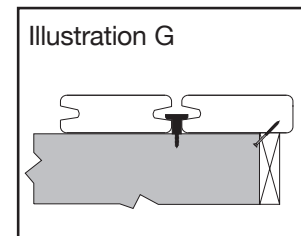
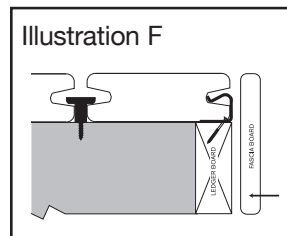
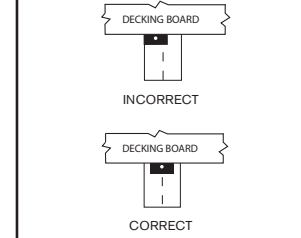
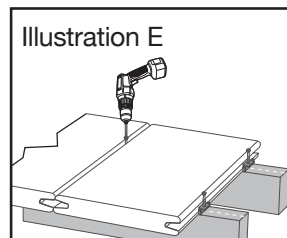
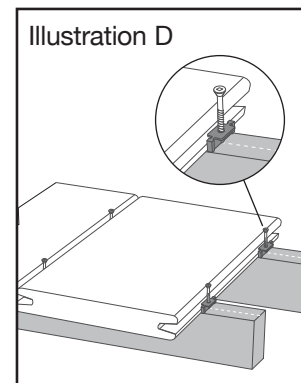
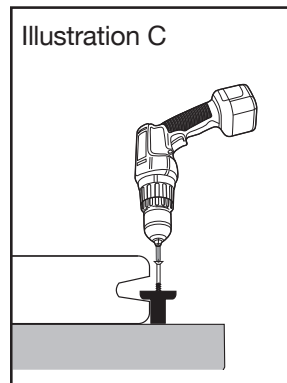
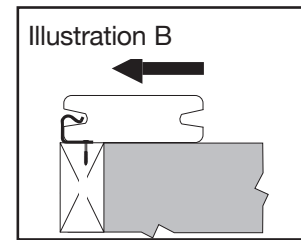
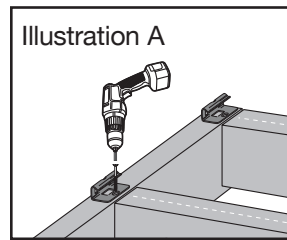

Trex Hideaway® Hidden Fasteners: Stainless Steel & Universal

What tools are required?

No special tools are required when using pre-grooved deck boards, just a drill with screwdriver tip. When using decking without the grooved edge, a router with proper bit will be needed to create a groove in board edge at each joist or along the entire edge of the deck board.

45° angle installation

Where deck is in the walled corner of the house: Always start with small triangular piece of decking in that corner and work your way out. When installing Trex Hideaway® fasteners, offset the center 1/2" (1.3 cm) towards the long point of joist so screw will not exit side of joist when driven.

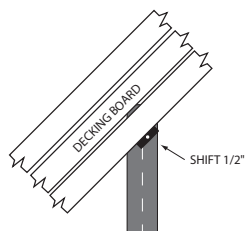

For Universal & Stainless Steel (universal shown here)

How to install a butt seam

First, install a small framing board (10 – 12"/25.4 - 30.5 cm) alongside the joist in which the seam is going to land. Install additional fastener into previous board above small framing block. Line up your first board in the center of the joist and the small framing board. Install fasteners and screws at each joist of the first board including the joist at the seam. Then install your second board in the same fashion, and place a second fastener at the seam attaching it to the small framing block. Make sure you follow end-to-end gapping specifications.

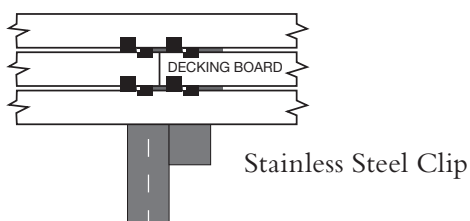
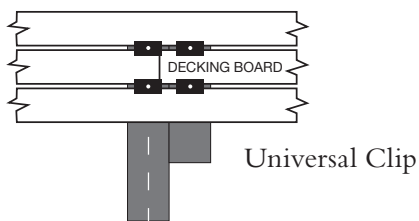

To use the Trex Hideaway Fasteners on unslotted boards:

Use the Trex Router Bit, available at your local Trex dealer.

- a When using the Trex Router Bit, flip board over and route from the bottom side.
- b Use the Trex Router Bit routing bit to create a groove at every intersection of the deck board and support joists, as well as entire edge of the board.

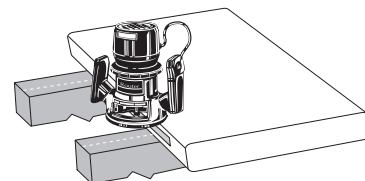

NOTE: DO NOT ROUT TREX TRANSCEND OR TREX ESCAPES.

How to replace a board when using Stainless Steel clips

- a Make two parallel cuts down the center of the board to be replaced, and remove the center piece.
- b Using a small pry bar, remove the remaining pieces of decking from the tabs.
- c Hammer down the tabs on the sides of the board with the screw head shown on one side of the opening only.
- d Position new board into place, and carefully position onto remaining tabs.
- e Once board is set into position, secure the lead edge with finish nail, finish screw, or using counter drill, screw and plug.

How to replace a board when using Universal clips

Board Removal

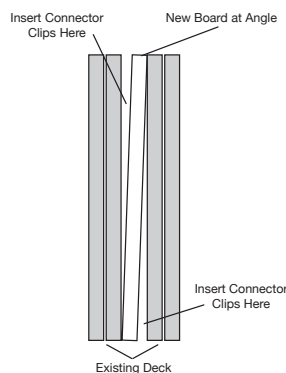

1. Remove fasteners on either side of board.
 2. Remove board.
 3. Insert new board into place and angle.
 4. Insert all Hideaway connector clips required into either side of board. (see illustration below)
- Note: It may require loosening of adjacent boards to allow for fastener replacement.
5. Straighten board on deck structure and fasten Hideaway connector clip at each joist.

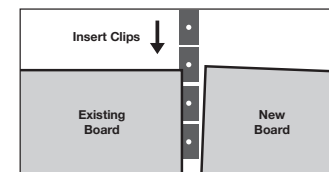

Trex Hideaway® Hidden Fasteners: Stainless Steel & Universal

How to install stairs

Option 1

- Install start/stop clip against riser.
- Install first board and connector clip.
- Install second board.
- Install face screw from the top of the second board into the riser.

Option 2

- Install start/stop clip against riser.
- Install first board and connector clip.
- Fasten 2x4 block to stringers.
- Pre-drill hole through 2x4 upward at an angle for face screw.
- Install second board.
- Install screw from below through 2x4 into bottom of tread.

Connector Clip

- Multiply the number of joists by the number of decking boards to equal the number of fasteners needed.
- 90 fasteners will cover approximately 50 sq. ft. (103 cm²) (using 5.5" (14 cm) decking boards on 16" (40.6 cm) centers).

Start/Stop Clip Fasteners Needed

0.75 Clips needed for ever 1 lineal foot of decking. If clips will be used for last board, double the amount calculated above.

CONNECTOR CLIP FASTENERS NEEDED

Joist Spacing (on center)	Deck Size sq. ft.				
	100	200	300	400	500
12" (30.5 cm)	210	441	672	882	1113
16" (40.6 cm)	175	336	512	672	848

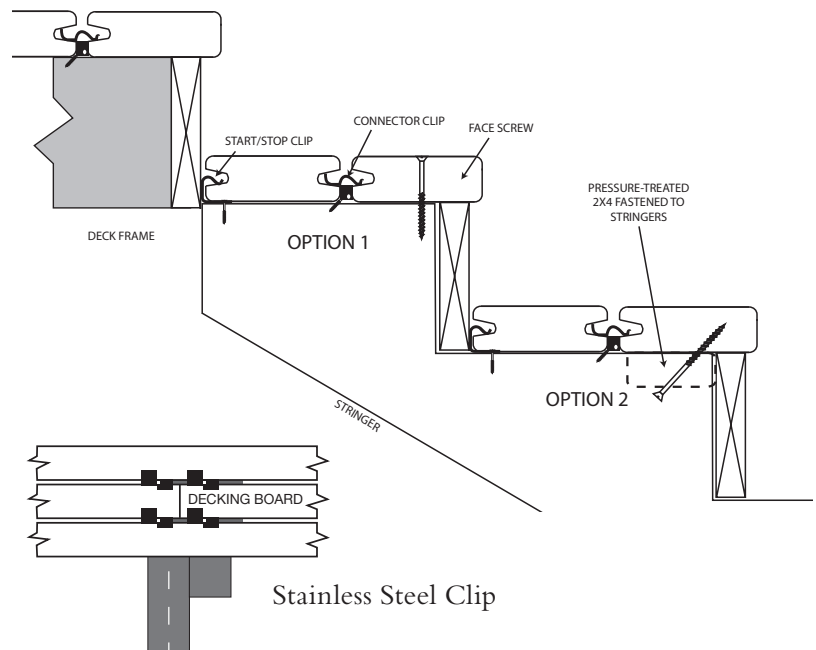
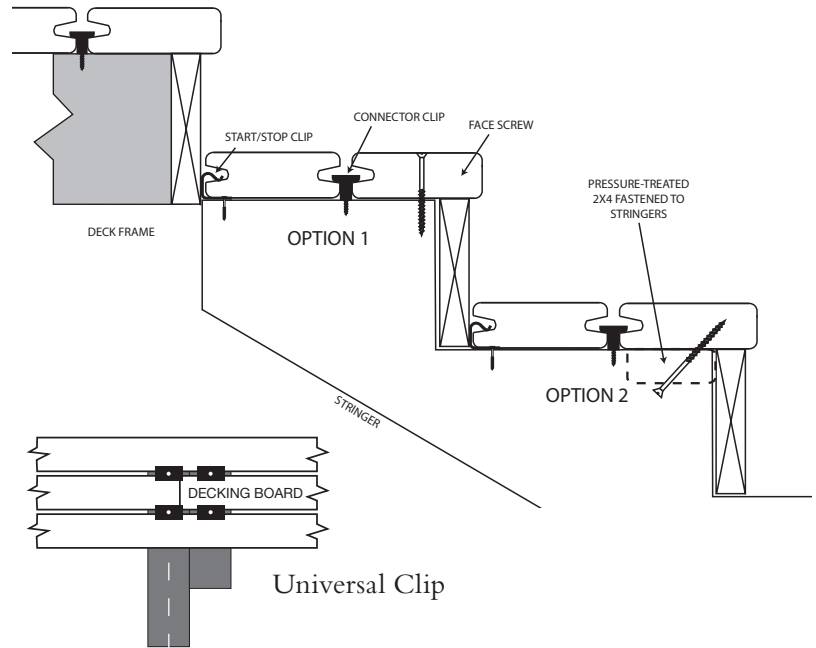

Framing and Fastening Tips

Check your local building codes for restrictions. Trex® cannot be used for structural applications. Do not attach Trex decking directly to any solid surface or watertight system. See sleeper systems on page 13.

Fastening Tips

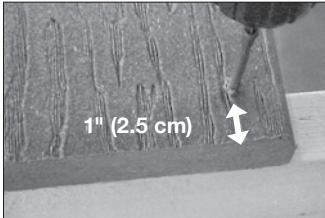

At board ends on the deck's edge, screws placed perpendicular at the recommended distance - at least 1" (2.5 cm) and not more than 4" (10.2 cm) from the board edge and side can be installed without board spitting.

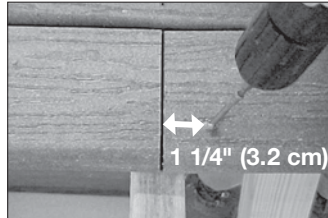

Trex does not have a linear grain like wood, and will not split if fasteners are started 1 1/4" (3.2 cm) from the board edges and angled into the joist. 1" (2.5 cm) can be done, but should be pre-drilled first. Pre-drilling will reduce the probability of splitting. Please see page 15 for gapping guidelines.



An alternative method for butt joints, where boards meet over a single joist, is to add a 2 x 4 "nailer" board at the butt joint. This allows a screw to be installed at a 90 degree angle.

Note: Fasten board ends with at least two fasteners. Fasten at least one fastener at every joist in a zig-zag pattern.

Start/Stop Clip Fasteners Needed

0.75 Clips needed for ever 1 lineal foot of decking. If clips will be used for last board, double the amount calculated above.

Special Patterns

When planning a unique pattern, you will need to adjust the framing to support the surface pattern. Please refer to the span and gapping chart on pages 18 and 19. Many decks are designed to take advantage of angles, as shown below.



Herringbone pattern



Tile pattern



Picture Frame pattern

Rooftop and Sleeper Deck Systems

Sleeper Deck Systems

A sleeper system is a buffer between the solid surface and Trex®. Drainage, access and airflow are critical. Water must be able to flow through and away from the deck. For repairs and removal of debris, joist system access is necessary. Good airflow will keep the decking dry and good-looking.

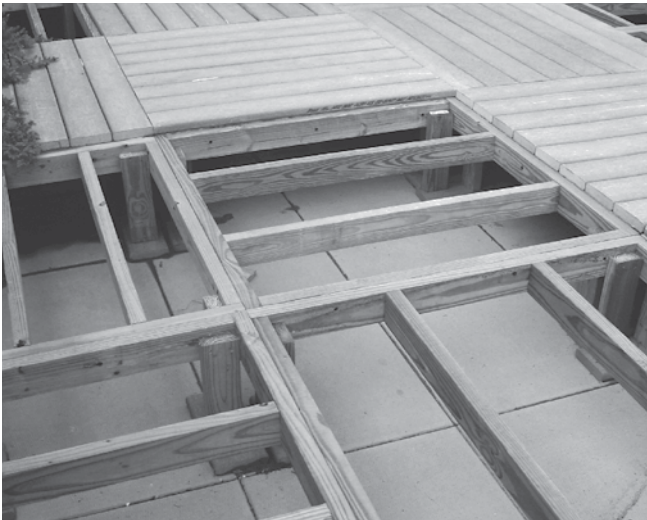

Roof deck notes

- Consult your building code authority for proper detail on railing installation to the roof structure.
- If access to the roof is desired, the Trex deck must be built in removable sections or with removable fasteners to allow access to roof.
- The sleeper joists must be attached to the roof structure in a manner that stabilizes the deck frame. Failure to do so may result in a poor structure which will compromise deck performance.

Sleeper system notes

- Surface below the deck must be pitched for proper drainage.
- 1/4" - 1/2" (0.64 - 1.3 cm) gap abutting walls or other fixed objects.
- Gaps between deck boards should be 3/8" (1 cm) minimum on a sleeper system.
- Minimum height of a sleeper joist is 3 1/2" (9 cm).
- Trex, when used with a sleeper system, must be supported below its entire length and the supports must run the direction of the pitch of the roof to facilitate proper drainage.
- Trex Hideaway® fasteners are not appropriate for use with a sleeper system.

Code Compliance

Joist Spanning for Decking

Trex® decking meets all applicable national model building codes. The joists must be spaced on centers according to the chart below. Be sure that all joists are level and plumb. Trex decking must span at least three joists. For load-bearing applications such as hot tubs, planters, etc., consult a local building engineer or inspector for span recommendations. Paint the top of your joists black to minimize the appearance of joists through spaces between boards.

Code Listings

Trex complies with all major model building codes and has been evaluated by the International Code Council evaluation service.

Trex Complies with these Model Building Codes:

- 1997 Uniform Building Code (UBC).
- 1999 Standard Building Code (SBC).
- 2006 International Residential Code (IRC).
- 2006 International Building Code (IBC).
- International One and Two Family Dwelling Code 1998.
- BOCA® National Building Code/1999 (BNBC).
- Trex Decking is included in the National Research Council of Canada's Registry of Product Evaluations. See trex.com for CCMC Evaluation Report 13125-R.

For an MSDS please visit trex.com.

Adjust Joist Spanning to Accommodate Angled Decking Patterns*

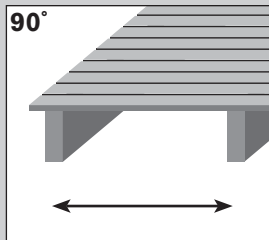

90°

Perpendicular to joists. See chart below.

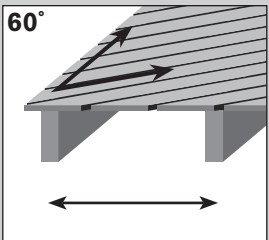

60°

At a 60° angle, maximum joist spanning is 2" less than below chart.

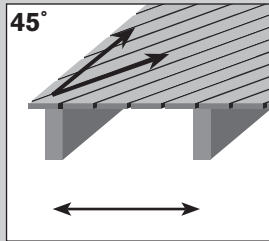

45°

At a 45° angle, maximum joist spanning is 4" less than below chart.

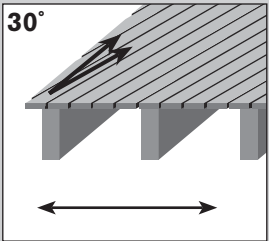

30°

At a 30° angle, maximum joist spanning is 1/2 of the below chart.

Fire Defense* & Escapes

• The Fire Defense® & Escapes board meets California and San Diego Fire Code Requirements. For California, those requirements are an ASTM E84 Class B Flame Spread and meets 12-7A-4 Part A Underflame requirement. For San Diego, those requirements are that it meets 12-7A-4 Part A Underflame and Part B Burning Brand (all parts). Trex Escapes meets ASTM E84 Class A Flame Spread and CA SFM 12-7A-4 Underflame and Burning Brand requirements. For more information, e-mail question@trex.com or call 1-800-BUY-TREX (1-800-289-8739).

Trex Decking and Railing Span Chart (on centers)			
	Residential Decks, Light Duty Docks, Residential/Daycare Playground	Commercial Decks, Boardwalks & Marinas	
Decking Loading	100psf (4826 Pa)	100psf (4826 Pa)	200psf (9576 Pa)
1" Boards	16" (40.6 cm)	16" (40.6 cm)	12" (30.5 cm)
2 x 4	20" (50.8 cm)	20" (50.8 cm)	16" (40.6 cm)
2 x 6 Boards	24" (70 cm)	24" (70 cm)	16" (40.6 cm)

Maximum Railing Span for all Applications* (on center of posts)	
Transcend™ Railing	96" (244 cm)
Designer Railing / Traditional Railing	72" (183 cm)

*Only available in select areas

Gapping

Trex® decking must be gapped, both end-to-end and width-to-width. Gapping is necessary to facilitate proper drainage and for the slight thermal expansion and contraction of the Trex decking boards. Another reason for gapping is to account for shrinkage of the wood joist system. Following the proper gapping requirements will ensure that your deck will look great year after year.

- Always follow Trex recommended gapping guidelines.
- Maximum allowable overhang for Trex is 4" (10 cm) perpendicular.
- All decks require air circulation to keep them dry and looking good. Leave openings under the decking or increase gapping to 3/8" (1 cm) to improve air flow.

Fascia

- Trex used as vertical siding or fascia around the base of a deck must be gapped the same as decking to allow for air flow.
- Fascia should be attached every 12" (30.5 cm) with three Trex-approved screws. The top screw should be placed 1" (2.5 cm) from the top of the rim joist, the second screw in the center of the rim joist and the third screw 1" (2.5 cm) from the bottom of the rim joist.

Width-to-Width Gap

Below 40° F* (4.5 C)*	3/8" (1 cm)
Above 40° F* (4.5 C)*	1/4" (0.6 cm)

*Temperature at installation.

End-to-End/End-to-Width & Abutting Gap

	End-to-End/ End-to-Width	Abutting
Below 40° F* (4.5 C)*	3/16"(0.5 cm)	1/2" (1.3 cm)
Above 40° F* (4.5 C)*	1/8" (0.3 cm)	1/4" (0.6 cm)

*Temperature at installation.

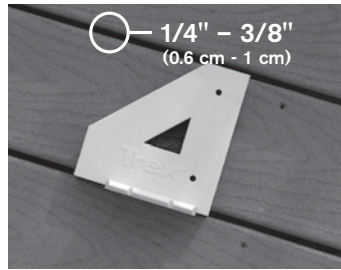

Width-to-width

The minimum required width-to-width gapping is 1/4" (0.6 cm). When installing in temperatures below 40° F (4.5 C), 3/8" (1 cm) gapping is recommended. For docks and heavily wooded areas, Trex recommends a 3/8" (0.6 cm) gap as well. No gapping should ever exceed 1/2" (1.3 cm).

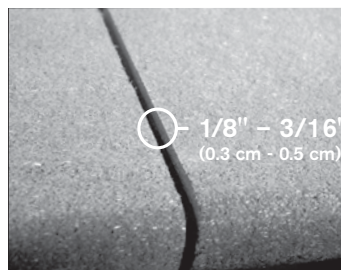

End-to-end/End-to-width

Trex decking must also be gapped end-to-end, based upon the temperature at installation. See chart at left. For fastening tips, see page 12.

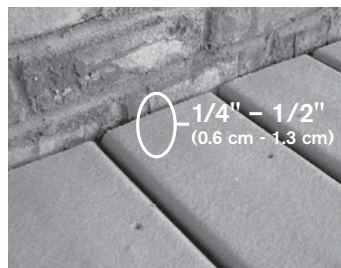

Abutting Solid Objects

Trex decking must also be gapped 1/4"- 1/2" (0.6 - 1.3 cm) depending upon the temperature at installation when decking is abutting a wall. See chart at left.

Special Note:

When using recommended hidden fasteners, a designated gap size is already established by the placement of the hidden fastener.

Stairway Assembly

Stairway Detail

- Stair treads built with Trex® meet requirements set forth by the major national building codes. Consult your local municipality for specific requirements.
- Fasten treads continuously across at least four stringers
- See chart for center-to-center spacing of profiles
- Dress the sides of the stringers and risers with Trex Fascia or Trim for a finished look
- Most model building codes require the stairs be constructed under the following requirements:
 - Stairways must be at least 36" (91.5 cm) wide
 - Stair treads must be at least 11" (28 cm) wide*
- Gapping between Trex boards on stairways must be 1/4" – 3/8" (0.6 - 1 cm)
- The overhang of the stair tread is not to exceed 1/2" (1.3 cm)

Maximum Spacing on Center of Joist	
2 x 6, 1" Boards	12" (30.5 cm)
Brasilia & 5" Contours	9" (24 cm)

FACT:

Trex rails meet all major building codes for use as a guardrail system. Local municipalities may require a graspable handrail on stairways. Check with your local building code official for local requirements. See Trex ADA Handrail System on pages 53-56.

*5" wide Contours will require gapping at the riser to meet the 10" tread requirement with 3/4" – 1-1/4" (2 - 3.2 cm) nosing.

5" wide Contours Stairs Options:

1. Using two deck boards
 - a. 3/8" (1 cm) gap at riser and between each board
2. Using two deck boards
 - a. 1/2" (1.3 cm) gap at riser and 1/4" (0.6 cm) gap between each board
3. Using a Feature Board – ripped piece of Contours
 - a. 1-1/8" (3 cm) from the edge
 - b. Feature Board should be installed with factory end side facing up
 - c. There should be no gap at the riser
 - d. Install as follows:
 - Riser, Full board, 1/4" (0.6 cm) gap, Feature Board, 1/4" (0.6 cm) gap, Full board
 - Riser, Feature Board, 1/4" (0.6 cm) gap, Full Board, 1/4" (0.6 cm) gap, Full board layout

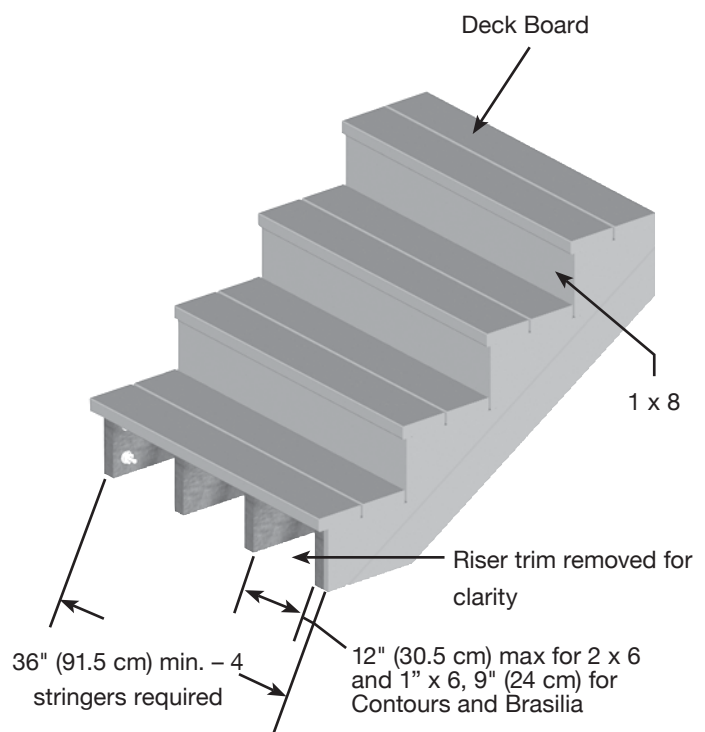

Bending Trex®

Bending Trex Requirements and Recommendations:

- Installing curved profiles will take considerably more time than installing straight profiles.
- Bending Trex profiles is difficult but can be done with care and patience.
- Bending Trex usually requires 2 or 3 people for easier installation.
- Trex profiles have a minimum radius that they can be bent to. See the chart for additional information regarding this.
- Bending Trex profiles places them under considerable stress. Boards may break. Common causes are as follows:
 - Boards are not hot enough
 - Bending is being done at a rate faster than 1” (2.5 cm) per second
 - Boards are not being handled properly when removed from heater (boards are very soft when first removed and can break if not handled properly – usually by 2 or more people)
- Heaters of 140,000 BTU (148,000 KJ) or larger are recommended.
- Joist spacing must be reduced by 4” (10.2 cm) to support curved decking.
- When attaching bent Trex profile to joists, attach fasteners (whether standard composite decking screws or hidden fasteners) to inside of curve first, until entire board is fully in place. Then attach remainder of outside fasteners.

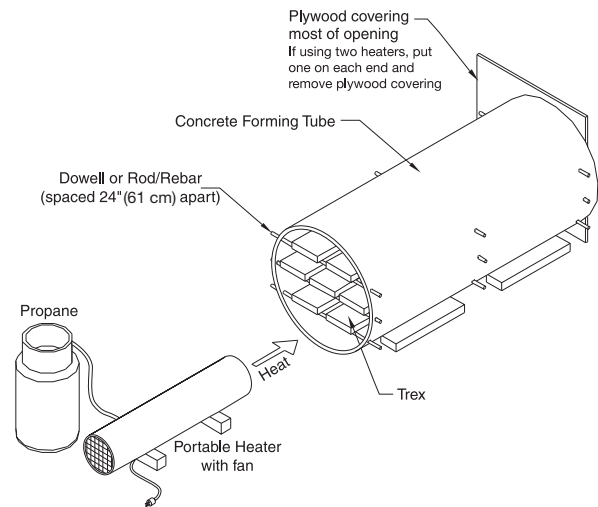

Special Notes

- Trex Decking cannot bend at a radius of less than 15’ (4.5 m)
- Designer Handrail can be bent but bending radius is 20’+ (6 m +)
 - Very difficult – expert level
 - Should contact local code official when bending railing
 - Follow bending guidelines for 15’ (4.5 m) decking profile
- Due to technical and equipment requirements, Trex Transcend™ railing can be curved off site by a professional. To have your Transcend rail curved, please contact Bugh, Inc. through their website at bughinc.com

Bending Trex®

Bending Trex Tips and Tricks:

1. Measure the radius that you want to achieve for your decking surface. Remember to refer to chart below for minimum radius for Trex profiles.
2. Build a fixture/jig to these dimensions. Refer to pictures.
3. Once boards are done heating, quickly and carefully place board (one at a time) in the fixture. Refer to pictures.
4. Allow boards to cool entirely within this fixture before attaching to joist decking.
5. Cooling process can be accelerated by using a garden hose to spray boards until they are cool to the touch.
6. When you remove boards from fixture (remove only one at a time), the board will automatically try and start to return to its original shape. Thus it is important to install the board as quickly as possible. Remember to attach fasteners to inside of curve first for entire length of board, then follow with remaining outside fasteners.



Boarding Type	Bending Radius	Method	Board Surface Temp	Difficulty Level
All	25'+ (7.6 m +)	Tube & Heater	185° - 200° F (85 - 94 C)	Intermediate
All	20'+ (6 m +)	Tube & Heater	185° - 200° F (85 - 94 C)	Intermediate
All	15 - 20' (4.5 - 6 m)	Tube & 2 Heaters	200° - 220° F (94 - 104 C)	Expert

Trex® Traditional Anchored Railing

Anchored Guardrail Assembly Detail

A. Trex 4x4 Railpost™

Note: Post Sleeves cannot be used in this application.

B. Deck board Top Rail

Note: 5" Contours and Escapes cannot be used.

C. 2x4 Lateral Top Rail

D. Trex Designer Balusters

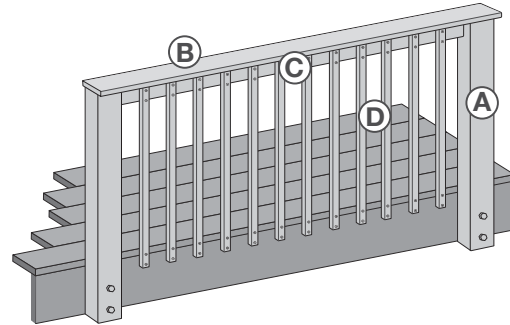

Step 1 - Trex Railpost™ Installation

Only for use with Trex Railpost™

Attach the Post using ½" (1.3 cm) carriage bolts.

- Post span = maximum 6' (1.8 m) on center
- Minimum joist size is 2x8
- Top bolt must be 1" (2.5 cm) from top of joist
- Bottom bolt must be 5 1/8" (13 cm) from top bolt

Trex does not endorse notching any post when required to perform as a guard rail system.

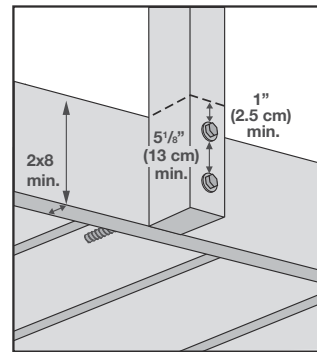

Step 2 - Top Rail Installation

Only for use with Trex Railpost™

A. Place a deck board across the top of each post (overhang 1½" (3.8 cm) towards the deck for 2x4 lateral board installation).

B. Attach to the top of each post with two exterior approved screws positioned diagonally.

C. Use scarf cut where two deck boards meet.

* *If installing below 40°F (4.5 C) leave 1/8" (0.3 cm) gap between deck boards for expansion.*

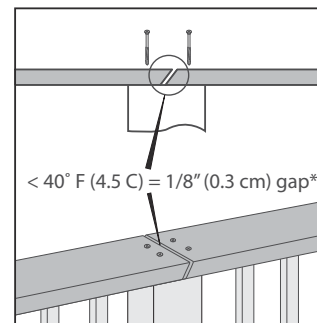
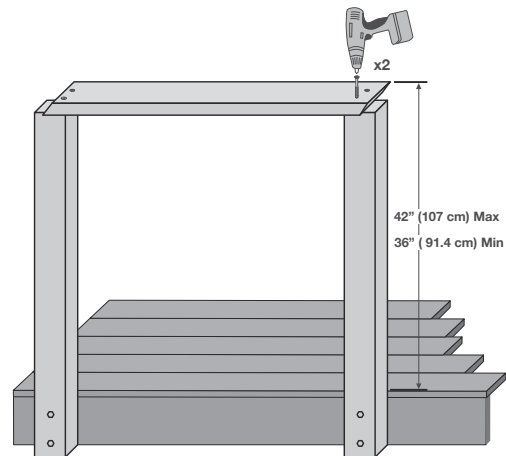

Trex® Traditional Anchored Railing

Step 3 - Lateral Rail Installation

A. Place lateral rail across the Trex Railposts directly under the top rail and fasten into the posts using two 2½" (6.4 cm) exterior approved screws positioned diagonally. Pre-drilling may be necessary.

B. Attach the top rail to the lateral rail every 12" (30.5 cm).

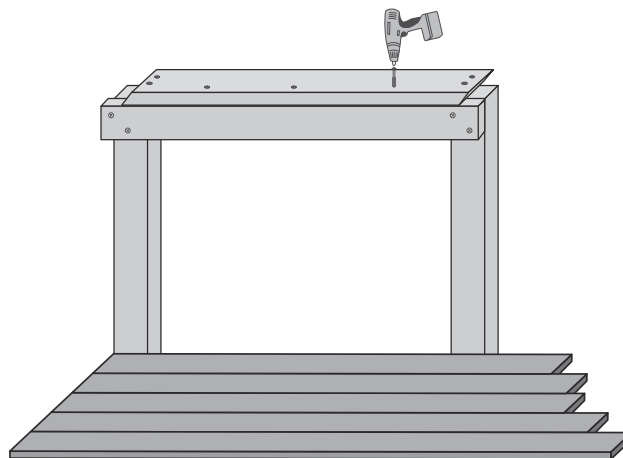

Step 4 - Baluster Installation

A. Cut balusters to the desired length based on the top rail height.

B. Pre-drill the balusters with 2 holes at the top and bottom to ease fastening into the lateral rail and ledger board. Placement of holes vary based on personal preference.

C. Locate the middle of the lateral rails and fasten the first baluster here using two 2½" (6.4 cm) exterior approved screws. Continue balusters to the left and right spacing them a maximum of 3⅝" (9.2 cm) in between or 5" (13 cm) on center.

Note: Always consult your local building department prior to purchase and installation.

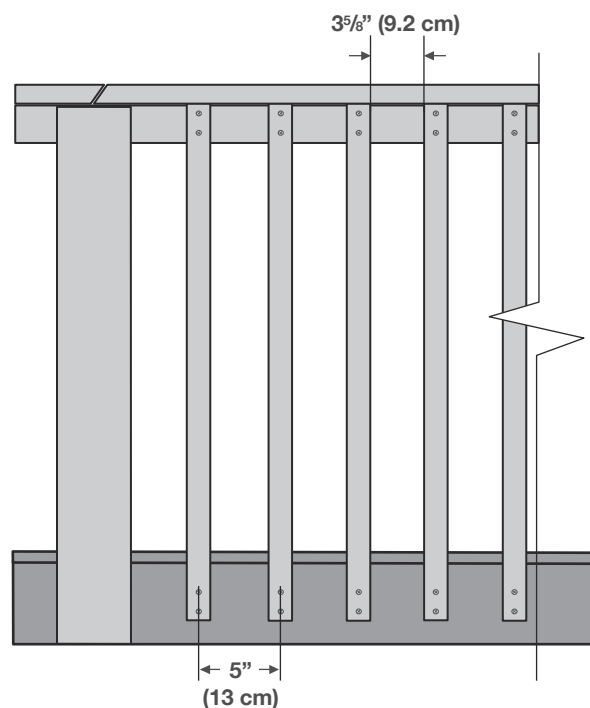

NOTES: The Trex guardrail system complies with current BOCA, ICBO, SBCCI and ICC model codes for a guardrail system. See local building codes for other requirements. For more detailed installation instructions, visit trex.com.

Trex® Traditional Raised Railing

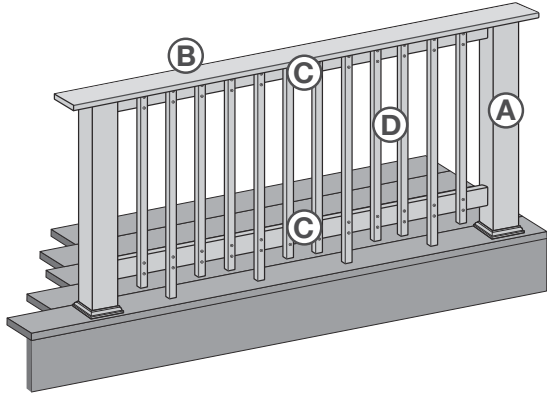

Option 1 - Rails Mounted Between Posts with standard Trex Designer Balusters

- A. Trex 4x4 Rail Post or Pressure Treated Post with Trex Designer Post Sleeve or Trex Artisan 4x4 Post Sleeve
- B. Deck board Top Rail
Note: 5" Contours and Escapes cannot be used.
- C. 2x4 Lateral Top & Bottom Rail
- D. Trex Designer Balusters

Option 2 - Rails Mounted On Side of Post with standard Trex Designer Balusters

- A. Trex 4x4 Rail Post
Note: Post Sleeves cannot be used in this application.
- B. Deck board Top Rail
Note: 5" Contours and Escapes cannot be used.
- C. 2x4 Lateral Top & Bottom Rail
- D. Trex Designer Balusters

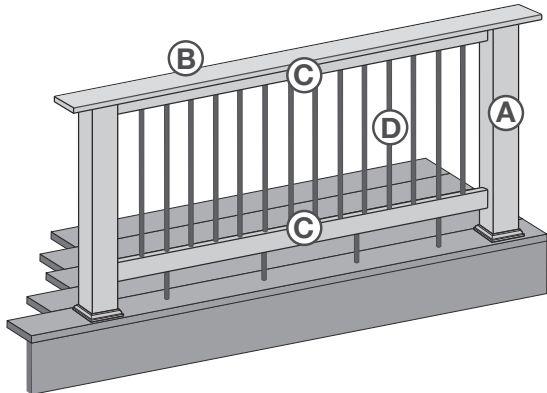
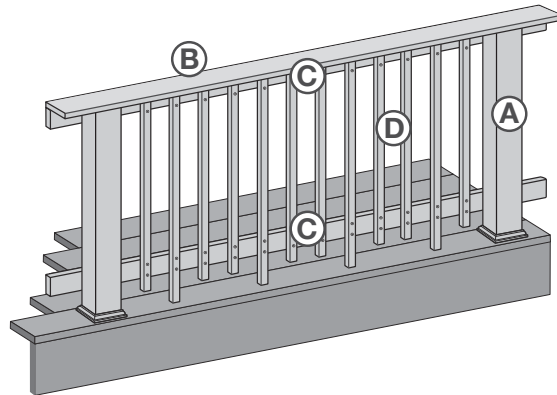

Option 3 - Rails Mounted Between Posts with Contemporary Balusters

- A. Trex 4x4 Rail Post or Pressure Treated Post with Trex Designer Post Sleeve or Trex Artisan 4x4 Post Sleeve
- B. Deck board Top Rail
Note: 5" Contours and Escapes cannot be used.
- C. 2x4 Lateral Top Rail
- D. Trex Contemporary Balusters

Option 4 - Rails Mounted Between Posts with Architectural Balusters

- A. Trex 4x4 Rail Post or Pressure Treated Post with Trex Designer Post Sleeve or Trex Artisan 4x4 Post Sleeve
- B. Deck board Top Rail
Note: 5" Contours and Escapes cannot be used.
- C. 2x4 Lateral Top Rail
- D. Trex Architectural Balusters

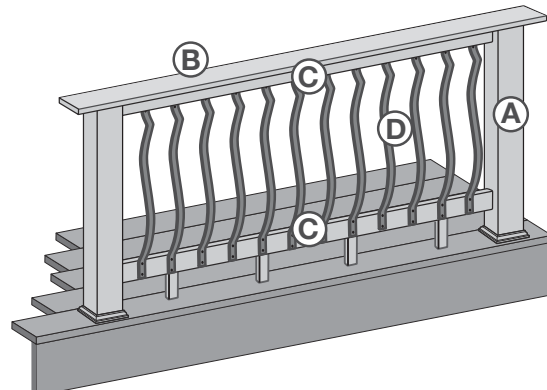

Trex® Traditional Raised Handrail

Step 1 - Attaching the Posts and Post Skirts (Rails mounted to side of post)

Note: For Option 2 you cannot use Post Sleeve

Trex Railpost™ or Pressure Treated Post Installation

- A. Post span = maximum 6' on center
- B. Attach the Post using 1/2" carriage bolts.
 - Minimum joist size is 2x8.
 - Top bolt must be 1" from top of joist.
 - Bottom bolt must be 5 1/8" from top bolt.

Note: blocking can be added for extra strength.

Trex does not endorse notching any post when required to perform as a guard rail system.

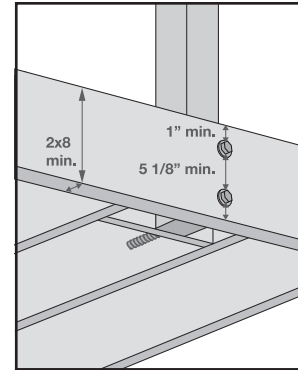

Post Skirt or Post Sleeve Skirt

- A. Slide a Post Skirt over Post.
- B. If using Post Sleeve:
 - Slide Post Sleeve Skirt over post
 - Top bolt must be 1" from top of joist.
 - Slide Post Sleeve over pressure treated post & inside Post Sleeve Skirt

Note: blocking can be added for extra strength.

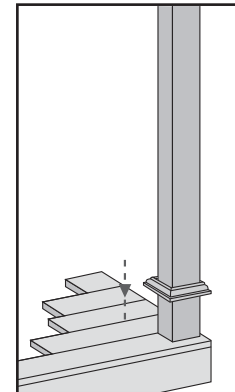

Step 2 - Top Rail Installation

Ⓐ

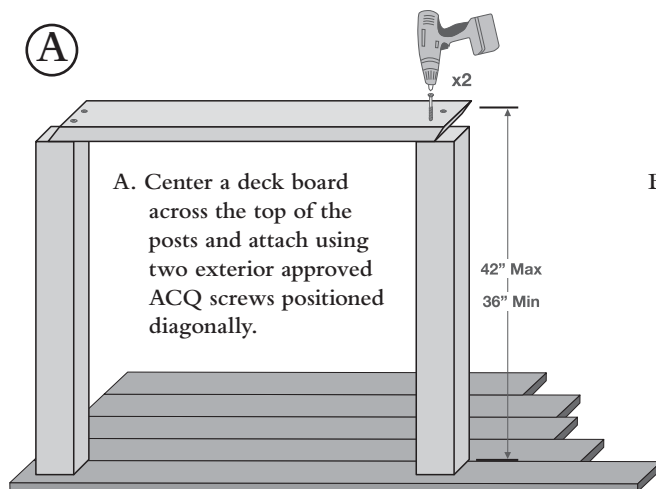

A. Center a deck board across the top of the posts and attach using two exterior approved ACQ screws positioned diagonally.

Ⓑ

B. Use scarf cut where two deck boards meet.
 * If installing below 40° F leave 1/8" gap between deck boards for thermal expansion.

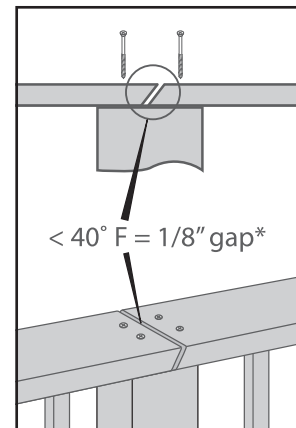

Trex® Traditional Raised Railing

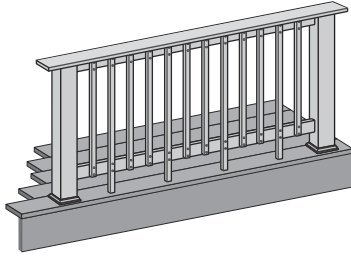

Option 1 - Rails Mounted Between Posts with Standard Trex Designer Balusters

Step 3 - Lateral Rail Installation

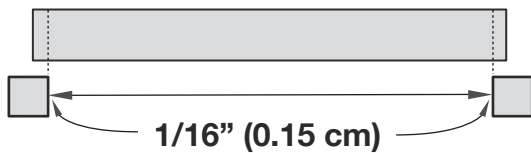

- A. Measure and cut 2x4 lateral rails to fit between posts.
1/16" (0.15 cm) gap each end for cold weather expansion.

- B. Center lateral rail directly under top rail for stability.
- C. Connect lateral rails (top & bottom) to posts using an L bracket or equivalent construction method.
- D. Using 2½" composite approved screws, attach the top rail to the lateral rail with one screw every 12" (30.5 cm).

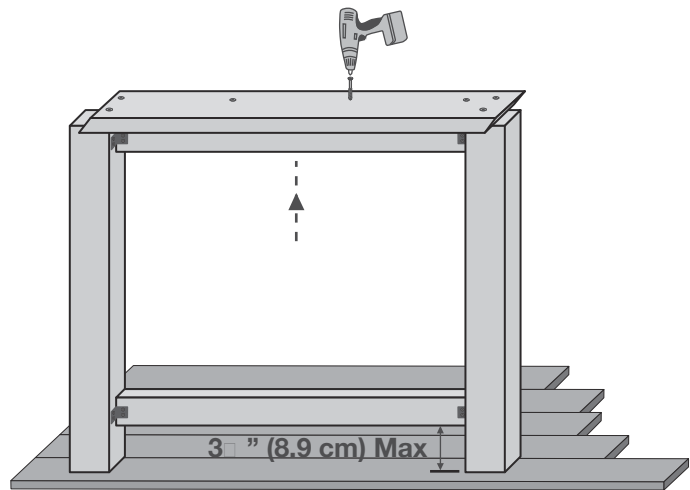

Step 4 - Baluster Installation (view flipped 180°)

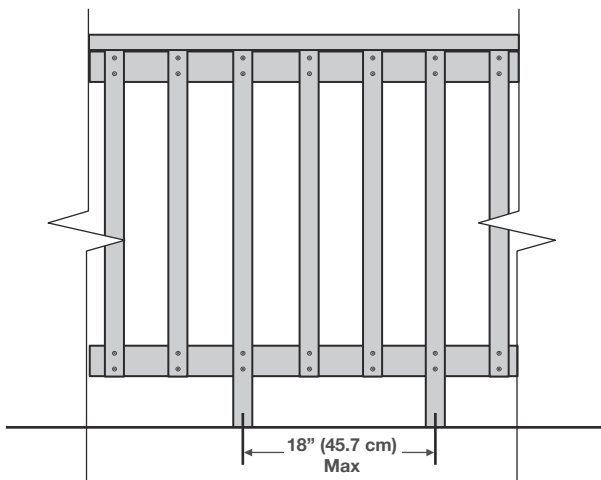

- A. Cut balusters to the desired length based on the top rail height and bottom rail placement.

Note: One baluster must extend to the decking surface every 18" (45.7 cm) (typically 4 for a 6' / 1.8 m installation)
- B. Pre-drill the balusters with 2 holes at the top and bottom to ease fastening into the lateral rail. Placement of holes vary based on component selection and personal preference.
- C. Locate the middle of the lateral rails and fasten the first baluster here using two 2½" (6.4 cm) exterior approved screws. Continue balusters to the left and right spacing them a maximum of 3⅝" (9.2 cm) in between or 5" (13 cm) on center.

Note: Always consult your local building department prior to purchase and installation.

Trex® Traditional Raised Railing

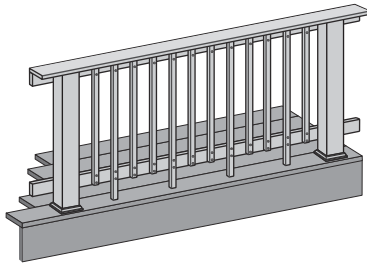

Option 2 - Rails Mounted on Side of Post with Standard Trex Designer Balusters

Note: Post sleeves cannot be used for this application.

Step 3 - Lateral Rail Installation

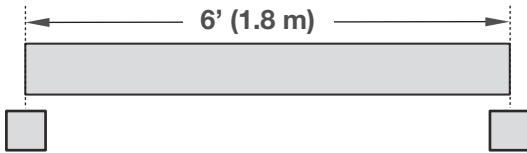

- A. Measure and cut 2x4 lateral rails. Top & bottom rail are equal to distance between posts on 6' (183 cm) center.

- B. Place 2x4 lateral rail directly under top rail for stability.
 C. Connect 2x4 top & bottom lateral rails to Trex 4x4 Rail Posts using 2 screws (#12 x 3"/7.6 cm).
 D. Using 2½" (6.4 cm) composite approved screws, attach the top rail to the lateral rail with one screw every 12" (30.5 cm).

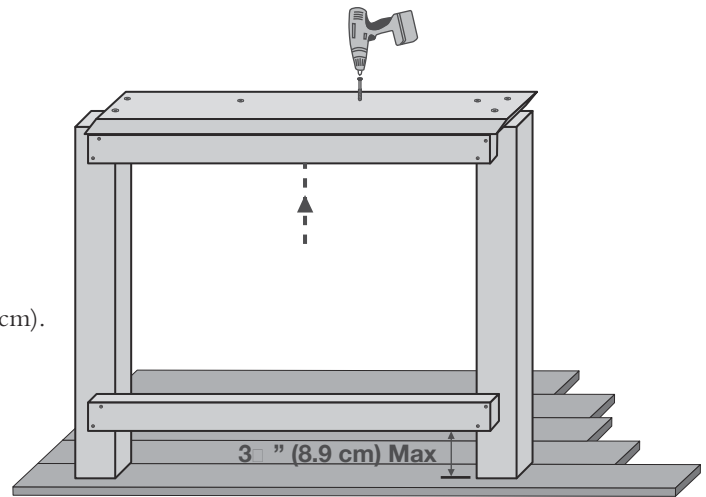

Step 4 - Baluster Installation (view flipped 180°)

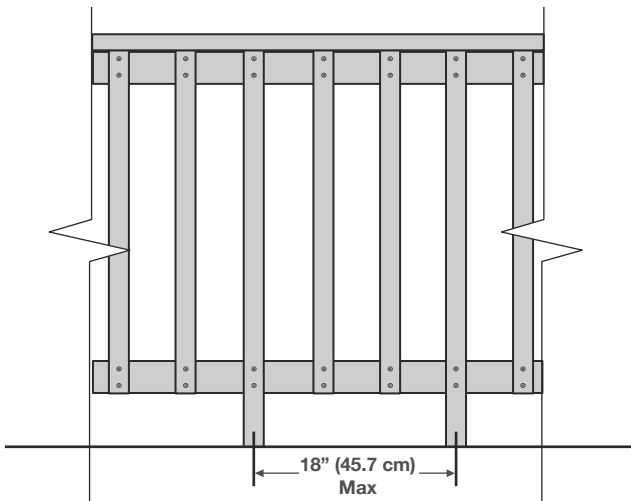

- A. Cut balusters to the desired length based on the top rail height and bottom rail placement.
Note: One baluster must extend to the decking surface every 18" (45.7 cm) (typically 4 for a 6'/1.8 m installation)
 B. Pre-drill the balusters with 2 holes at the top and bottom to ease fastening into the lateral rail. Placement of holes vary based on component selection and personal preference.
 C. Locate the middle of the lateral rails and fasten the first baluster here using two 2½" (6.4 cm) exterior approved screws. Continue balusters to the left and right spacing them a maximum of 3⅝" (9.2 cm) in between or 5" (13 cm) on center.

Note: Always consult your local building department prior to purchase and installation.

Trex® Traditional Raised Railing

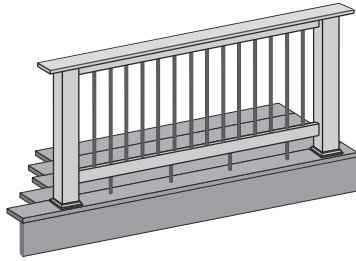

Option 3 - Rails Mounted Between Posts with Contemporary Balusters

Step 3 - Lateral Rail Installation

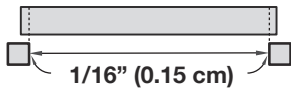

A. Measure and cut 2x4 lateral rails to fit between posts.

1/16" (0.15 cm) gap each end for cold weather expansion.

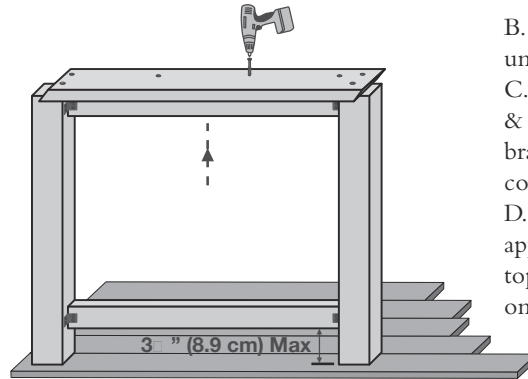

B. Center lateral rail directly under top rail for stability.

C. Connect lateral rails (top & bottom) to posts using an L bracket or equivalent construction method.

D. Using 2½" (6.4 cm) composite approved screws, attach the top rail to the lateral rail with one screw every 12" (30.5 cm).

Step 4 - Baluster Installation

For 36" (91.4 cm) rail height, use Trex 26" Contemporary Balusters - Part number BK3Q26RBK

For 42" (107 cm) rail height, use Trex 32" Contemporary Balusters - Part number BK3Q32RBK

A. Measure Baluster Spacing

Length of rail ____" ÷ 4.5 = ____ balusters

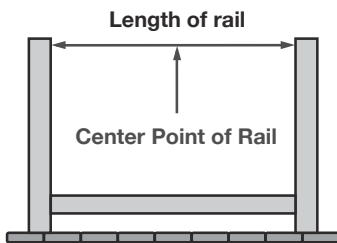

If number is odd: balusters will be centered.

If number is even: balusters will be offset 2¼" (5.7 cm) from center.

B. Measure Railing Height

Attach Baluster Connectors as shown below. 4½" (11.4 cm) on center.

Note: Purchase Level Baluster Connectors separately.

Black ¾" Horizontal Baluster Connectors: Part number BK075HCON

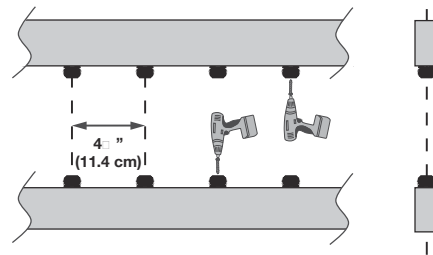

C. Install Balusters

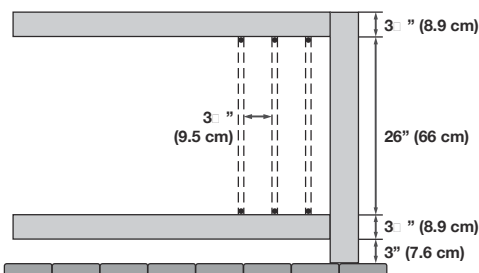

Use the measurements above to achieve a 36" (91.4 cm) railing height. Note: add 6" (15.3 cm) to distance between rails (31"/78.7 cm) to achieve a 42" (107 cm) railing height.

D. Install Footblocks (2 Options)

- Round balusters can be cut and used for footblocks every 18" (45.7 cm). These would be fastened in the same method as the balusters.

*Note: This step should be done when bottom 2x4 rails are being attached.

- Square balusters can also be used as footblocks. Install every 18" (45.7 cm) and toenail screws into footblock and bottom rail.

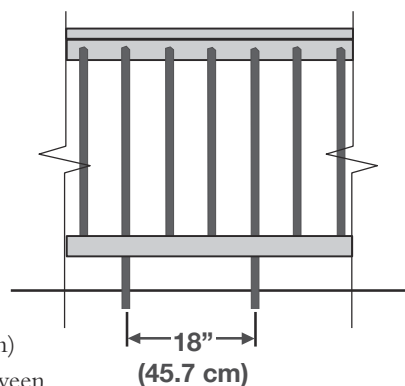

Trex® Traditional Raised Railing

Option 3 - Stair Section Instructions - with Contemporary Balusters

- For 36" rail height, use Trex 26" Contemporary Balusters - Part number BK3Q26RBK
- For 42" rail height, use Trex 32" Contemporary Balusters - Part number BK3Q32RBK
- Black 3/4" Stair Baluster Connectors - Part number BK075SCON

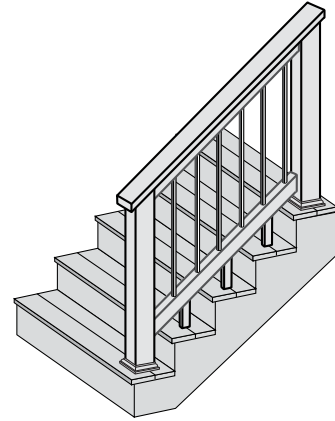

Step 1 - Measure Baluster Spacing

- Length of rail _____" ÷ 5.5 = _____ balusters
 - If number is odd: balusters will be centered
 - If number is even: balusters will be offset 2/4" from center

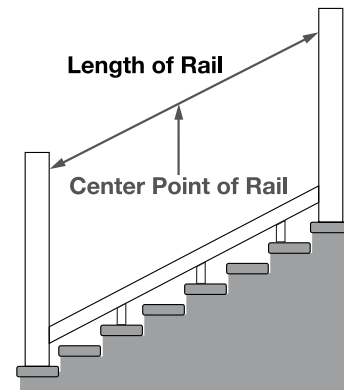

Step 2 - Attach Connectors

- Install Baluster Connectors on top & bottom rail as shown. 5 1/2" on center.
- *Note: Purchase Stair Baluster Connectors separately. Black 3/4" Stair Baluster Connector: Part number BK075SCON*

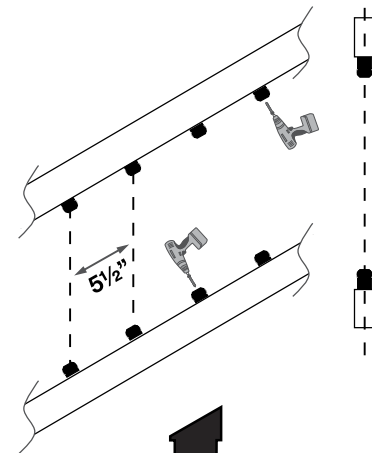

Step 3 - Install Balusters

- Attach Baluster Adapters in each end of balusters.

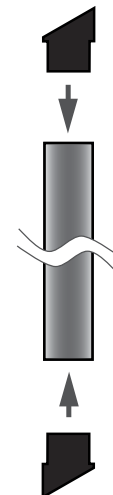

Trex® Traditional Raised Railing

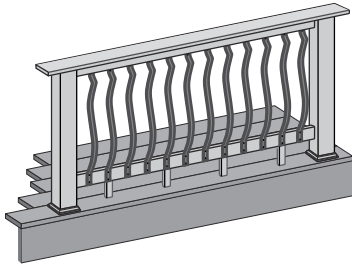

Option 4 - Rails Mounted Between Posts with Architectural Balusters

Step 3 - Lateral Rail Installation

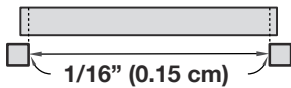

A. Measure and cut 2x4 lateral rails to fit between posts.

1/16" (0.15 cm) gap each end for cold weather expansion.

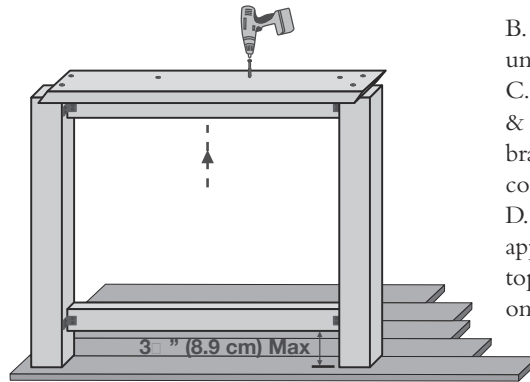

B. Center lateral rail directly under top rail for stability.
 C. Connect lateral rails (top & bottom) to posts using an L bracket or equivalent construction method.
 D. Using 2½" (6.4 cm) composite approved screws, attach the top rail to the lateral rail with one screw every 12" (30.5 cm).

Step 4 - Baluster Installation

For 36" (91.4 cm) rail height, use Trex 32¼" Architectural Balusters - Part number BK0132VBK
 For 42" (107 cm) rail height, use Trex 40" Architectural Balusters - Part number BK0140VBK

A. Measure Baluster Spacing

$$\text{Length of rail} \div 4.5 = \text{balusters}$$

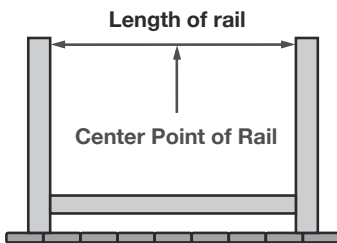

If number is odd: balusters will be centered.

If number is even: balusters will be offset 2¼" (5.7 cm) from center.

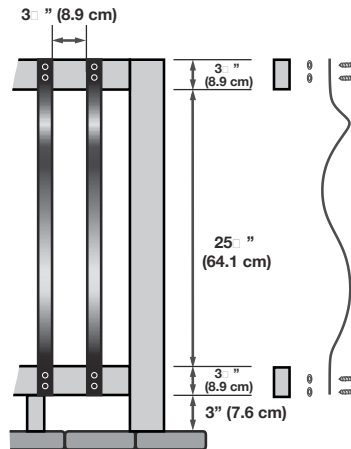

B. Measure Railing Height

Use the measurements at left to achieve a 36" (91.4 cm) rail height.
 Note: add 6" (15.2 cm) to distance between rails (31¼"/79.4 cm) to achieve a 42" (107 cm) rail height.

Hint

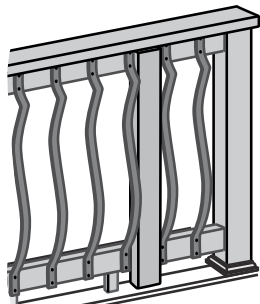

Hint: a 2x4 can be used for spacing the Architectural balusters.

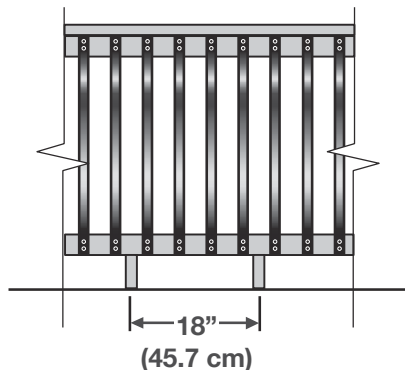

D. Install Footblocks

Square balusters must be cut and used for footblocks every 18" (45.7 cm). These would be fastened by toenailing screws thru footblock into bottom rail.

*Note: This step should be done when bottom 2x4 rails are being attached.

Trex® Traditional Raised Railing

Option 4 - Stair Section Instructions - with Architectural Balusters

- For 36" rail height, use Trex 32" Architectural Balusters - Part number BK0132VBK
- For 42" rail height, use Trex 40" Architectural Balusters - Part number BK0140VBK

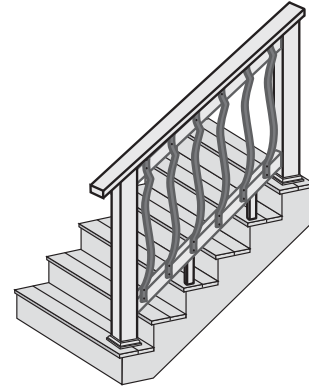

Step 1 - Measure Baluster Spacing

- Length of rail _____" ÷ 5.5 = _____ balusters
 - If number is odd: balusters will be centered
 - If number is even: balusters will be offset 2¾" from center

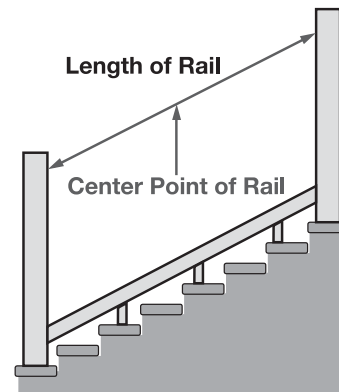

Step 2 - Attach Balusters

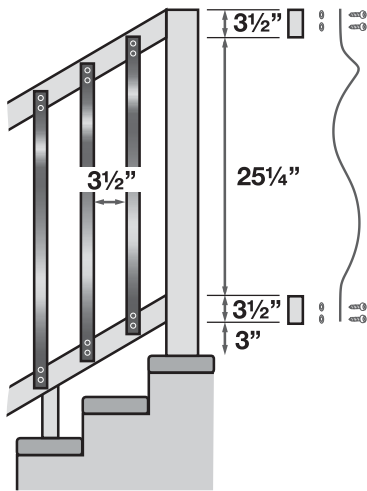

Hint

A 2x4 can be used for spacing the Architectural balusters.

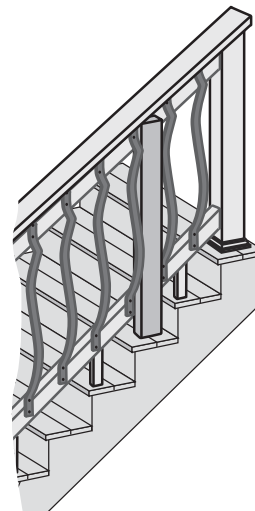



Designer Railing Assembly System

Trex® Railing Components

- | | |
|---|---|
| A Trex Designer Series® Top Rail | F TrexExpress™ Trex Railpost Assembly Tool |
| B Trex Designer Series Bottom Rail | G Trex Post Cap/Post Sleeve Cap |
| C Trex Railing Support Brackets | H Trex Post Skirt/Post Sleeve Skirt |
| D Trex Balusters | I TrexExpress Trex Designer Series Railing Post Sleeve Assembly Tool |
| E Trex Railpost™/Post Sleeve | |

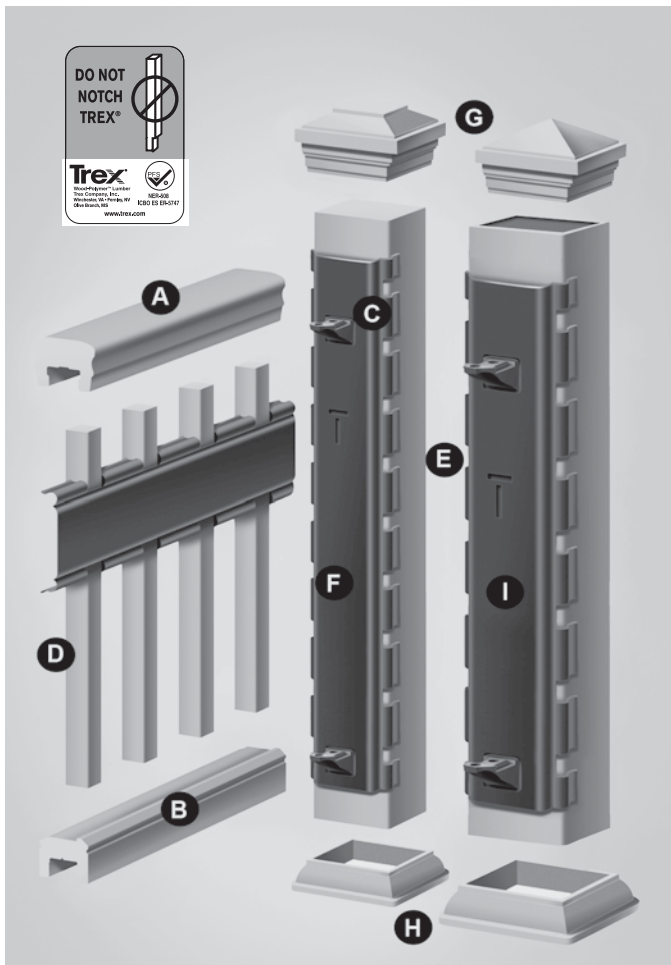

The TrexExpress™ Designer Railing Assembly System offers the builder something very valuable: time saved. In fact, you can finish a complete railing system as quickly and easily as wood.

How does the TrexExpress Designer Railing Assembly System work? For starters, it includes a Railing Support Bracket that can handle many assembly options. It removes the guesswork and simplifies the process.

The TrexExpress Designer Railing Assembly System is now available for solid Trex RailPosts™ and hollow Trex Designer Series Railing® 4 x 4 Post Sleeves.

The following illustrations of the Railing Support Bracket (RSB) depict the two different configurations the RSB will be used in during assembly of railings on decking and railings for stairways.

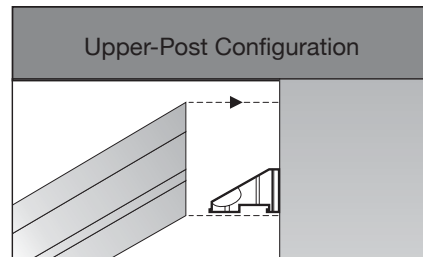

The RSB is assembled in this position for upper-post stair applications, with an angle of incline between 30° and 35°.

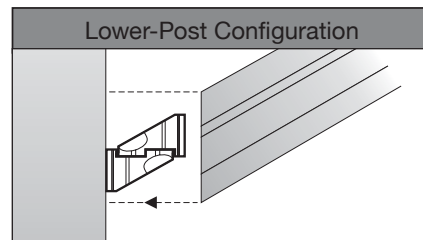

After installing one RSB in the horizontal application, snap together another bracket for each lower-post stair applications.

Trex Designer Series Railing® Installation Instructions

6 ft. (1.8 m) on center Railing Sections; 36" (91.4 cm) and 42" (106.7 cm) Railing Height

STEP 1 – Install Posts

The maximum post span for a Trex Designer Series Railing® kit is 72" (183 cm) on center of post. Attach the 4 x 4 pressure treated post (if using Trex 4 x 4 Post Sleeve) or Trex 4 x 4 solid Railpost to the rim joists with two 1/2" (1.3 cm) diameter carriage bolts. (Note: Finished post height with post cap may be adjusted for personal preference and appearance. Please note whether a 36" (91.4 cm) or 42" (106.7 cm) railing is being installed. **Do not notch posts.**) Bolts must be vertically spaced no less than 5 1/8" (13 cm) apart. The top bolt must be at least 1" (2.5 cm) from the top of the joist. The bottom bolt must be at least 1" (2.5 cm) from the bottom of the post. Minimum joist size is 2 x 8.

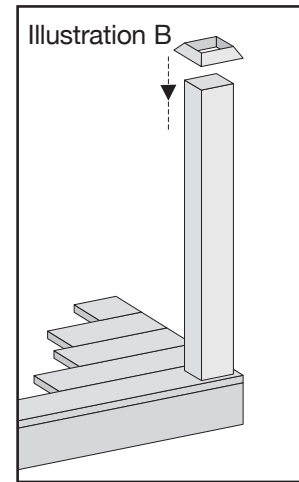
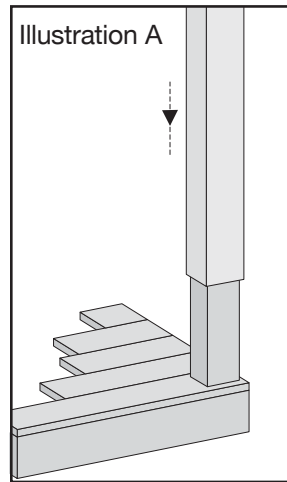

STEP 2 – Install Post Sleeves

(If using Trex 4 x 4 pressure-treated post)

Slide post sleeve over 4 x 4 pressure-treated post and rest on the deck surface. (See **Illustration A**) (Note: Do not use post sleeves as a structural post. Depending upon the size of the P/T post, shims may be required between the post and the 4 x 4 P/T post to create a better fit.)

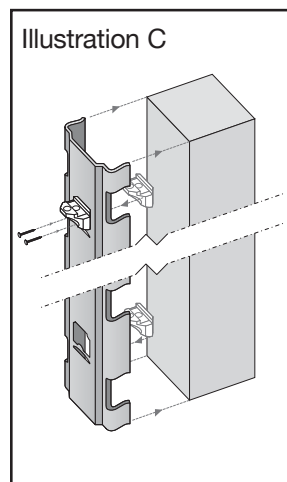

STEP 3 – Post Skirts

If Trex Post Skirts were purchased for either Trex RailPost™ or post sleeves, slide them over each post, resting them on the surface of the deck.

(See **Illustration B**)

STEP 4 – Set Railing Support Brackets (RSB)

Insert two RSB's into the appropriate TrexExpress™ Rail Assembly Tool (for Trex Solid 4 x 4's or Trex Designer Post Sleeves). Wrap the assembly tool around the post with the arrows on the horizontal label pointing up. (Note: If Post Skirts are in place, rest the bottom of the tool on top of the skirt. If skirts are not being used, place a 1 1/4" (3.2 cm) shim under the tool.) Attach each RSB to the post using two 2" (5 cm) tan screws provided. (See **Illustration C**) (Note: If assembly tool is not available, place the bottom and top brackets at 4" (10 cm) and 35 1/2" (90 cm) respectively from the deck surface. The brackets are installed with the sloped surface facing down. Measurements are to the top of the bracket.)

STEP 4 (ALTERNATIVE) – Set RSB for 42" (106.7 cm) Rail Height

For 42" (106.7 cm) railing height, insert two RSB's into the TrexExpress Rail Assembly Tool. Wrap the assembly tool around the post with the arrows on the horizontal label pointing up. (Note: If Post Skirts are in place, rest the bottom of the tool on top of the skirt. If skirts are not being used, place a 1 1/4" (3.2 cm) shim under the tool.) Attach the lower RSB to the post using two 2" (5 cm) tan screws provided. Remove the tool from the lower bracket, and then reposition the top of the tool 6" (15.3 cm) above the previous position. Finally, secure the upper RSB to the post using two 2" (5 cm) tan screws. (Note: If assembly tool is not available, place the bottom and top brackets at 4" (10 cm) and 41 1/2" (105.4 cm) respectively from the deck surface. The brackets are installed with the sloped surface facing down. Measurements are to the top of the bracket.)

Trex Designer Series Railing® Installation Instructions

STEP 5 — Top & Bottom Rail Layout and Baluster Spacing

Place the bottom rail on its side; ensuring the side with the lip is up. Position the assembly tool, with the legs facing up, next to the bottom rail and set the balusters in designated slots. Then insert the balusters into the channel of the top rail. **(See Illustration D)** Align top and bottom rails, making sure the distance from the end of the top and bottom rail to the first baluster are equal on both ends. *(Note: If Railing Assembly Tool is not available, maximum spacing is 5" (13 cm) on center or 3 5/8" (14.3 cm) between balusters.)*

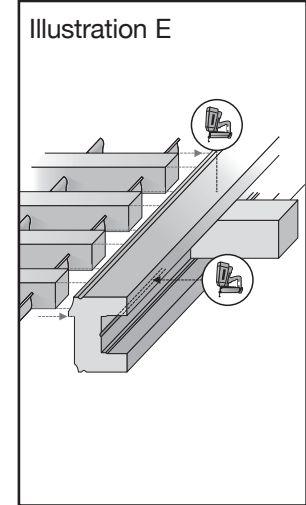
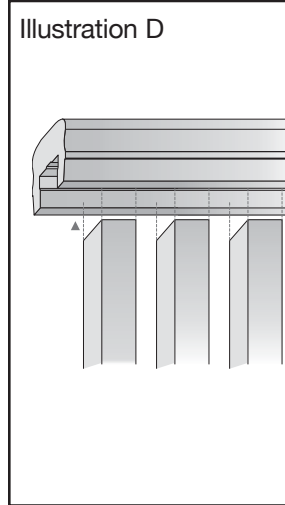

STEP 6 — Securing Balusters to Bottom Rail

With the assembly tool next to bottom rail, hold the baluster in contact with the lip of the bottom rail and nail a 2"-16 gauge finish nail through the underside of the bottom rail into each baluster. **(See Illustration E)** *(Note: For added stability, pre-drill through the bottom rail into the baluster and attach with a #8 - 2" (5 cm) screw. Groove in the bottom rail indicates the center location of the baluster for nailing.)*

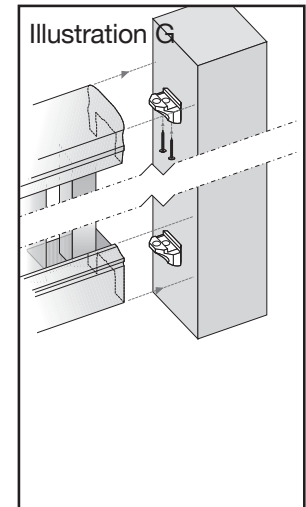
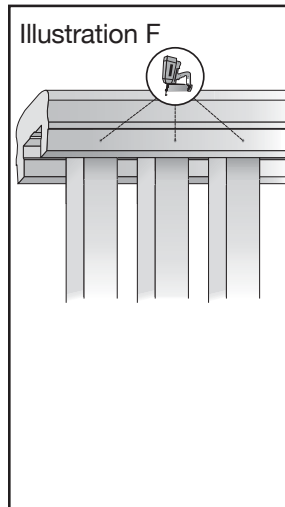

STEP 7 — Securing Balusters to Top Rail

Slide the assembly tool up next to the top rail. Check the alignment so it is the same distance from the first baluster as the bottom rail. Secure each baluster through the lower side portion of the top rail into each baluster using a 2" (5 cm)-16 gauge nail. **(See Illustration F)** *(Note: For added stability, nail through both sides of the top rail. Hold nail gun perpendicular to baluster to be sure the nail drives securely into the baluster.)*

STEP 8 — Attach Support Blocks

Nail a 2"-16 gauge finish nail through the sides of the bottom rail into the support blocks. **(See Illustration E)** Support blocks are approximately 3 1/2 - 4" (9 - 10 cm) long and are required every 18" (46 cm).

STEP 9 — Securing Railing Section to the Posts

Place the assembled railing section onto the RSBs previously secured to posts. **(See Illustration G)** Secure the top rail to the post using two 1 1/2" (3.8 cm) green screws. Secure the bottom rail by installing a screw through the top of the bottom rail into the outermost hole of the RSB. The bottom rail can also be secured to the post using 16 gauge finish nails, toe nailed through the side of the bottom rail.

Position the nail 1 1/2" (3.8 cm) up from the bottom of the rail and 1" (2.5 cm) in from the post.

STEP 10 — Finishing Up

Final post height is primarily due to personal preference. Once determined, the post sleeve can be trimmed. Be sure to cut the top of the post square and finish with a post cap.

Note: Position of Bottom Rail lip is not a structural component. It is recommended it be consistently installed inside or outside.



Trex Designer Series Railing® Stair Railing Instructions

6 ft. (1.8 m) on center Railing Sections; 36" (91.4 cm) and 42" (106.7 cm) Railing Height

STEP 1 – Install Posts

Install posts, sleeves and skirts (if applicable) according to the level railing instructions.

STEP 2 – Bottom RSB Location on Upper and Lower Post

- Determine length and angle of the top and bottom rail. (See *Illustration H*). Trim and test the rails for proper fit.
- Position the bottom rail between the posts and set to proper height from tread nosing. Support on blocks cut from scrap material. (Note: Check your local building code for railing height requirements.)
- Mark the underside of the bottom rail on both upper and lower posts where they intersect.
- On the upper stair post, center and secure the bottom bracket using two 2" (5 cm) tan screws (sloped surface facing up) with the top of the bracket on the mark made in the Step 2c.
- Center and secure the bottom bracket (sloped surface facing down) using two 2" (5 cm) screws to the lower stair post with the top of the bracket on the mark made in Step 2c.

STEP 3 – Top RSB Location on Upper and Lower Stair Post

- Determine the height of the top rail.
- Follow Step 2d - 2e to install the railing brackets on the upper and lower post.
- Take a second bracket, turn it upside down and interlock it into each of the brackets on the lower stair post. (See *Illustration I*)

STEP 4 – Cut the Balusters, Top and Bottom Rails to Length

Measure and cut balusters to length with correct angle.

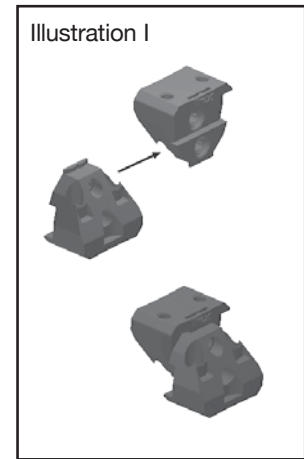
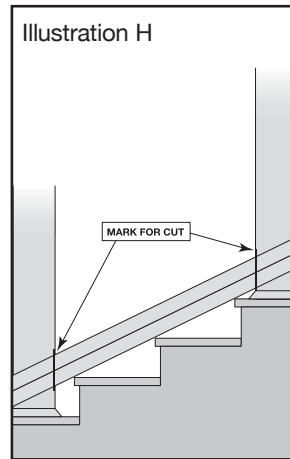

STEP 5 – Assemble Rail Section

Follow Steps 6 – 8 of the level railing section to complete stair railing installation.

STEP 6 – Securing Stair Railing Section to the Posts

Place the assembled railing section onto the Railing Support Brackets previously secured to posts. Secure the top rail to the post using two 1-1/2" (3.8 cm) green screws. Secure the bottom rail by installing a screw through the top of the bottom rail into the outer most hole of the RSB. The bottom rail can also be secured to the post using 16 gauge finish nails, toe nailed through the side of the bottom rail. Position the nail 1 1/2" (3.8 cm) up from the bottom of the rail and 1" (2.5 cm) in from the post.

STEP 7 – Attach Support Blocks

Measure and cut support blocks. Nail through the sides of the bottom rail into the support blocks. These are required every 18" (46 cm).

STEP 8 – Finishing up

Final post height is primarily due to personal preference. Once determined, the posts can be trimmed. Be sure to cut the top of the post square and finish with a post cap.

Trex rails meet all major building codes for use as a guardrail system. Local municipalities may require a graspable handrail on stairways. Trex offers an ADA code-compliant hand rail system. Check with your local building code official for local requirements.

Trex Transcend™ Railing

Dimensions for the tempered glass:

Height: 25, length: 109, width: 51, length: 11

Height: 31, length: 109, width: 25, width: 51, length: 11

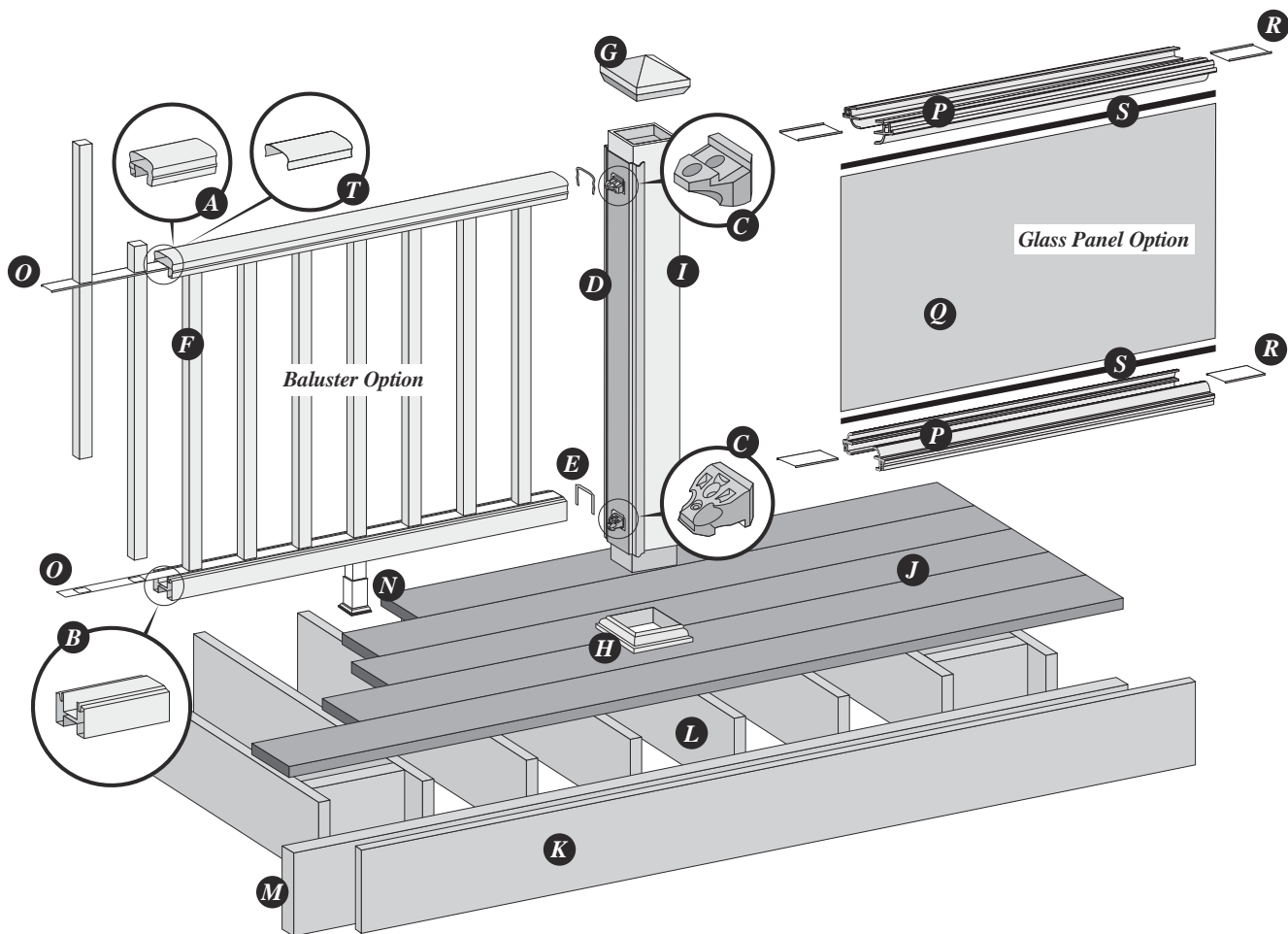

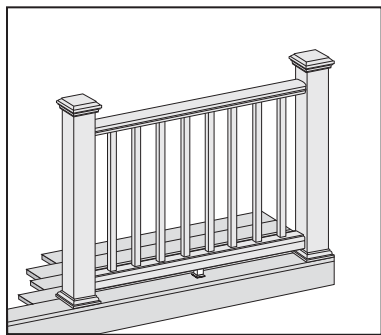

Standard Railing

Follow instructions for Standard Transcend assembly.
Cutting Post Sleeves is NOT required.

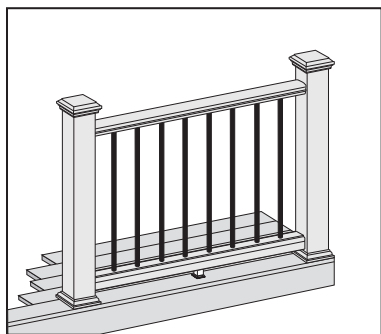

Contemporary Style Railing

Follow instructions for Standard Transcend assembly,
substituting metal balusters for square balusters.

Cutting Post Sleeves is NOT required.

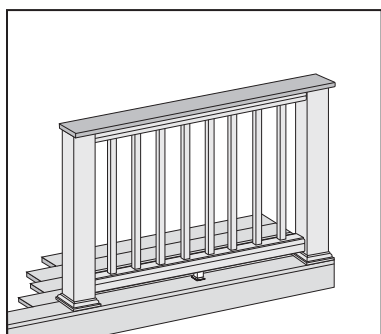

Classic Style Railing

Follow instructions for Classic assembly.
Deckboard over the top of posts.
Only for use with 4x4 Post Sleeve.
Purchase of Universal rail kit required.

Post Sleeves WILL need to be cut.

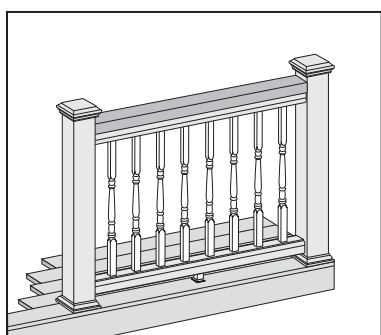

Colonial Style Railing

Follow instructions for Colonial assembly.
2x4 board between the posts.
Purchase of Universal rail kit required.
Cutting Post Sleeves is NOT required.

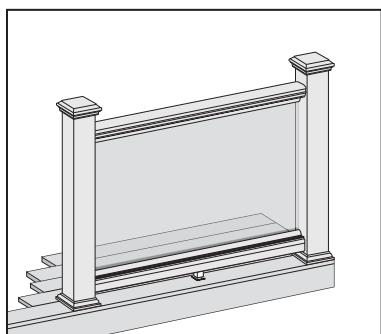

Glass Panel Style Railing

Follow instructions for Glass Panel assembly.
Cutting Post Sleeves is NOT required.

Trex Transcend™ Standard/Colonial/Classic & Glass Panel Installation

Note: Read all the instructions BEFORE installation.

If doing a CLASSIC STYLE railing (Over the Post) please refer to Step 1A in the Classic Section on page 42. This MUST be your first step.

Step 1 – Attaching the Posts, Skirts, and Post Sleeves

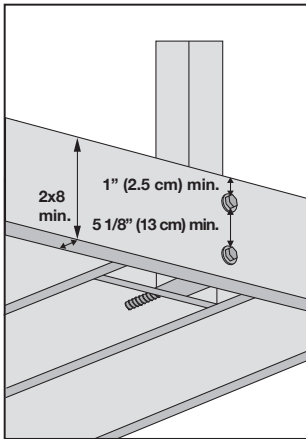

Post Installation

- Attach the Post using 1/2" (1.3 cm) carriage bolts.
- Minimum joist size is 2x8.
 - Top bolt must be 1" (2.5 cm) from top of joist.
 - Bottom bolt must be 5 1/8" (13 cm) from top bolt.

Note: blocking can be added for extra strength.

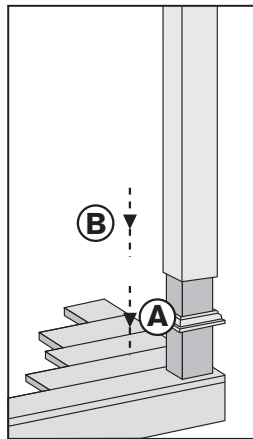

Post Skirt and Sleeve

- Slide a Post Skirt over Post.
- Slide a Post Sleeve over Post and inside the skirt.

Note: Shims can be used to plumb Post Sleeve.

Step 1 – Attaching the Railing Support Brackets (RSB's)

Without TrexExpress™ Template:

A. Mark 5 1/2" (14 cm) and 35 1/16" (89 cm) or 41 1/16" (104.3 cm) from the deck surface.

(or mark 5 1/2" (14 cm) and 41 1/16" (104.3 cm) from the deck surface for 42" (106.7 cm) nominal height.)

B. Attach RSB's in center of Post with top of the RSB aligned with mark (Bottom RSB flat side down, top RSB flat side up) and attach with the supplied wood screws.

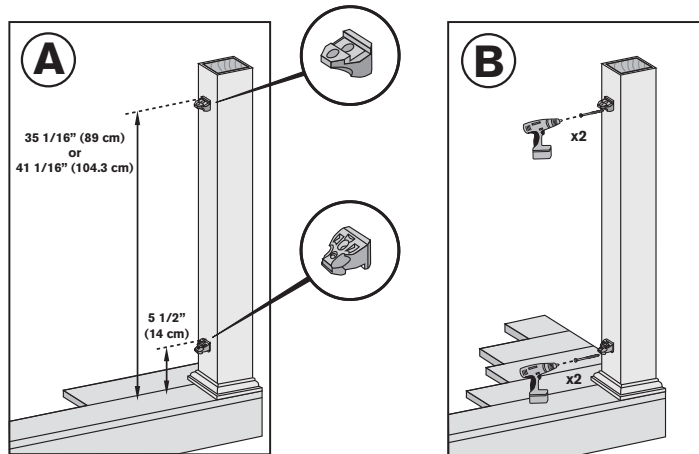

With TrexExpress™ Template:

- Place RSB's in template as shown.
- Slide template onto Post Skirt and hold in place with tape or rubber band.
- Attach RSB's using the supplied wood screws.
- Remove template.

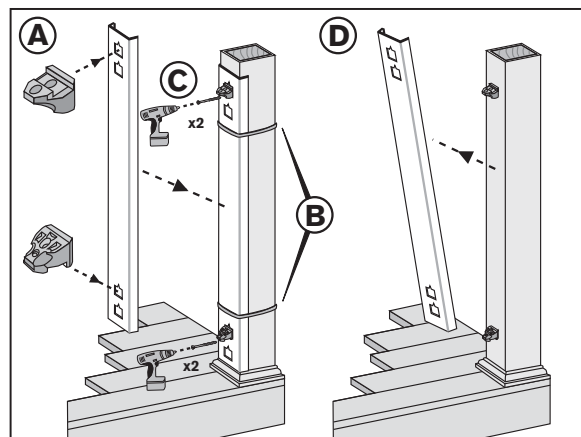

For 6x6 Plastic TrexExpress™ Template ONLY

- For 6x6 Sleeve TrexExpress™ Tool, 1/2" (1.3 cm) will need to be cut from the bottom (blue arrows up) of the tool before FIRST use.
- For 42" (106.7 cm) rail height the TOP RSB ONLY will need to be positioned up 6" (15 cm).

Step 3 – Attaching the Universal Rail and the Foot Block

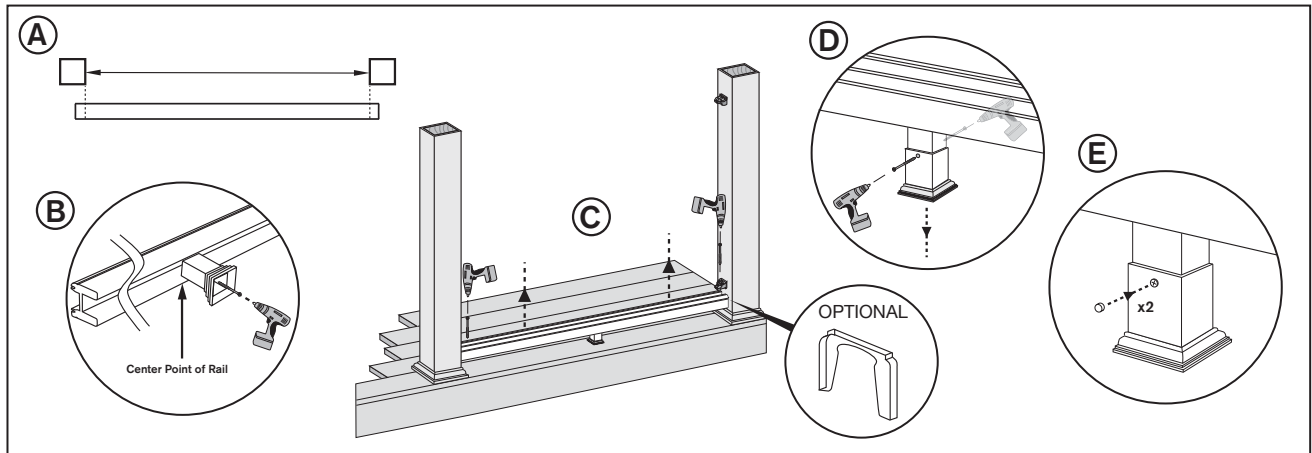

- A. Measure between the posts and cut rails to length. Note: Subtract 1/16" (0.16 cm) from each end if using optional rail gaskets.
- B. Center Foot Block in Universal Rail channel and attach. Wait to extend Foot Block.
- C. Lift Bottom Rail so RSB's are in channel and attach with self-tapping screws (provided). Place optional rail gaskets at each end of rail.
- D. Telescope Foot Block down and then screw through opposite sides.
- E. Place screw plugs on.

Step 4 – Placing the Baluster Spacers and Balusters

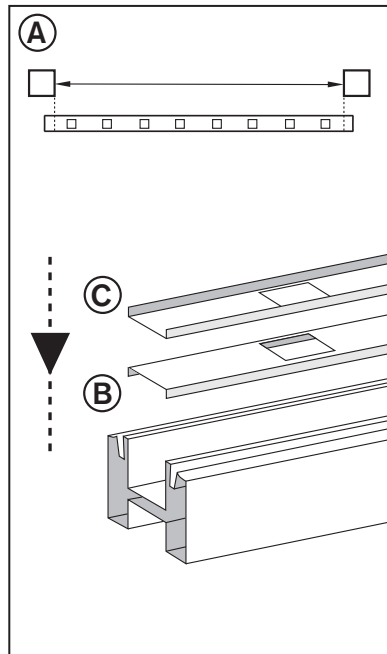

- A. Cut the Baluster Spacers to the same length as the rail, equally spaced so the holes line up.
- B. Snap Baluster Spacer into Bottom Rail.
- C. Place inverted Baluster Spacer on top of first Baluster Spacer.
- D. Place Balusters in Baluster Spacer holes.

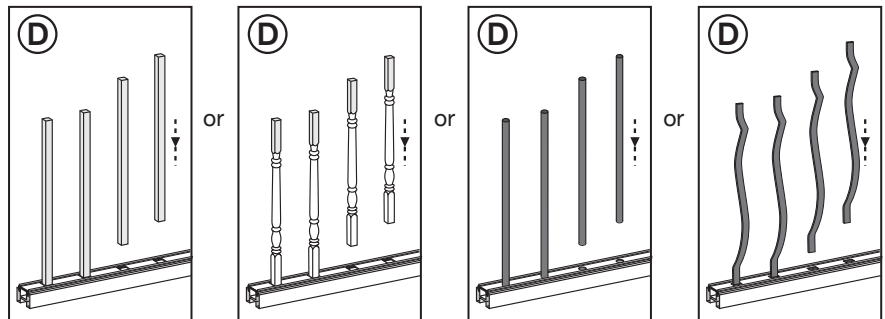

Standard Assembly

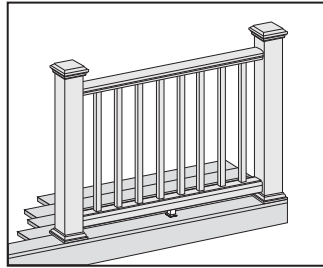

Step 5 – Attaching the Top Rail

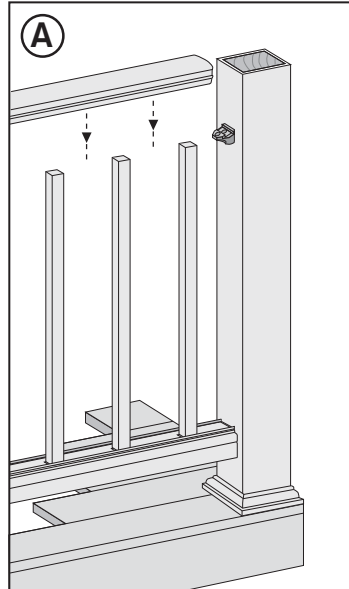

A. Place Top Rail on RSB's with Balusters in channel.

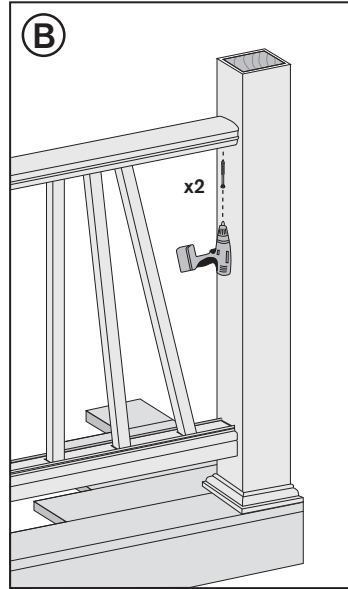

B. Attach Top Rail to RSB with 2 self-tapping screws (provided).

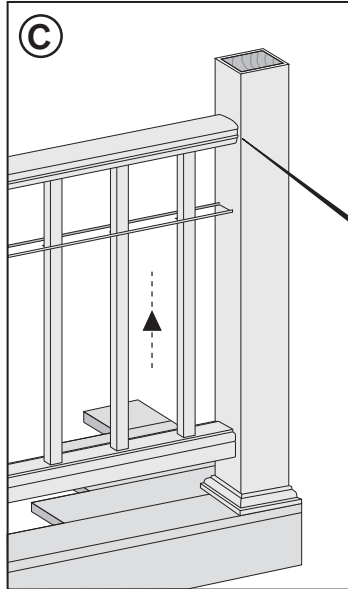

C. Slide Baluster Spacer up and snap into Top Rail.

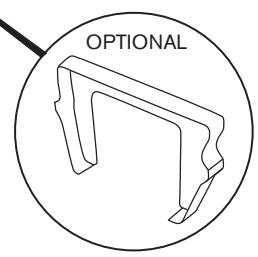

OPTIONAL
Place optional Top Rail gaskets on each end of rail.

Step 6 – Attaching the Post Caps

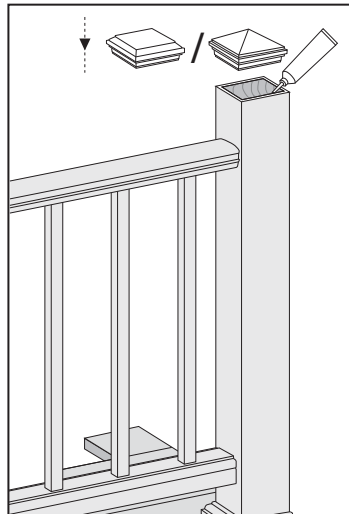

Secure Post Cap with silicone or PVC adhesive.
(Remove any excess adhesive.)

Classic Style Railing Assembly

Important: Only cut post & post sleeve if assembling the classic design!
Only for use with 4x4 post sleeve.

Step 1 – Cutting Post & Post Sleeve

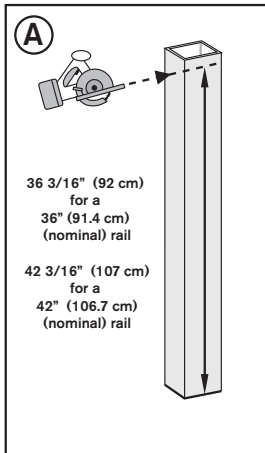

A. Cut Post to the length of the Post Sleeve + the height of the joist + thickness of deck board. From the deck surface, cut Sleeve to:

- 36 3/16" (92 cm) for 36" (91.4 cm) nom. height
- 42 3/16" (107 cm) for 42" (106.7 cm) nom. height

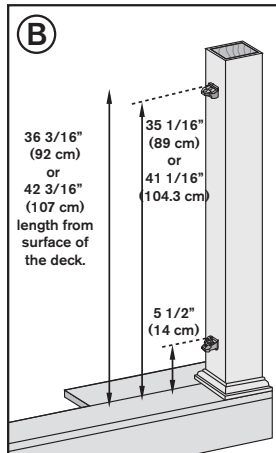

B. Measure and attach RSB's to post. **Note: Refer to Steps 2 thru 4 on previous pages for step-by-step instructions on attaching RSBs, Universal Rail, Foot Block, Baluster Spacers, and Balusters.**

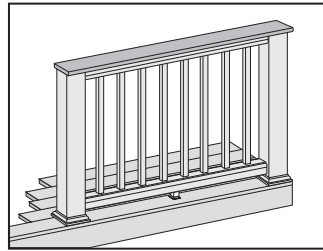

Step 5 – Attaching the inverted Universal Rail

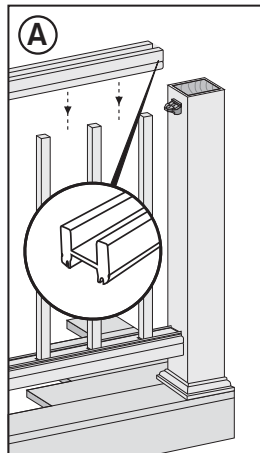

A. Place inverted Universal Rail onto RSB's with Balusters in channel.

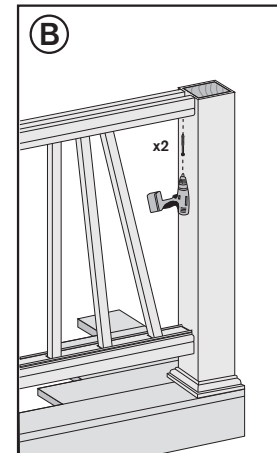

B. Attach Universal Rail to RSB with 2 self-tapping screws (provided).

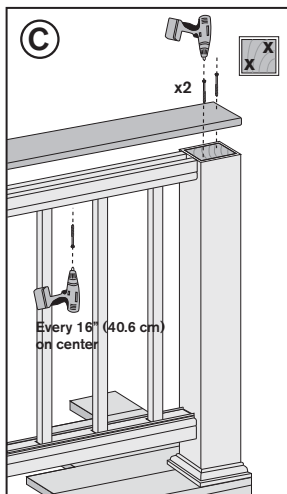

C. Place a deck board (do not use 5" Contours or Escapes) over the Universal Rail. Attach board with Trex recommended composite screws at a diagonal over each post. Attach board to Universal Rail with the provided 2" (5 cm) pan-head screws every 16" (40.6 cm) on center.

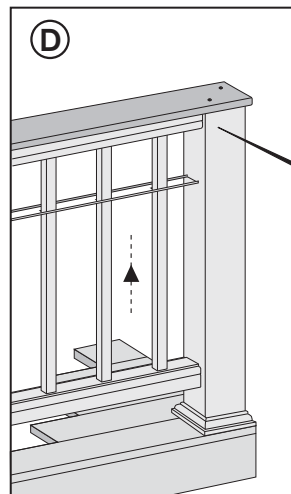

D. Slide Baluster Spacer up and snap into Universal Rail.

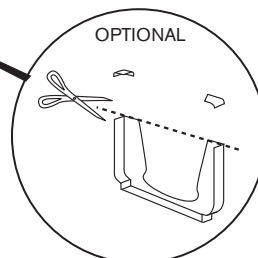

If necessary, cut tips off Rail Gasket prior to installation.

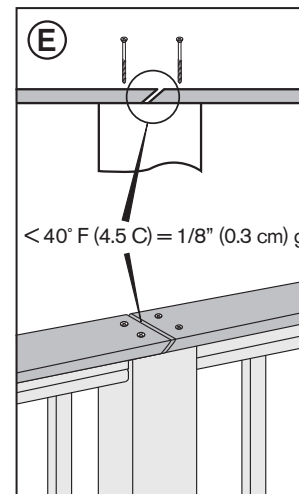

E. Use scarf cut for posts where two deck boards meet.
 * If installing below 40° F (4.5 C) leave 1/8" (0.3 cm) gap between deck boards.

Colonial Style Railing Assembly

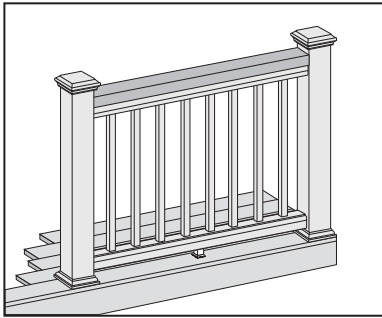

Note: Refer to Steps 1 thru 4 on previous pages for step-by-step instructions on attaching RSBs, Universal Rail, Foot Block, Baluster Spacers, and Balusters.

Step 5 – Attaching the inverted Universal Rail

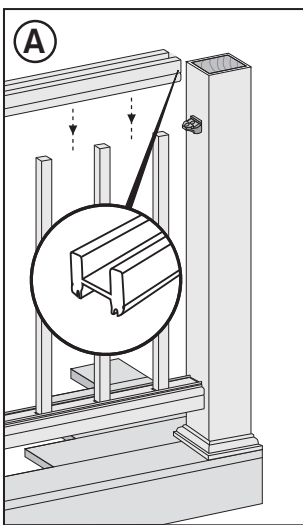

A. Place inverted Universal Rail onto RSB's with Balusters in channel.

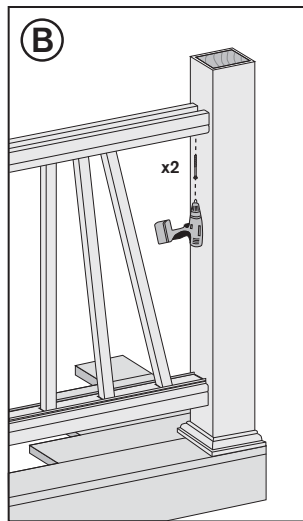

B. Attach Universal Rail with 2 self-tapping screws (provided).

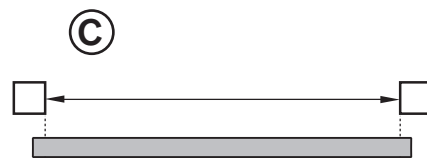

C. Measure between the posts and cut the 2x4 to this length.

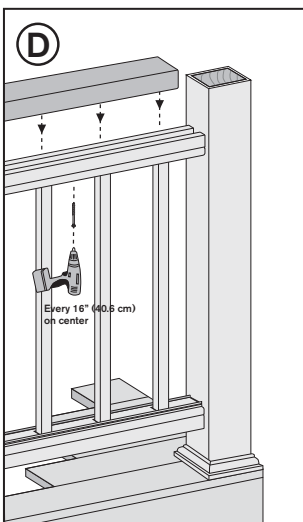

D. Place 2x4 on Universal Rail. Attach board to Universal Rail with the provided 2" (5 cm) pan-head screws every 16" (40.6 cm) on center.

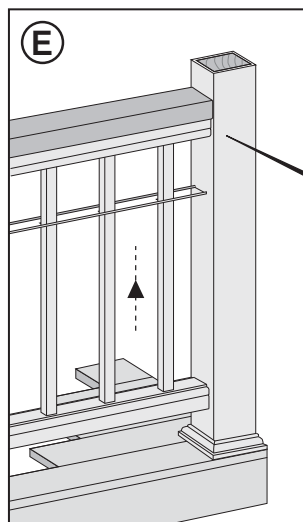

E. Slide Baluster Spacer up and snap into Universal Rail.

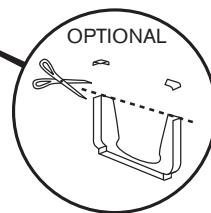

If necessary, cut tips off Rail Gasket prior to installation.

Step 6 – Attaching the Post Caps

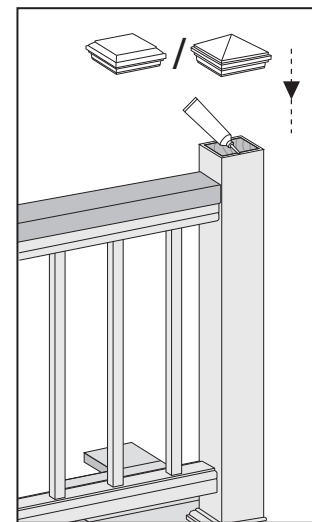

Secure Post Cap with silicone or PVC adhesive. (Remove any excess adhesive.)

Glass Panel Assembly

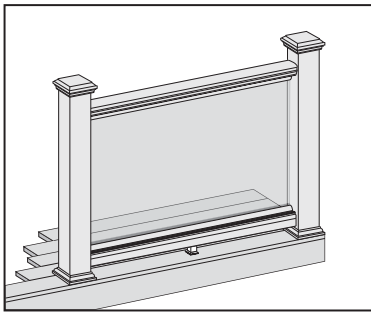

Note: Refer to Steps 1 thru 3 on previous pages for step-by-step instructions on attaching RSBs, Universal Rail, and Foot Block.

- ★ 1/4" (0.6 cm) Tempered Glass Panel will need to be purchased separately.
- ★ Only for use with maximum 6' (1.8 m) on center post spacing.

Dimensions for the tempered glass:

- for a 36" (91.4 cm) high rail: 1/4" (0.6 cm) x 30" (76 cm) x 62 1/2" (158.8 cm) (max.)
- for a 42" (106.7 cm) high rail: 1/4" (0.6 cm) x 36" (91.4 cm) x 62 1/2" (158.8 cm) (max.)

Step 5 – Attaching the Glass Panel & Top Rail

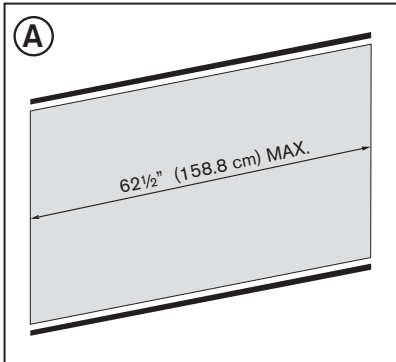

A. Apply Weather Stripping to Glass

Push the black edge trim onto the upper & lower edges of the glass. Be sure the edge trim runs the entire length of the glass. Extra trim can be cut off with a razor blade or sharp scissors.

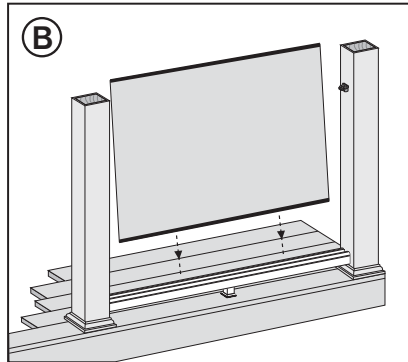

B. Position Glass

Place the glass with the weatherstripping into the lower rail channel. Center the panel between the two posts. (There should be approximately 2" (5 cm) between the panel and the posts.)

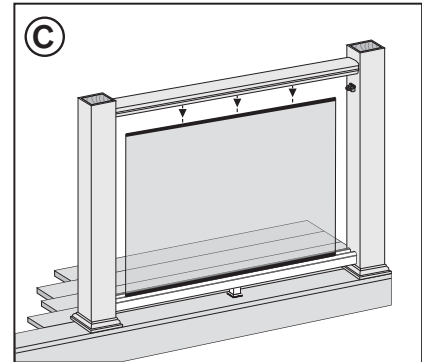

C. Attach Top Rail

Place the top rail over the brackets and glass panel. Secure the rail to the RSBs with 1 1/2" (3.8 cm) self-drilling screws, provided. *Avoid hitting glass while using drill.*

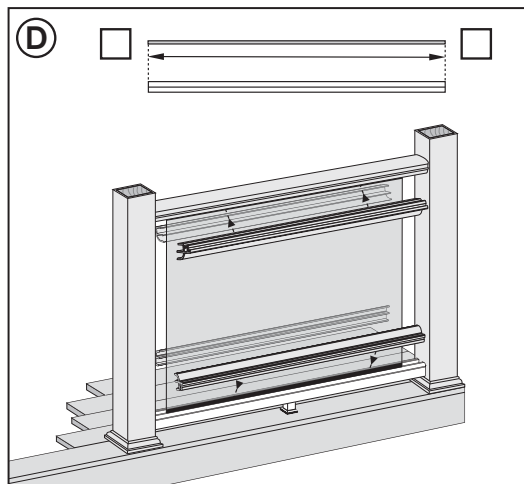

D. Cut & Attach Panel Support Moldings

Cut the four (4) panel support moldings (PSM) to the same length of the glass (62 1/2"/158.8 cm). Cut one at a time slowly to avoid chipping.

Push the PSM into the rails to complete snap connection. (The lower rail will have the PSM edge resting on top of rail, top rail PSM snaps flush into the rail.)

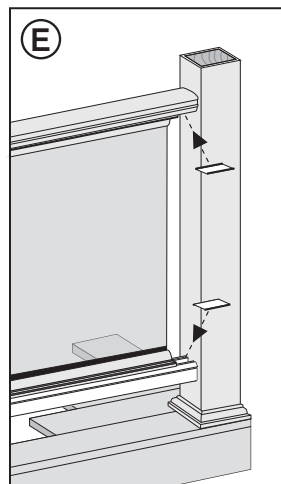

E. Hide the Brackets

Cut the Transcend Baluster Spacer into four lengths equal to the distance between the glass panel and the posts. Cut these slowly and one at a time to avoid chipping. Once these are all cut, snap them into the bottom and top rails to hide the brackets and create a seamless look.

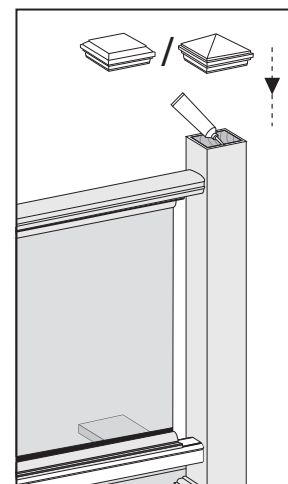

Secure Post Cap with silicone or PVC adhesive. *(Remove any excess adhesive.)*

Step 6 – Attaching the Post Caps

Trex Transcend™ Railing On An Angle Instructions

- Transcend brackets are designed for use up to a 45° install angle.
 - A. If angles are small (1° - 30°), either the 4x4 or 6x6 Post Sleeve will work well.
 - B. If angles are large (31° - 45°) and you want to install on flat side of Post Sleeve we recommend using the 6x6 Post Sleeve only.
 - C. If installing on a 45° angle and using the 4x4 Post Sleeve, the Transcend Birdsmouth must be used. Refer to the Birdsmouth Instructions for more details. Note this will install the railing on the corner of the post and not the flat side.
 - D. If installing on a 45° angle and using a 6x6 Post Sleeve, install brackets slightly off-center to allow for railing to fit properly (so it does not stick out past the post), and use 45° Transcend Gaskets.

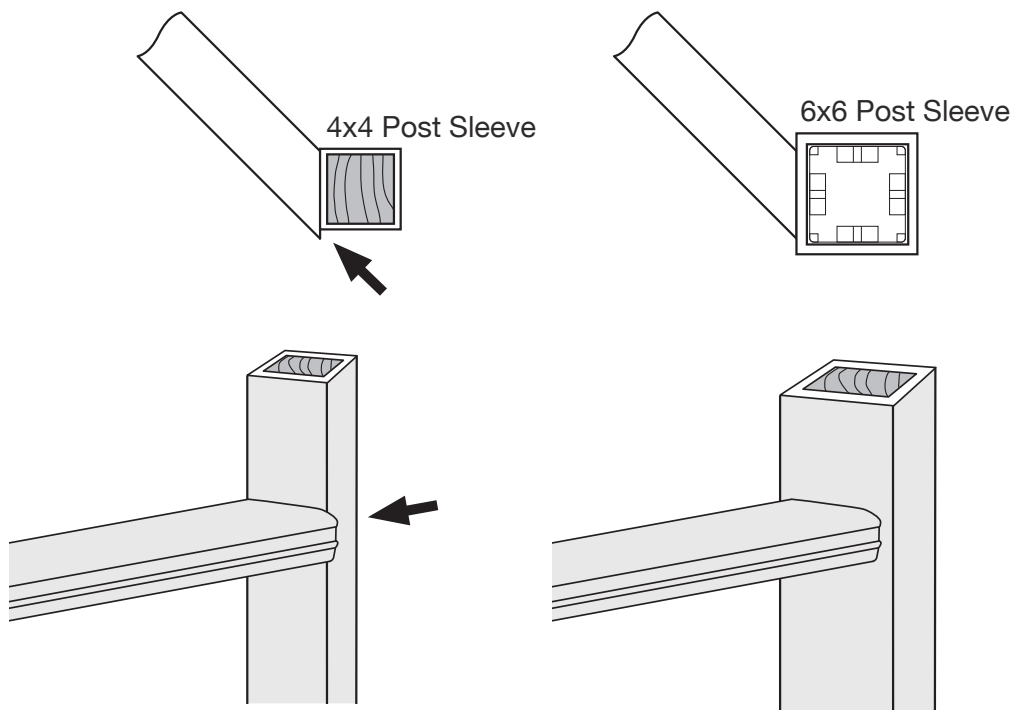

Trex Transcend™ Railing 45° Bird's Mouth Instructions

For use with 4x4 Post Sleeve ONLY.

Read all instructions prior to installation.

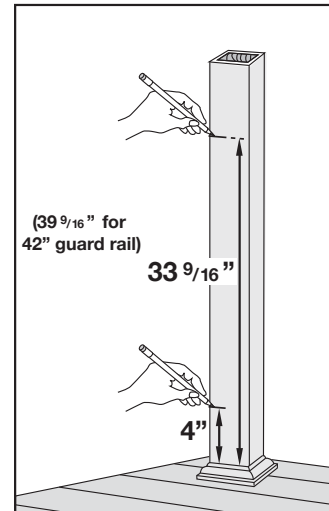
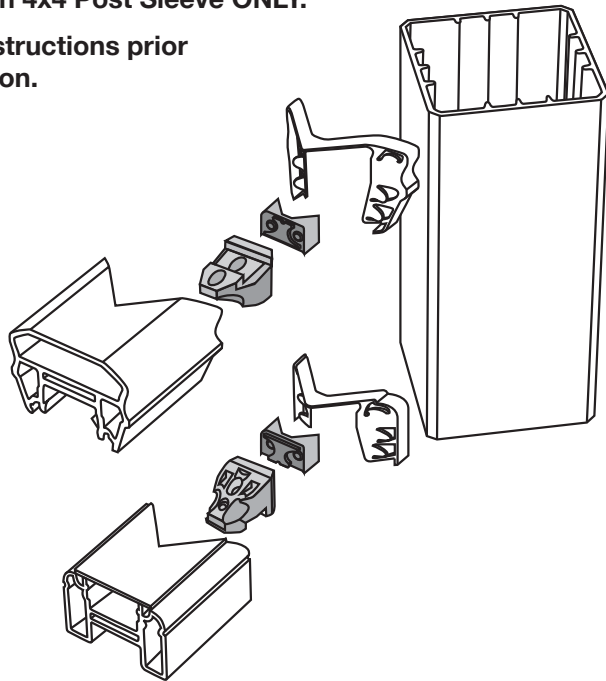

Step 1 - Mark the Posts

From the top of the Skirt (If not using Skirts add 1" to measurements) make a small line at 4" and 33 9/16" (39 9/16" for 42" guard rail) on the corner of the Post Sleeve.

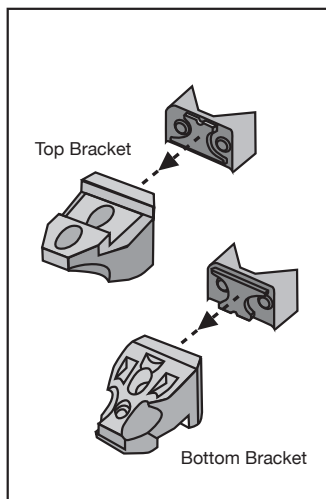

Step 2 - Attach Adapter

Snap the Adapter to the Railing Support Brackets (RSB's).

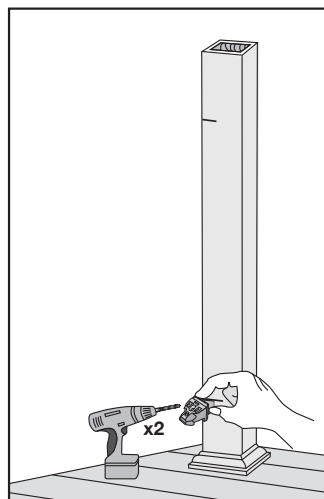

Step 3 - Pre-drill Bottom RSB

Place the top of the RSB with Adapter (flat side down) at the lower rail line and pre-drill the screw holes with a 1/8" drill bit.

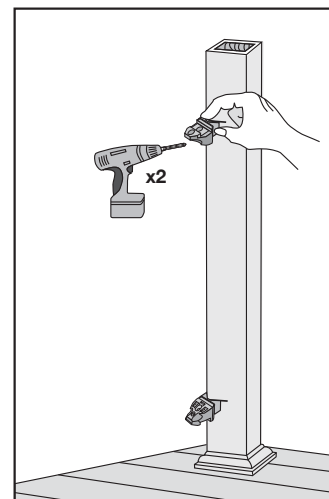

Step 4 - Pre-drill Top RSB

Place the top of the RSB with Adapter (flat side up) at the upper rail line and pre-drill the screw holes with a 1/8" drill bit.

Trex Transcend™ Railing 45° Bird's Mouth Instructions

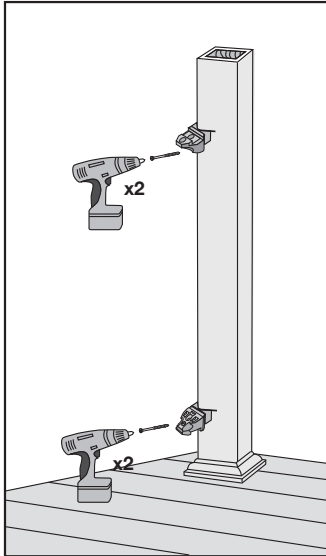

Step 5 - Attach the Top & Bottom RSB's

Attach the RSB's with Adapters to the post with the supplied wood screws.

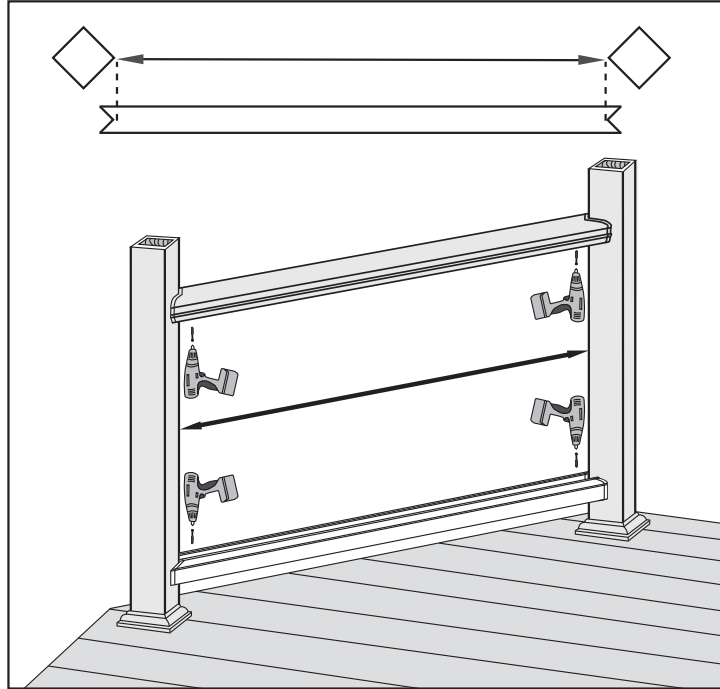

Step 6 - Measure & Cut the Rails

Measure from corner to corner between the posts. *Note: Subtract 1/16" from each end to accommodate rail gaskets.*

Cut the rails (the 45° Corner Template on the Assembly Tool can be used).

The center of the "V's" will be the distance from corner to corner of the post.

Attach rails with the provided self-tapping screws.

Using a Miter Box Saw to Cut the Rails

1. Place a 2x4 on edge behind the Rail to allow for complete cut.
2. Angle the blade to 45°.
3. Set the stop on the saw so the blade travels half the depth of the Rail - Several test cuts can be made on scrap material to accurately set the stop.
4. V cut both sides of the Rail.

Note: Transcend's Top and Universal Rail will require different stop settings.

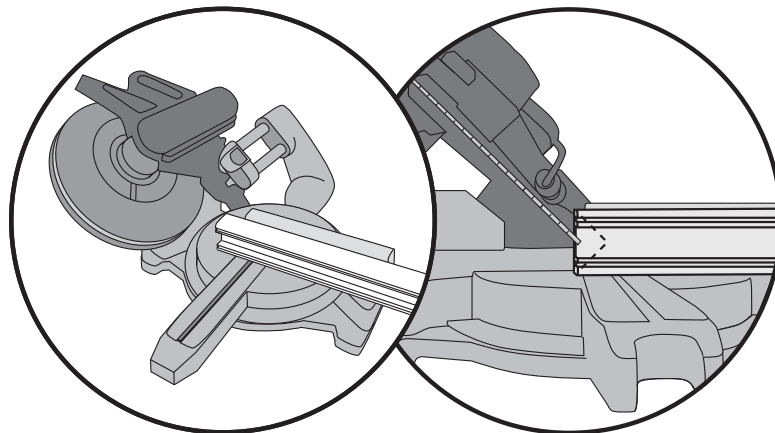

Trex Transcend™ Railing Foot Block Instructions

The installation of this Foot Block provides support for the universal rail while matching the refined look of Trex Transcend Railing®.

Read all instructions prior to installation.

1 Optional Foot Block Base Plate

Attach the Foot Block Base Plate directly to the deck board for additional support.

- Prior to installing the Railing Support Brackets (RSB's) to the post sleeves, cut universal rail to length.
- Temporarily slide post sleeve skirts up 3" or more.
- Center universal rail at each post sleeve. (see inset at right)
- At center point of universal rail, drill a 1/16" pilot hole through both the universal rail and 1/8" (min.) into the deck board below.
- Remove the universal rail and set aside.
- With a #10 x 3/4" Stainless Steel Screw (provided), attach the Foot Block Base Plate centered over the 1/16" pilot hole in the deck board. (see below)
- Foot Block will seat over Base Plate prior to installing Foot Block retaining screws.

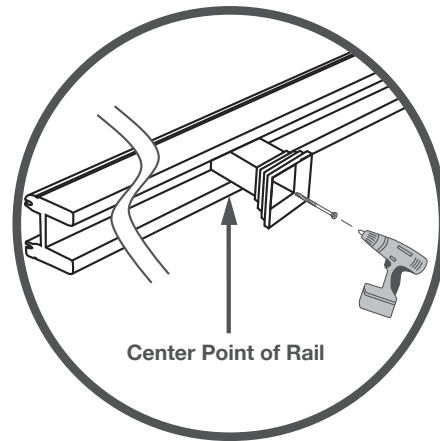
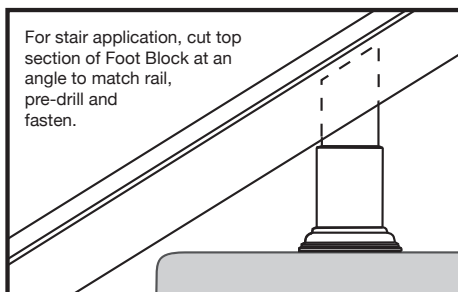
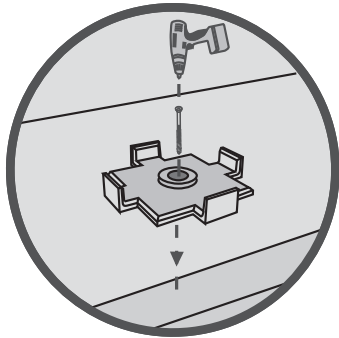
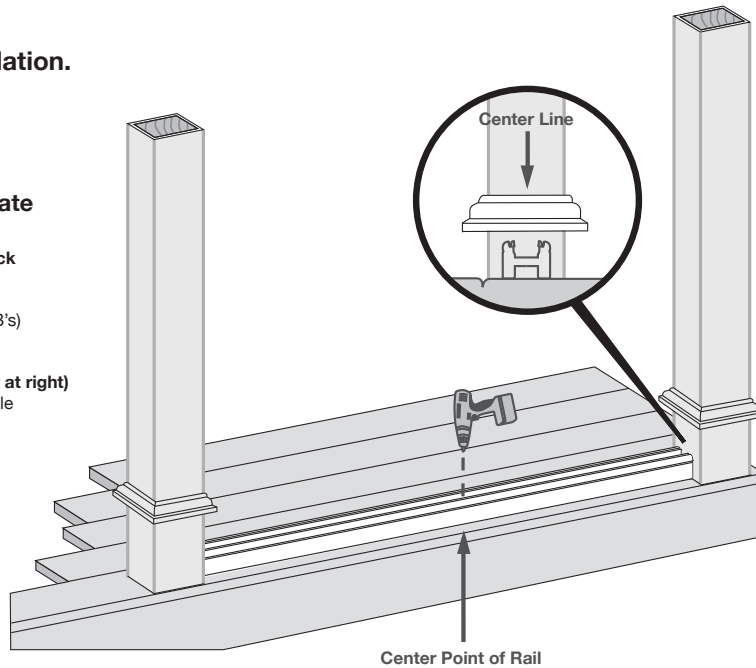

2

- Center the foot block in the universal rail channel at the mid-point of the universal rail span.
- With the foot block in its collapsed state, attach it to the universal rail using the supplied 2" screws, as shown above.

Trex Transcend™ Railing Foot Block Instructions

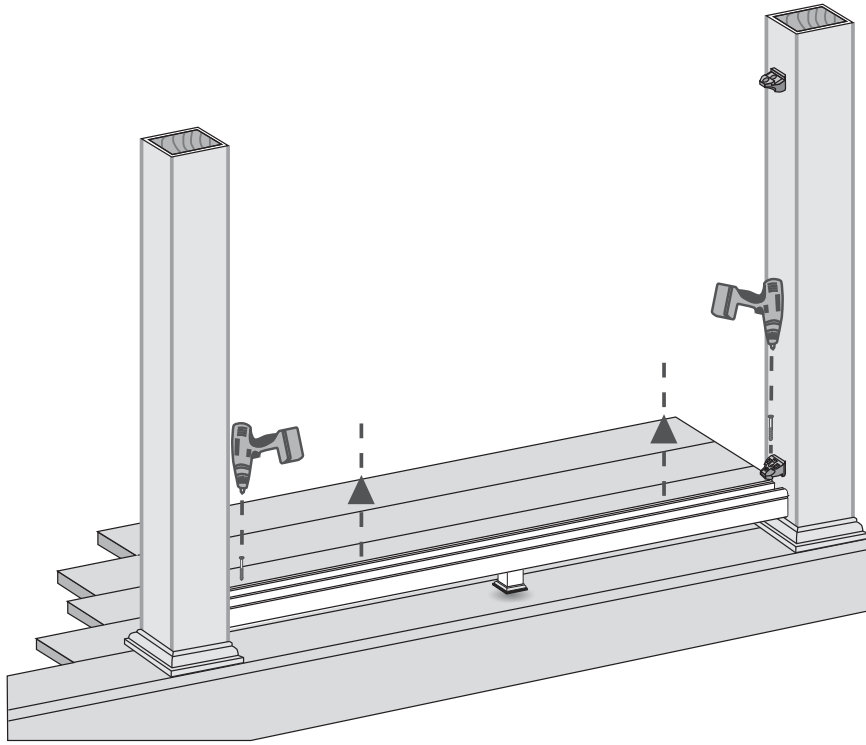

3

- a. Install the bottom rail.
- b. With bottom rail secured, pull down on the Foot Block until the base sits flush with the decking surface.

Note: If you have installed the optional Foot Block Base Plate, the Foot Block should seat over it as it telescopes

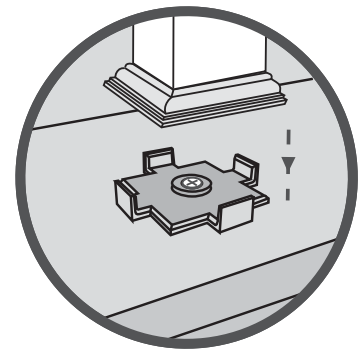

4

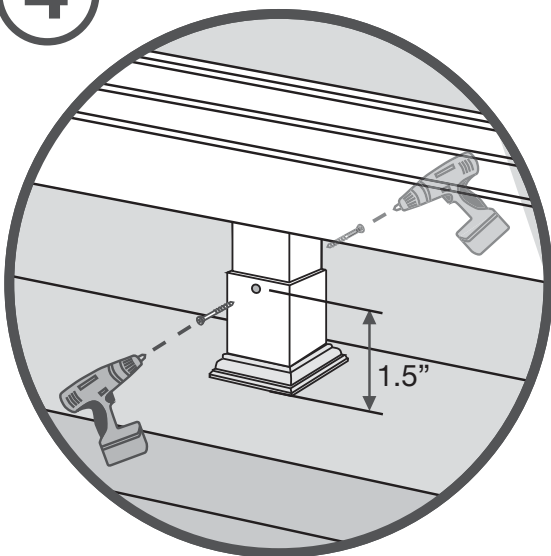

Install the supplied 3/4" retaining screws into the Foot Block on both the inside and the outside of the railing orientation, 1 1/2" from the bottom of Foot Block base, as shown above.

5

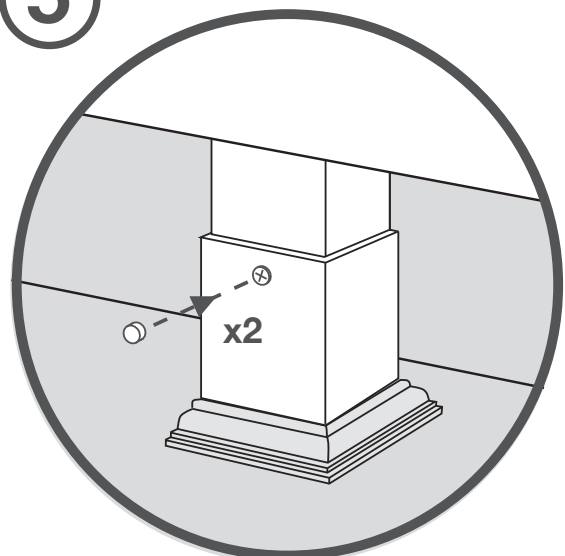

Install supplied snap caps onto retaining screws as shown above.

Trex Transcend™ Railing Stair Installation

1

STEP 1 - Install Posts/Sleeves/Skirts

- Install posts, sleeves, and skirts according to standard Transcend railing instructions.
- In most cases a post and post sleeve longer than 39" will be needed on the lower foot of the stair rail section to accommodate stair angle.
- Make sure both top and bottom posts for stairs are installed at the nose of each tread.

2

STEP 2 - Cutting Top and Bottom Stair Railing to Length

- Set railing along the nose of stair treads and marking a line at each intersection.
- Subtract 1/16" max from each end to allow clearance if using optional railing gaskets.

3

STEP 3 - Install Bottom Post RSB's

- Position pre-cut Bottom Rail between the posts.
- Slide Trex Express Railing Assembly Template into position, aligning the Bottom Rail outline on the Template with the end of the bottom rail. ***(see inset below)*.**
- Use rubber bands to hold Railing Assembly Template in place.
- Remove rail.
- Attach both RSB's to the bottom post, flat side up.
- Remove Railing Assembly Template.
- Take second RSB, turn upside down, and interlock into each bracket (see figure A).

** making sure to allow for clearance of stair treads of approximately 1"*

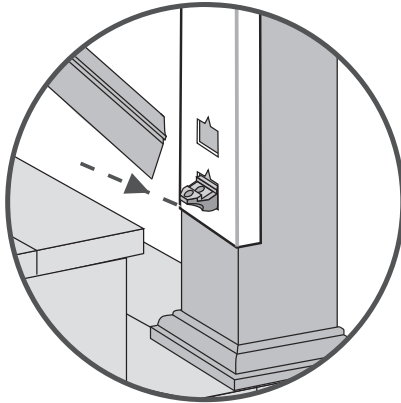

Transcend stair kits and gaskets work only with a stair slope at 32° - 37°

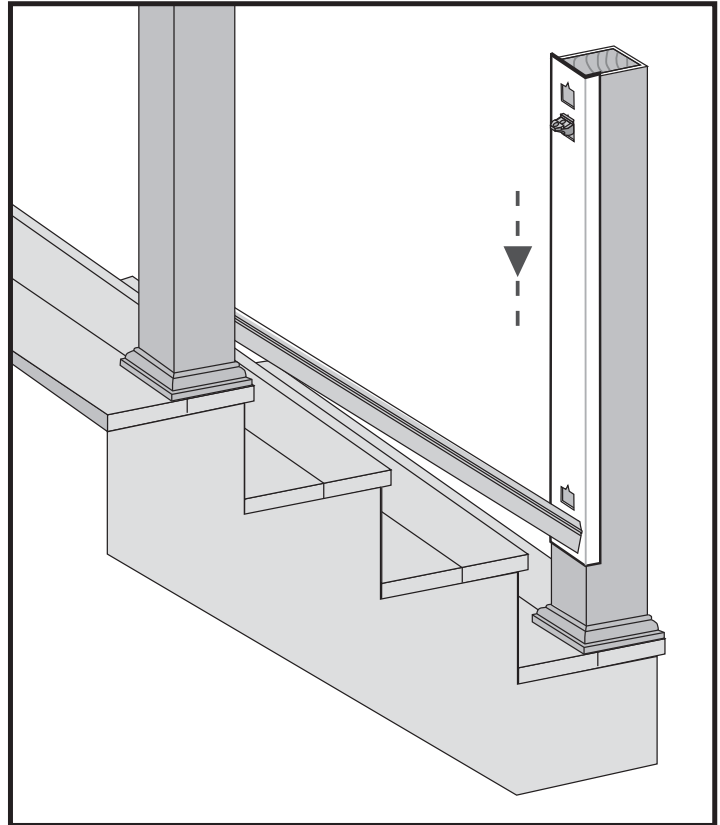

Trex Transcend™ Railing Stair Assembly

4

STEP 4 - Install Top Post RSB's

- a. Position pre-cut Bottom Rail between the posts.
- b. Slide Trex Express Railing Assembly Template into position, aligning the Bottom Rail outline on the Template with the end of the bottom rail. (Use the RSB on the bottom post for alignment.)
- d. Use rubber bands to hold Railing Assembly Template in place.
- e. Remove rail.
- f. Attach both RSB's to the top post, flat side up.
- g. Remove Railing Assembly Template.
- h. Take second RSB, turn upside down from current RSB configuration, and interlock into each bracket (see figure A).

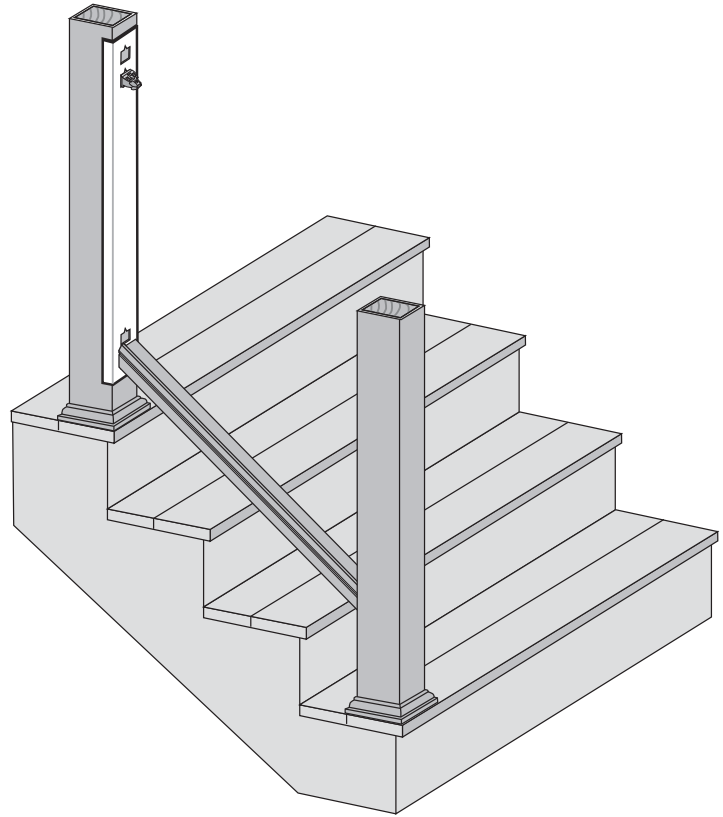

5

STEP 5 - Installing Footblock, Railings, Balusters

- a. Install footblock per footblock instructions. (This must be done before railing is installed.)
- b. Install railings, balusters, post caps per standard railing instructions.

Figure A



Trex Transcend™ Railing Top Rail Cap Instructions

For use with Standard Transcend style railing ONLY.

Step 1

Measure the distance between the posts.

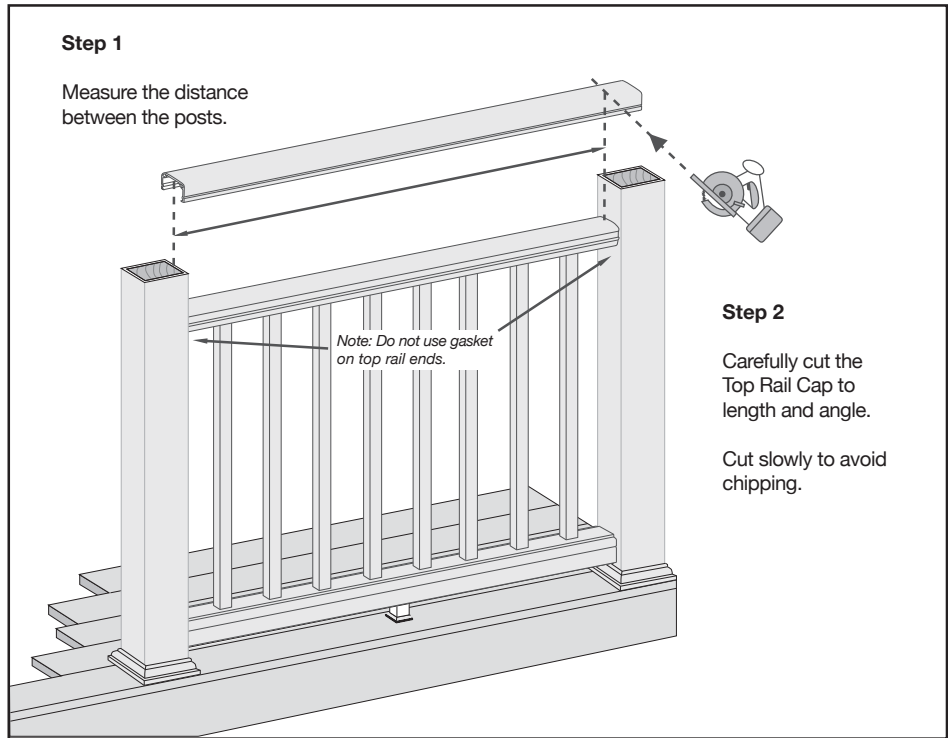

Note: Do not use gasket on top rail ends.

Step 2

Carefully cut the Top Rail Cap to length and angle.

Cut slowly to avoid chipping.

Step 3

Put adhesive on the Transcend Top Rail along the 2 "lines" on the top and right above the 2nd bump out from the top on either side.

Note: Please use Heavy Duty Construction adhesive.

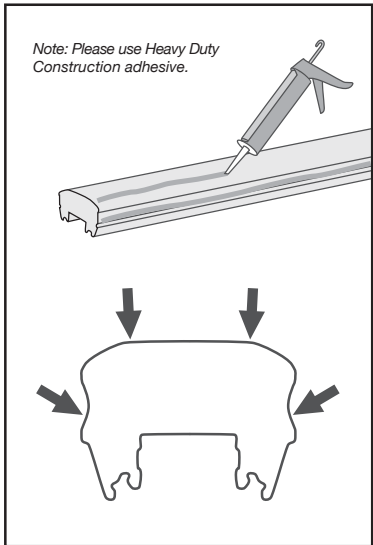
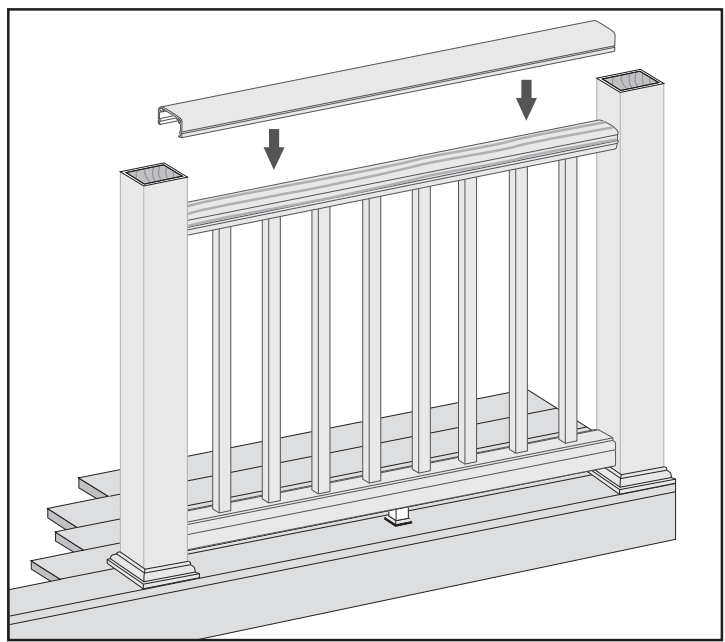
Step 4

Snap the Top Rail Cap down onto the Transcend Top Rail.

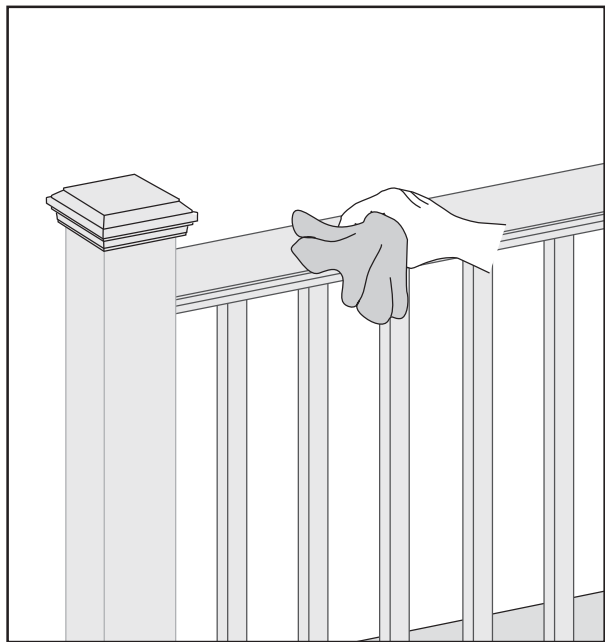

Step 5

Wipe away and clean off any excess adhesive from the Top Rail Cap and Transcend Top Rail.

Trex® ADA Hand Rail Instructions

Stair Application



Horizontal Application



ADA Hand Rail Guidelines

1. ADA Hand Rail can be installed in various design applications such as stairs, ramps and horizontal, and include options for straight and horizontal, and include options for straight and 90° wall returns, 90° corners, and adjustable angles. Choose which is best for your needs before installing.
2. Hand rail system top rail should be 34" - 39" above surface. However it is important to verify height requirements with local building code officials before installing as codes vary in different areas.*
3. Minimum clearance of 1½" shall be maintained between hand rail and any obstructions above or behind handrail.*
4. End Loop return at all landings must extend 12" past end of ramp or stair application.*
5. Slope of hand rail for ramp is not to exceed 1" rise over 12" run.*
6. Maximum recommended span between supports is 6' on center.
7. For ramps and stairs, railing along with end loops and/or post returns must be cut to the proper angle using a miter saw to ensure proper fit.

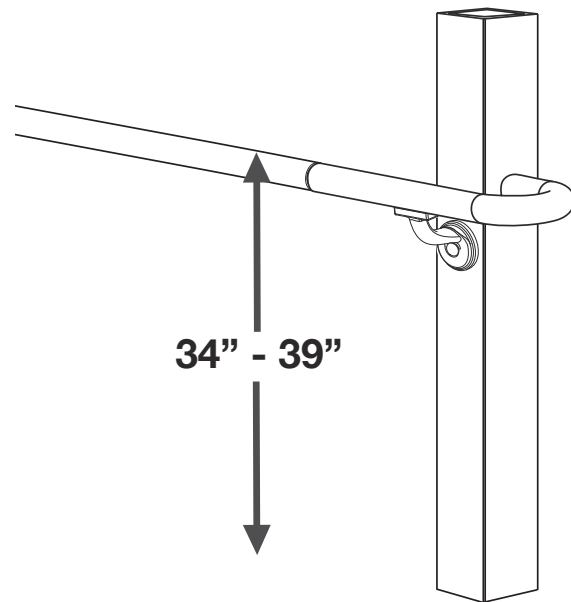

Trex® ADA Hand Rail Instructions

90° Wall Return

Cut the aluminum and PVC tube to proper length.

- A. Apply adhesive to all metal contact surfaces.
- B. Ensure flange cover is placed over PVC rail prior to assembly.
- C. Slide straight joiner into wall return and aluminum rail support.
- D. Attach mounting flange to desired surface. Snap flange cover into place.

Note: Hardware not included.

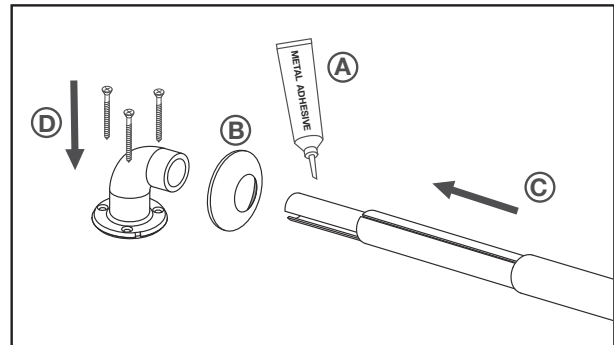

Straight Wall Return

Cut the aluminum and PVC tube to proper length.

- A. Apply adhesive to all metal contact surfaces.
- B. Ensure flange cover is placed over PVC rail prior to assembly.
- C. Insert straight wall return into aluminum rail support.
- D. Attach mounting flange to desired surface. Snap flange cover into place.

Note: Hardware not included.

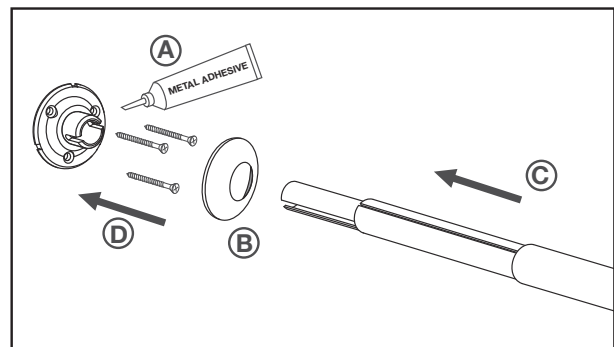

Hand Rail Bracket

- A. Predrill hole using 1/4" bit and attach bracket to mounting surface using an appropriate connector (a 3/8" lag bolt at least 2" long should be used when mounting to a wood surface). *Note: lag bolt is not included.*
- B. Place rail at appropriate location on bracket.
- C. Pre-drill two holes in rail with an 11/64" bit at appropriate location and attach with screws provided.
- D. Snap bolt cover into place.
- E. Using PVC adhesive, attach hand rail end cap (sold separately) to unfinished end of rail.

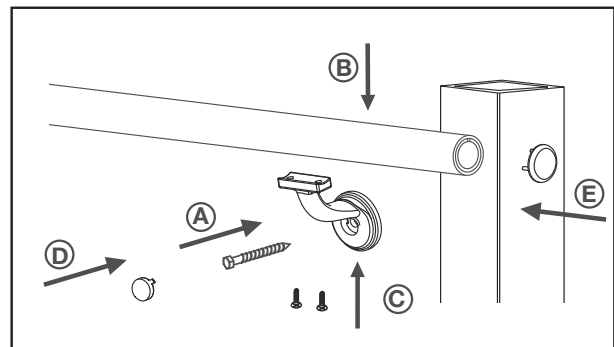

90° Corner

Cut the aluminum and PVC tube to proper length.

- A. Apply adhesive to all metal contact surfaces.
- B. Slide straight joiner into each side of corner and aluminum rail supports.

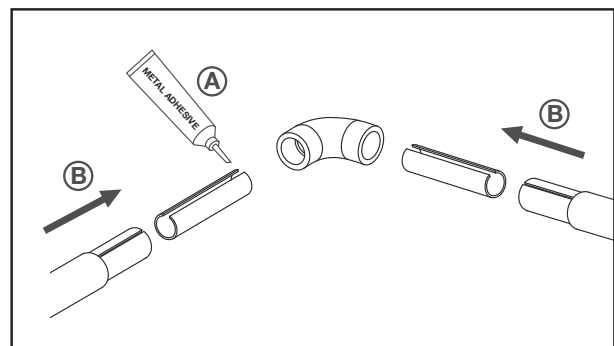

Note: A PVC adhesive may be used to ensure a tight seam on the exterior tube. Ensure adhesive cures per manufacturer's instructions.

Trex® ADA Hand Rail Instructions

End Loop - 18"x12"x18" Horizontal

- A. Apply adhesive to all metal contact surfaces. Slide straight joiner into end loop and aluminum rail support.
- B. Predrill holes using 1/4" bit and attach top bracket to mounting surface using an appropriate connector (a 3/8" lag bolt at least 2" long should be used when mounting to a wood surface).
- C. Attach bottom bracket in the same manner.
- D. Place end loop in appropriate location on bracket.
- E. Predrill 4 holes in end loop with an 11/64" bit at appropriate location and attach with screws provided.
- F. Snap bolt covers into place.
- G. Using PVC adhesive, attach hand rail end cap (sold separately) to unfinished end of rail.

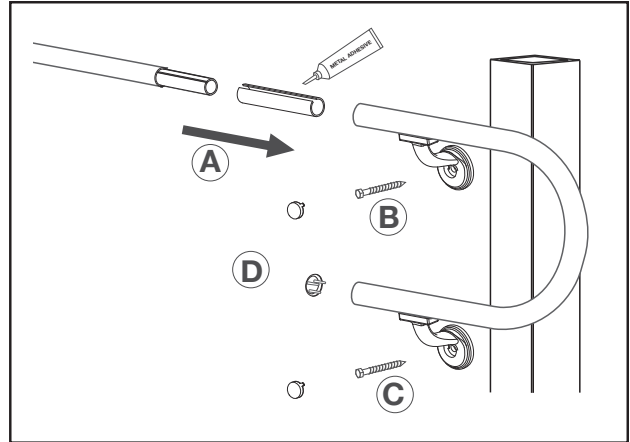

End Loop - 18"x12"x18" Angled

Rail and End Loop must be cut to appropriate angle before installing.

- A. Apply adhesive to all metal contact surfaces. Slide adjustable joiner into end loop and aluminum rail support. Make sure adjustable joiner is plumb.
- B. Predrill holes using 1/4" bit and attach top bracket to mounting surface using an appropriate connector (a 3/8" lag bolt at least 2" long should be used when mounting to a wood surface).
- C. Attach bottom bracket in the same manner.
- D. Place end loop in appropriate location on bracket.
- E. Predrill 4 holes in end loop with an 11/64" bit at appropriate location and attach with screws provided.
- F. Snap bolt covers into place.
- G. Using PVC adhesive, attach hand rail end cap (sold separately) to unfinished end of rail.

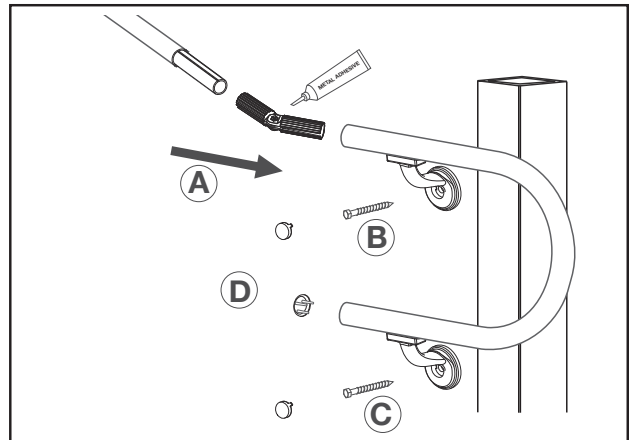

Post Return - Horizontal

- A. Apply adhesive to all metal contact surfaces. Slide straight joiner into post return and aluminum rail support.
- B. Predrill holes using 1/4" bit and attach bracket to mounting surface using an appropriate connector (a 3/8" lag bolt at least 2" long should be used when mounting to a wood surface).
- C. Place post return at appropriate location on bracket.
- D. Predrill 2 holes in post return with an 11/64" bit at appropriate location and attach with screws provided.
- E. Snap bolt covers into place.

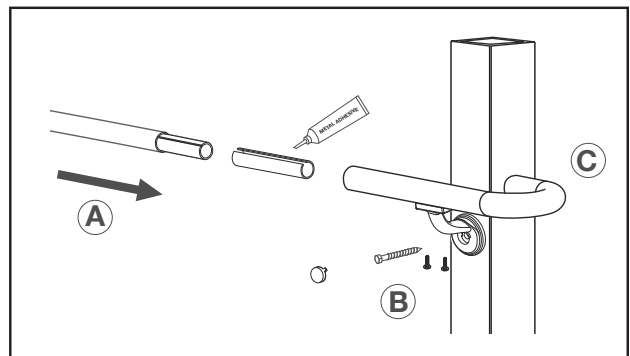

Note: A PVC adhesive may be used to ensure a tight seam on the exterior tube. Ensure adhesive cures per manufacturer's instructions.

Trex® ADA Hand Rail Instructions

Post Return - Angled

- A. Apply adhesive to all metal contact surfaces. Slide adjustable joiner into post return and aluminum rail support. Make sure adjustable joiner is plumb.
- B. Pre-drill holes using 1/4" bit and attach bracket to mounting surface using an appropriate connector (a 3/8" lag bolt at least 2" long should be used when mounting to a wood surface).
- C. Place post return at appropriate location on bracket.
- D. Pre-drill 2 holes in post return with an 11/64" bit at appropriate location and attach with screws provided.
- E. Snap bolt cover into place.

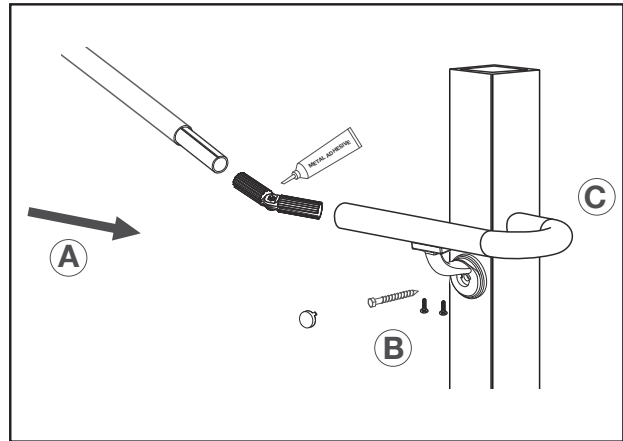

Straight Joiner

- A. Apply adhesive to all metal contact surfaces.
- B. Optional: Position joint ring between rail sections.
- C. Slide joiner into both aluminum rail supports until the joint is tight.

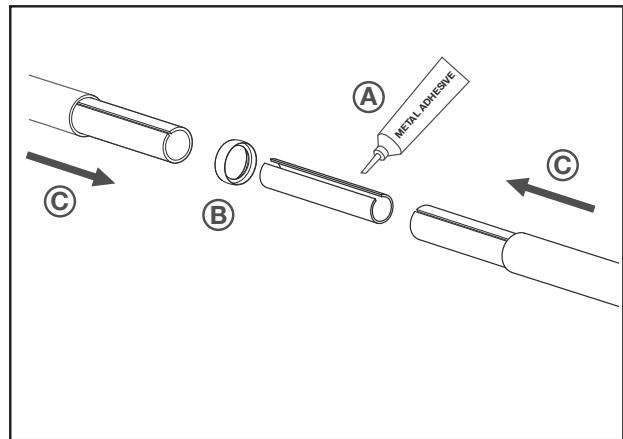

Angled Corner

- A. Cut the aluminum and PVC tube to proper length at desired angle.
- B. Apply adhesive to all metal contact surfaces.
- C. Slide rails together until the adjustable joint is tight.

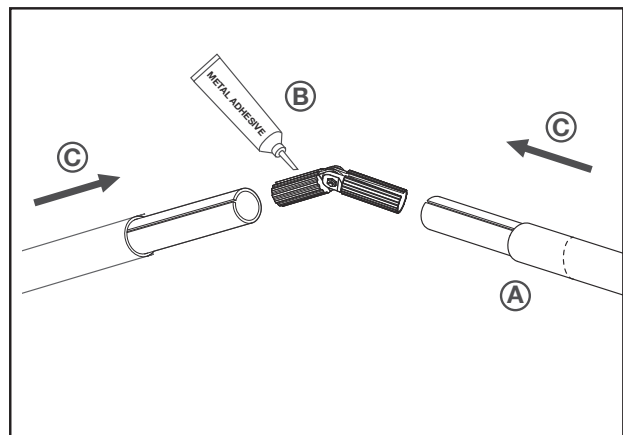

Note: A PVC adhesive may be used to ensure a tight seam on the exterior tube. Ensure adhesive cures per manufacturer's instructions.

Trex Transcend™ Care and Cleaning Guide

All exterior building materials require cleaning. Periodic cleaning of Trex Transcend™ decking and railing will maintain the beauty of the deck. Removing pollen and other debris from the deck surface, periodically, will help to reduce mold growth on the biofilm.

Solution	
General Dirt and Debris	The affected area should be sprayed off with a hose to remove surface debris. Use warm soapy water and a soft bristle brush to remove dirt and debris from the embossing pattern
Chalk Lines	High permanence chalk lines may discolor the surface. Use only Irwin Strait-line dust off marking chalk (purple) available at irwin.com
Tannins Due to Debris	Remove all debris from deck using a hose or broom. Once the deck surface is dry apply a “deck brightener” to the deck as directed by the manufacturer. Deck brighteners contain Oxalic acid which will remove tannins.
Ice & Snow	A plastic shovel may be used to remove snow from the deck. Use Calcium chloride or rock salt to melt the snow and ice from the deck surface.
Oil/Grease/Food	All food spills should be removed as soon as possible. The surface must be cleaned within seven days to maintain the stain warranty. To remove, spray off with a hose and use warm, soapy water and a soft bristle brush to remove spills from embossing pattern.
Mold and Mildew	If debris such as pollen and dirt is allowed to remain on the deck surface, mold can feed on the biofilm. Using a hose and warm soapy water with a soft bristle brush is recommended to remove the food source and mold.
Pressure Washer	A 1500psi power washer may be used on Transcend™ shell surface to remove dirt and debris. Use a fan tip at least 4” away from the shell when using a power washer.
Transcend™ Railing	Never use Acetone or other solvents on Trex Transcend™ railing to maintain the beauty of the surface.

Trex® Decking & Railing General Care and Cleaning Guide (Composite & PVC)

All exterior building materials require cleaning. Trex recommends basic cleaning with soap and hot water or a commercially available deck cleaner twice a year. This will help maintain the beauty of Trex decking, fencing, railing, and trim.

Solution	
Dirt and Debris	Clean deck to remove dirt and debris. Soap and hot water is all that is needed.
Chalk Markings	Most colored chalk lines are permanent. For Trex use either baby powder or Irwin Strait-line dust off marking chalk available at: http://www.irwin.com/irwin/consumer/jhtml/detail.jhtml?prodId=IrwinProd210003
Visible Printing	The printing on the side of Trex decking boards are required by building codes. With careful installation, most printings can be hidden. Visible printings can be lightened with acetone.
Water Spots, Leaf Staining & Wood Tannins	Tannin leaching occurs in Trex and all wood-based products naturally. Allow for at least 12 weeks of normal weathering. This process may be hastened through the use of a product containing oxalic or phosphoric acid, commonly known as Deck Brightener. *
Ice & Snow	Calcium chloride or rock salt, available in many home centers, will melt ice on Trex decking. Rinse off when first practical. Use caution when removing snow or ice with a snow shovel, and never use a metal snow shovel on a Trex deck. A shovel may scratch the deck, which is not covered under warranty.
Scuffs & Abrasions	Scuffs and abrasions can fade or disappear naturally after 12 - 16 weeks of weathering. This can be accelerated with a product containing oxalic or phosphoric acid, also known as Deck Brightener. *
Rust Stains, Ground-In Dirt & Grime & Pigment staining	Use a cleaning product containing oxalic or phosphoric acid base, also known as Deck Brightener to lighten or remove the rust or dirt. Product may need to sit on stain 10 - 15 minutes before rinsing. *
Oil & Grease Stains	Rinse the stain with hot water as soon as possible. Use Pour-N-Restore www.pour-n-restore.com as directed for any remaining stain (test in a small area first as this may remove some of the colorant from the decking surface).
Mold & Mildew	Semi-annual (spring and fall) cleaning of your deck is important to prevent the buildup of pollen and other debris that can support the growth of mold. Use conventional deck washes or cleaners that contain sodium hypochlorite (bleach) and detergent (refer to Mold Technical Bulletin on www.trex.com for specific recommendations). * Note: Trex Escapes can be effectively cleaned by using a hose and warm, soapy water with a soft bristle brush.
Pressure Washer	Trex Company does not recommend the use of a pressure washer. The use of a pressure washer with a greater than 1,500 PSI and/or applied closer than 12" from the deck surface could damage the decking surface and result in a loss of warranty coverage.
Sanding	Trex Company does not recommend sanding. Sanding will change the appearance of the surface of Trex® material and will void the warranty.
Disposal	Trex Decking and Railing products should be disposed with normal construction debris or household waste. Do not burn Trex products.

*Use of products containing bleach or acid will lighten the surface of Trex. Use in an inconspicuous area to determine if lightening is aesthetically pleasing to you. Neither product will affect the structural integrity of Trex.

Note: Trex does not recommend the placement of rubber or vinyl materials such as those found in grill mats, rubber-backed welcome mats, vinyl or PVC potted containers, etc., on the surface of Trex Escapes® for extended periods of time. This is due to the presence of additives in the rubber and PVC products that have a tendency to migrate from these materials to Trex Escapes over time, resulting in discoloration of the surface.

Mold Technical Bulletin

Mold is a lower form of plant life that can settle and grow on any surface, including Trex® decking. Mildew is a form of mold that grows on damp surfaces.

Mold spores are similar to seeds, but cannot be seen until colonies form. Air currents, insects, animals and water transport the spores easily. Due to mold's adaptability and large number of species, it is very hard to control and impossible to totally eliminate. Mold will not affect the structural performance of Trex decking.

In order to form visible colonies, mold needs food, moisture, and temperatures between 40 and 90° F. Trex decking is not a food source for mold, but can collect food in the form of dirt and debris such as the overflow from flowerpots and gutters. Trex decking can also supply moisture if the gaps between deck boards are too small or clogged. Refer to Trex decking Usage Guidelines for gapping instructions.

How to remove Mold from Trex® Composite & PVC Decking

All exterior building materials require cleaning. Trex is no exception. Periodic cleaning of Trex decking will remove dirt and pollen that can feed mold. If mold colonies appear, clean the deck with a commercial deck wash containing a detergent and sodium hypochlorite, commonly known as bleach. This chemical will remove the mold, but please be aware it will also lighten the wood on the surface. In some cases it will require several treatments with the deck wash to completely remove all mold colonies. Even if the spots are no longer visible, there may still be mold spores on the surface that could re-grow, so periodic cleaning is important.

The following brands of deck cleaners have been found to be effective in removing mold from Trex decking:

- Olympic® Premium Deck Cleaner*
- Expert Chemical™**Composite Deck Cleaner & Enhancer (expertchemicalinc.com)

Always apply these products to a dry deck. Applying to a wet deck will significantly reduce the effectiveness of the cleaner. NEVER mix any other cleaners (ammonia, phosphoric acid, etc.) with bleach.

- For a non-chlorine based alternative UltraMean®*** can be used, but will require scrubbing with a soft brush immediately after application.

Should you prefer an Eco-friendly product, the following will reduce the appearance of mold on the decking surface:

- Corte-Clean® ***Composite Deck Cleaner (corteclean.com)

Mold spreads easily and may return in some environments despite proper cleaning and preventative measures. Mold does not damage Trex and will cause no structural harm if allowed to propagate.

How to remove Mold from Trex Transcend™ Decking

If debris such as pollen and dirt is allowed to remain on the deck surface, mold can feed on the biofilm. Using a hose and warm soapy water with a soft bristle brush is recommended to remove the food source and mold.

* Olympic® is a registered trademark of PPG Architectural Finishes, Inc.

** Expert Chemical™ is a trademark of Expert Chemical Inc.

*** Corte-Clean® is a registered trademark of Corte LLC.

**** UltraMean® is a registered trademark of Rhino Hide®

Limited Residential Warranty

Trex Company, Inc. (hereinafter “Trex”) warrants to the original residential purchaser (“Purchaser”) that, for a period of twenty-five (25) years from the date of original purchase, under normal residential use and service conditions, Trex® products shall be free from material defects in workmanship and materials, and shall not split, splinter, rot or suffer structural damage from termites or fungal decay. If a defect occurs within the warranty period, Purchaser shall notify Trex in writing and, upon confirmation by an authorized Trex representative of the defect, Trex’s sole responsibility shall be, at its option, to either replace the defective item or refund the portion of the purchase price paid by Purchaser for such defective item (not including the cost of its initial installation).

For purposes of this warranty, a “residential purchaser” shall refer to an individual residential homeowner.

This warranty shall not cover and Trex shall not be responsible for costs and expenses incurred with respect to the removal of defective Trex products or the installation of replacement materials, including but not limited to labor and freight.

This warranty may be transferred one (1) time, within the five (5) year period beginning from the date of original purchase by the Purchaser, to a subsequent buyer of the property upon which the Trex products were originally installed.

Notwithstanding the foregoing, (a) with respect to hardware for the Trex Surroundings® gate (gate frame, hinges and screws), the term of the warranty shall be five (5) years from the date of original purchase, and (b) with respect to Trex Decorative Balusters, the period of the limited warranty herein covering the paint coating shall be ten (10) years, and shall be prorated in the following manner: 100% replacement for the first 5 years; and 50% replacement for the next 5 years.

To make a claim under this limited warranty, Purchaser, or the transferee, shall send to Trex, within the warranty period referred to above, a description of the claimed defect and proof of purchase, to the following address:

Trex Company, Inc.
Customer Relations
160 Exeter Drive
Winchester, VA 22603-8605

Trex does not warrant against and is not responsible for, and no implied warranty shall be deemed to cover, any condition attributable to: (1) improper installation of Trex products and/or failure to abide by Trex’s installation guidelines, including but not limited to improper gapping; (2) use of Trex products beyond normal residential use, or in an application not recommended by Trex’s guidelines and local building codes; (3) movement, distortion, collapse or settling of the ground or the supporting structure on which Trex products are installed; (4) any act of God (such as flooding, hurricane, earthquake, lightning, etc.), environmental condition (such as air pollution, mold, mildew, etc.), staining from foreign substances (such as dirt, grease, oil, etc.), or normal weathering (defined as exposure to sunlight, weather and atmosphere which will cause any colored surface to gradually fade, chalk, or accumulate dirt or stains); (5) variations or changes in color of Trex products; (6) improper handling, storage, abuse or neglect of Trex products by Purchaser, the transferee or third parties; or (7) ordinary wear and tear.

No person or entity is authorized by Trex to make and Trex shall not be bound by any statement or representation as to the quality or performance of Trex products other than as contained in this warranty. This warranty may not be altered or amended except in a written instrument signed by Trex and Purchaser.

UNDER NO CIRCUMSTANCES WILL TREX BE LIABLE FOR SPECIAL, INCIDENTAL OR CONSEQUENTIAL DAMAGES, WHETHER SUCH DAMAGES ARE SOUGHT IN CONTRACT, IN TORT (INCLUDING BUT NOT LIMITED TO NEGLIGENCE AND STRICT LIABILITY) OR OTHERWISE, AND TREX’S LIABILITY WITH RESPECT TO DEFECTIVE PRODUCTS SHALL IN NO EVENT EXCEED THE REPLACEMENT OF SUCH PRODUCTS OR REFUND OF THE PURCHASE PRICE, AS DESCRIBED ABOVE.

Some states do not allow the exclusion or limitation of incidental or consequential damages, so the above limitation or exclusion may not apply to you. This warranty gives you specific legal rights, and you may also have other rights that vary from state to state.

This warranty shall only be applicable and enforceable in the United States of America and Canada.

Copyright © 2010 Trex Company, Inc

Limited Commercial Warranty

Trex Company, Inc. (hereinafter “Trex”) warrants to the original end-user commercial purchaser (“Purchaser”) that, for a period of ten (10) years from the date of original commercial purchase, under normal commercial use and service conditions, Trex® products shall be free from material defects in workmanship and materials, and shall not split, splinter, rot or suffer structural damage from termites or fungal decay. If a defect occurs within the warranty period, Purchaser shall notify Trex in writing and, upon confirmation by an authorized Trex representative of the defect, Trex’s sole responsibility shall be, at its option, to either replace the defective item or refund the portion of the purchase price paid by Purchaser for such defective item (not including the cost of its initial installation).

For purposes of this warranty, a “commercial purchaser” shall refer to any purchaser other than an individual residential homeowner.

This warranty shall not cover and Trex shall not be responsible for costs and expenses incurred with respect to the removal of defective Trex products or the installation of replacement materials, including but not limited to labor and freight.

This warranty may be transferred to subsequent buyers of the property upon which the Trex products were originally installed.

Notwithstanding the foregoing, (a) with respect to hardware for the Trex Surroundings® gate (gate frame, hinges and screws), the term of the warranty shall be five (5) years from the date of original purchase, and (b) with respect to Trex Decorative Balusters, the limited warranty herein covering the paint coating shall be prorated in the following manner: 100% replacement for the first 5 years; and 50% replacement for the next 5 years.

To make a claim under this limited warranty, Purchaser, or any transferee, shall send to Trex, within the warranty period referred to above, a description of the claimed defect and proof of purchase, to the following address:

Trex Company, Inc.
Customer Relations
160 Exeter Drive
Winchester, VA 22603-8605

Trex does not warrant against and is not responsible for, and no implied warranty shall be deemed to cover, any condition attributable to: (1) improper installation of Trex products and/or failure to abide by Trex’s installation guidelines, including but not limited to improper gapping; (2) use of Trex products beyond normal commercial use, or in an application not recommended by Trex’s guidelines and local building codes; (3) movement, distortion, collapse or settling of the ground or the supporting structure on which Trex products are installed; (4) any act of God (such as flooding, hurricane, earthquake, lightning, etc.), environmental condition (such as air pollution, mold, mildew, etc.), staining from foreign substances (such as dirt, grease, oil, etc.), or normal weathering (defined as exposure to sunlight, weather and atmosphere which will cause any colored surface to gradually fade, chalk, or accumulate dirt or stains); (5) variations or changes in color of Trex products; (6) improper handling, storage, abuse or neglect of Trex products by Purchaser, any transferee or third parties; or (7) ordinary wear and tear.

No person or entity is authorized by Trex to make and Trex shall not be bound by any statement or representation as to the quality or performance of Trex products other than as contained in this warranty. This warranty may not be altered or amended except in a written instrument signed by Trex and Purchaser.

UNDER NO CIRCUMSTANCES WILL TREX BE LIABLE FOR SPECIAL, INCIDENTAL OR CONSEQUENTIAL DAMAGES, WHETHER SUCH DAMAGES ARE SOUGHT IN CONTRACT, IN TORT (INCLUDING BUT NOT LIMITED TO NEGLIGENCE AND STRICT LIABILITY) OR OTHERWISE, AND TREX’S LIABILITY WITH RESPECT TO DEFECTIVE PRODUCTS SHALL IN NO EVENT EXCEED THE REPLACEMENT OF SUCH PRODUCTS OR REFUND OF THE PURCHASE PRICE, AS DESCRIBED ABOVE.

Some states do not allow the exclusion or limitation of incidental or consequential damages, so the above limitation or exclusion may not apply to you. This warranty gives you specific legal rights, and you may also have other rights that vary from state to state.

This warranty shall only be applicable and enforceable in the United States of America and Canada.

Copyright © 2010 Trex Company, Inc

Trex Transcend™

25 Year Limited Residential Fade & Stain Warranty

For a period of twenty-five (25) years from the date of original purchase, Trex Company, Inc. (hereinafter “Trex”) warrants to the original end-user residential purchaser (the “Purchaser”) that Trex Transcend™ decking (the “Product”) will perform, under normal residential use and service conditions, as follows:

Fade Resistance: The Product shall not fade in color from light and weathering exposure as measured by color change of more than 5 Delta E (CIE) units.

The Product is designed to resist fading. No material is fade proof when exposed to years of UV exposure and the elements. The Product is designed to resist fading, and will not in any event fade by more than 5 Delta E (CIE) units.

Stain Resistance: The Product shall be resistant to permanent staining resulting from spills of food and beverage items including ketchup, mustard, salad oils, tea, wine, coffee, fruit punch, barbeque sauce, grease, sodas and other food and beverage related items that would typically be present on a residential deck, or mold and mildew naturally occurring in the environment, provided that such substances are removed from the Product with soap and water or mild household cleaners after no more than one (1) week of exposure of the food or beverage to the surface or first appearance of the mold and mildew.

Notwithstanding the foregoing, Trex does not warrant that the Product is stain-proof, and does not warrant stain resistance resulting from spilled or otherwise applied food and beverage substances which are not properly cleaned as provided above within one (1) week of exposure. In addition, materials not covered in the stain resistant warranty include abrasive compounds of acidic or basic pH, paints or stains, strong solvents, metallic rust or other abnormal residential deck use items, and non-food and non-beverage substances, including but not limited to, biocides, fungicides, plant food, or bactericides. Mold and mildew can settle and grow on any outdoor surface, including this Product. You should periodically clean your deck to remove dirt and pollen that can feed mold and mildew. This warranty does not cover mold and mildew which is not properly cleaned as provided above within one (1) week of first appearance.

Residential Purchaser: For purposes of this warranty, a “residential purchaser” shall refer to an individual residential homeowner.

Standard Trex Company Limited Residential Warranty: This warranty is in addition to the standard Trex Company Limited Residential Warranty that applies to all Trex products.

Transferability: This warranty may be transferred one (1) time, within the five (5) year period beginning from the date of original purchase by the Purchaser, to a subsequent buyer of the property upon which the Product was originally installed.

Exclusions from Warranty Coverage:

Exposure to Heat: Direct or indirect contact with extreme heat sources (over 250 degrees) or may cause fading and may damage the surface of the Product, and any effects of such exposure are expressly excluded from coverage under this warranty.

Surface Damage: Never use metal shovels or sharp-edged tools to remove snow and ice on the surface of the Product. If the surface of the Product is damaged or punctured, this warranty will be voided.

Paint Or Other Materials Applied to Trex Transcend Decking: If paint or other coating materials are applied to the Product, this warranty will be voided.

Railing: This warranty does not cover Trex Transcend railing components.

Other Exclusions: This warranty shall not cover any condition attributable to: (1) improper installation of the Product and/or failure to abide by Trex’s installation guidelines, including but not limited to improper gapping; (2) use of the Product beyond normal residential use, or in an application not recommended by Trex’s guidelines and local building codes; (3) movement, distortion, collapse or settling of the ground or the supporting structure on which the Product is installed; (4) any act of God (such as flooding, hurricane, earthquake, lightning, etc.), (5) improper handling, storage, abuse or neglect of the Product by Purchaser, the transferee or third parties, (6) any fading or staining not on the walking surface of the Product (i.e., the underside or the ends of the Product); or (7) ordinary wear and tear.

Procedure for Making a Claim under this Warranty

In order to make a claim under this warranty, Purchaser must do the following:

1. If the Purchaser is making a claim relating to the warranty on stain resistance, Purchaser must do as follows:
 - (a) Purchaser must try to clean the affected area of the deck by using the cleaning procedures described above within one (1) week of exposure of the food or beverage to the Product or first appearance of the mold and mildew.
 - (b) If the affected area remains reasonably unsatisfactory after Purchaser has tried these cleaning procedures, then Purchaser must have the affected area of the deck professionally cleaned at Purchaser's expense.
 - (c) If the affected area remains reasonably unsatisfactory after the professional cleaning, Purchaser may make a claim under this warranty, provided that such claim is made within thirty (30) days after the professional cleaning.
2. To make a claim under this limited warranty, Purchaser, or the transferee, shall send to Trex, within the warranty period referred to above (25 years after date of original purchase), a description and photographs of the affected area of the Product, proof of purchase, and if the claim relates to the warranty on stain resistance, proof of compliance with paragraph 1. above, to the following address:

Trex Company, Inc.
 Customer Relations
 160 Exeter Drive
 Winchester, VA 22603-8605

3. Upon confirmation by an authorized Trex representative of a valid claim hereunder, Trex's sole responsibility shall be, at its option, to either replace the affected item or refund the portion of the purchase price paid by Purchaser for such affected item (not including the cost of its initial installation). Replacement material will be provided that is as close as possible in color, design and quality as the replaced material, but Trex does not guarantee an exact match as colors and design may change.
4. If a valid warranty claim hereunder is made during years eleven (11) through twenty-five (25) after the original purchase, recovery will be prorated. If Trex is providing replacement materials, it may elect to replace the percentage listed below of boards otherwise meeting the requirements for a claim, or if it is refunding the purchase price, it may elect to refund the percentage listed below of the purchase price of boards otherwise meeting the requirements for a claim.

Year of Warranty Claim	Percentage Recovery
11	80%
12	80%
13	80%
14	60%
15	60%
16	60%
17	40%
18	40%

Year of Warranty Claim	Percentage Recovery
19	40%
20	20%
21	20%
22	20%
23	10%
24	10%
25	10%

5. This warranty shall not cover and Trex shall not be responsible for costs and expenses incurred with respect to the removal of affected Product or the installation of replacement materials, including but not limited to labor and freight.

Under no circumstances will Trex be liable for special, incidental or consequential damages, whether such damages are sought in contract, in tort (including but not limited to negligence and strict liability) or otherwise, and Trex's liability with respect to Products shall in no event exceed the replacement of such products or refund of the purchase price, as described above.

Some states do not allow the exclusion or limitation of incidental or consequential damages, so the above limitation or exclusion may not apply to you. This warranty gives you specific legal rights, and you may also have other rights that vary from state to state.

This warranty shall only be applicable and enforceable in the United States of America and Canada.

Trex Transcend™

10 Year Limited Commercial Fade & Stain Warranty

For a period of ten (10) years from the date of original purchase, Trex Company, Inc. (hereinafter “Trex”) warrants to the original end-user commercial purchaser (the “Purchaser”) that Trex Transcend™ decking (the “Product”) will perform, under normal commercial use and service conditions, as follows:

Fade Resistance: The Product shall not fade in color from light and weathering exposure as measured by color change of more than 5 Delta E (CIE) units.

The Product is designed to resist fading. No material is fade proof when exposed to years of UV exposure and the elements. The Product is designed to resist fading, and will not in any event fade by more than 5 Delta E (CIE) units.

Stain Resistance: The Product shall be resistant to permanent staining resulting from spills of food and beverage items including ketchup, mustard, salad oils, tea, wine, coffee, fruit punch, barbecue sauce, grease, sodas and other food and beverage related items that would typically be present on a deck, or mold and mildew naturally occurring in the environment, provided that such substances are removed from the Product with soap and water or mild household cleaners after no more than one (1) week of exposure of the food or beverage to the surface or first appearance of the mold and mildew.

Notwithstanding the foregoing, Trex does not warrant that the Product is stain-proof, and does not warrant stain resistance resulting from spilled or otherwise applied food and beverage substances which are not properly cleaned as provided above within one (1) week of exposure. In addition, materials not covered in the stain resistant warranty include abrasive compounds of acidic or basic pH, paints or stains, strong solvents, metallic rust or other abnormal commercial deck use items, and non-food and non-beverage substances, including but not limited to, biocides, fungicides, plant food, or bactericides. Mold and mildew can settle and grow on any outdoor surface, including this Product. You should periodically clean your deck to remove dirt and pollen that can feed mold and mildew. This warranty does not cover mold and mildew which is not properly cleaned as provided above within one (1) week of first appearance.

Commercial Purchaser: For purposes of this warranty, a “commercial purchaser” shall refer to any purchaser other than an individual residential homeowner.

Standard Trex Company Limited Commercial Warranty: This warranty is in addition to the standard Trex Company Limited Commercial Warranty that applies to all Trex products.

Transferability: This warranty may be transferred to subsequent buyers of the property upon which the Product was originally installed.

Exclusions from Warranty Coverage:

Exposure to Heat: Direct or indirect contact with extreme heat sources (over 250 degrees) may cause fading and may damage the surface of the Product, and any effects of such exposure are expressly excluded from coverage under this warranty.

Surface Damage: Never use metal shovels or sharp-edged tools to remove snow and ice on the surface of the Product. If the surface of the Product is damaged or punctured, this warranty will be voided.

Paint Or Other Materials Applied to Trex Transcend Decking: If paint or other coating materials are applied to the Product, this warranty will be voided.

Railing: This warranty does not cover Trex Transcend railing components.

Other Exclusions: This warranty shall not cover any condition attributable to: (1) improper installation of the Product and/or failure to abide by Trex’s installation guidelines, including but not limited to improper gapping; (2) use of the Product beyond normal commercial use, or in an application not recommended by Trex’s guidelines and local building codes; (3) movement, distortion, collapse or settling of the ground or the supporting structure on which the Product is installed; (4) any act of God (such as flooding, hurricane, earthquake, lightning, etc.), (5) improper handling, storage, abuse or neglect of the Product by Purchaser, any transferee or third parties, (6) any fading or staining not on the walking surface of the Product (i.e., the underside or the ends of the Product); or (7) ordinary wear and tear.

Procedure for Making a Claim under this Warranty

In order to make a claim under this warranty, Purchaser must do the following:

1. If the Purchaser is making a claim relating to the warranty on stain resistance, Purchaser must do as follows:
 - (a) Purchaser must try to clean the affected area of the deck by using the cleaning procedures described above within one (1) week of exposure of the food or beverage to the Product or first appearance of the mold and mildew.
 - (b) If the affected area remains reasonably unsatisfactory after Purchaser has tried these cleaning procedures, then Purchaser must have the affected area of the deck professionally cleaned at Purchaser's expense.
 - (c) If the affected area remains reasonably unsatisfactory after the professional cleaning, Purchaser may make a claim under this warranty, provided that such claim is made within thirty (30) days after the professional cleaning.
2. To make a claim under this limited warranty, Purchaser, or the transferee, shall send to Trex, within the warranty period referred to above (10 years after date of original purchase), a description and photographs of the affected area of the Product, proof of purchase, and if the claim relates to the warranty on stain resistance, proof of compliance with paragraph 1. above, to the following address:

Trex Company, Inc.
Customer Relations
160 Exeter Drive
Winchester, VA 22603-8605

3. Upon confirmation by an authorized Trex representative of a valid claim hereunder, Trex's sole responsibility shall be, at its option, to either replace the affected item or refund the portion of the purchase price paid by Purchaser for such affected item (not including the cost of its initial installation). Replacement material will be provided that is as close as possible in color, design and quality as the replaced material, but Trex does not guarantee an exact match as colors and design may change.
4. **This warranty shall not cover and Trex shall not be responsible for costs and expenses incurred with respect to the removal of affected Product or the installation of replacement materials, including but not limited to labor and freight.**

Under no circumstances will Trex be liable for special, incidental or consequential damages, whether such damages are sought in contract, in tort (including but not limited to negligence and strict liability) or otherwise, and Trex's liability with respect to Products shall in no event exceed the replacement of such products or refund of the purchase price, as described above.

Some states do not allow the exclusion or limitation of incidental or consequential damages, so the above limitation or exclusion may not apply to you. This warranty gives you specific legal rights, and you may also have other rights that vary from state to state.

This warranty shall only be applicable and enforceable in the United States of America and Canada.

Physical and Mechanical Properties for Trex Accents, Brasilia, Contours and Origins

	Test Method	Values	
Abrasion Resistance	ASTM D2394	.01 wear/1000 revs.	
Hardness	ASTM D143	562 kg (5 kn)	
Self Ignition Temperature	ASTM D1929	743°F (395 C)	
Flash Ignition Temperature	ASTM D1929	698°F (370 C)	
Flame Spread (a) [Fire Defense™]	ASTM E84	80 [40]	
Water Absorption (sanded surface) 24 hr. immersion	ASTM D1037	4.3%	
Water Absorption (unsanded surface) 24 hr. immersion	ASTM D1037	1.7%	
Typical Trex® values for Coefficient of Thermal Expansion/Contraction (36" long samples)			
Thermal	Width	35.2 x 10 ⁻⁶ to 42.7 x 10 ⁻⁶ (inch/inch/°F) 644 x 10 ⁻⁶ to 776 x 10 ⁻⁶ (length/length/C)	
	Length	16.1 x 10 ⁻⁶ to 19.2 x 10 ⁻⁶ (inch/inch/°F) 297 x 10 ⁻⁶ to 356 x 10 ⁻⁶ (length/length/C)	
Moisture	Typical Trex values for Long Term Water Immersion (36"/91.4 cm long samples)	Typical Trex values for Constant High Humidity (6"/15.2 long samples)	
	Width ~3%	~1%	
Nail Withdrawal (c)	ASTM D1761	163 lbs/in (1.12 Mpa)	
Screw Withdrawal (c)	ASTM D1761	558 lbs/in (3.85 Mpa)	
Static Coefficient of Friction - Dry (d)	ASTM D2047	0.53/0.55	
Static Coefficient of Friction - Dry (d)	ASTM F1679	0.59/0.70	
Static Coefficient of Friction - Wet (d)	ASTM F1679	0.70/0.75	
Fungus Resistance (White & Brown Rot)	ASTM D1413	rating = No Decay	
Termite Resistance (e)	AWPAE1-72	rating = 9.6	
Specific Gravity (typical)	ASTM D2395	0.91 to 0.95	
		Ultimate (typical) Values	Design Values
Compression Parallel (f)(g)	ASTM D198	1806 psi (12.45 Mpa)	550 psi (3.79 Mpa)
Compression Perpendicular (f)(h)	ASTM D143	1944 psi (13.40 Mpa)	625 psi (4.31 Mpa)
Tensile Strength (f)	ASTM D198	854 psi (5.89 Mpa)	250 psi (1.72 Mpa)
Shear Strength (f)	ASTM D143	561 psi (3.87 Mpa)	200 psi (1.38 Mpa)
Modulus of Rupture (f)	ASTM D4761	1423 psi (9.81 Mpa)	250 psi (1.72 Mpa)
Modulus of Elasticity (f)	ASTM D4761	175,000 psi (1206 Mpa)	100,000 psi (689.48 Mpa)
Thermal Conductivity	ASTM C177	1.57 BTU-in/hr-ft @85°F (.0023 W/cm/C)	
Leachate (I)	TCLP-EPA 1311	pass	

Notes:

- (a) Corresponding Smoke Developed Index is 285.
- (b) Values shown are for reference only. These values should not be used to calculate gapping for Trex. Follow Trex installation literature for proper width to width and end to end gapping information.
- (c) 8d common wire nail. No. 10 wood screw.
- (d) ASTM D2047 test conducted on sanded/unsanded unweathered samples with leather surface.
ASTM F1679 test conducted on sanded/unsanded weathered samples with neolite surface.
- (e) Material weight loss was 0%.
- (f) ultimate strength values are not meant for design analysis. Testing performed on a 2x6 (5 cm x 15 cm) cross section. Design values are for temperatures up to 130°F (54 C).
- (g) Compressive strength parallel to the length.
- (h) Compressive strength perpendicular to length.
- (i) Leaching was below levels established by EPA for all constituent categories.

DECKING

TRANSCEND DECKING

TREE HOUSE

FIRE PIT

VINTAGE LANTERN

GRAVEL PATH

COLOR NOW AND 25 YEARS FROM NOW

COLOR NOW AND 25 YEARS FROM NOW

COLOR NOW AND 25 YEARS FROM NOW

COLOR NOW AND 25 YEARS FROM NOW

BRASILIA DECKING

BURNISHED AMBER

UNWEATHERED

WEATHERED

CAYENNE

UNWEATHERED

WEATHERED

ESPRESSO

UNWEATHERED

WEATHERED

ACCENTS DECKING

SADDLE

UNWEATHERED

WEATHERED

MADEIRA

UNWEATHERED

WEATHERED

WOODLAND BROWN

UNWEATHERED

WEATHERED

WINCHESTER GREY

UNWEATHERED

WEATHERED

CONTOURS DECKING

SADDLE

UNWEATHERED

WEATHERED

MADEIRA

UNWEATHERED

WEATHERED

WINCHESTER GREY

UNWEATHERED

WEATHERED

ESCAPES DECKING

ACORN

UNWEATHERED

PEWTER

UNWEATHERED

RAILING

TRANSCEND RAILING

TREE HOUSE

FIRE PIT

VINTAGE LANTERN

GRAVEL PATH

CHARCOAL BLACK

CLASSIC WHITE

DESIGNER / TRADITIONAL RAILING

SADDLE

MADEIRA

WOODLAND BROWN

WINCHESTER GREY

BURNISHED AMBER

CAYENNE



decking: Trex Accents®
in Saddle & Woodland Brown
railing: Trex Transcend™
in Classic White and
Trex Designer Series Railing®
in Woodland Brown
fascia: TrexTrim™

Trex®

How outdoor living should feel.

visit **trex.com** or call **1-800-BUY-TREX**

© 2010 Trex Company, Inc. All rights reserved. Trex®, the Trex logo, Trex Transcend™, Trex Brasilia®, Trex Accents®, Trex Contours®, Trex Escapes®, Trex Designer Series Railing®, Trex Hideaway®, TrexTrim™, and TrexExpress™ are either federally registered trademarks, trademarks or trade dress of Trex Company, Inc., Winchester, Virginia.

DKRLL T02-0310