

INSTALLATION GUIDE

TIMBER CURTAIN WALL



A subsidiary of Unicel Architectural Corp.
PHONE: 418-659-5005

TABLE OF CONTENTS:

PAGE 1	TRANSOM INSERTION
PAGE 2	MEMBRANE INSTALLATION
PAGE 3	CHECKING GASKETS
PAGE 4	GLASS INSTALLATION
PAGE 5 TO 7	PRESSURE PLATE INSTALLATION
PAGE 8 TO 9	CAP PROFILE INSTALLATION AND ASSEMBLY

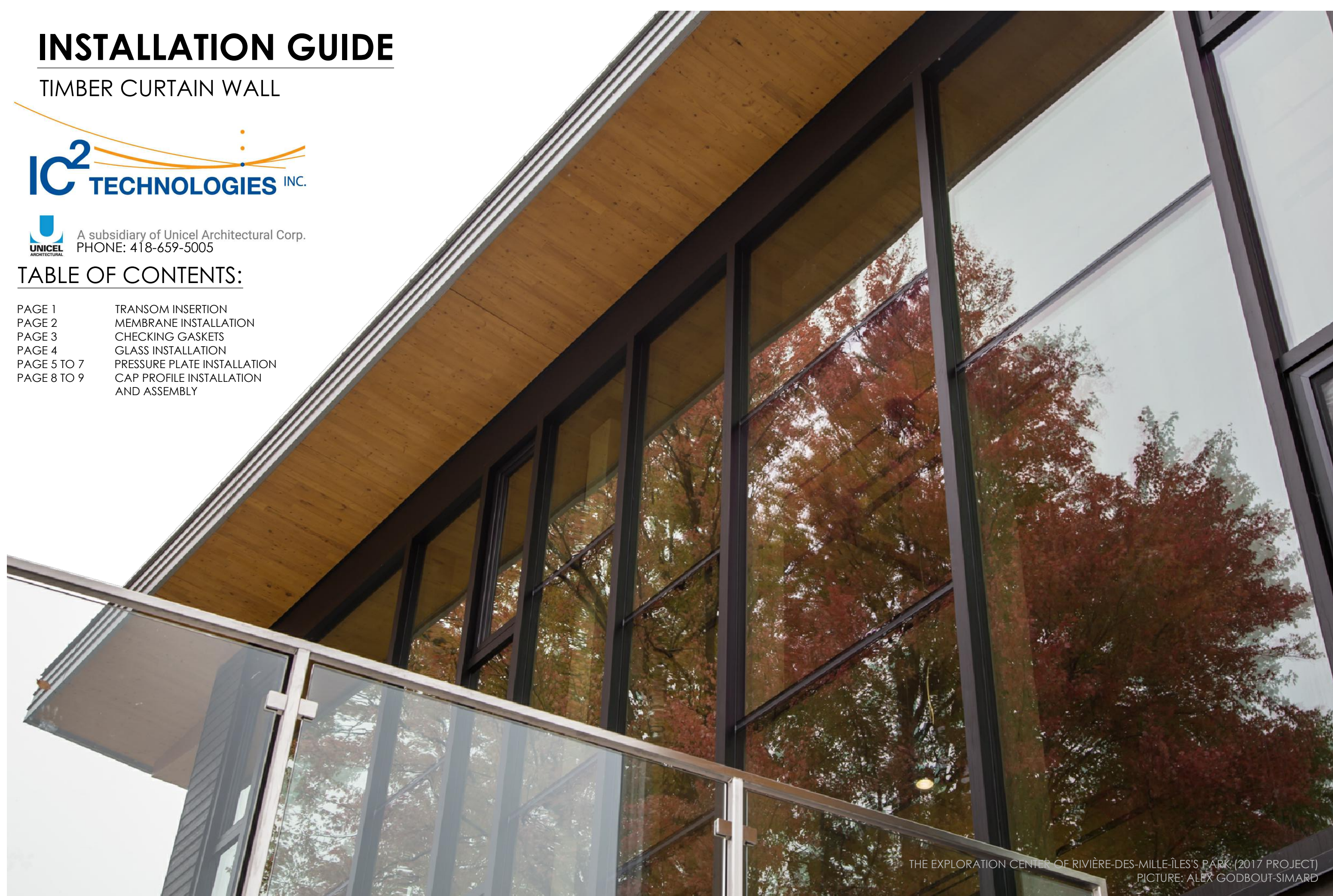

TRANSOM INSERTION

TIMBER CURTAIN WALL:

THE CURTAIN WALL ARRIVES ON SITE IN PRE-ASSEMBLED MODULES. A CURTAIN WALL ASSEMBLY (FAÇADE) CAN HAVE SEVERAL MODULES WHICH HELP TO FACILITATE TRANSPORTATION. ONCE ON SITE, THE ASSEMBLY MUST BE FINALIZED BY INSERTING THE CONNECTING TRANSOMS BETWEEN THE MULLION SECTIONS.

IT MAY OCCUR ON CERTAIN PROJECTS THAT TRANSOMS COME INTO CONFLICT WITH STRUCTURAL ELEMENTS SUCH AS COLUMNS, BEAMS, WALLS OR MECHANICAL INSTALLATIONS. IN SUCH CASES, THE *SPECIAL METHOD* MUST BE USED TO INSERT AND INSTALL THE TRANSOMS.

IN THE SPECIAL METHOD, THE TRANSOM NEEDS TO BE INSTALLED STARTING FROM THE OUTSIDE OF THE BUILDING AND SLID TOWARDS THE INSIDE. IF THIS METHOD IS USED, THEN THE CONNECTORS ON THE TRANSOM MUST BE MILLED ALL THE WAY THRU FROM ONE SIDE TO THE OTHER. WOOD BLOCKS WILL BE USED TO HIDE THE CONNECTORS ON THE INSIDE OF THE BUILDING AFTER INSERTION.

SELECTION AND ACCESSORIES OF SOLO CONNECTION

TRANSOM DEPTH (mm)	TC TIMBER CONNECTOR PU: 10 PCS		NAIL SCREW PU: 100 PCS	
	NO.	SET	NO.	SET
60 TO 79	161302	60	908554	2 PCS
80 TO 99	161307	80	908555	2 PCS
100 TO 119	161312	100	908556	2 PCS
120 TO 159	161317	120	908557	2 PCS
160 TO 199	161322	160	908558	2 PCS
200 TO 239	161327	200	908559	2 PCS
240 TO 300	161332	240	908560	2 PCS

ASSEMBLY AT THE BUILDING SITE:

(EXTRACT FROM RAICO'MANUAL)

SLIDE THE TRANSOM IN BETWEEN THE MULLIONS ACCORDING TO THE METHOD TO BE USED.

1) FOR THE CONVENTIONAL METHOD

- STARTING FROM THE INSIDE OF THE BUILDING, SLIDE THE TRANSOM BETWEEN THE MULLIONS, AND TOWARDS THE OUTSIDE OF THE BUILDING. PRESS THE TRANSOM UNTIL IT IS IN PLACE.

2) FOR THE SPECIAL METHOD

- STARTING FROM THE OUTSIDE OF THE BUILDING, SLIDE THE TRANSOM BETWEEN THE MULLIONS, AND TOWARDS THE INSIDE OF THE BUILDING. PRESS THE TRANSOM UNTIL IT IS FLUSH WITH THE MULLION.

3) THE NAIL SCREWS MUST BE EASY TO INSERT UP TO THE THREADS.

4) TIGHTEN THE SPECIAL NAIL-SCREW. (MAKE SUR TRANSOM AND MULLION ARE FLUSH BEFORE TIGHTENING)

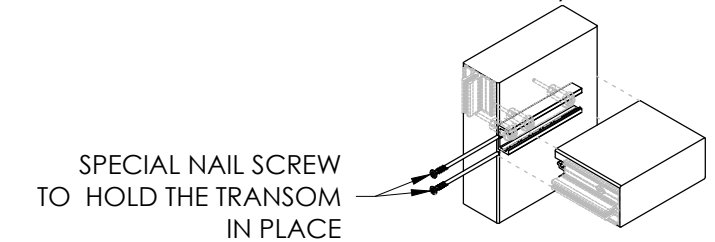

DIAGRAM 3: NAIL SCREW INSTALLATION

CONVENTIONAL METHOD:

(INSIDE VIEW)

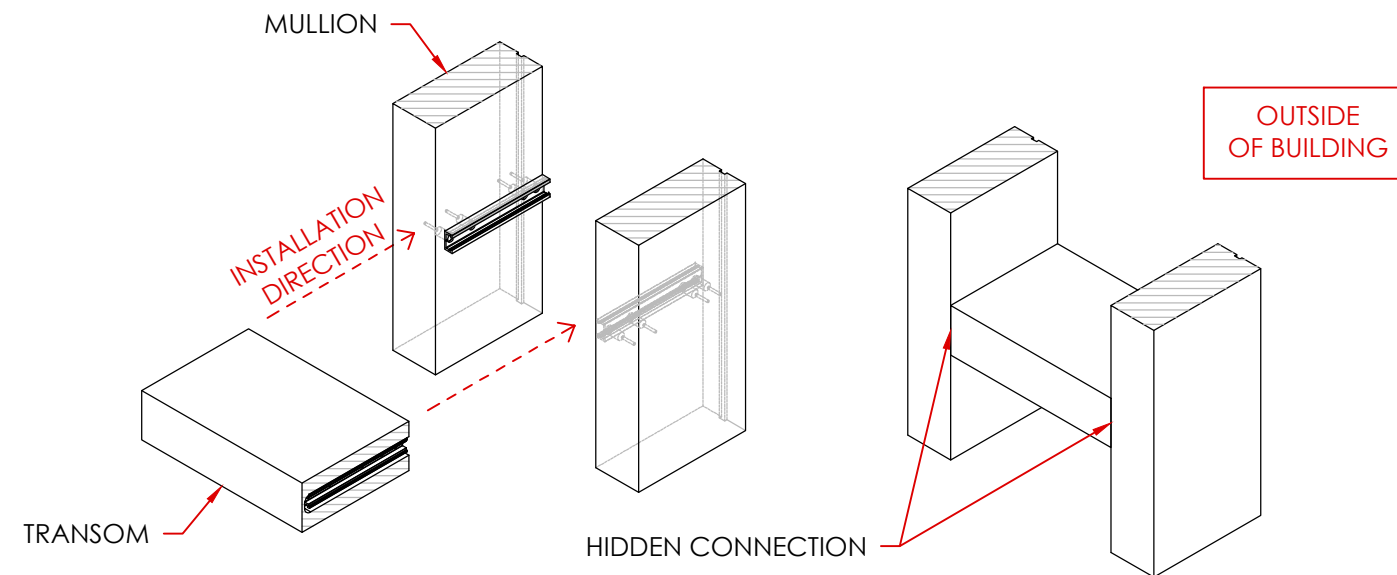

DIAGRAM 1: CONVENTIONAL TRANSOM INSERTION FROM THE INSIDE OF THE BUILDING TO THE OUTSIDE, WITH HIDDEN MACHINING.

SPECIAL METHOD:

(INSIDE VIEW)

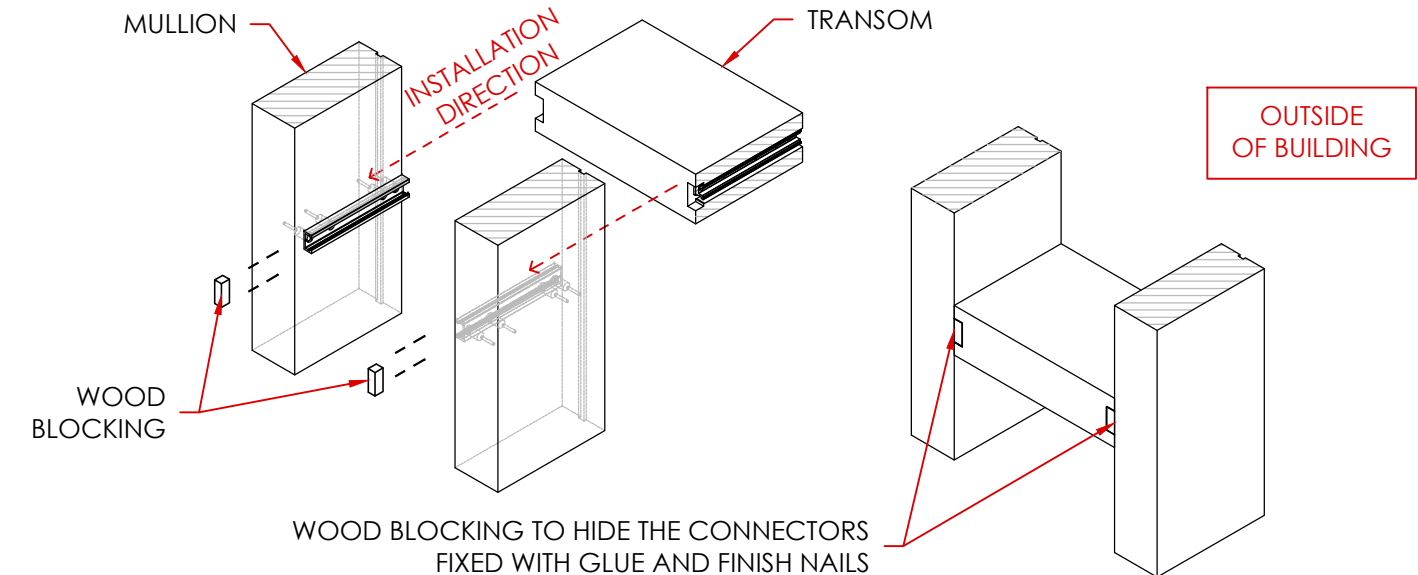

DIAGRAM 2: TRANSOM INSERTION FROM THE OUTSIDE OF THE BUILDING TO THE INSIDE, WITH VISIBLE MACHINING.

MEMBRANE INSTALLATION

PERIMETER MEMBRANE:

ALL MULLIONS AND TRANSOMS AROUND THE PERIMETER ARRIVE AT THE JOB SITE WITH A MEMBRANE ALREADY PRE-INSTALLED ON THEM AT THE FACTORY. THIS METHOD ACCELERATES THE INSTALLATION PROCESS OF MODULES, AND ENSURES CONTINUOUS AND OPTIMAL SEALING. REFER TO THE DOCUMENTS SUPPLIED IN THE WORKSHOP SPECIFICATIONS TO COORDINATE THE ASSEMBLY AND ANCHORING OF TIMBER CURTAIN WALLS. ONCE ALL MODULES ARE ASSEMBLED AND INSTALLED, IT IS ESSENTIAL TO SEAL THE CURTAIN WALL WITH THE BUILDING ENVELOPE. PLEASE NOTE THAT ALL STEPS INDICATED ON THIS PAGE ARE TO ILLUSTRATE THE MEMBRANE OVERLAP ON THE CURTAIN WALL ONLY.



PICTURE 1: SEE DESCRIPTION OF STEP 1

STEP 1:

REMOVE THE BASE GASKET PROFILE TO EXPOSE THE OVERLAPPING MEMBRANE AREA. REMOVE THE BASE PROFILE THAT WAS ALREADY INSTALLED ON THE MULLION, AND KEEP IT NEARBY WITH THE 2 SCREWS. CUT WITH AN EXACTO KNIFE THE LENGTH NEEDED FOR THE LEFT MEMBRANE. THE LONGITUDINAL OVERLAP MUST BE AT LEAST 50mm (2 inches). PLEASE SEE TECHNICAL DATA SHEET.



PICTURE 2: SEE DESCRIPTION OF STEP 2

STEP 2:

MAKE THE SAME ADJUSTMENT TO THE RIGHT SECTION MEMBRANE. PLEASE REFER TO STEP #1.



PICTURE 3: SEE DESCRIPTION OF STEP 3

STEP 3:

PRESS TO ADHERE THE LEFT SECTION MEMBRANE DIRECTLY ONTO THE WOOD MULLION. FOLLOWING THIS, OVERLAP THE RIGHT SIDE ON TOP OF THE LEFT SIDE, AND BOND THE TWO MEMBRANES TOGETHER.



PICTURE 4: SEE DESCRIPTION OF STEP 4

STEP 4:

WHEN THE MEMBRANES ARE GLUED AND BONDED TOGETHER, REINSTALL THE BASE PROFILE ON THE MULLION WITH THE 2 SCREWS. REPLACE THE MULLION GASKET FIRST AND THEN THE TRANSOM GASKET AFTER. MAKE SURE THAT THE GASKETS ARE WELL INSERTED ABOVE THE BASE PROFILE.

NOTE:
ENSURE THAT THE EPDM SEALING FOAM PIECES ARE IN PLACE AND THEY HAVE NOT BEEN DAMAGED WHEN HANDLING THE GASKETS. REPLACE IF NECESSARY (SEE **DIAGRAM 4**/ PAGE 3).

IT'S THE RESPONSIBILITY OF THE CONTRACTOR TO INSTALL THE MEMBRANE PROPERLY AND TO FOLLOW THE OVERLAP INDICATED IN THE WORKSHOP DRAWINGS APPROVED BY THE ARCHITECT. IN NO CIRCUMSTANCES SHALL THE CONTRACTOR USE NON-SEALED PLANS FOR THE INSTALLATION OF TIMBER CURTAIN WALLS. WHEN BONDING THE MEMBRANE ONTO THE ENVELOPE OF THE BUILDING, SIMPLY FOLLOW THE INSTRUCTIONS OF THE MANUFACTURER BEFORE REMOVING PROTECTIVE COATING.

CHECKING GASKETS

RAICO'S SEALING PIECE TO BE USED:
REFER TO ASSEMBLY PLANS AND DRAINING PLANS FOR THE SEALING
PIECE PART NUMBER TO BE USED. THE RAICO CODE IS WRITTEN ON THE
BAGS PROVIDED WITH THE DELIVERY AT THE JOB SITE.

MAKE SURE EPDM SEALING FOAMS FOR TRANSOMS ARE IN PLACE AND
IN GREAT CONDITION AT THE END OF THE GASKET.
IF EPDM SEALING FOAM ARE DAMAGED OR REMOVED,
REPLACE WITH A NEW ONE.

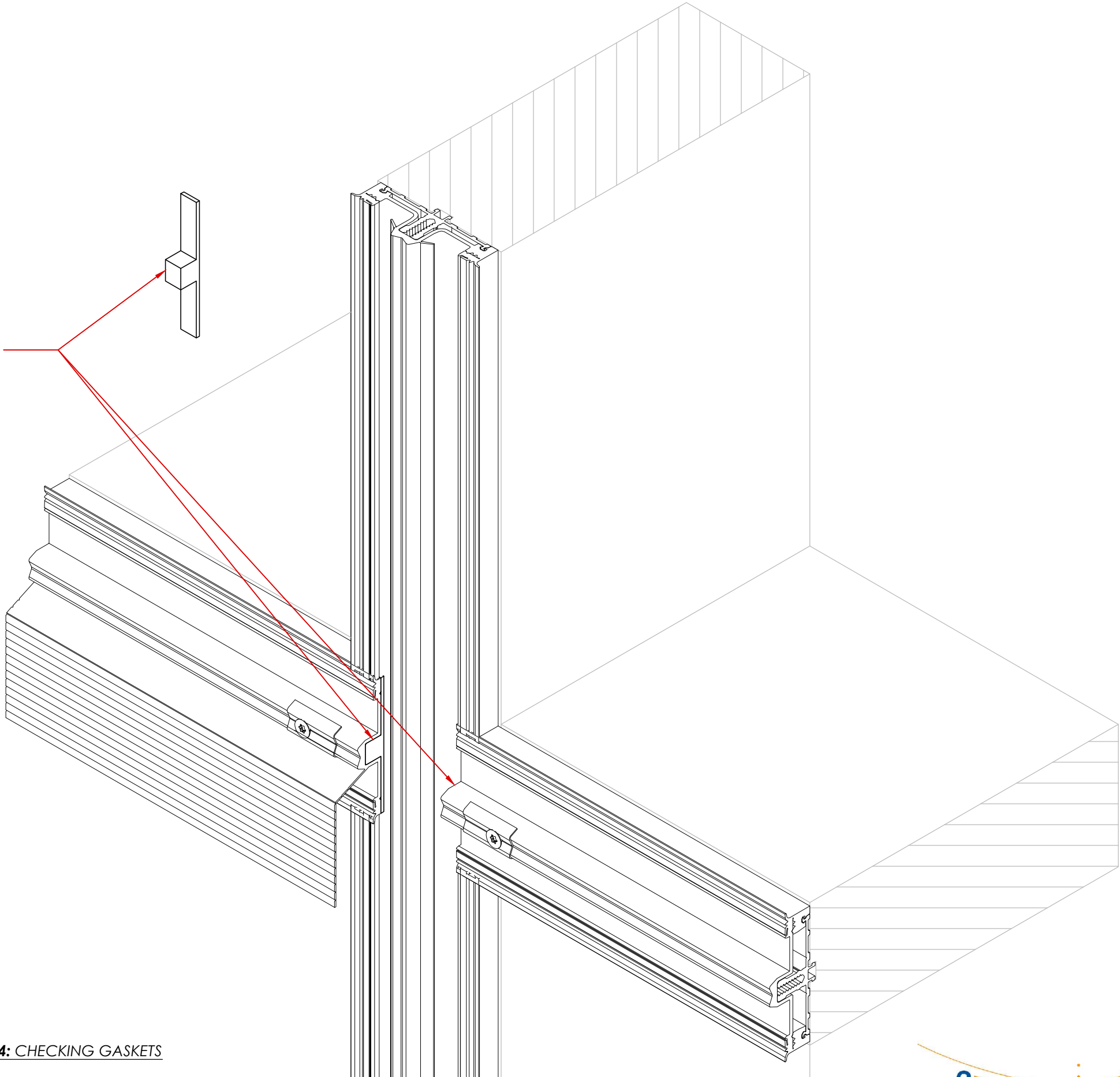

DIAGRAM 4: CHECKING GASKETS

GLASS INSTALLATION

TEMPORARY PRESSURE PLATES:

WHEN ALL GASKET SEALING IS CHECKED, GLASS MAY BE INSTALLED ON GLASS CARRIERS INSTALLED AT THE FACTORY. CENTER THE GLASS IN THE OPENINGS AND USE THE APPROPRIATE SIZES OF SETTING BLOCKS (100mm WIDE BY SAME DEPTH OF GLAZING). THE USE OF TEMPORARY PRESSURE PLATES IS REQUIRED TO HOLD THE PANES OF GLASS IN PLACE AND TO INSTALL THE SELF-ADHESIVE CROSS POINT SEALING PLATES. AN APPROPRIATE QUANTITY OF TEMPORARY PRESSURE PLATES WILL ALSO BE INCLUDED IN THE SHIPMENT OF THE CURTAIN WALL. THE CROSS POINT SEALING PLATE IS USED TO PROVIDE A CONTINUOUS SEAL ACROSS WINDOW SECTIONS.



MARIE-CLAUDE LAVOIE RESIDENCE (2013 PROJECT)
PICTURE: IC² TECHNOLOGIES INC.

- TO INSTALL SELF-ADHESIVE CROSS POINT SEALING PLATE, FOLLOW THESE STEPS:
- 1- CLEAN THE GLASS CORNERS WITH ACETONE;
 - 2- STICK THE PLATES DIRECTELY ON THE GLAZING, EXCEPT WHEN THE GASKETS HAVE FLAP.

NOTE:
IT'S RECOMMEND TO STICK THE CROSS POINT SEALING PLATES ABOVE THE GASKET FOR THE TRANSOM WITH FLAP TO ENSURE A WATERPROOF BARRIER. IF THE CROSS POINT SEALING PLATES DON'T STICK ON THE EPDM FLAP, IT'S POSSIBLE TO CUT A PART OF THE FLAP WITH SCISSORS TO ALLOW THE PLATE TO STICK DIRECTLY ONTO THE GLASS. PLEASE TAKE INTO CONSIDERATION THAT THIS ALTERNATIVE METHOD IS NOT RECOMMENDED.

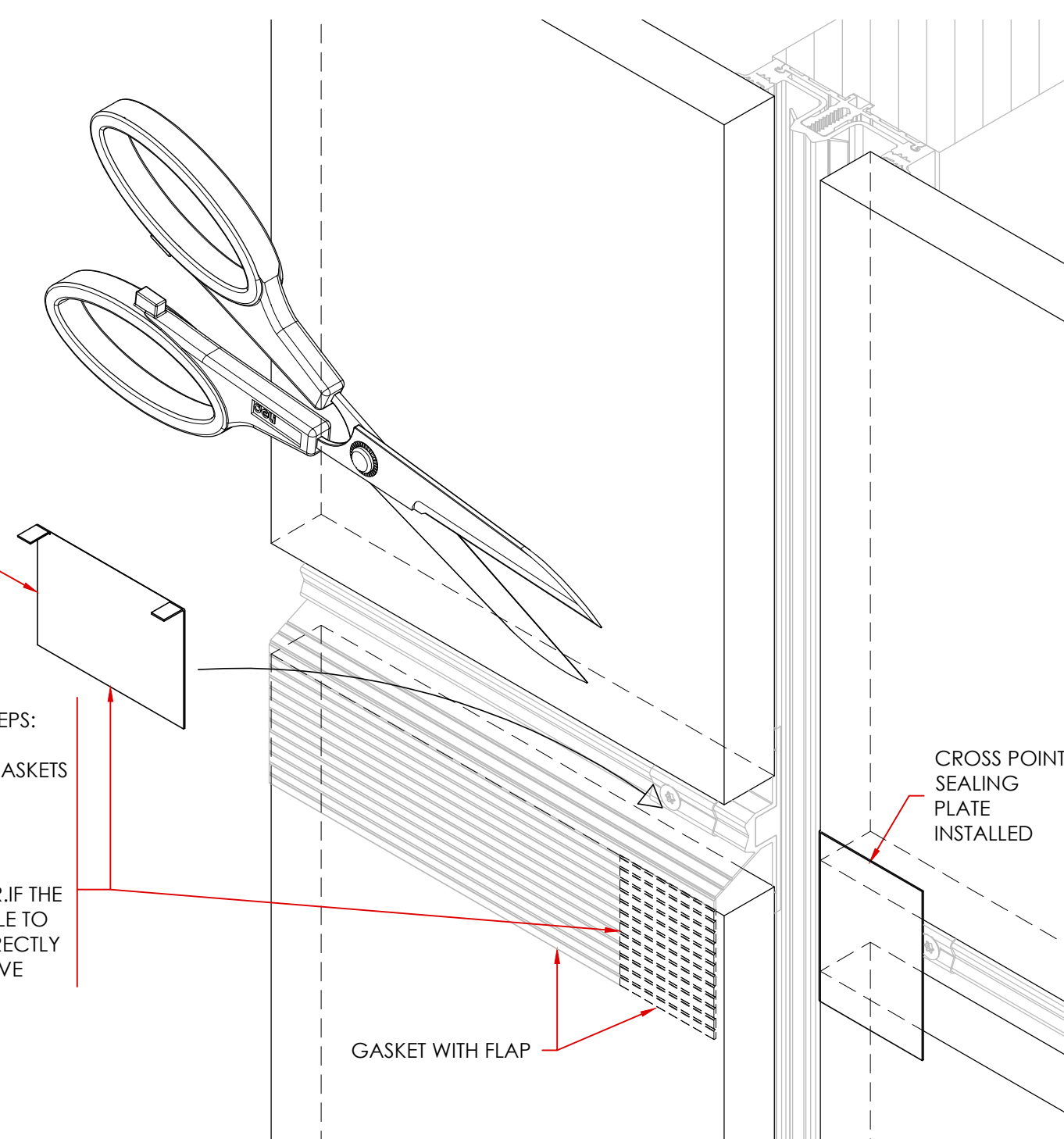
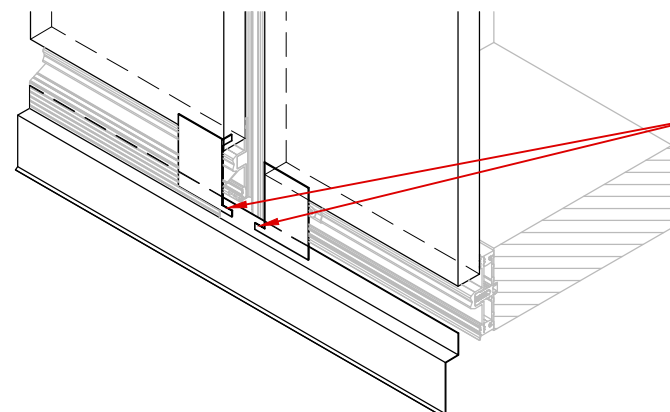

DIAGRAM 5: CROSS POINT SEALING PLATE INSTALLATION



FOR THE GLASS JUNCTION WITH PERIMETER METALLIC FLASHING, UNFOLD ONE OF THE CROSS POINT SEALING PLATE LEGS AND STICK THE PLATE IN PLACE.

THE CROSS POINT SEALING PLATES MUST BE INSTALLED VERTICALLY OR HORIZONTALLY ACCORDING TO THE PRESSURE PLATE ORIENTATION. IF THE VERTICAL MULLION IS CONTINUOUS, THEN THE SEALING PLATE MUST ALSO BE IN THE VERTICAL POSITION. DIAGRAM 5 DEPICTS THE SITUATION WHERE YOU HAVE A CONTINUOUS VERTICAL MULLION, WITH TRANSOM PRESSURE PLATES THAT STOP AT THE VERTICAL MULLION. SINCE THE CONTINUOUS PRESSURE PLATE IS VERTICAL, THE CROSS POINT SEALING PLATES SHOULD BE IN THE VERTICAL POSITION.

DIAGRAM 6: GLASS JUNCTION WITH PERIMETER METALLIC FLASHING

PRESSURE PLATES INSTALLATION

GENERAL INSTRUCTIONS

BEFORE INSTALLING THE PRESSURE PLATES:

- 1- CHECK THE CONDITION OF THE EPDM SEALING FOAM PIECES LOCATION AT THE END OF THE PRESSURE PLATES (SEE **DIAGRAM 8**).
- 2- LUBRICATE THE GASKETS WITH SILICONE BASED LUBRICANT (SEE **DIAGRAM 7**).
- 3- SEE THE ASSEMBLY INSTRUCTIONS ON THE NEXT PAGE.

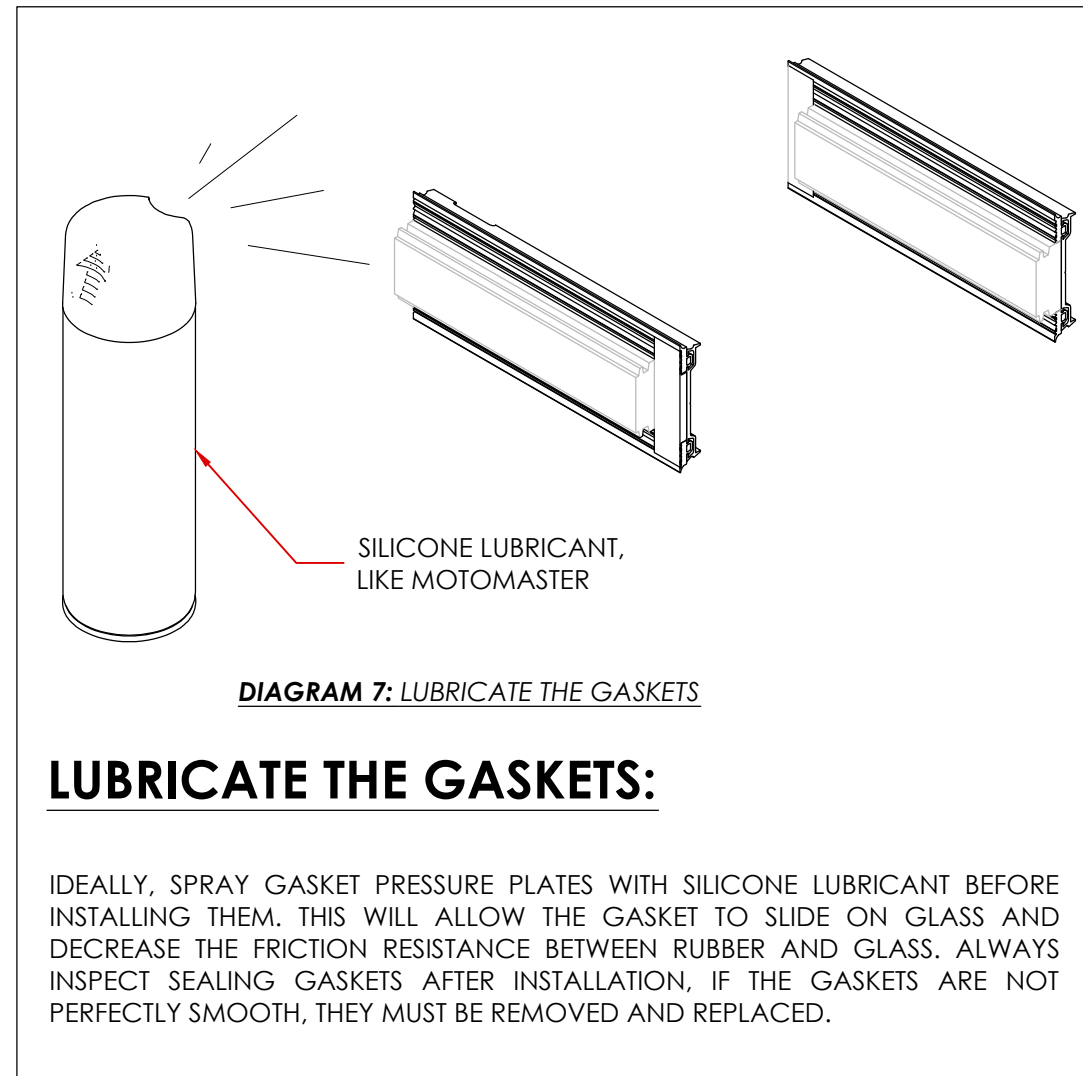

RAICO'S SEALING PIECE TO BE USED:
REFER TO ASSEMBLY PLANS AND DRAINING PLANS FOR THE SEALING PIECE PART NUMBER TO BE USED. THE RAICO CODE IS WRITTEN ON THE BAGS PROVIDED WITH THE DELIVERY AT THE JOB SITE.

DIAGRAM 8: CHECKING THE SEALING FOAMS

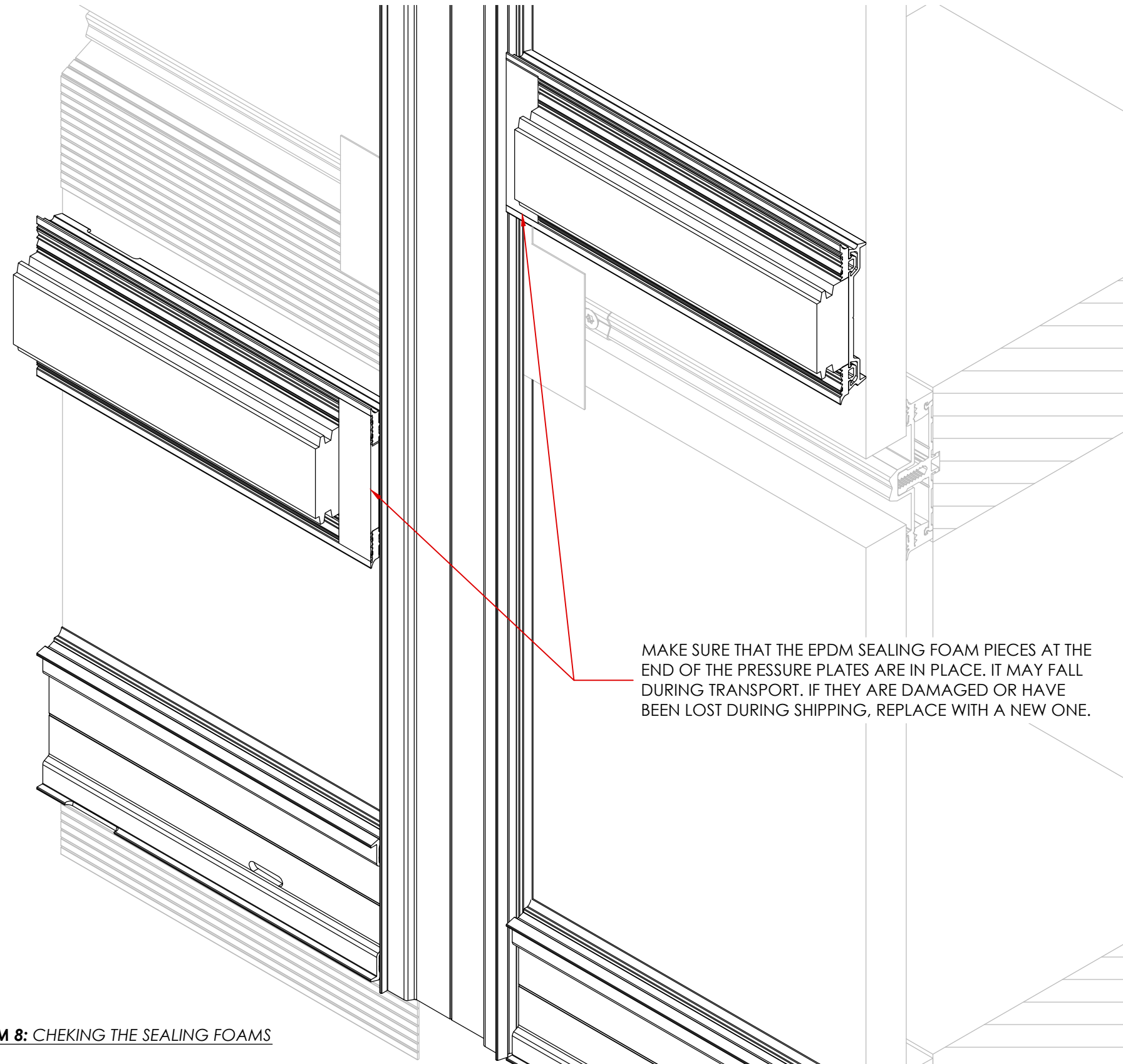

PRESSURE PLATE INSTALLATION

GENERAL INSTRUCTIONS:

1. CONTINUOUS PRESSURE PLATES MUST BE INSTALLED FIRST.

NOTE 1: ENSURE THAT HORIZONTAL PRESSURE PLATE WITH THE VENTILATION/ DRAIN OPENINGS ARE INSTALLED IN THE RIGHT ORIENTATION (DOWNWARDS FACING) REFER TO **DIAGRAM 10**.

NOTE 2: FOR LARGE HEIGHT PROJECTS (OVER 6 METERS), THE PRESSURE PLATE MUST BE SPLICED TOGETHER AND SEALED ACCORDING TO THE SPECIFICATIONS PROVIDED ON PAGE 8 ON THE INSTALLATION GUIDE. (REFER TO **DIAGRAM 14 / 15**)

2. TECHNICAL SPECIFICATIONS TO BE FOLLOWED (EXTRACTED FROM RAICO'S MANUAL)

- 2.1. - USE A SCREWDRIVER WITH AN ADJUSTABLE TORQUE LIMITER SET TO 4,5Nm (3.3FT/LBS).
- 2.2. - SCREWS SHOULD BE SCREWED IN AT A SPACING OF 250mm C/C (PRESSURE PLATE IS ALREADY PRE-DRILLED).
- 2.3. - CHECK THE APPEARANCE AND SHAPE OF THE EXTERIOR GASKET AND THE PRESSURE PLATE AFTER TIGHTENING.
 - GASKETS MUST NOT BULGE OUT OF THE SIDE, AND THE PRESSURE PLATE MUST REMAIN STRAIGHT WITH NO DEFLECTION OR BOWING.
 - IF NECESSARY, SLIGHTLY REDUCE OR INCREASE THE TORQUE TO ACHIEVE IDEAL PRESSURE ON THE GLASS.
- 2.4. - THE PRESSURE IS CORRECT IF THE EXTERIOR GASKET SHOWS NO DISTORTION AND LIES EVENLY IN ITS PLACE AND DOES NOT LIFT BETWEEN SCREWING POINTS.(REFER TO **DIAGRAM 9.1**).
- 2.5. WHEN SCREWING IN THE PRESSURE PLATE, THE SCREWS SHOULD BE DRIVEN IN AT ALL THE SAME HEIGHT, AND SHOULD NOT DIFFER MORE THAN 0.5mm IN TOTAL LENGTH. (REFER TO **DIAGRAM 9.1**)

3. CHECK THE ALIGNMENT OF THE VERTICAL AND HORIZONTAL PRESSURE PLATES (SEE **DIAGRAM 10**).

IMPORTANT:
BE SURE TO SCREW THE PRESSURE PLATES PERPENDICULAR TO THE GLAZING. INADEQUATE OR UNEVEN SCREWING OF THE PRESSURE PLATE MAY RESULT IN THE DAMAGE OR BREAKING OF GLASS OR PRESSURE PLATE.

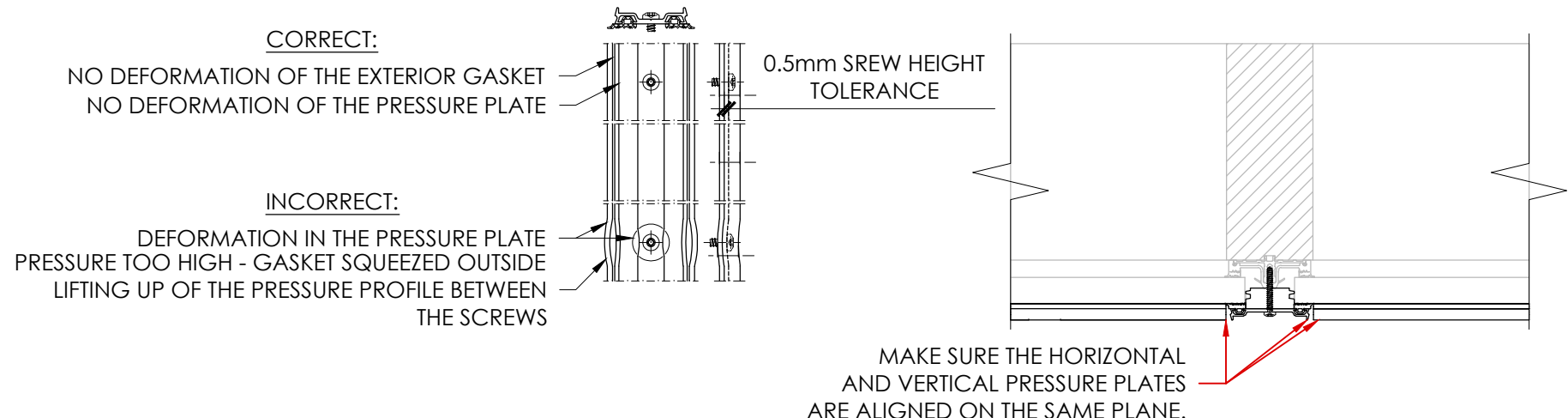
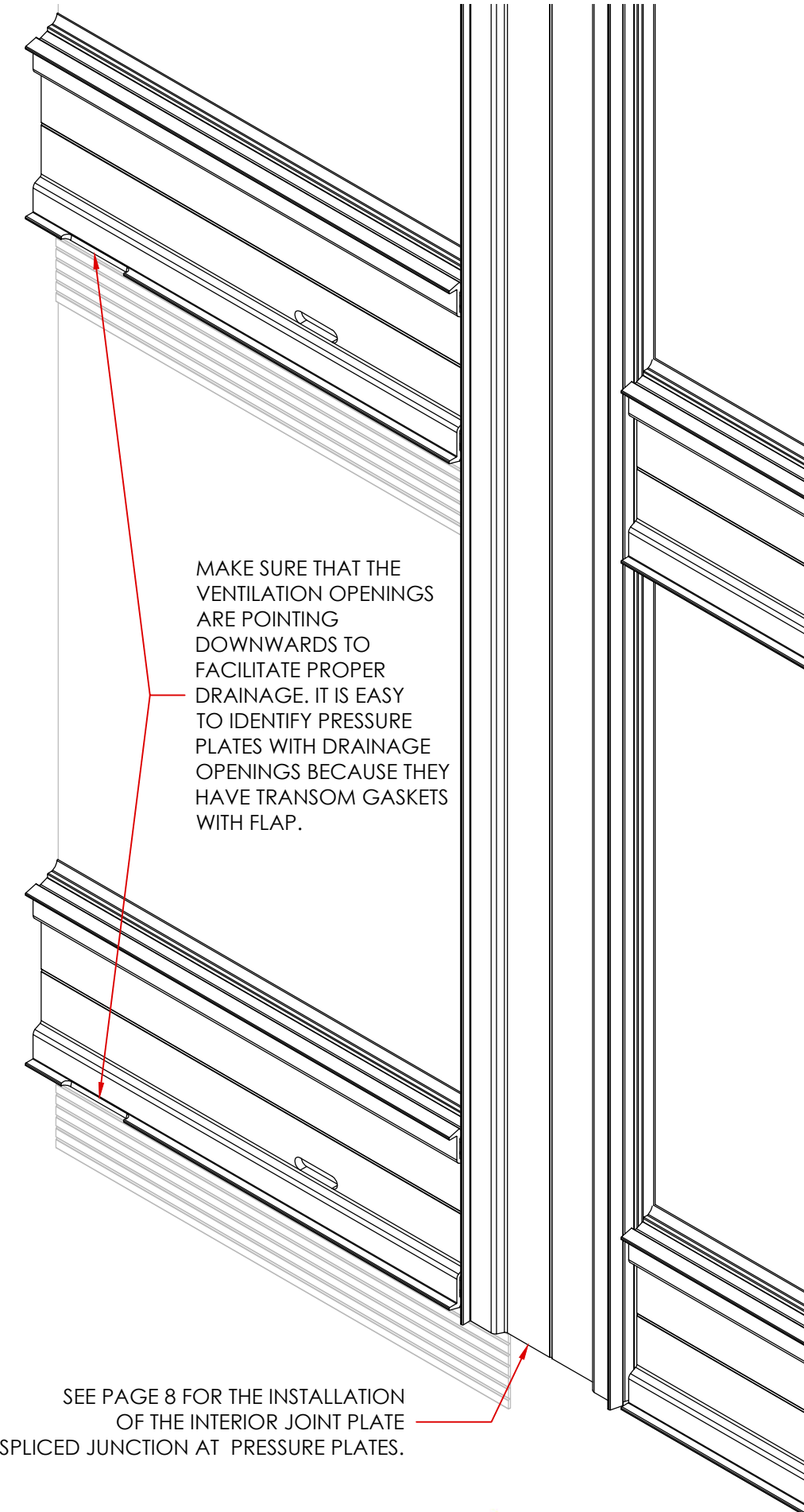

DIAGRAM 9.1: ASSEMBLY OF PRESSURE PROFILES

DIAGRAM 9.2: PRESSURE PLATES ALIGNMENT

DIAGRAM 10: PRESSURE PLATES INSTALLATION

PRESSURE PLATE INSTALLATION

EXCESS MATERIAL MUST BE REMOVED FROM TRANSOM PRESSURE PLATES THAT HAVE GASKET FLAPS. PLEASE FOLLOW INSTRUCTIONS BELOW:

- 1) IDENTIFY THE EXCESS FLAP MATERIAL TO BE REMOVED. EVERYTHING EXCEEDING THE EDGE OF THE PRESSURE PLATE SHOULD BE REMOVED.
- 2) WITH THE AID OF LONG NOSED PLIERS, CLAMP ONTO THE EXTRA MATERIAL THAT OVERHANGS THE EDGE OF THE PRESSURE PLATE. (USE THE CLOSEST RIB BELOW THE SEAL, AND DELICATELY PULL IT BACK FROM ONE SIDE TO THE OTHER ALONG THIS RIB-LINE)

RESULT FROM THE REMOVED FLAP GASKET:

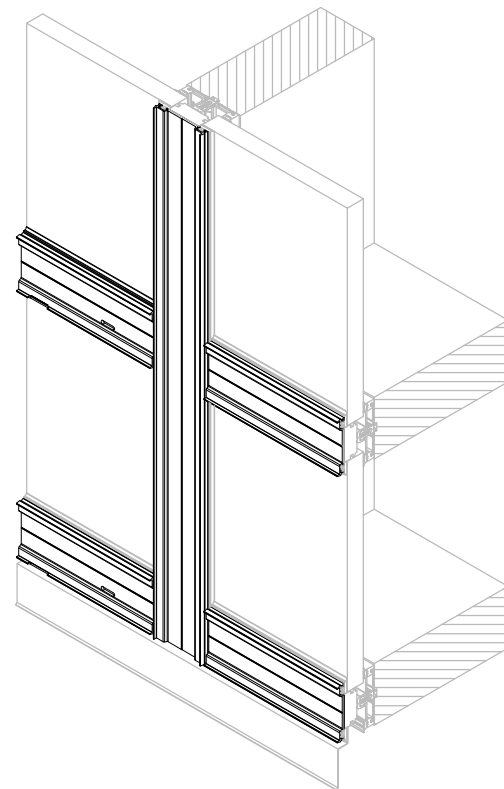

DIAGRAM 11: RESULT OF INSTALLED PRESSURE PLATES

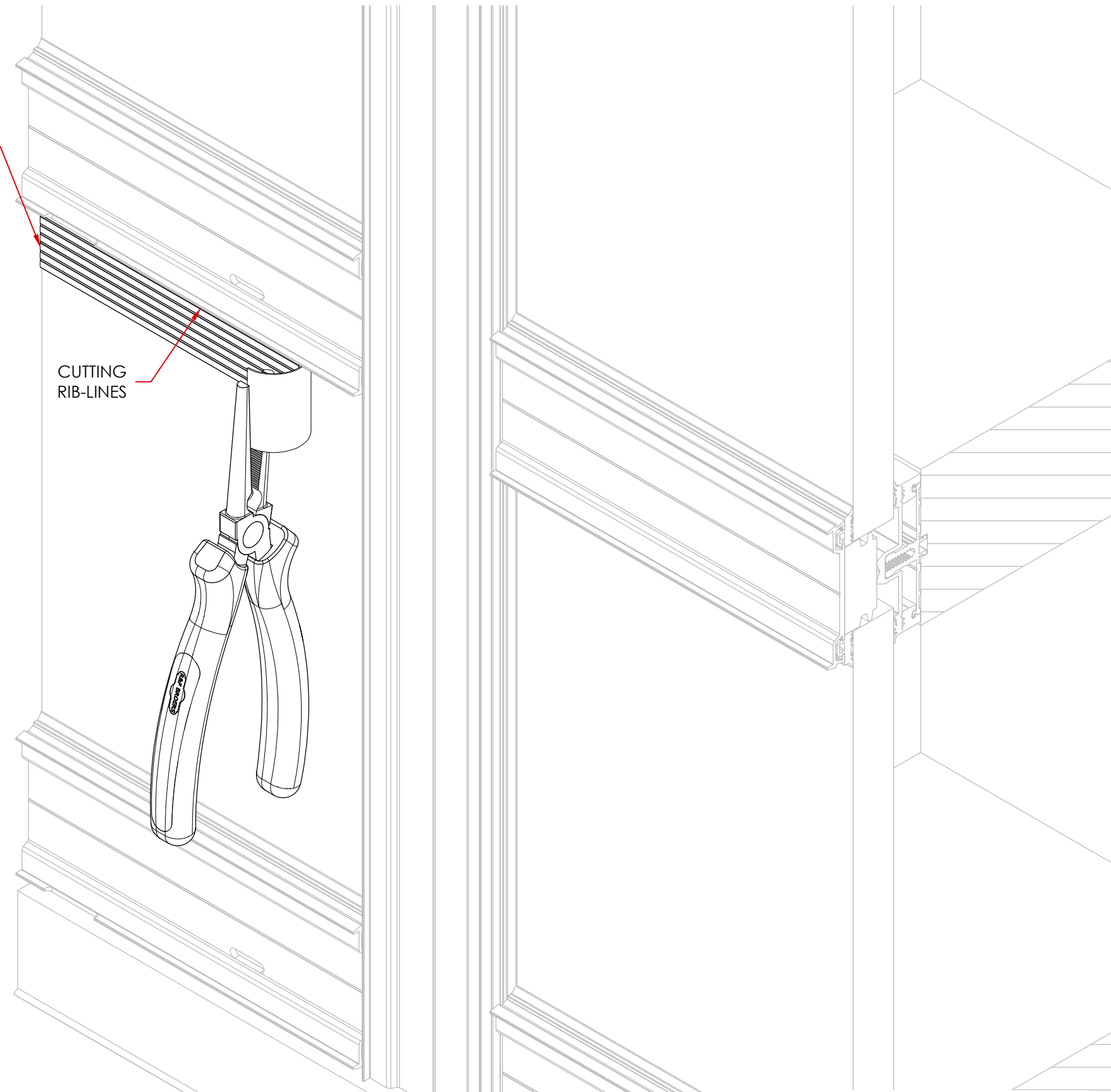

DIAGRAM 12: REMOVAL OF GASKET FLAP

CAP PROFILE INSTALLATION AND ASSEMBLY

ASSEMBLY INSTRUCTIONS:

(EXTRACT FROM RAICO'S MANUAL)

- STICK THE ***JOINT SEALING PLATE*** CENTERED BETWEEN THE GLASS SECTIONS AT THE JOINT OF PRESSURE PLATE.
- ROLL THE PRESSURE PLATE GASKET ONTO THE PRESSURE PLATE PROFILE (WHEN THERE IS A JOINT IN THE PRESSURE PLATE, BE SURE TO HAVE THE GASKET OVERLAP PAST THE JOINT 50mm)
- SEAL THE GASKET JOINT WITH SEALING COMPOUND (NO. 952015 FOR EPDM GASKETS, 952020 FOR SILICONE GASKETS).
- GLUE THE PRESSURE PLATE GASKET PIECE NO. 014035(50), 014036 (56) OR 014037(76) TO BOTH ENDS OF THE PRESSURE PLATE.
- SCREW THE PRESSURE PLATE INTO THE SCREWING CHANNEL LOCATED ON THE MULLION/TRANSOM ACCORDING TO THE RAICO SPECS AND DOCUMENTS.
- APPLY METAL GLUE TO THE INSIDE OF THE CAPS WHERE THEY WILL BE SPLICED TOGETHER. PRESS DOWN THE ***INTERIOR JOINT PLATE*** INTO THE GLUE AND ALLOW TO SET ON ONE CAP PROFILE ONLY. (LEAVE 10mm SPACE WITH GLUE AT THE END OF THE SECOND CAP, SO GLUE WONT SQUEEZE INTO THE SPLICE)
- WITH A SPACING OF 5mm BETWEEN THE TWO CAPS, PLACE THEM BOTH OVER THE PRESSURE PLATE, AND PRESS/ CLIP THEM BOTH IN.

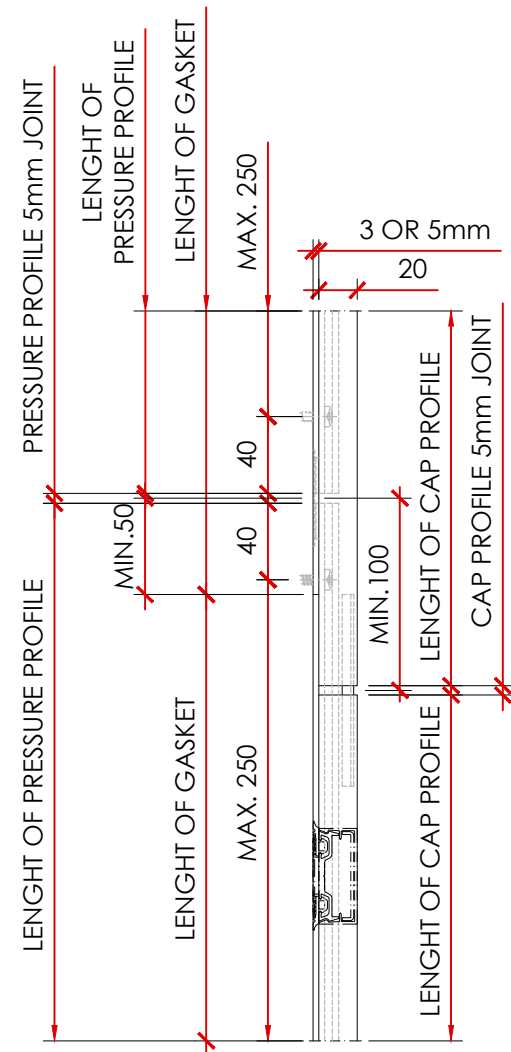

DIAGRAM 13: CLEARANCE REQUIRED OF RAICO SYSTEM

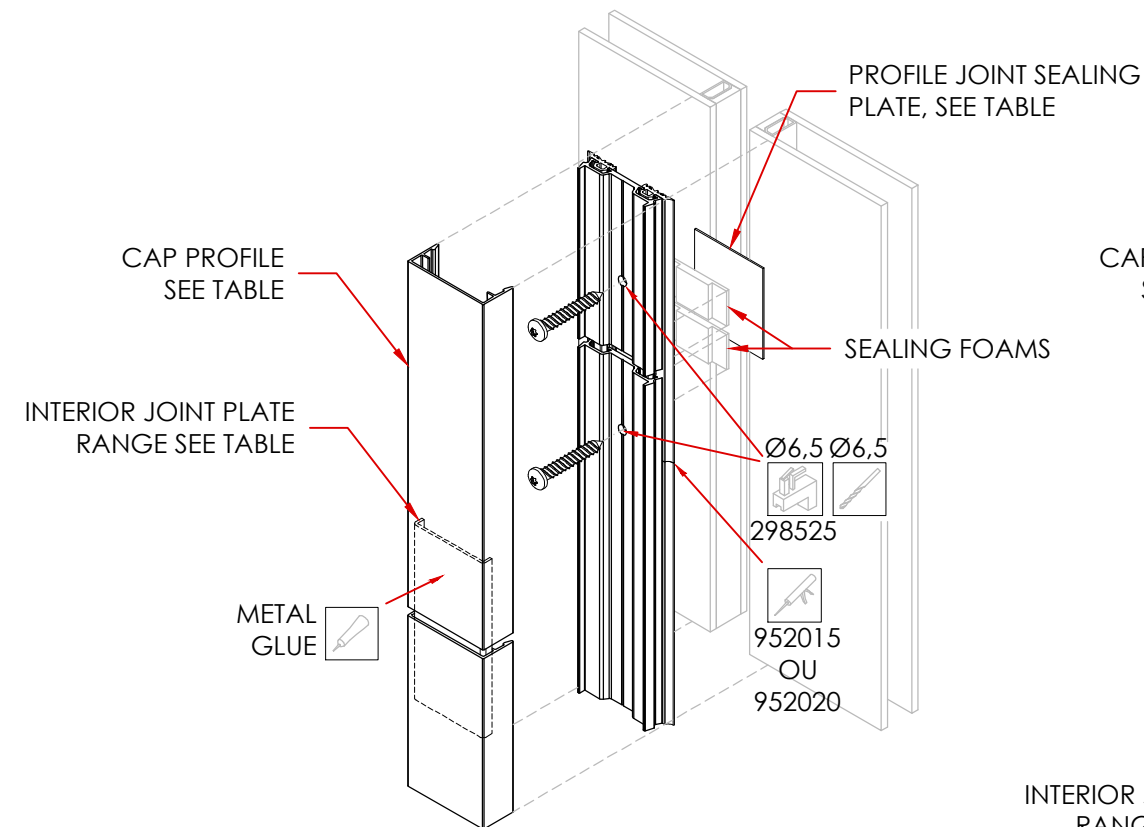

DIAGRAM 14: JOINT IN THE INTERMEDIATE RANGE

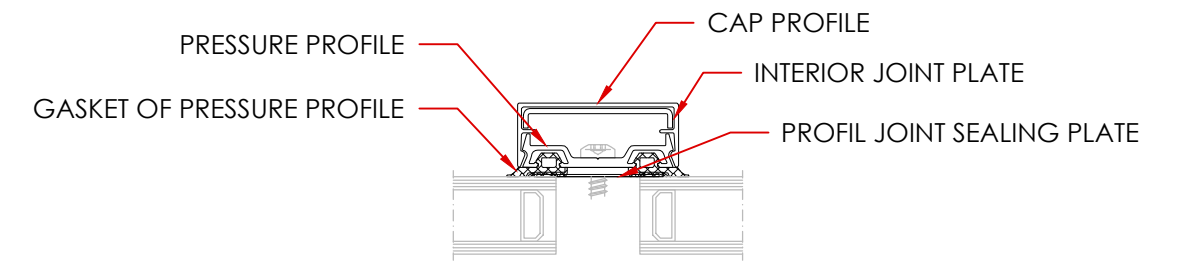

DIAGRAM 16: EXTERIOR SEALING SYSTEM

LIST OF INTERIOR JOINT PLATES AND PROFILE JOINT SEALING PLATES

CAP PROFILE	INTERIOR JOINT PLATE	PROFILE JOINT SEALING PLATE
013003 (50X15)	167230	016070
013210 (50X20)	167232	016070
141106 (50X30)	167236	016070
013023 (56X15)	167250	016071
013410 (56X20)	167252	016071
141307 (56X32)	167257	016071
013050 (76X15)	167270	016072
013610 (76X20)	167272	016072
013615 (76X25)	167274	016072
013620 (76X30)	167276	016072

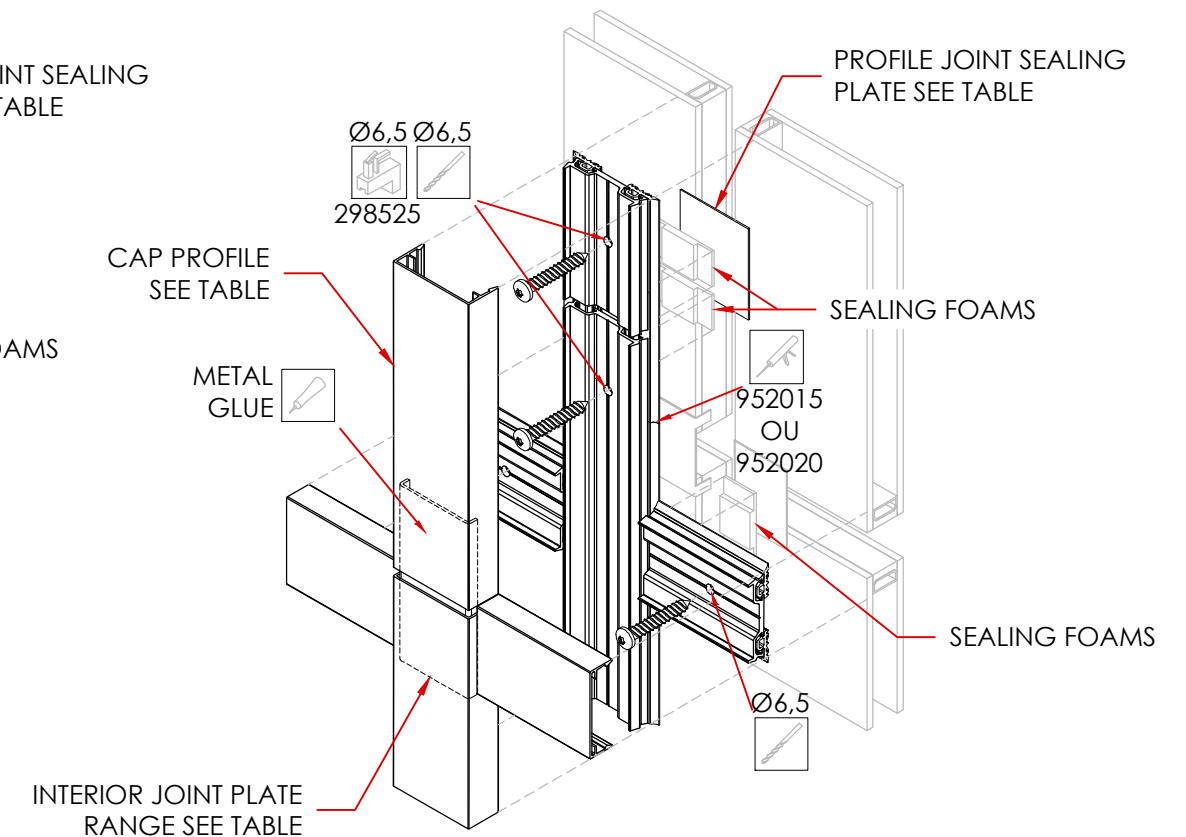

DIAGRAM 15: JOINT IN THE CROSS POINT RANGE

CAP PROFILE INSTALLATION AND ASSEMBLY

(REFER TO THE ASSEMBLY PLAN)

BELAY SHEETS INSTALLATION:

BELAY SHEETS ARE USED ON MULLION CAP PROFILES IF THE LENGTH EXCEEDS 6 METERS(19.68FT) OR IF THE CAPS HAVE A TENDENCY TO DROOP OR DEFLECT DOWNWARDS. (KEEPS THE CAP STRAIGHT AND PERPENDICULAR). BELAY SHEET PROFILES WILL BE SUPPLIED AT THE BEGINNING OF THE PROJECT, AND IT IS ALWAYS POSSIBLE TO CONTACT IC² TECHNOLOGIES INC. TO OBTAIN AN ADDITIONAL QUANTITY DURING THE INSTALLATION PROCESS.

MORE THAN 6 METER LONG CAP PROFILE:

INSTALL BELAY SHEET AT THE BASE AND THE HEAD OF THE CAP PROFILE NEAREST GROUND. PLAN 4 BELAY SHEETS FOR A MIDDLE CAP PROFILE CURTAIN WALL AND 2 BELAY SHEETS FOR PERIMETER CAP PROFILES.

CAP PROFILE WITH DOWNWARD DEFLECTION:

INSTALL BELAY SHEET ON EACH SIDE OF THE PROBLEMATIC CAP PROFILE. INSTALL THE REQUIRED NUMBER OF BELAY SHEET TO ALLOW COVER PROFILES TO BE MAINTAINED IN PLACE.

BELAY SHEET FOR RETAINING CAP PROFILE:

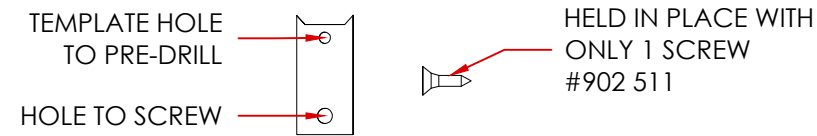

STEP 1: INSTALL VERTICAL CAP PROFILE FIRST.

STEP 2: PRESS THE BACK OF THE BELAY SHEET ONTO THE MULLION CAP PROFILE AND CENTER IT ON THE PRESSURE PLATE.

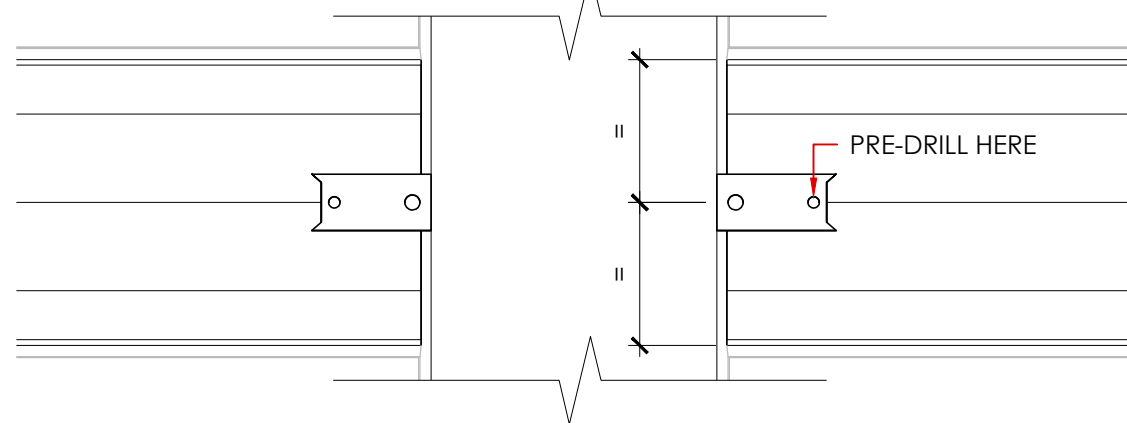

STEP 3: PRE-DRILL WITH 1/8" DRILL BIT IN THE SMALLEST HOLE (TEMPLATE HOLE).

STEP 4: ROTATE THE BELAY SHEET AND SCREW IT WITH THE SUPPLIED SCREW #902 511.

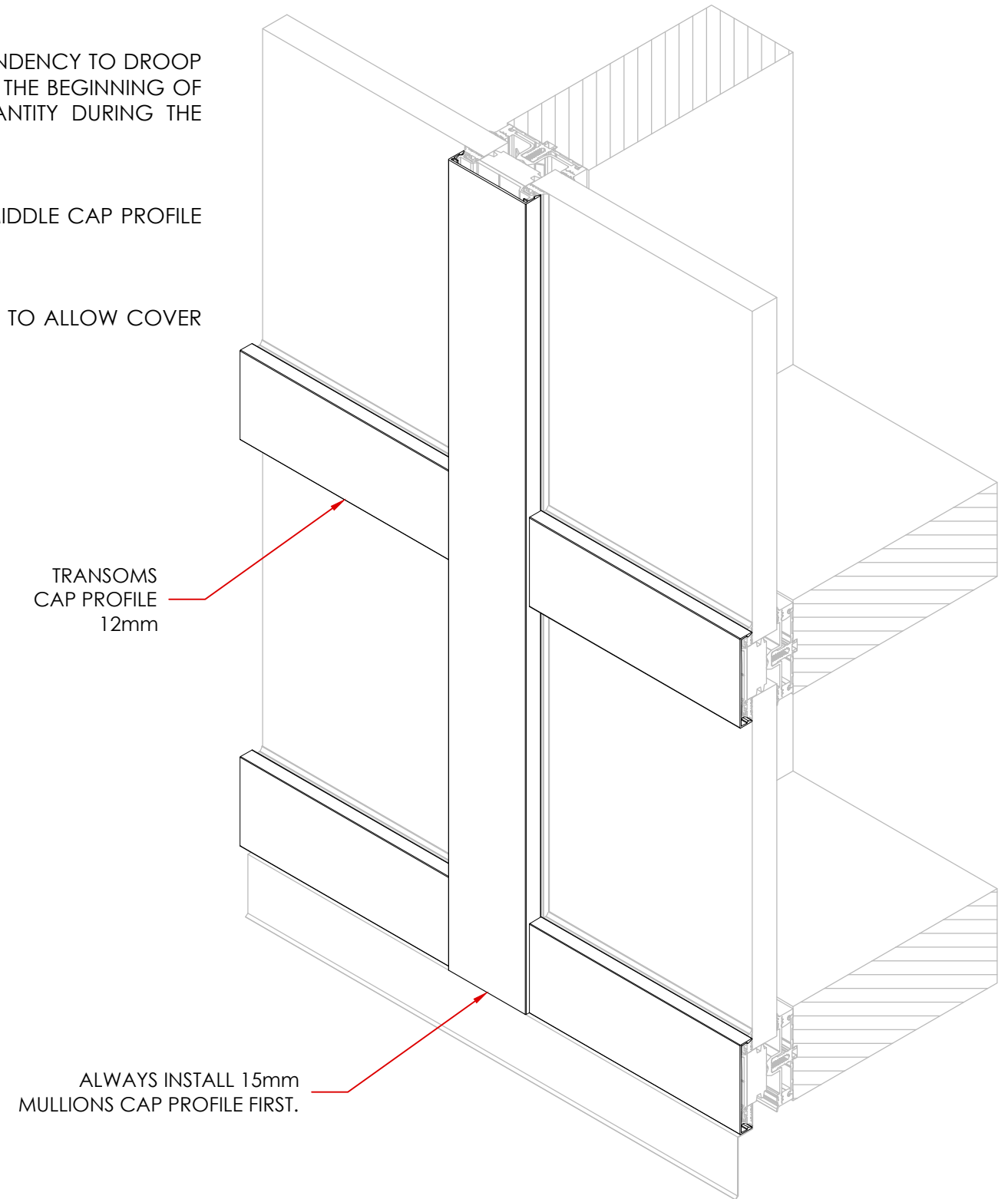
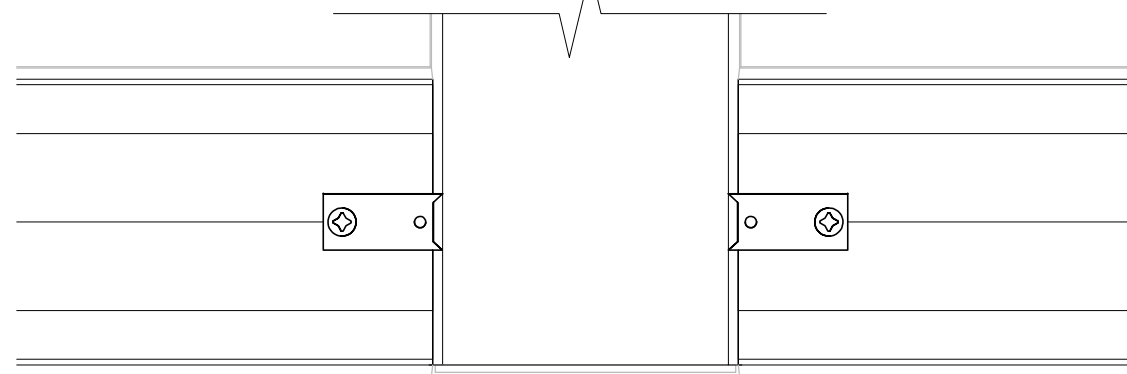

DIAGRAM 17: RESULT OF INSTALLED CAP PROFILE