



Part Number: <u>33923</u>	Revision: <u>B</u>	Effective Date: <u>5/29/12</u>	By: <u>J. INGERSLEV</u>
Document Type (indicate):			
<ul style="list-style-type: none"> ◦ Bill of Material • Assembly Instructions 	<ul style="list-style-type: none"> ◦ Drawing (may be attached) ◦ Operating Procedure 	<ul style="list-style-type: none"> ◦ Specification ◦ Other 	

Hot Rod Bike Fenders

Installation Instructions



Tools required	1
Installation Instructions	2
Front fenders	2
Rear Fenders	10
Different cut styles of Fenders	14



Tools required

- $\frac{3}{16}$ " , $\frac{1}{4}$ " , $\frac{25}{64}$ " Drill bits
- Rivnut tool

$\frac{5}{32}$ " Hex Key
White Marker
Tape measure
Jig or air saw
Drill
(2) 2x4 or similar blocks
Floor jack
Jack stands
Clamps

Installation Instructions

Front fenders

-  Before deciding the cut of the front fenders, align the front front suspension so that the fender mounts are oriented correctly.
-  See pictures of finished cars at the end of the instructions for ideas on fender trimming

Jack the front of the car up and place on jack stands.

If the front suspension is assembled, remove the front hubs and the steering arm bolts.

ITEM NO.	PART NUMBER	DESCRIPTION	With Bike Fender mount/QTY.
1	33043	SPINDLE - Hot Rod Driver/Roadster Passenger	1
2	33045	33045 - HOT ROD STEERING ARM, DRIVER SIDE	1
3	FRONT HUB		1
4	B18.2.2.4M - Hex flange nut, M20 x 2.5 -N		1
5	33635 - FRONT BIKE FENDER MOUNT	FRONT BIKE FENDER MOUNT	1
6	B18.2.3.5M - Hex bolt M12 x 1.75 x 1.20 -30N		2
7	33652	0.675" SPACER	2
8	B18.2.2.4M - Hex flange nut, M12 x 1.75 -N		2

REVISIONS			
REV.	DESCRIPTION	DATE	APPROVED
A	INITIAL RELEASE	4/10/12	

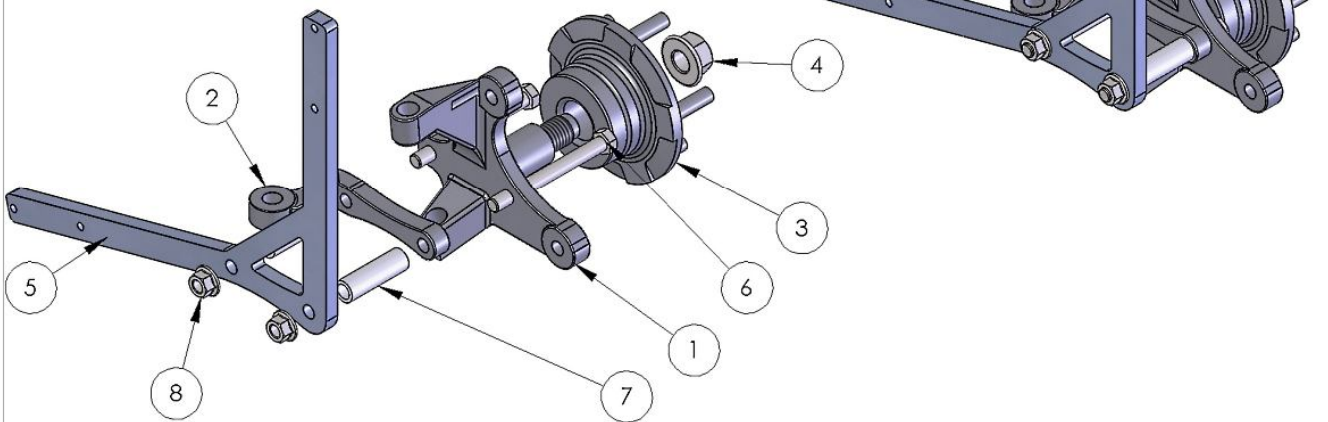

UNLESS OTHERWISE SPECIFIED:		NAME	DATE
HOT ROD	DIMENSIONS ARE IN INCHES	JI	3/3/08
	TOLERANCES:	COMMENTS:	
	TWO PLACE DECIMAL ±0.01		
	THREE PLACE DECIMAL ±0.005		
	FOUR PLACE DECIMAL ±0.001		
	MATERIAL		
	FINISH		
USED ON			
APPLICATION		PRINTED	4/10/2012

PROPRIETARY AND CONFIDENTIAL
THE INFORMATION CONTAINED IN THIS DRAWING IS THE SOLE PROPERTY OF FACTORY FIVE RACING, INC. ANY REPRODUCTION IN PART OR AS A WHOLE WITHOUT THE WRITTEN PERMISSION OF FACTORY FIVE RACING, INC. IS PROHIBITED.

Factory Five Racing, Inc.

TITLE:
DRIVER SIDE SPINDLE ASSEMBLY

SIZE **A** DWG. NO. **Hot Rod Driver side Spindle** REV **A**

SCALE: 1:4 WEIGHT: SHEET 2 OF 2

Install the long steering arm bolts, spacers and front fender mount bracket. Leave the locknuts loose for now.

Reattach the wheel.



Clamp the fender to the mount so that the fender is between the tire and mount and is positioned around the tire as desired.



It is recommended to keep the fender low in the back so that any stones or sand that is thrown up is kept to a minimum.

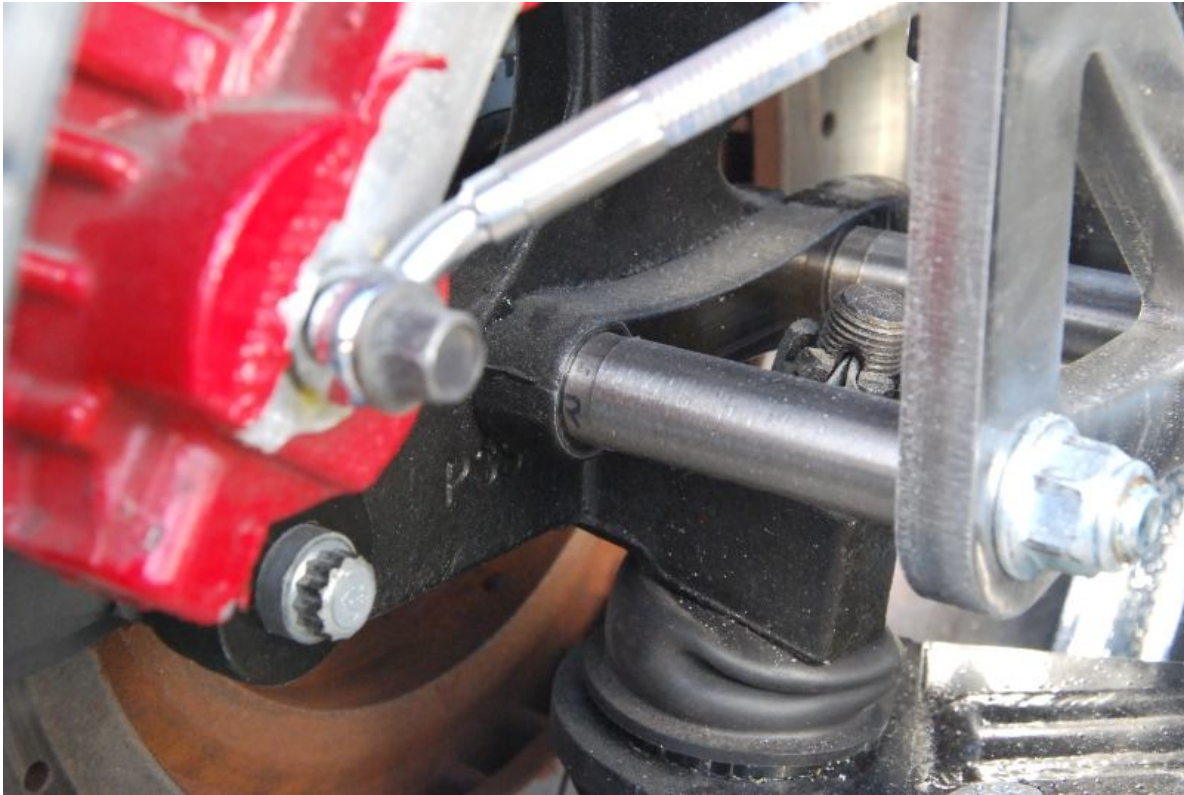

Depending on how the fender is trimmed and the look desired, if necessary add shims to the fender mount so the fender is centered on the tire.

Mark the fender as desired for trimming.



Make sure that there is at least a hand clearance between the fender and tire at all positions under the fender.



Use the fender mount holes as a guide to mark the 1/4" bolt holes in the fenders using a 1/4" drill bit.
Remove and trim the fenders.

Drill the ¼” mounting holes.



Reclamp the fender in place using the ¼” mounting screws to locate the fender.

Insert the screws into the mount holes and make sure the screws do not hit the wheel or tire.
Remove the wheel.

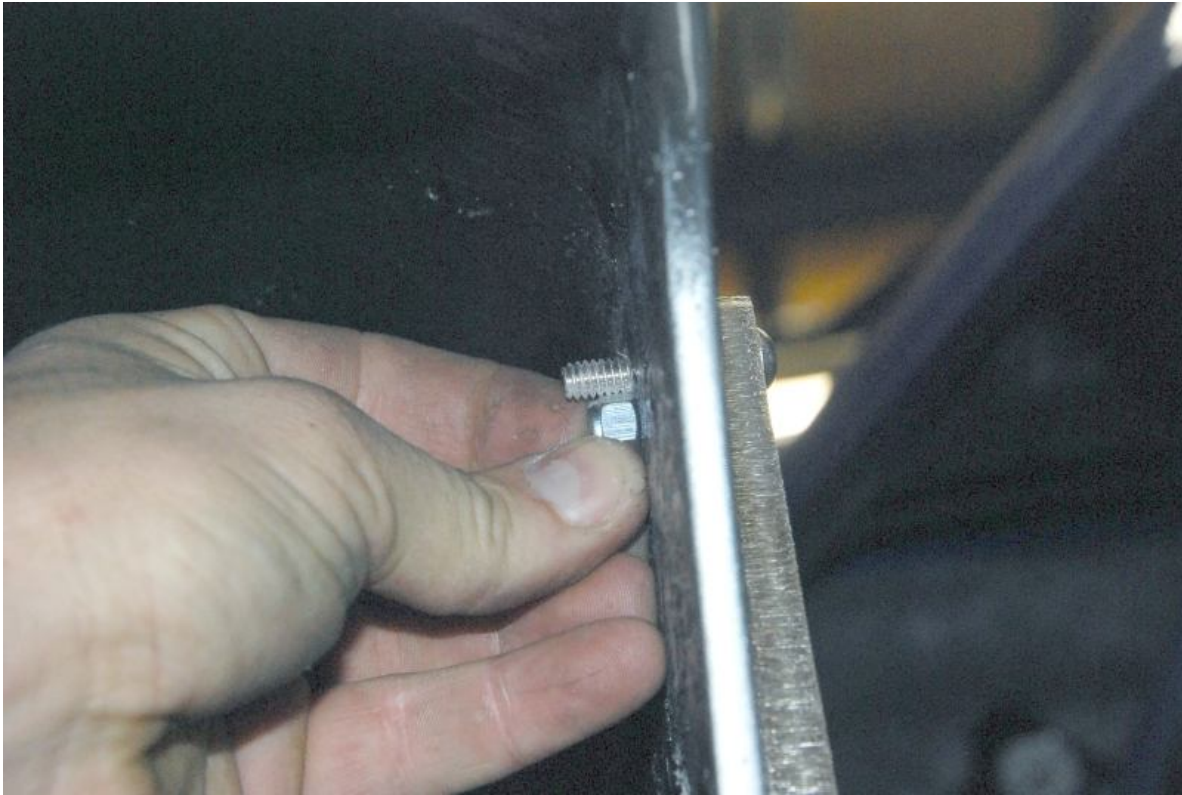

Check to make sure that the screw will go completely through the locknut. If necessary remove material from the fender.



Attach the fender to the mount.

Remount the wheel.



Recheck clearance between the fender and tire.

Remove the fenders for painting.

Rear Fenders



See pictures of finished cars at the end of the instructions for ideas on fender trimming

Place the rear of the car on jack stands and remove the rear wheel.



Position the rear fender on the body so it fits tight on the inside, hold it in place with a 2x4 on a jack stand or similar.





Mark and trim the fender as desired.

Position the fender on the body making sure the inside flange tight against the body.



Drill a $\frac{3}{16}$ " hole straight up making sure it goes through the fender and the body.

Enlarge the hole to $\frac{1}{4}$ ".



Remove the fender and enlarge the hole in the body to $\frac{25}{64}$ ".

Install a rivnut in the body.

Remount the fender this time using a $\frac{1}{4}$ "-20 flange head bolt to hold the fender in place.

Move 6" towards the front of the fender and repeat the process; drill a $\frac{3}{16}$ " hole through the fender and the body.

Enlarge the hole to $\frac{1}{4}$ ".

Remove the fender and enlarge the hole in the body to $\frac{25}{64}$ ".

Install a rivnut in the body.

Remount the fender with two screws.

Once two screws have been mounted the remaining $\frac{1}{4}$ " holes can be drilled without having to remove the fender after each one.

Install remaining mounting rivnuts.

Trim the fender using an air saw or jig saw.

Attach the fender to the body.

Attach the wheel to the axle.



Jack the rear end up so that it is at ride height and check the fitment of the wheel in the fender. Make sure there is no interference.

Remove the fenders for paint

Different cut styles of Fenders



