

Installation Instructions
for
Digital Pressure gauge
Series MAN-SD

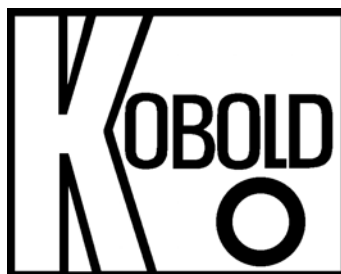

1. Instructions

Please read this service manual carefully before unpacking and setting the unit for operation, and follow the instructions precisely as described herein.
These devices may only be installed, used and maintained by skilled personnel who are familiar with this service manual and can observe applicable regulations regarding industrial safety and accident-prevention.

2. Contents

| | |
|--------------------------------|----|
| 1. Instructions | 3 |
| 2. Contents | 3 |
| 3. General..... | 3 |
| 4. Mechanical Connection | 4 |
| 5. Electrical Connection..... | 5 |
| 6. Function Keys..... | 6 |
| 7. Programming/Setup | 6 |
| 8. Control Functions | 7 |
| 9. Technical Data | 11 |

Kobold Instruments, Inc
1801 Parkway View Drive
Pittsburgh, PA 15205
Ph: 412-788-2830
FAX: 412-788-4890
E-mail: info@koboldusa.com
www.koboldusa.com

3. General

The KOBOLD MAN-SD series digital pressure gauge employs a ceramic strain gauge type sensing element to detect process system pressure. The signal from the strain gauge is sent to signal processing electronics to convert the signal into a pressure reading.

The series MAN-SD offers the following user features:

- 4-Digit LCD Display
- Three Programming Keys
- Process Connection (St. Steel)
- Power Supply via 9V block battery
- Limit Relay (option)
- Peak Hold (option)
- Analogue Output (option)
- Auto-Shutoff (option)

4. Mechanical Connection

Before installation:

- Ensure that the max. pressure in your system is within the measuring range of the pressure gauge. The measuring range can be found on the labeling.
- Ensure that the permitted max. operational temperature of device is not exceeded.

Installation:

- Ensure that the piping is depressurized or that the pressure gauge connection is adequately isolated from system pressure.
- The digital pressure gauge mechanical installation is the same for that as mechanical pressure gauges.
- With standard thread connection, sealing is achieved by use of an appropriate thread sealant which will withstand the operating temperature and chemicals which it may come in contact with.
- When installing the pressure gauge into the fitting always use an appropriately sized wrench (24mm) on the hex nut at the base of the housing. Never use the housing to screw the gauge into the fitting. Damage to the housing will result.
- If possible check after the mechanical installation to ensure that it is properly sealed.

5. Electrical Connection

Attention! Please ensure that the voltage of your power supply corresponds with the admissible voltage level for this device.

- Review the electrical specifications in section 9. Ensure that the electrical limits of the device are not exceeded. (applies to relay or analog output option)
- Open the battery enclosure on the back-side of the unit and connect the 9V block battery with the connection plug.
- Place the 9V block battery in the enclosure and close it with the lid.
- Terminate the connection wires on the plug (cable), as shown in the illustration below (applies to relay or analog output options).

Warning! A wrong connection can result in the destruction of device's electronics.

| Cable No. | Relay Option | Analog Output Option |
|-----------|----------------------------|------------------------------------|
| 1 | | |
| 2 | Contact output (Relay in) | |
| 3 | | GND (0V Reference) |
| 4 | | Analogue output 0-2V _{DC} |
| 5 | Contact output (Relay out) | |

Plug M12x1

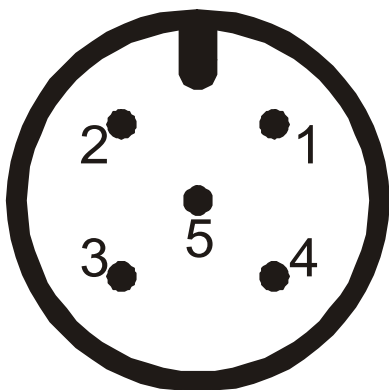

View of plug contacts

5-core cable

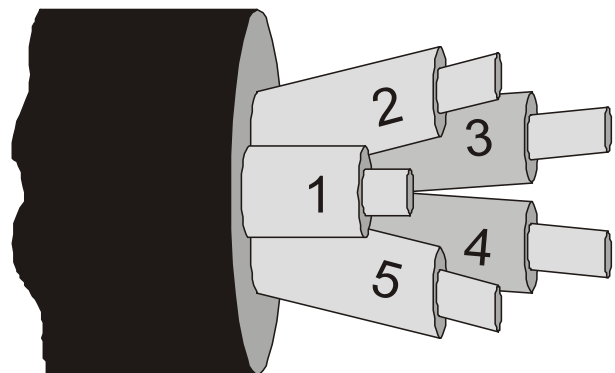

cable wires with numbers

6. Function Keys

For the selection of menu options, the following functions keys are available:

- ↓ **Next Menu Option**
- ↑ **Previous Menu Option**
- P **1 x operate Switch-on**
- P **2 x operate Switch-off**
- P & ↓ **Jump to Next Function**

Adjustment and Function:

- ↓ **Value-adjustment upwards**
- ↑ **Value-adjustment downwards**
- P **Confirm input for next Menu Option**
- ↑&↓ **Reject input, Return to Menu Option**

7. Programming/Setup

The following parameters are user programmable:

1. Zero point
2. Password (factory preset: 0005)
3. Peak value memory (option)
4. Relay setpoint and Hysteresis (option)
(factory preset: switching point on 50% of measuring range)

Factory presets (not user programmable):

1. Battery symbol on: voltage under 7 V
2. Switch-off time (default: 0 = inactive)
3. Sampling rate (default: 5 measurements per second)
4. Analogue output (linear) within measuring range (option)

8. Control Functions

8.1 Standard version and unit with analog output option A1

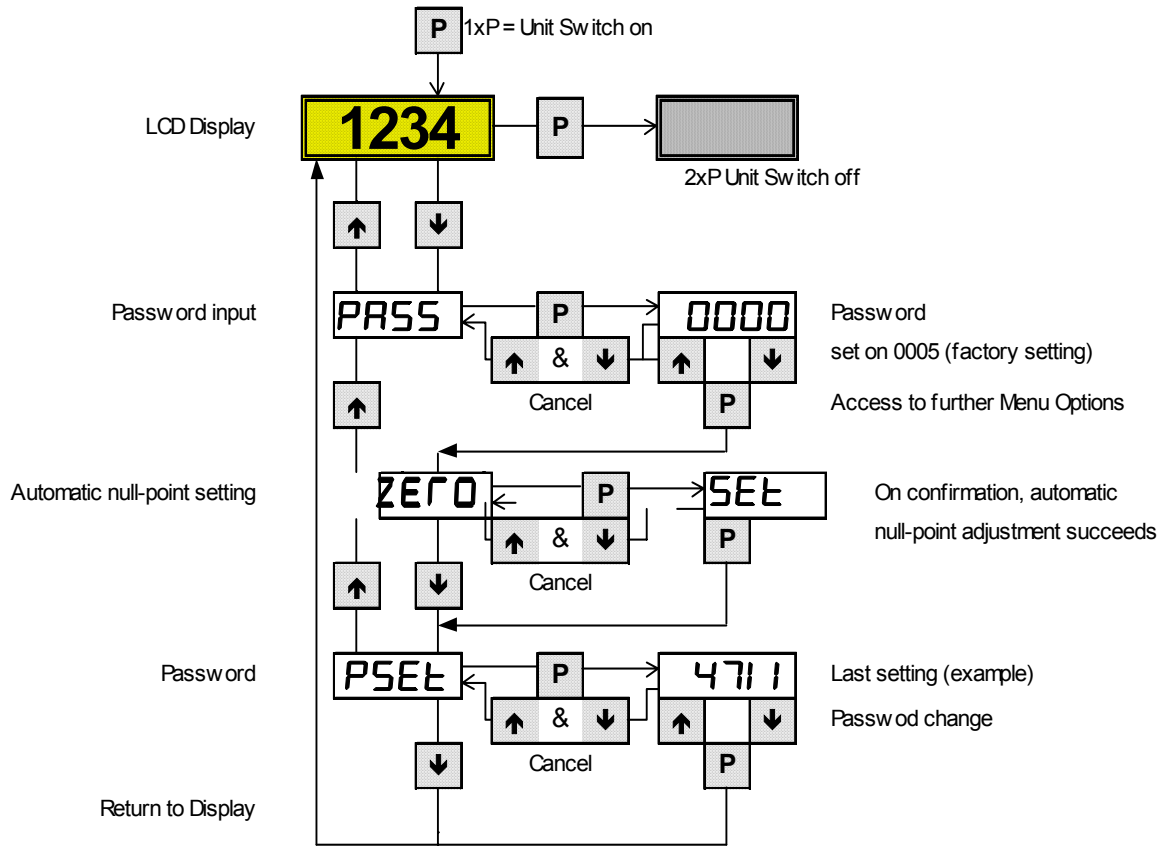

10.2 Unit with peak hold option and unit with peak hold option + analog output option

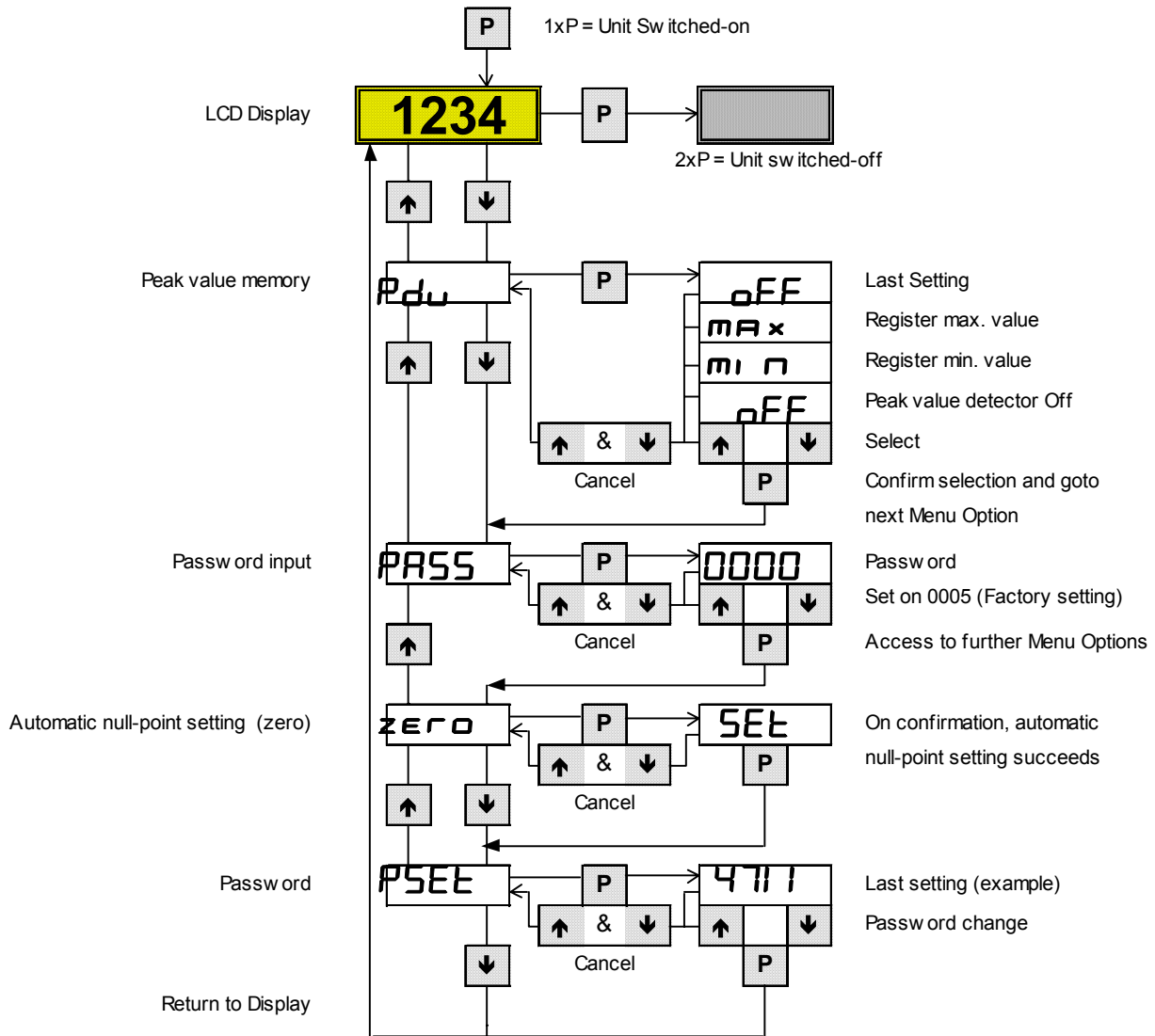

10.3 Unit with relay option

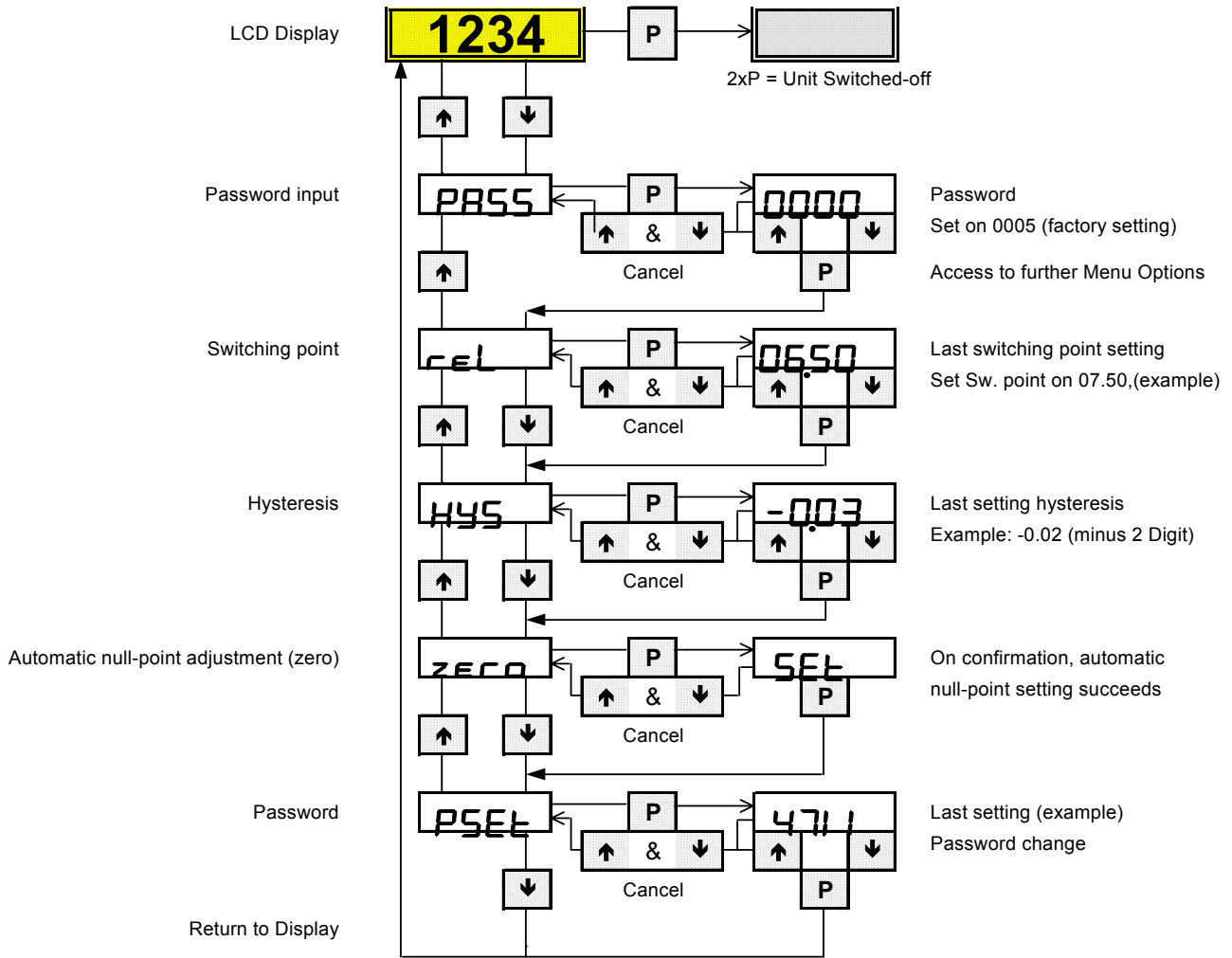

10.4 Unit with relay option + peak hold option

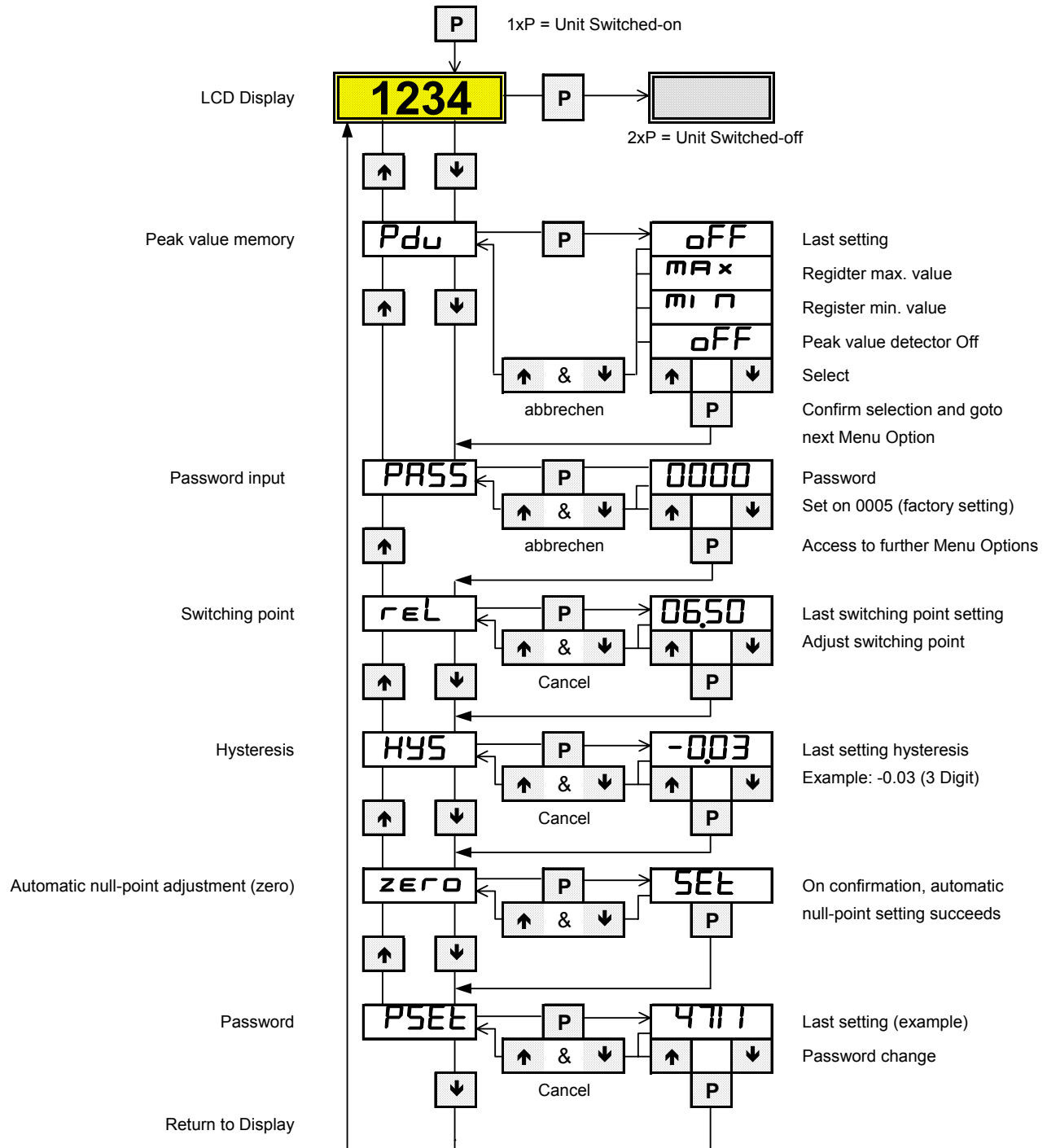

9. Technical Data

| | |
|---|--|
| Nominal size: | 74 mm |
| Accuracy: | 0.5% of full scale value |
| Display: | 4-digit LCD; digit height 12.7 mm |
| Measuring range: | 0-30" Hg Vacuum to 0-6000 PSIG |
| Overload range: | 3 x range (upto 500 PSIG) 2 x range (>500 to 3000 PSIG) 1,5 x range (>3000 to 6000 PSIG) |
| Power supply: | 9 VDC (lithium battery included) |
| Battery Life: | 5000 h (alkaline battery 600mAh), 10000 h (Lithium blockbattery 1200 mAh) |
| Sampling rate: | 5 per Sec. (standard) |
| Auto-Shutoff times: | 4, 8, 16, 32 or 64 minutes |
| Zero (tare) function: | $\leq \pm 25 \%$ |
| Parts in contact with medium: | 316 SS, Ceramic, Buna-N |
| Connection: | 1/4" NPT (Option) |
| Medium temperature: | -20 to 185°F |
| Ambient temperature: | 32 to 140°F |
| Storage temperature: | -20 to 140°F |
| Permissible relative humidity: | <90%, not condensing |
| Protection cat.: | NEMA 4X/ IP 65 |
| Limit-value relay (Option): | N/O programmable setpoint and hysteresis |
| Max. switching power: | Max. 230 VAC/220 VDC @ 50 VA Max > 2 amps @30 VDC |
| Analogue output (Option): | 0 - 2 VDC |
| Load: | $\geq 100 \text{ k}\Omega$ |
| Electrical connection (for Relay or analogue output) | Plug M12 x 1 or 0.5m cable |
| Peak value memory (Option): | Min or Max value, Resetting via keypad |

10. Dimensions

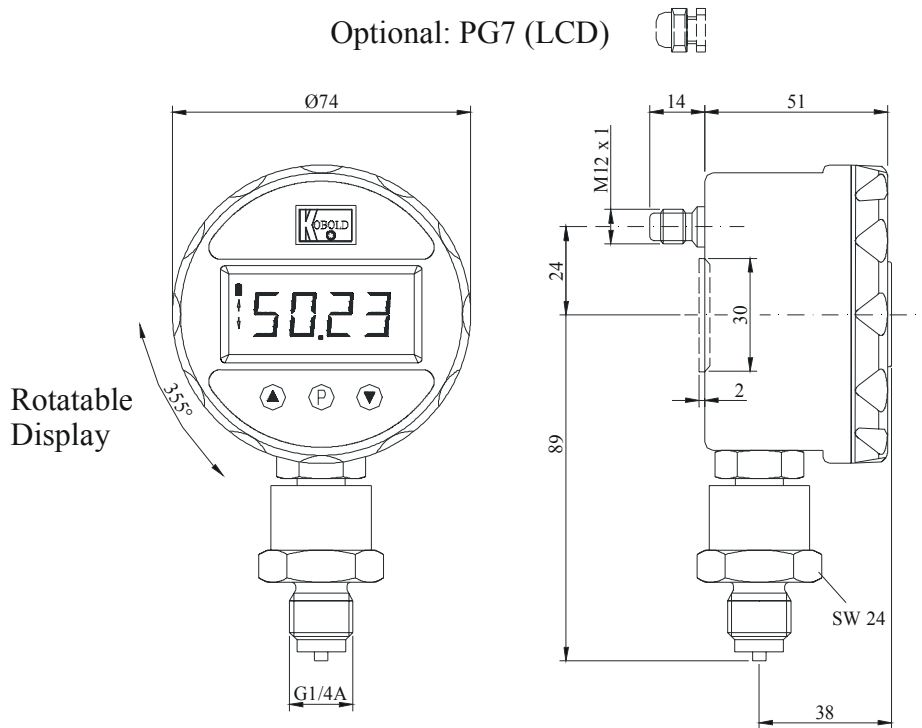

11. Model Codes

| Range | Model Number |
|-----------------|--------------------|
| 0-30" Hg Vacuum | MAN-SD-5001 |
| 0-20 PSIG | MAN-SD-5002 |
| 0-50 PSIG | MAN-SD-5005 |
| 0-100 PSIG | MAN-SD-5010 |
| 0-200 PSIG | MAN-SD-5020 |
| 0-500 PSIG | MAN-SD-5050 |
| 0-1000 PSIG | MAN-SD-5100 |
| 0-2000 PSIG | MAN-SD-5200 |
| 0-3000 PSIG | MAN-SD-5300 |
| 0-6000 PSIG | MAN-SD-5600 |

| Option Code | Description |
|--|---------------------|
| A4 | 0-2 V analog output |
| Auto shutoff (not available with relay or analog output) | |
| B08 | 8 minutes |
| B16 | 16 minutes |
| B32 | 32 minutes |
| B64 | 64 minutes |
| R | N/O relay |
| P | Peak Hold |
| OR2 | Viton Seal |
| OR3 | EPDM Seal |

12. Declaration of Compliance

We, Kobold-Messring GmbH, Hofheim-Ts., Federal Republic of Germany, declare, that the product

Digital Manometer Type: MAN-SD...

complies with the standards given below:

EN 50081-1.2.1994.03

Electromagnetic compatibility - Generic emission standard

EN 50082-2.1996.02

Electromagnetic compatibility - Generic emission standard

EN 61010-1.1994.03

Safety requirements for electrical measurement, control, and laboratory use

Also, following EWG guidelines are fulfilled:

89/336/EWG

Signature:



H. Peters

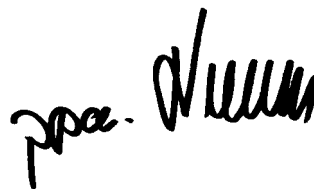

M. Wenzel

Date: 29.11.00

