



# Sprint Top

## Installation Instructions

For: Jeep Wrangler TJ  
1997 – 2006

### Part Number: 56840



#### Installation Tips

##### For a smooth fit:

For easier installation, the top should be installed at a temperature above 72° F. Below this temperature, the fabric may contract an inch or more, making it difficult to fit the vehicle.

It is normal for the fabric to contract and wrinkle when stored in the shipping carton. Within a few days after installation, the fabric will relax and the wrinkles will disappear.



### WARNING

This product is designed to enhance the appearance of the vehicle. Do not rely in any way on the components of this product to contain occupants within the vehicle, or to protect against injury or death in the event of an accident. Never operate vehicle in excess of manufacturer's specifications.

#### WEAR SEAT BELTS AT ALL TIMES

Read and follow, precisely, all installation instructions provided when installing this product. Failure to do so could place occupants of the vehicle in a potentially dangerous situation. After installing or reinstalling, check to make sure it has been properly installed.



### CAUTION

Safety glasses should be worn at all times while installing this product.

#### Tools Needed

Safety Glasses	Drill with 1/8",
Phillips Screwdriver	4.5mm & 3/16" Bits
Utility Knife	T15 Torx



**!STOP! Do not proceed unless you have a Factory Original Soft Top or Supertop NX already installed.**  
**You will need these parts to complete the Sprint Top installation**  
These Parts Are Not Included

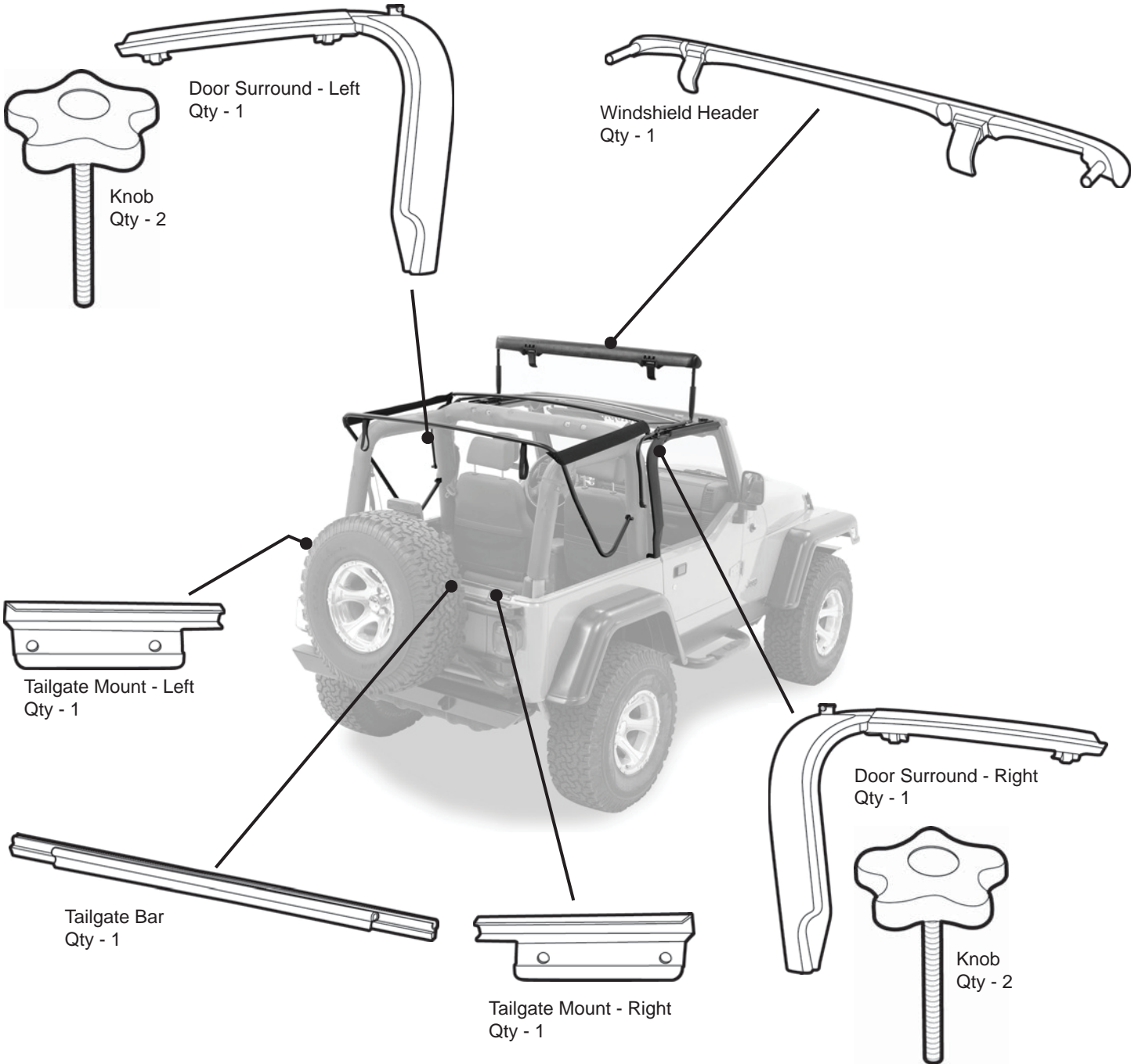

If you do not have these parts, they are available for purchase separately from an authorized Bestop distributor.  
5501201 SURROUND, TJ DOOR KIT RT & LT (w/ Tailgate Bar)  
5501401 HEADER, TJ OE REPLACEMENT

## Parts List - These Parts Are Included

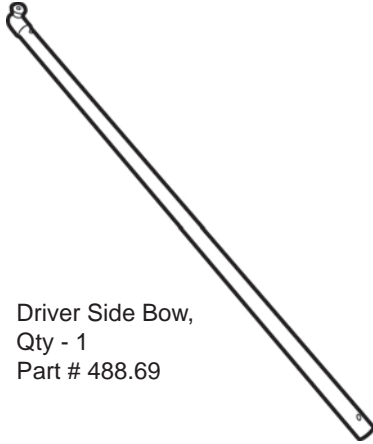

Driver Side Bow,  
Qty - 1  
Part # 488.69

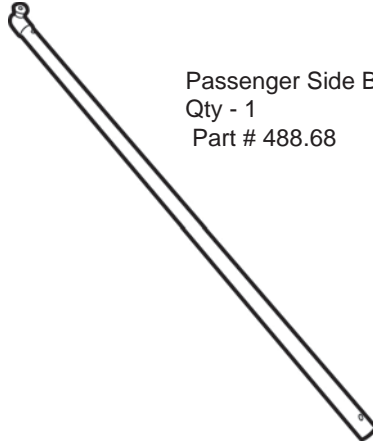

Passenger Side Bow,  
Qty - 1  
Part # 488.68



#12 x 3/8" Pan  
Head Zinc Screw,  
Qty - 4,  
Part # 309.73

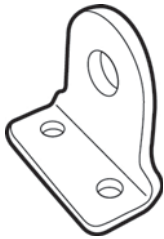

Pivot Bracket,  
Qty - 2,  
Part # 488.37



M4 x 15mm Button  
Head Torx Screw,  
Qty - 4,  
Part # 494.03

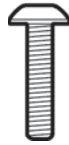

Rear Bow,  
Qty - 1  
Part # 502.44



M4 Nut Plate,  
Qty - 2,  
Part # 474.96

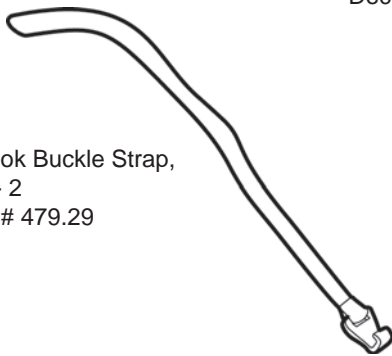

J-Hook Buckle Strap,  
Qty - 2  
Part # 479.29

Deck, Header Assembly, & Fabric Top

Right Side Window

Left Side Window

Rear Window



## Section 1 Remove Side and Rear Windows

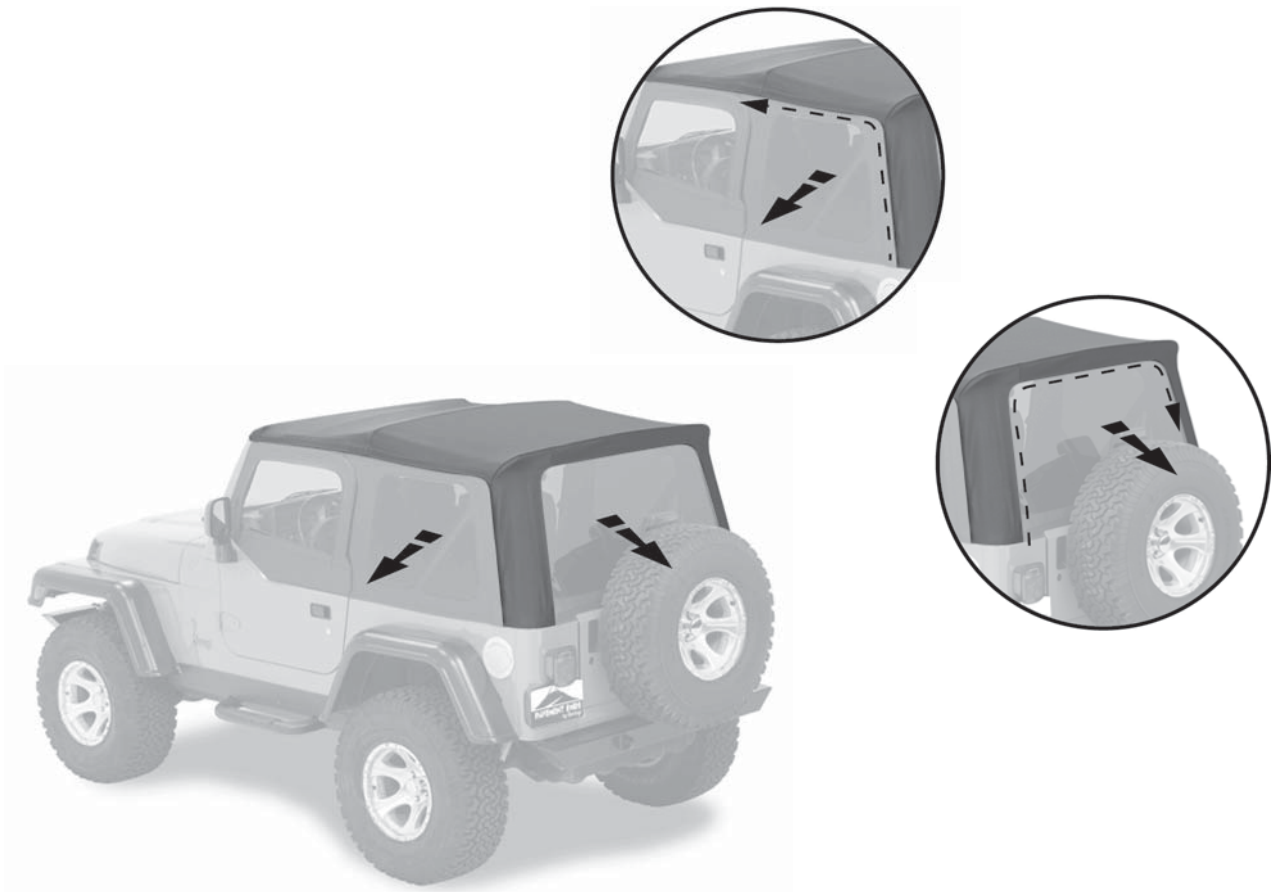

### Step One

Remove Side Windows and Rear Window.



## Section 2

## Remove Fabric and Side Bows from Header

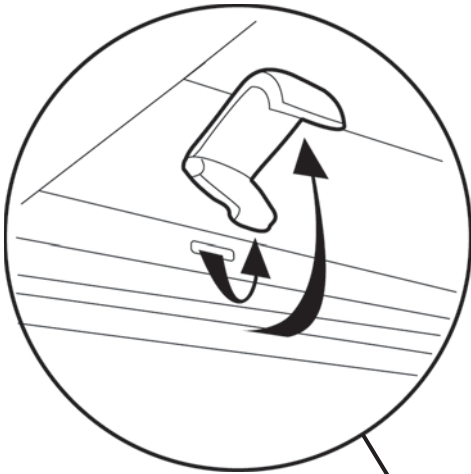

### Step One

Release the latch that secures the header to the windshield. Pull up on the lever and then down and out to release the hook from the slot in the windshield frame

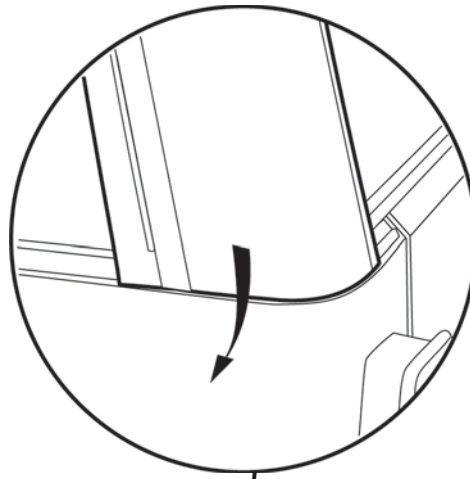

### Step Two

Release the rear corners of the top. Pull gently down and then out to release the plastic strip from the retainer on the vehicle.

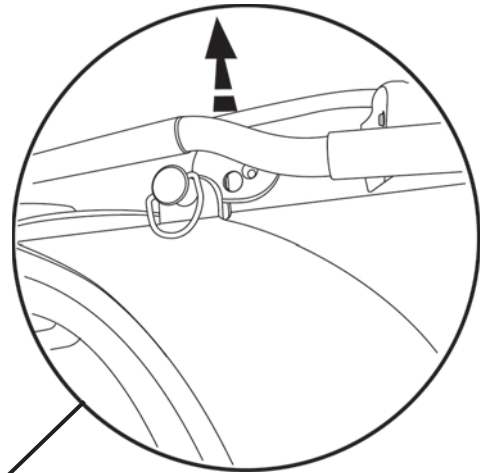

### Step Three

Release the Side Bow from the Door Surround.

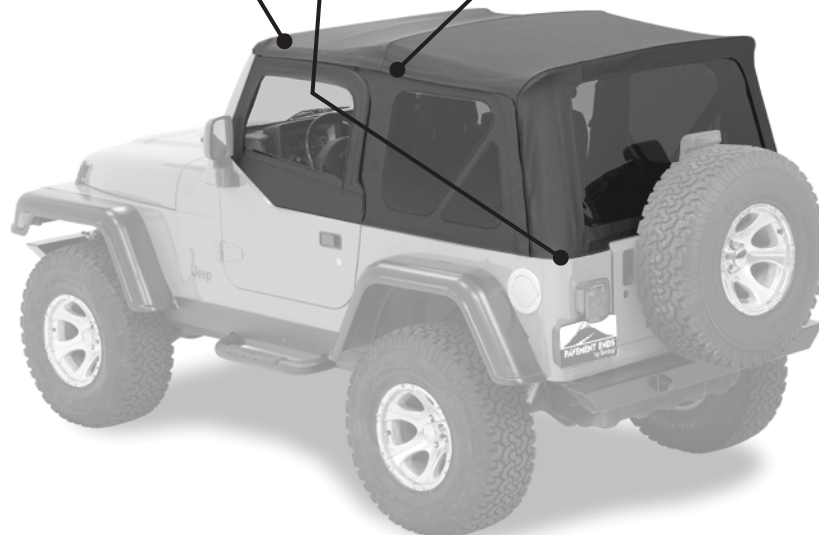



## Section 2

## Remove Fabric and Side Bows from Header (cont.)

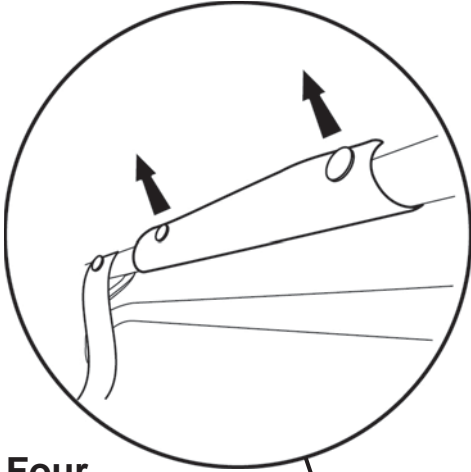

### Step Four

Release Snaps from Rear Bow.

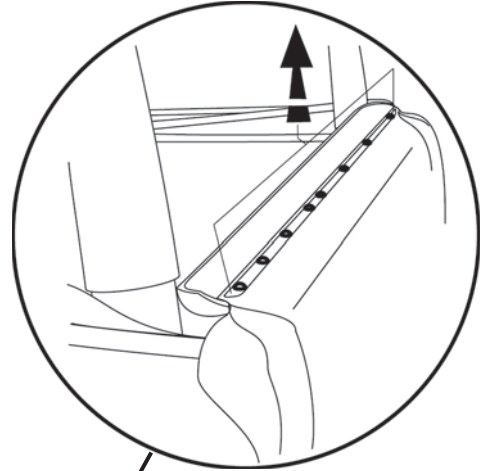

### Step Six

Remove screws that secure fabric to header.

Set screws aside to be used later.

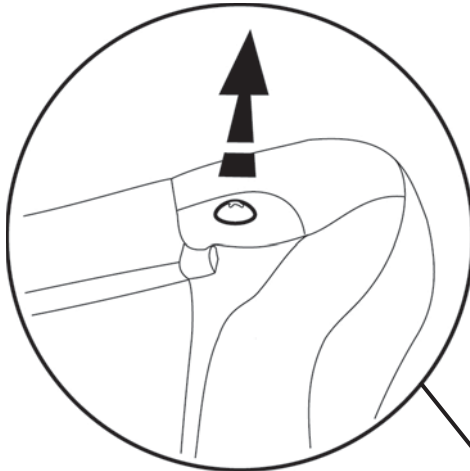

### Step Five

Remove screws that secure fabric to corners of header assembly.

Set screws aside to be used later.



## Section 3 Remove and Store All Bows

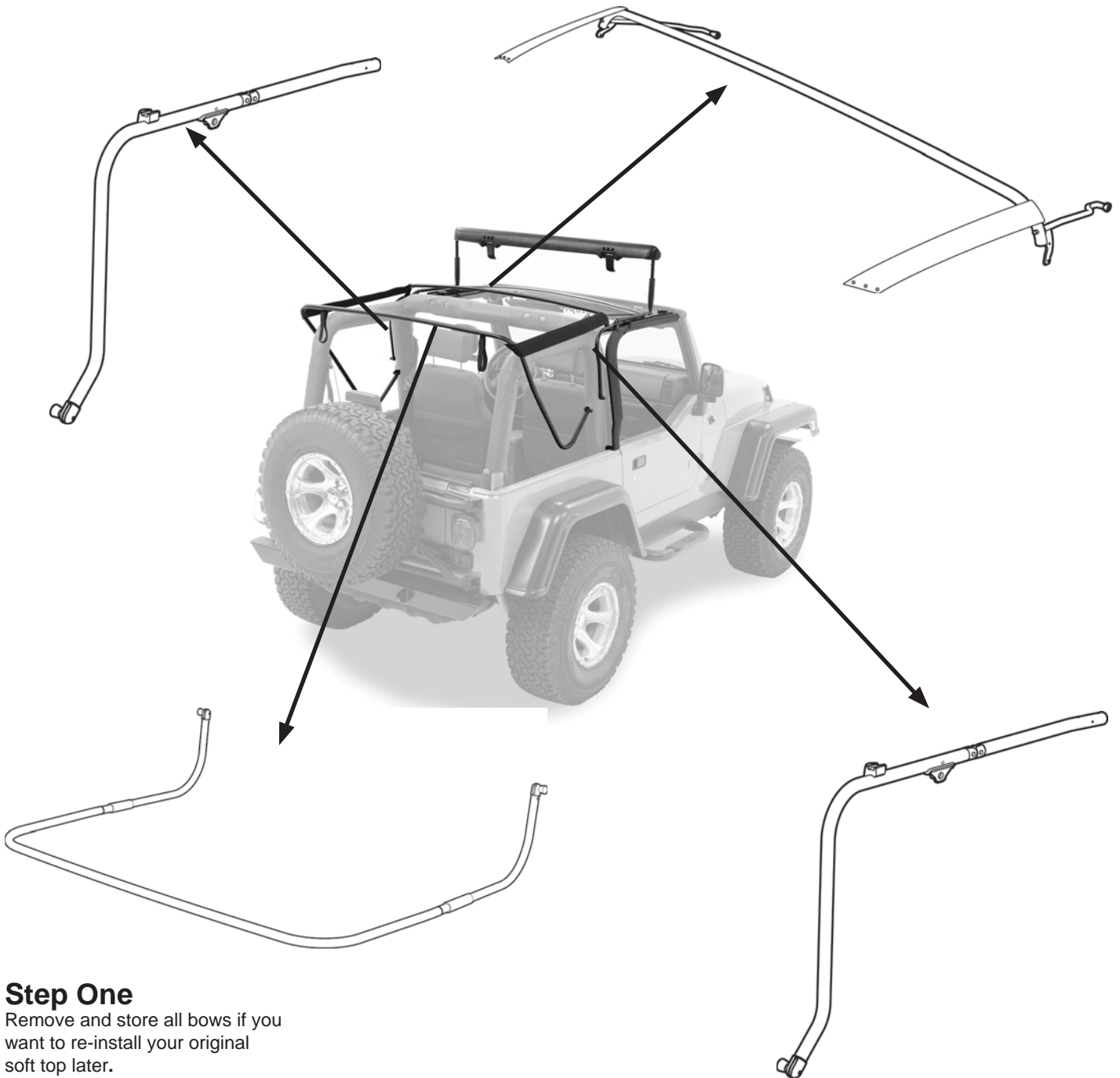

### Step One

Remove and store all bows if you want to re-install your original soft top later.

## Section 4a

### Install Pivot Bracket on ORIGINAL FACTORY Door Surround with Latch Bracket

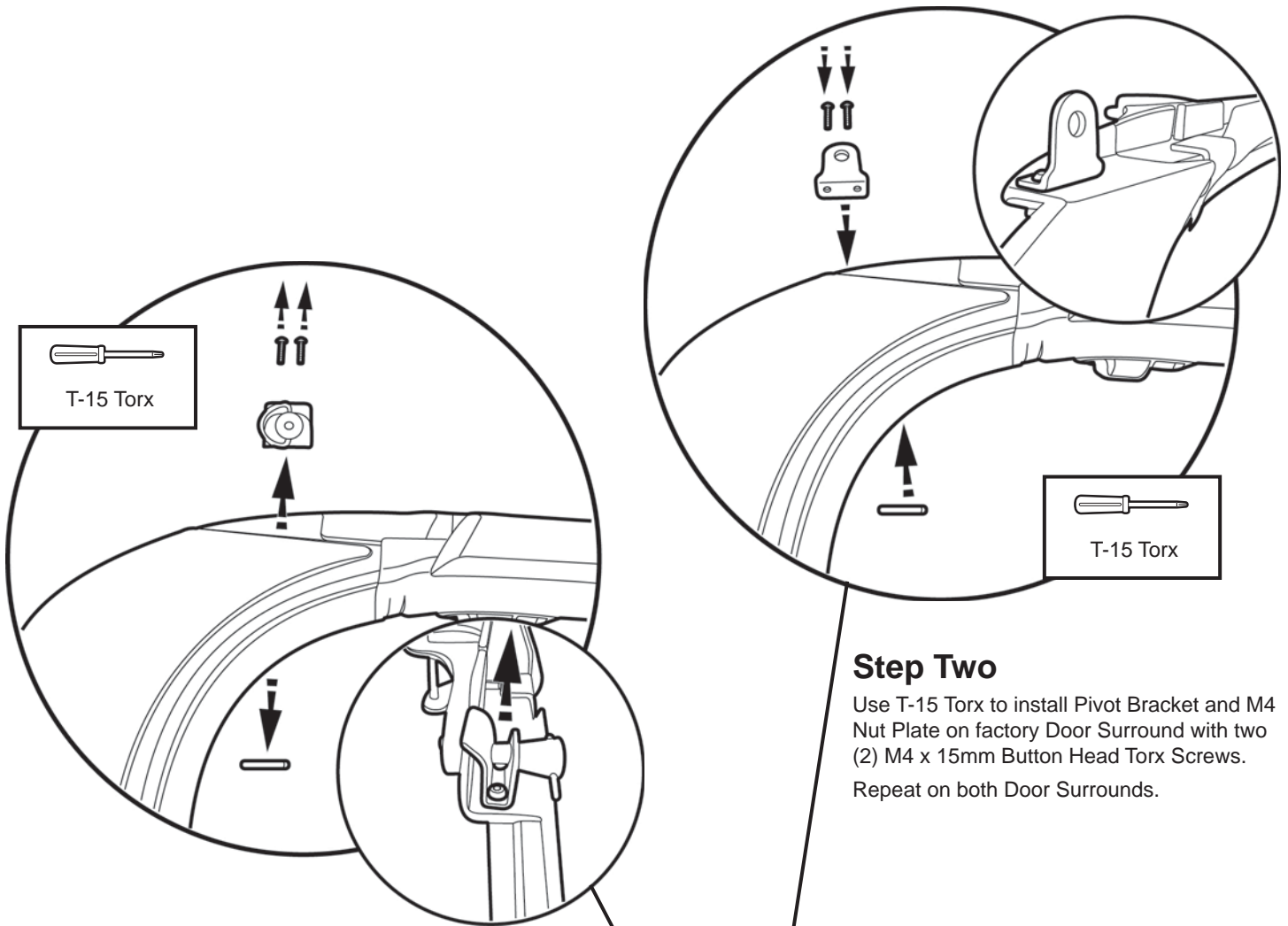

#### Step One

Use T-15 Torx to remove the factory latch bracket from the factory Door Surround.

#### Step Two

Use T-15 Torx to install Pivot Bracket and M4 Nut Plate on factory Door Surround with two (2) M4 x 15mm Button Head Torx Screws. Repeat on both Door Surrounds.





## Section 4b

### Install Pivot Bracket on ORIGINAL FACTORY Door Surround without Latch Bracket

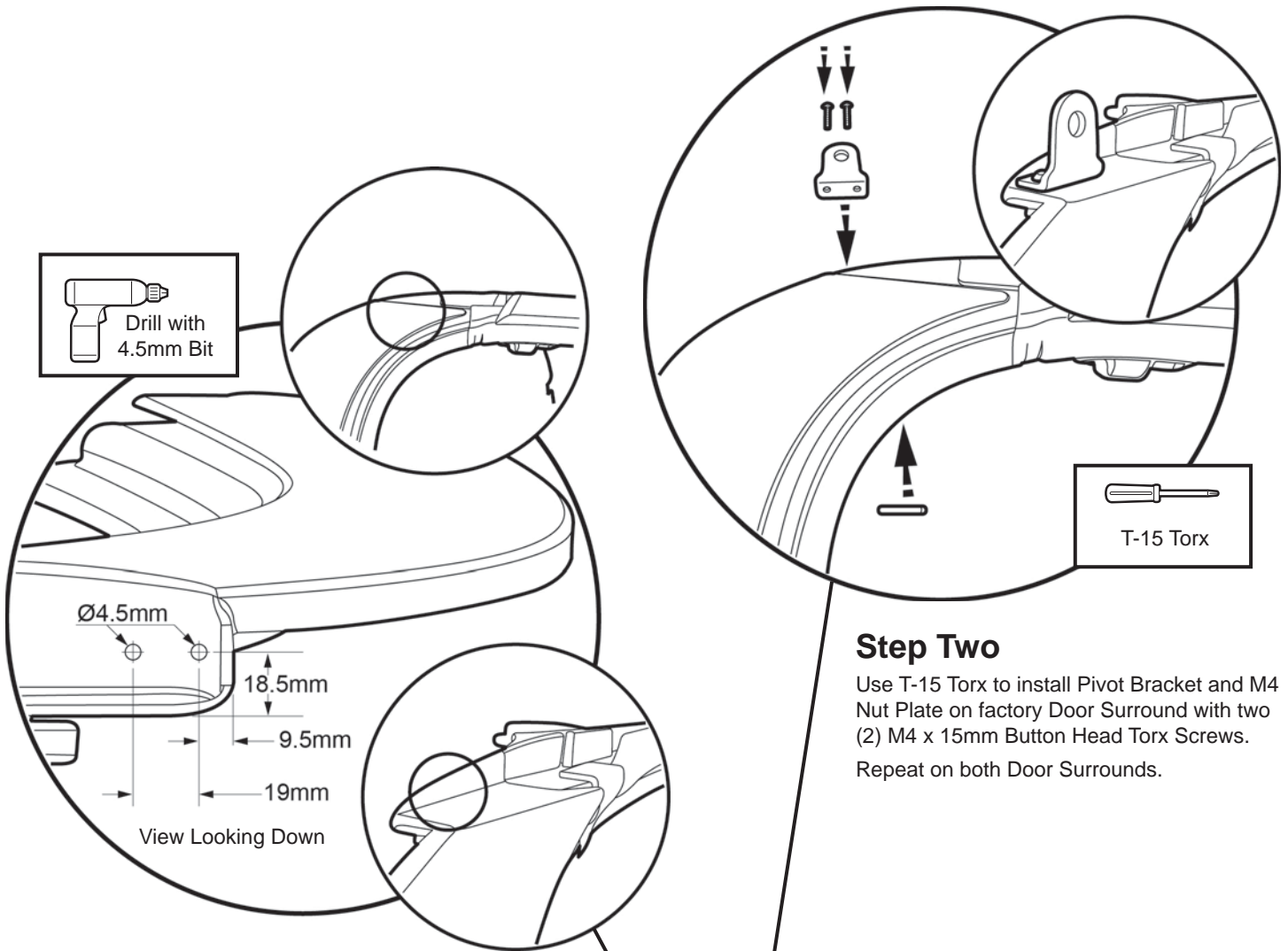

#### Step One

Mark and drill 4.5mm holes as shown.

#### Step Two

Use T-15 Torx to install Pivot Bracket and M4 Nut Plate on factory Door Surround with two (2) M4 x 15mm Button Head Torx Screws. Repeat on both Door Surrounds.



## Section 5a

## Remove Side Bow from ORIGINAL FACTORY Header

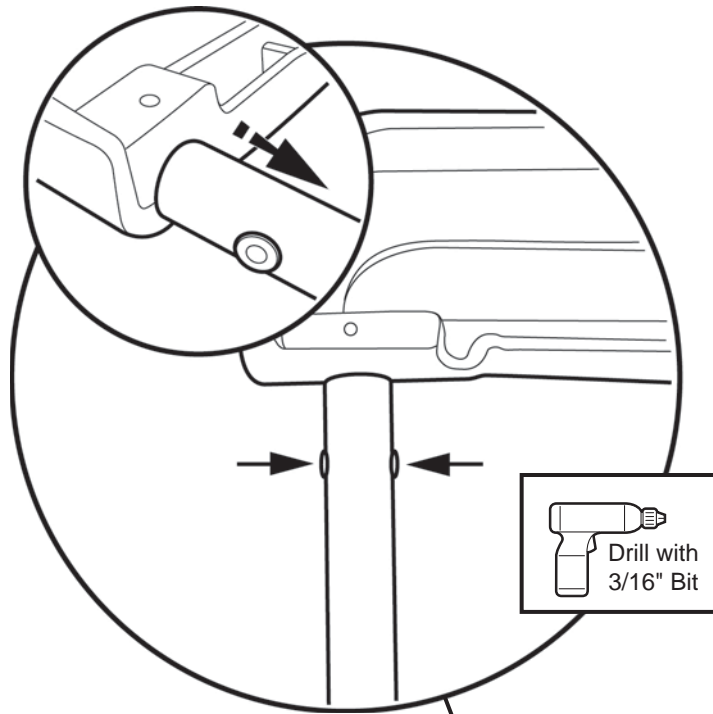

### Step One

Use a 3/16" bit to drill out rivet that secures side bow to header. Remove bow.

Repeat on both sides of header.



## Section 5b Remove Side Bow from AFTERMARKET Header

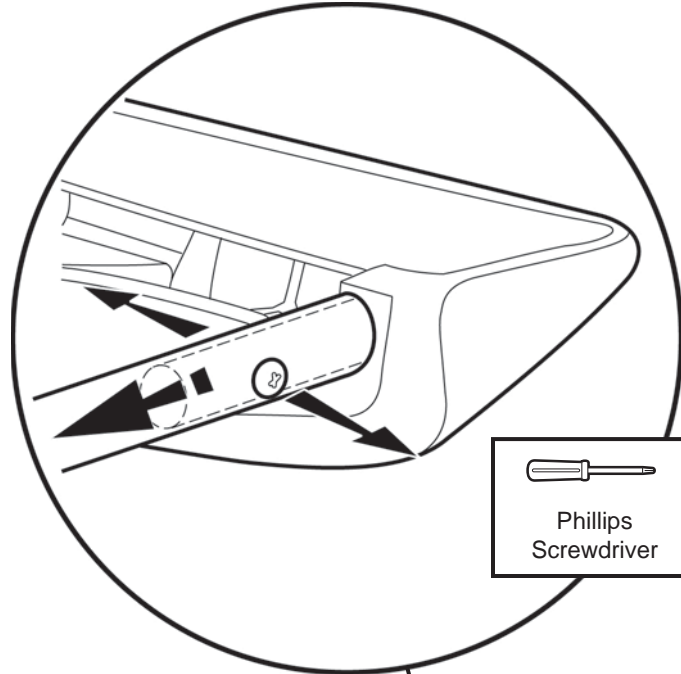

### Step One

Remove screws that secure side bow to header. Remove bow.  
Repeat on both sides of header.



## Section 6 Install Side Bows on Header

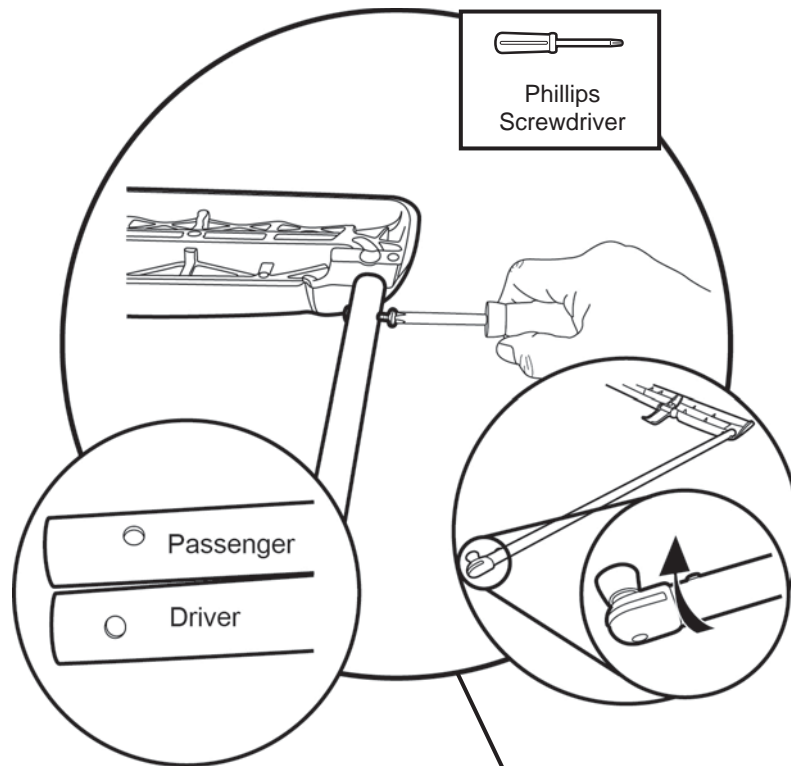

### Step One

Lay the Header upside down. Match the holes in the Side Bows with the holes in the Header. Orient the so the knobs point inward. Slide the Bows over the pins on each side of the Header. Use two (2) #12 x 3/8" Pan Head Zinc Screws to secure each Side Bow to the Header.



## Section 7

## Install Top Fabric on Header

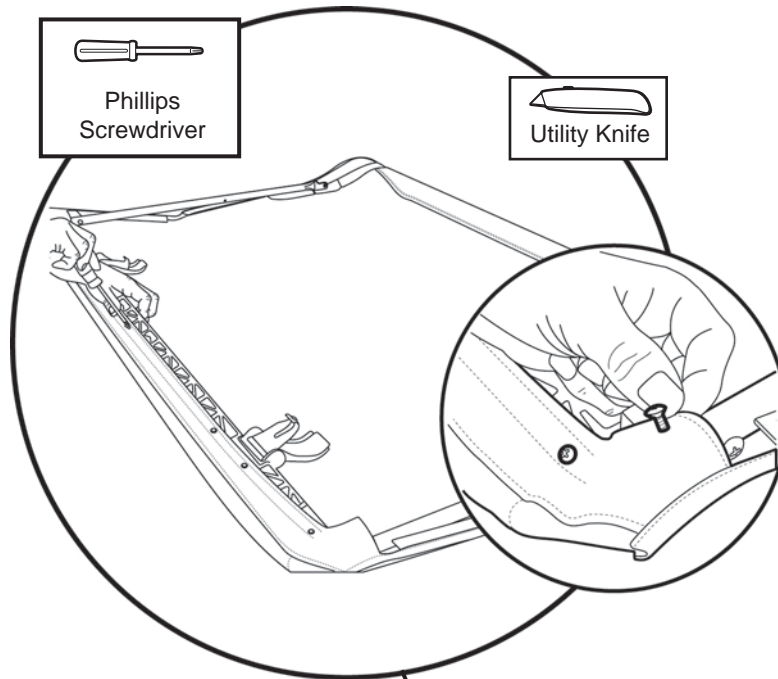

### Step One

Lay the top fabric, backing side up and aligned with the front edge of the Header. Use a utility knife to slit the fabric over each screw position. Locate the round hole that marks the center of the plastic strip (all other holes are slotted). Install a #8 x 5/8" Pan Head Screw in the round hole to secure the fabric to the header as well as to center the top. Then install #8 x 5/8" Pan Head Screws in the remaining holes along the front of the header.

Install an Oval Head Screw in the outside holes on each side of the Header.





## Section 8

## Install Rear Bow

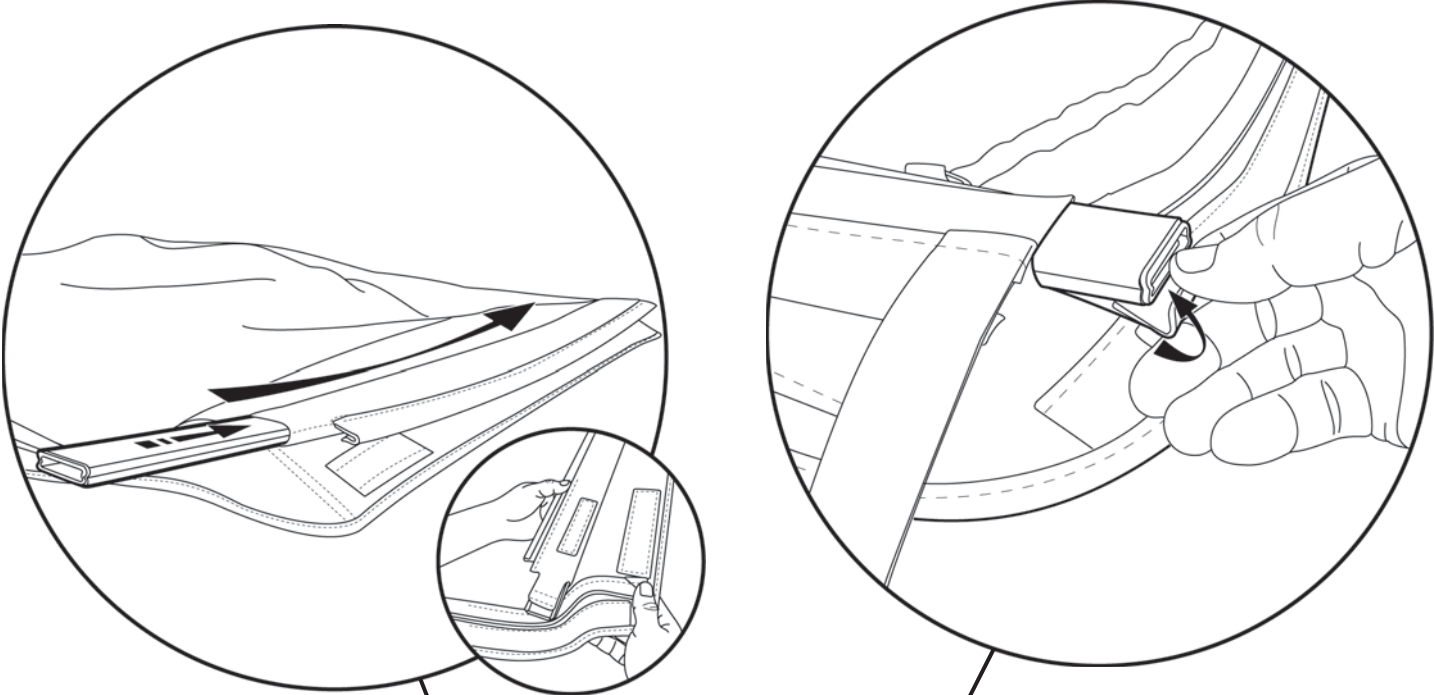

### Step One

Slide the Rear Bow into the pocket inside the rear of the Top Fabric. Secure the J-Hooks on the rear bow flaps to the ends of the Rear Bow.



## Section 9

### Mount Header Assembly to Door Surround

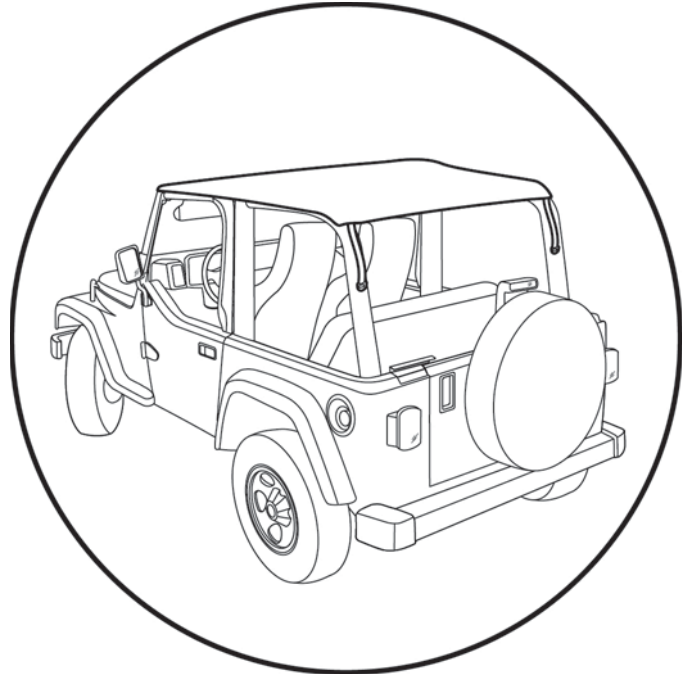
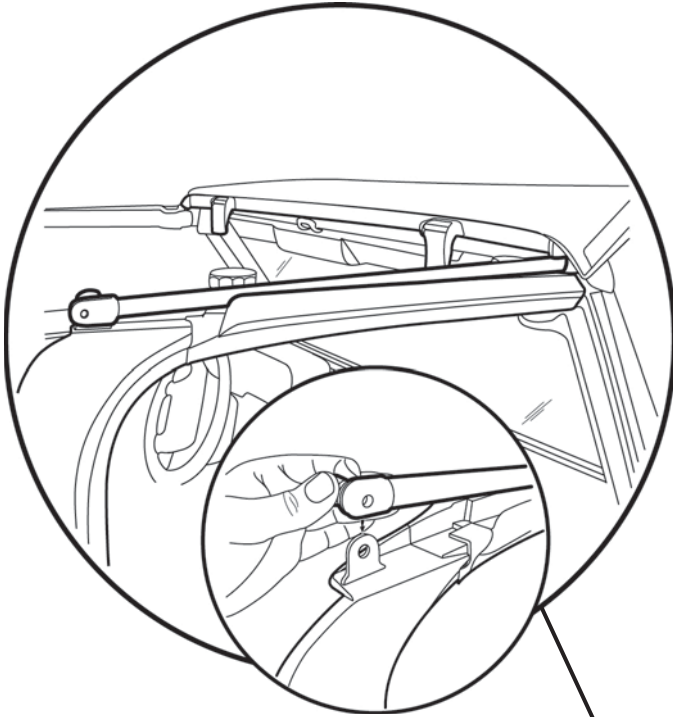

#### Step One

Fold the Top Fabric toward the front of the Header. Place the Header on the vehicle. Pull the release knob on the Side Bow and insert the pin into the Door Surround Bracket. Repeat on the other side of the vehicle.

#### Step Two

Pull the Top Fabric back over the sport bar.



## Section 10 Secure Straps to Sport Bar

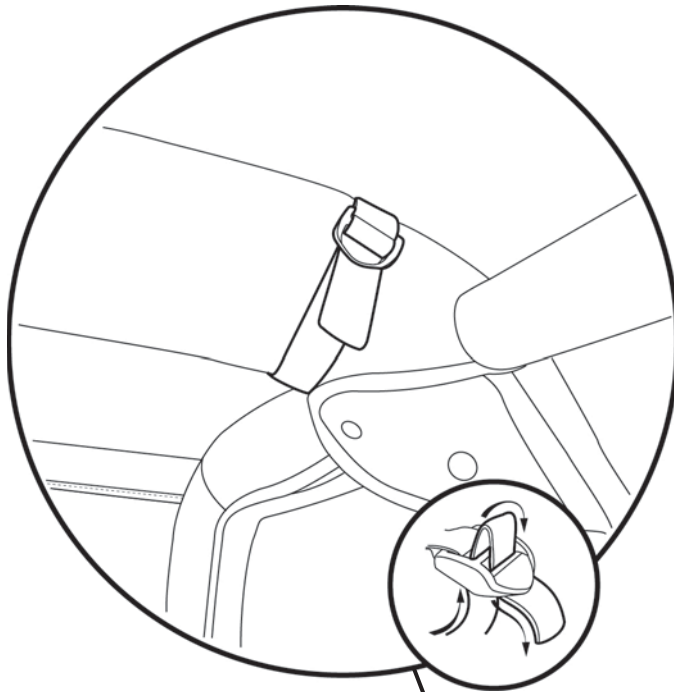

### Step One

Loosen the speaker pod. Slip the straps between the speaker pod and the sport bar. Wrap the straps around the sport bar on each side of the vehicle. Thread the ends of the straps through the buckles and tighten. Tighten the speaker pod.



## Section 11 Secure Rear Strap

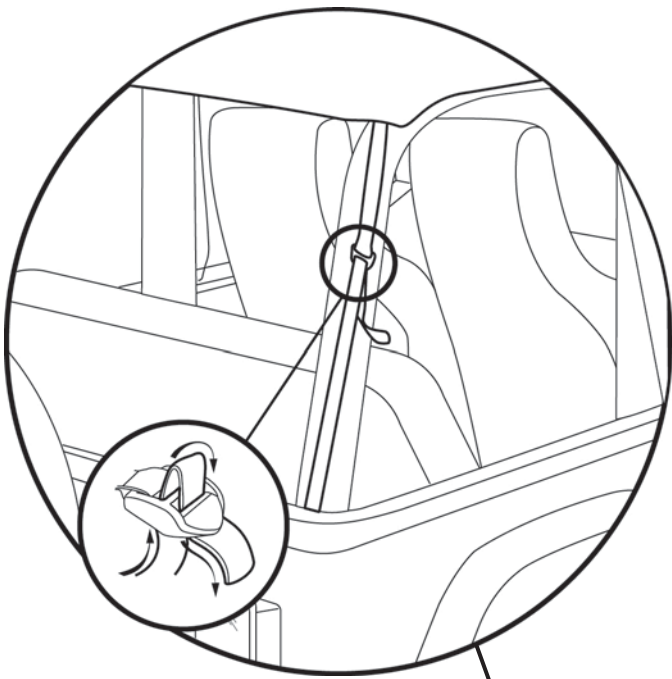

### Step One

Thread a J-Hook Buckle Strap through the buckle on one of the rear straps.

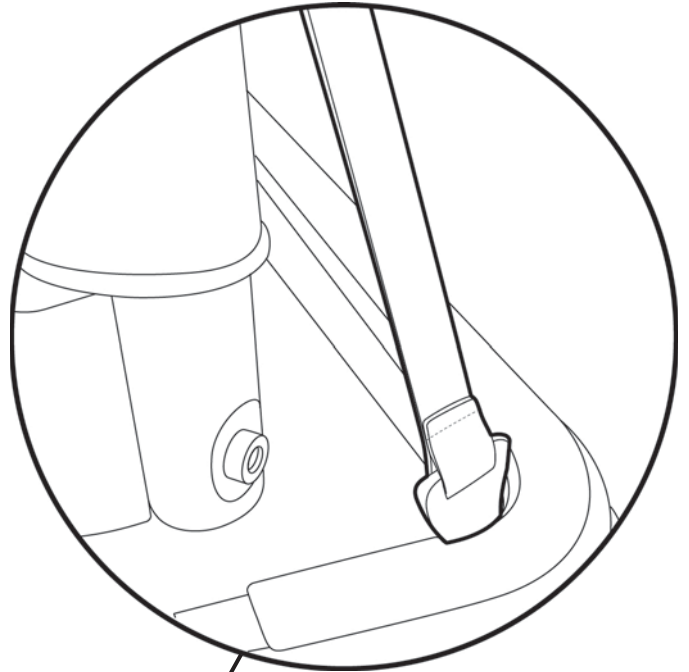

### Step Two

Hook the strap to the ledge inside the rear corner of the vehicle. Repeat on both sides of the vehicle.

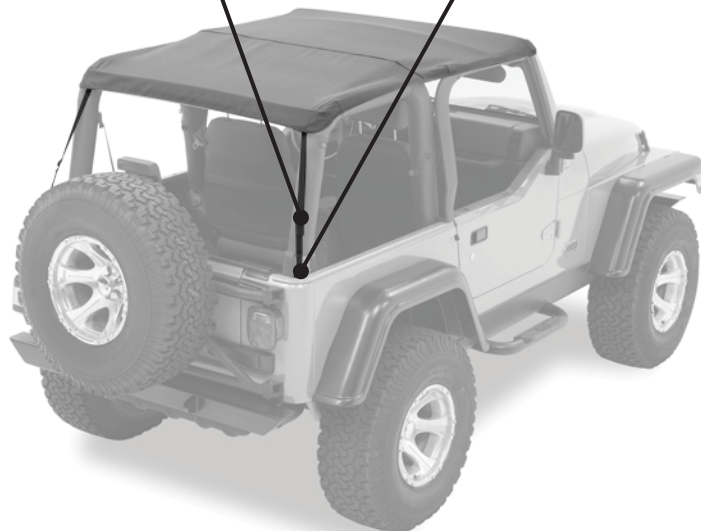

## Section 12 Install Rear Window

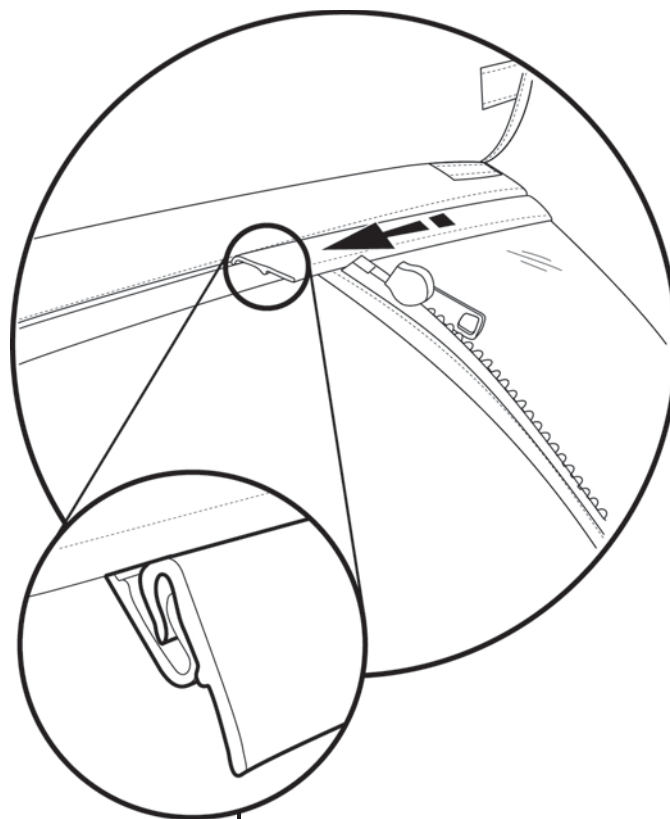

### Step One

Align the J-slide with the J-slide sewn into the rear of the Top. Slide them together until the Rear Window is centered in the opening.





## Section 13 Install Quarter Windows

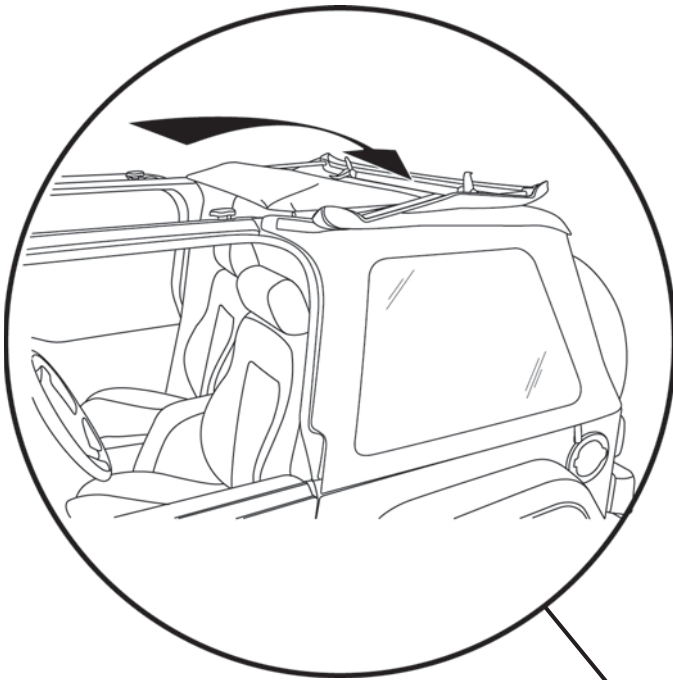

### Step One

Open the header to make it easier to install the Quarter Windows and the Rear Window.

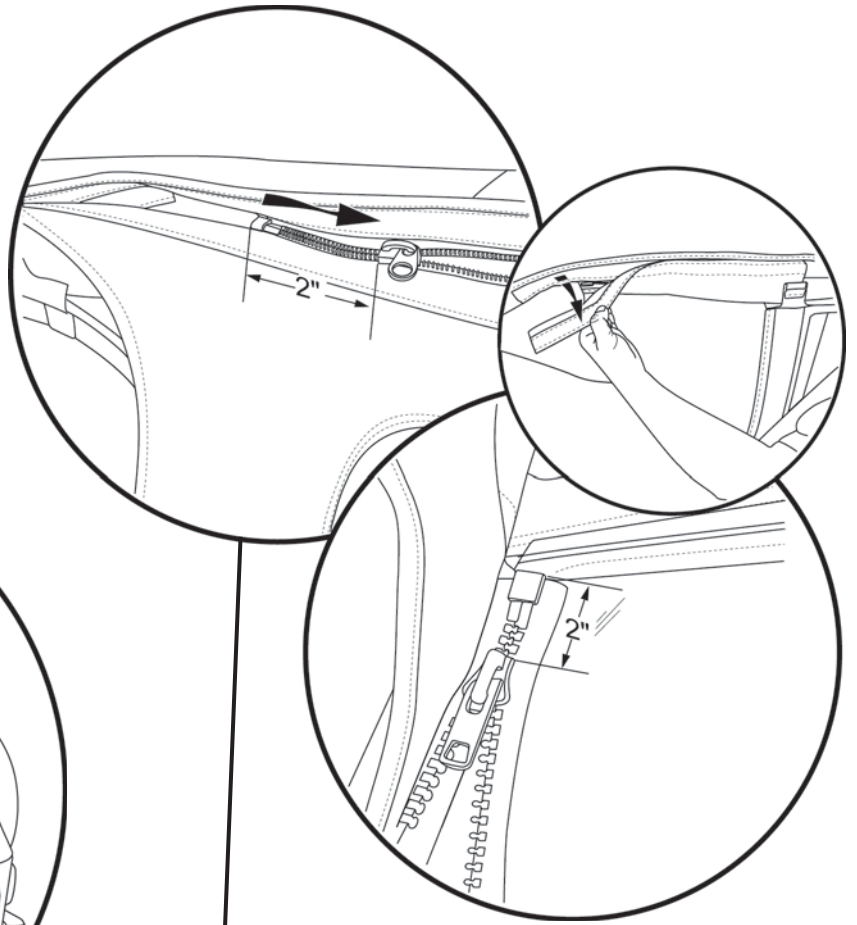

### Step Two

Separate the protective flap covering the hook strip on the side of the Deck. Open the flap toward the inside of the vehicle.

Start the zipper along the top of the Quarter Window with the zipper in the Top. Only close the zipper 1-2". Repeat with the rear zipper and the zipper on the Rear Window. Repeat with both Quarter Windows.



## Section 14

## Secure Quarter Windows to Door Surround

### Step One

Slip the plastic strip on the front of a Quarter Window into the channel in the Door Surround. Repeat with both Quarter Windows.

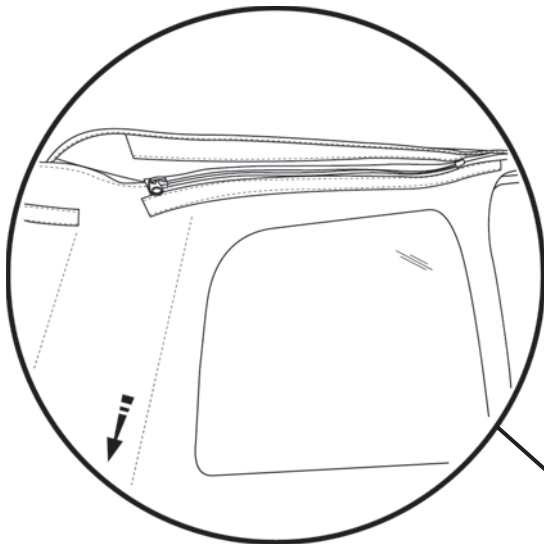
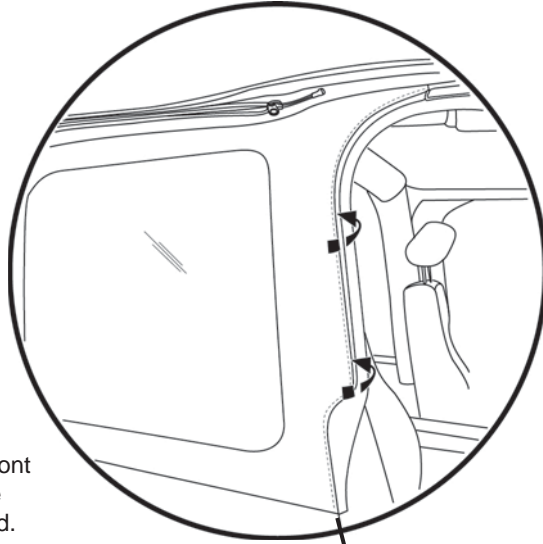

### Step Two

Close the zippers along the top of each Quarter Window.

Push Plastic Reinforcement down to make it easier to close zipper.

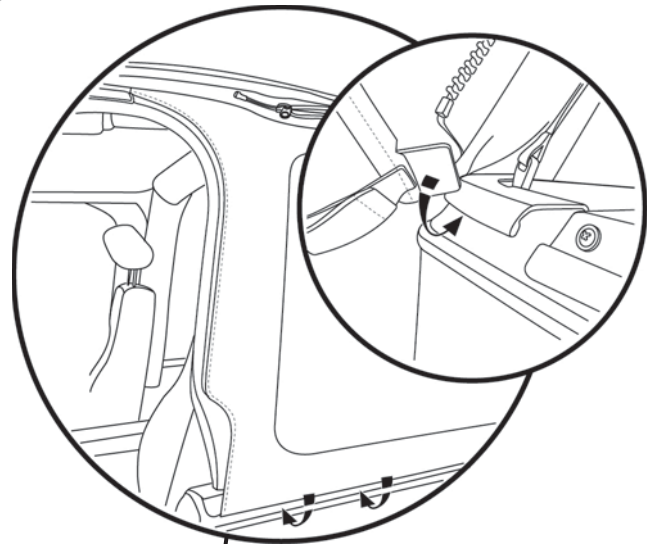

### Step Three

Slip the plastic strip along the bottom of the Quarter Windows into the channel in the belt rail on each side of the vehicle.

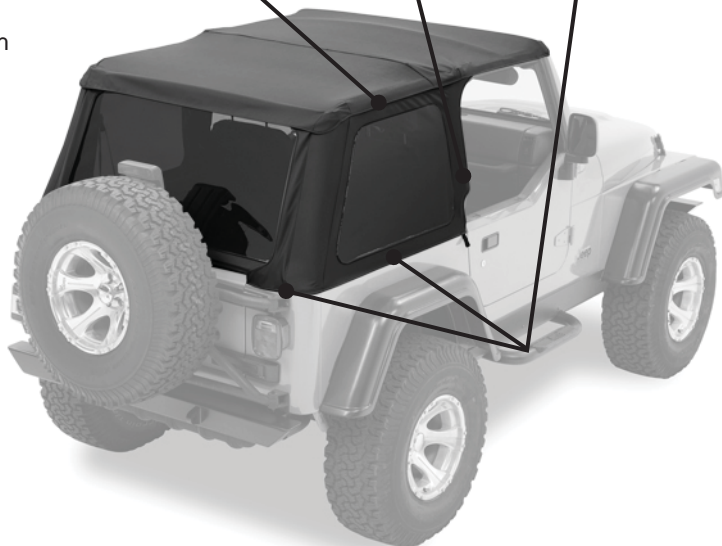

## Section 15 Install Tailgate Bar

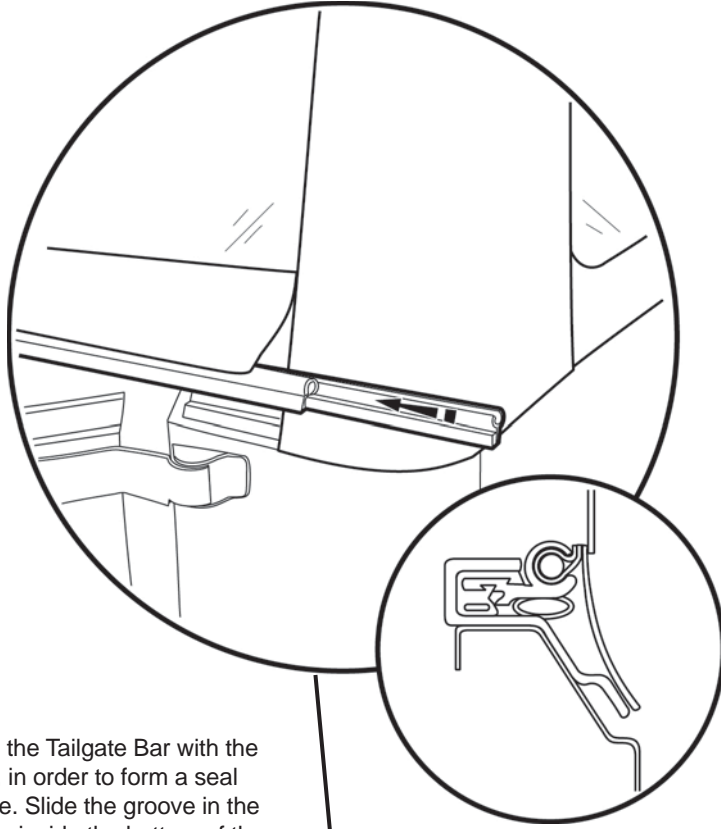

### Step One

Open the tailgate. Orient the Tailgate Bar with the rubber bulb facing down, in order to form a seal with the top of the tailgate. Slide the groove in the Tailgate Bar onto the tube inside the bottom of the Rear Window. Roll the Tailgate Bar into the top of the Tailgate Mounts.

Close the Rear Window zippers.



## Section 16 Secure Rear Window to Tailgate Mounts

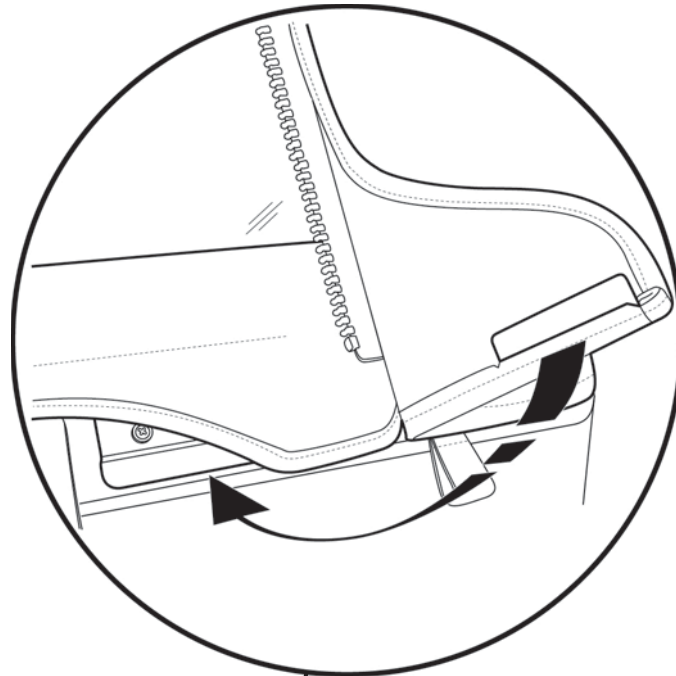

### Step One

Slip the plastic strips along the bottom of the Rear Window into the channel in the Tailgate Mounts on each side of the tailgate.

Wrap the Quarter Windows over the Rear Window and slip the plastic strips on each Quarter Window into the channel in the Tailgate Mounts on each side of the tailgate.



## Section 17 Secure Top Fabric to Quarter Windows

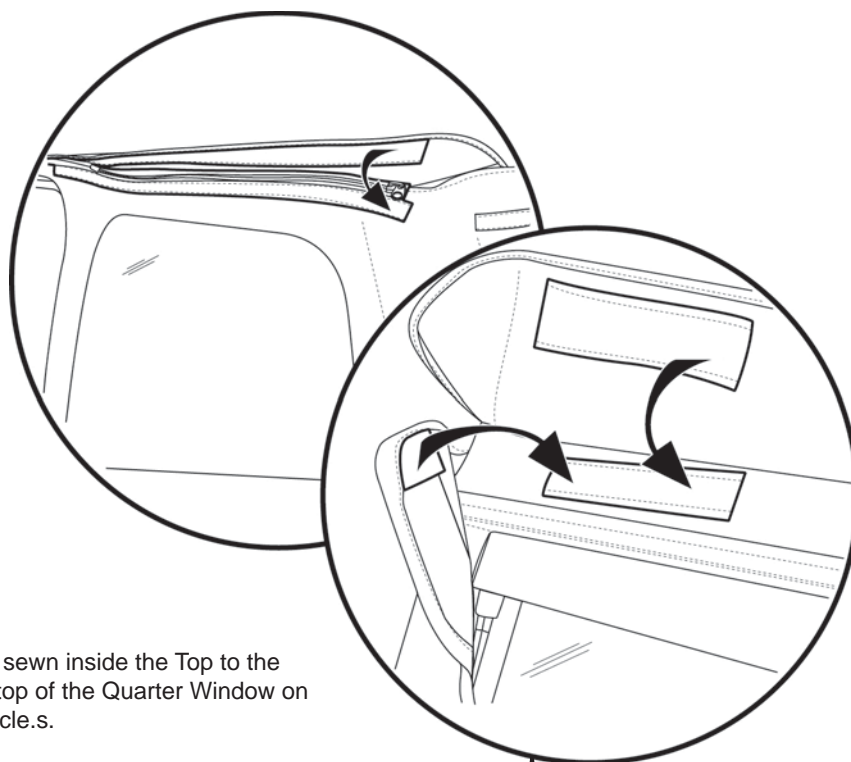

### Step One

Fasten the loop strip sewn inside the Top to the hook strip along the top of the Quarter Window on each side of the vehicle.s.





## Section 18 Secure Header Latches

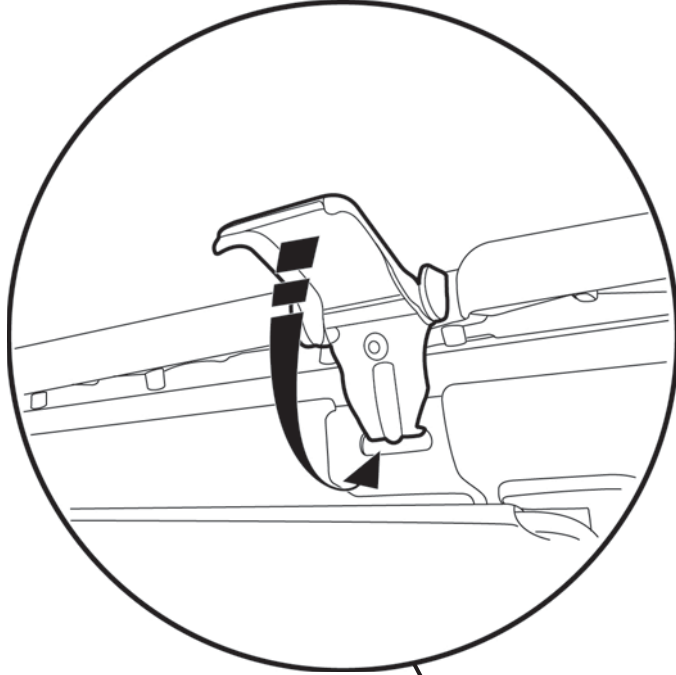

### Step One

Hook the latches on the Header into the holes in the windshield and close them.



## Section 19 Secure Top Fabric to Door Surround

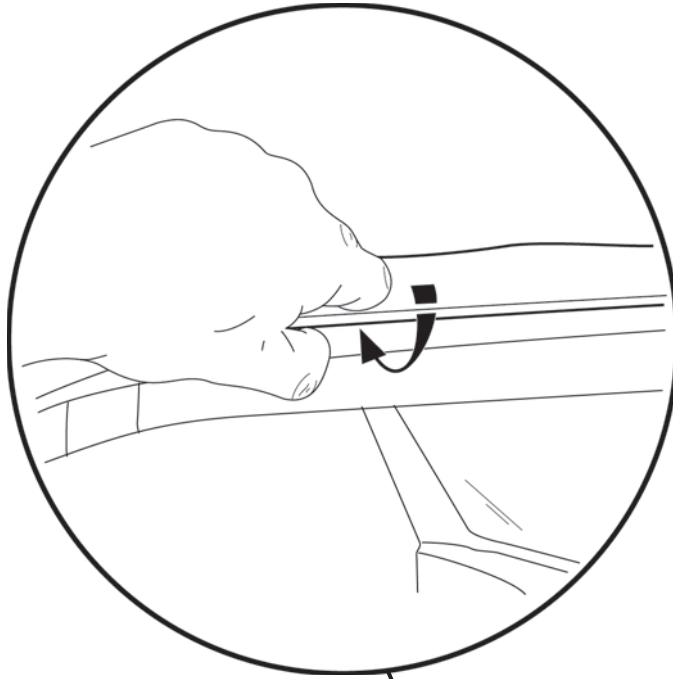

### Step One

Slip the plastic strips above the doors into the channel in the Door Surround on each side of the vehicle..



## Section 20 To Use Sprint Top as a Bikini

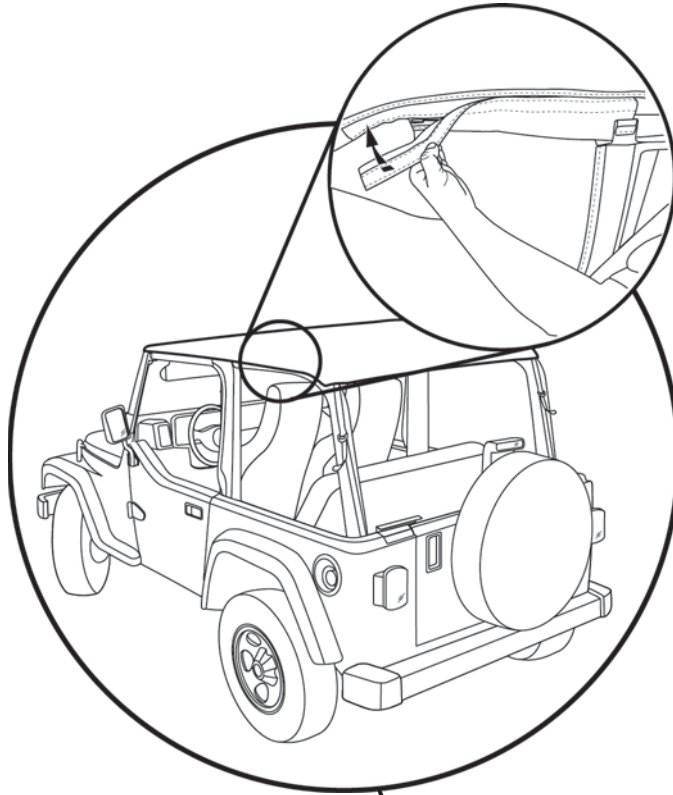

**! WARNING** When operating the vehicle without the Quarter Windows, the Rear Window should be removed for proper ventilation.

### Step One

Your Sprint Top can be used as a Bikini by removing the Quarter Windows and Rear Window and storing them carefully. Fold the protective flaps over to engage the hook and loop tape.



## Care and Maintenance of your Pavement Ends Product

Your Pavement Ends product is made of the finest materials available. To keep it looking new and for the maximum possible wear, it will need periodic cleaning and maintenance.

**Fabric:** The fabric should be washed often using soap, warm water and a soft bristle brush. Rinse with clear water to remove all traces of soap. Pavement Ends recommends using Bestop Cleaner (part no. 11201-00) and Bestop Protectant (part no. 11202-00). Bestop Cleaner and Bestop protectant are specially formulated to provide a total cleaning and protection system. Bestop Cleaner safely removes the toughest stains, will not harm vehicle finishes, is biodegradable and environmentally friendly. Bestop Protectant protects against UV-fading, cracking and hardening, and repels dust, grease, dirt and mildew.

**Windows:** Keep windows clean to avoid scratching. DO NOT use a brush on the windows! Wash with a water-soaked cloth or sponge and a mild dishwashing detergent. Pavement Ends recommends Bestop Vinyl Window Cleaner (part no. 11203-00), which safely cleans and protects vinyl windows and helps prevent UV damage. NEVER WIPE THE WINDOWS WHEN THEY ARE DRY. Be careful when cleaning snow or frost from the vinyl windows since they are easily scratched and may crack at low temperatures. DO NOT roll the sides or rear window in cold weather. The windows become stiff and will crack. Cracks caused by misuse in cold temperatures are not covered under warranty.

**Zippers:** Keeping zippers cleaned and lubricated with Bestop's Zipper Cleaner (part no. 11206-00) will help prevent damage and keep the zippers in smooth working condition. If a zipper opens behind the slider, the slider may have been spread apart. This problem can usually be repaired by using an ordinary pair of pliers to bring the sides back into parallel. Return slider to the end of the zipper in the normal Open position. Squeeze lightly at first and test the zipper. If the zipper continues to remain open squeeze more firmly with the pliers and try the zipper again. Repeat this procedure until the zipper operates correctly.

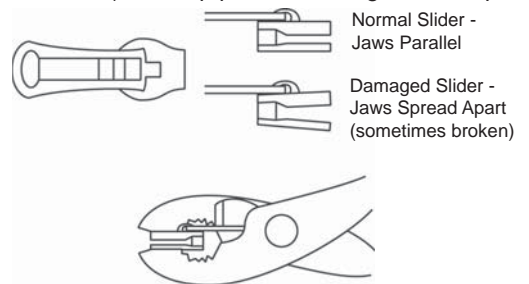

**Water:** Seeping through at the seams may be stopped by applying 3-M Scotchgard® on the inside of the seams. Rips in the fabric may be repaired with Bondex® iron on patches. Iron the patches to the Inside of the top, carefully following the Bondex® instructions.

**Snaps:** Keep snaps cleaned and lubricated with silicone to help prevent snaps from sticking to the studs. If a snap does become stuck to a stud, use a screwdriver and GENTLY pry apart to prevent permanent damage to the snap or the top fabric.

---

### LIMITED WARRANTY

We warrant our product to be free from defects in material and workmanship, for terms specified below, provided there has been normal use and proper maintenance. This warranty applies to the original purchaser only. All remedies under this warranty are limited to the repair or replacement of any item or items found by the factory to be defective within the time period specified.

If you have a warranty claim, first you must call our factory at the number below for instructions. You must retain proof of purchase and submit a copy with any items returned for warranty work. Upon completion of warranty work, if any, we will return the repaired or replaced item or items to you freight prepaid. Damage to our products caused by accidents, fire, vandalism, negligence, misinstallation, misuse, Acts of God, or by defective parts not manufactured by us, is not covered under this warranty.

THE WARRANTY TIME PERIOD IS AS FOLLOWS: ALL "GOODS" MANUFACTURED BY OUR COMPANY: THREE (3) YEAR FROM DATE OF PURCHASE.

ANY IMPLIED WARRANTIES OF MERCHANTABILITY AND/OR FITNESS FOR A PARTICULAR PURPOSE CREATED HEREBY ARE LIMITED IN DURATION TO THE SAME DURATION AND SCOPE AS THE EXPRESS WRITTEN WARRANTY. OUR COMPANY SHALL NOT BE LIABLE FOR ANY INCIDENTAL OR CONSEQUENTIAL DAMAGE.