

INSTALLATION INSTRUCTIONS FOR THE **MICRO SWITCH LIMIT SWITCH** GLL SERIES

50012101

Issue 6



⚠ WARNING

PERSONAL INJURY

- Where possible, install these switches with the conduit opening pointed down to drain moisture away from switch.
- Do not install switch at the low point of a conduit run.
- Install a fitting into the conduit opening that provides strain relief to the wires/cable, as well as sealing against contaminants found in the application.
- In applications where fluids or moisture may be present, seal the fitting threads with a product such as Teflon tape or pipe dope.

Failure to comply with these instructions could result in death or serious injury.

GENERAL INFORMATION

1. Refer to page 2 for specifications.
2. Rotate switch head to desired position (90° increments). Review adjusting instructions below.
3. Mount switch using two M4 or #8 screws (not included). Torque screws to mounting surface 4,9 Nm to 5,9 Nm [43.4 in-lb to 52.2 in-lb].
4. All normally closed (NC) contacts are direct opening .

ADJUSTMENT INSTRUCTIONS

To give flexibility in application, the user can perform the adjustments described below in any order before wiring the unit.

ACTUATOR HEAD POSITIONING

The actuator head may be positioned in any of four directions.

1. Remove the four head retaining screws while holding actuator head in place.
2. To prevent actuator spring loss, remove head slowly to relieve spring tension prior to removal.
3. Rotate actuator head to desired position.
4. Position the large diameter end of the actuator spring over the actuator. Place retaining screws through gasket material and position head over screw holes in desired position.
5. Securely tighten the screws to 0,2 Nm [1.7 in-lb] of torque.

POSITIONING LEVER

The lever on rotary actuated units is adjustable to any of the segmented positions 360° around the shaft; however, the degree of rotation is dependant on head position and direction of roller.

1. Loosen the lever retaining screw with a Phillips head screwdriver.
2. Remove lever.
3. Reposition lever to desired location.
4. Securely tighten screw.

REVERSING THE ROLLER LEVER

The roller arm may be reversed to face the roller to the inside or outside of the arm.

ADJUSTABLE LENGTH LEVERS

1. Loosen the lever's adjustment screw using a Phillips head screwdriver.
2. Adjust to desired length.
3. Securely tighten adjustment screw to 1.0 Nm [8.85 in-lb] of torque.

TOP ROLLER PLUNGER

Switches with top roller plunger must be mounted with plunger in desired position. Actuating device must not exceed over travel distance.

WIRING

1. Remove front cover plate screw.
2. Contact block area by terminal screw is labeled for NO (Normally Open) and NC (Normally Closed) contacts.
3. Connect stranded wire (0,75 mm² - 2,5 mm², 18 AWG-14 AWG) or solid wire (0,75 mm² - 1,5 mm², 18 AWG-16 AWG) to desired connector terminals. Use 90°C [194°F] rated wire when ambient temperature is to exceed 75°C [158°F]:
 - Torque switch terminal screws to 0,8 Nm to 1,0 Nm [7.1 in-lb to 8.9 in-lb]
4. Securely tighten cover screw to 0,5 Nm [4.4 in-lb] of torque.

TABLE 1. SPECIFICATIONS

Circuitry	1 NO 1 NC direct opening snap action, slow action (BBM), slow action (MBB); 2NC slow action
Ampere rating	10 A (Thermal)
Supply voltage	300 Vac and 250 Vdc max.
Housing material	Plastic
Termination type	12,7 mm [0.5 in] conduit; 20 mm [0.79 in] conduit
Housing type	EN 50047
Shock	50 g per PEC 68-2-27c (w/o actuator)
Vibration	10 g per IEC 68-2-6 (w/o actuator)
Sealing	IP66, NEMA 1, 12, 13
Approvals	cULus, CE, UKCA, CCC
Mechanical life	5 million operations
Operating temperature range	-10°C to 80°C [14°F to 176°F]



Figure 1. GLLAB, GLLC**B Dimensions and Bar Charts**

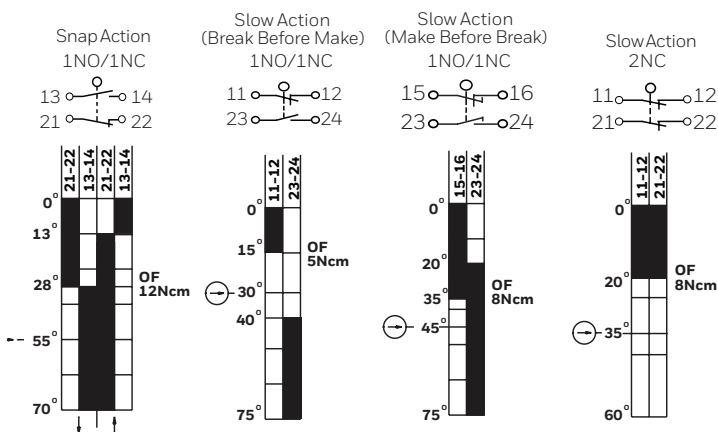
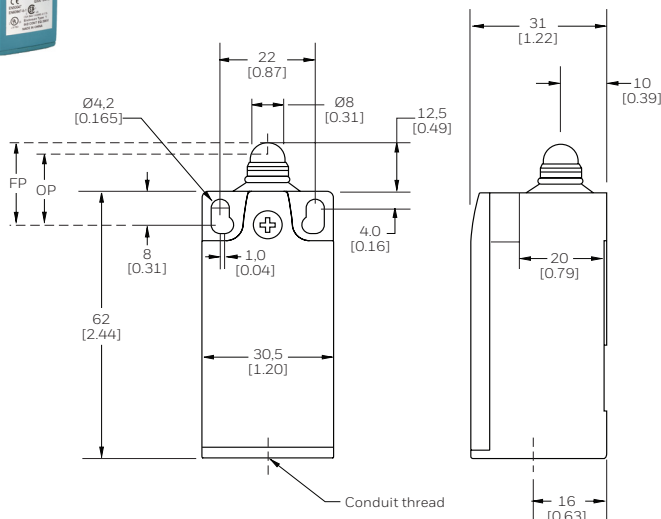

Figure 2. GLLAC, GLLC**C Dimensions and Bar Charts**

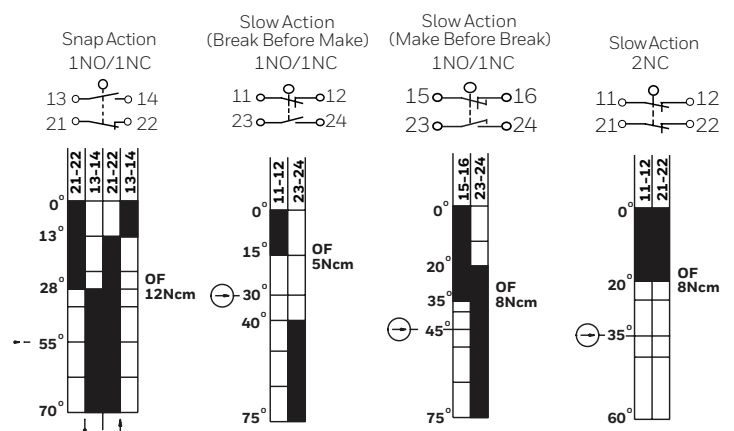
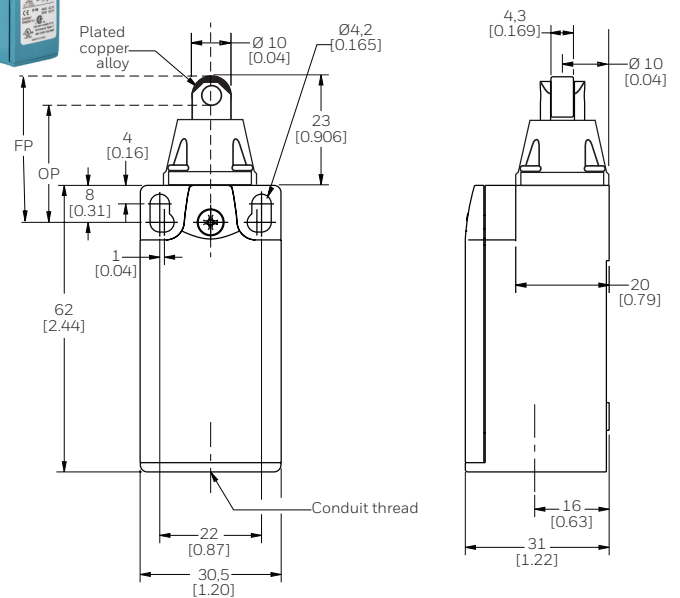



Figure 3. GLLAD, GLLC**D Dimensions and Bar Charts**



Figure 4. GLLAF, GLLC**F Dimensions and Bar Charts**

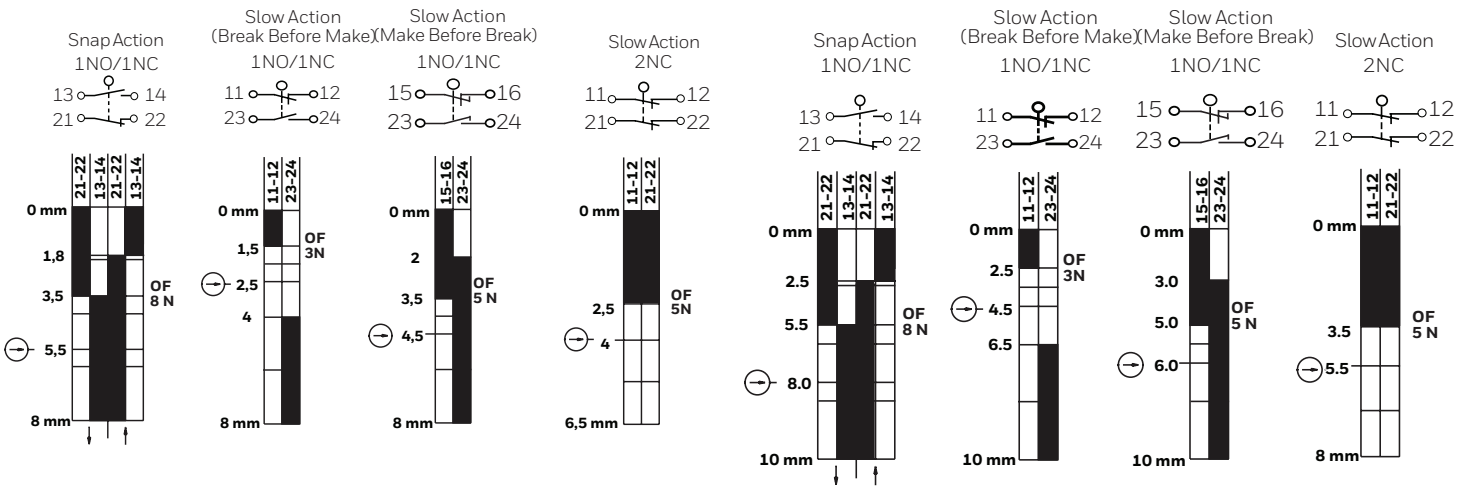
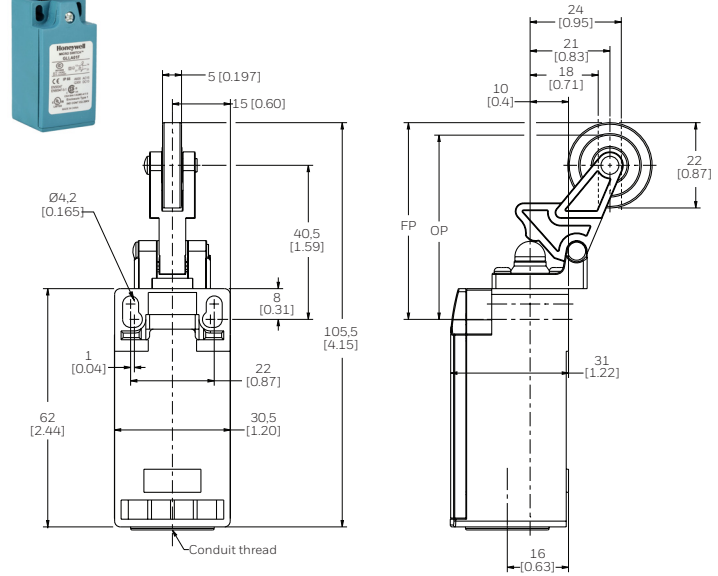
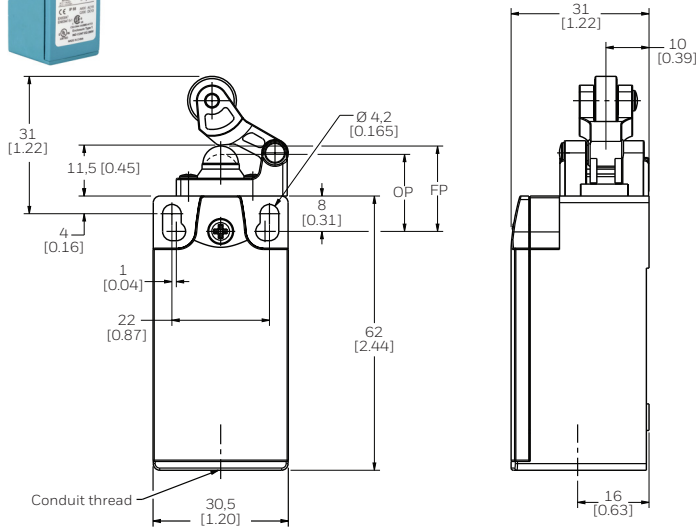



Figure 5. GLLAA1B, GLLC**A1B Dimensions and Bar Charts**

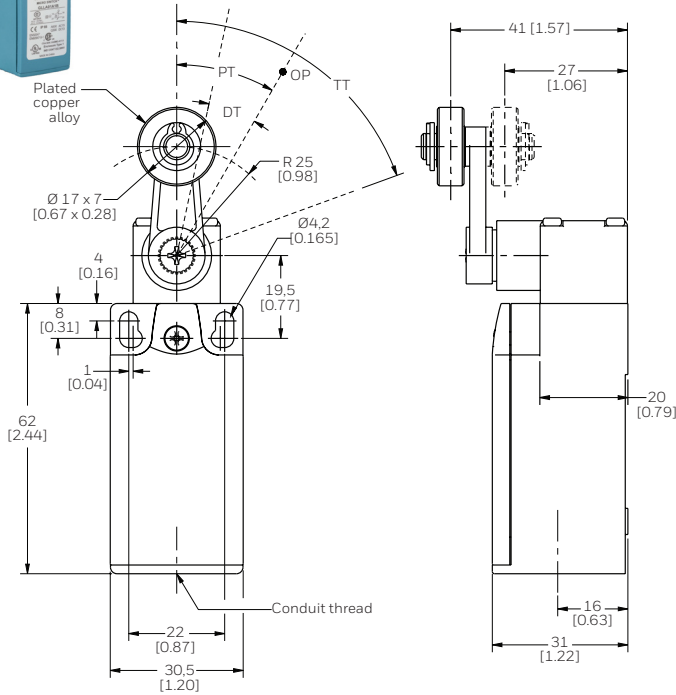

Figure 6. GLLAA2B, GLLC**A2B Dimensions and Bar Charts**

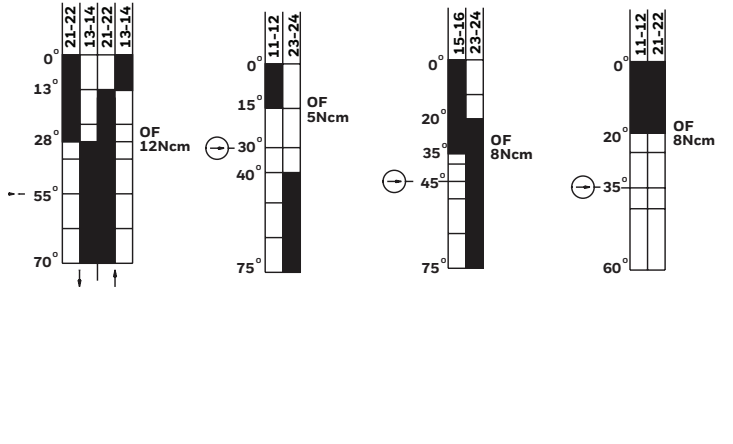
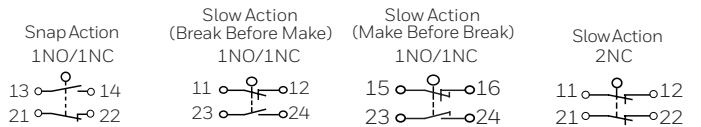
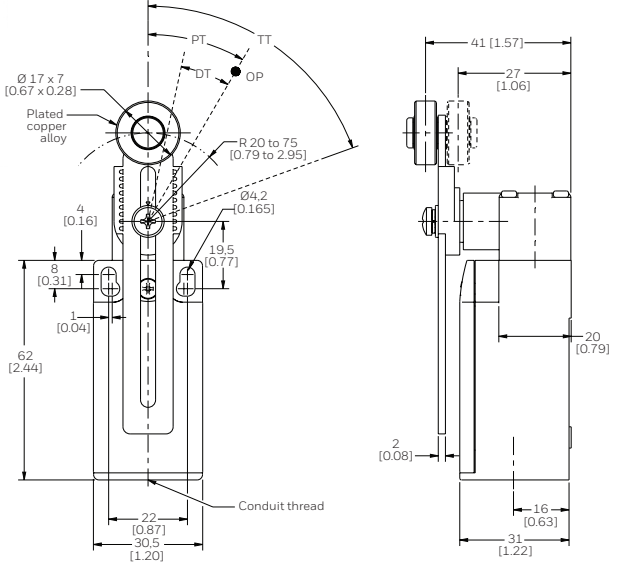
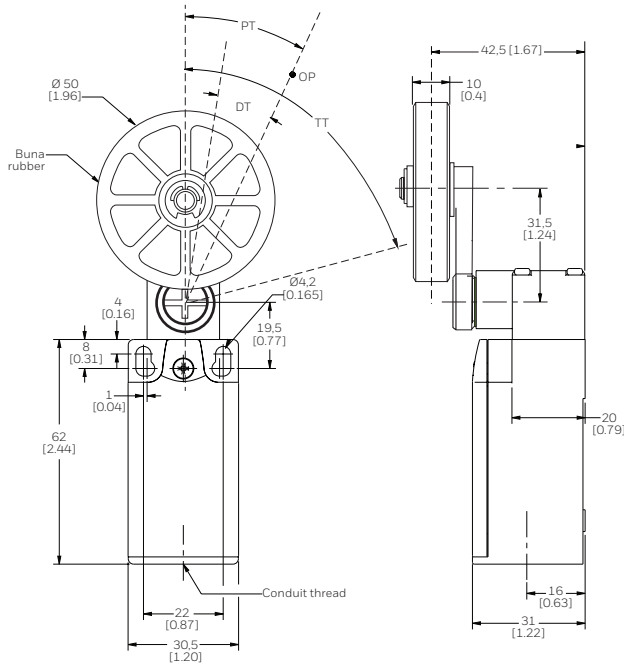
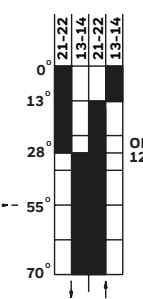
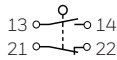



Figure 7. GLLAA1Y, GLLC**A1Y Dimensions and Bar Charts**



Snap Action
1NO/1NC



Slow Action
(Break Before Make)
1NO/1NC

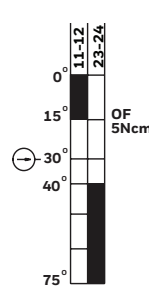
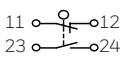

Slow Action
(Make Before Break)
1NO/1NC

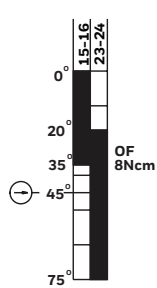
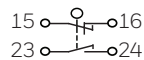

Slow Action
2NC

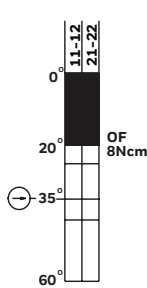
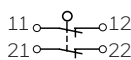
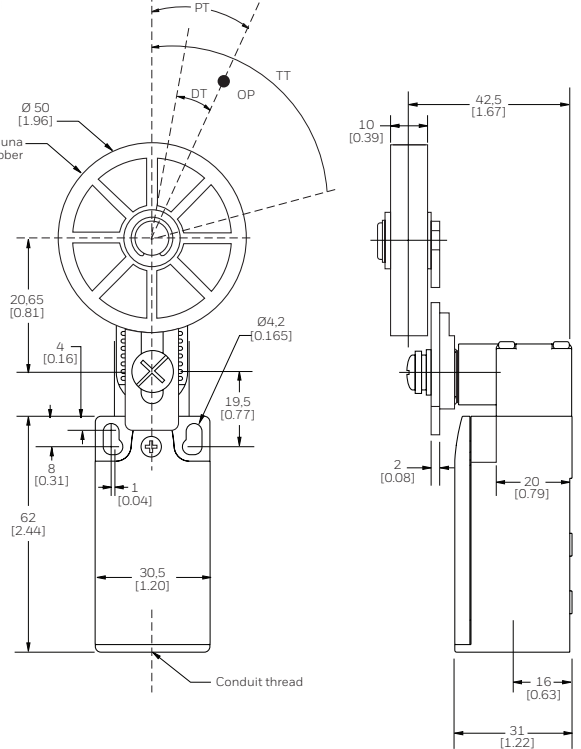
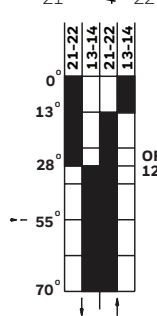
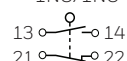

Figure 8. GLLAA2Y, GLLC**A2Y Dimensions and Bar Charts**



Snap Action
1NO/1NC



Slow Action
(Break Before Make)
1NO/1NC

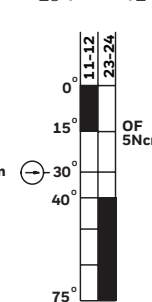
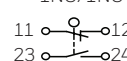

Slow Action
(Make Before Break)
1NO/1NC

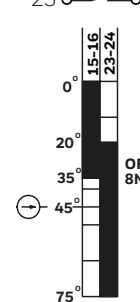
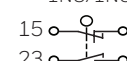

Slow Action
2NC

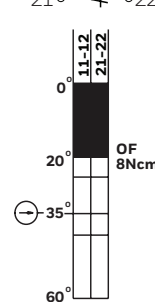
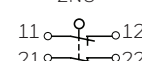
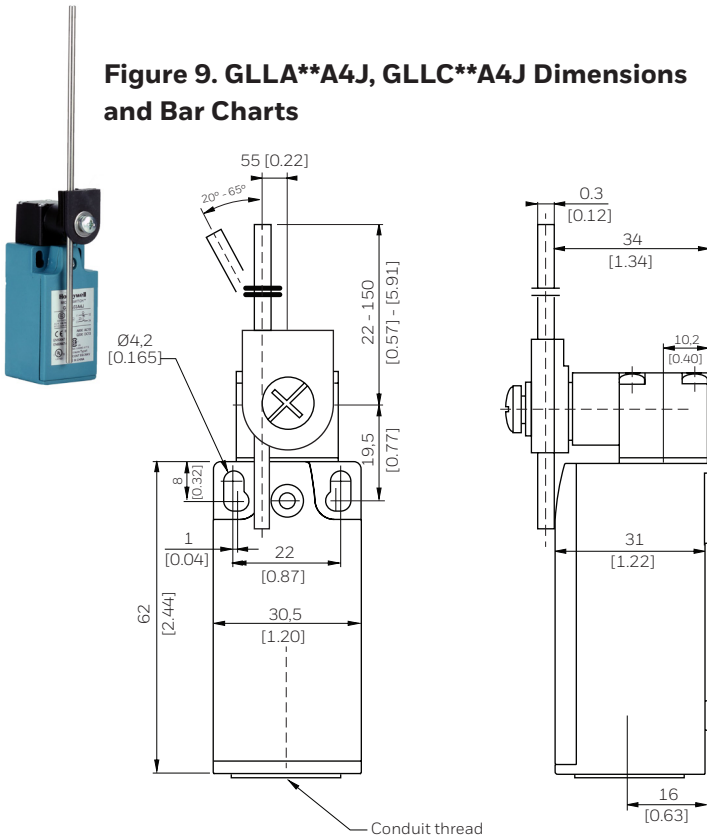
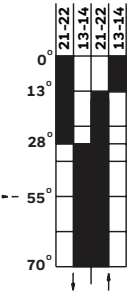
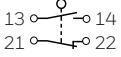

Figure 9. GLLAA4J, GLLC**A4J Dimensions and Bar Charts**



Snap Action
1NO/1NC



Slow Action
(Break Before Make)
1NO/1NC

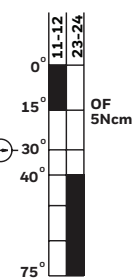
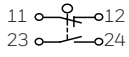

Slow Action
(Make Before Break)
1NO/1NC

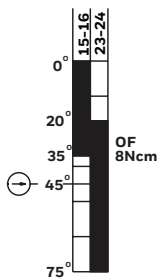
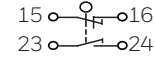

Slow Action
2NC

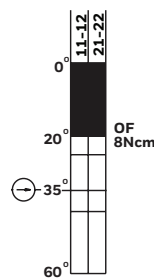
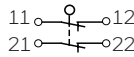

**⚠️ WARNING
IF USED IN APPLICATIONS
CONCERNING HUMAN
SAFETY**

- Only use NC direct opening (“positive opening”/“positive break”) contacts, identified by the symbol 
- Do NOT use flexible/adjustable actuators. Only use actuators designed for safety applications.
- Do NOT defeat, tamper, remove, or bypass this switch.
- Hazardous voltage, disconnect power before servicing.
- Strictly adhere to all installation and maintenance instructions.
- Consult with local safety agencies and their requirements when designing a machine-control link, interface and all control elements that affect safety.

Failure to comply with these instructions could result in death or serious injury.

WARRANTY/REMEDY

Honeywell warrants goods of its manufacture as being free of defective materials and faulty workmanship during the applicable warranty period. Honeywell’s standard product warranty applies unless agreed to otherwise by Honeywell in writing; please refer to your order acknowledgement or consult your local sales office for specific warranty details. If warranted goods are returned to Honeywell during the period of coverage, Honeywell will repair or replace, at its option, without charge those items that Honeywell, in its sole discretion, finds defective. **The foregoing is buyer’s sole remedy and is in lieu of all other warranties, expressed or implied, including those of merchantability and fitness for a particular purpose. In no event shall Honeywell be liable for consequential, special, or indirect damages.**

While Honeywell may provide application assistance personally, through our literature and the Honeywell web site, it is buyer’s sole responsibility to determine the suitability of the product in the application.

Specifications may change without notice. The information we supply is believed to be accurate and reliable as of this writing. However, Honeywell assumes no responsibility for its use.

FOR MORE INFORMATION

Honeywell Sensing and Internet of Things services its customers through a worldwide network of sales offices and distributors. For application assistance, current specifications, pricing, or the nearest Authorized Distributor, visit sps.honeywell.com/ast or call:

USA/Canada	+302 613 4491
Latin America	+1 305 805 8188
Europe	+44 1344 238258
Japan	+81 (0) 3-6730-7152
Singapore	+65 6355 2828
Greater China	+86 4006396841

Honeywell Advanced Sensing Technologies

830 East Arapaho Road
Richardson, TX 75081
sps.honeywell.com/ast