



Installation Instructions Harley-Davidson Saddlebag Lids

Thank you for your purchase of Bagger Audio™ Saddlebag Lids for your Harley-Davidson motorcycle. We have carefully engineered these products to work with Harley-Davidson motorcycles to give you the best quality possible. Cycle Sounds® strives to bring you the highest quality audio products for your motorcycle. Don't forget to check our website www.cyclesounds.com for the most up-to-date product availability.

Taking your valuable investment into consideration, we have detailed the installation instructions for our products. We would like to suggest that you refer to your Harley-Davidson factory service manual for removal of any factory parts. Should you not have this information available, we strongly recommend that your local dealership or professional installation facility assist with your installation.

NOTE: YOU MUST APPLY SOME TYPE OF FINISH TO BAGGER AUDIO SADDLEBAG LIDS AND GRILLS TO PROTECT FROM MOISTURE AND UV RAYS WHICH CAN CAUSE FADING, DISCOLORATION OR RUSTING OVER TIME. THIS STEP IS ESSENTIAL TO ENSURE THE LONGEVITY OF YOUR BAGGER AUDIO PRODUCTS.

BEFORE YOU BEGIN, PLEASE READ INSTRUCTIONS THOROUGHLY AND MAKE NOTE OF THE FOLLOWING GUIDELINES:

Take proper precautions to protect your paint in the areas that you will be working near.

Prior to removal of any parts, confirm that you have all tools necessary to complete the installation.

If you get to a point where you are unsure of how to continue, please review the instructions again and confirm the steps that you have already completed.

If additional assistance is needed please contact Cycle Sounds at 1-866-427-2346 (toll free) or 816-525-2628.

PARTS LIST: *(check for all parts before beginning installation)*

ALL KITS

- (2) BAGGER AUDIO™ Saddlebag Lids
- (2) Rubber Saddlebag Lid Seals
- (2) Metal Speaker Grills
- (2) Hydrophobic Speaker Fabric
- (2) Speaker Grill Fabric Paper Patterns
- (2) Embroidered Fabric Hinge Straps
- (2) Metal Hinge Strap Brackets

COMPLETE KITS ONLY

- (2) 6x9 Marine Grade Speakers
- (1) Mini Amplifier
- (1) SNI-35 – Line Level Converter
- (1) Power Harness
- (2) Speaker Wire Harness (1 short & 1 long)
- (1) RCA to Headphone Jack Converter
- (4) Black Plastic Connectors (quick disconnect)
- (6) Red T-Taps
- (6) Blue Male T-Tap Inserts
- (6) 6" Wire Ties
- (2) 8" Wire Ties
- (8) Adhesive Wire Tie Mounts
- (4) Speaker Connectors (2 sizes)
- (8) Stainless Steel Screws
- (8) Stainless Steel Lock Nuts
- (16) Stainless Steel Washers
- (2) Rubber Grommets

**LIDS ONLY KITS WILL NEED TO GET THESE PARTS TO MOUNT SPEAKERS
(NOT INCLUDED IN LIDS ONLY KITS)**

- (2) BOLTS 10 - 32 X 1/14"
- (6) BOLTS 10 – 32 X 1"
- (8) NYLON LOCKING NUTS 10 X 32
- (16) #10 WASHERS

**FAILURE TO USE THE RECOMMENDED HARWARE FOR MOUNTING SPEAKERS
MAY RESULT IN DAMAGE TO YOUR MOTORCYCLE.**

REMOVE OEM SADDLEBAGS & HARDWARE

1) Remove Saddlebags

Remove the saddlebags from the bike by removing the 2 twist locks that hold them on from the inside of the bag. Find a place where you have the room to work on them one at a time and make sure to lay something down so that you do not scratch the bags.

2) Remove OEM Saddlebag Lids

Detach the factory lid by removing the 2 screws holding the factory strap to inner lid and the 2 screws holding the strap to the inside on the lid. Remove the metal brace from the strap and retain for later use. Next, remove the 5 small torque screws holding lid to factory latch assembly. **(Consult factory service manual for further instructions)**

3) Remove Saddlebag Lid Hardware

Remove the metal strap from behind factory lid seal (This is the metal strap that the previous 5 small torque screws were removed from) and set your factory lids aside. You will no longer need your old lid at this point so you can put them aside where they will be out of the way and won't get damaged.

4) Transfer Secure Tabs to New Saddlebag Lids

Remove the metal secure tabs from OEM lids. Use a heat gun to warm the glue holding the tab and gently pry it away from the lid. Move to the new lid and gently press back into the same place (or purchase these new from your local Harley dealer).

After saddlebags are reassembled and installed back on the bike you may need to make adjustments to the latch assembly secure tabs to ensure the lid will close properly. Tabs must be bent away from the bag; this process may have to be repeated several times for proper closure.

PREPARE BAGGER AUDIO LIDS

1) Cut Speaker Grill Fabric to Provided Pattern

Cut out the **speaker grill fabric paper patterns** (right/left) using a pair of scissors or razor knife. Then lay the pattern onto the speaker grill fabric and trace around it using a suitable marker (white china marker). Once the pattern is transferred to the speaker grill fabric cut the fabric to size.

2) Glue Speaker Fabric to Lids

Using a suitable plastic adhesive, glue the speaker grill fabric to the top of the lid in the speaker grill opening area. Plastic adhesives are available at any auto parts store (car emblem adhesive works well). Press the speaker grill fabric firmly into the glue making sure to stretch the fabric so there are no ripples. Once the glue is dry and fabric is secure, punch out the 4 speaker mounting holes using a sharp knife or tool.

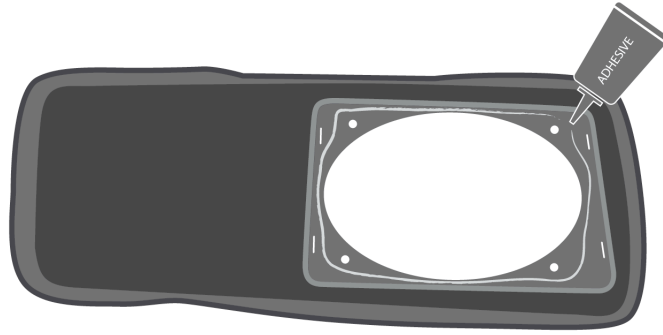

Glue Speaker Fabric to Lids

3) Install Lid Seals on Bagger Audio Saddlebag Lids

Wipe down the inner lip of the Bagger Audio Lid with rubbing alcohol and let dry before applying the rubber seal to the lid. Start by adhering the seal behind where the strap will be located, working your way all the way around the lid.

4) Mount Speakers in Bagger Audio Lids (Hardware Provided with Complete Kits Only!)

Lay out the mounting hardware that came with your kit to ensure there are no missing pieces. There should be **8 screws** and **8 nuts** with **16 washers**. 2 of the bolts will be longer than all the rest and they go through where the strap will be bolted (**see illustration**). Put a bead of silicone around the speaker mounting holes to help prevent water from getting through. Put one washer on all the bolts and insert bolts through the four holes from the top side of the lid. Next, put the screws through the mounting holes on the speaker and add another washer to each bolt before securing the speaker using the supplied lock nuts.

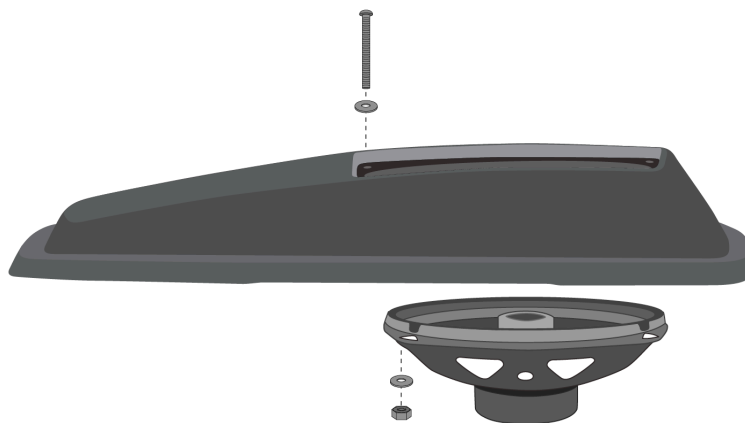

Mount Speakers in Lids

Mounting the speaker works best by inserting bolts through the top of the lid and then setting the lid on its side to attach the speaker. When securing the speaker make sure

the connection terminals on the speaker are pointed towards the front of the bag. Once all screws, bolts and washers are attached tighten the nuts until there is no movement of the speaker. **DO NOT over tighten these bolts.**

Tip: Before installing the speaker grill use a Sharpie to darken the chrome bolt head and washer so it is not noticeable through the speaker grill.

5) Attach the Speaker Grills to Lids

Note: You may need to cut some of the fabric away from the speaker grill slots on the lid to get the grill to go in.

Insert the tabs on the speaker grill into the mounting slits from the top of the bezel. Then, from underneath the bezel bend the tabs on the speaker grill to a 90 degree angle while holding the grill in place to keep it tight. Once you have the grill in place with tabs bent put silicone over the tab slots on the bezel from the bottom side to help prevent water from getting into your bag. **(See Illustrations)**

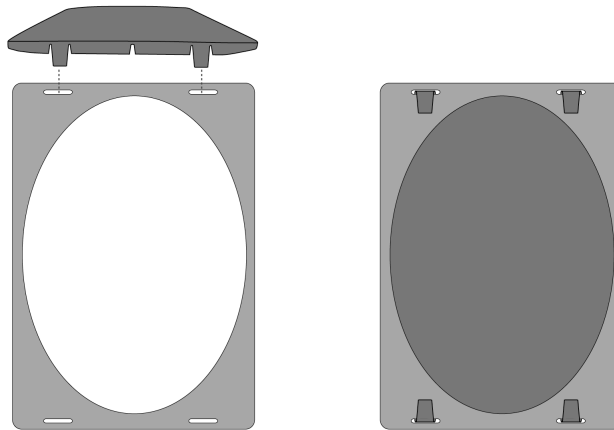

Attach the Speaker Grill & Bend Tabs

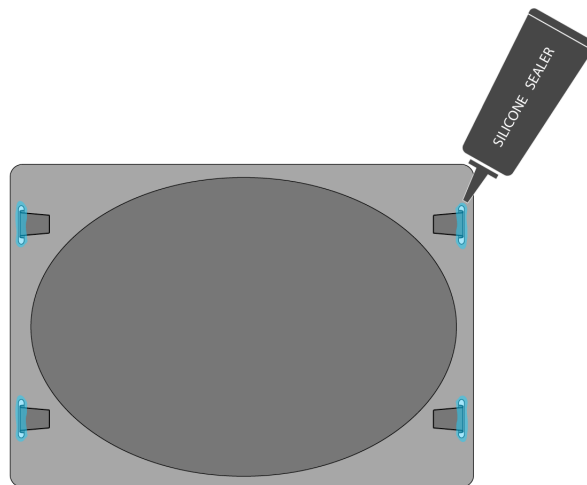

Silicone the Speaker Grill Tab Openings

6) Attach OEM Hardware to New Saddlebag Lid

Attach Bagger Audio lid by installing the 5 small torque screws in the same location as on the factory lid. (We suggest that you have an assistant hold the lid in place while attaching the new lids) Don't forget to attach the metal bracket onto the lid that came from the OEM lid.

7) Install Hinge Straps with Metal Braces

Take one of the metal braces that came in the kit along with a hinge strap and attach it to the closest speaker mounting hole using one of the longer mounting screws provided in the kit. Then, screw the other side of the strap and brace to the mounting hole that is in the lid. Take the original metal bracket from the strap and inset it into the new strap and attach to the bag as on the factory strap.

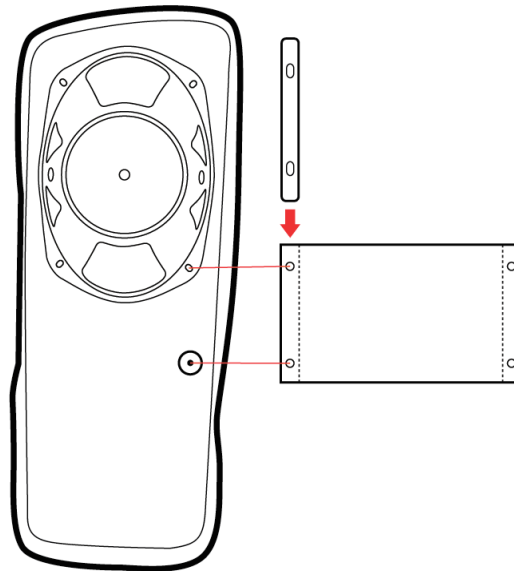

Attach Bagger Audio Hinge Straps to Bag and Lid

**REPEAT THIS PROCESS FOR THE SECOND SADDLEBAG
INSTRUCTIONS FROM HERE ON ARE FOR COMPLETE KITS ONLY**

SPEAKER HARNESS INSTALLATION

(Read electrical connections prior to connecting center power and ground wires)

- 1) Remove the screw holding seat and remove seat.
- 2) Disconnect battery (negative cable first!)
- 3) Remove outer faring cover by removing the 7 screws holding it on.
- 4) Remove side panel cover

- 5) Route long speaker wires from fairing area through tank channel to seat area.
- 6) Route one pair of speaker wires under the frame to come out in the area where you pulled off the side panel; purple and purple and black wires to the right and green and green and black wires to the left.

AMPLIFIER INSTALLATION

Factory installed electronics will determine suggested placement of amplifier, but you can generally place the amp between the speedometer and the tachometer gauges. Relocate OEM connectors if needed and wire tie amplifier to main OEM wire harness near the speedometer.

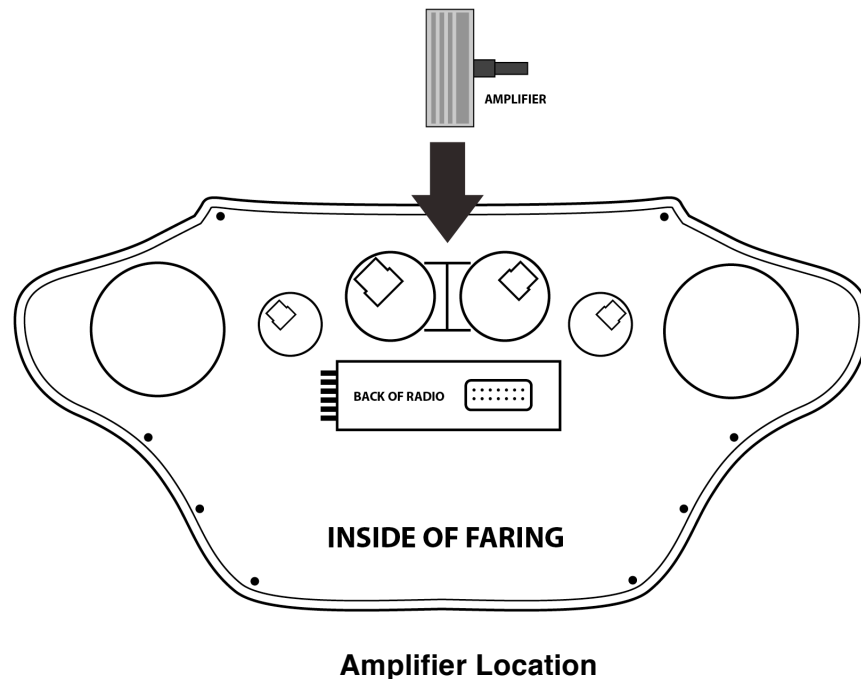

SPEAKER WIRING INSTALLATION

1) Drill Holes & Insert Grommets

A 1/4" hole must be drilled into each saddlebag for running the speaker wires to the speakers. Holes can be positioned at the owner's discretion, but the holes should be placed in a location that is discrete when the bag is mounted on the bike. After drilling holes place the provided grommets into the drilled holes before running any wires.

2) Connect Speakers

Take the short piece of sleeved wire and attach the terminal connectors to the speaker. The larger connector attaches to the green wire and the smaller to the black wire. Use the small adhesive wire tie mounts along the inside of the bag to secure your speaker wires

using the 4 inch wire ties supplied in your kit. Now **push the wire through the grommet from the inside**. Use WD-40 or a similar lubricant to make it easier to push the wire through the grommet.

3) Route Rear Speaker Wires

Remove the side panel below the seat to gain access to route the speaker wires. Set the bag into place while routing wires taking care to keep away from all moving and high temperature parts. Attach bag back to the bike by replacing the 2 mounting pins.

4) Attach Front/Rear Speaker Wire Quick Connects

Take the **2 mating connectors (male/female)** provided in the kit and **attach to wires** that come from the front (**amplifier**) and from the bag (**speaker**). When securing these wires to the connectors you must **unclip the keeper door on the back of the plugs** before sliding the wire pins into the connectors. When pinning the wires into the connectors **make sure that the pins snap into position** and will not pull back out. Once wires are pinned correctly close the keeper door on the plug.

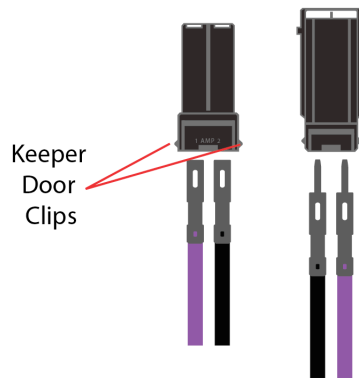

Attach Front/Rear Speaker Wire Quick Connects

ELECTRICAL CONNECTIONS

1) Connect Speaker Wires:

Speakers must be connected as follows: attach **green/black** wire connector to the **green/white** connector on the amp. Then attach the **purple/black** wire connector to the **blue/grey** connector on the amp. See drawing below.

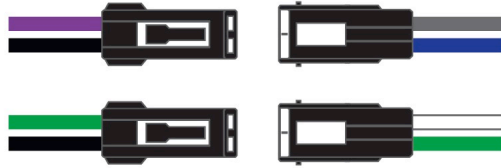

Speaker Wire Quick Connects

2) Locate Accessory Power:

Using a multi-meter, locate the **12-volt accessory power wire** or consult your local Harley- Davidson dealer to verify location of accessory wire for your particular model. Most Harley touring bikes have an extra positive and negative accessory wire usually taped near the 3-prong headlight connector.

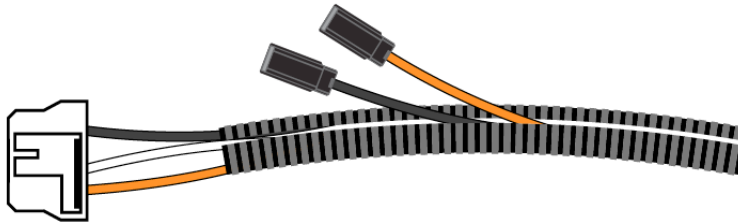

Headlight Plug Accessory Power in Harness

3) Determine Power/Ground on Bike:

Using a multi-meter determine which connector on the bike is power and which is ground. Cut off the 2 pins on the power harness and crimp the **BLUE T-Tap Inserts** to the **red and black wires**. Then connect the red and black wires on the power harness to their proper connections on the bike (**red=power/black=ground**).



Crimp Blue T-Tap Connectors

Connect to OEM (Power/Ground)

If there is already an accessory connected to these wires on the bike find an **alternate accessory power location** and use both the **BLUE and RED T-Tap electrical connectors** in combination to make the power and ground connections. See drawing below.

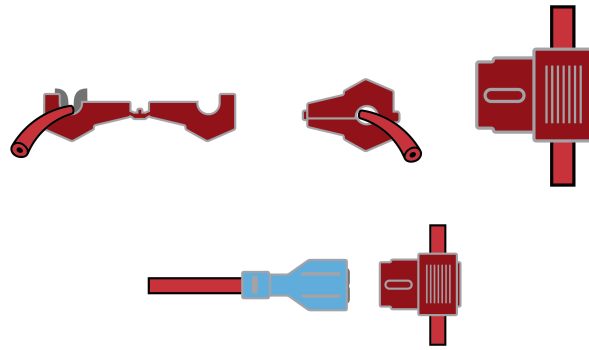

T-Tap Wire Connectors

4) Connect Amplifier:

Next, plug the **male (red/black)** connector on amplifier harness into the **female (red/black)** connector on the power harness.



Amplifier Power/Ground Quick Connects

5) Connect Audio Output Adapter:

The SNI-35 output adapter (black box) connects to the factory front speaker wires. Connect the **left factory speaker wires to white wires** and the **right factory speaker wires to the gray wires**. Then, connect RCA adapters from amplifier to SNI-35 and plug into amplifier headphone jack.

Please refer to the SNI-35 instructions and/or Harley-Davidson manual for proper wiring.

FINISHING UP

- a) Properly secure all wiring with supplied wire ties and wire tie mounts.
- b) Check all connections before you reconnect your battery!
- c) Reinstall all factory parts that have been removed for this installation to factory specifications. Consult your factory service manual for additional information.

BEFORE PLAYING YOUR STEREO, TURN IGNITION ON; ADJUST VOLUME TO LOW AND MAKE THE FOLLOWING ADJUSTMENTS TO YOUR BASS AND TREBLE:

BASS AND TREBLE ON FACTORY H-D RADIOS SHOULD BE ADJUSTED TO 4 BARS FROM LOWEST SETTING - OR - BASS AND TREBLE ON AFTER-MARKET RADIOS SHOULD BE ADJUSTED TO *AT LEAST* -2

THESE STEPS ARE CRITICAL TO MAINTAIN THE LIFE OF YOUR SPEAKERS. OUR AMPLIFIERS ARE DESIGNED FOR RIDING ENVIRONMENTS FROM THE FACTORY SO NO ADDITIONAL ADJUSTMENTS ARE NECESSARY FOR HIGH QUALITY SOUND.

CAUTION: The speakers we recommend for use in our saddlebag bezels are water resistant (marine grade), however when washing your bike be careful not to directly use a pressure washer or spray water on the opening of the speaker grills.

If additional assistance is needed please contact Cycle Sounds at 1-866-427-2346 (toll free) or 816-525-2628.

BAGGER AUDIO™ SADDLEBAG LIDS WIRING DIAGRAM

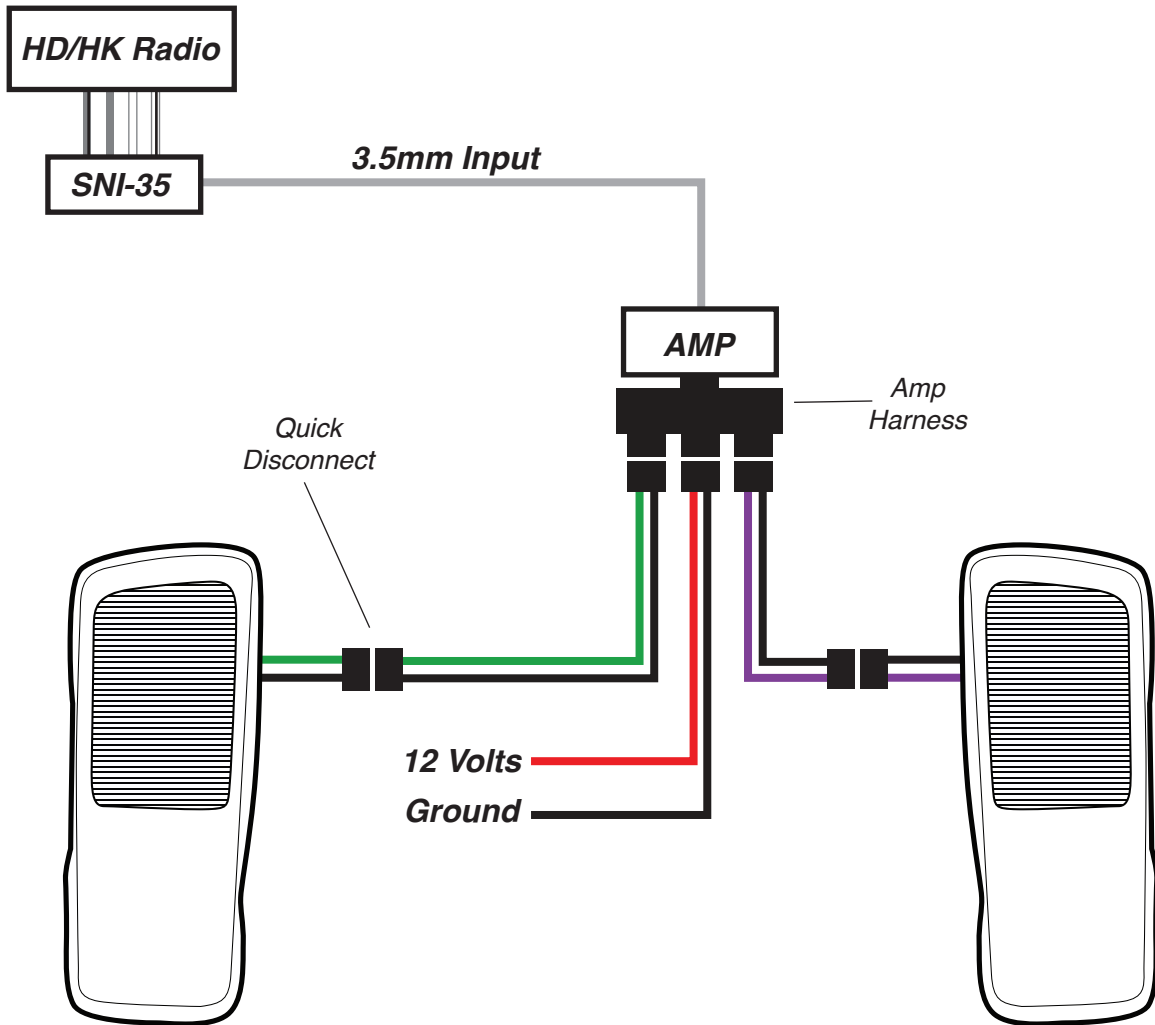

COLOR KEY:

- white wire
- grey wire
- white w/ black stripe
- grey w/ black stripe
- red wire
- green wire
- purple wire
- black wire

**SPEAKER GRILL
FABRIC PATTERN**

**SPEAKER GRILL
FABRIC PATTERN**