

INSTALLATION INSTRUCTIONS

SERIES -1 SERIES -2

GENERATION 3 IGNITION



TABLE OF CONTENTS

Section 1 INTRODUCTION

- 1.1 OVERVIEW
- 1.2 BENEFITS OF THE G3I SYSTEM
- 1.3 OPTIONS
- 1.3a TIMING CONTROLS
- 1.4 SPECIFICATIONS

Section 2 INSTALLATIONS

- 2.1 IGNITION AMPLIFIER
- 2.2 SPARK PLUGS AND WIRES
- 2.3 MOUNTING AND LOCATION OF MODULES
- 2.4 PRIMARY WIRING
- 2.5 ELECTRICAL CONNECTIONS
- 2.6 G3i MODULE TERMINAL and WIRE LEAD DESCRIPTIONS (SERIES –1)
- 2.7 MSD 6 SERIES IGNITION AMPLIFIER WIRE LEAD DESCRIPTIONS
- 2.8 G3i MODULE TERMINAL and WIRE LEAD DESCRIPTIONS (SERIES –2)
- 2.9 LEFT MAGNETO CONTACT SET (POINTS) TRIGGER SIGNAL SOURCE
- 2.10 MAGNETO MODIFICATIONS
- 2.11 CONNECTING TO MAGNETOS
- 2.12 MAGNETO TIMING

Section 3 MAGNETO MODIFICATIONS

- 3.1 SLICK 4000 & 6000 SERIES MODIFICATIONS
- BENDIX 2-10, S-200, 1200 SERIES ([See website for Bendix modification](#))

Section 4 OPERATIONAL TESTING

- 4.1 RUN-UP TESTING
- 4.2 IN-FLIGHT TESTING

Section 5 HAND STARTING

- 5.1 NON-STARTER EQUIPPED AIRCRAFT APPLICATION

Section 6 TACHOMETERS

- DIGITAL 1 & 2 CHANNEL SCHEMATICS

Section 7 TROUBLESHOOTING

- 7.1 P-LEADS TO MAGNETO
- 7.2 IGNITION COIL LEADS TO MAGNETO
- 7.3 RADIO NOISE

Section 8 DRAWINGS

- DRAWINGS TERMINAL CONNECTIONS & APPLICATION DESCRIPTIONS
- ([See website for additional drawings](#))

Section 9 ILLUSTRATIONS

- 9.1 RG 400 & P-LEAD ASSEMBLY PROCEDURES

PARTS LIST

Generation 3 Ignition, G3i interface module kit contains the following items to convert and connect both left and right magnetos to G3i module. The left magneto contact set (points) are used as the trigger signal source. Timing components, Crank Triggers are sold separately.

- (1) G3i installation Manual
- (1) Series-1 G3i Module (package) or Series-2 G3i Module
- (2) RG400 coax cables 5ft length, BNC terminated (Coil Leads, Left & Right)
- (3) 18-awg shielded P-Leads 5ft length, BNC terminated (P-Lead input/output, Left & Right, Aux.)
- (1) Terminal Strip Hardware
- (2) Magneto Modification Coil Terminal Stud Hardware kits
- (1) Toggle Switch SPST On/Off & LED
- (1) Complete packing list of itemized terminal hardware

Additional components and services available

SECTION 1 INTRODUCTION

This manual covers the installation of the Generation 3 Ignition (SERIES -1 and SERIES -2) systems. It also covers the interface modifications of the Slick magneto systems (see website for Bendix magneto systems). Included is an overview of the concept and design philosophy, installation instructions, testing procedures, troubleshooting guidelines, and the repair and warranty instructions for these systems.

The Generation 3 Ignition system was designed to interface with one or two magnetos on home built experimental aircraft.

1.1 OVERVIEW:

Generation 3 Ignition is the first add-on, interfaced-based electronic ignition control system. The G3i module interfaces with most Slick & Bendix aircraft magnetos. The G3i system provides redundant magneto based ignition as a backup in case of electrical power outages or electronic ignition failure. The G3i module interfaces the aircraft magnetos with (MST) Multiple Sparking Technology ignition system. G3i compliments the synchronized firing event in all naturally aspirated and supercharged Lycoming & Continental engines. The MST amplifier discharges synchronized multiple sparks, which lasts for 20° of crankshaft rotation.

The G3i system operates by switching the magnetos from their typical normal state to the more versatile electronic MST ignition. When the G3i module is activated, it receives a primary signal from one of the existing magneto contact points or a magnetic crankshaft trigger, depending on the application. The most common setup is the left magneto is the timing signal for both magnetos when the system is active. The signal is picked up by the G3i module and then sent to the MST ignition. The MST amplifier receives this information, processes it and sends primary spark energy back through the G3i module to excite the left and right magneto coils in perfect firing synchronization. Consequently the magnetos have all the benefits of an electronically controlled multiple spark discharge system. When the G3i system is turned off, the G3i module switches to default (no required power) and the magnetos revert back to their normal, original configuration.

1.2 BENEFITS OF THE G3I SYSTEM:

On start up, the G3i module will receive the signal from the retard or normal contact points depending on whether or not there is a impulse coupler retard lag. The G3i module will automatically excite the MST ignition amplifier to serve as a hot multiple spark discharge to BOTH magnetos at 20° of crankshaft rotation while cranking. There is no need for a shower of sparks vibrator or Slick start. There are many start up and retard configurations to choose from. After the start up, there will instantly be a much smoother idle with the system on. Both magnetos will fire together in perfect sync. Fuel consumption will be reduced significantly in most cases 6% to 14%. Starting will be much easier, whether hot or cold, or with fuel-fouled plugs. You'll see overall smoother engine operation, faster climb rates, less carbon build up in the cylinders and on the valves, plus better compression percentages. Spark plugs will burn much cleaner and be less susceptible to fouling. Additionally, there will be almost no magneto contact set (points) wear.

The G3i system can be activated by toggle switch. When powered up, the original functions of the aircraft ignition switching, key style or toggles, are not affected. The original switching will still control the left and right magneto operation. The G3i system power toggle can be turned on and off in flight without causing a miss-firing event. With the engine loaded and speeds above 1500 rpm's, switching the G3i system on and off line, it is normal to have a very slight interruption as the system switching occurs.

1.3 OPTIONS:

Generation 3 Ignition systems offer two systems. Series –1 and Series –2. Series -1 is a modular set-up where the amplifier and G3i module are separate allowing more mounting versatility in tight areas. Where as the Series –2 is all in one module. Both systems have the exactly the same current requirements and out-put specifications. The G3i systems have auxiliary timing inputs for start up and run modes, which can be configured to your requirements.

1.3a TIMING CONTROLS:

The Series –1 and Series –2 systems also have the unique ability to be configured with many different MSD ignition-timing components and configurations utilizing the stock magneto contact points (most common), or with an optional crankshaft trigger sensor. For interfacing timing controls and crankshaft trigger set-ups go to www.g3ignition.com to download printable pdf files for further explanation, drawing schematics, and detailed terminal connections.

1.4 SPECIFICATIONS:**SERIES –1: Modular******G3i MODULE:**

Any number of cylinders

Drives 1 or 2 magnetos in synchronization

Aircraft ignition switching, LEFT, RIGHT, BOTH, START

Signal: Contact set (points), Magnetic Pickup, Crankshaft trigger

Auxiliary timing & starting inputs

Operating voltage: 9 –18 VDC, Negative ground

Current requirements: 0.7 AMPS

Recommended operating temperature: -40°f - +185°f.

Weight and size 1.75 LBS. Foot Print 4.0"L x 6.5"W x 2.25"H

*Requires ignition amplifier

***AMPLIFIER:**

Capacitive discharge, MSD 6 series ignition

Multiple spark duration: 20 degrees of crankshaft rotation

Operating voltage: 9 –18 VDC, Negative ground

Current requirements: Average of 1.0 AMPS/ 1000 RPM

Voltage output: Primary 460 – 480 volts

Recommended operating temperature: -40°f - +185°f

Weight and size: 2.75 LBS. Foot Print 8"L x 3.5"H x 2.25"H

SERIES –2:

Complete all in one system including internal filters

Any number of cylinders

Drives 1 or 2 magnetos in synchronization

Aircraft ignition switching, LEFT, RIGHT, BOTH, START

Signal: Contact set (points), Crankshaft trigger

Auxiliary timing & starting inputs

Operating voltage 9 –18 VDC, Negative ground

Current requirements 3.7 AMPS @ 3000 RPM

Recommended operating temperature: -40f to +185°f

Weight and size 4.1 LBS. Foot Print 8.625"L x 6.5"W x 2.25"H

SECTION 2 INSTALLATIONS

Caution: Operating the ignition without all connections completed can result in damage to the ignition system, other components and/or cause electrical shock.

2.1 IGNITION AMPLIFIER:

The ignition amplifier of choice is the MSD 6a. The MSD 6a installation instructions can be used for additional reference with the installation of the G3i system. The G3i modules will interface with most all MSD ignition configurations.

Note: Connecting power directly to the battery or the cold (switched side) of the master solenoid will reduce the chance of instrumentation/radio interference.

2.2 SPARK PLUGS AND WIRES:

Original aircraft ignition harness and spark plugs can be used with the G3i ignition and MSD 6a. MSD recommends, “not to use solid core spark plug wires” these are of the automotive style “ they have no outer shielding”. The aircraft ignition harness (spark plug wire) is a solid core, and is designed with a high quality outer shielding with very minimal electro magnetic interference (EMI). This will not interfere with the operation of the G3i module or MSD 6a. The magneto ignition harness cap can be modified to accept automotive leads. Which will allow a wide range of spark plug boots and terminal ends and automotive type spark plugs with inserts. It is recommended to follow the spark plug manufacture’s specification for spark plug gaps. The most common total spark plug air gap is increased to .020” to .026” depending on the spark plug type and compression ratio.

2.3 MOUNTING AND LOCATION OF MODULES:

The Series –1 G3i module and the MSD amplifier can be mounted together on an aluminum plate in a clean dry place away from engine heat. Preferably located on the backside of the engine firewall. For engine compartment mounting, connections of the G3i module should be orientated to the side or facing down. Depending on location in the engine compartment, a cover should be fabricated to protect the G3i module and MSD amplifier from water and solvents. Blast tubes can be added and routed for cooling concerns if necessary. The color-coded leads that come out of the G3i Series –1 module connect as depicted in the drawing, to the same color and gage on the MSD 6a amplifier.

Note: Follow the same mounting location requirements for the Series –2 “all in one” module.

Note: Maintain a 6” to 8” minimum distance of modules or amplifier from radios if possible.



RV-6 Series -1



RV-7 Series -2

2.4 PRIMARY WIRING:

The primary wires supplied with the G3i module are of a high quality aircraft shielded wire. The P-Leads are shielded 18-gauge and the primary ignition coil leads are RG400 coax. All leads are 5ft in length and are supplied with a BNC connection at one end. You will cut these to your specific lengths to route to the proper location on the magnetos. Then strip the center conductor for the ring terminal and fold back the braided shield to provide as a ground. Crimp the proper size ring end terminals to the center conductor and shield ground on the lead.

Note: RG 400 and P-Lead step-by-step assembly procedures are located in Section 9 ILLUSTRATIONS 9.1



P-leads connected to G3i module.

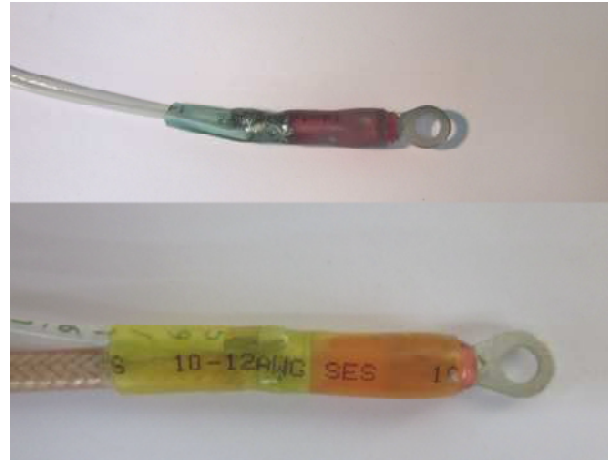

Magneto ring terminal connections soldered-heat-shrink with the shielded ground pigtail.

WARNING

DISCONNECT BATTERY DURING INSTALLATION TO AVOID ANY POSSIBILITY OF AN ELECTRICAL SHORT OR SHOCK.

2.5 ELECTRICAL CONNECTIONS:

The Series -1 G3i module draws .7amps, and the MSD will draw an average of 1.0amps per 1000 rpm. Series -2 G3i module will be the same total current draw averaging of 3.5 to 4amps. When connecting the large lead from the MSD 6a amplifier or Series -2 module, a good location is the cold (switched side) of the master solenoid. Connecting the power close to the battery will reduce the chance of instrumentation/radio interference. The power toggle switch can be also wired independently with the use of 18-awg wires. Locate the supplied LED/lamp next to the G3i module power toggle or the instrument panel for displaying the G3i system on. See input wiring diagrams for your specific application. Over voltage protection must be used on any electrical system.

Note: Powering the complete system (all modules) through the avionics bus will possibly create radio and/or instrument interference.

Note: When connecting the heavy red to the battery or a hot power source for the first time you may see an initial spark as the connection is made. This is a result of the cap filter being charged. To verify this remove the positive lead and reconnect, there should be no spark.

2.6 G3i MODULE TERMINAL BLOCK and WIRE LEAD DESCRIPTIONS: SERIES -1

Terminal block (T1 thru T9):

- (T1) Switched 12-volt power in. Turn on/off G3i system (18-awg)
 (T2) 12-volt switched power in from starter switch or starter solenoid. Only hot when starter switch is engaged. This will activate G3i system if main G3i toggle is off during starting only (18-awg).
 (T3) Left in-put p-lead from original left p-lead ignition switch terminal or left ignition toggle terminal.
 (T4) Common shield ground for left and right p-leads from ignition switch terminal or Left/Right ignition toggle terminals.
 (T5) Right in-put p-lead from original right p-lead ignition switch terminal or right ignition toggle terminal.
 (T6), (T7), (T8), (T9) Bridge terminals for configuring Series -1 G3i module timing in-puts locations for different applications.

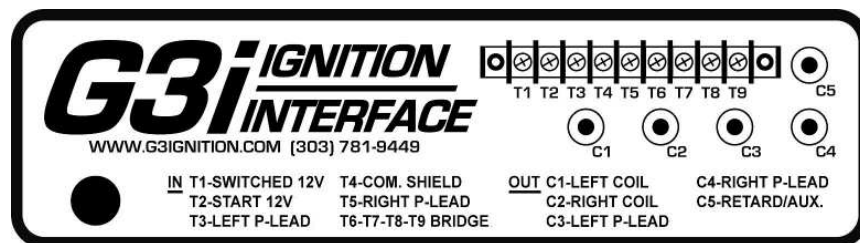

Series -1 Module decal legend

BNC Connections (C1 thru C5):

- (C1) Left coil out-put BNC to left magneto coil stud terminal.
 (C2) Right coil out-put BNC to right magneto coil stud terminal.
 (C3) Left p-lead out-put BNC to left magneto capacitor terminal.
 (C4) Right p-lead out-put BNC to right magneto capacitor terminal.
 (C5) Auxiliary BNC for timing in-put. Starting retard contacts or advance contacts signal.

Wire Leads:

- Orange lead: Coil in-put lead from MSD amplifier (18-awg).
 White lead: Timing signal lead out to MSD amplifier (18-awg). (Contact set / points signal)
 Red lead: Switched 12-volt power out to MSD amplifier (18-awg).
 Black lead: Ground lead to small Black MSD amplifier (18-awg).
 Brown lead: Negative lead for crankshaft trigger signal (18-awg).
 Black heavy lead: Main G3i module ground in-put lead (16-awg).

2.7 MSD 6 SERIES IGNITION AMPLIFIER WIRE LEAD DESCRIPTIONS:

Refer to the MSD 6 Series Installation Instructions:

Heavy Red: In-put power to MSD, connects to CB or directly to switch side of master solenoid.

Note: The MSD has an internal fuse (16-awg).

Heavy Black: Connect to a good ground (-), or battery terminal (16-awg).

Red: To G3i Module Red.

Orange: To G3i Module Orange.

Black: To G3i Module Black (18-awg).

White: To G3i Module White.

Violet and Green: Magnetic pickup connector. Violet wire is positive (+); Green is ground (-).

2.8 G3i MODULE TERMINAL BLOCK and WIRE LEAD DESCRIPTIONS: SERIES –2

Terminal block (T1 thru T10):

- (T1) Switched 12-volt power in. Turn on/off G3i system (18-awg)
 (T2) 12-volt switched power in from starter switch or starter solenoid. Only hot when starter switch is engaged. This will activate G3i system if main G3i toggle is off during starting only (18-awg).
 (T3) Left in-put p-lead from original left p-lead ignition switch terminal or left ignition toggle terminal.
 (T4) Common shield ground for left and right p-leads from ignition switch terminal or Left/Right ignition toggle terminals.
 (T5) Right in-put p-lead from original right p-lead ignition switch terminal or right ignition toggle terminal.
 (T6), (T7), (T8), (T9), (T10) Bridge terminals for configuring Series –2 G3i module timing in-puts locations for different applications.

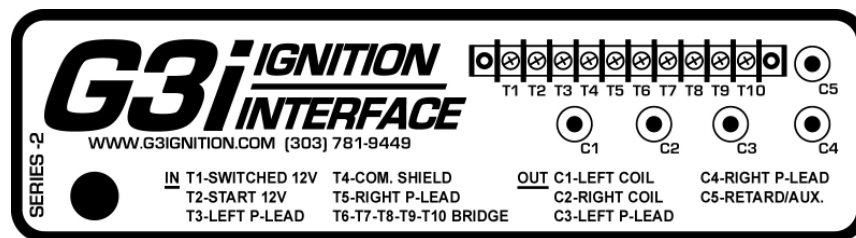

Series –2 Module decal legend

BNC Connections (C1 thru C5):

- (C1) Left coil out-put BNC to left magneto coil stud terminal.
 (C2) Right coil out-put BNC to right magneto coil stud terminal.
 (C3) Left p-lead out-put BNC to left magneto capacitor terminal.
 (C4) Right p-lead out-put BNC to right magneto capacitor terminal.
 (C5) Auxiliary BNC for timing in-put. Starting retard contacts or advance contacts signal.

2.9 LEFT MAGNETO CONTACTS SET (POINTS) TRIGGER SIGNAL SOURCE:

Listed below are the most common standard configurations using the Left Magneto as the trigger signal source to excite both magnetos. See drawings in section 8 for further explanation and detailed terminal connections.

SERIES –1 or SERIES –2

Drawing 1:

Left Magneto Normal Contacts are Trigger Source
 Left Magneto Lag – Retard Impulse Coupler

SERIES –1 or SERIES –2

Drawing 2:

Left Magneto Normal Contacts are Trigger Source
 Left Magneto Retard Contacts / Active in Start

Note: All configurations will provide a signal to G3i module that will excite the amplifier to fire both magnetos at start up. There is no need for Slick Start or Shower of Sparks. The G3i Series –1 or Series –2 systems will provide Multiple Discharge Spark when starting.

Note: ACS-510 ignition switch, in start mode, the right magneto ground jumper needs to be removed to use the right ignition also during start up.

2.10 MAGNETO MODIFICATIONS:

These following modifications must be done with good useable working magnetos. If the magnetos are in need of a rebuild or need disassembly inspection repair, then this must be done first before installing with the Generation 3 Ignition system. Magneto modifications, ignition parts and service are all available though Generation 3 Ignition if needed.

Before any work is done on the magnetos, determine the exact timing of BOTH mag's and make a note of it. Depending on the type of magnetos you have and obstructions to work around, this may require the removal of the magnetos to do the modification properly. Before the magnetos are removed, take a good look at the amount of space around the magnetos. Plan the location of the ignition coil drive stud before installing it to prevent interference with any existing engine accessories.

A qualified technician familiar with aircraft ignition systems should /can be consulted to do this modification. Follow the modification procedures for your specific magneto application. See illustrations (Section 3).

2.11 CONNECTING TO MAGNETOS:

The left and right ignition P-leads are removed from the original magneto connection and now routed to their perspective location on the G3i module terminal strip connection. The new BNC white shielded P-leads supplied with the BNC connectors are now routed back to the left and right magneto P-lead connections along with the RG400 coax cable to the coil driver stud on the magneto. For the non-impulse coupling magneto with retard contacts, the retard terminal on the magneto will be the third BNC white P-lead will be routed to the AUX BNC (C5) connection on the G3i module. This is the retard signal for starting. AUX. BNC (C5) also can serve as an alternate timing input. There is no need for the Slick start or Bendix shower of sparks. The G3i system will excite both magnetos when in starting mode. The primary ignition wires/coax can be routed together. These are not affected by other engine wiring.

Note: See Section 8 for the most common applications and drawings.

Note: See www.g3ignition.com for more specific applications.

2.12 MAGNETO TIMING:

After the magnetos have been re-installed, and with the spark plugs removed, switch the G3i system to OFF and the magnetos switched to hot. The magnetos can be re-timed as in a normal configuration with a dual magneto synchronizer timing light tweeter. Follow your engine manufacturer's timing specifications. BOTH magnetos MUST be in synchronization.

Note: The G3i ignition amplifier will have a (.5 to 1 degree) delay from where the magneto timing is set when the G3i system is on.

SECTION 3 MAGNETO MODIFICATIONS

This section covers the most common modification for Slick magnetos. Other Slick and Bendix modifications are available in pdf form to view and print @ www.g3ignition.com. The main factor to keep in mind is the location of the coil terminal stud. Prevent any chance of the terminal grounding out on/in the magneto housing and/or other magneto components. Keep all wires clear of any rotating parts and where there is any chance of wire chafing. The following modification examples are performed off the aircraft. A qualified technician familiar with aircraft ignition systems should do this modification. Follow the modification procedures for your specific magneto application.

3.1 SLICK 4000 & 6000 SERIES MODIFICATION:

This section the most common modification examples on the installation of the ignition coil terminal stud into the magneto the magneto main housing side. **Example 1:** The main housing side modification will not require coil lead wire to be lengthened or modified. The main factor to keep in mind is to locate the coil terminal stud and terminals away from any chance of grounding out on/in the magneto housing and/or other magneto components. Keep all wires keep clear of any rotating parts and where there is a chance of wire chafing. These modifications are performed off the aircraft. A qualified technician familiar with aircraft ignition systems should do this modification. Follow the modification procedures for your specific magneto application.

EXAMPLE 1: Main Housing Side location

1. Remove the top cover to gain access to the coil lead that is connected to the contact points. Remove both the capacitor and coil leads from the contacts. (Image 1d, 2d, 3d, 4d)



Image 1d



Image 2d



Image 3d



Image 4

2. It will be necessary to remove the distributor cap/rotor assembly. (Image 5d)



Image 5d

3. For reference and showing the general area of the lower part of the main magneto housing. This is the area where the ignition coil terminal stud will be located. The depth to the casting shelf measurement is 1.00". The distance from the casting step to the center of the distributor cap screw hole is also 1.00". (Image 6d, 7d)



Image 6d

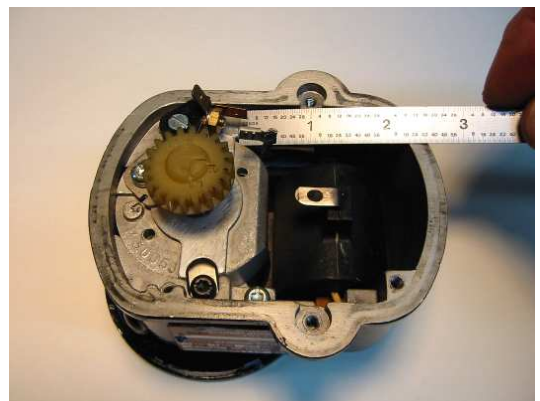

Image 7d

4. The preferred location of the new coil terminal stud will be here. The distance shown from the center of the distributor cap screw hole is .625". Also the distance from the top face is .625". Center punch and drill a hole sized to .250" (Image 8d, 9d)

Note: The indexed center punch mark for drilling.



Image 8d

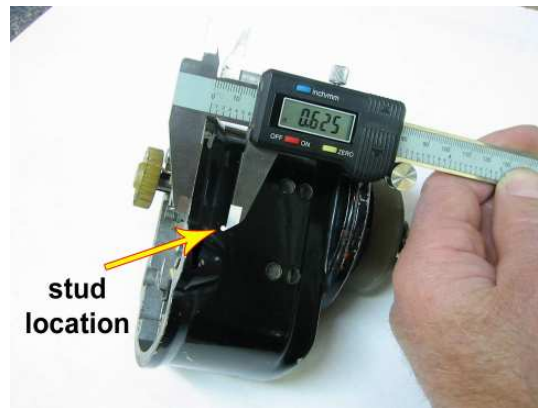

Image 9d

5. An outside/inside view of terminal location. (Image 10d, 11d)



Image 10d



Image 11d

6. The hardware is layout in order for the ignition coil terminal stud into the lower part of the main magneto housing. The male spade stud terminal will need to be modified. The male spade will need to be trimmed to a width of .187" to accept the original coil female terminal. Then bend the male spade to a 20° to 30° angle as shown. (Image 12d)



Image 12d

7. Coil terminal stud installed with male flag terminal. Just snug, do not final tighten. (Image 13d)
Note: Between the two insulating shoulder washers at the magneto housing place a small amount of two-part epoxy for extra rotation resistance on stud.
8. Install the coil female terminal to the male spade terminal. (Image 14d)



Image 13d



Image 14d

9. Rotate the connected coil terminals to the 3 o'clock position, gently routing the coil wire into a small loop. (Image 15d)
10. Now finish tightening the coil terminal stud assembly. Tighten to 20 - 25 in.-lbs. (Image 16d)

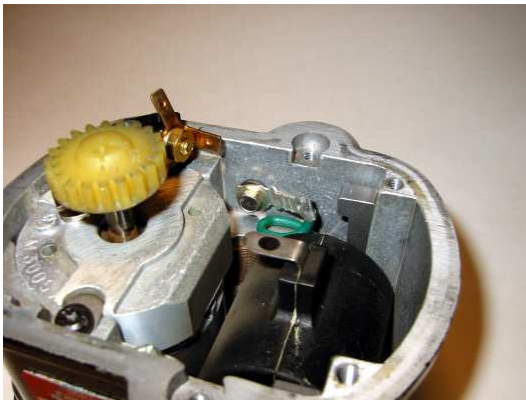

Image 15d



Image 16

11. Re-install the index distributor cap/rotor assembly to the shaft gear. Torque distributor cap screws to 18-28 in.-lbs. (Image 17d)
Note: If a Slick timing pin is not available, a #42 or .093" drill bit will do.
12. Re-connect the capacitor lead to the contact set. This will be the only connection to the contact set. Install top cover housing screws, torque to 18-28 in.-lbs ready to install. (Image 18d)
Note: Clean magneto housing of all drill chips and any type of contamination with compressed air before reassembly.



Image 17d



Image 18d

SECTION 4 OPERATIONAL TESTING

Before starting, insure the wiring is securely fastened, and the modules are mounted securely and are in an area free of transmitted engine vibration. Check all routing and make sure leads are away from any chafing and exhaust heat. With the system connected and master switch on, G3i system toggle switched on, the green LED/lamp will illuminate. With the G3i toggle in the off position, the LED/lamp will illuminate when in crank/start mode if wired (terminal T2). This will show that the system is active when in start mode powering up the G3i system. This will provide both magnetos in proper retard time with a multiple discharge spark on each compression stroke at startup. The G3i system toggle can be on or off when starting. If the G3i toggle is off while starting, the ignition system will automatically revert back to the normal magneto mode once the starter switch is released. The engine will continue to run. At this time you can switch the G3i system on.

Note: Terminal (T2) can be left open so that the G3i is not activated during starting. Starting will be from standard magneto impulse coupler spark energy. Just turn on the G3i power to use EI on starting.

NOTE:

In flight loss of engine power from suspected G3i ignition system failure, Toggle off the power to the G3i ignition system to revert back to default magneto mode.

4.1 RUN-UP TESTING:

After the start up, there will instantly be a much smoother idle with the system on. Both magnetos are firing together in perfect synchronization. With the G3i system on during run up, go to the suggested specific rpm for setting the mixture and continue with the normal ignition cycling from both, left, right, checking for rpm drop. If the fuel mixture is near optimum, there will be much less rpm drop and the exhaust note will not sound as lazy. Next switch the G3i system off and repeat the ignition cycle, both, left, right, in normal magneto mode. Remember this is the back up mode.

4.2 IN-FLIGHT TESTING:

The G3i system can be turned on and off, and cycled left and right in flight. Turning off the system will verify that the magnetos are still functioning in their normal back up mode. When the G3i system is coming back on line it is normal to have a very slight rpm interruption as the system is powered up in the higher rpm range. Lean as normal as suggested by your engine manufacture settings. Verify that all cylinder head temperatures are within normal operating limits.

SECTION 5 HAND STARTING

WARNING:

5.1 NON-STARTER EQUIPPED AIRCRAFT APPLICATION:

The engine must have at least 1 retard lag impulse-coupled magneto.

Do not attempt to hand prop start your engine. Do this only if you are completely trained and competent with hand prop starting procedures. The following is not a complete thorough guide or recommendation on how to safely hand prop start your engine.

Hand starting is to be used if your aircraft is non-starter equipped or battery is low and you're not able to crank the engine. By using proper safe hand starting procedures. ***The engine must have at least 1 retard lag impulse-coupled magneto.*** Hand prop starting can be performed in a safe normal manner with the G3i system OFF. Once started and running on the magnetos, the G3i system may be turned on.

Note: Always start with the G3i system off.

WARNING:

Always have the G3i system OFF when hand starting. The retard lag impulse-coupled magneto switch to on. Always remain clear of the propeller when turning off or on the G3i system, resulting in a backfire and possibility of severe injury

WARNING:

Never turn the engine backwards with the magnetos and the G3i system ON. The G3i system will see the pulse signal from the magneto trigger points and fire both magnetos resulting in a backfire and causing severe injury!

WARNING:

Initial spark can occur when the G3i system is turned OFF or ON and powers up the ignition Amplifier. This can result in a backfire and the of severe injury. Always remain clear of the propeller when turning OFF or ON the G3i system.

Follow all hand starting safety procedures when hand starting. Leave the magneto switches OFF and G3i system OFF until when ready to pull through the compression stroke to start. Always remain clear of the propeller when turning ON or OFF the G3i system. Otherwise all switches remain off until ready.

Note: When the G3i amplifier remains a sleep mode until it receives 2 to 4 timing signal pulses before it will fire the spark plugs.

THIS PAGE LEFT BLANK INTENTIONALLY

SECTION 6 TACHOMETERS:

Tachometer signal supplied from the G3i Series -2 Module or MSD 6a amplifier is a clean 12-volt, square wave signal with a 20% duty cycle. This reference signal is produced with every firing event. NOTE: The magneto p-lead should never be connected to the G3i Series -2 module or the MSD 6a tachometer signal out-put terminal. DAMAGE WILL RESULT to the MSD Amplifier. After completing the installation of the G3i system, when turned on the digital tachometer reading will usually display twice the engine rpm. Most late model engine instrumentation with digital tachometers are set up for magnetos and read every other firing event. This usually can be reprogrammed to accept this every fire event reference signal to get the correct rpm reading for your digital tachometer. Refer to your install manual or contact your specific engine-monitoring manufacturer for reprogramming procedures. See drawings B1 & B2 for additional wiring schematics on connecting 1 channel digital tachometers. SPDT-SW and DPDT-SW power toggle switches are available through Generation 3 Ignition. A good alternative for providing an isolated "pip/tach" signal to digital tachometers is the UMA (T1A9) sending unit for tachometers. These sensors screw into the existing magneto (Slick or Bendix) side vent hole. We will do our best to provide tachometer troubleshooting and/or customer support on this topic.

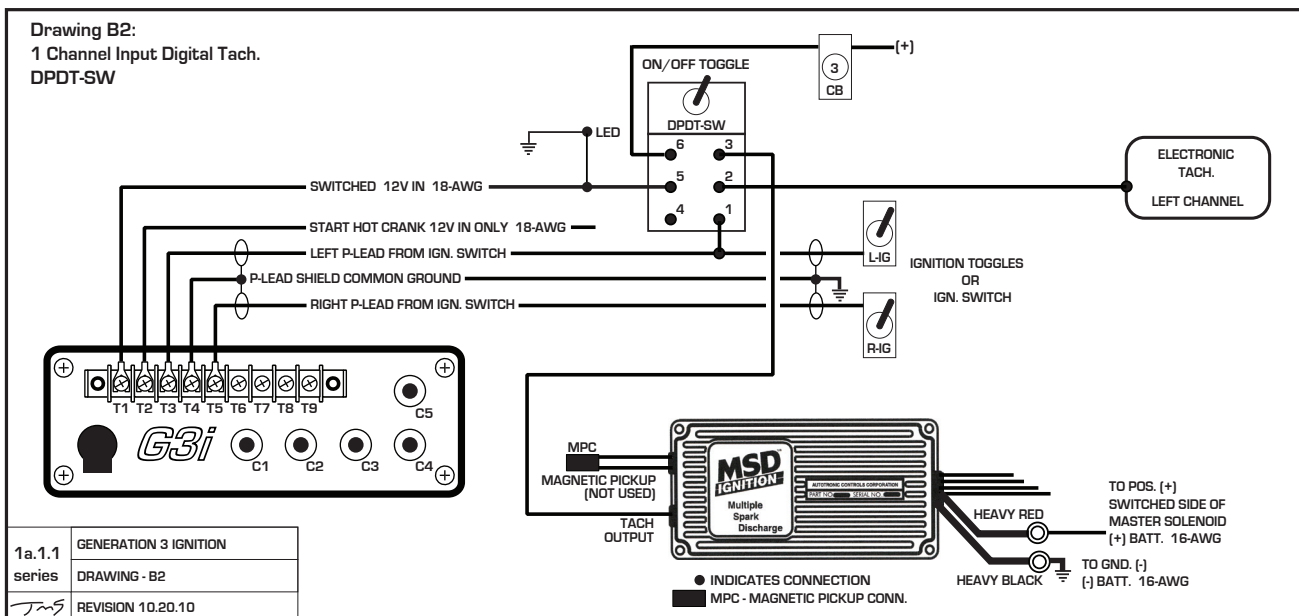
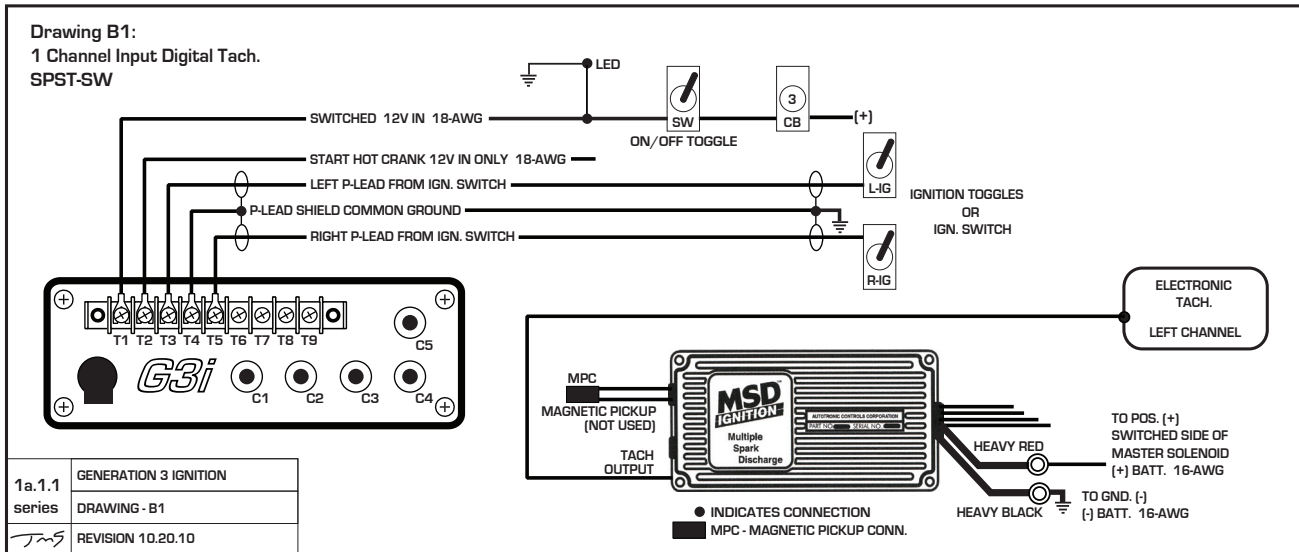

SECTION 7 TROUBLESHOOTING:

All Generation 3 Ignition systems and components undergo a series of functional tests prior to delivery. The G3i modules are dyno tested from 1 to 3600 crankshaft rpm with magnetos and a MSD 6a amplifier in all modes to ensure proper operation. If you have any question concerning your G3i ignition system, contact our tech support via email mail@g3ignition.com or at 303-806-5120, Monday thru Friday 7am - 3pm Mountain Time.

The most common installation failures are the incorrect connection of the BNC C-terminals on the G3i module and the signal P-leads and/or ignition coil terminal leads. Double check the wiring diagram and insure proper connection locations.

7.1 P-LEADS TO MAGNETO:

All P-lead and ignition coil terminal leads can be checked with the use of an ohmmeter when disconnected at both ends. The BNC center conductor will show no conductivity to the outer shield. Also on the center conductor of each lead from one to the other will have very little to no resistance.

P-lead center conductor from the magnetos will have continuity to ground when the points are closed and no continuity when the points are open..

7.2 IGNITION COIL LEADS TO MAGNETO:

Ignition coil lead center conductor from the magnetos will have .4 to 1.0 ohm continuity (this will vary on type of magneto) to ground at all times through the coil primary windings when connected to the magneto. If this shows open, first check the ignition coil lead for open. If the lead checks out ok, then test at the coil terminal stud to ground to see if the open is there. Then there is an open between the coil terminal stud and primary lead to the coil inside the magneto.

Verify ignition coil lead grounded at all times. Check lead first for continuity to the shield. This will be open. Next check coil stud terminal to ground, if grounded, there is improper stud installation.

7.3 RADIO NOISE:

If there is radio interference and/or erroneous engine monitoring discrepancies that go away when the G3i system is turn off. Check proper grounding pigtails on the P-leads and/or coil leads at the magneto. Maintain a 6" to 8" minimum distance of G3i Series-1 module and amplifier or Series-2 module from radios if possible. The noise filter capacitor is installed (Series-1). Series-2 is internally cap filtered.

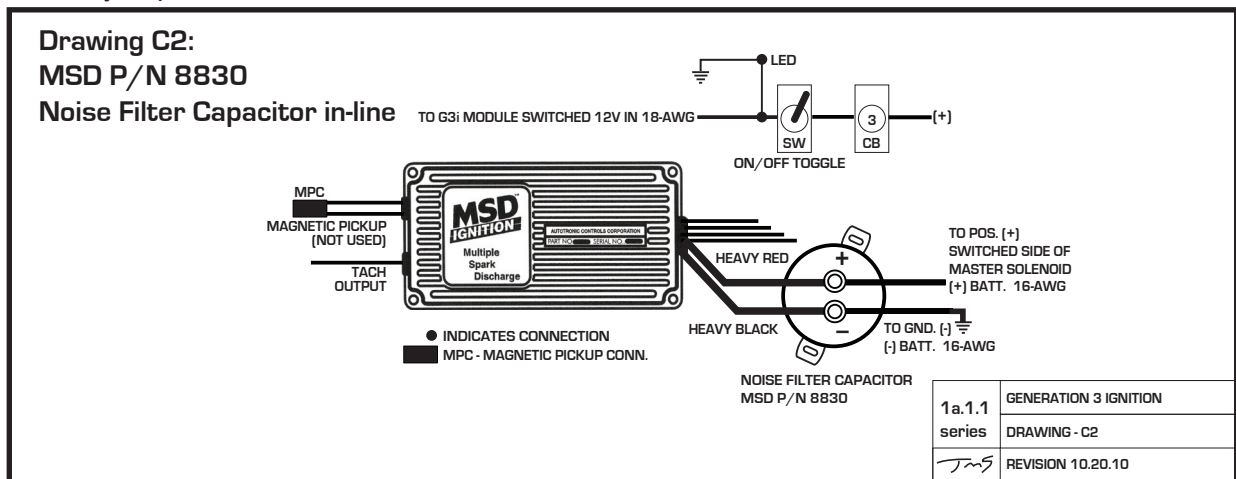

SECTION 8 DRAWINGS:

SERIES -1

Terminal connections and application descriptions:

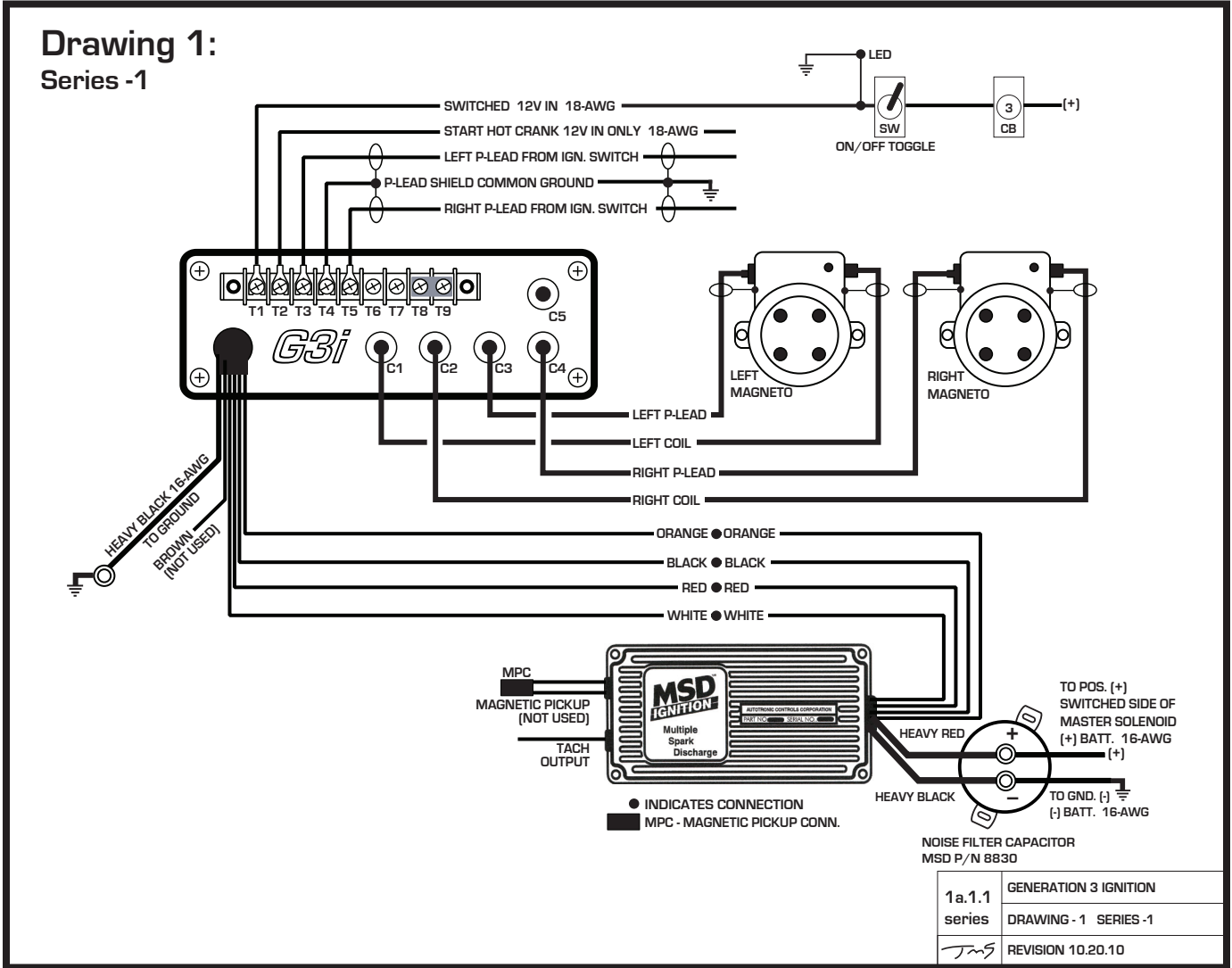

**Left Magneto Normal Contacts are Trigger Source
Left Magneto Lag - Retard Impulse Coupler
*** BRIDGE TERMINALS (T8 - T9) *****

The left magneto's normal contact set (points) will serve as the trigger source in the electronic ignition mode also. The Left magneto's impulse coupler on start up will retard the signal to G3i Series -1 module that will excite the MSD amplifier to fire both magnetos at start up.

Note: ACS-510 ignition switch, in starting mode, the right magneto ground jumper needs to be removed to use the right ignition also during start up.

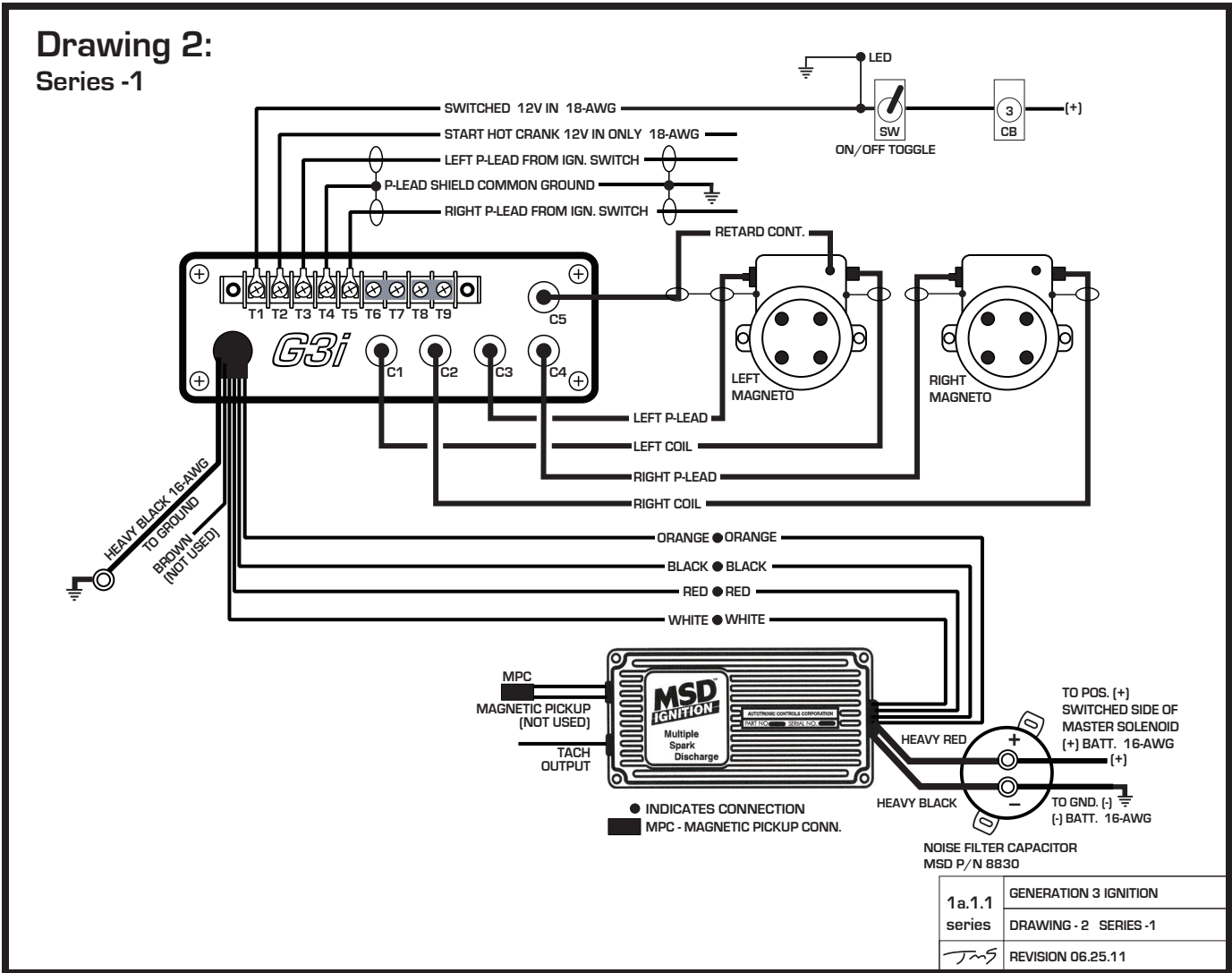

Left Magneto Normal Contacts are Trigger Source
Left Magneto Retard Contacts / Active in Start
***** BRIDGE TERMINALS (T6 - T7) (T8 - T9) *****
Retard Contact P-Lead to BNC (C5)

The left magneto's normal contact set (points) will serve as the trigger source when the G3i system is in the electronic ignition mode also. The Left magneto's retard contact set (points) is only used on start up. This will provide the retard signal to G3i Series -1 module that will excite the MSD amplifier to fire both magnetos at start up.

Note: ACS-510 ignition switch, in starting mode, the right magneto ground jumper needs to be removed to use the right ignition also during start up.

SERIES -2

Terminal connections and application descriptions:

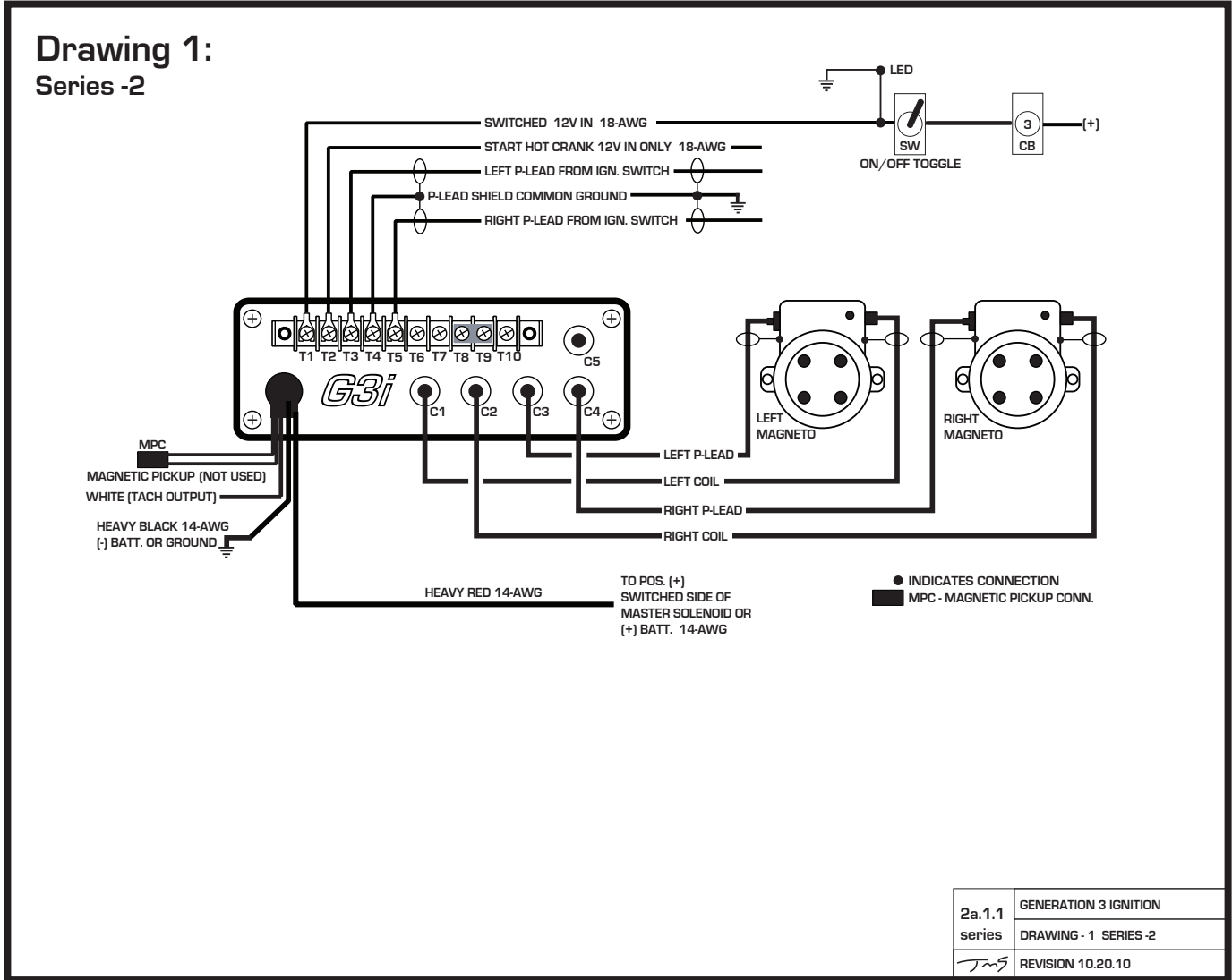

Left Magneto Normal Contacts are Trigger Source

Left Magneto Lag - Retard Impulse Coupler

***** BRIDGE TERMINALS (T8 - T9) *****

The left magneto's normal contact set (points) will serve as the trigger source in the electronic ignition RUN mode also. The Left magneto's impulse coupler on start up will retard the signal to G3i Series -2 module that will excite to fire both magnetos in a synchronized multiple spark discharge during start up.

Note: ACS-510 ignition switch, in starting mode, the right magneto ground jumper needs to be removed to use the right ignition also during start up.

Drawing 2:
Series -2

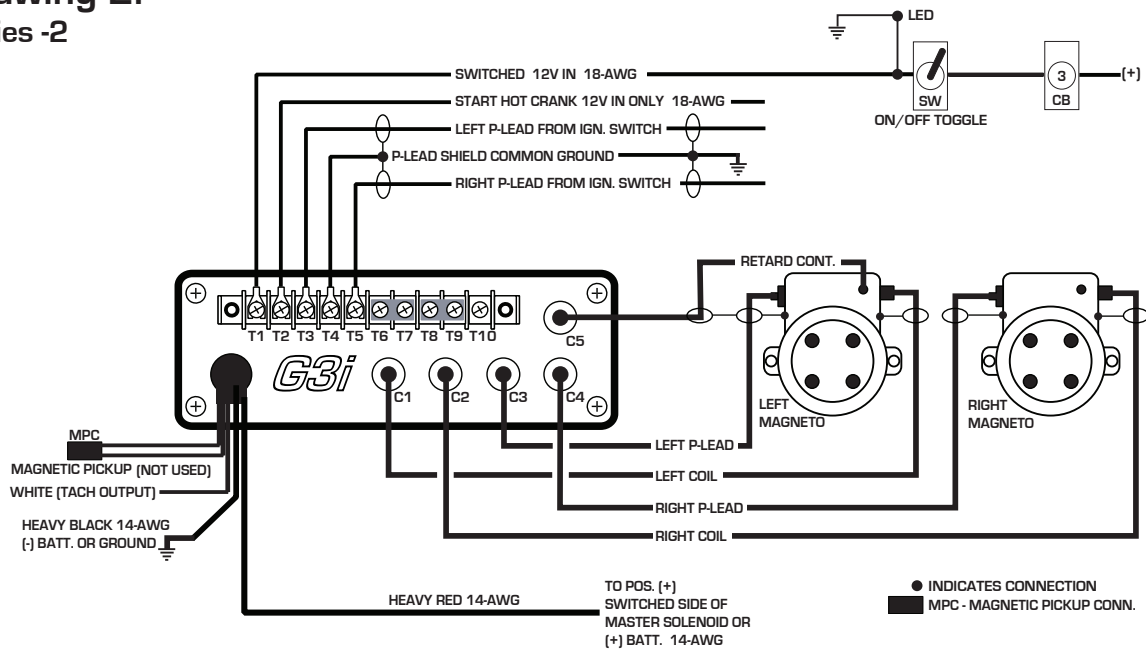

2a.1.1	GENERATION 3 IGNITION
series	DRAWING - 2 SERIES - 2
<i>JMS</i>	REVISION 06.25.11

Left Magneto Normal Contacts are Trigger Source
Left Magneto Retard Contacts / Active in Start
***** BRIDGE TERMINALS (T6 -T7) (T8 -T9) *****
Retard Contact P-Lead to BNC (C5)

The left magneto's normal contact set (points) will serve as the trigger source when the G3i system is in the electronic ignition mode also. The Left magneto's retard contact set (points) is only used on start up. This will provide the retard signal to G3i Series -2 module that will excite to fire both magnetos at start up.

Note: ACS-510 ignition switch, in starting mode, the right magneto ground jumper needs to be removed to use the right ignition also during start up.

SECTION 9 ILLUSTRATIONS:

9.1 RG400 & P-LEAD TERMINAL END ASSEMBLY PROCEDURES:

P-LEAD #10 RING TERMINAL:



1). Remove outer shielding to expose center conductor insulation and stranded center wire.



3). Install blue heat shrink sleeve and ground pigtail. Heat shrink and melt solder ring.

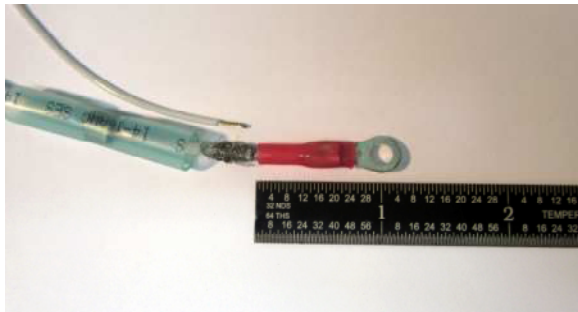

2). Slide on blue heat shrink sleeve and then #10 red heat-sealed terminal over center insulation and center conductor. Crimp terminal to center conductor and heat seal the red terminal.



4). Completed assembly heat shrunk with ground pigtail.

RG400 #8 RING TERMINAL:



1). Remove outer shielding to expose center conductor insulation and stranded center wire.

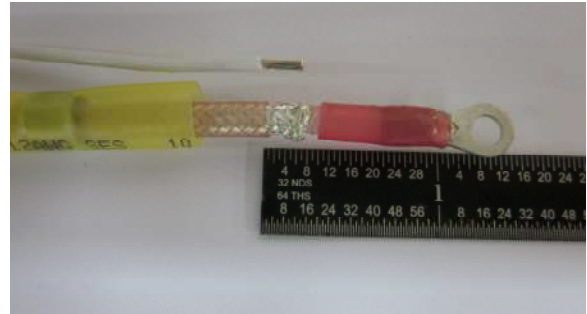

3). Terminal layout prior to final assembly.

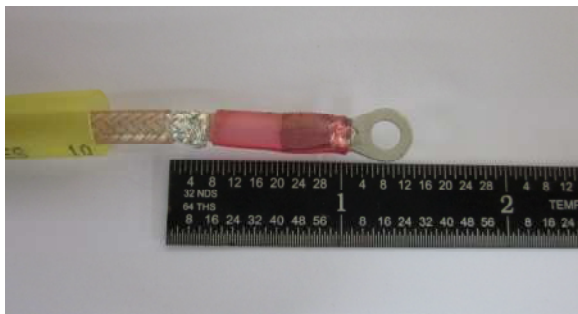

2). Slide on yellow heat shrink sleeve and then #8 red heat-sealed terminal over center insulation and center conductor. Crimp terminal to center conductor and heat seal the red terminal.



4). Install yellow heat shrink sleeve and ground pigtail. Heat shrink and melt solder ring.



5). Completed assembly heat shrunk with ground pigtail.

NOTICE

Generation 3 Ignition systems must be installed with good useable working magnetos. If the magnetos are in need of a rebuild or need disassembly inspection repair, then this must be done first, before installing the G3ignition system.

Magneto modifications, ignition parts sales and service are available though Generation 3 Ignition if requested.

WARNING

Failure of the G3i ignition system or products, or improper installation of the G3i ignition systems or products, may create a risk of property damage, severe personal injury or death.

WARRANTY and LIMITATION OF LIABILITY

Generation 3 Ignition systems are warranted to the original purchaser for one full year from the date of purchase against defects in material and workmanship. During this period, Generation 3 Ignition will repair or replace G3i modules within the warranty period that, in Generation 3 Ignition's sole opinion, that have not been subjected to abuse or any attempted field repairs. This warranty is limited to the purchase price of Generation 3 Ignition hardware and does not cover the engine or other engine components that may be affected by defects or failure of the system, and Generation 3 Ignition shall not be liable for any obligations or liabilities whatsoever, or any strict liability theory.

Generation 3 Ignition hardware is intended only for installation and use on experimental aircraft, which are licensed by the FAA in the "EXPERIMENTAL" category pursuant to a Special Airworthiness Certificate. All products must be installed and used in accordance with the current installation manual by experienced mechanics. The most current installation instructions are available from Generation 3 Ignition which are on the website at www.g3ignition.com

RETURNS

You can return any new or unused item within 30 days of the date your item was shipped and we will refund the full purchase price if received in re-saleable condition. Complete with instructions and all components (if applicable). Certain items may not be eligible for return (e.g. custom fabricated and /or special ordered items, labor charges, etc). Provide a copy of the original order showing the purchase information and date of purchase. Also provide a brief explanation for the return. An administration, restocking charge may be applicable to all merchandise returned to cover costs involved in processing the return. Please call first for return authorization and instructions.

For further information on our products, contact us via e-mail at mail@g3ignition.com

**Generation 3 Ignition
2331 W. Hampden Ave. Suite 130
Englewood. CO. 80110
Phone: (303) 806-5120**