

Installation Instructions



Single-Phase PV Systems

Solahart PV Systems must be installed and serviced by a suitably qualified person.

⚠ Warning: For continued safety of this PV System, it must be installed, operated and maintained in accordance with these instructions and the installation guide supplied with the PV inverter.

⚠ Caution: Only qualified and accredited personnel should perform work on PV systems, such as design, installation, commissioning, maintenance and repairs. Be sure to follow the safety instructions for all system components. It is also important to observe relevant local codes and regulations for health and safety and accident prevention.

Only Solahart parts and Solahart approved parts may be used. No substitute parts may be used without prior approval from Solahart Industries Pty Ltd. Only parts supplied by Solahart Industries Pty Ltd are covered by the Solahart warranty.

The warranty can become void if safety devices are tampered with or if the installation is not in accordance with these instructions.

PATENTS

This PV System may be protected by one or more patents or registered designs in the name of Solahart Industries Pty Ltd.

TRADE MARKS

TM Trademark of Solahart Industries Pty Ltd.

Note: Every care has been taken to ensure accuracy in preparation of this publication. No liability can be accepted for any consequences, which may arise as a result of its application.

CONTENTS

Contents	3
Overview.....	4
Wiring Diagrams	6
Earthing Arrangements – All Systems	9
Installation Procedure.....	10
Planning	11
Racking.....	15
Rooftop Isolator	22
Wiring	23
Power Optimizers (SolarEdge only)	25
PV Modules	28
Inverter	33
Meter (SolarEdge Only).....	37
Labelling	40
Commissioning.....	42
Engineering Certification.....	49
Solahart PV System Warranty - Australia Only	51

OVERVIEW

The following installation instructions detail installation procedures for photovoltaic modules, power optimizers, inverter, module racking systems and balance of system (BOS) components.

Prior to the installation of any grid connected PV system, a Site Visit shall be performed in accordance with the Clean Energy Council's "Grid-Connected Solar PV Systems - Design Guidelines for Accredited Installers".

SAFETY REQUIREMENTS

The voltages and currents produced by a single module or modules connected in series (voltages added together) or in parallel (currents added together) can be dangerous.

Although module DC plug connectors are insulated to provide touch safe protection, the following points must be observed when handling modules in order to avoid the risk of sparking, fire hazard, burn risk, and lethal electric shocks:

- Exercise extreme caution when wiring modules and look out for damaged or split cable ends.
- Do not perform wiring work in rainy or damp conditions.
- Never insert metallic or otherwise conductive objects into plugs or sockets.
- Ensure that all electrical connections are completely dry and free from contaminants before they are assembled.
- Ensure that connections are tight and correctly made.
- Keep all materials, tools and work areas clean and dry.
- Always use appropriate safety equipment such as insulated tools and wear personal protective equipment such as insulated gloves.
- Solar modules produce current when exposed to sunlight. It is recommended that the system is shielded with an opaque cover during installation, maintenance or repair work.

INSTALLER RESPONSIBILITIES

The installer is solely responsible for:

- Observing and conforming to all relevant Australian Standards, all relevant Clean Energy Council Accreditation guidelines and all applicable laws, ordinances, regulations, codes of practice and local or national building codes, including any that may have superseded these Installation Instructions.
- Ensuring that the installation complies with AS/NZS 3000, AS/NZS 5033, AS/NZS 1170.2, AS/NZS 1562.1, AS 4777.1, AS/NZS 1768, AS/NZS 3008, AS 2050 and any relevant electrical service and installation rules for the state or territory where the system is installed.
- Ensuring that the PV System and associated components are appropriate for the particular installation and the installation environment.
- Ensuring that the roof, roof rafters, battens, purlins, connections, and other structural support members can support the total assembly under building live load conditions. The roof on which the PV system is to be installed must have the capacity to resist the combined Design Dead Load and Live Load at each mounting point.
- Ensuring only parts supplied by Solahart Industries and installer supplied parts as specified by Solahart Industries are utilised (substitution of parts may void the warranty and invalidate certification).
- Ensuring that lag screws have adequate pull-out strength and shear capacities to suit the installation.
- Maintaining the waterproof integrity of the roof, including selection of appropriate flashing.
- Ensuring safe installation of all electrical aspects of the PV system.

DISCLAIMER OF LIABILITY AND WARRANTY

Solahart assumes no responsibility for loss, damage or expense resulting from improper installation, handling or misuse of PV modules. Refer to “Solahart PV System Warranty - Australia Only” on page 51 for full warranty terms and conditions.

IEC 61730 INFORMATION

Modules supplied by Solahart are designed to fulfil the criteria of application Class A requirements according to IEC 61730. Modules are qualified for application Class A: Hazardous voltage (Higher than 50 V DC) and hazardous power (higher than 240 W) applications where general contact access is anticipated. For the purposes of AS/NZS 3000, modules are classified as Class I equipment.

FIRE GUIDELINES

Utilise the following fire safety guidelines when installing modules supplied by Solahart:

- Modules supplied by Solahart have a Class C Fire Rating.
- Check with local authorities for guidelines and requirements concerning fire safety for any building or structure on to which the modules will be installed.
- The system design should ensure that fire fighting personnel can access the system in the event of a building fire. Check with local authorities for any applicable regulations concerning setbacks or other placement restrictions that may apply for roof-mounted PV arrays.
- Any electrical equipment can pose a fire risk. Modules must therefore be mounted over a fire retardant roof covering rated for the application.

ENVIRONMENTAL FACTORS

Solahart's limited warranty is based upon modules being installed in accordance with the following conditions:

- Modules are not suitable for installation in potentially hazardous locations.
- Modules should not be installed in locations:
 - close to fire or combustible materials.
 - where there is potential for extreme sand and dust damage.
 - in direct contact with salt water/spray. Avoid installing in areas subject to high salt mist content e.g. coastal areas.
 - exposed to extreme air pollution, chemical vapours, acid rain and/or soot, etc.
 - which experience extreme hail and/or snow.
 - where they may be exposed to sulphur e.g. near sulphur springs or volcanoes where they may be exposed to harmful chemicals.

WARNINGS

⚠Warning: This document provides sufficient information for system installation heights up to 10 m. If the installation site is more than 10 m in height contact Solahart Industries for further advice.

⚠Warning: This system has not been certified for, and should not be installed in, wind region D.

⚠Warning: During installation and when working on the roof, be sure to observe the appropriate OH&S safety regulations and relevant regulations of your local region.

⚠Warning: Ensure electrical connection/ disconnection is performed only when the relevant circuit is isolated. Do not connect / disconnect wiring under load conditions.

⚠Warning: Do not expose the PV modules to artificially concentrated light.

⚠Warning: Do not drill holes in the modules as this will void product warranty.

WIRING DIAGRAMS

SINGLE INPUT INVERTER SYSTEMS

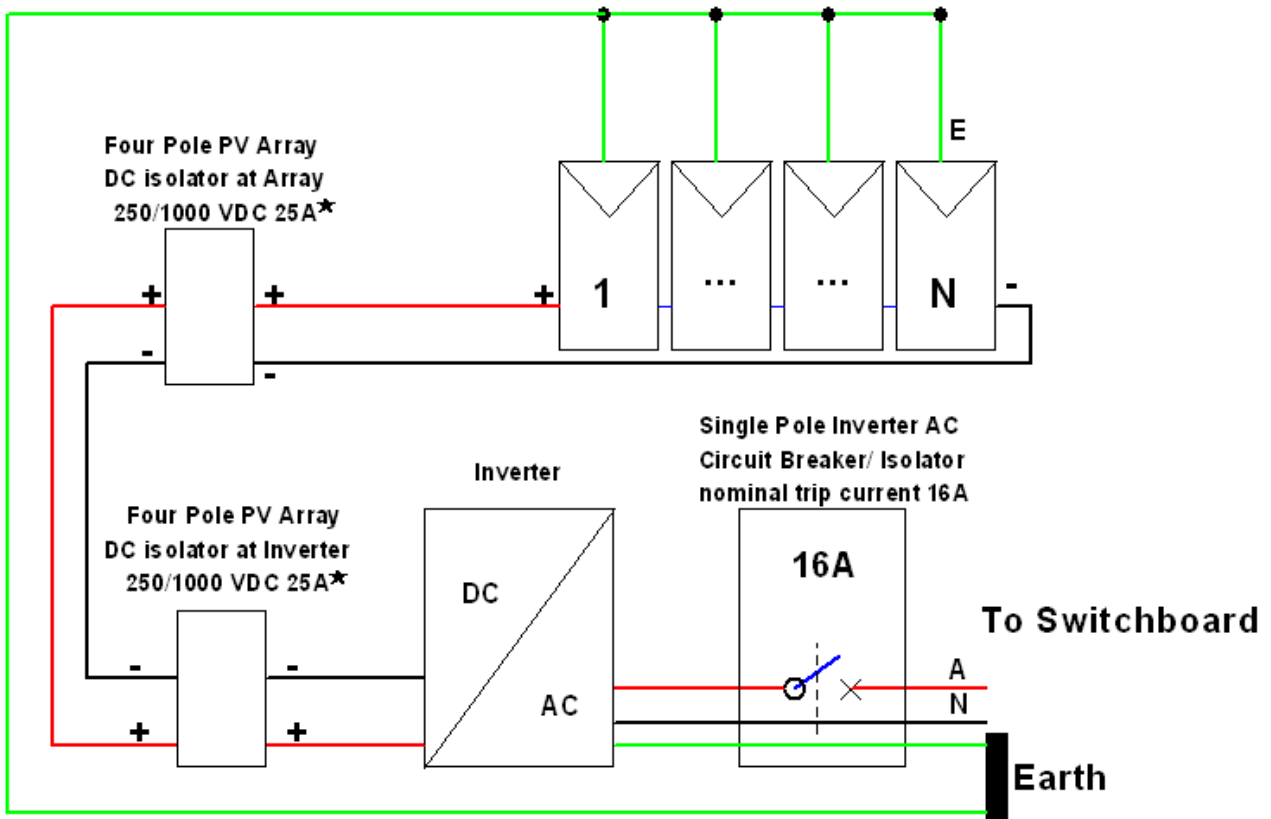

★For DC Isolator Wiring refer to “DC Isolator Wiring” on page 24.

Inverter	Min No of Modules	Max No of Modules	Max No of Strings	Max No of Modules per Inverter	REC280TP Modules		
					Max System Power Rating (W) *	I _{sc} (A)* per String	V _{oc} (V)*
SB1.5-1VL-40	4	7	1	7	1960	9.4	Check Voltage Tables on page 8
SB2.5-1VL-40	4	11	1	11	3080	9.4	

* Values measured at standard test conditions (STC) defined as: irradiance of 1000 W/m², Spectrum AM 1.5 and cell temperature 25°C. Variations from STC values will affect actual I_{sc} and V_{oc} and should be allowed for.

For earthing arrangement and wiring diagram refer to “Earthing Arrangements – All Systems” on page 9.

MULTIPLE INPUT INVERTER SYSTEMS

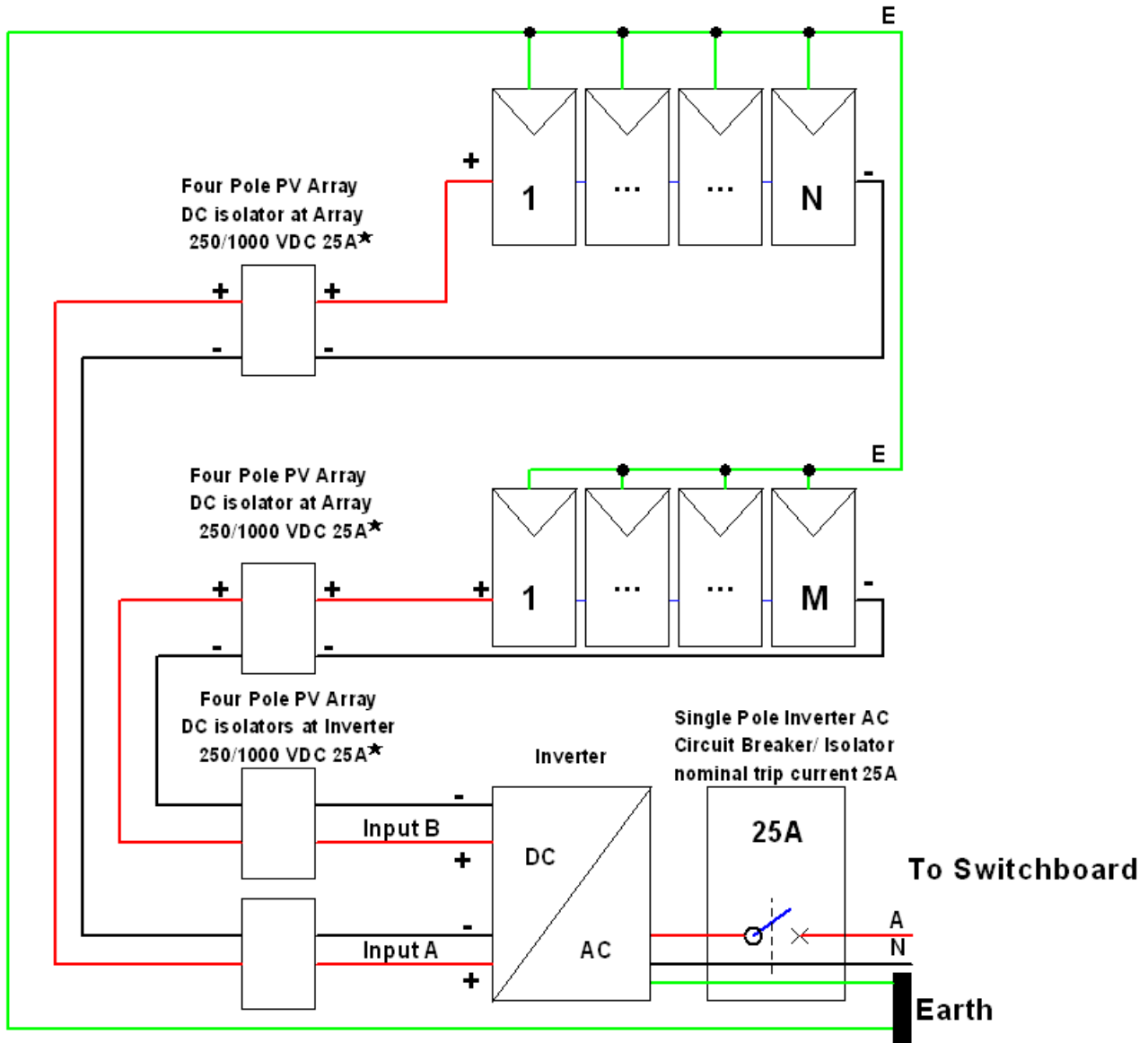

*For DC Isolator Wiring refer to “DC Isolator Wiring” on page 24.

Inverter	Min No of Modules	Max No of Modules per String	Max No of Strings	Max No of Modules per Inverter	REC280TP Modules		
					Max System Power Rating (W) *	I _{sc} (A)* per String	V _{oc} (V)*
SB3000TL-21	6	13	2	14	3920	9.4	Check Voltage Tables on page 8
SB4000TL-21	6	13	2	19	5320	9.4	
SB5000TL-21	6	13	2	21	5880	9.4	
SB3.0-1AV-40	4	13	2	14	3920	9.4	
SB4.0-1AV-40	4	13	2	19	5320	9.4	
SB5.0-1AV-40	4	13	2	23	6440	9.4	
PVI-3.0-TL-OUTD	5	13	2	14	3920	9.4	
PVI-4.2-TL-OUTD	5	13	2	20	5600	9.4	
PVI-5000-TL-OUTD	5	13	2	21	5880	9.4	

* Values measured at standard test conditions (STC) defined as: irradiance of 1000 W/m², Spectrum AM 1.5 and cell temperature 25°C. Variations from STC values will affect actual I_{sc} and V_{oc} and should be allowed for.

For earthing arrangement and wiring diagram refer to “Earthing Arrangements – All Systems” on page 9.

SE5000 INVERTER SYSTEMS

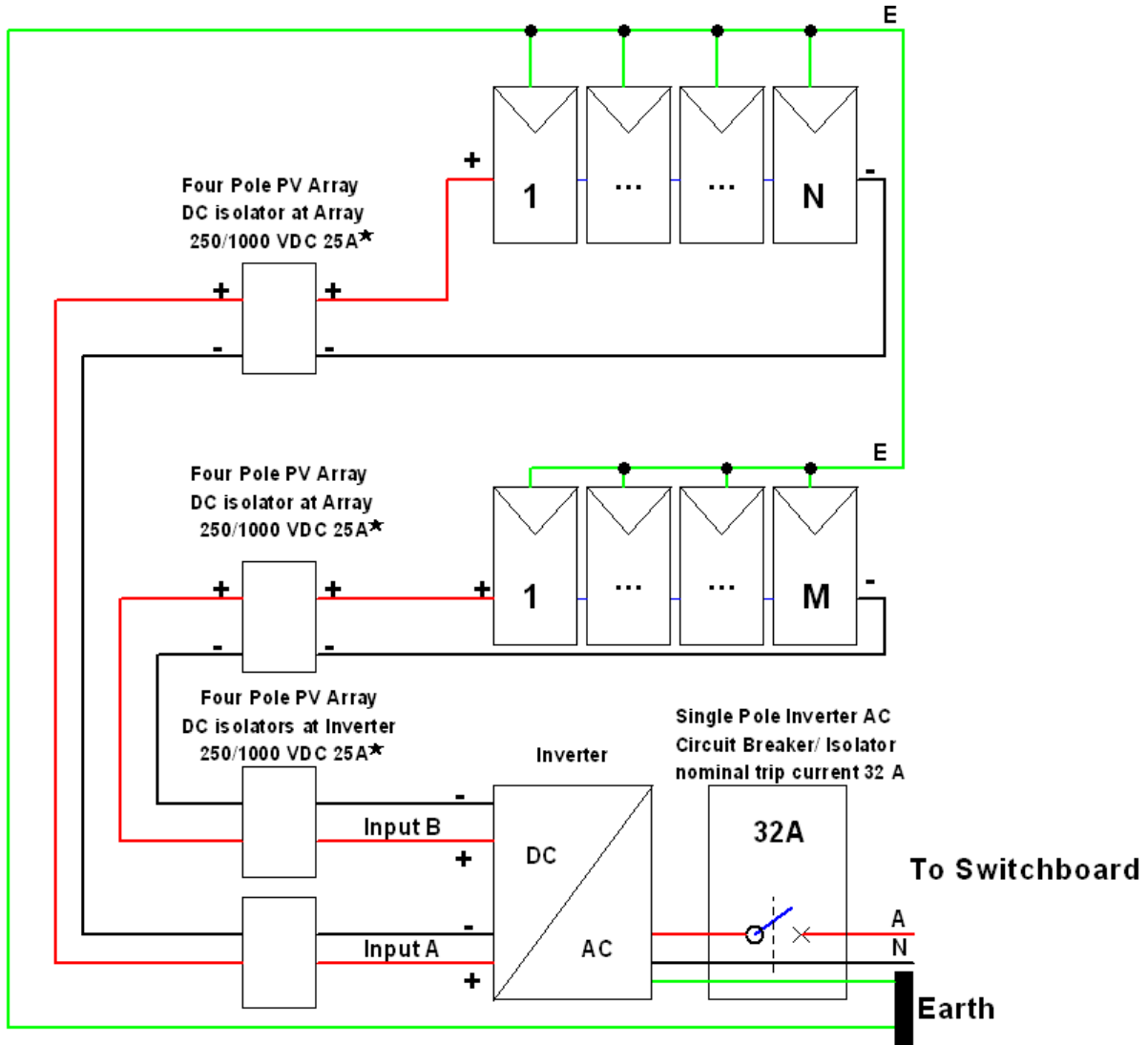

★For DC Isolator Wiring refer to “DC Isolator Wiring” on page 24.

Inverter	Min No of Modules	Max No of Modules per String	Max No of Strings	Max No of Modules per Inverter	REC280TP Modules		
					Max System Power Rating (W) *	Max Inverter Current (A)*	Max Inverter Voltage (V)*
SE5000 Models**	8	18	2	23	6440	19.5	500

* Values measured at standard test conditions (STC) defined as: irradiance of 1000 W/m², Spectrum AM 1.5 and cell temperature 25°C. Variations from STC values will affect actual I_{sc} and V_{oc} and should be allowed for.

** This model may have suffixes indicating different options and functionality.

For earthing arrangement and wiring diagram refer to “Earthing Arrangements – All Systems” on page 9.

VOLTAGE TABLES

V_{oc} of REC280TP = 39.2V

No of Modules per String	V _{oc} of the String	No of Modules per String	V _{oc} of the String
4	156.8	9	352.8
5	196	10	392
6	235.2	11	431.2
7	274.4	12	470.4
8	313.6	13	509.6

EARTHING ARRANGEMENTS – ALL SYSTEMS

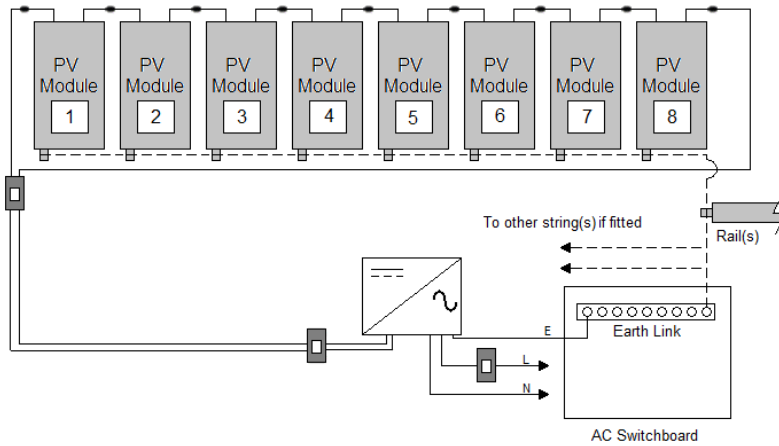

Module & Rail
Earth Connection Method

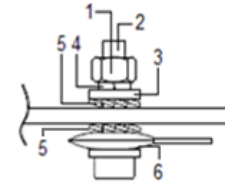

- 1 Stainless steel M4 nut
- 2 Stainless steel M4 X 30mm bolt
- 3 Stainless steel M4 flat washer
- 4 Stainless steel M4 spring washer
- 5 Stainless steel M4 serrated washer
- 6 Stainless steel M4 slotted washer or lug

Earthing connections must be made so the removal of one component (e.g. a module) does not interrupt the earthing to other parts of a system (e.g. other modules). Daisy chaining is not permitted. The PV system earth connection must be directly connected to the switchboard earth link, not via the inverter earth connection. If the earth cable could be exposed to direct sunlight, it must have a physical barrier to protect the earth cable from this exposure.

Earth wires must be sized in accordance with requirements set out in Earthing and bonding arrangements of AS/NZS 5033.

Solahart approved earthing plates may be used to earth modules via the racking, instead of wiring directly to the module frames. Refer to “Earthing” on page 29 for more information.

⚠ Warning: Do not drill holes in the modules as this will void product warranty.

The racking may be earthed by means of a rooftop isolator bracket. Refer to “Rooftop Isolator” on page 22 for details.

Where it is necessary to make an earthing connection to a rail that does not have a rooftop isolator bracket fitted, a rail splice piece will provide a suitable surface for connection. In this case, the splice should be attached to the end of the rail using both fixing bolts, and then the earth lug connected to the splice as shown in the figures below:

1. Slide rail splice onto end of rail, ensuring an overhang of approximately 50 mm.
2. Secure rail splice by tightening both Allen head bolts to 15 Nm.
3. Drill a hole in the centre of the rail splice, attach the earth cable using the earthing set supplied, and tighten to 5 Nm.



Rail splice attached to rail with both Allen head bolts



Earth cable connected to splice

INSTALLATION PROCEDURE

1. Planning – Design the system and layout. Refer to “Planning” on page 11.
2. Determine the spacing of the Rail Supports using the “Maximum Rail Support Spacing Tables” on page 16 and considering the following factors (refer to “Planning” on page 11):
 - a. Wind Region
 - b. Terrain Category
 - c. Roof Type
 - d. Roof Area
 - e. Building Height
 - f. Array Orientation
3. Install the Racking (Rail and Rail Supports). Refer to “Racking” on page 15.
4. Install the remainder of the roof top components as follows:
 - a. Rooftop Isolator. Refer to “Rooftop Isolator” on page 22.
 - b. Rooftop Wiring. Refer to “Wiring” on page 23.
 - c. Power Optimizers. Refer to “Power Optimizers (SolarEdge only)” on page 25
 - d. PV modules. Refer to “PV Modules” on page 28.
5. Install the inverter. Refer to “Inverter” on page 33.
6. Install the energy meter (optional component). Refer to “Meter (SolarEdge Only)” on page 37.
7. Install the system labels. Refer to “Labelling” on page 40.
8. Commission the PV system. Refer to “Commissioning” on page 42.

PLANNING

INSTALLATION TOOLS

- 4,5 & 6 mm Allen keys or 4,5 & 6 mm Allen Key fittings to suit torque adjustable drill (for racking components and inverter)
- Torx T20 screwdriver (Power-One/ABB inverter systems only)
- Cordless torque adjustable drill
- Angle grinder with stone disk (for tile cutting if required)
- Electricians hand tools (screwdrivers, pliers etc.)
- String line
- Timber to shim tile roof interfaces (if required)

STRUCTURAL ASSESSMENT

The installer is responsible for ensuring that the building and building structures are capable of withstanding the additional loads and forces generated as a result of installing the PV system. For domestic dwellings, it is recommended that a structural engineering assessment is completed. For all other installations, a structural assessment is required to be completed by a qualified structural engineer.

COMMUNICATIONS DEVICES

Complete installation of inverter communications devices requires the installer to register the communication device and inverter on the inverter manufacturer's web portal. Hence, to complete the communications equipment installation, the installer must have access to the PV system owner's internet connection. An example of items that should be organised prior to onsite installation are:

- Confirmation that an internet accessible network port is available
- Length of networking cable required from inverter to networking port
- Wi-Fi access including SSID and password
- PV system owner's network administrator permission and assistance to adjust firewall, network address translation (NAT) and port forwarding settings.

PV MODULE ORIENTATION AND INCLINATION

To maximize system output, install modules at optimum orientation and inclination (tilt) angles. The specifics of this will depend on the installation location and must be calculated by a qualified system designer. The ideal angle for mounting a module should result in the sun's rays falling perpendicular (i.e. at a 90° angle) to the module surface.

Note: All modules in each series string must have the same orientation and inclination to ensure that modules do not underperform due to a mismatching of each module's output.

Modules should be installed in a shade free position. Even minor or partial shading of the modules/array will reduce array/system output. A module is considered shade free when it is both:

- Free from shade or shadows all year round.
- Exposed to several hours of direct sunlight, even during the shortest days of the year.

Note: The following information is provided as a guide only:

- Modules should be installed facing toward true north. Where this orientation is not practical, a system facing up to 45° (NW or NE) from true north is satisfactory however losses of up to approximately 6% will occur. A module facing due east or due west will experience a loss in performance of approximately 18%.
- Inclination of modules should be approximately equal to the local latitude angle. The latitude of some Australian cities is shown in the "Latitude of Some Australian Cities" on page 12. Modules may be

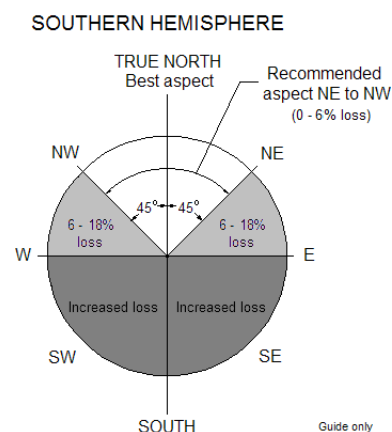

installed at the roof angle for simplicity of installation and appearance, however, if inclination varies by $\pm 15^\circ$ or more from the correct inclination, performance losses of 4% or more will occur.

- Modules should be inclined at an angle of at least 10° to support the self cleaning function of the glass.
- Losses for incorrect orientation and incorrect inclination will be compounded.
- If the roof angle is flat, adjustable or fixed tilt legs should be considered to optimise inclination depending upon area.
- For an installation at right angles to (across) a tile roof pitch, landscape tile roof hooks are required.
- Each module and its fittings including racking weighs approximately 25 kg.

LATITUDE OF SOME AUSTRALIAN CITIES

Adelaide	35°S	Cairns	17°S	Hobart	42°S	Port Hedland	20°S
Alice Springs	24°S	Canberra	35°S	Mildura	34°S	Rockhampton	24°S
Brisbane	27°S	Darwin	12°S	Melbourne	38°S	Sydney	34°S
Broken Hill	31°S	Geraldton	28°S	Perth	32°S	Townsville	19°S

WIND REGION

Use the wind region diagram shown below to determine the wind region of the installation site.

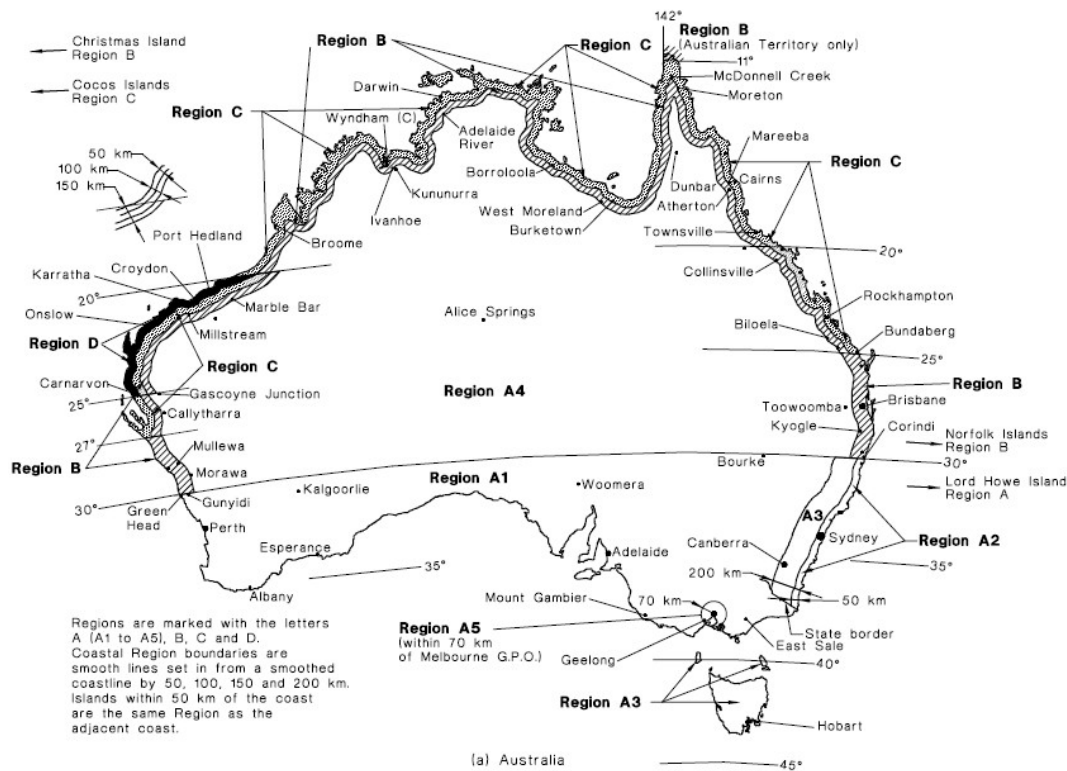

Wind region notes:

- Wind regions are predefined for all of Australia by Australian Standard AS/NZS 1170.2. The Wind Region has nothing to do with surrounding topography or buildings.
- Most of Australia is designated Region A which indicates a Regional Ultimate Basic Wind Velocity of 45 m/s.
- Some areas are designated Region B (57 m/s). Local authorities will advise if this applies in your area.
- Region C areas (66 m/s) are generally referred to as Cyclonic and are generally limited to northern coastal areas. Most Region C zones end 100 km inland.
- Region D (80 m/s) Australia's worst Cyclonic Region between Carnarvon and Pardoo in WA.

TERRAIN CATEGORY

The terrain over which the approaching wind flows towards a structure must be assessed on the basis of the following category descriptions:

Terrain Category 2: Open terrain, including grassland, with well-scattered obstructions having heights generally from 1.5 m to 5 m, with no more than two obstructions per hectare, e.g. farmland and cleared subdivisions with isolated trees and uncut grass.

Terrain Category 3: Terrain with numerous closely spaced obstructions having heights generally from 3 m to 10 m. The minimum density of obstructions shall be at least the equivalent of 10 house-size obstructions per hectare, e.g. suburban housing or light industrial estates.

ROOF TYPE

Determine the roof type of the building where the PV modules are to be installed and select the appropriate rail support.

Rail support systems are available as follows:

Roof Type	Roof Pitch	Rail Support Category	Rail Support Name (Options)
Standard tile	10 - 30°	Tile roof interface	Tile interface (Portrait)
Low profile tile			Tile interface (Landscape)
Slate			Flat tile interface
Metal	10 - 30°	Metal roof interface	Metal roof interface
Metal Corrugated	< 10° or < Latitude minus 15°	Tilt leg interface	10 - 15° adjustable tilt legs
			15 - 30° adjustable tilt legs
			30° fixed tilt legs
			30 - 60° adjustable tilt legs



ROOF AREA

Determine the installation area on the roof (roof position area). The diagrams below show roof position areas designated as “Edge Zone” areas and “Centre Zone” areas according to interface type.

Edge zone areas are subject to higher wind loadings and therefore will require closer rail support spacing.

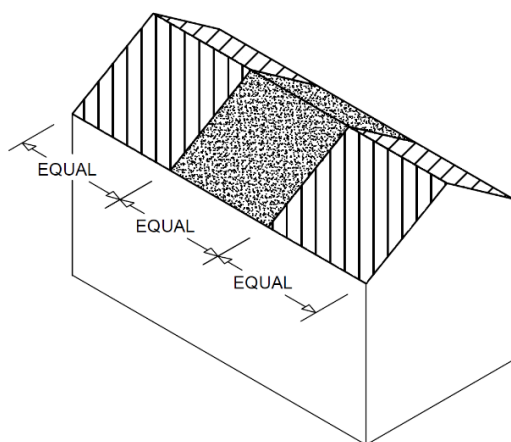
⚠ Warning: If any part of the system array is located in one of the edge zones, the entire array must use the support spacing specified for the edge zones.



 CENTRE ZONE  EDGE ZONE

Tile & Metal Roof Interface - Roof Area Definition

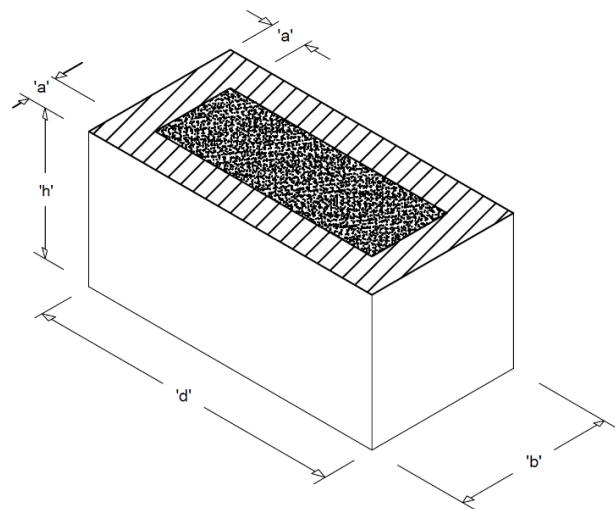

a = MINIMUM OF 0.2b, 0.2d AND h

Tilt Leg Interface - Roof Area Definition

Use the following diagram, tables and worked example to determine the minimum required roof area for the array when designing and installing with REC280TP modules.

REC280TP spacing and dimensions

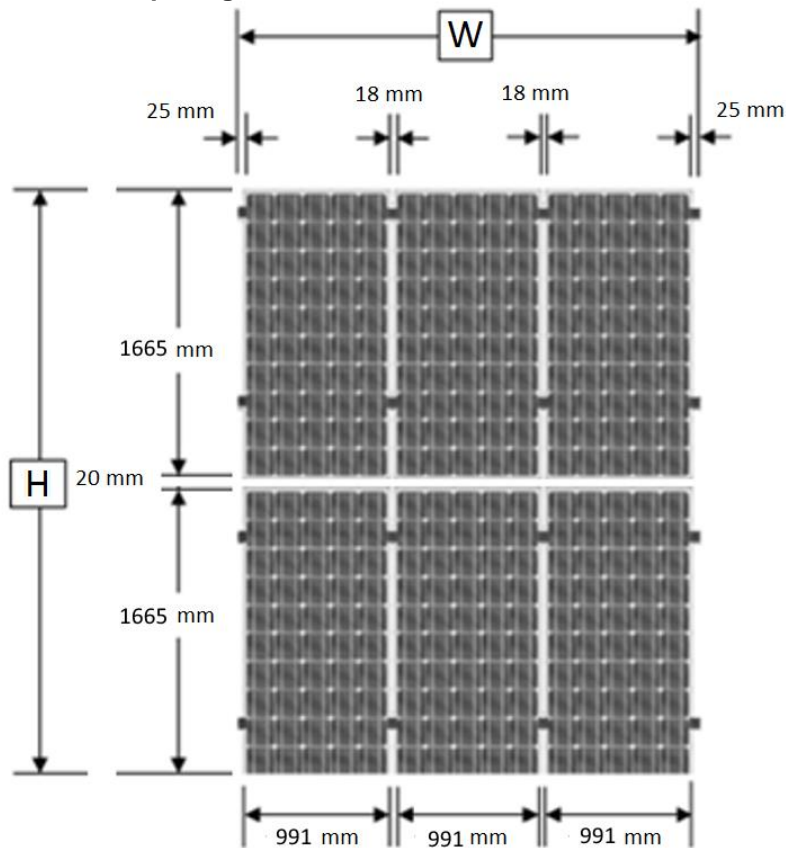

H = Number of rows X (1665mm + 20 mm) - 20 mm

W = Number of modules per row X (991 mm + 18 mm) + (2 X 25 mm) - 18 mm

Worked Example:

Number of rows: 2
 Number of modules per row: 10
 Total number of modules = 20

Calculating H:
 $H = N_{\text{rows}} \times (1,665 + 20) - 20$
 $H = 2 \times 1,685 - 20$
 $H = 3,350 \text{ mm}$

Calculating W:
 $W =$
 $N_{\text{modules/row}} \times (991 + 18) + (2 \times 25) - 18$
 $W = 10 \times 1,009 + 50 - 18$
 $W = 10,122 \text{ mm}$

Calculating Area_{Roof} in mm²:
 $\text{Area}_{\text{Roof}} = H \times W$
 $\text{Area}_{\text{Roof}} = 3,350 \times 10,122$
 $\text{Area}_{\text{Roof}} = 33,908,700 \text{ mm}^2$
 Converting Area_{Roof} in mm² to m²:
 $\text{Area}_{\text{Roof}} = \frac{33,908,700}{1,000,000} = 33.91 \text{ m}^2$

Calculating Area_{Roof} in m²:
 $\text{Area}_{\text{Roof}} = \frac{H}{1,000} \times \frac{W}{1,000}$
 $\text{Area}_{\text{Roof}} = \frac{3,350}{1,000} \times \frac{10,122}{1,000}$
 $\text{Area}_{\text{Roof}} = 3.35 \times 10.122$
 $\text{Area}_{\text{Roof}} = 33.91 \text{ m}^2$

Notes:





- Modules installed in portrait as per diagram
- For tilt leg systems, row spacing must prevent shading of one row by another and needs to be calculated on an individual site basis, taking into account orientation, roof pitch and module inclination
- All dimensions are in mm, unless otherwise stated.





			Number of modules per row – REC280TP											
			1	2	3	4	5	6	7	8	9	10	...	
Number of rows	1	H	1665	1665	1665	1665	1665	1665	1665	1665	1665	1665	1665	
		X	X	X	X	X	X	X	X	X	X	X	X	
		W	1041	2050	3059	4068	5077	6086	7095	8104	9113	10122		
Number of rows	2	H	3350	3350	3350	3350	3350	3350	3350	3350	3350	3350	3350	
		X	X	X	X	X	X	X	X	X	X	X	X	
		W	1041	2050	3059	4068	5077	6086	7095	8104	9113	10122		
Number of rows	...													

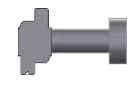



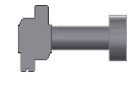

			Number of modules per row – REC280TP										
			1	2	3	4	5	6	7	8	9	10	...
Number of rows	1	Roof Area (m ²)	1.73	3.41	5.09	6.77	8.45	10.13	11.81	13.49	15.17	16.85	
	2	Roof Area (m ²)	3.49	6.87	10.25	13.63	17.01	20.39	23.77	27.15	30.53	33.91	
Number of rows	...												





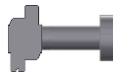

RACKING

OVERVIEW OF RACKING COMPONENTS

Overview of components for tile roof				
				
Rail (a)	Rail splices (c)	Tile roof Interfaces (b)	Z-modules with Allen head bolt	Wood screws M6 x 80

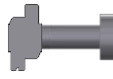
Overview of components for metal roof				
				
Rail (a)	Rail splices (c)	Metal roof interfaces (b)	Z-modules with Allen head bolt	Wood screws M6 x 90 *

Overview of components for adjustable tilt legs					
					
Rail (a)	Rail splices (c)	Z-modules with Allen head bolt	Front rail & leg foot (d)	Adjustable tilt leg (e)	Wood Screws M6x90 *

Overview of components for 30° fixed tilt legs					
					
Rail (a)	Rail splice (c)	Z-modules with Allen head bolts	Front rail & leg foot (d)	Fixed tilt leg (e)	Wood Screws M6x90 *

* **Note:** Screws must be fit for purpose e.g. screws used in metal purlins must be suitable for metal structures and have a TPI (threads per inch) of 14.

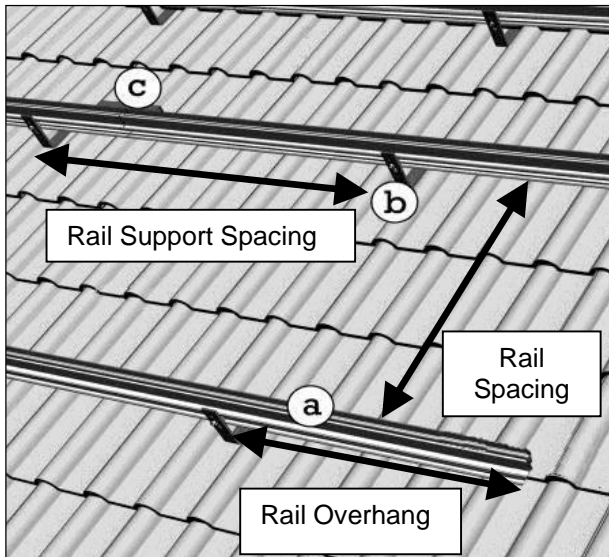

Tile & Metal Roof Diagram (Tile Roof shown)

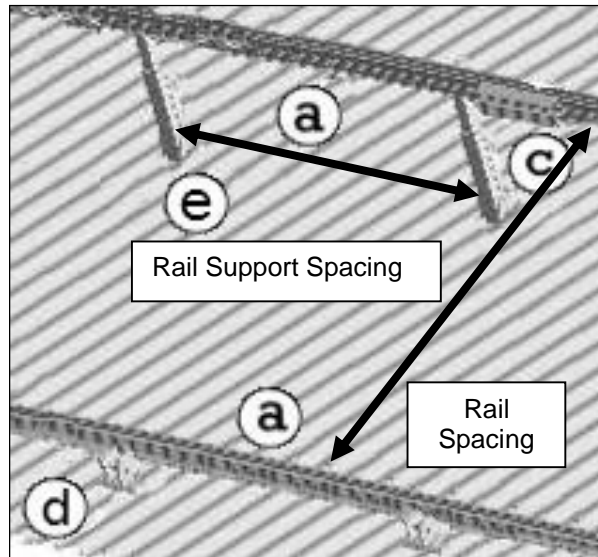

Tilt Leg Diagram (Adjustable Tilt Leg shown)

RAIL SUPPORT SPACING

Use the following tables to determine the rail support spacing for the relevant roof type based on the previously determined wind region, terrain category, roof position area (Edge Zone or Centre Zone) and maximum height of the installation.

MAXIMUM RAIL SUPPORT SPACING TABLES

Wind Region A								
Terrain Category	2				3			
Roof Area	Edge Zone		Centre Zone		Edge Zone		Centre Zone	
Roof Height (m)	5	10	5	10	5	10	5	10
Tile Roof (Timber Rafters only)	1200	950	1575	1275	1475		1800	
Metal Roof with Timber Battens	1505	1247	1700	1600	1675		1800	
Metal Roof with Steel Battens	1075	890	1523	1261	1432		1800	
Tilt Legs – PV Module Angle 15°	1325	1025	1500	1254	1400		1575	
Tilt Legs – PV Module Angle 30°	1089	902	1400	1350	1325		1500	

Wind Region B								
Terrain Category	2				3			
Roof Area	Edge Zone		Centre Zone		Edge Zone		Centre Zone	
Roof Height (m)	5	10	5	10	5	10	5	10
Tile Roof (Timber Rafters only)	825	675	1100	875	1025		1350	
Metal Roof with Timber Battens	938	777	1329	1101	1250		1759	
Metal Roof with Steel Battens	670	555	949	786	893		1265	
Tilt Legs – PV Module Angle 15°	927	768	944	782	1235		1257	
Tilt Legs – PV Module Angle 30°	679	562	1078	892	904		1435	

Wind Region C								
Terrain Category	2				3			
Roof Area	Edge Zone		Centre Zone		Edge Zone		Centre Zone	
Roof Height (m)	5	10	5	10	5	10	5	10
Tile Roof (Timber Rafters only)	525	450	700	575	650		850	
Metal Roof with Timber Battens	582	526	825	745	910	735	1289	1042
Metal Roof with Steel Battens	416	375	589	532	650	525	921	744
Tilt Legs – PV Module Angle 15°	576	520	586	529	850	727	915	740
Tilt Legs – PV Module Angle 30°	421	380	669	604	658	532	1045	845

Roof interfaces must be fixed to rafters or purlins under the roof cladding. Screw minimum embedment into timber rafters is 50 mm and 35 mm for timber battens.

Steel purlins must meet the following minimum requirements:

Roof interface	Minimum steel purlin specification
Metal roof interface	0.55 mm BMT 550 Grade or 0.75 mm BMT 450 Grade
Tilt leg interface	1.0 mm BMT 500 Grade

Note: Screws supplied with the roof interfaces are wood screws suitable for timber only. Screws used in metal purlins must be suitable for metal structures and have a TPI (threads per inch) of 14.

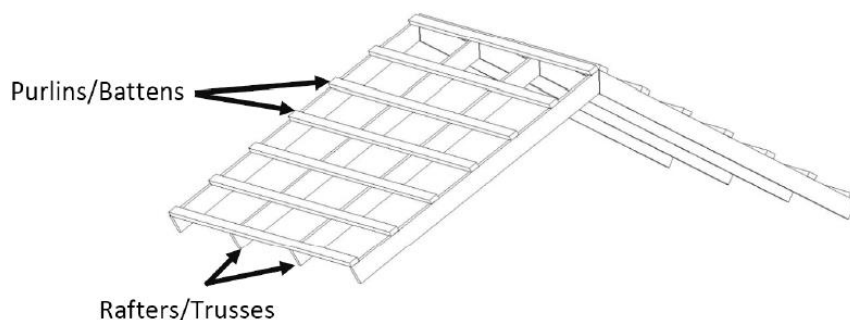

RAIL SPACING

Rails should be spaced so that the module is clamped in the correct positions.

In general, the rails may be spaced between 833 mm and 1249 mm apart.

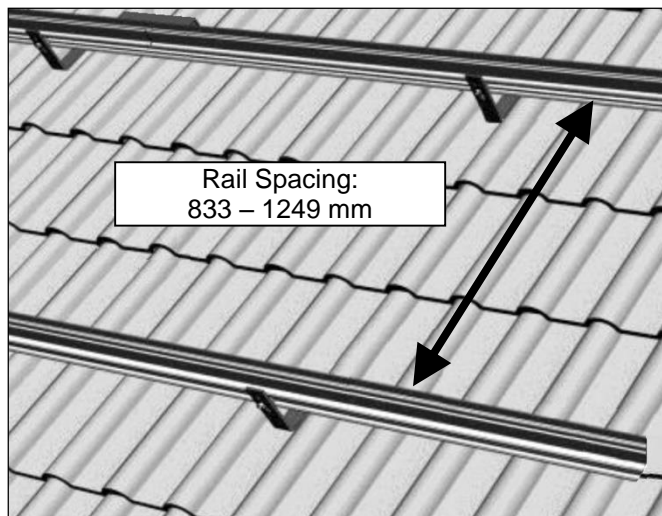
**RAIL OVERHANG**

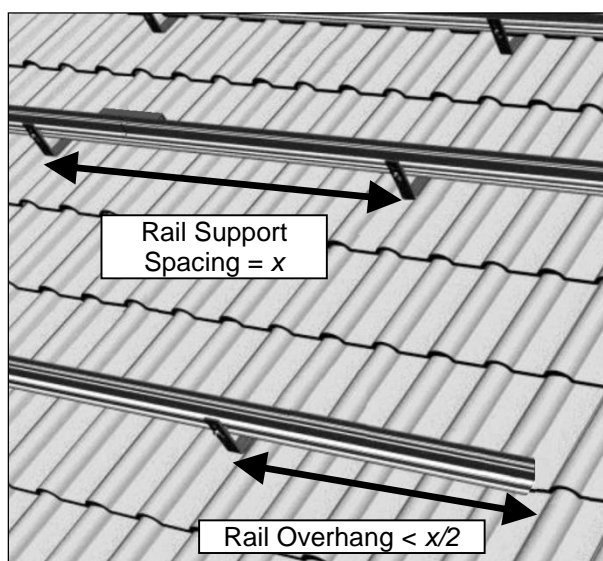

Rail end overhang must be no greater than 50% of rail support spacing. For example; if rail support spacing is 1200 mm, rail end overhang can be up to 600 mm. In this case, two rail support brackets can support a rail up to 2400 mm in length (1200 mm between brackets and 600 mm of overhang at each end).



Note: Drawings not to scale

TILE ROOF INSTALLATION

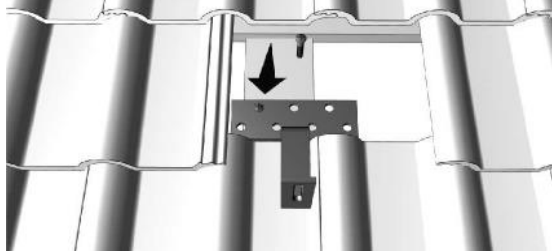
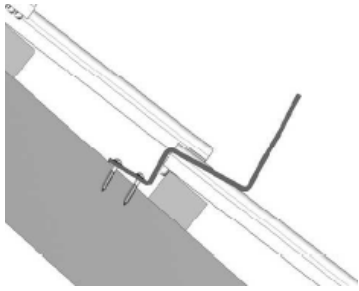
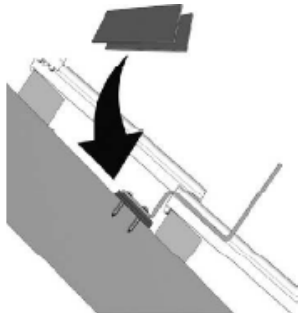
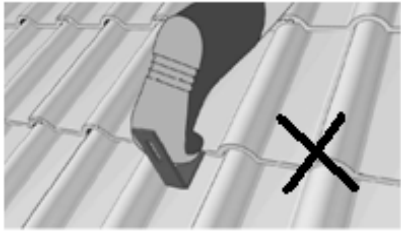
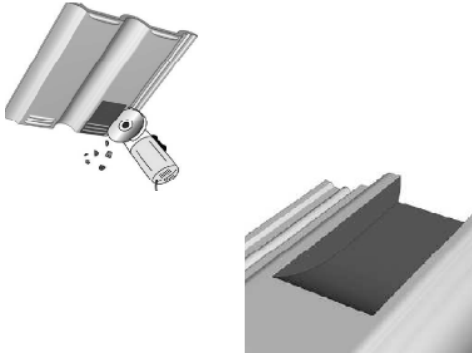
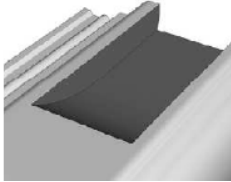
Note: The tile roof interface is only suitable for installation on timber rafters.

<p>1. Determine and mark the position of the tile roof interfaces according to your plans. Remove the roof tiles at marked positions or, if possible, simply move the tiles up slightly.</p>		
<p>2. Fix the tile roof interfaces to rafters using two M6 X 80 mm wood screws. Ensure a 50 mm minimum screw embedment into the rafters.</p>		
<p>3. Warning: Tile roof interfaces must not press against roof tiles and must be fixed parallel with rafters. If necessary, pack underneath tile roof interfaces with timber.</p>	<p style="text-align: center;">Incorrect</p> 	<p style="text-align: center;">Correct</p> 
<p>4. Warning: Do not use tile roof interfaces as a climbing support as extreme loading of this point could cause damage to the tile below.</p>		
<p>5. For thin tiles (such as slate, shingles) proceed directly to step 6.</p> <p>For thick tiles (such as grooved tiles), if necessary, use an angle grinder to chase a recess (or remove raised grooves) on the tile that covers the tile roof interface at the point where the interface protrudes through so that the tile lies flat.</p> <p>For thick tiles it may also be necessary to cut a recess into the tile located below the tile roof interface.</p> <p>Now proceed to installation of the rails. Refer to "Rail Installation" on page 21.</p>	  	

- For thin tiles (such as slate, shingles), a portion of tile must be cut and removed from the tile above the tile roof interface, creating a recess.

Suitable flashing must then be installed around the tile roof interface, with an overlap of at least 150mm at the edges of the recess.

Now proceed to installation of the rails. Refer to "Rail Installation" on page 21.

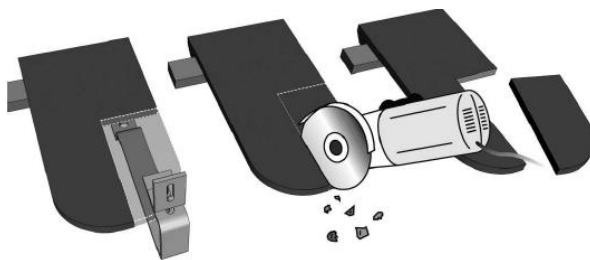

METAL ROOF INSTALLATION

Note: Screws supplied with the roof interfaces are wood screws suitable for timber only. Screws used in metal purlins must be suitable for metal structures and have a TPI (threads per inch) of 14.

- Determine and mark position of the metal roof interfaces according to your plans. Pre drill through roof cladding (on top of crest) at planned locations. Place the supplied rubber gasket under the metal roof interface and ensure that a weatherproof seal is made between the interface and the roof cladding.

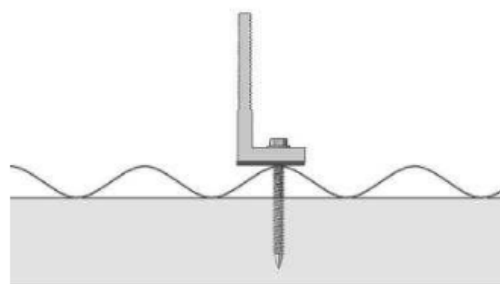

- Fix the metal roof interface to the timber batten or rafter using the M6 x 90 mm screw supplied.

Ensure a 50 mm minimum screw embedment for rafters or 35 mm for timber battens.

If the interface is being fixed to metal purlins use screws suitable for metal structures with a TPI of 14.

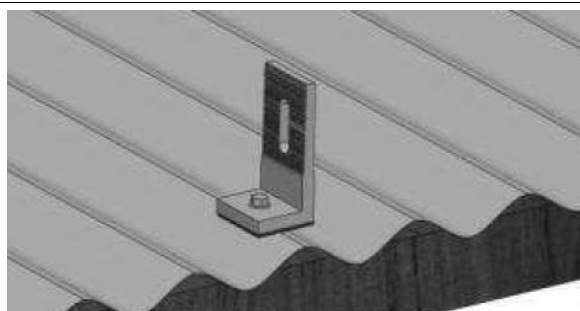

- Check the metal roof interface to ensure that the fastening screw tightly fixes sealing gasket without damaging roof cladding.

Now proceed to installation of the rails. Refer to "Rail Installation" on page 21.

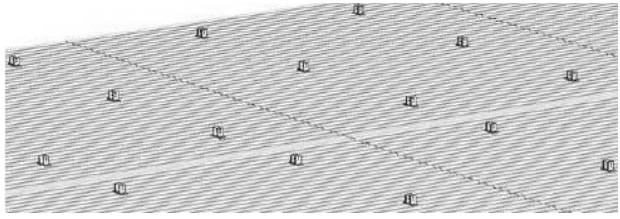
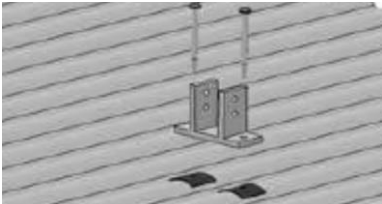

TILT LEG INSTALLATION

Note: Screws supplied with the tilt legs are wood screws suitable for timber only. Screws used in metal purlins must be suitable for metal structures and have a TPI (threads per inch) of 14.

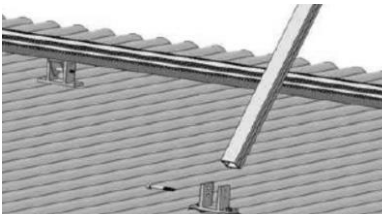
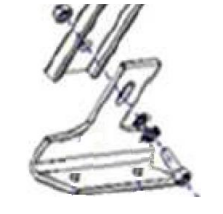
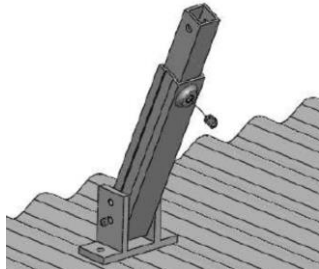
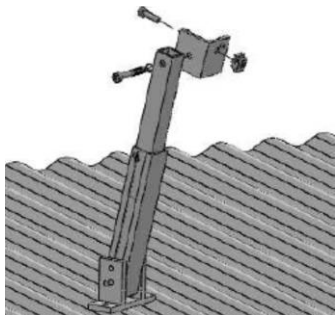
<p>1. Determine and mark position of feet according to your plans. Pre drill through roof cladding (on top of crest) at planned locations. Place the supplied rubber gaskets under each foot and ensure that a weatherproof seal is made between the foot and the roof cladding.</p>	
<p>2. Fix the foot to the timber batten or rafter using a minimum of two M6 X 80 mm screws.</p> <p>Ensure a minimum screw embedment of 35 mm for timber battens and 50 mm for rafters.</p> <p>If the interface is being fixed to metal purlins use screws suitable for metal structures with a TPI of 14.</p> <p>Check the foot to ensure that the fastening screws tightly fix the sealing gaskets without damaging roof cladding.</p>	<div style="display: flex; justify-content: space-around;"> <div style="text-align: center;"> <p>Adjustable tilt leg foot</p>  </div> <div style="text-align: center;"> <p>30° fixed tilt leg foot</p>  </div> </div>
<p>3. Adjustable tilt legs only: Insert feet U brackets into front feet and loosely fasten Allen head bolt and nut to allow for later adjustment. Allen head bolt and Z-module on top of U bracket is utilised to attach rails in next step.</p>	
<p>4. For adjustable tilt legs: Place rear legs into feet, insert Allen head bolt, washer, retaining washer and nut and fasten loosely to allow for later adjustment.</p> <p>For 30° fixed tilt legs: Place rear legs onto feet, insert Allen head bolt, washer, retaining washer and nut and tighten to 15-20 Nm.</p>	<div style="display: flex; justify-content: space-around;"> <div style="text-align: center;"> <p>Adjustable tilt legs</p>  </div> <div style="text-align: center;"> <p>30° fixed tilt legs</p>  </div> </div>
<p>5. Loosen the leg telescopic section Allen head grub screws. Adjust the leg length according to your plans and tighten the grub screws to 17 Nm.</p>	
<p>6. Fix the leg L bracket to the leg using the Allen head bolt, washer, retaining washer and nut and fasten loosely to allow for later adjustment.</p>	

RAIL INSTALLATION

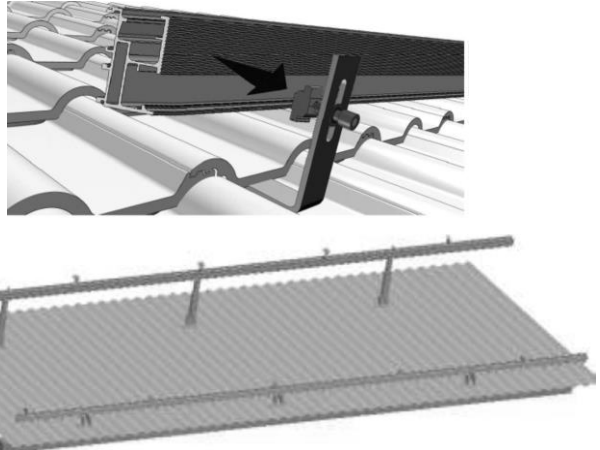
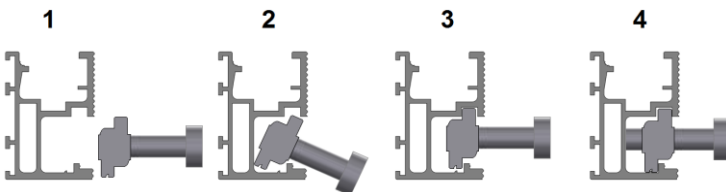
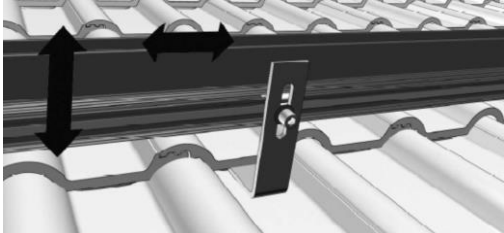
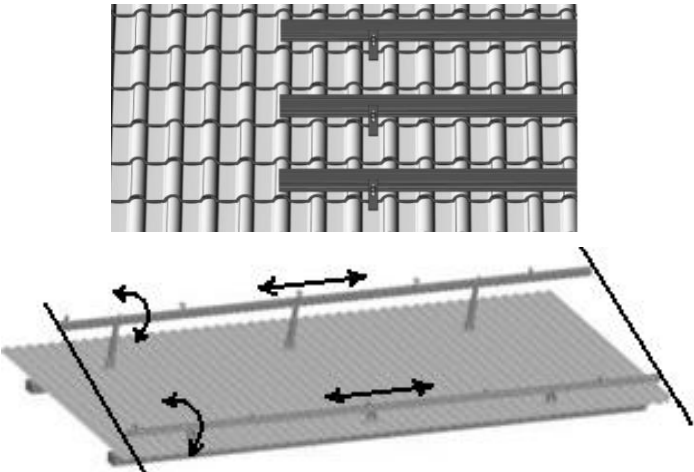
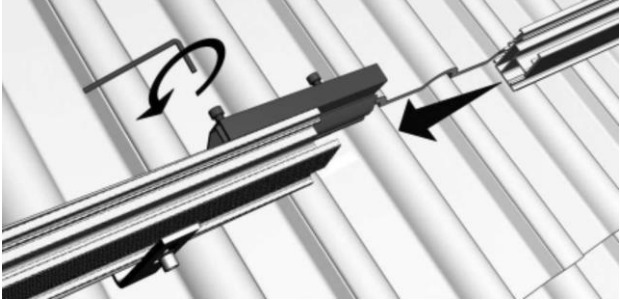
<p>1. Install rails onto the roof interfaces. If the assembly consists of rails of different lengths, always begin with the shortest piece. Install the rail loosely onto the roof interfaces using the Allen head bolt, washer, retaining washer and Z-modules supplied (2 to 3 turns of the bolt are adequate for loose installation). Refer to step 2 for method of inserting Z-module into rail.</p>	
<p>2. For easy use of Z-modules ensure that Allen head bolt threads do not project through lower side of Z-module so that the Z-module is free to move. Position Z-modules in rail channel as shown and fasten loosely with 2 to 3 turns of Z-module Allen head bolt. The rail can then be freely moved along Z-modules.</p>	
<p>3. Adjust the vertical and horizontal position of the rail by taking advantage of the long hole in the tile and metal roof interfaces and the still loose connection of the rail Z-modules.</p>	
<p>4. Align all rail ends.</p> <p>For adjustable tilt legs: align the rail tilt orientation (use a string line if necessary).</p> <p>Tighten all previously loosely installed rail and feet Z-module Allen head bolts to a torque of 21 Nm.</p>	
<p>5. To connect multiple rails together, slide a splice on to the rear side of the previously assembled rail. Tighten the first splice Allen head bolt to 15 Nm. Slide the next rail segment into the splice. An expansion gap at the rail joints is recommended. Leave a gap of approximately 10 mm between the rail joints and then tighten the second Allen head bolt to 15 Nm.</p>	

ROOFTOP ISOLATOR

When installing the rooftop DC isolator, a Solahart Rooftop Isolator Subassembly must be used and must be mounted to the rail by following the steps below. To help prevent UV degradation, the Rooftop Isolator Subassembly should be mounted as far from the north side of the array as possible.

When installing the rooftop isolator the following points should be observed:

- Ensure the IP rating of the isolator enclosure is maintained and that no moisture can enter. The conduit entry points must be on the lower end of the enclosure (i.e.: facing downwards) so that any water will run away from and not towards enclosure entry points. Screw cover caps must be installed and all mounting holes should be sealed with silicone to help prevent water ingress.
- Cable glands and conduit adapters must be chosen to suit the type of cable or conduit used. E.g. cable glands designed for figure-8 cables must be chosen where figure-8 type solar DC cables are utilised.
- Any conduit adapters should be installed so that the conduit slopes downwards from the enclosure to prevent water ingress in adverse weather conditions.
- If water and/or condensation can form in the isolator enclosure, provision must be made for its harmless escape through suitably located drainage points in accordance with AS/NZS 3000 Clause 3.3.2.3. Conduit entering the isolator enclosure must have a drainage hole installed at the lowest point to facilitate the escape of any moisture.

Note: Install Rooftop Isolator Subassembly before installing any PV modules.

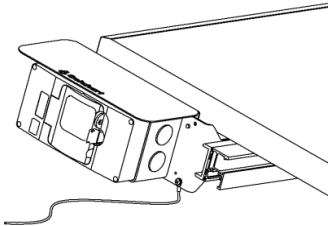
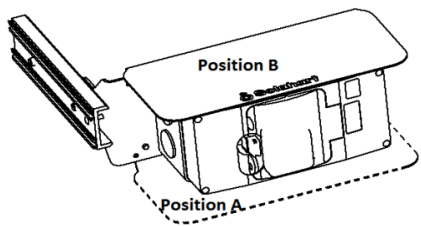
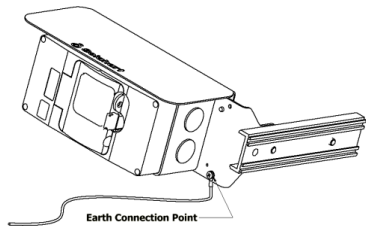
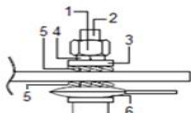
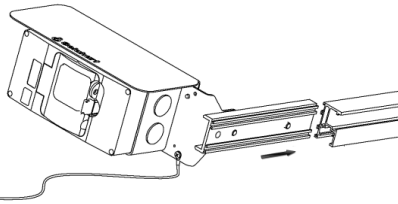
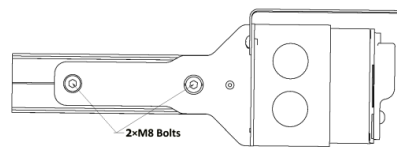
 <ol style="list-style-type: none"> 1. Determine where the Rooftop Isolator Subassembly is to be attached. <ol style="list-style-type: none"> a. The Rooftop Isolator Subassembly is configured for installation on the array as shown above. 	 <ol style="list-style-type: none"> b. If the Subassembly is to be fitted in the other orientation, move the cover (with the Solahart logo) from position A to position B as shown above. c. If in doubt, slide the subassembly into the rail at the point of attachment (see Step 4) and check whether the Solahart logo is facing up.
 <ol style="list-style-type: none"> 2. Identify the earth connection point on the bracket, as shown above. 	 <ol style="list-style-type: none"> 3. Connect the earthing wire to the connection point, as shown above, using a tightening torque of 5 Nm. <p>1 Stainless steel M4 nut 2 Stainless steel M4 X 30mm bolt 3 Stainless steel M4 flat washer 4 Stainless steel M4 spring washer 5 Stainless steel M4 serrated washer 6 Stainless steel M4 slotted washer or lug</p>
 <ol style="list-style-type: none"> 4. Slide the subassembly into the rail making sure that the Solahart logo is facing up (see Step 1) 	 <ol style="list-style-type: none"> 5. Tighten both M8 bolts to 15 Nm, ensuring good connection between the bolts and rail.

WIRING

WIRING

Only UV-resistant cables and connectors approved for outside use should be used. PV cable must be marked or labelled in accordance with AS/NZS 5033.

To minimise the risk of indirect lightning strikes, avoid forming closed loops when designing the system. Check to ensure that system wiring is correct before commissioning modules. If the measured open circuit voltage (V_{oc}) and short circuit current (I_{sc}) differ from specifications, a wiring fault may be present.

Recommended cable size for plug connectors is 4 – 6 mm², with an operating temperature range of -40 to +120°C. Plug connectors are polarised and should be firmly connected. All connections should be secure, tight and electrically and mechanically sound. Correct DC polarity should be observed at all times. Plug connectors should never be used to turn the system on or off (i.e. do not connect or disconnect plug connectors under load conditions).

Only use plug connectors supplied with your Solahart PV system, or which are the same type/model and from the same manufacturer as those on the PV module. Ensure that all plug connectors and plug wiring are in good electrical and mechanical condition and are not subjected to mechanical stress.

Ensure that all materials meet system requirements such as maximum voltage, current, moisture and temperature when exposed to sunlight.

Electrical ratings of the PV modules are within 3% of measured values at Standard Test Conditions (STC). Under normal conditions, a photovoltaic module may experience conditions that produce more current and/or voltage than that reported under STC. When designing a system, allow for increased output of a module as a result of conditions different to STC in accordance with the Clean Energy Council's "Grid-Connected Solar PV System - Design Guidelines for Accredited Installers" and AS/NZS 5033.

Ensure cables are fixed to the mounting structure and are not in contact with the roof or rear surface of module(s) by using restraining devices which are sunlight and UV-resistant.

Note: Plastic cable ties are not to be used as primary means of support.

A roof flashing such as a Dektite® must be used where wiring penetrates tile or metal roofing. Flashings must be sealed using an appropriate waterproofing compound such as silicone.



All wiring must be protected from mechanical damage and external wiring must be protected from UV and mechanical damage in such a manner that it will last the life of the system. All conduits shall comply with AS/NZS 2053.1 and if exposed to sunlight must be suitably UV rated and marked with the letter "T". Do not install wiring such that it is subject to permanent tension.

COMPONENT PLUG AND DC CABLE SIZING TABLE

Cabling	Plug	Cable Size	Plug Rating
Module fly leads	Pre crimped on fly leads	4 mm ²	IP67
Module DC extension leads	Supplied in BOS Kit	Min 4 mm ²	IP67
Wiring – Roof isolator to inverter isolator ^(a)	Not required – hard wired	Min 4 mm ²	N/A
Wiring – Inverter isolator to inverter ^(b)	Supplied in BOS Kit for Power-One/ABB and SolarEdge inverters or as supplied with SMA inverters.	Min 4 mm ²	IP67

^(a) = DC cable supplied by installer.

^(b) = DC cable supplied by installer for SMA inverters only.

All cables/wiring are double insulated Solar DC type cable.

It is recommended the maximum voltage drop between the PV array and the inverter is 3%.

DC ISOLATOR WIRING

The DC isolators utilised in Solahart PV Systems are not polarity sensitive (non polarised type) however for uniformity they should be wired as shown in the DC isolator wiring diagram below.

⚠ Warning: DC isolator terminal screws must be tightened by hand only. Do not use power tools.

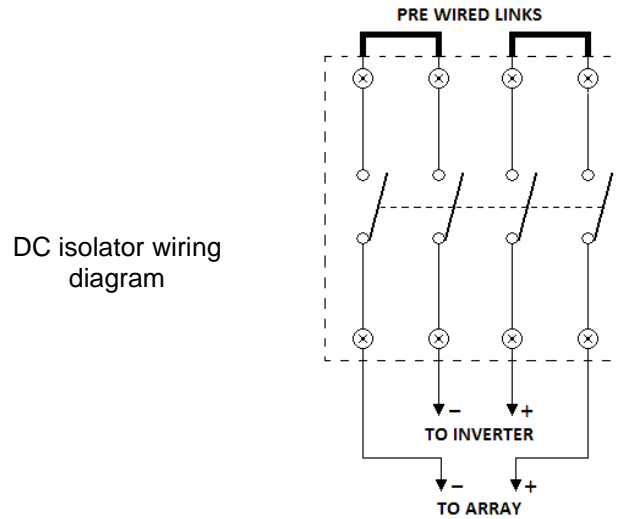

Once wired, the DC isolator should be left in the open position until system commissioning.

POWER OPTIMIZERS (SOLAREEDGE ONLY)

⚠ Warning: Input and output connectors are not watertight until mated. Open connectors should be mated to each other or plugged with appropriate watertight caps.

⚠ Warning: Cutting the power optimizer input or output cables is prohibited and will void product warranty.

⚠ Warning: Do not connect / disconnect DC connectors or wiring while under load.

⚠ Warning: Only connectors of the same make and model may be connected together.

Note: Modules with SolarEdge power optimizers output a low safety voltage before the inverter is turned ON. As long as the power optimizers are not connected to the inverter or the inverter is turned OFF, each power optimizer will output a safe voltage of 1V ($\pm 0.1V$).

MOUNTING THE POWER OPTIMIZERS

1. Determine and mark the power optimizer mounting locations on the rail:
 - a. Power optimizers should be spaced approximately 1009 mm apart on the rail. See figure below.
 - b. Power optimizers must be positioned so that they maintain a 25 mm clearance distance between the power optimizer and other surfaces to allow for heat dissipation.

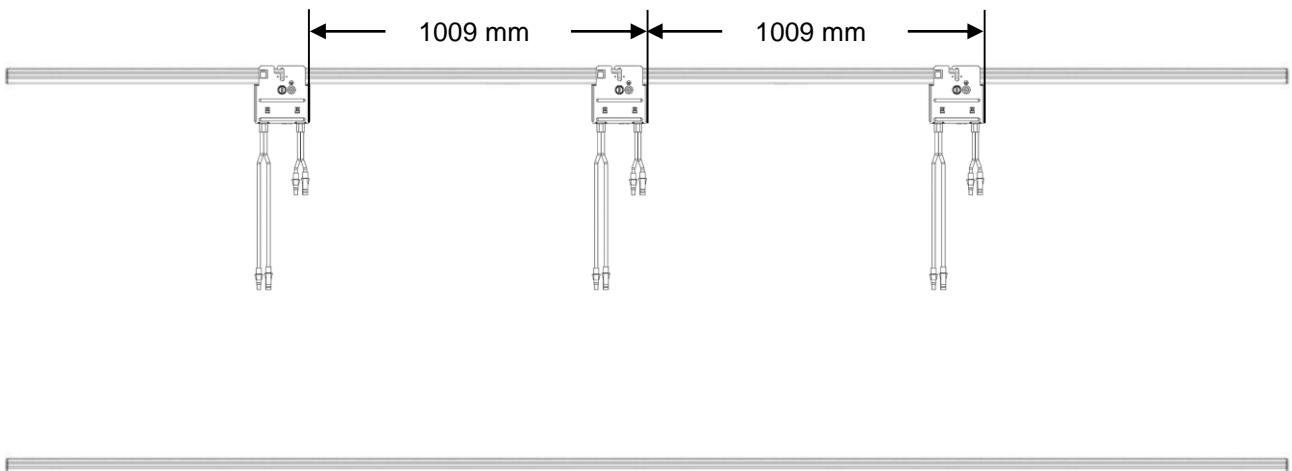

Note: Figure is not to scale.

Note: Ensure clearance between power optimizers and PV module junction boxes.

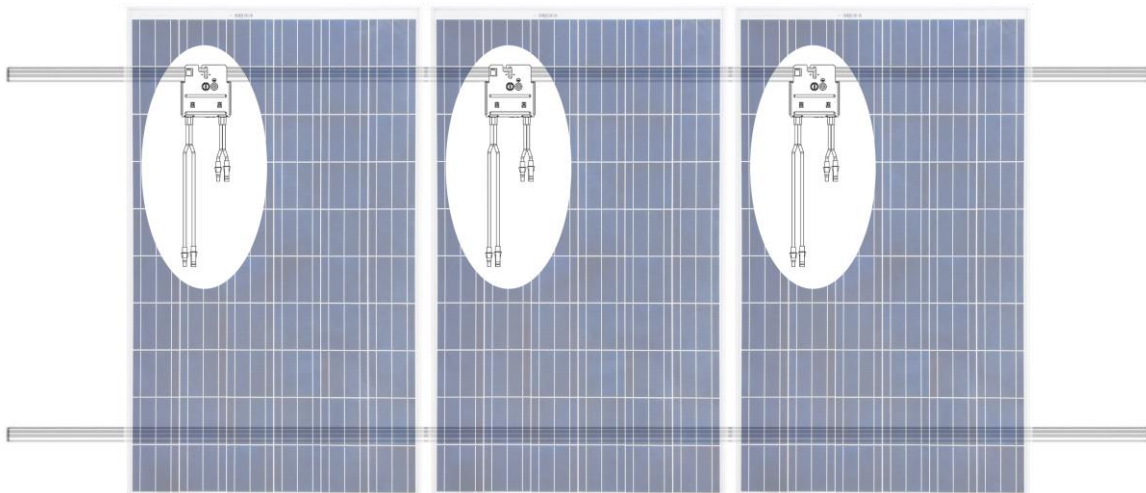

- Attach each power optimizer to the mounting rail using the Z-module assembly provided in the BOS kit. See figure below. Apply a tightening torque of 9.5 Nm.



Z-module assembly

Note: It is recommended that the power optimizers be placed face down to ensure clearance between the back of modules and power optimizers. See figure below.

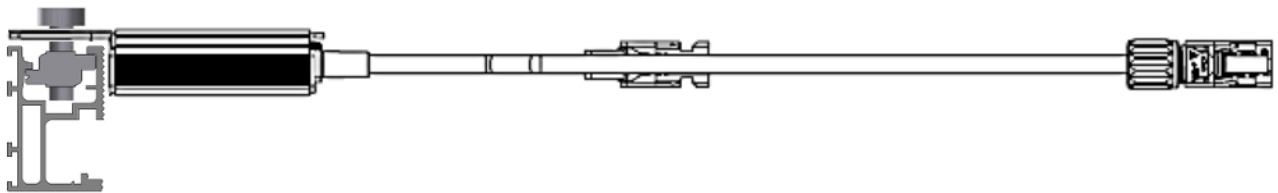

Note: Figure is not to scale.

- Verify that each power optimizer is securely attached to the rail.
- Record power optimizer serial numbers and locations. This can be achieved through the use of a paper template or SolarEdge smartphone application. Refer to SolarEdge supplied documentation for more information.

POWER OPTIMIZER WIRING PROCEDURE

⚠ Warning: Use insulated tools and wear appropriate PPE when performing wiring to prevent the risk of electric shock.

PV Module and power optimizer DC plug connectors are connected as follows:

Firmly push positive (+) plug into negative (-) plug until an audible “click” is heard, and then try to pull plugs apart. Incorrectly connected plugs will come apart whilst correctly connected plugs will not come apart unless the locking latches on either side of the positive (+) plug are depressed using an unlocking tool whilst plugs are pulled apart.

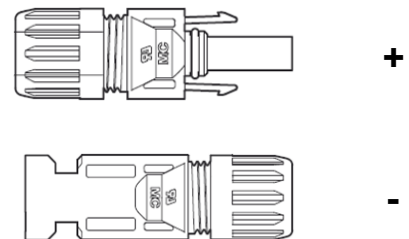

Note: Pull on plugs, do not pull on wiring.

⚠ Warning: Do not connect / disconnect DC connectors or wiring while under load.

⚠ Warning: Only connectors of the same make and model may be connected together.

The following procedure should be adhered to whilst wiring power optimizer strings to prevent the risk of electric shock or inadvertent short circuiting of live cables whilst wiring the Rooftop DC Isolator:

- Two extension leads per string should be constructed using the DC extension cable provided in the BOS Kit. One should be short to connect from the first power optimizer in the string to the DC isolator. The other should be sufficiently long to plug the end power optimizer in the string to the DC isolator (see the example schematic below).

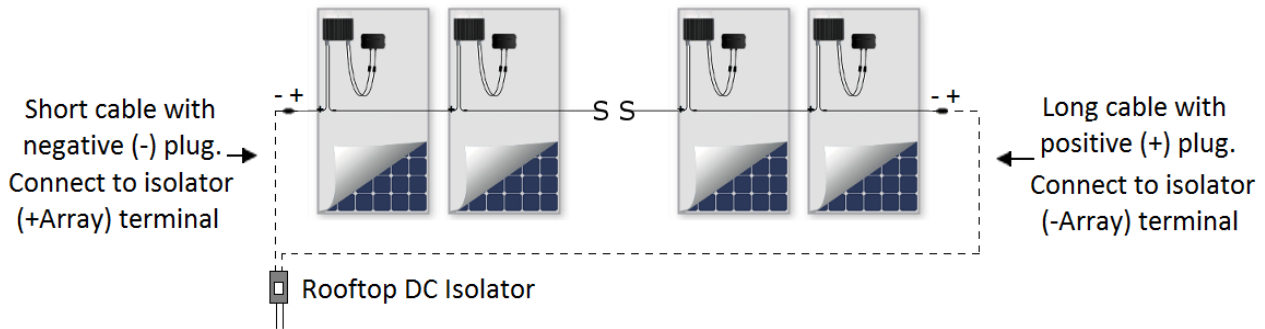

2. Ensure the Rooftop DC Isolator is in the OFF position, strip 12 mm of insulation from the end of each extension lead and connect the two extension leads to the Rooftop DC Isolator terminals. The Rooftop DC Isolator should be wired in a consistent manner. Refer to “DC Isolator Wiring” on page 24.
3. Connect the first power optimizer’s positive output (+) cable plug to the Rooftop DC Isolator extension cable negative (-) plug. See figure below for power optimizer cable plug illustration.

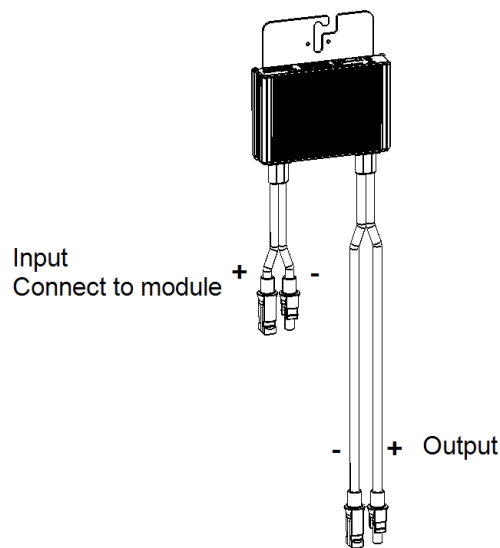

Note: Image is for illustration purposes only. Refer to the label on the product to identify the plus and minus input and output connectors.

4. Connect each power optimizer’s negative output (-) cable to the following power optimizer’s positive output (+) cable.
5. Connect the last power optimizer’s negative output (-) cable to the Rooftop DC Isolator extension cable positive (+) plug.
6. Connect the first power optimizer’s input connectors to the first module’s connectors.
7. Repeat Step 6 for each module and power optimizer in the string.
8. Verify proper power optimizer connection by measuring the voltage of each string individually.

Note: Each power optimizer in the string will output a safe voltage of 1 V (± 0.1 V). For example: 9 power optimizers connected in a single string should output a safe voltage of 9 V (± 0.9 V).

Note: Ensure the modules are exposed to sunlight during this process; otherwise, the power optimizers may not be powered.

9. Repeat Steps 1 - 8 for each string in the PV array.
10. Your PV array wiring is now complete.

Note: The Rooftop DC Isolator should still be in the OFF position at the completion of this stage of the installation. It should not be turned ON until the correct stage of commissioning. Refer to “Solar Isolation Device(s) Test – Rooftop DC Isolator(s)” on page 43.

PV MODULES

PV MODULES

PV modules generate electricity as soon as they are exposed to sunlight and as such they can represent a danger. All warnings in this manual must be observed when handling solar modules to avoid the risk of fire, sparking and/or electrocution.

If modules are connected in series (summing voltage) the combined voltage must not exceed the inverter's maximum input voltage rating. For the maximum number of series connected modules permissible, refer to the relevant wiring diagram in this document for the inverter model installed.

The Solahart mounting system requires the use of modules of equal thickness for correct clamping.

Note: Ensure only modules of the same type (model & thickness) are clamped side-by-side and electrically connected.

MODULE HANDLING

Modules should be handled with care and protected from damage at all times. All warnings and instructions on the packaging should be observed. Follow these guidelines when unpacking, transporting or storing the modules:

- Note module serial numbers before installation and record serial numbers in the system documentation.
- Carry modules using both hands and do not use the junction box or electrical wiring as a grip.
- Do not subject modules to loads or stresses.
- Do not stand on the modules.
- Do not use modules that have been dropped.
- Keep all electrical contacts clean and dry.
- Store modules in a dry and properly ventilated room.
- Do not use sharp or pointed objects to mark module surface or module anodising.
- Never apply paints, adhesives, or detergents to the rear laminate of the modules.
- Never attempt to disassemble modules, modify or adapt the modules or labels in any way as this will void the warranty.
- Do not drill additional holes in any part of the module. Drilling holes voids the product warranty.

⚠ Warning: Do not use modules which are broken or damaged. If the module front glass is broken or laminate back sheet is damaged in any way, hazardous voltages may be exposed.

STRING WIRING PROCEDURE

Note: If you have completed the "Power Optimizer Wiring Procedure" on page 26, proceed to "Earthing" on page 29.

⚠ Warning: Use insulated tools and wear PPE when performing wiring to prevent the risk of electric shock. It is suggested that modules be covered with an opaque material during wiring to reduce the voltage generated by the string.

PV Module DC plug connectors are connected as follows:

Firmly push positive (+) plug into negative (-) plug until an audible "click" is heard, and then try to pull plugs apart. Incorrectly connected plugs will come apart whilst correctly connected plugs will not come apart unless the locking latches on either side of the positive (+) plug are depressed using an unlocking tool whilst plugs are pulled apart.

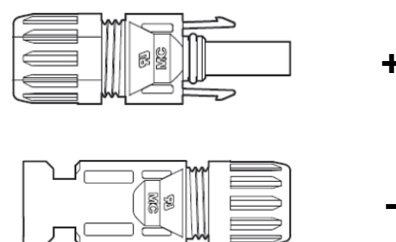

Note: Pull on plugs, do not pull on wiring.

⚠ Warning: Do not connect / disconnect DC connectors or wiring while under load.

⚠ Warning: Only connectors of the same make and model may be connected together.

The following procedure should be adhered to whilst wiring module strings to prevent the risk of electric shock or inadvertent short circuiting of live cables whilst wiring the Rooftop DC Isolator:

1. Two extension leads per string should be constructed using the DC extension cable provided in the BOS Kit. One should be short to connect from the first module in the string to the DC isolator. The other should be sufficiently long to plug the end module in the string to the DC isolator (see the example schematic below).
2. Ensure the Rooftop DC Isolator is in the OFF position, strip 12 mm of insulation from the end of each extension lead and connect the two extension leads to the Rooftop DC Isolator terminals. The Rooftop DC Isolator should be wired in a consistent manner. Refer to “DC Isolator Wiring” on page 24.
3. Connect the first module positive (+) cable plug to the Rooftop DC Isolator extension cable negative (-) plug.
4. Connect each module’s negative (-) cable to the following module’s positive (+) cable as modules are being installed until the halfway point is reached i.e. fourth module in an eight module string.
5. Install and connect the remaining modules, but do not make the halfway connection, i.e. in an eight module string do not connect the fourth module negative (-) cable to the fifth module positive (+) cable (refer to wiring diagram below). These two cables will be connected at the end of this procedure.
6. Connect the last module’s negative (-) cable to the Rooftop DC Isolator extension cable positive (+) plug.
7. Complete the circuit by connecting the two string halves together by connecting the positive (+) and negative (-) cables of the two modules left previously disconnected in step 5.

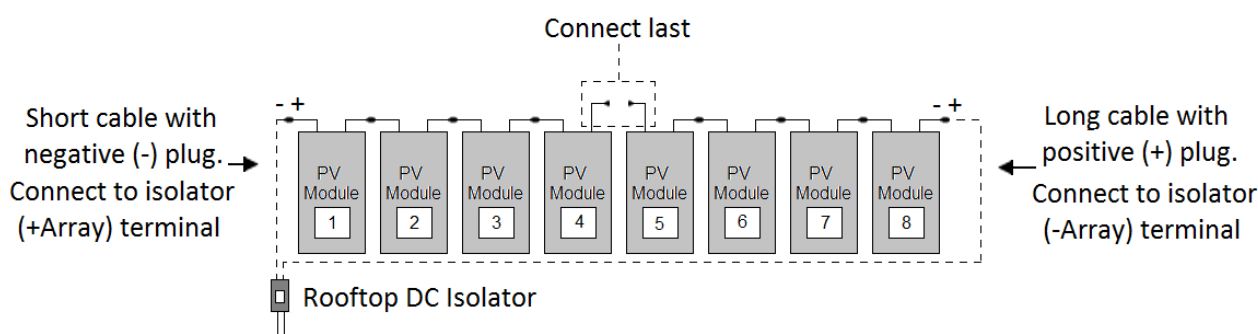

Note: Modules may be connected in a different order provided that all modules in a string are connected in series.

Note: The Rooftop DC Isolator should still be in the OFF position at the completion of this stage of the installation. It should not be turned ON until the correct stage of commissioning. Refer to “Solar Isolation Device(s) Test – Rooftop DC Isolator(s)” on page 43.

EARTHING

All modules and rails must be earthed. Refer to “Earthing Arrangements – All Systems” on page 9. Earthing connections must be made by a suitably qualified person according to the relevant standards outlined on page 4. It is also recommended that a reliable lightning protection system be installed.

Stainless steel serrated washers must be used so the rail anodising is pierced, providing good electrical continuity. Stainless steel nuts, bolts and washers must be used and all ferrous metal in conductive connections should be specially treated to prevent corrosion (i.e. by spray painting or coating with a galvanising paint). Refer also to “Earthing Arrangements – All Systems” on page 9.

Earthing plates

To earth modules and rails, use earthing plates supplied when mounting modules. Install earthing plates in accordance with the following instructions. When installed correctly, earthing plates will provide earth bond continuity between rails and modules whilst allowing removal of a module without affecting the earthing integrity of other components in the system. The rails must then be earthed by connecting a suitably sized earth wire. Refer to “Earthing Arrangements – All Systems” on page 9.

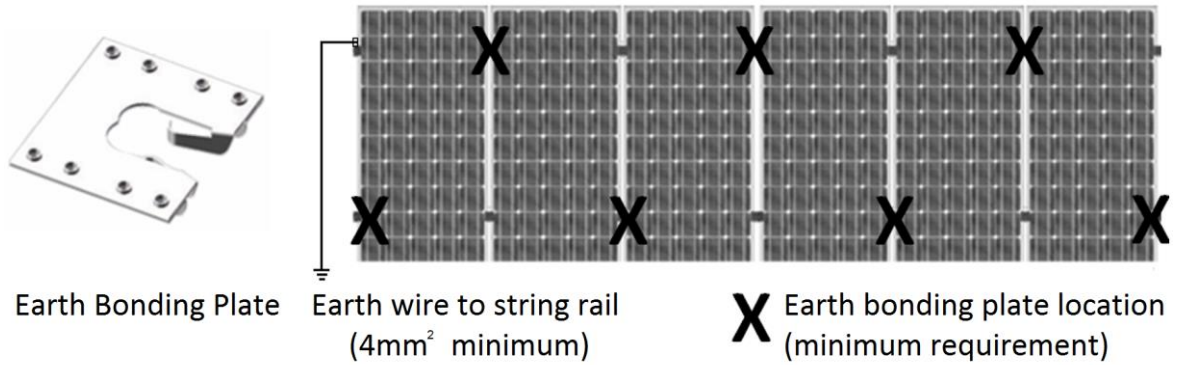

⚠ Warning: Only Solahart approved earthing plates are to be used.

⚠ Warning: Module frames must be located on top of earthing plate earth bond protrusions.

⚠ Warning: Earthing plates are intended for single use only and must not be reused.

⚠ Warning: If rails are not of a continuous length, or rail splices do not provide satisfactory earth continuity, earth bond jumper cables must be used across rails or rail splices or each section of rail must have an earth wire connection.

MODULE MOUNTING

Ensure a minimum clearance of 60 mm between the outer surface of the roof and any part of the module to allow sufficient airflow beneath the modules and adequate cooling of the modules.

Module cables must be installed so that any water will run away from the junction box.

Each corner of the module frame has small drainage holes to allow water caused by rain or snow melt to exit the frame easily and to minimize damage caused by freezing and thawing. Please note:

- The drainage holes must not be used for mounting the module.
- Ensure the drainage holes are clear at all times.

Fastening the modules to the mounting structure

Each module must be securely fixed to the mounting structure at a minimum of four points. The distance between the end clamp and the end of the rail should be a minimum of 25 mm. The mounting clamps must be fastened so the clamp lies completely within the range of shown below for each type of module.

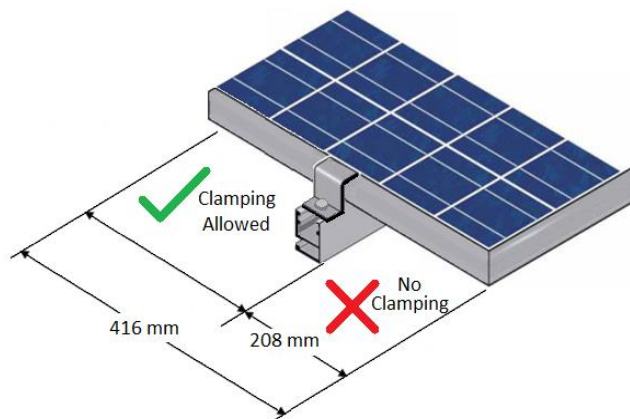

Note: Figure is not to scale

MODULE MOUNTING PROCEDURE

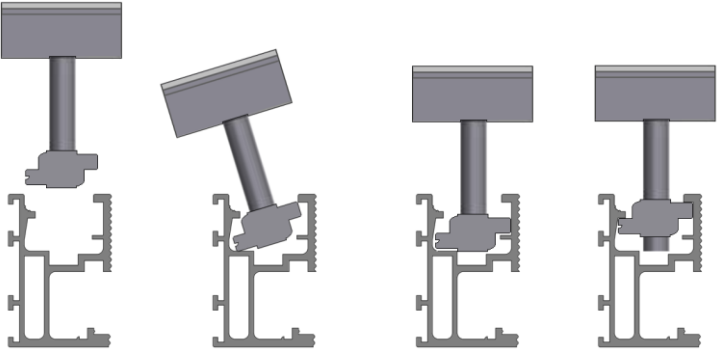
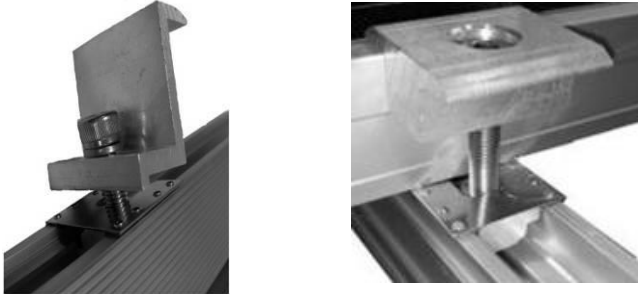
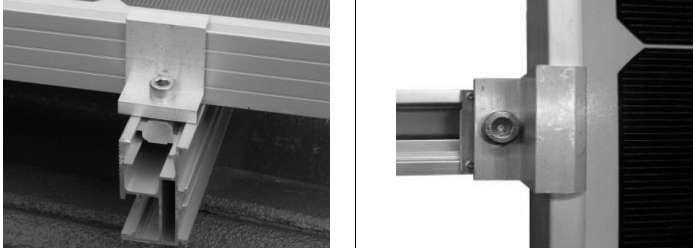
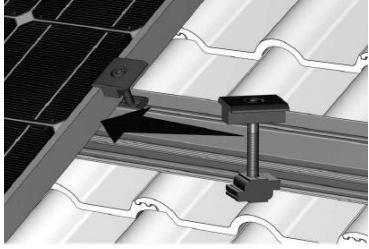
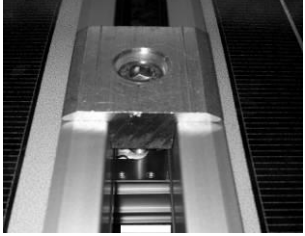
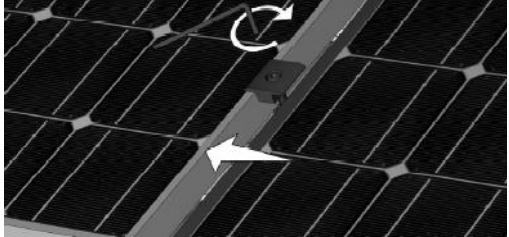
<p>1. Mid clamps and end clamps can be inserted into the rail by following the procedure shown, making sure the spring washer is correctly in place.</p> <p>For easy use of Z-modules, ensure Allen head bolt threads do not project through lower side of Z-module, so the Z-module is free to move along the rail.</p>	
<p>2. In positions where earthing plates are required, slide the earthing plate over threaded section of Allen head bolt and press earthing plate into rail so that rail retention tabs hold the earthing plate in position.</p>	
<p>3. Install PV module under end clamps. Ensure end clamps are tight against the module and are at least 25 mm from the rail ends. For end clamps with earthing plates, ensure the frame of the module is located on top of the protrusions of the earthing plate. Tighten end clamp bolts to 21 Nm.</p>	
<p>4. Place a mid clamp with Z-module and Allen head bolt in each rail and slide into position. Ensure that the mid clamp is tight against the module. For mid clamps with earthing plates, ensure the frame of the module is located on top of the protrusions of the earthing plate. Fasten loosely (approx 2 – 3 turns).</p>	
<p>5. Place the next module onto the rail and slide the module into the mid clamps. In positions where earthing plates are required, ensure both module frame edges are located on top of the protrusions of the earthing plate</p>	
<p>6. Tighten each mid clamp Allen head bolt to 21 Nm.</p> <p>Repeat steps 4 to 6 for each remaining module in the row.</p>	

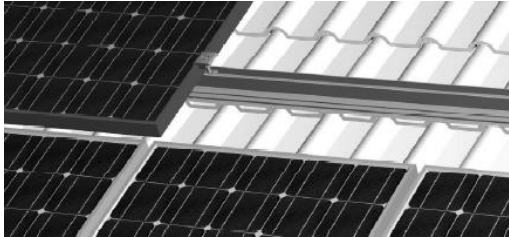
<p>7. Place an end clamp into the end of each rail. Ensure that the end clamps are tight against the module and are at least 25 mm from the rail ends. In positions where earthing plates are required, ensure the frame of module is located on top of the protrusions of the earthing plate. Tighten end clamp bolts to 21 Nm.</p>	
<p>8. Repeat the steps 3 - 7 for each row of modules.</p> <p>Mid clamps may be temporarily placed between rows to ensure 18 mm uniform spacing between rows.</p>	

Module installation is now complete.

INVERTER



For inverter installation instructions and warranty exclusions refer to the documents supplied with the inverter. The following points must also be observed when installing the inverter:

⚠ Warning: Inverters have masses between 14 kg and 27 kg. Proper safe handling procedures must be employed when installing or handling these inverters.

- Inverters must be sheltered from direct sunlight and other sources of heat.
- Inverters must be installed in a well-ventilated place so as to allow good circulation of air around the unit. Avoid places where air cannot circulate freely around the unit.
- The inverter must not be installed in a location accessible to children.
- The mounting structure must be capable of supporting the inverter weight.
- If the inverter is to be mounted on a combustible surface such as wood, a heat resistant backing (such as a fibre cement board) must be installed behind the inverter. Backing must extend a minimum of 20 mm past all edges and sides of the inverter.
- Inverter mounting clearances and requirements outlined in the relevant inverter documentation must be adhered to. Ignoring recommended mounting instructions can cause permanent damage to the inverter from water ingress and can reduce inverter efficiency due to inadequate heat dissipation..
- Sealing plugs provided with the inverter must be inserted into any unused string inputs to maintain the inverter's IP rating. For SMA inverters, sealing plugs must be inserted into the rear of the Sunclix DC plug connectors. For Power-One/ABB and SolarEdge inverters verify the presence of watertight rubber cap seals on DC input connectors and install them should they be absent.
- For the Power-One/ABB PVI series of inverters ensure that:
 - For multiple string systems, the inverter is configured for 'independent' channels (factory default setting).
 - For single string systems, the inverter is configured for 'parallel' channels. Refer to inverter documentation for detailed instructions on configuration of channels.
- When installing an inverter with a StorEdge Connection Unit, do not install fuses if a battery is not installed. Leave all fuses in their original packaging behind the plastic cover inside the StorEdge Connection Unit, clear from all electrical wires and components.

MULTI-CONTACT DC CONNECTIONS

Multi-Contact Safety Locking Clips must be installed over the negative connectors of all Multi-Contact DC connections at the inverter. The purpose of these devices is to prevent accidental disconnection of live DC at the inverter. When the Safety Locking Clip is in place, a custom tool is required to separate the connectors.

Multi-Contact (MC) Positive (+) Connector: PV-KBT4	Multi-Contact (MC) Negative (-) Connector: PV-KST4	Multi-Contact (MC) Safety Locking Clip: PV-SSH4
		

AC CABLE SIZING TABLE

Inverter AC cabling must be sized and installed in accordance with AS/NZS 3000, AS/NZS 3008 and any local applicable codes. Cables selected must have an appropriate current carrying capacity for the maximum fault current output of the inverter, and the Inverter AC isolator, taking into consideration relevant de-rating factors. For the nominal trip current of the AC breaker, refer to the “Wiring Diagrams” beginning on page 6.

Inverter	
Model	Maximum AC Fault Current (A)
SB 1.5-1 VL-40	12.0
SB 2.5-1 VL-40	19.0
PVI-3.0-TL-OUTD	25.0
SB3.0-1AV-40	29.0
SB3000TL-21	34.0
SB4.0-1AV-40	29.0
SB4000TL-21	34.0
PVI-4.2-TL-OUTD	25.0
PVI-5000-TL-OUTD	40.0
SB5.0-1AV-40	29.0
SB5000TL-21	34.0
SE5000*	27.0

*This model may have suffixes indicating different options and functionality.

Inverter AC cabling must have a voltage drop or rise less than 1% in accordance with AS/NZS 5033. For common PVC/PVC cable types operating at 75°C on a 230 V single-phase circuit, the following table provides for a voltage variation of less than 1%.

Inverter Model	Conductor cross section				
	2.5 mm ²	4.0 mm ²	6.0 mm ²	10.0 mm ²	16.0 mm ²
Maximum cable length (m)					
SB 1.5-1 VL-40	18.3	29.3	N/A	N/A	N/A
SB 2.5-1 VL-40	11.6	18.6	N/A	N/A	N/A
PVI-3.0-TL-OUTD	Refer Power-One/ABB Quick Installation Guide				
SB3000TL-21	9.8	15.8	23.5	39.6	N/A
SB3.0-1AV-40	9.8	15.8	23.5	39.6	N/A
SB4000TL-21	7.4	11.8	17.6	29.6	N/A
SB4.0-1AV-40	7.4	11.8	17.6	29.6	N/A
PVI-4.2-TL-OUTD	Refer Power-One/ABB Quick Installation Guide				
PVI-5000-TL-OUTD	Refer Power-One/ABB Quick Installation Guide				
SB5000TL-21	6.4	10.3	15.3	25.8	N/A
SB5.0-1AV-40	5.9	9.4	14.1	23.7	N/A
SE5000*	4.7	7.6	11.3	19.1	N/A

*This model may have suffixes indicating different options and functionality.

Note: If the installation requires different cabling or has installation conditions different to those specified above, the installer must undertake appropriate calculations to ensure the cabling is correctly sized.

EARTH FAULT ALARMS

The installation of an earth fault alarm compliant with AS/NZS 5033 requirements is mandatory for all arrays. Solahart inverters are able to communicate an earth fault in three different ways:

1. Inverter display
 - Some Solahart inverters display an Earth Fault Alarm message on the inverter display when an earth fault is present. Consult the specific inverter installation manual for details of the error message display on the inverter
 - Examples:
 - SMA inverter display
 - ABB inverter display
 - SolarEdge inverter display
2. Inverter Built-in Audible Alarm
 - Some Solahart inverters come with built-in audible alarm which is triggered when an earth fault is present.
 - Examples:
 - SMA Smart Connect Series (SB3.0-1AV-40, SB4.0-1AV-40, SB5.0-1AV-40)
3. External alarm – Email Alert
 - Some Solahart inverters are able to communicate with a web portal that can be configured to send an email alert to the system owner when an earth fault is present.
 - Examples:
 - SMA Webconnect
 - ABB WIFI logger card
 - SolarEdge Wi-Fi kit or integrated Ethernet
4. External alarm – Audible or Visual Alarm
 - Some Solahart inverters can switch a relay when an earth fault is present. The relay can be connected to an audible or visual alarm that meets AS/NZS 5033 requirements.
 - Examples:
 - SMA multi-function relay
 - ABB configurable relay

SMA inverter display

It may be possible to comply with earth fault alarm requirements without additional components. In this instance, the visual warning light and error information on the graphical display can be relied upon; however, this method of compliance requires the inverter be installed in a compliant location according to AS/NZS 5033 and/or local regulator.

SMA Webconnect

The SMA Webconnect, SWDM-10, comes factory installed in all our current SMA single-phase inverters.

The Webconnect is a cable-based type of communication based on the Ethernet standard. The Webconnect enables the inverter to exchange data with SMA Sunny Portal which facilitates data monitoring and fault communication via email.



To set up the Webconnect, proceed as follows:

1. Prior to PV system commissioning, connect the Webconnect to the SMA Webconnect (SWDM-10) PV system owner's internet connected router through the use of a network cable as described in the SWDM-10 installation instructions
2. Commission the PV system as outlined in the Solahart Owner's Guide and Installation Instructions
3. Commission and register the PV system on SMA Sunny Portal through the Plant Setup Assistant. An internet connected laptop, tablet or smartphone is required.
4. Once the system has been successfully registered, login to Sunny Portal
5. Ensure to activate earth fault alarm reporting on SMA Sunny Portal

SMA multi-function relay

On the occurrence of an inverter fault, the relay can be used to trigger an external audio and/or visual alarm. Please follow the instructions provided in the inverter product manual for maximum ratings, requirements and instructions on how to utilise the relay connection.

Note: SB 1.5-1 VL-40, SB 2.5-1 VL-40, SB3.0-1AV-40, SB4.0-1AV-40 and SB5.0-1AV-40 inverters do not have any relay functionality.

ABB INVERTER DISPLAY

It may be possible to comply with earth fault alarm requirements without additional components. In this instance, the visual warning light and error information on the graphical display can be relied upon; however, this method of compliance requires the inverter be installed in a compliant location according to AS/NZS 5033 and/or local regulator.

ABB Wifi logger card (VSN300)

The ABB Wifi logger card, VSN300, is an add-on card compatible with all ABB inverters supplied by Solahart. The Wifi logger card is a Wi-Fi based communication device that enables the inverter to exchange data with ABB’s Auroravision web portal which facilitates data monitoring and fault communication via email.

The general installation process of the Wifi logger card is outlined below:

1. Prior to PV system commissioning, install the Wifi logger card as per supplied instructions
2. Commission the PV system as outlined in the Solahart Owner’s Guide and Installation Instructions
3. Commission the Wifi logger card as per supplied instructions. An internet connected and Wi-Fi enabled laptop, tablet or smartphone is required.
4. During the commissioning procedure, you will be asked to insert SolarEdge Wi-Fi Kit Aurora Vision access credentials. Please enter the login credentials supplied by the Solahart dealer or create a new profile for the PV system owner.
5. Once the system has been successfully registered, ensure the report configuration of AS/NZS 5033 is correctly activated.

ABB configurable relay

All ABB inverters currently supplied by Solahart are delivered with a configurable relay connection that on the occurrence of an inverter fault can be used to trigger an external audio and/or visual alarm. Please follow the instructions provided in the inverter product manual for maximum ratings, requirements and instructions on how to utilise the configurable relay connection.

SolarEdge inverter display

It may be possible to comply with earth fault alarm requirements without additional components. In this instance, the visual warning light and error information on the graphical display can be relied upon; however, this method of compliance requires the inverter be installed in a compliant location according to AS/NZS 5033 and/or local regulator.

SolarEdge Wi-Fi kit

The SolarEdge Wi-Fi kit is an add-on card compatible with all SolarEdge inverters supplied by Solahart. The Wi-Fi based communication device enables the inverter to exchange data with SolarEdge’s web monitoring portal which facilitates data monitoring and fault communication via email.

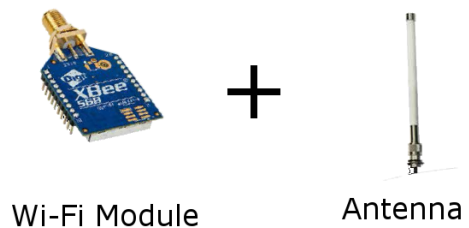

The general installation process of the Wi-Fi kit is outlined below:

1. Prior to PV system commissioning, install the Wi-Fi kit as per supplied instructions
2. Commission the PV system as outlined in the Solahart Owner’s Guide and Installation Instructions
3. Commission the Wi-Fi kit as per supplied instructions.
4. During the commissioning procedure, you will be asked to register the system. Please enter the login credentials supplied by the Solahart dealer or create a new profile for the PV system owner.
5. Once the system has been successfully registered, ensure the report configuration of AS/NZS 5033 is correctly activated.



ABB Wifi Logger Card (VSN300)

METER (SOLAREGE ONLY)

Note: The meter is an optional accessory for use in battery systems and for zero export requirements.

MOUNTING

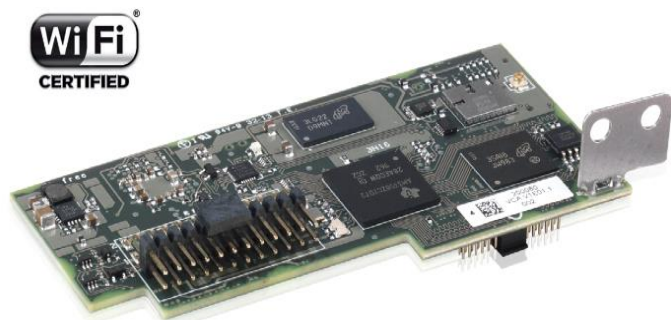
⚠ Warning: Protect the meter from temperatures below $-30\text{ }^{\circ}\text{C}$ or above $55\text{ }^{\circ}\text{C}$, excessive moisture, dust salt spray, or other contamination, using an IP rated enclosure if necessary

⚠ Warning: Meter must be installed in an electrical service panel, an enclosure or a limited access electrical room.

⚠ Warning: Do **NOT** use the meter as a drilling guide; the drill chuck can damage the screw terminals and metal shavings may fall into the connectors

The SolarEdge meter can be mounted in one of two methods:

1. Attached directly onto a substrate through the mounting holes
2. Attached to a DIN rail via mounting clips supplied with the meter

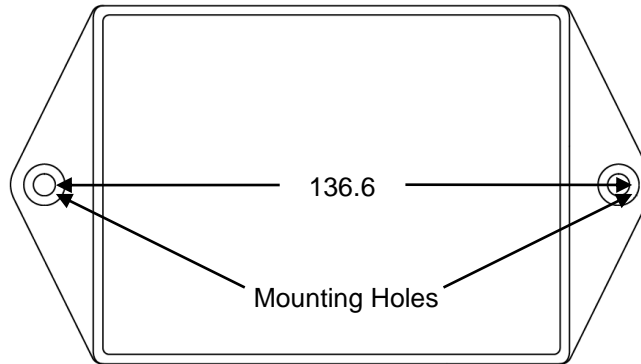

Note: Figure is not to scale.

WIRING AT METER

⚠ Warning: Isolate all sources of supply before attempting to wire the meter.

⚠ Warning: Do not place more than one voltage wire in a screw terminal.

The wiring procedure for SolarEdge meters is as follows:

1. Install cabling for each line voltage to the appropriate phase.
2. Install cabling for neutral and ground.
3. Install cabling for the current transformers (CTs).
 - a. To minimize current measurement noise, minimize the length of the CT wires.
 - b. Ensure to match the CTs with their corresponding voltage phases.
4. Install each CT around the conductor to be measured.
 - a. Find the arrow or label "THIS SIDE TOWARD SOURCE" on the CT and point towards the grid.
5. Install cabling for the RS485 communications line
 - a. Take note of the difference between the inverter and SolarEdge connector labelling

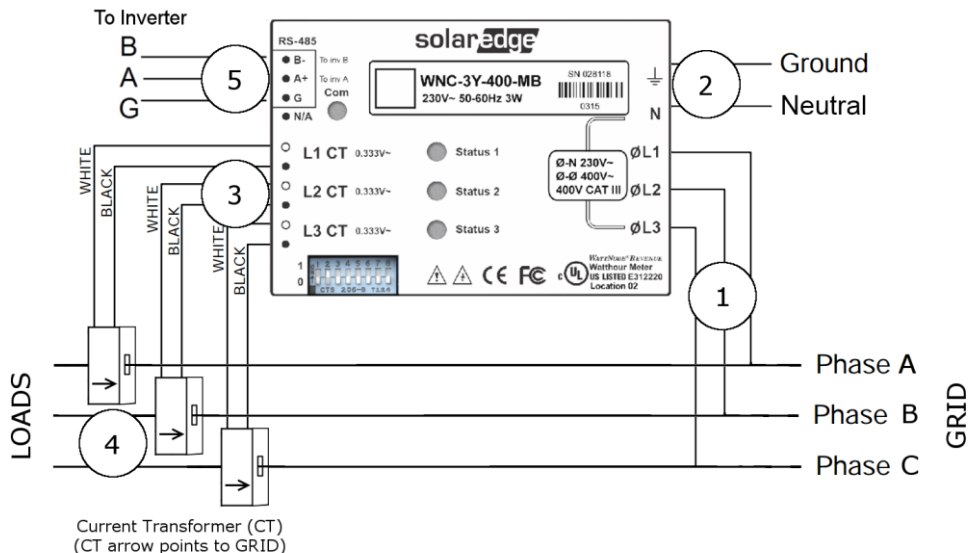

SETTING DIP SWITCHES

1. Set DIP switches on the meter as described in the figure below.

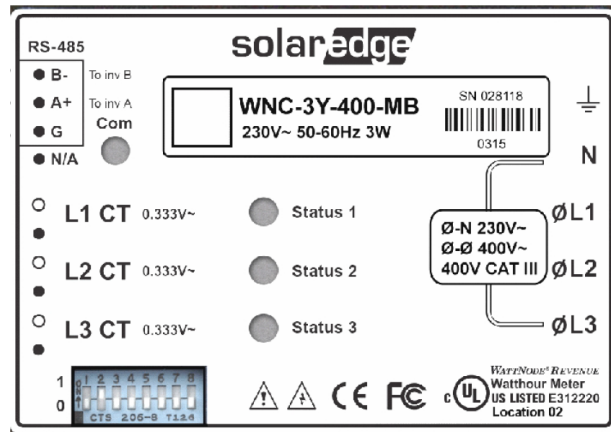

WIRING AT INVERTER

1. Remove the seal from one of the openings in the communication gland #2 at the bottom of the inverter and insert the RS485 wires from the meter through the opening.

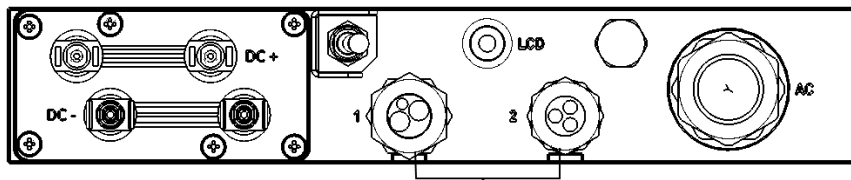

Communication glands

For an inverter / StorEdge Connection Unit with conduit entries, route the RS485 wires from the meter through the opening in the right hand side of the unit.

2. Remove the 9-pin RS485 connector located on the communication board.

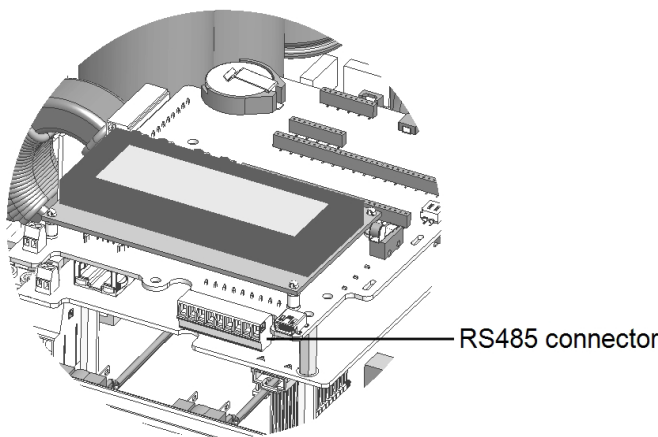

SolarEdge Inverter

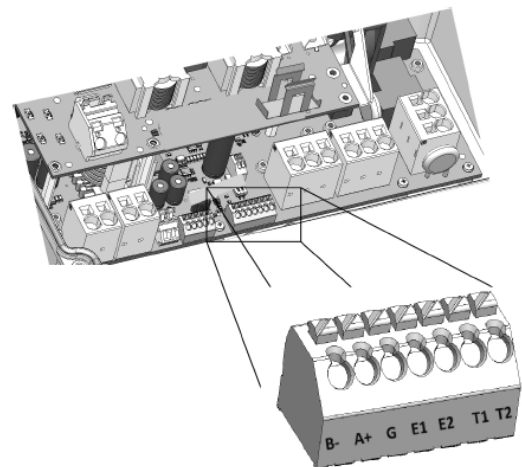

SolarEdge Inverter with StorEdge Connection Unit

3. Connect the wires from the meter.
 - a. If you have a SolarEdge branded meter, connect as illustrated below:

Inverter RS485 connector

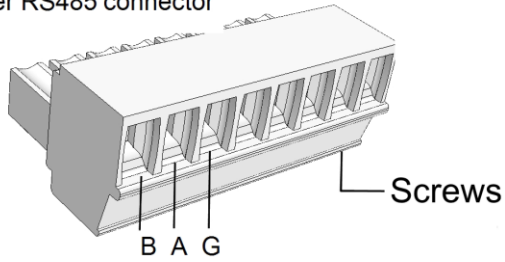

B — B-
 A — A+
 G — G

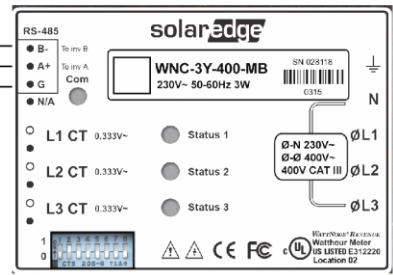

4. If the SolarEdge device is at the end of the RS485 bus, terminate the inverter by switching a termination DIP-switch inside the inverter to ON (top position). The switch is located on the communication board is marked SW7 as illustrated below:



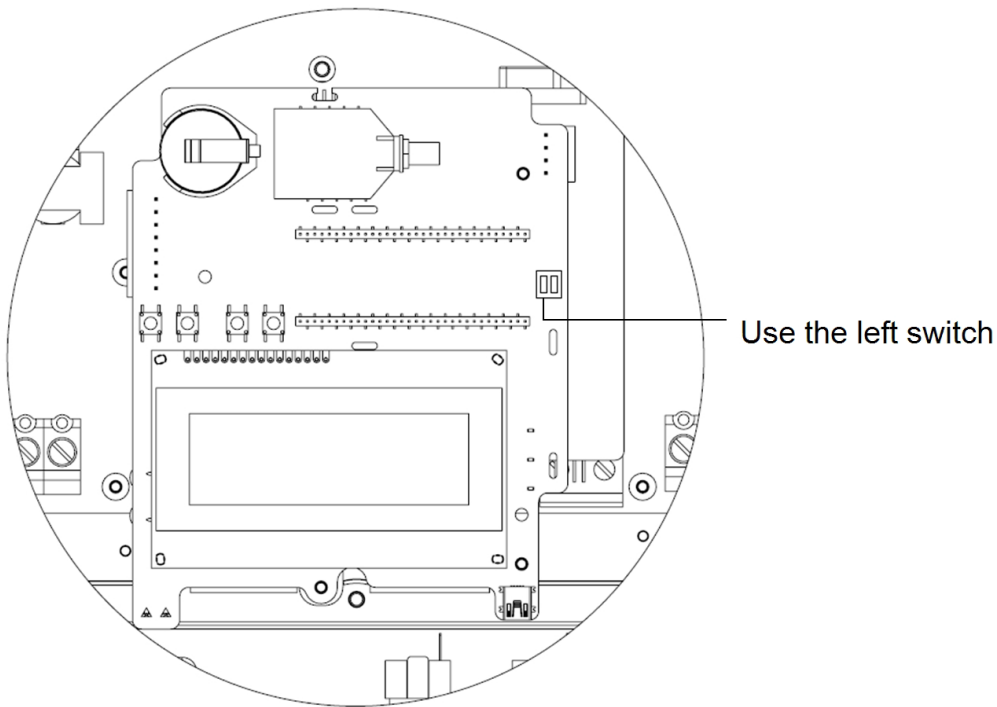

Inverter





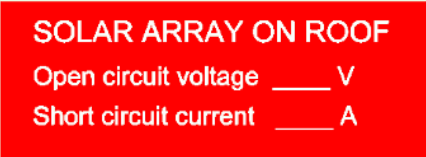

LABELLING

This information is supplied here as a guide only. Additional labels may be required depending upon the installation and local requirements. Labels must be constructed to AS 1319 and installed according to AS 4777.1, AS/NZS 5033 and any local regulations. Refer to aforementioned standards for more information.

The purpose of labelling is to clearly indicate that the electrical installation has multiple supplies and which circuits are affected by these supplies. Labelling also identifies the components that isolate the various supplies. Labels relating to the PV system must be placed on the switchboard to which the PV system is directly connected. If the PV system is directly connected to a distribution board, additional labels must also be placed on the main switchboard and all intermediate distribution boards. The following table details labels that are supplied in Solahart PV Systems.

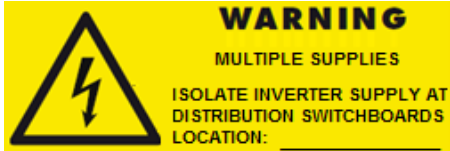
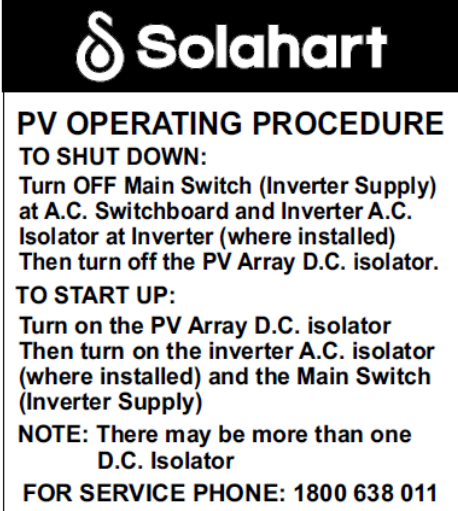
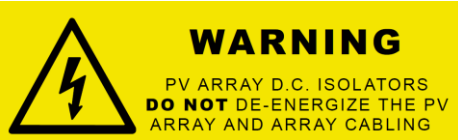
Label	Colour	Location
	Black text on yellow background	Prominent position on the switchboard where the inverter is connected to
	White text on red background	Adjacent to main switch to grid supply
	White text on red background	Adjacent to the isolator for normal supply to the distribution board (applicable only when the inverter is connected to a distribution board)
	White text on red background	Solar inverter main switch if inverter is located adjacent to switchboard
 <p>Solar plant location to be entered by installer</p>	White text on red background	<div style="border: 1px solid black; padding: 5px; width: fit-content; margin: 0 auto;">OR</div> <p>Solar inverter main switch if inverter is not located adjacent to main switchboard</p>
 <p>Values to be entered by installer</p> <p>SOLAREEDGE SYSTEMS ONLY:</p> <p>Open circuit voltage: Inverter maximum DC operating voltage</p> <p>Short circuit current: Inverter maximum input current</p>	White text on red background	Prominent position adjacent to meter box and building's main switchboard

Label	Colour	Location
	<p>Reflective white text on reflective green background</p>	<p>Prominent position on or adjacent to the meter box</p>
	<p>Black text on white background</p>	<p>Rooftop and inverter Solar DC isolators</p>
	<p>Black text on white background</p>	<p>Inverter AC isolator</p>
 <p>Distribution board number to be entered by installer i.e. DB1</p>	<p>Black text on yellow background</p>	<p>Main switchboard (applicable when the inverter is connected to a distribution board)</p>
	<p>Black and white</p>	<p>Prominent position adjacent to the inverter</p>
	<p>Black text on yellow background</p>	<p>Added below the shutdown sign (Solahart PV Operating Procedure)</p>
	<p>Black text on yellow background</p>	<p>Prominent position adjacent to the inverter</p>

COMMISSIONING

Systems must be commissioned according to AS/NZS 5033. Commissioning tests are required to ensure that the system complies with the aforementioned standard. Commissioning information is provided here as a guide only and it is the installer's responsibility to ensure that the requirements of AS/NZS 5033 are met. A copy of the relevant commissioning documents must be provided to the owner and a copy kept by the installer.

Before starting any of the tests below, ensure that:

- The Main Switch (Inverter Supply) at the AC switchboard is in the OFF position.
- The Inverter AC Isolator at the inverter is in the OFF position (if installed).
- The Inverter DC Isolator(s) at the inverter are in the OFF position.
- The Rooftop DC Isolator(s) are in the OFF position.

⚠ Warning: Dangerous DC voltages may be present during the following commissioning procedure. Appropriate personal protective equipment should be used.

VERIFICATION OF MODULE AND RAIL EARTH RESISTANCE

This test is performed to ensure modules and rails are correctly earthed.

1. Using a multimeter set on the ohms scale, measure between each module and the system earth wire. Earth resistance must be 0.5 Ω or less.
2. Using a multimeter set on the ohms scale, measure between each rail and the system earth wire. Earth resistance must be 0.5 Ω or less.

STRING OPEN CIRCUIT VOLTAGE (V_{oc}) TEST

This test is performed to ensure the wiring polarity and continuity of the PV array is correct. Measurements should be made under stable irradiance conditions close to solar noon if possible. Where multiple strings are installed, this test procedure must be repeated for each string.

The voltage measurement obtained should be the number of modules in the string multiplied by the V_{oc} of one module i.e. for a string with 9 X REC280TP modules: String $V_{oc} = 9 \times 39.2 \text{ V DC} \approx 353 \text{ V DC}$.

1. Ensure that the Inverter AC Isolator(s) are in the OFF position.
2. Ensure that the Inverter DC Isolator(s) are in the OFF position.
3. Ensure that the Rooftop DC Isolator(s) are in the OFF position.
4. Using a multimeter set on the DC voltage scale, measure between the string positive and negative terminals at the module side of the string Rooftop DC Isolator and compare the value obtained with the table below. For SolarEdge systems see note below.

Note (SolarEdge systems only): Each power optimizer in a string will output a voltage of 1 V ($\pm 0.1 \text{ V}$). For example: 9 power optimizers connected in a string should output a voltage of 9 V ($\pm 0.9 \text{ V}$).

5. Repeat for each string.

Indicative String V_{oc} @ NOCT*											
Number of modules in string	4	5	6	7	8	9	10	11	12	13	14
REC280TP modules	157	196	236	275	314	353	392	432	471	510	549

* Values measured at normal operating cell temperature (NOCT) defined as: irradiance of 800 W/m², Spectrum AM 1.5, wind speed 1 m/s and ambient temperature 20°C. Variations from NOCT values will affect actual V_{oc} and should be allowed for.

The open-circuit voltage (V_{oc}) of every string must be measured before switching on the inverter and must be within 5% of the calculated value. If readings are outside the calculated value by more than $\pm 5\%$, then

connections must be verified for polarity, continuity and possible faults and repaired where necessary. Once verification has been satisfactorily completed, strings may then be connected to the inverter.

SOLAR ISOLATION DEVICE(S) TEST – ROOFTOP DC ISOLATOR(S)

This test is performed to ensure the Rooftop DC Isolator(s) are isolating the string(s) from the inverter when in the OFF position.

1. Ensure that the Inverter AC Isolator(s) are in the OFF position.
2. Switch all string DC Isolators to the ON position (Rooftop and Inverter DC Isolators).
3. Ensure that the PV system is operating under irradiance conditions greater than 500 W/m².
4. Switch the string Rooftop DC Isolator to the OFF position.
5. Disconnect string positive and negative DC plug connectors from inverter.
6. Using a multimeter set on the DC voltage scale, connect multimeter leads between the disconnected string plugs. Ensure leads are firmly connected. If a DC voltage is present, the Rooftop DC Isolator or system wiring is faulty and will require replacing or repairing.

Note (SolarEdge systems only): Each power optimizer in a string will output a voltage of 1 V (± 0.1 V). For example: 9 power optimizers connected in a string should output a voltage of 9 V (± 0.9 V).

7. Switch the string Rooftop DC Isolator to the ON position. If a DC voltage is not present, the Rooftop DC Isolator or system wiring is faulty and will require replacing or repairing.
8. Switch the string Rooftop DC Isolator to the OFF position.
9. Reconnect string positive and negative DC plug connectors to inverter.
10. Repeat for each string.

SOLAR ISOLATION DEVICE(S) TEST – INVERTER DC ISOLATOR(S)

This test is performed to ensure the Inverter DC Isolator(s) are isolating the string(s) from the inverter when in the OFF position.

1. Ensure that the Inverter AC Isolator(s) is in the OFF position.
2. Switch all string DC Isolators to the ON position (Rooftop and Inverter DC Isolators).
3. Ensure that the PV system is operating under irradiance conditions greater than 500 W/m².
4. Switch the string Inverter DC Isolator to the OFF position.
5. Disconnect string positive and negative DC plug connectors from inverter.
6. Using a multimeter set on the DC voltage scale, connect multimeter leads between the disconnected string plugs. Ensure leads are firmly connected. If a DC voltage is present, the Inverter DC Isolator or system wiring is faulty and will require replacing or repairing.

Note (SolarEdge systems only): Each power optimizer in a string will output a voltage of 1 V (± 0.1 V). For example: 9 power optimizers connected in a string should output a voltage of 9 V (± 0.9 V).

7. Switch the string Inverter DC Isolator to the ON position. If a DC voltage is not present, the Inverter DC Isolator or system wiring is faulty and will require replacing or repairing.
8. Switch the string Inverter DC Isolator to the OFF position.
9. Reconnect string positive and negative DC plug connectors to inverter.
10. Repeat for each string.

INSULATION RESISTANCE TEST

This test is performed to verify the insulation resistance between the positive DC string wiring and earth and the negative DC string wiring and earth are both greater than or equal to 1 Megaohm (1 MΩ) as required by AS/NZS 5033:2014 Clause D4.

An insulation tester capable of applying test voltages of 500V and 1000V is required to perform this test.

⚠ Warning: Live voltages of up to 600 VDC will be present during this test. Wear personal protective equipment to prevent the risk of electric shock and treat DC string wiring as if it were live at all times.

⚠ Warning: Do not permit any person to touch any part of the array whilst the insulation test is being performed.

1. Ensure that the Inverter AC Isolator is in the OFF position.
2. Switch the Rooftop DC Isolator(s) to the ON position.
3. Switch the Inverter DC Isolator(s) to the OFF position.
4. Disconnect string positive and negative DC plug connectors from inverter.
5. Connect the insulation tester leads between the disconnected positive string plug and earth. Ensure test leads are firmly fixed in position.
6. Select the appropriate test voltage on the insulation tester according to the number of modules in the string (500 V for a string of 6-10 modules; 1000 V for a string of 11-14 modules).
7. Switch the Inverter DC Isolator to the ON position.

⚠ Warning: The positive and negative string wiring is now live and will have up to 600 VDC present.

8. Activate insulation tester. The resistance measured must be greater than or equal to 1 MΩ.
9. Switch the Inverter DC Isolator to the OFF position.
10. Connect insulation tester leads between the disconnected negative string plug and earth. Ensure test leads are firmly fixed in position.
11. Switch the Inverter DC Isolator to the ON position.

⚠ Warning: The positive and negative string wiring is now live and will have up to 600 VDC present.

12. Activate insulation tester. The resistance measured must be greater than or equal to 1 MΩ.
13. Switch the Inverter DC Isolator to the OFF position.
14. Reconnect string positive and negative DC connectors to the inverter.
15. For the Two String Configuration, repeat this procedure for the second string.

VERIFICATION OF INVERTER WIRING

This verification is performed to ensure the inverter is correctly and safely wired. Check the Positive and Negative connectors are fully engaged at the Inverter and any unused inputs have connectors with sealing plugs installed.

INVERTER COMMISSIONING

⚠ Warning: Do not turn on the inverter until all of the previous commission procedure tests/checks have been satisfactorily completed.

Turn on the PV system (refer to “To Turn PV System On” in the Solahart PV Systems Owner’s Guide) then commission the inverter according to the commissioning procedure described in the relevant inverter installation guide for the model inverter installed.

For Power-One/ABB inverters the start voltage must be correctly set based on the type and size of array to allow the system to perform correctly. To set the start voltage refer to “Power-One/ABB Inverter Start Voltage” on page 47.

For SMA inverters that do not have display screens, commissioning is performed by directly connecting a smart device to the Inverter Built-in WLAN Web User Interface (UI). A laptop, tablet or smartphone is required for commissioning the inverter. For details refer to “SMA Inverter Commissioning through Web UI” on page 45.

SMA INVERTER COMMISSIONING USING WEB UI

The following inverter models are commissioned using the Web UI:

- SB 1.5/2.5-1 VL-40
- SB3.0/4.0/5.0-1AV-40

Prepare the inverter for commissioning

1. Ensure all circuit breakers, inverter and cables are correctly rated, mounted and installed. (PV Array DC Isolator, DC Load-break switch of inverter to Position I).
2. Switch on the AC Circuit Breaker.

Connecting via WLAN

1. Ensure a Smart device (e.g. computer, tablet pc or smartphone) and the appropriate web browser (see SMA Operating Manual) is available.
2. Connect to Wi-Fi network of the inverter named **SMA[serial number]**.
3. Enter the WLAN Password:
 - a) Within the first 10 operating hours, the WLAN password is **SMA12345**
 - b) After the first 10 hours of operation, the WLAN password is the WPA2-PSK sequence, located on the rating label on the side of the inverter (also found on the rear side of SMA Quick Reference Guide included in delivery)

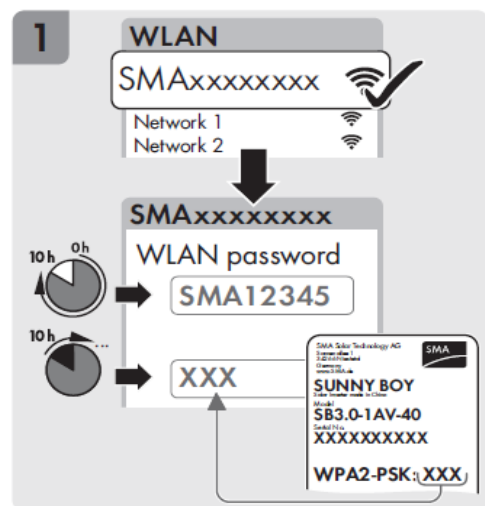

Logging into the User Interface

1. Enter the IP Address in an appropriate web browser:
 - For SB3.0/4.0/5.0-1AV-40 enter **192.168.12.3**
 - For SB1.5/2.5-1VL-40 enter **192.168.100.1**
2. In the drop-down list **Language**, select the desired language.
3. In the **User Group** drop-down list, select the entry **Installer**.
4. In the **New Password** field, enter a new desired password, repeat the password and click **Login**.

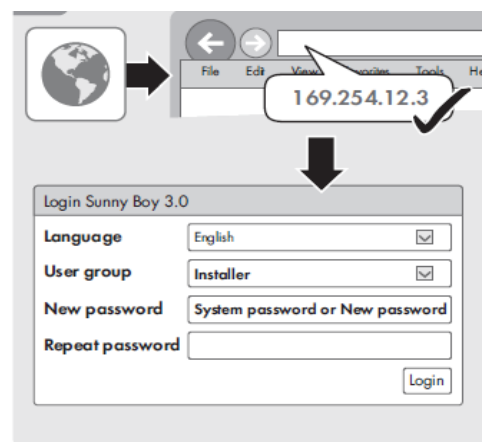

Configuring Inverter Settings

1. Once logged in, select '**Configuration with Installation assistant**'.
2. If internet is available, configure the network connection:
 - a. Choose appropriate connection type
 - Ethernet
 - WLAN
 - b. Type in network password as required.
 - c. Select '**Save and Next**'.
3. Select correct **Time Zone** based on installation location. Select '**Save and Next**'.
4. Select Country Standard '**AS4777.2_2015**'. Select '**Save and Next**'.
5. Set Feed in Management parameters if applicable. Default parameters can be used if no power limitation is required. Select '**Save and Next**'.
6. The configuration summary page is displayed. Check all parameter settings to ensure they are entered correctly. Select '**Continue**' to finish the configuration process.

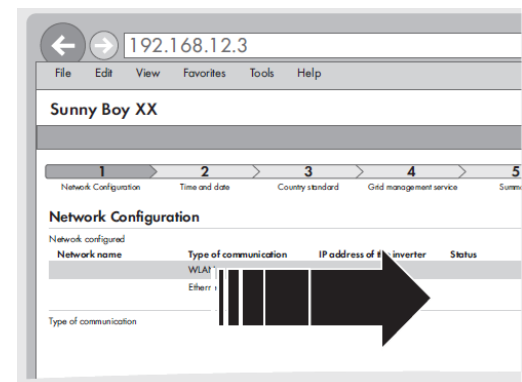
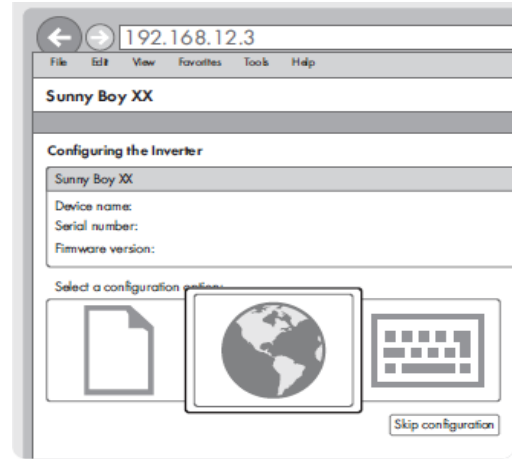

Final Commissioning Steps

1. The inverter will undergo a countdown of 60 seconds. Once the inverter connects to the grid, the green light should stop flashing and glow steadily. This indicates that the system is operating normally.
2. Register the PV System if the inverter is connected to internet:
 - a. Go to <https://www.sunnyportal.com>
 - b. Select "**Plant Setup Assistant**" and follow the wizard to complete registration

Provide Sunny Portal login details to the customer.

POWER-ONE/ABB INVERTER START VOLTAGE

The start voltage (VStart) is the DC voltage at which the inverter will begin to transform DC to AC.

Inverter Model PVI-3.0 / 4.2 / 5000-TL-OUTD

Each zone input (IN1 and IN2) of this inverter has a nominal factory preset start voltage of $200V \pm 2V$.

For single string configurations with fewer than 7 modules, the start voltage for the connected zone input (IN1 or IN2) must be adjusted in order for the system to function correctly and efficiently. The start voltage of the unused zone input may be left set to the factory preset voltage.

For dual string configurations, and any string with fewer than 7 modules, the start voltage for the connected zone input (IN1 and/or IN2) must be adjusted in order for the system to function correctly and efficiently.

The display on this inverter allows the start voltage to be checked and altered as follows:

1. Press and release the '**ESC**' button.
2. Press and release the down '↓' button until 'Settings' is displayed on the screen.
3. Press and release the '**Enter**' button. 'Password 0000' will be displayed on the screen.
4. Enter password '0000' using the arrow keys.
5. Press and release the down '↓' button until 'VStart' is displayed on the screen.
6. Press and release the '**Enter**' button. 'VStart1 VStart2' will be displayed on the screen with an arrow adjacent to VStart 1.
7. Press and release the '**Enter**' button to select 'VStart1'. 'Set VStart1' and the current start voltage setting for the string connected to IN1 will be displayed on the screen.
8. Press and release the up '↑' or down '↓' buttons to change the start voltage to the desired setting.
 - a. If the string connected to IN1 has 5 modules, set the voltage to 140 V.
 - b. If the string connected to IN1 has 6 modules, set the voltage to 170 V.
 - c. If the string connected to IN1 has 7 or more modules, set the voltage to 200 V.
9. Press and release the '**Enter**' button to accept the setting.
10. Press and release the '**ESC**' button once to return to the menu displaying 'VStart1 VStart2'.
11. Press and release the down '↓' button. The arrow on the screen will move from 'VStart1' to 'VStart2'.
12. Press and release the '**Enter**' button to select 'VStart2'. 'Set VStart2' and the current start voltage setting for the string connected to IN2 will be displayed on the screen.
13. Press and release the up '↑' or down '↓' buttons to change the voltage to the desired setting.
 - a. If the string connected to IN2 has 5 modules, set the voltage to 140 V.
 - b. If the string connected to IN2 has 6 modules, set the voltage to 170 V.
 - c. If the string connected to IN2 has 7 or more modules, set the voltage to 200 V.
14. Press and release the '**Enter**' button to accept the setting.
15. Press and release the '**ESC**' button until you exit 'Settings' mode.

VERIFICATION OF SYSTEM OPERATION

This step is performed to verify the PV system is operating correctly.

1. Ensure all DC Isolators are in the ON position (Rooftop and Inverter DC Isolators).
2. Ensure the AC Isolator is in the ON position.
3. Ensure the PV system is operating under irradiance conditions greater than 500 W/m².

Note (SolarEdge systems only): Follow system verification procedure outlined in the inverter installation manual supplied with the inverter. Skip Step 4 below.

4. After waiting for the inverter to connect to the grid, record the 'Input Voltage' for each string which will be alternately displayed on the inverter LCD screen. Check this 'Input Voltage' is within ±5% of the value for the number of modules in each string, according to the following table:

Indicative String V_{mp} @ NOCT											
Number of modules in string	4	5	6	7	8	9	10	11	12	13	14
REC280TP modules	128	160	192	224	256	288	319	351	383	415	447

* Values measured at normal operating cell temperature (NOCT) defined as: irradiance of 800 W/m², Spectrum AM 1.5, wind speed 1 m/s and ambient temperature 20°C. Variations from NOCT values will affect actual V_{mp} and should be allowed for.

EARTH FAULT PROTECTION TEST

This step is performed to verify that the earth fault protection system and earth fault alarm is operating correctly.

5. Set the PV system in normal operation mode.
6. Using a variable resistor load, simulate a high impedance earth fault on the positive conductor of the PV array cable.
7. Decrease the resistance gradually until the earth fault protection device detects the fault. Record the earth fault current level or resistance, or both, that triggers the earth fault protection device.
8. The measured values should comply with the requirements of IEC 62109 for earth fault detection.

The measured earth fault current shall not exceed 3.5 mA AC or 10 mA DC (IEC 62109-1:2010 Clause 7.3.5.3.1)

9. Check that the earth fault alarm operation complies with AS/NZS 5033 earth fault alarm requirements.
 - a. If applicable, an email should be received by the PV system owner and/or installer and/or dealer.
 - b. If applicable, an audio and/or visual alarm should operate
 - c. Inverter display should indicate the presence of an earth fault
10. Repeat steps (1) to (5) for the negative conductor of the PV array cable in unearthed PV arrays.
11. Repeat steps (1) to (6) for each PV array connected to the inverter.

ENGINEERING CERTIFICATION



innovation in design and construction

Gamcorp (Melbourne) Pty Ltd A.C.N 141 076 904 A.B.N 73 015 060 240

www.gamcorp.com.au melbourne@gamcorp.com.au

1/19 Anthony Drive, Mount Waverley VIC 3149. Tel: 03 9803 9533 Fax: 03 9802 9125



Our Ref: 23939

18 February 2013

Clenergy Australia
18/20 Duerdin Street
Clayton North VIC 3168

Array Frame Engineering Certificate

Installation of PV-ezRack[®] SolarRoof on Tin and Tile Roof

Gamcorp (Melbourne) Pty Ltd, being Structural Engineers within the meaning of Australian Building Regulations, have carried out a structural design check of PV-ezRack[®] SolarRoof installation within Australia. The design check has been based on the information in the *PV-ezRack SolarRoof_Code Compliant planning and Installation_Guide AV_V2.2* and schematic drawings of the system components by Clenergy (Xiamen) Technology Co. Ltd., provided by Clenergy Australia.

We find the Installation of PV-ezRack[®] SolarRoof on tin and tile roof to be structurally sufficient for Australian use based on the following conditions:

- Wind Loads to AS/NZ1170.2:2011 Admt 2-2012
- Wind Region A, B, C, D
- Wind Terrain Category 2 & 3
- Wind average recurrence interval of 100 years
- Maximum Building height 20 m
- Max. Solar Panel Dimensions 2000x1000

Refer to attached summary table for interface spacing.

Construction is to be carried out strictly in accordance with the manufacturers instructions. This work was designed in accordance with the provisions of Australian Building Regulations and in accordance with sound, widely accepted engineering principles.

Yours faithfully,
Gamcorp (Melbourne) Pty Ltd

A handwritten signature in blue ink, appearing to read 'Martin Gamble'.

Martin Gamble
Managing Director
MAICD

A handwritten signature in blue ink, appearing to read 'Milan Bjelobrk'.

Milan Bjelobrk
MIEAust, CEng, NPER 2210984,
RPEQ 12090, RBP EC-38461, NT BPB 139671ES



innovation in design and construction

Gamcorp (Melbourne) Pty Ltd A.C.N 141 076 904 A.B.N 73 015 060 240

www.gamcorp.com.au melbourne@gamcorp.com.au

1/19 Anthony Drive, Mount Waverley VIC 3149. Tel: 03 9803 9533 Fax: 03 9802 9125



Our Ref: 23939

18 February 2013

Clenergy Australia
18/20 Duerdin Street
Clayton North VIC 3168

Array Frame Engineering Certificate

Installation of PV-ezRack[®] SolarRoof Adjustable Tilt Legs

Gamcorp (Melbourne) Pty Ltd, being Structural Engineers within the meaning of Australian Building Regulations, have carried out a structural design check of PV-ezRack[®] SolarRoof Adjustable Tilt Legs installation within Australia. The design check has been based on the information in the PV-ezRack SolarRoof Adjustable Tilt Legs_Code Compliant Installation Guide_AU_V3.2 and schematic drawings of the system components by Clenergy (Xiamen) Technology Co. Ltd, provided by Clenergy Australia.

We find the Installation of PV-ezRack[®] SolarRoof Adjustable Tilt Legs installation to be structurally sufficient for Australian use based on the following conditions:

- Wind Loads to AS/NZ1170.2:2011 Admt 2-2012
- Wind Region A, B, C, D
- Wind Terrain Category 2 & 3
- Wind average recurrence interval of 100 years
- Maximum Building height 20 m
- Max. Solar Panel Dimensions 2000x1000

Refer to attached summary table for interface spacing.

Construction is to be carried out strictly in accordance with the manufacturers instructions. This work was designed in accordance with the provisions of Australian Building Regulations and in accordance with sound, widely accepted engineering principles.

Yours faithfully,
Gamcorp (Melbourne) Pty Ltd

Martin Gamble
Managing Director
MAICD

Milan Bjelobr
MIEAust, CPEng, NPER 2210984,
RPEQ 12090, RBP EC-38461, NT BPB 139671ES

SOLAHART PV SYSTEM WARRANTY - AUSTRALIA ONLY

IMPORTANT NOTE: This Limited Warranty covers a range of systems, products and components. This Warranty only applies in respect of the specific items you have purchased and which are delivered to you in conjunction with this hard copy Warranty document.

Your new PV System comprises a PV Module, an Inverter, a racking system and balance of system components (together the **PV System**). Alternatively, you may add components sourced from Solahart to your existing PV System and associated products.

The PV System and any other components supplied by Solahart (collectively, the 'Products') are covered by a warranty given by Solahart Industries Pty Ltd ABN 45 064 945 848 of 1 Alan Street, Rydalmere NSW 2116 (**Solahart**). The terms of your warranty are set out below. This warranty consists of a number of parts (not all of which will apply, depending on the Products you have purchased):

- A. The specific warranty terms for Modules supplied by Solahart;
- B. The specific warranty terms for Inverters – SMA and ABB;
- C. The specific warranty terms for SolarEdge Inverters and associated SolarEdge products;
- D. The specific warranty terms for the racking system;
- E. The specific warranty terms for the balance of the system;
- F. The specific warranty terms for the labour; and
- G. General terms which apply to all of the above.

This Limited Warranty is valid in Australia for all Products sold after 17 March 2016. If a subsequent version of this warranty is published, the terms of that warranty will apply to Products manufactured after the date specified in the subsequent version.

Solahart issues the following voluntary warranty to:

- 12. The end-user who purchased the System in Australia and put the System into use for the first time (the 'Original End-User'); and
- 13. In the case of SolarEdge Products only, any owner of the Product subsequent to the Original End-User who provides proof of title transfer, provided that the Product has never been relocated from its original installation location without the express written consent of Solahart.

This warranty is in addition to any rights and remedies that you may have under the Australian Consumer Law.

Solahart offers national service through its Dealer network. Solahart will repair or replace parts subject to the terms of this Limited Warranty. Solahart, in addition can provide preventative maintenance and advice on the operation of the PV System. You can contact Solahart on 1800 638 011 to arrange a service call or to find out details about this warranty.

Notification of a claim under this Limited Warranty must be given without undue delay after detection of the defect and prior to the expiration of the applicable Warranty Period and in accordance with the procedure set out below.

PART A - MODULES

Warranty coverage for the Module

Subject to the terms and conditions of this Limited Warranty, Solahart warrants that the Modules:

- 14. Are free from defects in material and workmanship for a period of (10) years after the date of installation of the Module (the 'Module Warranty Period') if installed and used in accordance with the installation instructions set out in the Solahart Owner's Guide and Installation Instructions – PV Systems which accompanies the Module, and with all relevant statutory and local requirements in the State or Territory in which the Module is installed.

15. Will remain safe and operational if cable and connector plugs are installed professionally and are not permanently positioned in water; provided however, that damage to the cable caused by abrasion on a rough surface due to insufficient fixing or to unprotected running of the cable over sharp edges is excluded. Damage caused by animals is also excluded.
16. Will not experience freezing up of the aluminium frames if installed correctly.

The outer appearance of the Module, including scratches, stains, rust, mould, discoloration and other signs of normal wear and tear, which occurred after delivery or installation, do not constitute defects, provided the functionality of the Module is not affected. Glass breakage constitutes a defect only if not caused by any external influence.

If a defect (as described above) occurs during the Module Warranty Period materially affecting the functionality of the Module, Solahart will, at its sole option:

17. Repair the defective Module;
18. Replace the Module with an equivalent product; or
19. Refund the original purchase price for the Module as determined by Solahart.

Warranty Terms, Limitations and Exclusions

This Limited Warranty applies to the original Module and to any approved replacement parts and is not transferable by the Original End-User, except to the subsequent owner of the property at which the original PV System was installed and remains installed, provided that this PV System has not been altered in any way or moved from the structure or property at which it was originally installed.

There are many factors that affect the output of your Module. Solahart does not warrant a specific power output for your Modules. All modules degrade over time and power output is subject to many variables including the age of the Module.

PART B – INVERTERS – SMA AND ABB

Warranty coverage for SMA and ABB Inverters

Solahart warrants that the Inverter, when located at its original installation, will operate in accordance with its specifications in the Solahart's Owner's Guide and Installation Instructions for a period of five (5) years from the date of installation of the inverter. If the Inverter fails to operate in accordance with its specifications and this materially affects the usability of the Inverter, Solahart will, at its sole option:

20. Repair the Inverter;
21. Provide a replacement Inverter swapped; or
22. Refund the original purchase price for the Inverter as determined by Solahart.

PART C – INVERTERS AND ASSOCIATED COMPONENTS – SOLAREEDGE

(In this Part D, a reference to "Products" is to the SolarEdge Products as described below).

Warranty coverage for SolarEdge Inverter

Subject to the terms and conditions of this Limited Warranty, Solahart provides a warranty against defects in workmanship and materials in relation to the SolarEdge Inverter, when located at its original installation, for a period of ten (10) years commencing on the earlier of:

23. 4 months from the date the Inverter is shipped from the manufacturer; and
24. The date of installation of the Inverter.

Warranty coverage for StorEdge Interface

Subject to the terms and conditions of this Limited Warranty, Solahart provides a warranty against defects in workmanship and materials in relation to the StorEdge Interface for a period of ten (10) years commencing on the earlier of:

25. 4 months from the date the Interface is shipped from the manufacturer; and
26. The date of installation of the Interface.

Warranty coverage for Power Optimizers

Subject to the terms and conditions of this Limited Warranty, Solahart provides a warranty against defects in workmanship and materials in relation to the Power Optimizers for a period of ten (10) years commencing on the earlier of:

27. 4 months from the date the Power Optimizers are shipped from the manufacturer; and
28. The date of installation of the Power Optimizers.

For all Power Optimizers with a part number ending in C, this warranty does not apply to the input connector.

Warranty coverage for Power Meter

Subject to the terms and conditions of this Limited Warranty, Solahart provides a warranty against defects in workmanship and materials in relation to the Power Meter for a period of five (5) years commencing on the earlier of:

29. 4 months from the date the Power Meter is shipped from the manufacturer; and
30. The date of installation of the Power Meter.

Remedies

If Solahart determines that a reported defect in relation to a Product is eligible for coverage under this Limited Warranty (including retention capacity), Solahart will, at its sole option:

31. Repair the defective Product;
32. Issue a credit note for the defective Product in an amount up to its actual value at the time buyer notifies Solahart of the defect, as determined by Solahart, for use toward the purchase of a new Product; or
33. Provide the buyer with replacement units for the Product.

Exclusions

The Limited Warranty does not apply to components which are separate from the Products, ancillary equipment and consumables, such as, for example, cables, fuses, wires and connectors.

Beneficiary of Limited Warranty

The Limited Warranty only applies to the buyer who purchased the Products from Solahart, for use in accordance with their intended purpose ('Original Buyer'). The Limited Warranty may be transferred from the Original Buyer to any assignee, and will remain in effect for the time period remaining under the above Warranty Periods, provided that the Products are not moved outside their original country of installation and any reinstallation is done in accordance with the installation directions and use guidelines accompanying the Products.

PART D – THE RACKING SYSTEM**Warranty coverage for the Racking System**

Solahart warrants that the racking system supplied with the PV System shall be free from defects in material and workmanship for a period of five (5) years from the date of installation.

This Warranty shall be void if installation of the racking system is not performed in accordance with the Owner's Guide and Installation Instructions, or if the racking system has been modified, repaired, or reworked in a manner not previously authorized by Solahart in writing. If within the specified Warranty period the racking system shall be reasonably proven to be defective, then Solahart shall repair or replace the defective component(s) at Solahart's sole discretion. Such repair or replacement shall completely satisfy and discharge all of Solahart's liability with respect to this Limited Warranty.

PART E - BALANCE OF THE SYSTEM**Warranty coverage for the balance of the system**

The balance of the PV System (**BOS**) consists of PV module cabling, circuit breakers, isolators, enclosures and labels. Solahart warrants that the BOS supplied by it will operate in accordance with its specifications in the Owner's Guide and Installation Instructions for a period of five (5) years from the date of installation of the BOS. If the BOS fails to operate in accordance with its specifications and this materially affects the usability of the BOS, Solahart will, at its sole option, repair or replace the defective component.

PART F - LABOUR WARRANTY

Warranty coverage for labour – PV System

In addition to the above coverage, Solahart provides you with 5 years of coverage, from the date of installation, for all labour costs involved with inspection by Solahart, removal or installation of warranted parts or components by Solahart of your PV System. Other than this 5 years coverage, this Warranty does not cover, nor will Solahart reimburse, any on-site labor or other costs incurred in connection with the inspection, de-installation or removal of defective parts or components, or the re-installation of replaced or repaired parts or components for your PV System.

Warranty coverage for labour - SolarEdge Products

If Solahart determines that a reported defect in relation to a SolarEdge Product is eligible for coverage under this Limited Warranty and Solahart decides to repair the Product or part(s), warranty coverage includes labour and material costs necessarily incurred to correct the Product defect; and where Solahart decides to replace the Product or part(s) to which the Limited Warranty applies, warranty coverage includes the cost of the replacement of the Product or part(s). All other costs will be borne by you.

PART G - GENERAL TERMS

Back-up if sole or dominant power supply

If the PV System is to be the sole or dominant power supply for your business or application, you should ensure that you have back up redundancy if the PV System were to become inoperable for any reason. We suggest that you seek advice from your electrician or qualified professional about your needs and build backup redundancy into your electricity supply system.

Application of this warranty

This warranty requires the Products to be installed according to the latest safety, installation and operation instructions provided by Solahart and with all relevant statutory and local requirements in the State or Territory in which the Products are installed, and does not apply to defects, damage, malfunction, power output or service failures which have been caused by:

34. Storage, installation, commissioning, repair, modifications, alterations, attachments or movement to or of the Product or otherwise without the prior written consent of Solahart;
35. Abuse, misuse or abnormal use, accident, negligent acts, power failures or surges, force majeure events including but not limited to lightning, fire, flood, hail, extreme cold weather, or any other natural disaster, any other force majeure event, pest damage, accidental breakage, actions of third parties, and any other events or accidents outside Solahart's control and/or not arising under normal operating conditions;
36. Operating the Product in an unintended environment or under incorrect safety or protection conditions;
37. Failure to install, operate and/or maintain the Product in accordance with the applicable Solahart Owner's Guide and Installation Instructions;
38. Transport damage;
39. Wear and tear from adverse conditions including corrosive atmospheric conditions e.g. salt, ocean spray, dust storm or other weather damage;
40. Cosmetic defects;
41. Any improper attachment, installation or application of the Product, and in respect of the PV System, any insufficient framing if the PV System is a frameless module;
42. Any attempt to extend or reduce the life of the Product, whether by physical means, programming or otherwise, without the prior written consent of Solahart;
43. Removal and reinstallation at a location other than the original installation location, without the prior written consent of Solahart;
44. Insufficient ventilation of the Product;
45. Failure to observe the applicable safety regulations; or any factor identified in the applicable Solahart Owner's Guide and Installation Instructions; or
46. Ignoring safety warnings and instructions contained in all documents relevant to the applicable Product.

If your claim relates to a failure to operate in accordance with the Solahart Owner's Guide and Installation Instructions as a result of one of the factors listed above, Solahart may charge you at its standard rates for its time and materials related to your claim.

Without limiting the above exclusions:

47. In relation to SolarEdge Products, the Warranty does not cover: (a) Products which are installed or operated not in strict accordance with the accompanying instruction documentation, including without limitation, not ensuring sufficient ventilation for the Product as described in the applicable installation guide; (b) Products which are opened, modified or disassembled in any way without Solahart's prior written consent; (c) Products which are used in combination with equipment, items or materials not permitted in the instruction documentation or in violation of local codes and standards; or (d) cosmetic or superficial defects, dents, marks or scratches which do not influence the proper functioning of the Products.

Location and positioning

Where the Product is installed outside the boundaries of a metropolitan area (as defined by Solahart) or further than 25 km from a regional Solahart Dealer, the cost of transport, insurance and travelling costs to the nearest Solahart Dealer shall be the owner's responsibility. Where the Product is installed in a position that does not allow safe, ready access, the cost of accessing the site safely, including the cost of additional materials handling and/or safety equipment, shall be the owner's responsibility.

Replacements

Solahart may use new, used, remanufactured or refurbished parts or products when repairing or replacing any Product under this Limited Warranty. Any exchanged or replaced parts or Products will become the property of Solahart. Goods presented for repair may be replaced by refurbished goods of the same type rather than being repaired.

If the Product is repaired or replaced under this Warranty, the remainder of the applicable Warranty Period will apply to the repaired or replaced Product and the repaired or replaced Product or parts will not carry a new Solahart Warranty. The Warranty Periods set out above will not be extended in any way in the event of a replacement or repair of a Product, but this does not affect any rights you may have under the Australian Consumer Law in relation to the replaced or repaired Product (see the section below entitled "The Australian Consumer Law" for further details).

Limitation of this warranty

This Limited Warranty is provided voluntarily and free of charge and does not constitute an independent guarantee promise. Therefore, if any defect materially affects the functionality of any Product, the remedies under this Warranty are limited exclusively to the remedies set out above in the warranty cases specified herein.

Subject to any statutory provisions to the contrary, Solahart assumes no warranties, express or implied, written or oral, other than the warranties made herein and specifically disclaims all other warranties, merchantability or fitness for a particular purpose and Solahart excludes all liabilities for any special, incidental, indirect, consequential or punitive damages arising from or in connection with the use or loss of use of the Product to perform as warranted, regardless of the form of action and regardless of whether a party has been informed of or otherwise might have anticipated the possibility of such damages; including but not limited to damages for loss of power, lost profits or savings nor expenses arising from third-party claims. This does not apply to the extent Solahart is liable under applicable mandatory laws.

If you require a call out and we find that the fault is not covered by Solahart's warranty, you are responsible for our standard call out charge. If you wish to have the relevant component repaired or replaced by Solahart that service will be at your cost.

Entitlement to claim under this warranty

To be entitled to make a claim under this warranty you need to:

48. Provide proof of purchase documentation and be the owner of the Product or have the consent of the owner to act on their behalf.
49. Contact your Solahart dealer without undue delay after detection of the defect and, in any event, within the applicable Warranty Period.

You are not entitled to make a claim under this warranty if the relevant Product:

50. Does not have its original serial numbers and type plate or numbers are illegible; or

51. Is not installed in Australia.

Warranty claim procedure

If you wish to make a claim under this warranty, you need to:

52. Contact your Solahart dealer, provide proof of purchase (and in the case of a SolarEdge Product, any subsequent transfers of ownership of the Product) and owner's details, address of the Product, a contact number and date of installation of the Product, the serial number of the Product, and a description of the alleged defect(s).
53. Solahart will arrange for the Product to be tested and assessed. Solahart will inform you whether this will occur on-site or whether the Product must be sent elsewhere for testing and assessment.
54. If Solahart determines in its sole discretion that you have a valid warranty claim, Solahart will organise for the repair or replacement of the Product or any component in accordance with this warranty.

Any expenses incurred in the making of a claim under this Warranty will be borne by you.

Before any SolarEdge Product is returned to Solahart, an RMA (Return Merchandise Authorization) number is required and will be provided to you by Solahart along with any additional instructions.

The Australian Consumer Law

Our goods come with guarantees that cannot be excluded under the Australian Consumer Law. You are entitled to a replacement or refund for a major failure and compensation for any other reasonably foreseeable loss or damage. You are also entitled to have the goods repaired or replaced if the goods fail to be of acceptable quality and the failure does not amount to a major failure.

Solahart Industries Pty Ltd (A.B.N. 45064945848)
Registered Office
1 Alan Street (PO Box 7508, Silverwater, 2128)
Rydalmere New South Wales 2116
Australia

For SERVICE Telephone - **1800 638 011**
or your nearest Solahart Dealer
For Sales Telephone - **1300 769 475**
or your nearest Solahart Dealer
www.solahart.com.au

Revision Date: 2017 March

122233D