



Installation Instructions SUPERCHARGER

'90-'93 Mazda Miata

Part# 999-000, 999-005, 999-010, 999-015

440 Rutherford St. P.O. Box 847 Goleta, CA 93117
1-888-888-4079 • FAX 805-692-2523 • www.jacksonracing.com

INSTALLATION TIME IN AS LITTLE AS 4 HOURS FOR EXPERIENCED MECHANICS, AROUND 5 TO 6 HOURS FOR "OCCASIONAL" MECHANICS.

TOOLS REQUIRED: 3/8" Drive Socket set w/ 17mm, 14mm, 13mm, 12mm, 10mm & 8mm sockets; Deep sockets (14mm or 9/16", 10mm); Phillips and Standard screwdriver, 10mm, 12mm, and 17mm open end wrench; 5mm Allen wrench with a 3/8" drive; paper clip; a box to store your OLD PARTS in. A 1/4" drive socket set will be useful with some of the tight working areas. A timing light will be needed to set the ignition timing.

A NOTE ON ADDING A SUPERCHARGER TO YOUR MIATA

This system has been carefully designed with attention to every detail utilizing over 1000 hours of engineering and testing. Each component of this system has been carefully designed to match the quality of the automobile you purchased from Mazda. The only added maintenance item for your Miata will be an occasional belt tension check for the Supercharger drive. As for your engine's life, a Miata engine in good condition will see little reduction in useful life with the addition of this system. However, it is your responsibility to insure that your engine is in good condition before you install this system. Putting boost on a tired engine will lead to catastrophe. If your car has under 80,000 miles on it and has had the oil changed

regularly (every 3000 miles or so), you should have no trouble. If in doubt, check your engine's compression. You should have at least 135psi of compression in each cylinder with no more than a 10% variance between any two cylinders or with a 10% increase in any cylinder after a tablespoon of oil is poured in. Your cooling system should be up to par (50/50 mix of water and new coolant). Basically, if you have a good engine, it will be very happy with this supercharger.

BEFORE INSTALLING THIS SYSTEM:

- A. Drive your fuel tank empty and refill with 92 Octane major brand gasoline. If you can only find 91 Octane, see step #3 under "Adjustments" at the end of these instructions.
- B. Change your oil and filter. Use synthetic oil if possible (Mobil 1 or similar, see notes at end of instructions).
- C. Change your spark plugs if they have more than 10,000 miles on them. We suggest a set of slightly cooler plugs (#971-075) to prevent detonation. Gap these plugs at 0.038 inches. Use anti-seize compound on the threads. Splitfire spark plugs are not recommended for boosted engines due to their higher heat range.
- D. Change your fuel filter if it has more than 20,000 miles on it. This is critical.

Supercharger Installation Instructions

BEGINNING THE INSTALLATION

1.0 DISASSEMBLY

1.1 With the engine running, raise the hood and locate the main under hood fuse box by the fender well near the firewall on the passenger side of the engine compartment. Lift the main fuse box cover and locate the relay labeled "FUEL INJ". While the engine is running, remove the "FUEL INJ" relay. The engine will stop running. Turn your ignition key off. Store the "FUEL INJ" relay in a safe place until you are finished with the installation. Release the pressure in your fuel tank by removing your gas cap momentarily and then re-installing.

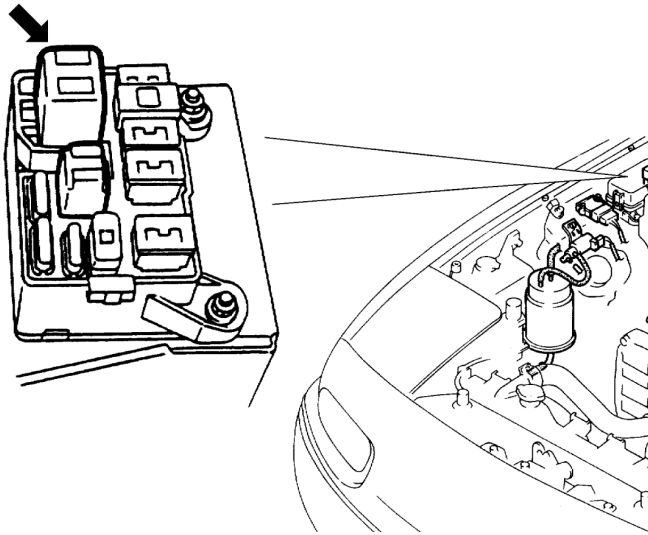

1.2 Release the airflow meter harness 7-pin connector by lifting the small wire clip that runs around the rectangular base of the connector. Remove the stock air flow meter, air filter box and intake snorkel. Remove the air flow meter from the air box. Store the air box, filter, and snorkel away. Move the air flow meter to a safe place on a worktable.

1.3 Remove the molded rubber elbow and hard plastic tube that lead from the throttle body to the airflow meter. If you have cruise control, you will also have to remove the vacuum line from the intake manifold nipple and from the points where it attaches to the hard plastic intake tube.

Remove the cruise control vacuum line from the cruise actuator as well and save it for use in step #4.4 later.

1.4 Remove the chrome crankcase vent pipe that is attached to the front of the cam cover and the rubber hose that leads into the cam cover (Figure 1.4). These can be stored away. However, find the small restrictor inside the rubber hose that ran from the cam cover to the chrome tubing. It can be felt as a lump in the straight section of the hose near the chrome tube end. Persuade it out by gently clamping the hose with a pair of pliers just behind the "lump". Save this restrictor for step #7.8. Re-install the chrome bolts that held the tubing in place. Store the chrome tube and Mazda hoses away.

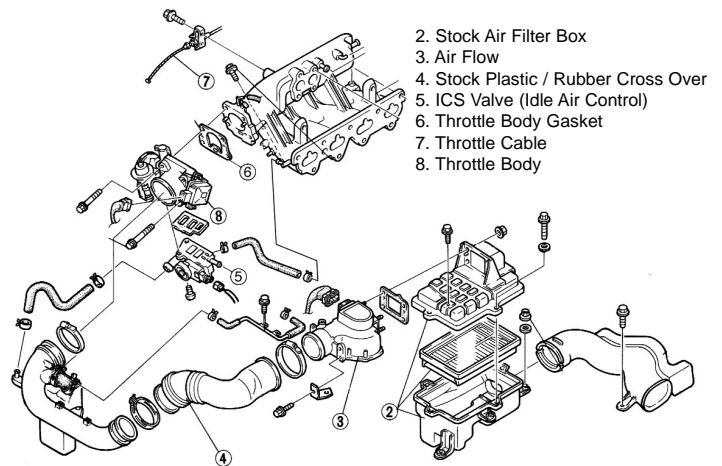

FIGURE 1.4

1.5 Locate the new engine thermostat from your supercharger kit. Installing the thermostat is as easy as it looks - it is right there on the front of the engine where the top radiator hose goes into the thermostat-housing cap. Remove the two bolts holding the cover and gently lift it off. You can leave the radiator hose attached to the cover. Place your new thermostat (spring end down) into the thermostat base. Reinstall the cover with a new gasket (provided). Make sure the old gasket material is completely off of both mating surfaces. Remember to remove the new thermostat gasket's white protective paper to expose an

Supercharger Installation Instructions

adhesive layer to assist in assembly. You can do this entire procedure without losing too much coolant. There is no need to drain your cooling system. Simply place some old newspapers on the floor to catch the pint of coolant that will spill. Make sure to top off your coolant tank once the engine is warm. If your coolant is over two years old, you must change it (see page 7-15 of your owner's manual). Your supercharged car will be using 100% of your cooling system and it must be up to the task.

Figure 1.5

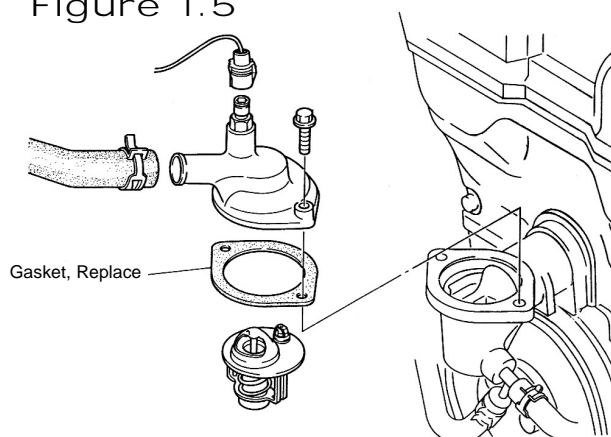

2.0 THROTTLE BODY

2.1 Remove the throttle body (FIGURE 1.4) by releasing the two electrical connectors (one has a spring wire, one has a plastic lever clip), the two small coolant hoses on either side of the lower Idle Control System (ICS) valve, and the four bolts.

TIP: THE SPRING HOSE CLAMPS FROM MAZDA ARE BEST REMOVED BY APPROACHING FROM THE SIDE WITH NEEDLE NOSE PLIERS. GRASP ALL THREE TANGS AT ONCE AND COMPRESS THEM TOGETHER. THIS IS EASIER TO DO WITH THE THROTTLE BODY ALREADY LOOSE FROM THE INTAKE MANIFOLD.

Plug the coolant hoses with a screwdriver, golf tee, or pencil to prevent the leakage of coolant (OR - keep the hose ends above the radiator cap level to prevent leakage). Release the throttle

cable from the throttle shaft spool. Release the Throttle Position Switch harness by lifting the small wire clip that runs around the rectangular base of the connector. If the throttle body gasket tears as you remove it, you will need to clean off the old gasket from both surfaces, the throttle body and the intake manifold. Carefully use a knife or the backside of a hacksaw blade to scrape the mounting surfaces clean. **DO NOT SCRATCH OR MAR THE MOUNTING SURFACES IN ANY WAY.**

2.2 Moving to a worktable, remove the idle air control (ICS) valve from the bottom of the throttle body by removing the three Phillips head screws. Use a good quality screwdriver and be careful not to strip the Phillips head screws. If you cannot loosen a screw with the screwdriver, use a small set of pliers from the side. Carefully separate the two units making sure not to tear the rubber gland gasket. The rubber gland gasket will want to stay with the Mazda throttle body carefully pick it out with a flat blade screwdriver and save it for the next step.



Figure 2.2

2.3 Take the Idle Air Manifold (dummy throttle body) from your supercharger kit and install the Mazda idle air control valve (ICS) from step 2.2 in the appropriate place. Use the rubber gland gasket from the Mazda throttle body in this position. Re-use the three Mazda Phillips screws. Use no sealant, just the rubber gasket.

Supercharger Installation Instructions

2.4 Install the Dummy Throttle Body and ICS valve back onto the intake manifold in the same position as the standard throttle body on the intake manifold. Use the 1104 sealant provided if the original gasket was not salvaged. Reconnect the coolant hoses to the idle control valve as you found them. Use hardware supplied as necessary.

2.5 Reconnect the idle control valve electrical connector.

2.6 Take the Throttle Position Switch (TPS) extension wire (3 conductor with sheathing) from your kit and use it to extend your factory TPS harness. We have provided six heat shrink butt crimp connectors to use for each wire junction you will first have to cut the three pin connector off of the end of the Mazda TPS harness. Cut at least 3 inches back from the end of the plastic connector to give yourself enough room to work with. You will be splicing in the Jackson Racing supplied extender, matching color to color. Our extender has three color-coded wires that match the colors of the Mazda harness. Strip a small section from each wire's end on the harness extender and connect it to the appropriate color wire (red conductor to red Mazda wire, etc.). Use the heat shrink butt connectors to secure each splice. Crimp with an appropriate tool or pliers. Use a heat gun or similar to shrink the butt connector's protective tubing over the crimped connector. We do not recommend the use of open flame to shrink the tubing. Wrap the entire grouping of three connectors with electrical tape at both ends to protect from moisture and dirt.

2.7 Locate the ICS blanking plate and take it over to your Mazda throttle body. You will use a thin layer of sealant between the blanking plate and the Mazda throttle body. Install this blanking plate onto your Mazda throttle body using the three Phillips head screws supplied in the kit.

3.0 BELT DRIVES

3.1 NOTE: CARS WITH POWER STEERING:

You will be re-arranging your power steering bracket components per figure 3.2. Referring to figure 3.1, remove the slot bracket and pillow block by removing bolts "A", "C", and "D". Take the flat idler pulley bracket from your kit and trial fit it to the assembly per figure 3.2. You will be moving the pillow block and bolt "D" to behind the power steering stamped steel bracket. This makes room for the flat idler pulley bracket. The upper support for the repositioned long bolt "D" comes from a relocated Mazda slot bracket. It becomes an extension bracket for bolt "D". The slot bracket is attached to the stamped steel power steering bracket using a new bolt/washer/nut assembly supplied in your kit. Make sure to point this bolt with its head nearest the nylon idler pulley and that this bolt goes through the slot. The forward hole of the repositioned slot bracket will not be used. The rearward hole is now used for the relocated "D" bolt, which will be used to tighten your drive belt. Note: The power steering pump must be in its lowest position for this procedure.

Figure 3.1

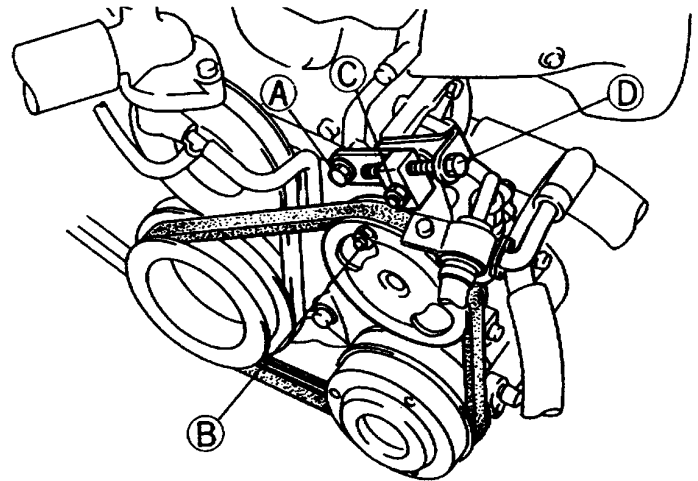

Supercharger Installation Instructions

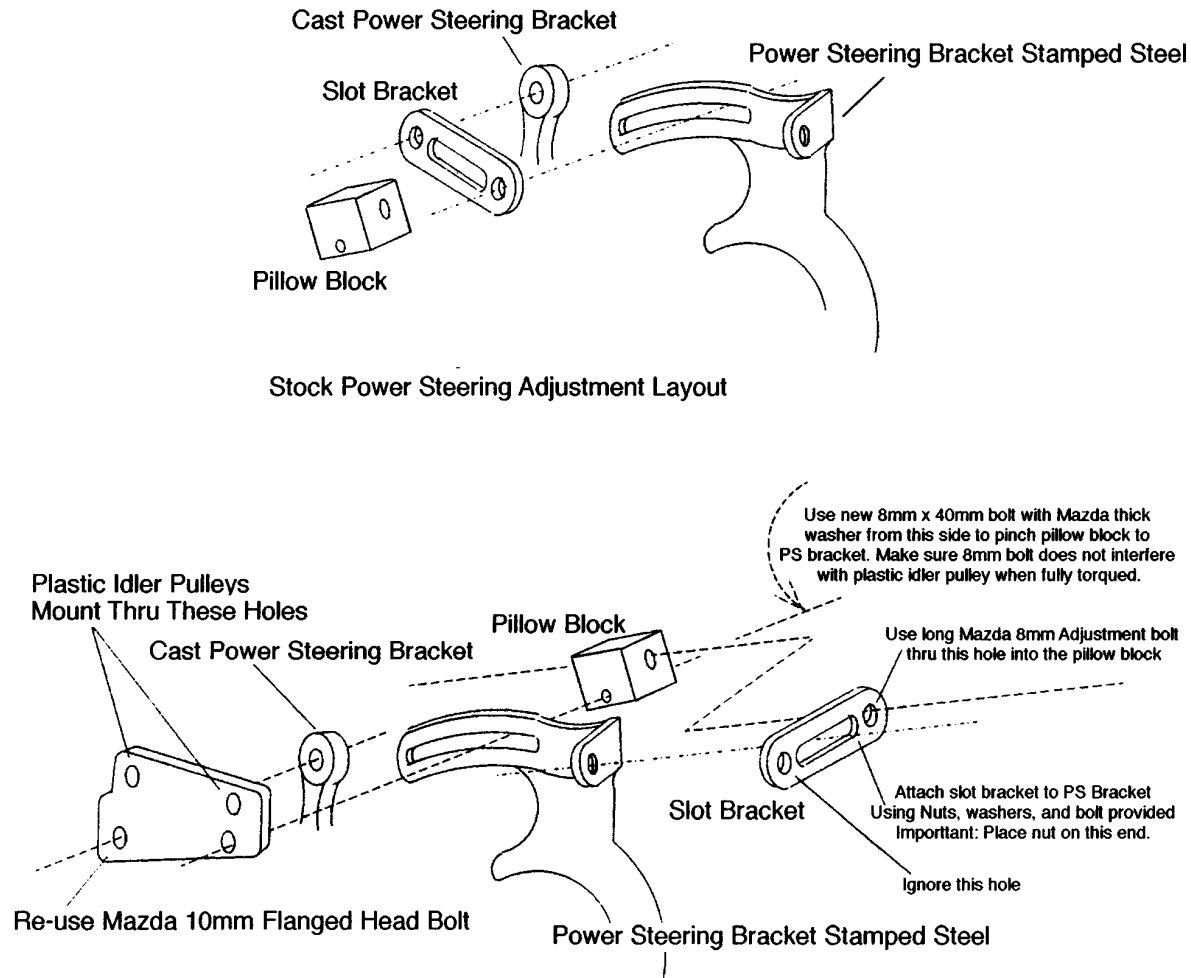

Power Steering Adjustment Components for Supercharger Installation

Figure 3.2

3.2 When you are done with your trial fitting of the flat idler pulley bracket, take this flat bracket to a workbench and install the two nylon idler pulleys using the spacers, bolts and nyloc nuts provided. Make sure that the bolts point toward the front of the car.

3.3 Secure the idler pulleys firmly to the flat bracket. Proceed to install the idler pulley assembly onto the car per the procedure practiced during the trial fitting. The final assembly (minus the pulleys) should look like figure 3.3.

VERY IMPORTANT: MAKE SURE THAT THE DRIVER'S SIDE IDLER PULLEY IS FREE TO SPIN. THE PINCH BOLT THAT YOU INSTALL THROUGH THE PILLOW BLOCK FROM THE REAR CAN INTERFERE WITH THE BACKSIDE OF THE IDLER IF INSTALLED INCORRECTLY (i.e. leaving out the thick washer under the bolt's head). TEST THE ASSEMBLY BY TIGHTENING THE PINCH BOLT FULLY AND SPINNING THE IDLER PULLEY. USE ADDITIONAL WASHERS UNDER THE PINCH BOLT'S HEAD IF NECESSARY.

VERY IMPORTANT: Check the clearance

Supercharger Installation Instructions

between the small coolant hose that runs from the base of the thermostat housing and the passenger side plastic idler pulley (see figure 8.1). If the clearance is less than 1/2 inch between the hose and the pulley, trim three quarters of an inch of length off of the thermostat end of the small hose. Reinstall the hose, reusing the spring clamp. By removing a small piece of the hose end, the hose will be pulled away from the idler pulley, avoiding any damage during operation. This is a critical area for attention since a hose failure could cause severe engine damage. Not all cars need this modification.

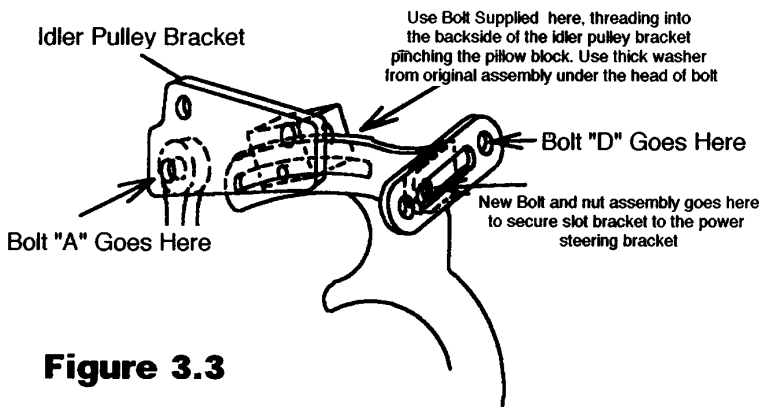

Figure 3.3

Final Component Assembly For Supercharger Installation.
Pulleys Removed for Clarity

3.4 POWER STEERING CARS: Spin the power steering pump pulley until the nut on the main pump mounting bolt is visible. Insert a socket wrench (deep 14mm) here and hold the rear hex head with a 14mm box wrench. Remove the nut and the long bolt (item "B" in figure 3.1). The bolt will retract rearward underneath the exhaust manifold.

3.5 Pick the flat steel supercharger bracket from the kit and slip the long power steering pump mounting bolt through the non-slotted end. Reinstall the power steering pump bolt and nut with the flat bracket pinched between the bolt head and the cast power steering pump bracket

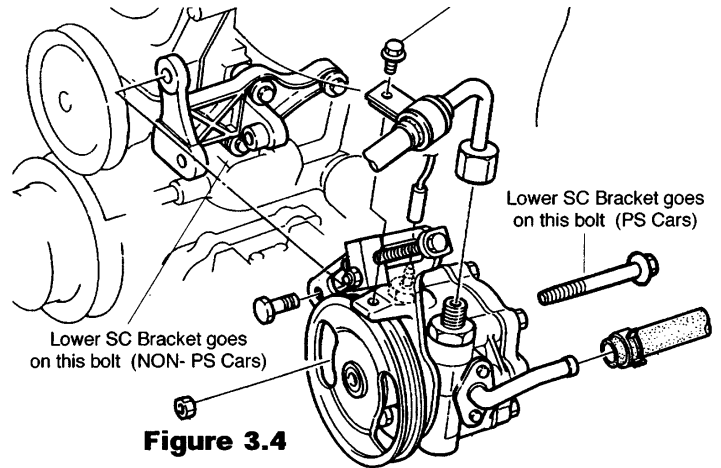

Figure 3.4

that is on the engine. When finished, rotate the power steering pump as far down as possible (the pulley will touch the AC compressor pulley if so equipped). This will allow room for the supercharger to be installed and for the belt to slip over the pulleys.

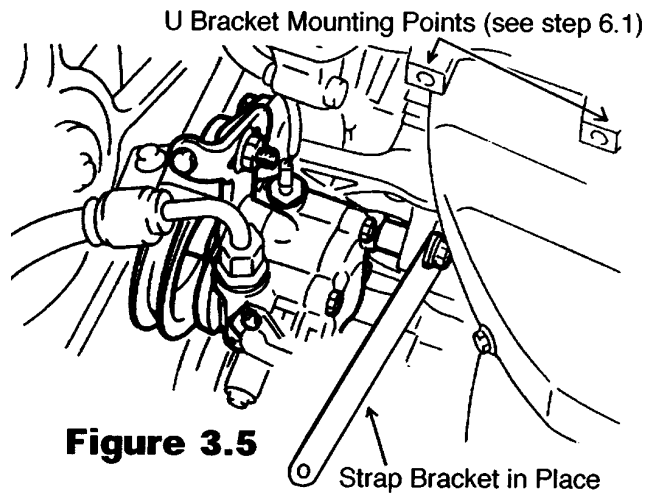

Figure 3.5

3.6 NON POWER STEERING CARS: Locate your lower bracket assembly from the kit. The end with the small 90-degree bracket mounts to the idler bracket (standard on AC equipped cars) or to new idler bracket (supplied with kit for non-AC, non-PS cars). Use the new, longer 10mm bolt provided to attach this bracket to the engine (Review figure 3.4 for bolt location).

Supercharger Installation Instructions

4.0 FUEL MANAGEMENT

4.1 Locate the Mazda fuel pressure regulator at the firewall end of the fuel injector rail. There is a short vacuum hose running to it that initiates on the top rear of the intake manifold. Follow the fuel hose that runs from the bottom of the Mazda pressure regulator to the metal fuel pipe on the passenger side of the engine compartment, just near the intake manifold. It will have a white paint mark on it. This is the fuel return hose. Remove the fuel return hose from the metal fuel pipe attached to the chassis, being careful not to spill any fuel. Make sure that you have released the pressure in your gas tank by removing your gas cap first.

4.2 Locate your Auxiliary Fuel Pressure Regulator (AFPR) from the kit.

4.4 Install the Air/Fuel Regulator by first removing the cylindrical black plastic evaporative canister on the right side of the engine compartment from its vertical mounting brace. This is performed by

simply sliding the canister upward to remove it. There is a small hole in the brace through which will pass a 6 mm bolt with a 10mm head to fasten the mounting clamp of the Air/Fuel Regulator. Mount the AFR to the brace after connecting the fuel lines. Locate the flexible fuel line attached to the REAR (towards the windshield) of the metal fuel rail that connects the Fuel injectors. Follow this fuel line to the rigid pipe just below the Evap. cannister; this pipe will be marked with either a white spot or stripe. Disconnect the flexible fuel line from the rigid pipe and connect it to the offset brass barb on the bottom of the A/F regulator. Connect a new piece of fuel line to the remaining center brass barb and to the rigid pipe with the white mark, this can be achieved by making a large gentle curve between the two connections. Ensure that there are no kinks to obstruct fuel flow in any of these lines. Reinstall the Evap. Canister by sliding it back on it's mounting brace.

5.0 SUPERCHARGER PREPARATION

5.1 Working on a table, set the supercharger unit

MOSS AFR

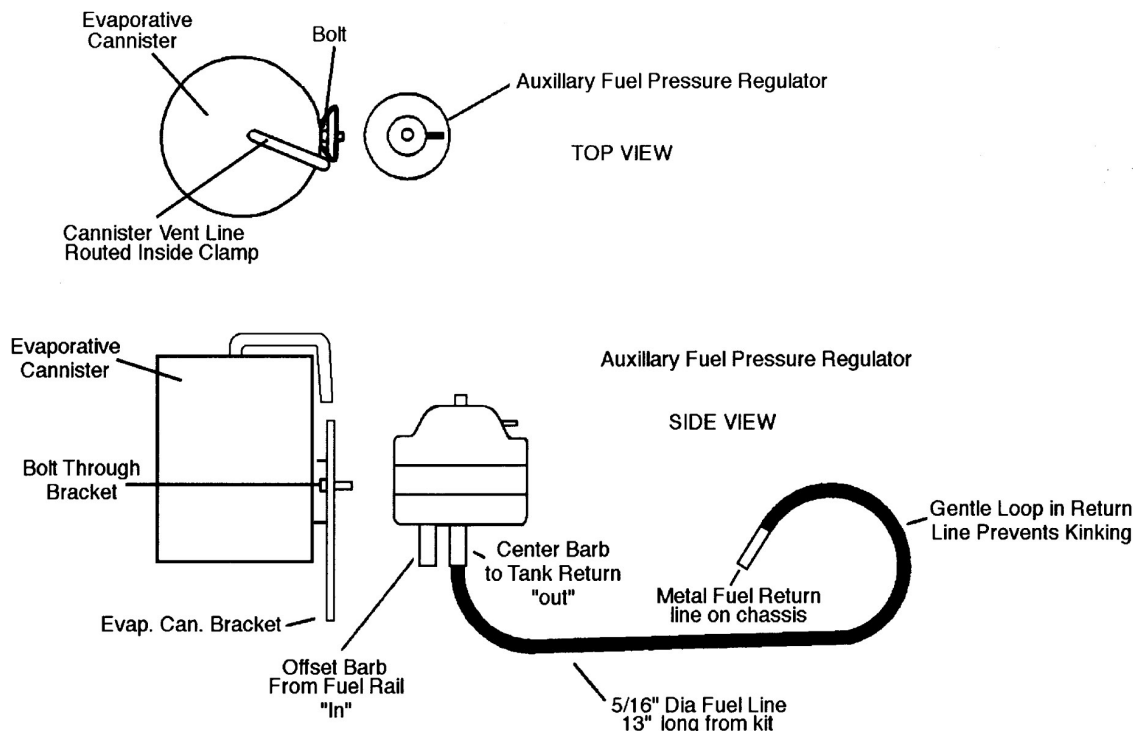

Supercharger Installation Instructions

in a position easy to work with. Be very careful not to bump the supercharger pulley in any way as it can easily damage the front bearing. Check outlet manifold for debris and clean it out if necessary. Install the outlet manifold as shown in figure 5.1 using the bolts from kit bag #2. Get your Mazda throttle body with the ICS blanking plate as installed in step #2.7 and mount it to the supercharger using a thin film of the sealant provided and the four bolts (8mm x 40) supplied in the kit.

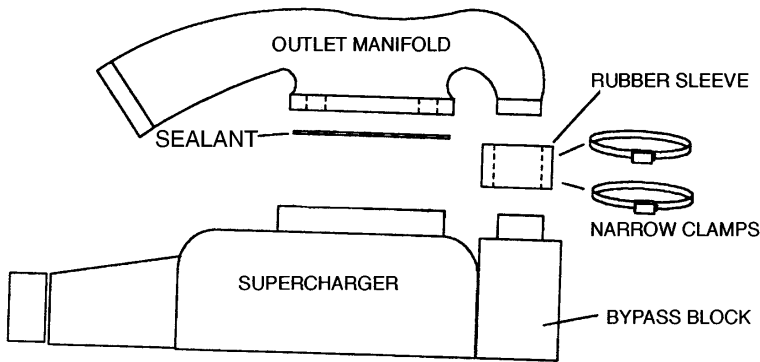

Figure 5.1

5.2 Locate your throttle cable bracket that is bolted to your standard intake manifold and remove the throttle cable by loosening the pinch nuts surrounding the cable end on either side of the bracket. Once the nuts are loose, you can pull

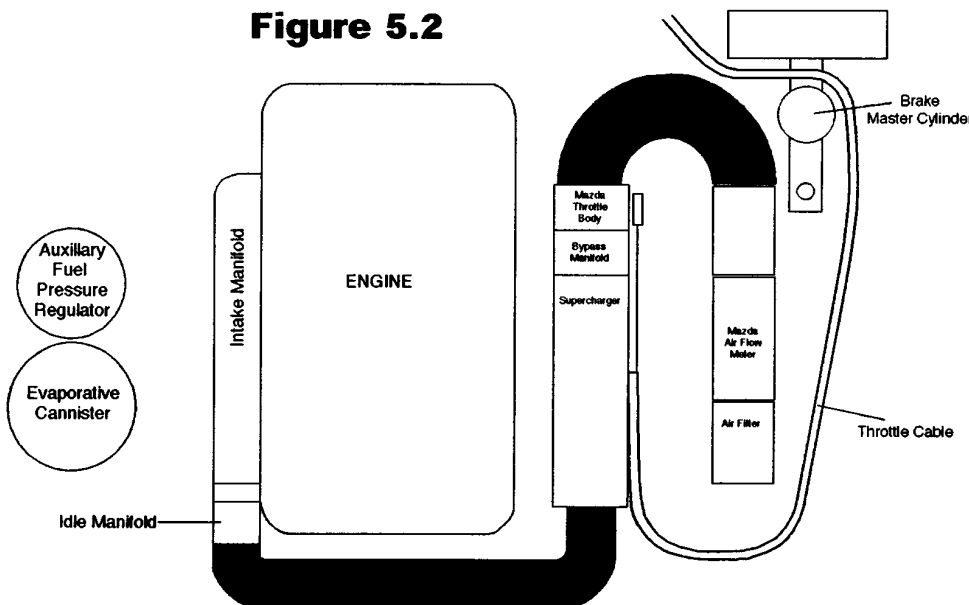

Figure 5.2

the cable out of the bracket - the grommet will deform and let you do this. Remove the throttle cable bracket by removing the two 10mm headed bolts. Unclip the throttle cable from the firewall anchors. Begin re-routing the throttle cable by looping the end behind the brake master cylinder and laying it along the driver's side fender well.

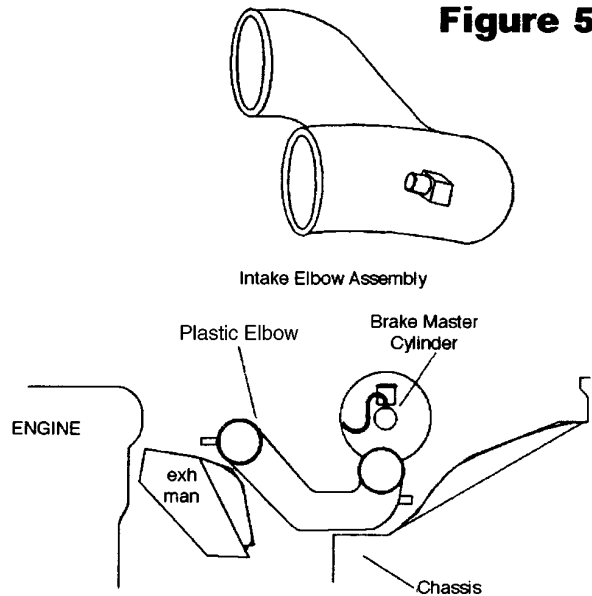

Figure 5.3

5.3 Locate the black plastic Roto-mold inlet elbow from your kit. Check elbow for debris and clean it out if necessary. You will be placing the assembly into the position shown prior to installing the supercharger. Make sure to install the 2.5" to 2.75" reducer hose to the air-flow meter end of this plastic elbow prior to setting it in place. This will greatly assist in airflow meter installation. Also, install the 2.5" diameter hump hose to the throttle body end of this plastic elbow. Use the clamps provided to secure the hoses to the elbow

Supercharger Installation Instructions

6.0 SUPERCHARGER INSTALLATION

6.1 Remove the engine lift eyelet at the front of the engine, just above the exhaust manifold by removing the bolt using a 14mm socket. Using the two new flanged headed bolts supplied with your kit, install these to the two bosses on the side of your cylinder head. Leave at least 1/2" of thread exposed on each bolt.

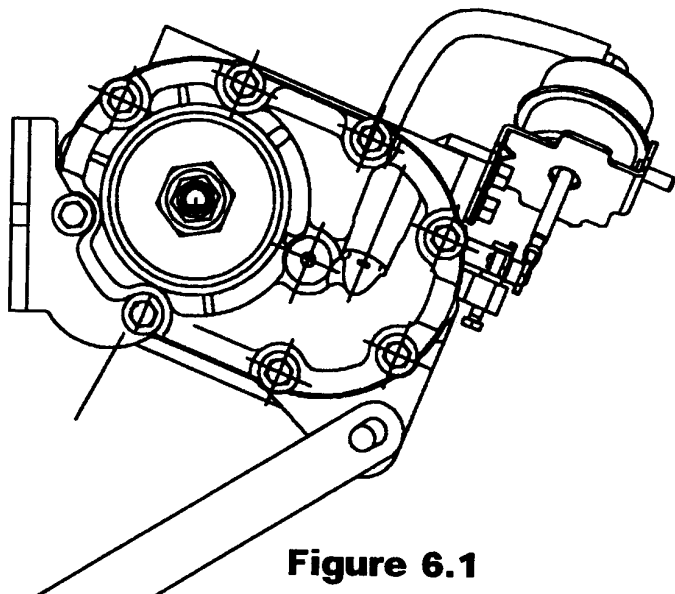

Figure 6.1

6.2 Bring the supercharger over to the engine. Feed the throttle body end into the hump hose already installed on the black plastic "air flow meter to throttle body elbow" (make sure to slip a fully opened hose clamp over the hose first). Orient the supercharger so that you can slip the large "keyholes" in the bracket attached to the supercharger over the two bolt heads installed in step #6.1. Make sure that the bolts move up their respective vertical slots and seat against the upper edge of the horizontal slots in the bracket. Slide the supercharger towards the firewall as far as it will go. Tighten down the two pinch bolts using an open-end wrench. If you find that the bracket/supercharger assembly collides with your cam cover vent tube during initial installation, it means you did not leave enough threads exposed on the two main mounting bolts installed in step #6.1. Retry it with the bolts further out.

6.4 Swing the flat lower bracket up into place in front of the supercharger boss. Locate the small stamped throttle cable bracket from your kit and thread the new bolt through the throttle cable bracket hole, through the supercharger boss and

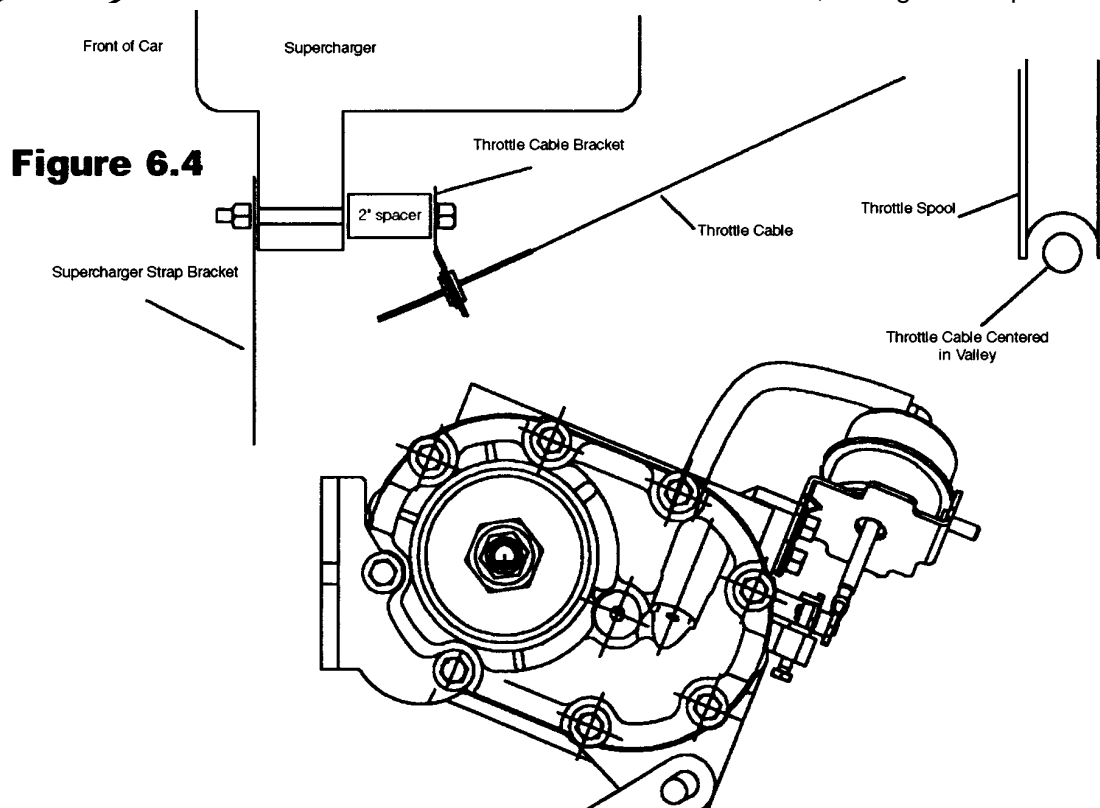

Figure 6.4

Supercharger Installation Instructions

through the flat steel lower bracket. Secure with the locking nut and bolt supplied. Make sure that the head of the bolt is on the throttle bracket side of the assembly. Leave the power steering pump long bolt and nut finger tight (14mm heads).

6.6 Route your throttle cable so that it is looped back toward the firewall, routing the cable just behind the driver's side headlamp motor. Install the cable's threaded end into the small bracket attached to the underside of the supercharger. **Make certain that the cable/grommet is fully nested within the slot** (this may require some muscle - we made it tight so your throttle cable won't ever fall out). Open the throttle by hand and insert the cable end into the throttle spool. Make sure that the cable runs in the center of the groove of the throttle spool. If it does not, adjust the throttle cable bracket left or right until it is centered in the spool's groove. Have an assistant operate the gas pedal multiple times to confirm that the action is free and easy without binding or interference. Make sure that the cable has a bit of "sloppy" slack with the gas pedal released and that full throttle is available when the gas pedal is fully depressed. If it does not "flop" in the idle position, you will have trouble setting your idle speed. Make sure that the cable is run in such a way as to allow for engine movement from side to side.

Make very certain that all throttle cable-mounting points are secure - this installation

area is critical for safe operation of your car. This bracketry has been carefully designed for correct operation. It is your responsibility as the installer to ensure that it is bolted together successfully without binding or interference.

6.7 Connect the 48+” long vacuum hose (supplied) to the hose barb on the supercharger's bypass manifold. Use the horizontal hose barb that is pointed rearward toward the car's firewall. Carefully tie this hose off so it neatly crosses the engine compartment and does not interfere with any critical areas. It can neatly fit into the firewall clips that used to hold your throttle cable. If you find the line is too long, trim to the proper fit. Connect the other end of the vacuum line to the AFPR, making sure that there is enough slack to allow for engine movement.

7.0 AIRFLOW METER WORK

7.1 Locate the new air filter base from your kit and install it to the air flow meter intake port, reusing the Mazda cork gasket and four nuts. The air flow meter is offset toward the top of the air filter base. The seven pin electrical connector on the airflow meter faces upward.

7.2 Locate the driver's side shock tower support and notice the Mazda air filter box mounting bracket (painted body color) on the forward edge. This vertical bracket is held in place by a hori-

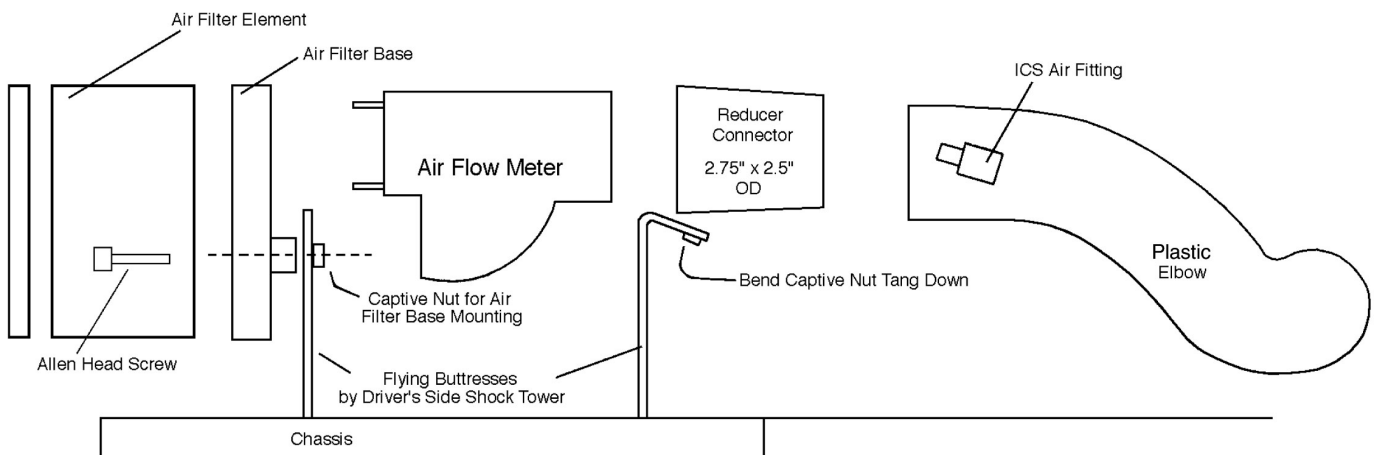

Side View of Air Flow Meter Mounting

FIGURE 7.2

Supercharger Installation Instructions

zontal bolt (also painted body color). Remove the bolt using a 10mm socket and store the bracket. On the “flying buttress” closest to the firewall, bend the captive nut tang downward to make room for the plastic elbow section using a small screwdriver in the hole.

7.3 Bring the air flow meter with the air filter base installed over to the engine bay. Tilting the assembly at an angle, feed the air flow meter outlet into the rubber reducer sleeve already in place on the plastic elbow (install loose hose clamp first). The air flow meter assembly fits into the space just inside the shock tower, between the two “flying buttresses” of the shock tower. The extra hole and boss in the air filter base will line up with the horizontal hole you just removed the 6mm body colored bolt from. Using the longer bolt provided (M6 x 30mm, Allen head), attach the air filter base/air flow meter assembly to the car using this bolt (it mounts horizontally, through the air filter base, the flying buttress, and into the Mazda captive nut on the flying buttress). Use thread-locking compound.

7.4 Make sure that there is no chaffing or rubbing anywhere along the plastic elbow assembly, even though it is a very tight fit. Gently reposition any brake lines that are pressing against the elbow. Make sure all joints and clamps are secure - a leak in this area will keep your car from idling correctly. However, never over tighten your clamps, they may break somewhere down the road.

Use the small length of rubber hose (1/4” dia) that is slit along its length to cover the brake line running just above the elbow. This will prevent any contact at this point, which may result in noise during operation.

7.5 Locate the 3/4” diameter idle air hose (5’ length) from your kit. Attach one end to the ‘large’ outside fitting on the plastic elbow downstream of the airflow meter (just below the brake master cylinder once the elbow is in place). Use a clamp to secure the hose to the short 3/4” nipple. Run

the hose toward the front of the engine compartment, and across the engine side of the radiator. Using the tie wraps provided, attach the rubber hose securely to the radiator fan shroud supports near the fan motor(s). Attach the end of the hose to the idle control (ICS) valve nipple that is aimed toward the front of the vehicle. Make sure that the hose is attached in a way that will not interfere with either fan operation or with the engine belts. At a point along the length of the hose behind the radiator, cut it and install the check valve supplied. Install the check valve with the flanged end toward the plastic elbow using the small hose clamps. **See figure 7.6.** The hose is supplied a bit longer than it needs to be. Feel free to trim its length if you prefer. Be careful not to pinch the hose at any point - doing so will affect your idle stability. You want to have it tie-off in a low position; the cross over tube will fit above this hose, hiding it in the final installation. On some cars, there might be a slight kink in the hose where it attaches to the plastic elbow nipple. This is acceptable - orient the hose so it remains open.

7.6 Install the air filter element over the air filter base. Next, collect the two studs and install them with the element in place. Install the waffle-patterned air filter cap and secure using the nuts provided. Use the tie-wraps provided to secure all components and keep them clear from the belt runs, exhaust manifolds, and especially the throttle cable. Re-route the air bag harness over the air filter, keeping it away from the headlight raising motor.

IMPORTANT! Secure the air bag harness with tie wraps to keep it from falling into the engine belt system or being pinched in any way.

7.7 Take the throttle body wiring harness extension as left in step #2.6 and route the body of the harness along the firewall using the bright cad plated firewall clips that originally held the throttle cable on your stock Miata. Tie-wrap the extension harness along the firewall in at least two places. Make sure to leave enough slack on both

Supercharger Installation Instructions

ends to allow the engine to rock side to side without pulling on the harness. Contain any extra length in a neat fashion. Connect the female end to the throttle body at the throttle position sensor.

7.8 Find the internal restrictor taken out of your PCV hose in step #1.4. Locate the 3/8" internal diameter rubber hose from your kit and press the restrictor into this hose at least one inch. Attach this hose from the 'medium' size fitting on the plastic intake elbow (near the throttle body, pointing to the engine). Cut to length and attach the other end to the camshaft cover fitting on the exhaust side. Make sure the hose does not kink at any point and that the restrictor is not left out. If you leave the small restrictor out, the engine will not idle correctly.

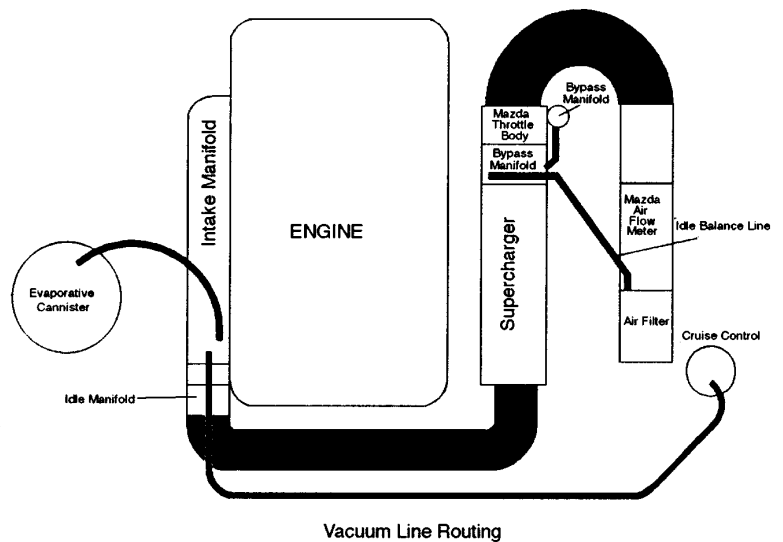

7.9 Locate the 7/32" internal diameter idle balance hose and attach it to the 'small' fitting on the plastic elbow. Attach the other end to the unused vertical vacuum nipple on the bypass block of the supercharger. Cut the line to the proper length, leaving some slack to allow for engine movement. Make sure the line is not pinched in any way and that it has no possibility of interfering with the throttle cable or spool. Use tie wraps as necessary to secure the line. The diagram in figure #7.5 shows the bypass actuator signal line being attached to the engine side nipple on the bypass manifold. It may be connected to the fender side nipple—either is acceptable. Connect your idle balance line to whichever vertical nipple is unused. The bypass actuator may have two nipples on its "can". The upper one is used in this kit. The lower nipple should be left open - it is used in the GM factory installations.

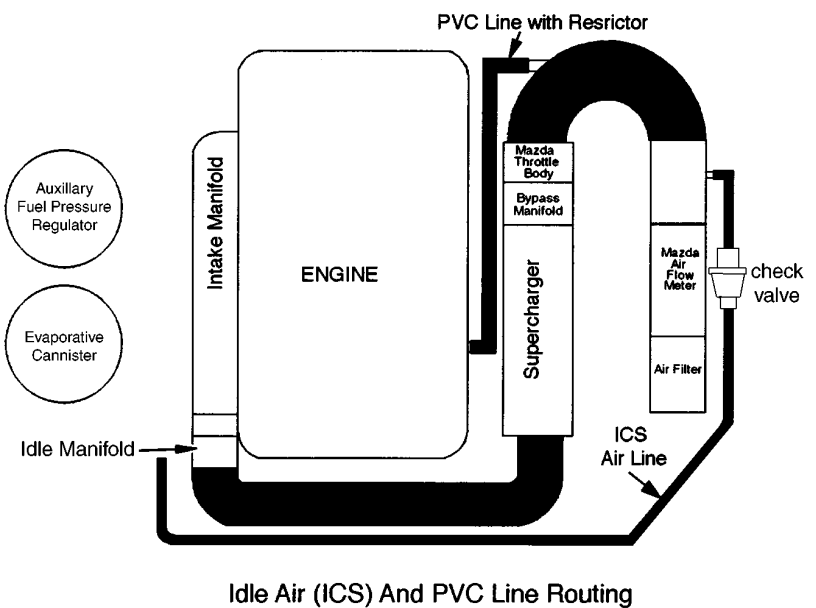

Figure 7.5

7.10 Reconnect the 7 pin electrical connector to the air flow meter. Make sure the harness is not pinched at any point.

8.0 FINAL ASSEMBLY

8.1 Install the new 4-rib drive belt. This new belt will run counter-clockwise from the crankshaft, around the air conditioning compressor, up to the power steering pump, over to the right nylon idler pulley, up and over the supercharger pulley, just under the left nylon idler pulley, and back down to the crankshaft. Figure 8.1 shows the belt run for

Supercharger Installation Instructions

configurations A-D listed below. If you find the belt to fit too tightly, gently rock the car in fourth gear while pressing the belt onto the pulley using the following trick. Put the belt on all pulleys EXCEPT the supercharger pulley, which you should leave for last. Feed the belt onto the supercharger pulley in a COUNTERCLOCKWISE direction; place the car in fourth gear with the handbrake off (and the ignition keys OUT!). Gently roll the car backwards with your body weight while insuring that the belt feeds itself onto the supercharger pulley the last little bit. Watch out for your fingers. Make sure the belt does not roll off of either inside idler pulley while it feeds onto the supercharger pulley.

UNDER NO CIRCUMSTANCES SHOULD YOU USE THE ENGINE STARTER TO “BUMP” THE BELT ONTO THE SUPERCHARGER. DOING SO PUTS A HIGH LOAD ON THE SUPERCHARGER BEARING AND WILL VOID YOUR WARRANTY. ALSO, IT IS VERY DANGEROUS.

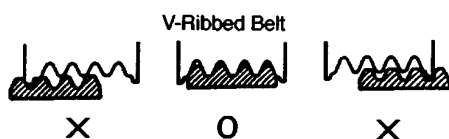

Loosen the pinch bolts on your relocated power steering adjustment assembly (12mm head on pillow block pinch bolt, 14mm head on lower front bolt). Tighten the long bolt “D” per figure 3.4 to achieve correct belt tension. The longest run of the belt should not deflect more than $\frac{1}{2}$ of an inch when pressed down with around 22 pounds of thumb pressure. The tension specification is 90 pounds. An easy check for proper belt tension is done by listening to your belts during warm up. If turning the steering wheel with the air conditioning creates a squeal, then the tension is too loose. In general, only a slight amount of black dust should appear around the supercharger nose when the tension is correct. Heavy dusting

indicates excessive belt wear from a loose belt. Check your tension again after the first 500 miles - it will loosen slightly as the belt wears in.

NEVER ATTEMPT TO ADJUST THE BELT WITH THE ENGINE RUNNING!

Re-tighten all bolts and double-check your work.

8.2 Locate the rubber sleeves and the front cross over tube. Check the inside of the cross over tube for debris - clean if necessary. Running a rag through the pipe pulled by a strong wire is a good way to do this. Install the cross over tube between the idle air manifold (dummy throttle body now on the intake manifold) and the supercharger discharge manifold. If you find the rubber sleeves hard to slip over their respective landings, use some spray light oil such as WD40, which dries off to lubricate the situation. Do not use gasoline products or pure silicone products. The best technique for installing the cross over tube involves putting the 2.75” diameter rubber sleeve on the supercharger manifold and the 2.5” diameter sleeve on the cross over tube, and attach both with clamps. Then install the cross over tube, starting at the supercharger end first.

8.3 If you have cruise control, route the factory vacuum line from the cruise control back to its original position, being careful to tie-wrap it away from the engine belts or radiator fans. Remove the steel spacer from one of the mounting grommets on your stock Mazda air box. Use this 13/16” long spacer and the 6mm x 25mm hex head bolt supplied to secure your cruise control brace to the air filter base. The bolt will go vertically through the cruise control leg brace and into the small ledge with a threaded hole on the air filter base.

8.4 Once the cross over tube is installed correctly, double-check all your pipe and tube connections. There should be no loose ends or connections. Do not over tighten any hose clamps, but ensure that they are snug. Double check your supercharger belt for correct tension. If the cross over tube is pressing too hard against your upper radiator hose, you can remove 3/4” to 1” from the

Supercharger Installation Instructions

radiator end of the hose to allow for more clearance, if you wish. You are now ready to start your engine.

8.5 First, crank your engine for a few seconds with the "FUEL INJ" relay still removed from step 1.1. Confirm that the supercharger belt stays on and that no other parts have been left unattended to.

8.6 Reinstall the "FUEL INJ" relay. Complete step 8.7 before starting your engine.

8.7 CLEARANCES

IMPORTANT!

MAKE SURE THAT YOU HAVE AT LEAST 3/4" INCH CLEARANCE BETWEEN ANY ENGINE MOUNTED COMPONENT AND ANY BODY MOUNTED COMPONENT. CRITICAL AREAS: BYPASS ACTUATOR TO BRAKE LINES (VERY CRITICAL - The engine "rocks" strongly to the driver's side upon deceleration. If clearance is too tight, your brake lines can be gently deformed away from the super-charger bypass actuator by hand.) SUPERCHARGER OUTLET MANIFOLD TO AIR FILTER (INCLUDING CLAMPS) ALL VACUUM LINES TO THROTTLE SPOOL AND CABLE

9.0 ENGINE ADJUSTMENTS

9.1 SUPERCHARGER BELT DRIVE ADJUSTMENT

Start your engine and observe your belt drive. The belt should line up with itself as it passes between the two nylon idlers. To put it a different way, the portion of the belt running up to the supercharger should lay almost directly over the portion leaving the supercharger and heading toward the power steering pulley. If the upward run is more forward or rearward than the downward run, you need to move your supercharger slightly forward or backward with respect to the crankshaft pulley. Remember the two bolts attaching the supercharger's bracket to the cylinder head from step 6.1? You can now access these two bolts with an open-end wrench. Loosen each bolt slightly to allow for adjustment. Start the engine. You can now move the supercharger assembly slightly forward or rearward to correctly align the drive pulleys. The slots

in the Supercharger mounting bracket will allow you to find the perfect alignment for the belt run.

NOTE: Do not attempt to move the supercharger with your hands with the engine running. Use an appropriate tool.

The best tool to use is a flat blade screwdriver placed between the forward bracket bolt and the front inside edge of the bracket. Move the supercharger assembly while watching the belt run the idler pulley. If you have the two bracket bolts too loose, the supercharger will be out of alignment from side to side. Make sure the two bolts are snug enough to just allow some leveraged movement. Once you have the belt running true in the center of the idler pulleys, tighten the rear bolt to secure the position. Shut off the engine and tighten the other bracket bolt securely. Recheck all mounting bolts for tightness.

9.2 IDLE ADJUSTMENT:

Restart your engine. Using the idle airscrew on your throttle body (now on the back of the supercharger), adjust your idle speed to 950-rpm after the engine is warm. This can best be approximated by closing the screw completely (turning clockwise) and backing it out one and a half turns counter-clockwise. Adjust further to reach the 950-rpm value. Next, turn your headlights on BRIGHT and put your heater fan on HIGH. Leave the air conditioning off. Rev the engine briskly in neutral to at least 2500 rpm and release. Notice if the idle stops to 900 rpm. If it dips below this level and feels like it will stall, then recovers to 950 rpm, open the idle airscrew (counterclockwise rotation) one tenth of a turn at a time until

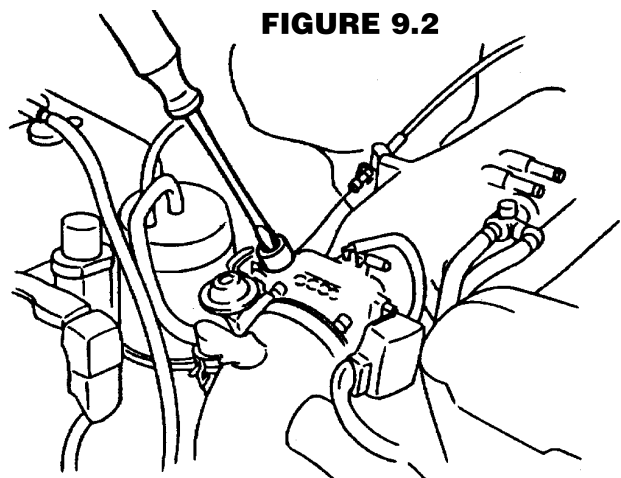

FIGURE 9.2

Supercharger Installation Instructions

most of this “droop” disappears. A slight droop of 100 rpm or so is acceptable and normal. More than that may create a stalling problem during driving.

Turn off the lights and heater fan and double check that your idle speed is 950 rpm. If you open the idle screw too much, you will create too high of an idle speed when the lights and fan are turned off. You also may possibly introduce a stumble on part throttle to full throttle accelerations. In addition, a slow return to idle behavior will occur.

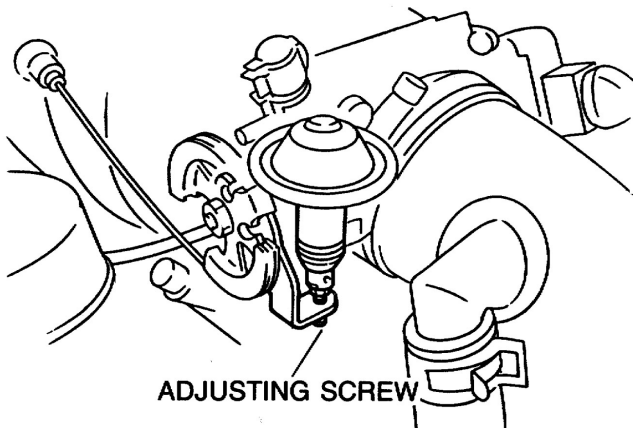

FIGURE 9.2B DASHPOT ADJUSTMENT

9.3 If you have difficulty stabilizing the drooping idle problem, adjust your dashpot to help in slowing the throttle's closing. The factory specification is that the dashpot tip just begins to touch the throttle arm at 2500 rpm. Have an assistant hold the engine at 2500 rpm from the driver's seat.

The dashpot tip should just be touching the throttle arm. Adjust the dashpot so that this contact point is at 3000 rpm or more to help with the drooping idle. Your Miata will drive best with the lowest idle speed possible with only a slight droop in the idle (checked as described above with a warm engine, lights and heater fan on high).

9.4 Using a timing light, adjust your ignition timing to 8 degrees before top dead center (BTDC). You have to run a jumper wire (an unfolded paper clip will do nicely) between terminals “GND” and “TEN” of your diagnostics center (located just above the driver's side shock absorber). The ignition timing is adjusted using the position sensor mounted at the firewall end of the intake camshaft. A 12mm box wrench will loosen the securing bolt. The 8 degree BTDC mark is the one just to the right of the “10” degree mark on the crankshaft pulley as viewed under a timing light.

9.5 IGNITION TIMING AND FUEL QUALITY: Your Miata supercharger kit is designed to operate on 92 Octane fuel. Make sure that you run your engine on 92 octane only, which means you should completely burn up any lower octane gas in your tank and refill it with 92 octane before installing your supercharger kit. **NOTE: If you can only find 91 Octane fuel (R+M/2 method), set your timing to 6 degrees BTDC instead of 8 degrees. If you live in an extremely hot area (temperatures exceeding 100 degrees Fahrenheit), set your timing to 6 degrees**

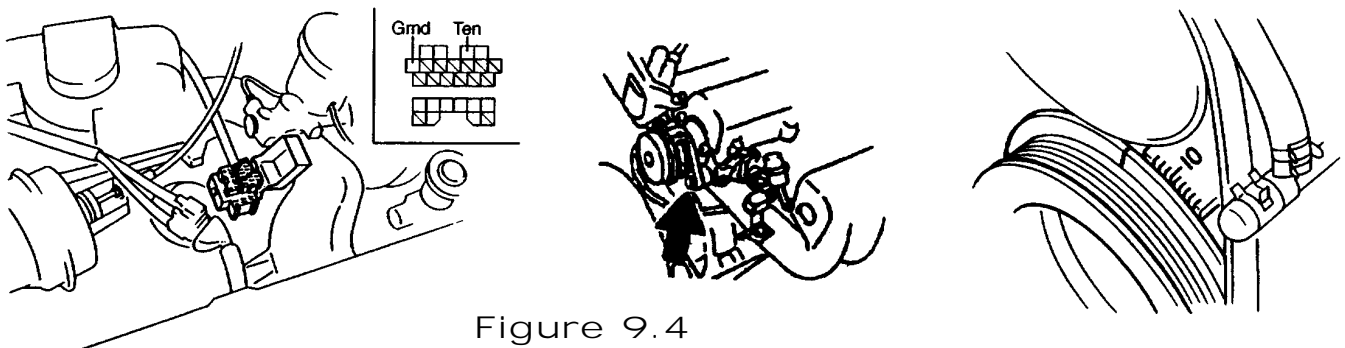

Figure 9.4

Supercharger Installation Instructions

BTDC for an extra margin of safety. In any case, should you ever hear “pinging” or knocking from your engine when under acceleration, you should take measures to eliminate this detonation, i.e. higher-octane fuel or a further retardation in ignition timing. NEVER CONTINUE TO OPERATE YOUR ENGINE IF YOU HEAR ANY SIGNS OF DETONATION (PINGING OR KNOCKING). YOU WILL QUICKLY MELT YOUR ENGINE DOWN!

This kit has been carefully designed to work with in the stock Mazda engine parameters and no detonation will occur if the above settings and fuel are followed. The only way detonation can creep into your situation is if your engine has a mechanical fault, the fuel you are using is of the incorrect octane, if your timing is set incorrectly or if your fuel filter is clogged. It is your responsibility as the installer of this kit to ensure that the supercharger has been installed according to specification.

DRIVING TIP:

If you should find yourself in a situation where you cannot find high-octane fuel, you can bypass the supercharger temporarily. Note the position the bypass actuator arm is in during idle. This is the position that bypasses the boost air back into the supercharger inlet. As you blip the throttle, the actuator arm will move and close a butterfly valve inside the bypass manifold. Using a short piece of wire, fix the bypass actuator arm in the “bypass” position that it holds at idle. This will prevent boost from being developed and thus, detonation will not occur. Of course, your engine will now run like a stock Miata’s, but will be quite operable for as long as you need. When you find higher-octane fuel, simply remove the wire to release the actuator arm and the bypass will function normally, closing during acceleration, bypassing during idle and cruise. Try to run the low octane fuel out of your tank before filling up. Mixing fuels of different octane will lower the overall rating and detonation could still be a problem.

You can order a Jackson Racing Boost Timing Controller that retards your timing during boosted conditions. This is useful for those who can only find 91 Octane fuel or wish to increase their low-end power by advancing the static ignition timing.

9.6 Starting procedure: Start your engine as you would a standard Miata. Remember to bring the engine up to operating temperature (as indicated by your water temperature gauge) before running it hard. Full boost on a cold engine will greatly increase your engine wear.

9.7 Oil changes: we suggest you use synthetic oil such as Mobil 1 and change it regularly (5000 miles maximum). If you use a mineral oil, change it every 2500 miles. While your supercharger does not use any engine oil for its lubrication, your engine will be working a little harder with the addition of a supercharger. The synthetic oil provides an extra measure of protection, but is not necessary for safe and reliable operation.

9.8 Breaking-in: Your supercharger will work perfectly from the first time you fire it up. However, it does need about 500 miles to fully seat the rotors. Up to that time, you may notice a slight noise coming from the supercharger at idle. This is normal.

9.9 Performance: You will notice that your engine runs stronger on cold days than on very hot ones. This is due to the nature of the internal combustion engine. When the air is cold, the engine receives a denser charge of air, thus more power can be produced. While this is true with any engine, the supercharger amplifies this cold air benefit.

10.0 LONG TERM MAINTENANCE

10.1 BELTS

The only item to watch with your supercharger kit will be the belt tension for the supercharger drive. If you have a tension gauge for a poly-vee belt, the tension is to be 90 pounds. Without a gauge, look for less than 1/2” of deflection on the long run of the belt. If you see a large accumulation of belt dust on your supercharger, it is an indication that your belt is slipping. A slight amount of belt dust is normal. **CHECKING YOUR BELT FOR WEAR:** As the belt wears, small cracks will form in each of the ribs on the inside run of the belt. Replace your belt when you can count six cracks within in one inch of length (six cracks total from all ribs combined).

Supercharger Installation Instructions

10.2 DRIVEABILITY

If you notice a driveability problem as your car ages, have your fuel pressure checked. The variable fuel regulator supplied with this kit increased your fuel injection system's pressure as boost is applied from the supercharger. Have a technician install an accurate 0 to 100psi fuel pressure gauge in the fuel line BEFORE it enters the fuel rail (the fuel line you did not disturb during this installation). With the engine running, but the vacuum line to the auxiliary fuel pressure regulator disconnected, the fuel pressure should be 48 to 52psi. If it is not, the Allen head screw on top of the fuel regulator can be retracted or tightened to adjust the base fuel pressure. Make sure to temporarily connect the vacuum line to cycle the AFPR diaphragm when checking the baseline pressures.

10.3 Every six months or so, check your hose clamps for correct tension. The rubber hoses will take a set and the clamps may not be holding as tight. Also check all mounting bolts and nuts, particularly the throttle cable anchor bracket. 10.4 Your air filter is a long-life unit needing service only every 15,000 miles. To clean, you can wash the filter element in soap and water. Use a dish detergent soap such as Dawn, etc. Rinse thoroughly and allow to dry. Wet the filter element with a light application of ATF (automatic transmission fluid). Alternatively, a special cleaning kit is available from Jackson Racing (#901-970).

10.5 At every oil change, lubricate the bypass actuator arm contact point and shaft bushing with light grease to insure long life - these parts are exposed to under hood dirt and grime.

TROUBLESHOOTING

SYMPTOM: Engine cranks but will not start

PROBABLE CAUSES: Airflow meter disconnected; Idle air line open; Low battery voltage

CURE: Double check that seven pin to airflow meter is well connected. Re-check the 3/4" ICS line and the PCV line to see that they are not leaking. Use a known good battery to "jump" the Miata's battery. It is possible to have enough voltage to crank a Miata but not enough to correctly run the engine's control computer.

SYMPTOM: No power during boost

PROBABLE CAUSES: Incorrect boost signal to Fuel Pressure Regulator, Pinched fuel lines, cross over tube loose.

CURE: Check signal line to AFPR for 17 inches of Hg vacuum at idle, at least 5psi of pressure during boost. Make sure line is not pinched or blocked. Make sure that line is attached to the correct nipple on bypass block. Blow into the AFPR signal line to confirm that there is no leakage of boost signal air. Check fuel lines for kinking. Check the cross over tube to see that it is well connected at both ends.

SYMPTOM: Unstable Idle

PROBABLE CAUSE: Idle air screw set incorrectly; Restrictor left out in step #7.8; Pinched idle air balance line; air leak in intake track.

CURE: Re-check restrictor. Check idle adjustment procedure in step 8.1 above. Check the idle air balance line for restriction or pinching. Check for air leaks - vacuum at idle should be at least 17.7 in Hg.

11.0 FURTHER MODIFICATIONS

Now that your Miata has a stronger engine, there are a few changes you might want to make to the rest of the car to improve its performance. The following are not required for your supercharged Miata, but are presented as tuning hints for a better all-around car.

We recommend that you install a Jackson Racing Stage 1 clutch when it comes time to put in a new clutch. While your new supercharger and the standard Mazda clutch work well together, it is a good idea to step up to the Jackson Racing unit when you are changing your clutch.

We recommend you install a set of Jackson Racing larger diameter anti-roll bars for the suspension for your Miata. These will tighten up your steering response. We also recommend a new set of Tokico shock absorbers if your Miata has over 30,000 miles on it. The Tokico shocks coupled with a set of the Jackson Racing Sport lowering spring will lower the car about 35mm. This combination yields better handling with out the harsh ride of competition springs. Have your car aligned afterward (driver's equivalent weight in the driver's seat) to factory specifications after any suspension changes.

You might want to add a Jackson Racing Boost and A/F ratio gauge to your supercharged Miata. These are good for keeping an eye on things.

A performance exhaust will make your supercharged Miata that much faster. Since you are

Supercharger Installation Instructions

now flowing 300 cubic feet per minute through a muffler designed for 177cfm, an improvement can be made. Jackson Racing offers a Stainless Steel Cat-back exhaust system designed around the Supercharger.

Further performance improvements can be obtained through the use of the Jackson Racing Boost-timing controller. This timing controller constantly adjusts ignition timing based on boost and RPM. This will allow you to make the most power safely.

WARRANTY: The supercharger system carries a two-year or 100,000 mile warranty (for the original purchaser of the kit) against defects in materials and workmanship. No other warranties apply. This warranty is void if the subject vehicle is used in any racing activities of any sort.

HELP: If you experience any problems with your kit during installation or operation, contact your retailer or Jackson Racing at 1-888-888-4079