



Installation, Operation, and Maintenance

VariTrane™ Variable Air Volume

(VAV) Terminal Air Units

Shutoff, Fan Powered, and CoolSense™

Sensible Cooling

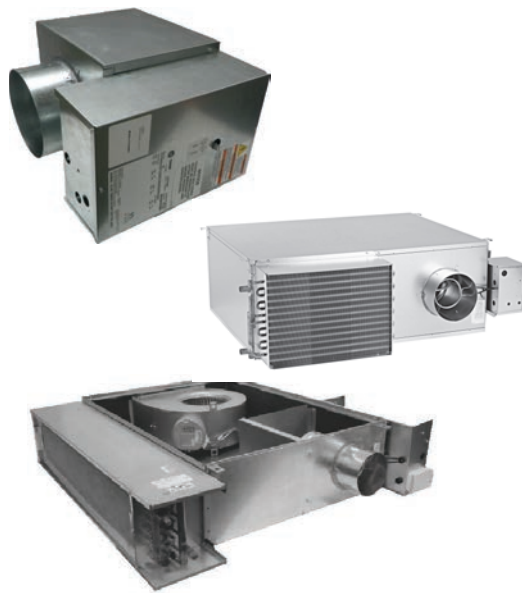

Single-Duct: VCCF, VCEF, VCWF

Dual-Duct: VDDF

Fan-Powered: VPCF, VPEF, VPWF, VSCF, VSEF, VSWF

Fan-Powered Low Height: LPCF, LPEF, LPWF, LSCF, LSEF, LSWF

Chilled Water Sensible Cooling Terminal Units: LDCF, LDEF, LDWF

⚠ SAFETY WARNING

Only qualified personnel should install and service the equipment. The installation, starting up, and servicing of heating, ventilating, and air-conditioning equipment can be hazardous and requires specific knowledge and training. Improperly installed, adjusted or altered equipment by an unqualified person could result in death or serious injury. When working on the equipment, observe all precautions in the literature and on the tags, stickers, and labels that are attached to the equipment.



Introduction

Read this manual thoroughly before operating or servicing this unit.

Warnings, Cautions, and Notices

Safety advisories appear throughout this manual as required. Your personal safety and the proper operation of this machine depend upon the strict observance of these precautions.

The three types of advisories are defined as follows:



Indicates a potentially hazardous situation which, if not avoided, could result in death or serious injury.



Indicates a potentially hazardous situation which, if not avoided, could result in minor or moderate injury. It could also be used to alert against unsafe practices.



Indicates a situation that could result in equipment or property-damage only accidents.

Important Environmental Concerns

Scientific research has shown that certain man-made chemicals can affect the earth's naturally occurring stratospheric ozone layer when released to the atmosphere. In particular, several of the identified chemicals that may affect the ozone layer are refrigerants that contain Chlorine, Fluorine and Carbon (CFCs) and those containing Hydrogen, Chlorine, Fluorine and Carbon (HCFCs). Not all refrigerants containing these compounds have the same potential impact to the environment. Trane advocates the responsible handling of all refrigerants-including industry replacements for CFCs and HCFCs such as saturated or unsaturated HFCs and HCFCs.

Important Responsible Refrigerant Practices

Trane believes that responsible refrigerant practices are important to the environment, our customers, and the air conditioning industry. All technicians who handle refrigerants must be certified according to local rules. For the USA, the Federal Clean Air Act (Section 608) sets forth the requirements for handling, reclaiming, recovering and recycling of certain refrigerants and the equipment that is used in these service procedures. In addition, some states or municipalities may have additional requirements that must also be adhered to for responsible management of refrigerants. Know the applicable laws and follow them.

⚠ WARNING

Proper Field Wiring and Grounding Required!

Failure to follow code could result in death or serious injury.

All field wiring **MUST** be performed by qualified personnel. Improperly installed and grounded field wiring poses **FIRE** and **ELECTROCUTION** hazards. To avoid these hazards, you **MUST** follow requirements for field wiring installation and grounding as described in **NEC** and your local/state/national electrical codes.

⚠ WARNING

Personal Protective Equipment (PPE) Required!

Failure to wear proper PPE for the job being undertaken could result in death or serious injury. Technicians, in order to protect themselves from potential electrical, mechanical, and chemical hazards, **MUST** follow precautions in this manual and on the tags, stickers, and labels, as well as the instructions below:

- Before installing/servicing this unit, technicians **MUST** put on all PPE required for the work being undertaken (Examples; cut resistant gloves/sleeves, butyl gloves, safety glasses, hard hat/bump cap, fall protection, electrical PPE and arc flash clothing). **ALWAYS** refer to appropriate Safety Data Sheets (SDS) and OSHA guidelines for proper PPE.
- When working with or around hazardous chemicals, **ALWAYS** refer to the appropriate SDS and OSHA/GHS (Global Harmonized System of Classification and Labelling of Chemicals) guidelines for information on allowable personal exposure levels, proper respiratory protection and handling instructions.
- If there is a risk of energized electrical contact, arc, or flash, technicians **MUST** put on all PPE in accordance with OSHA, NFPA 70E, or other country-specific requirements for arc flash protection, **PRIOR** to servicing the unit. **NEVER PERFORM ANY SWITCHING, DISCONNECTING, OR VOLTAGE TESTING WITHOUT PROPER ELECTRICAL PPE AND ARC FLASH CLOTHING. ENSURE ELECTRICAL METERS AND EQUIPMENT ARE PROPERLY RATED FOR INTENDED VOLTAGE.**

⚠ WARNING

Follow EHS Policies!

Failure to follow instructions below could result in death or serious injury.

- All Trane personnel must follow the company's Environmental, Health and Safety (EHS) policies when performing work such as hot work, electrical, fall protection, lockout/tagout, refrigerant handling, etc. Where local regulations are more stringent than these policies, those regulations supersede these policies.
- Non-Trane personnel should always follow local regulations.

⚠ WARNING

Fiberglass Wool!

Exposure to glass wool fibers without all necessary PPE equipment could result in cancer, respiratory, skin or eye irritation, which could result in death or serious injury. Disturbing the insulation in this product during installation, maintenance or repair will expose you to airborne particles of glass wool fibers and ceramic fibers known to the state of California to cause cancer through inhalation.

You **MUST** wear all necessary Personal Protective Equipment (PPE) including gloves, eye protection, a NIOSH approved dust/mist respirator, long sleeves and pants when working with products containing fiberglass wool.

Precautionary Measures:

- Avoid breathing fiberglass dust.
- Use a NIOSH approved dust/mist respirator.
- Avoid contact with the skin or eyes. Wear long-sleeved, loose-fitting clothing, gloves, and eye protection.
- Wash clothes separately from other clothing; rinse washer thoroughly.
- Operations such as sawing, blowing, tear-out, and spraying may generate fiber concentrations requiring additional respiratory protection. Use the appropriate NIOSH approved respirator.

First Aid Measures:

- **Eye Contact** - Flush eyes with water to remove dust. If symptoms persist, seek medical attention.
- **Skin Contact** - Wash affected areas gently with soap and warm water after handling.

About This Manual

This manual describes the installation of with recommended wiring, piping, and mounting of single-duct, dual-duct, fan-powered, and low-height VAV terminal units, and chilled water sensible coil terminal units.

See also the following reference documents:

- BAS-SVX40*-EN – Wireless Comm IOM
- BAS-SVX55*-EN – Wireless Comm Network Design Best Practices Guide
- BAS-SVX62*-EN – Tracer® UC210 Programmable Variable-Air-Volume (VAV) Box Controller
- VAV-SVX07*-EN – Tracer® UC400 Programmable BACnet® Controller for VAV Units
- VAV-SVP01*-EN – VAV VV550 LonTalk® Controller
- VAV-SVX01*-EN – VAV-UCM 4.2 IOM

Receiving and Handling

These units are shipped completely assembled with the exceptions of outlet duct temperature sensors on non-VCEF products, water valves, and accessories. Upon receiving the equipment, complete the following:

- Locate the nameplate and refer to the model and sales order number and check that the correct units have been delivered.
- Inspect the control enclosures and air valve casing for dents or punctures.
- Verify that all options have been included, such as filters, controls, heating coils, water valves, etc. Also check that the unit voltages agree with the building parameters.
- Manually rotate fan (if applicable) to assure that there are no obstructions within the housing.
- Claims for in-transit damage must be filed immediately with the delivery carrier.
- For hot water reheat units, check the coil fins and make sure that coils are not damaged.
- Locate and verify that the correct zone sensors are with the order. These will be marked with an orange "Accessories Enclosed" label. Store in a secure location until needed. Accessories lost at the job site are NOT covered by the Trane warranty.
- If a discrepancy occurs between what was ordered and what is received, contact you local Trane representative immediately.
- Read appropriate section in this manual for installation procedures prior to starting equipment.

Upon receiving the equipment, please inspect each unit and components for external or internal damage. Refer to the bill of lading to insure all equipment and accessories have been received. Contact your local Trane sales representative and notify the trucking



Introduction

company immediately of any short ship or damaged equipment.

Read this manual thoroughly before operating or servicing this unit.

Copyright

This document and the information in it are the property of Trane, and may not be used or reproduced in whole or in part without written permission. Trane reserves the right to revise this publication at any time,

and to make changes to its content without obligation to notify any person of such revision or change.

Trademarks

All trademarks referenced in this document are the trademarks of their respective owners.

Revision History

Updated the Electrically Commutated Motor section in the Unit Setup chapter.



Table of Contents

Model Numbers	6	Chilled Water Sensible Cooling Terminal Units Moisture Sensor Installation	27
Single-Duct VAV Units	6	Unit Accessibility	27
Dual-Duct VAV Units	10	Clearances	27
Fan-Powered VAV Units Model Number Descriptions	11	Mounting Actuator	27
Chilled Water Sensible Cooling Terminal Units	14	Stand-alone Units	28
Unit Information	16	Stand-alone UCM 4.2	28
Single Duct VAV Units	16	Stand-alone VV550 LonTalk Control	28
Typical Single Duct VAV Units	16	Stand-alone UC400	28
Dual-Duct VAV Units	17	Stand-alone UC210, Symbio 210, and Symbio 210e	28
Fan-Powered/Fan-Powered Low-Height VAV Units	17	Bottom Access	28
Typical Fan-powered Units	17	Weights	29
Chilled Water Sensible Cooling Terminal Units	18	Unit Setup	33
Unit Installation	20	Fan Motor Amperage	33
Single-Duct VAV Units	20	Adjusting the SCR Motor Speed Control	33
Dual-Duct VAV Units	20	Electrically Commutated Motor (ECM)	34
Fan-Powered VAV Units and Chilled Water Sensible Cooling Terminal Units	21	Wiring Diagrams	39
Bracket Locations – Fan Powered	21	Wiring – Electric Heater Control Box	40
Bracket Locations Chilled Water Sensible Cooling Terminal Units	25	Control Box Wiring	53
Duct Connections	25	Maintenance	61
Water Coil Connections	25	Motors	61
Discharge Duct Temperature Sensor Installation	26	Fan Wheel	61
Electronic Duct Temperature Sensor Installation	26	Filter	61
		Filter Change Out	61
		Water Coil	61
		Fan Motor Replacement	61
		SCR Assembly	62



Model Numbers

Single-Duct VAV Units

Digit 1, 2— Unit Type

VC = VariTrane™ Single—Duct

Digit 3— Reheat

C = Cooling Only
E = Electric Heat
W = Hot Water Heat

Digit 4 — Development Sequence

F = Sixth

Digit 5, 6 — Primary Air Valve

04 = 4" inlet (225 cfm)
05 = 5" inlet (350 cfm)
06 = 6" inlet (500 cfm)
08 = 8" inlet (900 cfm)
10 = 10" inlet (1400 cfm)
12 = 12" inlet (2000 cfm)
14 = 14" inlet (3000 cfm)
16 = 16" inlet (4000 cfm)
24 = 24" x 16" inlet (8000 cfm)

Digit 7, 8, 9— Not Used

000 = N/A

Digit 10, 11— Design Sequence

M0 = New Hot Water Coil

Digit 12, 13, 14, 15 — Controls

DD00 = Trane Actuator Only and Enclosure
DD01 = UCM4 Cooling Only Control
DD02 = UCM4 N.C. On/Off Hot Water
DD03 = UCM4 Prop Hot Water
DD04 = UCM4 Staged On/Off Elec Heat
DD05 = UCM4 Pulse Width MOD Elec Heat
DD07 = UCM4 N.O. On/Off Hot Water
DD11 = VV550 DDC- Controller, Cool Only
DD12 = VV550 DDC- Ctrl to operate N.C. On/Off Water Valve
DD13 = VV550 DDC- Ctrl to operate Prop Water Valve
DD14 = VV550 DDC- Ctrl On/Off Elec Heat
DD15 = VV550 DDC- Ctrl w/Pulse Width Modulation
DD16 = VV550 DDC- Controller Ventilation Flow
DD17 = VV550 DDC- Ctrl to Operate N.O. On/Off Water Valve
DD19 = VV550 DDC- Controller with Flow Tracking
DD20 = VV550 DDC- Vent Flow Control I to Operate N.C. Water Valve
DD21 = VV550 DDC- Vent Flow w/ On/Off Elec Heat

Digit 12, 13, 14, 15 — Controls (continued)

DD22 = VV550 DDC- Vent Flow control to operate prop water valve
DD23 = VV550 DDC- Basic plus- Local (Electric heat- PWM) Remote
DD24 = VV550 DDC- Basic plus- Local (Water heat- Modulating)
DD25 = VV550 DDC- Basic plus- Local (Water heat- Modulating) Remote (Water- N.O. 2-position)
DD26 = VV550 DDC- Basic plus- Local (Water heat- N.O. 2-position) Remote (Water- Modulating)
DD27 = VV550 DDC- Basic plus- Local (Water heat- N.C. 2-position) Remote (Water- Modulating)
DD28 = VV550 DDC- Basic plus- Local (Water heat- N.O. 2-position) Remote (Water- N.O. 2-position)
DD29 = VV550 DDC- Basic plus- Local (Water heat- N.C. 2-position) Remote (Water- NC 2-position)
DD30 = VV550 DDC- Basic plus- Local (Water heat- N.O. 2-position) Remote (Water- N.C. 2-position)
DD31 = VV550 DDC- Basic plus- Local (Water heat- N.C. 2-position) Remote (Water- N.O. 2-position)
DD32 = VV550 DDC- Basic plus- Local (Electric heat- Staged) Remote (Staged EH)
DD33 = VV550 DDC- Vent Flow control to operate N.O. On/Off water valve
DD41 = UC400 DDC- Basic (No water or electric heat)
DD42 = UC400 DDC- Basic (Water heat- N.C. 2-position)
DD43 = UC400 DDC- Basic (Water heat- Modulating)
DD44 = UC400 DDC- Basic (Electric heat- Staged)
DD45 = UC400 DDC- Basic (Electric heat- PWM)
DD46 = UC400 DDC- Ventilation flow-cooling only
DD47 = UC400 DDC- Basic (Water heat- N.O. 2-position)
DD49 = UC400 DDC- Flow Tracking (Cooling only)
DD50 = UC400 DDC- Ventilation Flow (Water heat- N. C. 2-position)
DD51 = UC400 DDC- Ventilation Flow (Electric heat- Staged)
DD52 = UC400 DDC- Ventilation Flow (Water heat- Modulating)
DD53 = UC400 DDC- Basic plus- Local (Electric heat- PWM) Remote (Staged EH)
DD54 = UC400 DDC- Basic plus- Local (Water heat- Modulating) Remote (Water- N.C. 2-position)
DD55 = UC400 DDC- Basic plus Local (Water heat- Modulating) Remote (Water- N.O. 2-position)

Digit 12, 13, 14, 15 — Controls (continued)

DD56 = UC400 Basic plus - Local (Water heat - N.O. 2-position) Remote (Water - Modulating)
DD57 = UC400 DDC- Basic plus- Local (Water heat- N.C. 2-position) Remote (Water- Modulating)
DD58 = UC400 DDC- Basic plus- Local (Water heat- N.O. 2-position) Remote (Water- N.O. 2-position)
DD59 = UC400 DDC- Basic plus- Local (Water heat- N.C. 2-position) Remote (Water- N.C. 2-position)
DD60 = UC400 DDC- Basic plus- Local (Water heat- N.O. 2-position) Remote (Water- N.C. 2-position)
DD61 = UC400 DDC- Basic plus- Local (Water heat- N.C. 2-position) Remote (Water- N.O. 2-position)
DD62 = UC400 DDC- Basic plus- Local (Electric heat- Staged) Remote (Staged EH)
DD63 = UC400 DDC- Ventilation Flow (Water heat- N.O. 2-position)
DD65 = UC400 Basic (Electric Heat Modulating SCR)
DD66 = UC400 Basic plus- Local (Electric heat-Modulating SCR) Remote (Staged EH)
DD67 = UC400 Ventilation Flow (Electric heat- Modulating SCR)
DD71 = UC210 DDC- Basic (No water or electric heat)
DD72 = UC210 DDC- Basic (Water heat- N.C. 2-position)
DD73 = UC210 DDC- Basic (Water heat- Modulating)
DD74 = UC210 DDC- Basic (Electric heat- Staged)
DD75 = UC210 DDC- Basic (Electric heat- PWM)
DD76 = UC210 DDC Ventilation flow- cooling only
DD77 = UC210 DDC- Basic (Water heat- N.O. 2-position)
DD79 = UC210 DDC- Flow Tracking (Cooling only)
DD80 = UC210 DDC- Ventilation Flow (Water heat- N.C. 2-position)
DD81 = UC210 DDC- Ventilation Flow (Electric heat- Staged)
DD82 = UC210 DDC- Ventilation Flow (Water heat- Modulating)
DD83 = UC210 DDC- Basic plus- Local (Electric heat- PWM) Remote (Staged EH)
DD84 = UC210 DDC- Basic plus- Local (Water heat- Modulating) Remote (Water- N.C. 2-position)
DD85 = UC210 DDC- Basic plus- Local (Water heat- Modulating) Remote (Water- N.O. 2-position)
DD86 = UC210 DDC- Basic plus- Local (Water heat- N.O. 2-position) Remote (Water- Modulating)

Digit 12, 13, 14, 15 — Controls (continued)

DD87 = UC210 DDC- Basic plus- Local (Water heat- N.C. 2-position) Remote (Water- Modulating)
DD88 = UC210 DDC- Basic plus- Local (Water heat- N.O. 2-position) Remote (Water- N.O. 2-position)
DD89 = UC210 DDC- Basic plus- Local (Water heat- N.C. 2-position) Remote (Water- N.C. 2-position)
DD90 = UC210 DDC- Basic plus- Local (Water heat- N.O. 2-position) Remote (Water- N.C. 2-position)
DD91 = UC210 DDC- Basic plus- Local (Water heat- N.C. 2-position) Remote (Water- N.O. 2-position)
DD92 = UC210 DDC- Basic plus- Local (Electric heat- Staged) Remote (Staged EH)
DD93 = UC210 Ventilation Flow (Water heat- N.O. 2-position)
DD95 = UC210 Basic (Electric Heat Modulating SCR)
DD96 = UC210 Basic plus- Local (Electric heat-Modulating SCR) Remote (Staged EH)
DD97 = UC210 Ventilation Flow (Electric heat-Modulating SCR)
ENCL = Shaft Only in Enclosure
FM00 = Other Actuator and Control
FM01 = Trane Supplied Actuator, Other Ctrl
N.C. = Normally-Closed
N.O. = Normally-Open
FM = Factory Installation of Customer-supplied Controllers
SE71 = Symbio 210e DDC- Basic (Cooling only)
SE72 = Symbio 210e DDC- Basic (Water heat - N.C. 2-position)
SE73 = Symbio 210e DDC- Basic (Water heat-Modulating)
SE74 = Symbio 210e DDC- Basic (Electric heat - Staged)
SE75 = Symbio 210e DDC- Basic (Electric heat - PWM)
SE76 = Symbio 210e DDC- Ventilation flow (no reheat)
SE77 = Symbio 210e DDC- Basic (Water heat - N.O. 2-position)
SE79 = Symbio 210e DDC- Flow track (Cooling only)
SE80 = Symbio 210e DDC- Ventilation flow (N.C. 2-position)
SE81 = Symbio 210e DDC- Ventilation flow (Electric heat - Staged)
SE82 = Symbio 210e DDC- Ventilation flow (Water heat-Modulating)
SE83 = Symbio 210e DDC- Basic plus Local (Electric heat - PWM) Remote (Staged)
SE84 = Symbio 210e DDC- Basic plus Local (Water heat Modulating) Remote (Water N.C. 2-position)
SE85 = Symbio 210e DDC- Basic plus Local (Water heat Modulating) Remote (Water N.O. 2-position)
SE86 = Symbio 210e DDC- Basic plus Local (Water heat - N.O. 2-position) Remote (Water-Modulating)
SE87 = Symbio 210e DDC- Basic plus Local (Water heat - N.C. 2-position) Remote (Water-Modulating)

Digit 12, 13, 14, 15 — Controls (continued)

SE88 = Symbio 210e DDC- Basic plus Local (Water heat - N.O. 2-position) Remote (Water N.O. 2-position)
SE89 = Symbio 210e DDC- Basic plus Local (Water heat - N.C. 2-position) Remote (Water N.C. 2-position)
SE90 = Symbio 210e DDC- Basic plus Local (Water heat - N.O. 2-position) Remote (Water N.C. 2-position)
SE91 = Symbio 210e DDC- Basic plus Local (Water heat - N.C. 2-position) Remote (Water N.O. 2-position)
SE92 = Symbio 210e DDC- Basic plus Local (Electric heat - Staged) Remote (Staged)
SE93 = Symbio 210e DDC- Ventilation flow (water heat - N.O. 2-position)
SE95 = Symbio 210e DDC- Control with modulating SCR
SE96 = Symbio 210e DDC- Space temp control with local SCR and remote stage electric heat
SE97 = Symbio 210e DDC- Vent flow with SCR electric heat
SY71 = Symbio 210 DDC- Basic (Cooling only)
SY72 = Symbio 210 DDC- Basic (Water heat - N.C. 2-position)
SY73 = Symbio 210 DDC- Basic (Water heat-Modulating)
SY74 = Symbio 210 DDC- Basic (Electric heat - Staged)
SY75 = Symbio 210 DDC- Basic (Electric heat - PWM)
SY76 = Symbio 210 DDC- Ventilation flow (no reheat)
SY77 = Symbio 210 DDC- Basic (Water heat - N.O. 2-position)
SY79 = Symbio 210 DDC- Flow track (Cooling only)
SY80 = Symbio 210 DDC- Ventilation flow (N.C. 2-position)
SY81 = Symbio 210 DDC- Ventilation flow (Electric heat - Staged)
SY82 = Symbio 210 DDC- Ventilation flow (Water heat-Modulating)
SY83 = Symbio 210 DDC- Basic plus Local (Electric heat - PWM) Remote (Staged)
SY84 = Symbio 210 DDC- Basic plus Local (Water heat Modulating) Remote (Water N.C. 2-position)
SY85 = Symbio 210 DDC- Basic plus Local (Water heat Modulating) Remote (Water N.O. 2-position)
SY86 = Symbio 210 DDC- Basic plus Local (Water heat - N.O. 2-position) Remote (Water-Modulating)
SY87 = Symbio 210 DDC- Basic plus Local (Water heat - N.C. 2-position) Remote (Water-Modulating)
SY88 = Symbio 210 DDC- Basic plus Local (Water heat - N.O. 2-position) Remote (Water N.O. 2-position)
SY89 = Symbio 210 DDC- Basic plus Local (Water heat - N.C. 2-position) Remote (Water N.C. 2-position)
SY90 = Symbio 210 DDC- Basic plus Local (Water heat - N.O. 2-position) Remote (Water N.C. 2-position)

Digit 12, 13, 14, 15 — Controls (continued)

SY91 = Symbio 210 DDC- Basic plus Local (Water heat - N.C. 2-position) Remote (Water N.O. 2-position)
SY92 = Symbio 210 DDC- Basic plus Local (Electric heat - Staged) Remote (Staged)
SY93 = Symbio 210 DDC- Ventilation flow (Water heat - N.O. 2-position)
SY95 = Symbio 210 DDC- Control with modulating SCR
SY96 = Symbio 210 DDC- Space temp control with local SCR and remote stage electric heat
SY97 = Symbio 210 DDC- Vent flow with SCR electric heat

Digit 16 — Insulation

A = 1/2-in. Matte-faced
B = 1-in Matte-faced
D = 1-in Foil-faced
F = 1-in Double Wall
G = 3/8-in Closed-cell

Digit 17, 18— Not Used

00 = Not Applicable

Digit 19— Outlet Plenum (Slip-and-Drive Connection)

0 = None
A = 1 Outlet RH
B = 1 Outlet END
C = 1 Outlets, LH
D = 2 Outlets, 1RH, 1END
E = 2 Outlets, 1LH, 1END
F = 2 Outlets, 1RH, 1LH
H = 3 Outlets, 1LH, 1RH, 1END
J = 4 Outlets, 1LH, 1RH, 2END

Note: See unit drawings for outlet sizes/damper information.

Digit 20— Not Used

0 = Not Applicable

Digit 21— Water Coil

0 = None
1 = 1 Row
2 = 2 Row
3 = 3 Row
4 = 4 Row
A = 1 Row Premium
B = 2 Row Premium
C = 3 Row Premium
D = 4 Row Premium



Model Numbers

Digit 22— Electrical Connections

F = Able to Flip for LH/RH Connections (VCEF Only)
L = Left, Airflow hits in face
R = Right, Airflow hits in face
O = Opposite side connection, coil and control (VCWF Only)

Note: VCCF/VCWF can be flipped in field for opposite connections.

Digit 23— Transformer

0 = None
1 = 120/24V, 50 VA
2 = 208/24V, 50 VA
3 = 240/24V, 50 VA
4 = 277/24V, 50 VA
5 = 480/24V, 50 VA
6 = 347/24V, 50 VA
7 = 380/24V, 50 VA
8 = 575/24V, 50 VA

Note: For VCEF units with transformers the VA depends on the staging, control, and contactor type (ranges are 50 VA or 75 VA)

Digit 24 — Disconnect Switch

0 = None
W = With

Note: VCCF/VCWF— toggle disconnect. VCEF-door interlocking power disconnect.

Digit 25 — Power Fuse

0 = None
W = With

Digit 26 — Electric Heat Voltage

0 = None
A = 208/60/1
B = 208/60/3
C = 240/60/1
D = 277/60/1
E = 480/60/1
F = 480/60/3
G = 347/60/1
H = 575/60/3
J = 380/50/3
K = 120/60/1

Digit 27, 28, 29 — Electric Heat kW

000 = None
010 = 1.0 kW
015 = 1.5 kW
460 = 46.0 kW

Notes:

- 0.5 to 8.0 kW in 1/2 kW increments
- 8.0 to 18.0 kW in 1 kW increments
- 18.0 to 46.0 kW in 2 kW increments

Digit 30 — Electric Heat Stages

0 = None
1 = 1 Stage
2 = 2 Stages Equal
3 = 3 Stages Equal

Digit 31 — Electric Heat Contactors

0 = None
1 = 24V Magnetic
5 = 0–10Vdc SCR Heat; UC400/UC210
6 = 0–10Vdc SCR Heat; FMTD/ENCL/DD00
7 = 24V SSR (Solid State Relay)

Digit 32, 33— Not Used

00 = Not Applicable

Digit 34 — Actuator

0 = Standard
A = Spring Return, Normally Open
B = Spring Return, Normally Closed
C = Belimo™ Actuator
G = Trane Analog Actuator (UC210 or UC400 only)

Digit 35 — Sensor Options

0 = Standard, Wired
3 = Trane Air-Fi® Wireless Communications Interface

Digit 36 — Pre-wired Factory Solutions

0 = None
1 = Factory-mounted DTS
2 = HW Valve Harness
3 = Both DTS/HW Valve Harness
4 = Averaging DTS Factory-installed in Unit (Required UC210/UC400 w/SCR Heat)
5 = Analog HW Valve, field provided
6 = Factory-mounted DTS and HWV Harness

Digit 37 — Integral Attenuator with Cam Lock Bottom Access

0 = None
1 = Attenuator and bottom access - left side controls
2 = Attenuator and bottom access - right side controls
3 = Attenuator and bottom access - left side controls, right side water coil connections
4 = Attenuator and bottom access - right side controls, left side water coil connections

Digit 38 —Piping Package

0 = None
A = 2-Way Automatic Balancing
B = 3-Way Automatic Balancing
C = 2-Way Standard Valve Only, Floating Point Actuator
D = 3-Way Standard Valve Only, Floating Point Actuator
E = 2-Way Standard Valve Piping Package, Floating Point Actuator
F = 3-Way Standard Valve Piping Package, Floating Point Actuator
G = 2-Way Belimo Valve Only, Floating Point Actuator
H = 3-Way Belimo Valve Only, Floating Point Actuator
J = 2-Way Belimo Valve Piping Package, Floating Point Actuator
K = 3-Way Belimo Valve Piping Package, Floating Point Actuator
L = 2-Way Belimo Valve Only, Analog Actuator
M = 3-Way Belimo Valve Only, Analog Actuator
N = 2-Way Belimo Valve Piping Package, Analog Actuator
P = 3-Way Belimo Valve Piping Package, Analog Actuator

Digit 39 — Water Valve

0 = None
1 = Trane HW Valve 0.7 Cv
2 = Trane HW Valve 2.7 Cv
5 = Analog HW Valve, field provided (UC210 or UC400 only)
6 = Trane HW Valve, 1.7 Cv
7 = Trane HW Valve, 5.0 Cv
A = Belimo HW Valve, 0.3 Cv
B = Belimo HW Valve, 0.46 Cv
C = Belimo HW Valve, 0.8 Cv
D = Belimo HW Valve, 1.2 Cv
E = Belimo HW Valve, 1.9 Cv
F = Belimo HW Valve, 3.0 Cv
G = Belimo HW Valve, 4.7 Cv

Digit 40 – Flow Rate

0	= None
A	= 0.5 gpm, 0.03 l/s
B	= 1.0 gpm, 0.06 l/s
C	= 1.5 gpm, 0.09 l/s
D	= 2.0 gpm, 0.13 l/s
E	= 2.5 gpm, 0.16 l/s
F	= 3.0 gpm, 0.19 l/s
G	= 3.5 gpm, 0.22 l/s
H	= 4.0 gpm, 0.25 l/s
J	= 4.5 gpm, 0.28 l/s
K	= 5.0 gpm, 0.31 l/s
L	= 5.5 gpm, 0.35 l/s
M	= 6.0 gpm, 0.38 l/s
N	= 6.5 gpm, 0.41 l/s
P	= 7.0 gpm, 0.44 l/s
Q	= 7.5 gpm, 0.47 l/s
R	= 8.0 gpm, 0.50 l/s
S	= 9.0 gpm, 0.57 l/s
T	= 10.0 gpm, 0.63 l/s
U	= 11.0 gpm, 0.69 l/s
V	= 12.0 gpm, 0.76 l/s

Digit 41 – Air Leakage Class

0	= Standard Air Leakage
1	= Certified Ultra-Low Air Leakage



Model Numbers

Dual-Duct VAV Units

Digit 1, 2, 3— Unit Type

VDD = VariTrane™ Dual—Duct

Digit 4 — Development Sequence

F = Sixth

Digit 5, 6 — Primary Air Valve

05 = 5" inlet (350 cfm)
06 = 6" inlet (500 cfm)
08 = 8" inlet (900 cfm)
10 = 10" inlet (1400 cfm)
12 = 12" inlet (2000 cfm)
14 = 14" inlet (3000 cfm)
16 = 16" inlet (4000 cfm)

Digit 7, 8 — Secondary Air Valve

05 = 5" inlet (350 cfm)
06 = 6" inlet (500 cfm)
08 = 8" inlet (900 cfm)
10 = 10" inlet (1400 cfm)
12 = 12" inlet (2000 cfm)
14 = 14" inlet (3000 cfm)
16 = 16" inlet (4000 cfm)

Digit 9— Not Used

0 = Not applicable

Digit 10, 11— Design Sequence

****** = Factory Assigned

Digit 12, 13, 14, 15 — Controls

DD00 = Trane Actuator Only
DD01 = Dual UCM4.2 Cooling Only Control
DD08 = Dual UCM4.2 Constant Volume
DD11 = Dual VV550 DDC, Cooling Only
DD18 = Dual VV550 DDC, Constant Volume
DD41 = UC400 DDC Basic, No Water or Electric Heat
DD48 = UC400 DDC Basic, Constant Volume
FM00 = Other Actuator and Control
FM01 = Trane Supplied Actuator, Other Ctrl

Digit 16 — Insulation

A = 1/2" Matte-faced
B = 1" Matte-faced
D = 1" Foil-faced
F = 1" Double Wall
G = 3/8" Closed-cell

Digit 17— Not Used

0 = Not Applicable

Digit 18— Not Used

0 = Not Applicable

Digit 19 — Outlet Plenum (Slip-and-Drive Connection)

0 = None
A = 1 Outlet RH
B = 1 Outlet END
C = 1 Outlets, LH
D = 2 Outlets, 1RH, 1END
E = 2 Outlets, 1LH, 1END
F = 2 Outlets, 1RH, 1LH
G = 2 Outlets, 2END
H = 3 Outlets, 1LH, 1RH, 1END
J = 4 Outlets, 1LH, 1RH, 2END

Note: See unit drawings for outlet sizes/damper information.

Digit 20— Not Used

0 = Not Applicable

Digit 21— Not Used

0 = Not Applicable

Digit 22— Not Used

0 = Not Applicable

Digit 23 — Transformer

0 = None
1 = 120/24V, 50 VA
2 = 208/24V, 50 VA
3 = 240/24V, 50 VA
4 = 277/24V, 50 VA
5 = 480/24V, 50 VA
6 = 347/24V, 50 VA
7 = 575/24V, 50 VA

Digit 24— Disconnect Switch

0 = None
W = With Toggle

Digit 25 — Power Fuse

0 = None
W = With

Digit 26 — Not Used

0 = Not Applicable

Digit 27 — Not Used

0 = Not Applicable

Digit 28 — Not Used

0 = Not Applicable

Digit 29 — Not Used

0 = Not Applicable

Digit 30— Not Used

0 = Not Applicable

Digit 31 — Not Used

0 = Not Applicable

Digit 32 — Not Used

0 = Not Applicable

Digit 33 — Special Options

0 = None
X = Varies, Factory Assigned

Digit 34 — Actuator

0 = Standard
A = Belimo™ Actuator
B = Trane Analog Actuator (UC400 only)

Digit 35 — Wireless Sensor

0 = Sensor/Receiver Standard
3 = Trane Air-Fi® Wireless Communication Interface

Note: All sensors selected in accessories.

Digit 36 — Duct Temperature Sensor

0 = None
1 = With Duct Temperature Sensor

Fan-Powered VAV Units Model Number Descriptions

Digit 1, 2— Unit Type

VP = VariTrane™ Fan-Powered Parallel
VS = VariTrane™ Fan-Powered Series
LP = VariTrane™ Fan-Powered Low Height Parallel
LS = VariTrane™ Fan-Powered Low Height Series

Digit 3— Reheat

C = Cooling Only
E = Electric Heat
W = Hot Water Heat

Digit 4 — Development Sequence

F = Sixth

Digit 5, 6 — Primary Air Valve

04 = 4" inlet (225 cfm)
05 = 5" inlet (350 cfm)
06 = 6" inlet (500 cfm)
08 = 8" inlet (900 cfm)
10 = 10" inlet (1400 cfm)
12 = 12" inlet (2000 cfm)
14 = 14" inlet (3000 cfm)
16 = 16" inlet (4000 cfm)
RT = 8" x 14" inlet (1800 cfm)

Note: 10, 12, 14, and 16 not available on low height units.

Digit 7, 8— Secondary Air Valve Used

00 = N/A

Digit 9 — Fan

A = DS02 Fan (1300 nom cfm)
B = DS03 Fan (1950 nom cfm)
C = PS02 Fan (1160 nom cfm)
P = 02SQ Fan (500 nom cfm)
Q = 03SQ Fan (1100 nom cfm)
R = 04SQ Fan (1350 nom cfm)
S = 05SQ Fan (1550 nom cfm)
T = 06SQ Fan (1850 nom cfm)
U = 07SQ Fan (2000 nom cfm)

Digit 10, 11— Design Sequence

****** = Factory Assigned

Digit 12, 13, 14, 15 — Controls

DD01 = Cooling Only Control
DD02 = N.C. On/Off Hot Water
DD03 = Prop Hot Water
DD04 = Staged On/Off Elec Heat
DD05 = Pulse Width Mod of Elect Heat
DD07 = N.O. On/Off Hot Water
DD11 = VV550 DDC- Controller, Cooling Only
DD12 = VV550 DDC- Control w/N.C. On/Off HW Valve
DD13 = VV550 DDC- Control w/Prop. HW Valve
DD14 = VV550 DDC- Control On/Off Electric Heat
DD15 = VVV550 DDC- Control w/Pulse Width Modulation
DD17 = VVV550 DDC- Control w/N.O On/Off HW Valve
DD41 = UC400 DDC- Basic (No water or electric heat)
DD42 = UC400 DDC- Basic (Water heat- N.C. 2-position)
DD43 = UC400 DDC- Basic (Water heat- Modulating)
DD44 = UC400 DDC- Basic (Electric heat- Staged)
DD45 = UC400 DDC- Basic (Electric heat- PWM)
DD47 = UC400 DDC- Basic (Water heat- N.O. 2-position)
DD53 = UC400 DDC- Basic plus- Local (Electric heat- PWM) Remote (Staged EH)
DD58 = UC400 DDC- Basic plus- Local (Water heat- Modulating) Remote (Water- N.O. 2-position)
DD59 = UC400 DDC- Basic plus Local (Water heat- Modulating) Remote (Water- N.C. 2-position)
DD60 = UC400 DDC- Basic Plus Local (Water Heat- N.O. 2-position) Remote Water- N.C. 2-position)
DD61 = UC400 DDC- Basic plus- Local (Water heat- N.C. 2-position) Remote (Water- N.O. 2-position)
DD62 = UC400 DDC- Basic plus- Local (Electric heat- Staged) Remote (Staged EH)
DD65 = UC400 Basic (Electric Heat Modulating SCR)
DD66 = UC400 Basic plus- Local (Electric heat-Modulating SCR) Remote (Staged EH)

Digit 12, 13, 14, 15 — Controls (continued)

DD71 = UC210 DDC- Basic (No water or electric heat)
DD72 = UC210 DDC- Basic (Water heat- N.C. 2-position)
DD73 = UC400 DDC- Basic (Water heat- Modulating)
DD74 = UC210 DDC- Basic (Electric heat- Staged)
DD75 = UC210 DDC- Basic (Electric heat- PWM)
DD77 = UC210 DDC- Basic (Water heat- N.O. 2-position)
DD83 = UC210 DDC- Basic plus- Local (Electric heat- PWM) Remote (Staged EH)
DD84 = UC210 DDC- Basic plus- Local (Water heat- Modulating) Remote (Water- N.C. 2-position)
DD85 = UC210 DDC- Basic plus- Local (Water heat- Modulating) Remote (Water- N.O. 2-position)
DD86 = UC210 DDC- Basic plus- Local (Water heat- N.O. 2-position) Remote (Water- Modulating)
DD87 = UC210 DDC- Basic plus- Local (Water heat- N.C. 2-position) Remote (Water- Modulating)
DD88 = UC210 DDC- Basic plus- Local (Water heat- N.O. 2-position) Remote (Water- N.O. 2-position)
DD89 = UC210 DDC- Basic plus- Local (Water heat- N.C. 2-position) Remote (Water- N.C. 2-position)
DD90 = UC210 DDC- Basic plus- Local (Water heat- N.O. 2-position) Remote (Water- N.C. 2-position)
DD91 = UC210 DDC- Basic plus- Local (Water heat- N.C. 2-position) Remote (Water- N.O. 2-position)
DD92 = UC210 DDC- Basic plus- Local (Electric heat- Staged) Remote (Staged)
DD95 = UC210 Basic (Electric Heat Modulating SCR)
DD96 = UC210 Basic plus- Local (Electric heat-Modulating SCR) Remote (Staged EH)
DD00 = Trane Actuator Only
ENCL = Shaft Only in Enclosure
FM00 = Other Actuator and Control
FM01 = Trane Supplied Actuator, Other Ctrl
SY71 = Symbio 210 DDC - Basic (Cooling only)
SY72 = Symbio 210 DDC - Basic (Water heat- N.C.- 2 position)
SY73 = Symbio 210 DDC - Basic (Water heat- Modulating)
SY74 = Symbio 210 DDC - Basic (Electric heat-staged)
SY75 = Symbio 210 DDC - Basic (Electric heat-PWM)



Model Numbers

Digit 12, 13, 14, 15 — Controls (continued)

SY77 = Symbio 210 DDC -Basic (Water heat -N.O.- 2 position)
SY83 = Symbio 210 DDC- Basic plus- Local (Electric heat- PWM) Remote (Staged)
SY84 = Symbio 210 DDC- Basic plus- Local (Water heat- Modulating) Remote (Water- N.C. 2-position)
SY85 = Symbio 210 DDC- Basic plus- Local (Water heat- Modulating) Remote (Water- N.O. 2-position)
SY86 = Symbio 210 DDC- Basic plus- Local (Water heat- N.O. 2-position) Remote (Water- Modulating)
SY87 = Symbio 210 DDC- Basic plus- Local (Water heat- N.C. 2-position) Remote (Water- Modulating)
SY88 = Symbio 210 DDC- Basic plus- Local (Water heat- N.O. 2-position) Remote (Water- N.O. 2-position)
SY89 = Symbio 210 DDC- Basic plus- Local (Water heat- N.C. 2-position) Remote (Water- N.C. 2-position)
SY90 = Symbio 210 DDC- Basic plus- Local (Water heat- N.O. 2-position) Remote (Water- N.C. 2-position)
SY91 = Symbio 210 DDC- Basic plus- Local (Water heat- N.C. 2-position) Remote (Water- N.O. 2-position)
SY92 = Symbio 210 DDC- Basic plus- Local (Electric heat- Staged) Remote (Staged)
SY95 = Symbio 210 DDC - Control with Modulating SCR
SY96 = Symbio 210 DDC - Space Temp Control with Local SCR and Remote Staged Electric heat
SE71 = Symbio 210e DDC - Basic (Cooling only)
SE72 = Symbio 210e DDC - Basic (Water heat- N.C.- 2 position)
SE73 = Symbio 210e DDC - Basic (Water heat- Modulating)
SE74 = Symbio 210e DDC - Basic (Electric heat-staged)
SE75 = Symbio 210e DDC - Basic (Electric heat-PWM)
SE77 = Symbio 210e DDC -Basic (Water heat -N.O.- 2 position)
SE83 = Symbio 210 DDC- Basic plus- Local (Electric heat- PWM) Remote (Staged)
SE84 = Symbio 210e DDC- Basic plus- Local (Water heat- Modulating) Remote (Water- N.C. 2-position)
SE85 = Symbio 210e DDC- Basic plus- Local (Water heat- Modulating) Remote (Water- N.O. 2-position)

Digit 12, 13, 14, 15 — Controls (continued)

SE86 = Symbio 210e DDC- Basic plus- Local (Water heat- N.O. 2-position) Remote (Water- Modulating)
SE87 = Symbio 210e DDC- Basic plus- Local (Water heat- N.C. 2-position) Remote (Water- Modulating)
SE88 = Symbio 210e DDC- Basic plus- Local (Water heat- N.O. 2-position) Remote (Water- N.O. 2-position)
SE89 = Symbio 210e DDC- Basic plus- Local (Water heat- N.C. 2-position) Remote (Water- N.C. 2-position)
SE90 = Symbio 210e DDC- Basic plus- Local (Water heat- N.O. 2-position) Remote (Water- N.C. 2-position)
SE91 = Symbio 210e DDC- Basic plus- Local (Water heat- N.C. 2-position) Remote (Water- N.O. 2-position)
SE92 = Symbio 210e DDC- Basic plus- Local (Electric heat- Staged) Remote (Staged)
SE95 = Symbio 210e DDC - Control with Modulating SCR
SE96 = Symbio 210e DDC - Space Temp Control with Local SCR and Remote Staged Electric heat

Digit 16 — Insulation

A = 1/2" Matte-faced
B = 1" Matte-faced
D = 1" Foil-faced
F = 1" Double Wall
G = 3/8" Closed-cell

Digit 17— Motor Type

D = PSC Motor
E = High-efficiency Electronically Commutated Motor (ECM)
F = Variable Speed High-efficiency Electronically Commutated Motor (ECV)

Digit 18— Motor Voltage

1 = 115/60/1
2 = 277/60/1
3 = 347/60/1
4 = 208/60/1
5 = 230/50/1

Digit 19— Outlet Connection

1 = Flanged
2 = Slip-and-Drive Connection

Digit 20— Attenuator

0 = None
B = Suppressor
T = Thinline Suppressor

Digit 21— Water Coil

0 = None
1 = 1 Row, Plenum Inlet Installed RH
2 = 2 Row, Plenum Inlet Installed RH
3 = 1 Row, Discharge Installed LH
4 = 1 Row, Discharge Installed RH
5 = 2 Row, Discharge Installed LH
6 = 2 Row, Discharge Installed RH
A = 1 Row Premium, Water Coil Inlet
B = 2 Row Premium, Water Coil Inlet
C = 1 Row Premium, Hot Coil on Discharge LH
D = 1 Row Premium, Hot Coil on Discharge RH
E = 2 Row Premium, Hot Coil on Discharge LH
F = 2 Row Premium, Hot Coil on Discharge RH

Digit 22— Electrical Connections

F = Flippable Left and Right Hand
L = Left, Airflow hits in face
R = Right, Airflow hits in face
W = Narrow Corridor LH, High Voltage, Inlet Facing
X = Narrow Corridor RH, High Voltage, Inlet Facing

Note: Digits *W* and *X*, fan-powered series only.

Digit 23— Transformer

0 = Not Applicable

Digit 24 — Disconnect Switch

0 = None
W = With

Note: Electric reheat w/door interlocking power disconnect, cooling only and water reheat w/toggle disconnect.

Digit 25 — Power Fuse

0 = None
W = With

Digit 26 — Electric Heat Voltage

0 = None
A = 208/60/1
B = 208/60/3
C = 240/60/1
D = 277/60/1
E = 480/60/1
F = 480/60/3
G = 347/60/1
H = 575/60/3
J = 380/50/3
K = 120/60/1

Note: Digit *K* not available with low height.

Digit 27, 28, 29— Electric Heat kW

000 = None
010 = 1.0 kW
015 = 1.5 kW
460 = 46.0 kW

Notes:

- 0.5 to 8.0 kW in 1/2 kW increments
- 8.0 to 18.0 kW in 1 kW increments
- 18.0 to 46.0 kW in 2 kW increments

Digit 30 — Electric Heat Stages

0 = None
1 = 1 Stage
2 = 2 Stages Equal
3 = 3 Stages Equal

Note: Digit 3 not available with low height.

Digit 31 — Electric Heat Contactors

0 = None
1 = 24V Magnetic
5 = 0-10 Vdc SCR Heat; UC400
6 = 0-10 Vdc SCR Heat; FMTD/ENCL/DD00
7 = 24V SSR (Solid State Relay)

Notes: SCR cannot be selected with the following:

- kW > 10, 208V, 3Ph, Low Height
- kW > 22, 480V, 3Ph, Low Height
- Voltage = 575V

Digit 32— Air Switch

0 = Not Applicable
W = With

Digit 33— Not Used

0 = Not Applicable

Digit 34 — Actuator

0 = Standard
A = Belimo™ Actuator
G = Trane Analog Actuator (UC210 or UC400 only)

Digit 35 — Wireless Sensors

0 = None
3 = Trane Air-Fi® Wireless Communications Interface

Note: All sensors selected in accessories.

Digit 36 — Pre-wired Factory Solutions

0 = None
1 = Factory-mounted DTS
2 = HW Valve Harness
3 = Both DTS/HW Valve Harness

Digit 37 — Bottom Access

0 = None
W = Access Left Side Terminal Unit

Digit 38 — Piping Package

0 = None
A = 2-Way Automatic Balancing
B = 3-Way Automatic Balancing
C = 2-Way Standard Valve Only, Floating Point Actuator
D = 3-Way Standard Valve Only, Floating Point Actuator
E = 2-Way Standard Valve Piping Package, Floating Point Actuator
F = 3-Way Standard Valve Piping Package, Floating Point Actuator
G = 2-Way Belimo Valve Only, Floating Point Actuator
H = 3-Way Belimo Valve Only, Floating Point Actuator
J = 2-Way Belimo Valve Piping Package, Floating Point Actuator
K = 3-Way Belimo Valve Piping Package, Floating Point Actuator
L = 2-Way Belimo Valve Only, Analog Actuator
M = 3-Way Belimo Valve Only, Analog Actuator
N = 2-Way Belimo Valve Piping Package, Analog Actuator
P = 3-Way Belimo Valve Piping Package, Analog Actuator

Digit 39 — Water Valve

0 = None
1 = Trane HW Valve 0.7 Cv
2 = Trane HW Valve 2.7 Cv
5 = Analog HW Valve, Field Provided (UC210 or UC400 only)
6 = Trane HW Valve 1.7 Cv
7 = Trane HW Valve 5.0 Cv
A = Belimo HW Valve, 0.3 Cv
B = Belimo HW Valve, 0.46 Cv
C = Belimo HW Valve, 0.8 Cv
D = Belimo HW Valve, 1.2 Cv
E = Belimo HW Valve, 1.9 Cv
F = Belimo HW Valve, 3.0 Cv
G = Belimo HW Valve, 4.7 Cv

Digit 40 — Flow Rate

0 = None
A = 0.5 gpm, 0.03 l/s
B = 1.0 gpm, 0.06 l/s
C = 1.5 gpm, 0.09 l/s
D = 2.0 gpm, 0.13 l/s
E = 2.5 gpm, 0.16 l/s
F = 3.0 gpm, 0.19 l/s
G = 3.5 gpm, 0.22 l/s
H = 4.0 gpm, 0.25 l/s
J = 4.5 gpm, 0.28 l/s
K = 5.0 gpm, 0.31 l/s
L = 5.5 gpm, 0.35 l/s
M = 6.0 gpm, 0.38 l/s
N = 6.5 gpm, 0.41 l/s
P = 7.0 gpm, 0.44 l/s
Q = 7.5 gpm, 0.47 l/s



Model Numbers

Chilled Water Sensible Cooling Terminal Units

Digit 1, 2— Unit Type

LD = Chilled Water Sensible Cooling Terminal Units

Digit 3— Heating

C = Cooling Only
E = Electric Heat
W = Hot Water Heat

Digit 4 — Development Sequence

F = Sixth

Digit 5, 6 — Primary Air Valve

04 = 4 in. inlet (225 max cfm)
05 = 5 in. inlet (350 max cfm)
06 = 6 in. inlet (500 max cfm)
08 = 8 in. inlet (900 max cfm)
RT = 8x14 in. inlet (1800 max cfm)

Digit 7, 8— Secondary Air Valve

00 = N/A

Digit 9 — Fan

B = DS02 Fan (1300 max cfm)

Digit 10, 11— Design Sequence

****** = Factory Assigned

Digit 12, 13, 14, 15 — Controls

DD00 = Trane Actuator Only
ENCL = Shaft Only in Enclosure
FM00 = Other Actuator and Control
FM01 = Trane Supplied Actuator, Other Control
SC41 = UC400 DDC- Sensible Cooling- Basic (No water or electric heat)
SC43 = UC400 DDC- Sensible Cooling- Basic (Water heat, Modulating)
SC44 = UC400 DDC- Sensible Cooling- Basic (Electric heat- Staged)
SC62 = UC400 DDC- Sensible Cooling- Basic plus Local (Electric heat- Staged), Remote (Staged)
SC65 = UC400 DDC- Sensible Cooling- Basic (Electric Heat Modulating SCR)
SC66 = UC400 DDC- Sensible Cooling- Basic plus Local (Electric heat- Modulating SCR) Remote (Staged)

Digit 16 — Insulation

A = 1/2" Matte-faced
B = 1" Matte-faced
D = 1" Foil-faced
F = 1" Double Wall
G = 3/8" Closed-cell

Digit 17 — Motor Type

E = High-efficiency Motor (ECM)
F = Variable Speed High-efficiency Electronically Commutated Motor (ECV)

Digit 18 — Motor Voltage

1 = 115/60/1
2 = 277/60/1

Digit 19 — Outlet Connection

1 = Flanged
2 = Slip-and-Drive Connection

Digit 20 — Attenuator

0 = No Attenuator

Digit 21 — Water Coil

0 = None
3 = 1 Row, Discharge Installed, LH
4 = 1 Row, Discharge Installed, RH
5 = 2 Row, Discharge Installed, LH
6 = 2 Row, Discharge Installed, RH
C = 1 Row Premium, Hot Coil on Discharge, LH
D = 1 Row Premium, Hot Coil on Discharge, RH
E = 2 Row Premium, Hot Coil on Discharge, LH
F = 2 Row Premium, Hot Coil on Discharge, RH

Digit 22 — Control, Heat Connections

F = Flippable Left and Right Hand

Digit 23 — Unit Filter

0 = Construction Throw-away Filter
8 = MERV 8 Filter

Digit 24 — Disconnect Switch

0 = None
W = With

Digit 25 — Power Fuse

0 = None
W = With

Digit 26 — Electric Heat Voltage

0 = None
A = 208/60/1
B = 208/60/3
C = 240/60/1
D = 277/60/1
E = 480/60/1
F = 480/60/3

Digit 27, 28, 29 — Electric Heat kW

000 = None
005 = 0.5 kW
010 = 1.0 kW
015 = 1.5 kW
200 = 20.0 kW

Notes:

- 0.5 to 8.0 kW in 1/2 kW increments
- 8.0 to 18.0 kW in 1 kW increments
- 18.0 to 20.0 kW in 2 kW increments

Digit 30 — Electric Heat Stages

0 = None
1 = 1 Stage
2 = 2 Stages Equal

Digit 31 — Electric Heat Contactors

0 = None
1 = 24V Magnetic
5 = SCR Heat, UC400
6 = SCR Heat, FM00/ENCL/DD00

Digit 32 — Airflow Switch

0 = None
W = With

Digit 33 — Not Used

0 = Not Applicable

Digit 34 — Actuator

0 = Standard
A = Belimo™ Actuator

Digit 35 — Wireless Sensors

0 = None
3 = Air-Fi® Wireless Communications

Note: All sensors selected in accessories.

Digit 36 — Pre-wired Factory Solutions

- 0** = None
- 1** = Discharge Temperature Sensor (DTS)
- 2** = Hot Water (HW) Valve Harness
- 3** = DTS and HW Valve Harness
- 7** = Chilled Water (CW) Valve Harness
- 8** = CW and HW Valve Harness
- B** = DTS with CW Valve Harness
- C** = DTS with CW and HW Valve Harness

Digit 37 — Not Used

- 0** = Not Applicable

Digit 38 — Hot Water Piping Package

- 0** = None
- A** = 2-Way Automatic Balancing
- B** = 3-Way Automatic Balancing
- C** = 2-Way Standard Valve Only, Floating Point Actuator
- D** = 3-Way Standard Valve Only, Floating Point Actuator
- E** = 2-Way Standard Valve Piping Package, Floating Point Actuator
- F** = 3-Way Standard Valve Piping Package, Floating Point Actuator
- G** = 2-Way Belimo Valve Only, Floating Point Actuator
- H** = 3-Way Belimo Valve Only, Floating Point Actuator
- J** = 2-Way Belimo Valve Piping Package, Floating Point Actuator
- K** = 3-Way Belimo Valve Piping Package, Floating Point Actuator
- L** = 2-Way Belimo Valve Only, Analog Actuator
- M** = 3-Way Belimo Valve Only, Analog Actuator
- N** = 2-Way Belimo Valve Piping Package, Analog Actuator
- P** = 3-Way Belimo Valve Piping Package, Analog Actuator

Digit 39 — Hot Water Valve

- 0** = None
- 1** = Trane HW Valve, 0.7 Cv
- 2** = Trane HW Valve, 2.7 Cv
- 5** = Analog, HW Valve, field provided (UC210 or UC400 only)
- 6** = Trane HW Valve, 1.7 Cv
- 7** = Trane HW Valve, 5.0 Cv
- A** = Belimo HW Valve, 0.3 Cv
- B** = Belimo HW Valve, 0.46 Cv
- C** = Belimo HW Valve, 0.8 Cv
- D** = Belimo HW Valve, 1.2 Cv
- E** = Belimo HW Valve, 1.9 Cv
- F** = Belimo HW Valve, 3.0 Cv
- G** = Belimo HW Valve, 4.7 Cv

Digit 40 — Hot Water Flow Rate

- 0** = None (No Flow Rate)
- A** = 0.5 gpm (0.03 L/s)
- B** = 1 gpm (0.06 L/s)
- C** = 1.5 gpm (0.09 L/s)
- D** = 2 gpm (0.13 L/s)
- E** = 2.5 gpm (0.16 L/s)
- F** = 3 gpm (0.19 L/s)
- G** = 3.5 gpm (0.22 L/s)
- H** = 4 gpm (0.25 L/s)
- J** = 4.5 gpm (0.28 L/s)
- K** = 5 gpm (0.32 L/s)
- L** = 5.5 gpm (0.35 L/s)
- M** = 6 gpm (0.38 L/s)
- N** = 6.5 gpm (0.41 L/s)
- P** = 7 gpm (0.44 L/s)
- Q** = 7.5 gpm (0.47 L/s)

Digit 41 — Sensible Cooling Coil

- 2** = 2-Row Standard Cooling Coil
- 4** = 4-Row Standard Cooling Coil
- 6** = 6-Row Standard Cooling Coil

Digit 42 — Chilled Water Coil Connections

- D** = Cooling Coil Connections at Unit Discharge End
- V** = Cooling Coil Connections at Air Valve End

Digit 43 — Chilled Water Piping Package

- 0** = None
- A** = 2-Way Automatic Balancing
- B** = 3-Way Automatic Balancing
- C** = 2-Way Standard Valve Only, Floating Point Actuator
- D** = 3-Way Standard Valve Only, Floating Point Actuator
- E** = 2-Way Standard Valve Piping Package, Floating Point Actuator
- F** = 3-Way Standard Valve Piping Package, Floating Point Actuator
- G** = 2-Way Belimo Valve Only, Floating Point Actuator
- H** = 3-Way Belimo Valve Only, Floating Point Actuator
- J** = 2-Way Belimo Valve Piping Package, Floating Point Actuator
- K** = 3-Way Belimo Valve Piping Package, Floating Point Actuator
- L** = 2-Way Belimo Valve Only, Analog Actuator
- M** = 3-Way Belimo Valve Only, Analog Actuator
- N** = 2-Way Belimo Valve Piping Package, Analog Actuator
- P** = 3-Way Belimo Valve Piping Package, Analog Actuator

Digit 44 — Chilled Water Valve

- 0** = None
- 1** = Trane CW Valve, 0.7 Cv
- 2** = Trane CW Valve, 2.7 Cv
- 5** = Analog CW Valve, Field-Provided (UC400 Only)
- 6** = Trane CW Valve, 1.7 Cv
- 7** = Trane CW Valve, 5.0 Cv
- A** = Belimo CW Valve, 0.3 Cv
- B** = Belimo CW Valve, 0.46 Cv
- C** = Belimo CW Valve, 0.8 Cv
- D** = Belimo CW Valve, 1.2 Cv
- E** = Belimo CW Valve, 1.9 Cv
- F** = Belimo CW Valve, 3.0 Cv
- G** = Belimo CW Valve, 4.7 Cv

Digit 45 — Chilled Water Flow Rate

- 0** = None (No Flow Rate)
- A** = 0.5 gpm (0.03 L/s)
- B** = 1 gpm (0.06 L/s)
- C** = 1.5 gpm (0.09 L/s)
- D** = 2 gpm (0.13 L/s)
- E** = 2.5 gpm (0.16 L/s)
- F** = 3 gpm (0.19 L/s)
- G** = 3.5 gpm (0.22 L/s)
- H** = 4 gpm (0.25 L/s)
- J** = 4.5 gpm (0.28 L/s)
- K** = 5 gpm (0.32 L/s)
- L** = 5.5 gpm (0.35 L/s)
- M** = 6 gpm (0.38 L/s)
- N** = 6.5 gpm (0.41 L/s)
- P** = 7 gpm (0.44 L/s)
- Q** = 7.5 gpm (0.47 L/s)
- R** = 8.0 gpm (0.50 L/s)



Unit Information

Single Duct VAV Units

The basic unit consists of a sheet metal casing with an air valve, which is used to modulate the air being delivered into the occupied zone. The unit is designed to modulate either cooling or heating air between 40°F and 140°F (4.44°C and 60°C). Air enters the air valve through the round or rectangular inlet and exits into the sheet metal casing to be distributed to the zone either through integral round outlets in the casing or through rectangular duct attached to the discharge of the unit.

The basic unit can also be ordered with factory-mounted electric or hot water heating coils attached to the discharge.

These reheat units are used primarily to reheat air-to-zone temperature when the load in the occupied space is low.

Primary air is modulated through the VariTrane™ air valve by rotating the damper blade. All air valves have a round/rectangular inlet for easy fit-up with incoming duct work.

Typical Single Duct VAV Units

Figure 1. Typical single duct unit; VCCF VCWF, VCEF

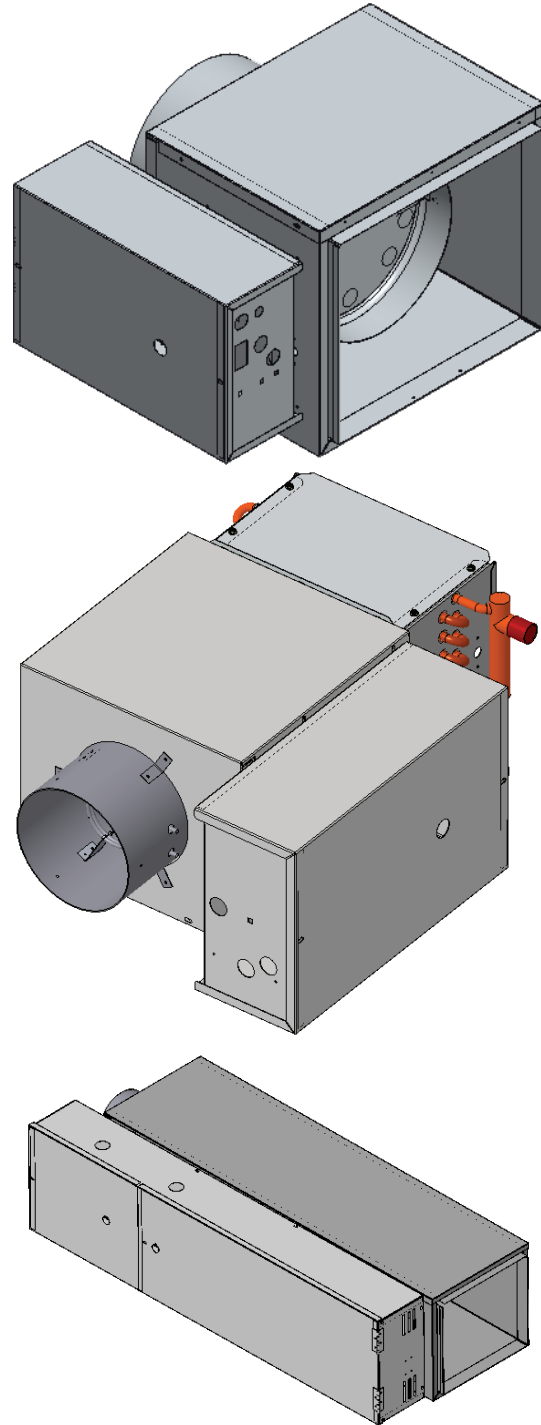

Dual-Duct VAV Units

Dual-duct units provide two air valves: one as heating primary air and the other as cooling primary air. Both discharge into the common outlet, which leads to the zone being controlled. See [Figure 2, p. 17](#).

Units are provided with a slip and drive rectangular duct connection or can be ordered with integral outlet plenum.

Sequencing of hot and cold air valve is dependent on job requirements. One typical control is valves working in conjunction to respond to zone temperature.

When the cooling valve becomes fully closed or reaches a specified valve minimum, the heating valve will begin to modulate or vice versa. The typical result is that air flowing to the zone varies from maximum down to a minimum and back up to maximum as load varies and controls would cause one air valve to close and the other to open.

Another typical application is when the unit provides a constant volume to the zone. When the zone sensor is tied directly to the heating valve, it will modulate the heating valve according to the zone temperature.

When the heating valve is fully closed or there is a call for cooling in the zone, the cooling valve will be at constant supply. As the space becomes too cool, the heating valve will modulate open, decreasing the cooling valve flow. The typical result is that the air flowing into the zone stays at a constant flow whether the unit is heating or cooling.

Factory-installed Trane unit controls available include;

- UC400 — one required per unit
- VV550 — two required per unit
- UCM — two required per unit

Figure 2. Typical dual-duct unit; VDDF

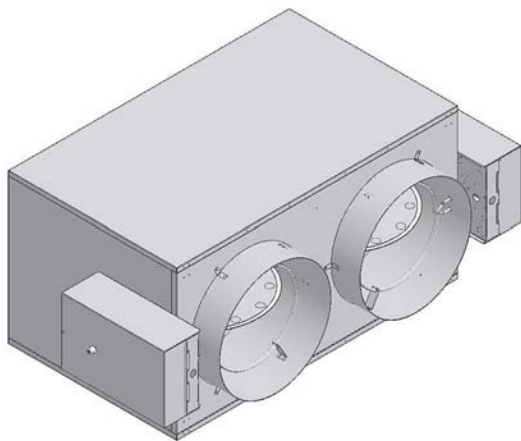

Fan-Powered/Fan-Powered Low-Height VAV Units

VariTrane™ fan-powered and low-height fan-powered units can be either parallel or series, with or without re-heat. Refer to the following figures.

Typical Fan-powered Units

Figure 3. Parallel fan-powered terminal unit (top) and series fan-powered terminal units (bottom)

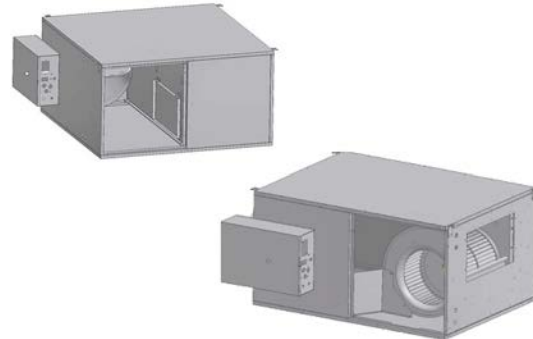
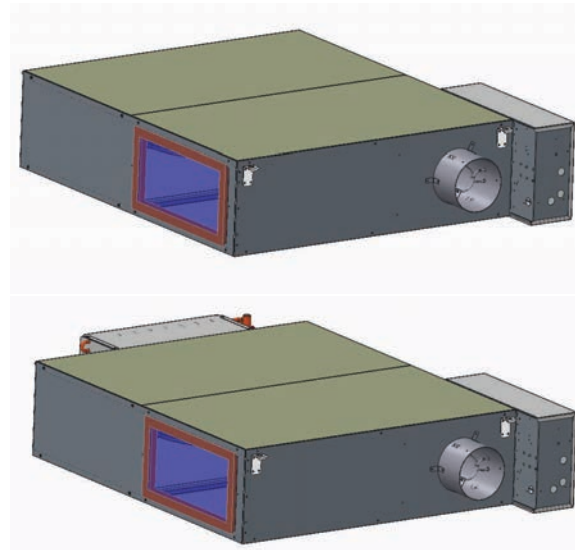

Figure 4. Low height series: LSCF (top) and low height series: LSWF (bottom)



Unit Information

Figure 5. Low height series: LSEF (top) and low height parallel: LPCF (bottom)

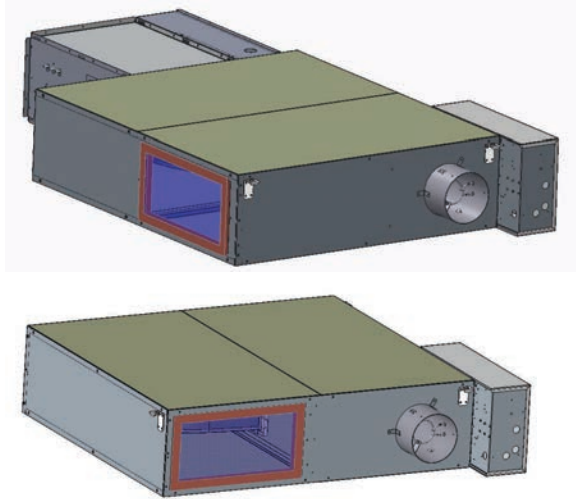
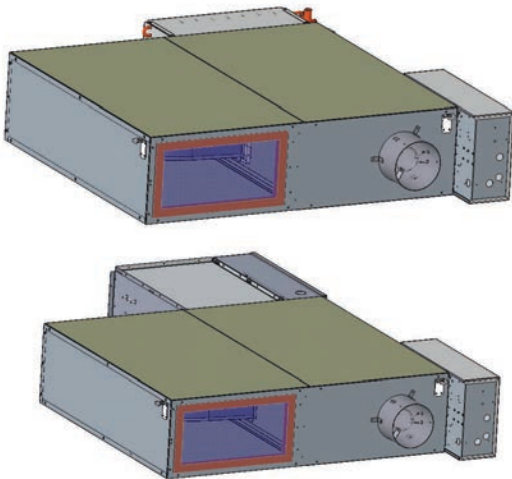

Figure 6. Low height parallel: LPWF (top) and low height parallel: LPEF (bottom)



The fan on a series unit runs continuously whenever the main air handler unit is in operation. There are three methods to start the fan: remotely, by a duct pressure switch, or by a combination of both. The particular fan control method may vary from unit to unit, depending upon job needs.

Typically, the heater is off while air valve modulates primary air and responds to zone temperature. If zone temperature decreases to the point where a decrease in primary air will not maintain the desired temperature, the re-heat will be activated to increase the temperature of the discharge air.

On a parallel unit, the VariTrane™ air valve delivers primary cooling air to the unit outlet. When the space temperature decreases beyond air valve control, the

fan is turned on as the first stage of heat. The fan delivers plenum air from above the occupied space to the unit outlet, which is mixed with primary air and delivered to the occupied space.

Note: *Either the fan, the air valve, or both can deliver airflow into the occupied space. In order to prevent primary airflow from exiting through the fan when the fan is not running on a parallel unit, a back draft damper is provided. When the fan is not running, the efficiency of this system is the same as a standard single-duct VAV unit.*

Typically, the control systems applied to parallel units cause the air valve to close to zero or a minimum flow before the fan is activated. After the fan is activated, the optional heat will be activated upon further reduction in zone temperature. Minimal primary air is mixed with the heated air.

VariTrane™ fan-powered unit fan sizes 02SQ–05SQ, DS02, PS02 and DS03 were performance tested at .12 in. w.g. and sizes 06SQ and 07SQ were tested at .15 in. w.g. Units are not designed to operate without ducts and below these tested static pressures.

Note: *Fan-powered units are available with rectangular discharge connection only. The optional heater is mounted on the discharge of the unit. Hot water coils are connected to either the plenum inlet or on the discharge on parallel units, and to the discharge of series units.*

Chilled Water Sensible Cooling Terminal Units

Chilled water sensible cooling terminal units are available with or without re-heat. Refer to the following figures.

Figure 7. Chilled water sensible cooling unit

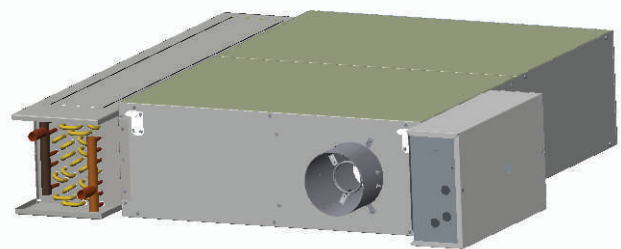

Figure 8. Chilled water sensible cooling unit with hot water coil

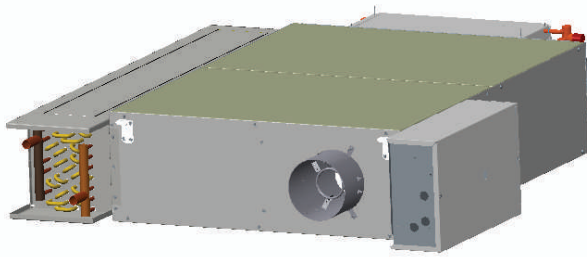
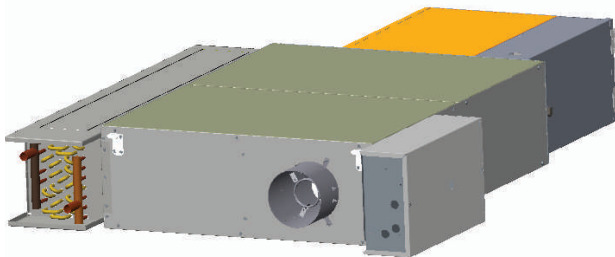

Figure 9. Chilled water sensible cooling unit with electric heat



The function of the Trane chilled water sensible cooling terminal units is a little different than traditional VAV

Terminal Units. These terminal units are part of a **system** that uses a dedicated outdoor-air unit to distribute outdoor air to an air valve on each terminal unit to meet the ventilation requirements of the zone. Each terminal unit is also equipped with a cooling coil mounted on the plenum inlet. Recirculated air from the plenum (or directly from the occupied space) is drawn in through this cooling coil by the local fan. This cooled air is then mixed with the conditioned (cooled, dehumidified, heated, or humidified) outdoor air from the dedicated OA unit, and distributed through the downstream ductwork to the zone.

In most applications, the water supplied to this local cooling coil is controlled to a temperature above the dew point in the zone. This avoids moisture in the air from condensing on the coil, so it operates dry and provides only sensible cooling. All the dehumidification must then be provided by the dedicated outdoor-air unit. Trane chilled water sensible cooling terminal units are built with a drip pan located beneath the cooling coil, with a moisture sensor installed in it, to detect and prevent any moisture from getting on the ceiling beneath the units or into the occupied space below. These terminal units can be configured with either a hot water coil or electric heater mounted at the unit discharge.

Unit Installation

⚠ WARNING

Hazardous Voltage w/Capacitors!

Failure to disconnect power and discharge capacitors before servicing could result in death or serious injury.

Disconnect all electric power, including remote disconnects and discharge all motor start/run capacitors before servicing. Follow proper lockout/tagout procedures to ensure the power cannot be inadvertently energized. For variable frequency drives or other energy storing components provided by Trane or others, refer to the appropriate manufacturer's literature for allowable waiting periods for discharge of capacitors. Verify with a CAT III or IV voltmeter rated per NFPA 70E that all capacitors have discharged.

⚠ WARNING

Proper Structural Support Required!

Failure to ensure proper structural ceiling support could result in unit falling from its location which could result in death or serious injury.

Ceiling structure must be strong enough to support the weight of the unit and any accessories. If unsure, check with a structural engineer.

Due to their weight, the VAV terminal units should be suspended from the uppermost ceiling, independent of the false ceiling grid. In fact, VAV terminal units are primarily designed for installation in the plenum space between the upper most ceiling and the false ceiling grid below it. See "Weights," p. 29 for unit weights. Suspension devices are to be supplied by the installer. Units must be installed level and upright. Failure to level the unit properly may prevent proper operation of the controls and/or terminal unit. Units are not designed to be installed vertically. Consequently, this will also void the U.L. ratings and any warranty on the unit.

Single-Duct VAV Units

Figure 10. Single-duct hanging recommendations

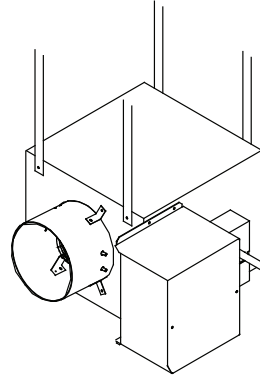

Depending upon the size and weight of the single-duct unit, it may be capable of being supported by the ductwork that is connected to it. No hanger brackets are provided on these units since the unit should be supported by means of a hanger strap. The hanger strap should be secured directly to the unit casing as shown above.

- For cooling only single-duct units or single-duct units with hot water coil, the unit may be rotated 180° for opposite side connections.
- For units with electric heat, the unit can be flipped to either RH or LH connection orientation if model number digit 22 Electrical Connections = F.

Dual-Duct VAV Units

Dual-duct units should be supported by either hanger straps or by using a threaded rod in conjunction with the hanger brackets that are provided on the unit.

Figure 11. Dual-duct hanger bracket locations

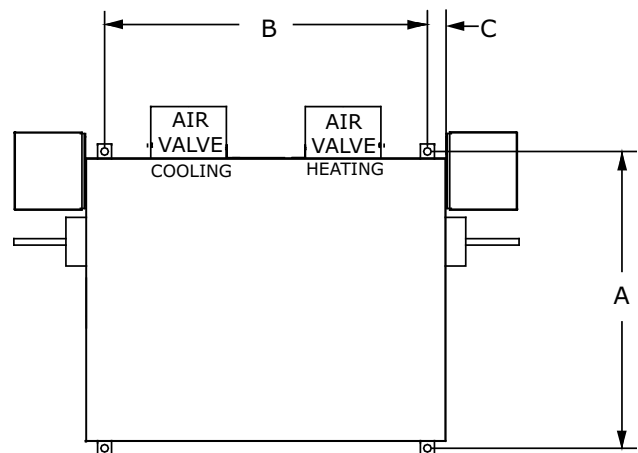

TOP VIEW

Table 1. Dual duct VAV unit hanger location dimensions

Inlet Size (in)	A		B		C	
	in	mm	in	mm	in	mm
5 thru 10	23.15	588	25.25	641	1.38	35
12 thru 16	23.15	588	37.25	946	1.38	35

Fan-Powered VAV Units and Chilled Water Sensible Cooling Terminal Units

Fan-powered (standard and low-height) and chilled water sensible cooling terminal units should be supported by either hanger straps or by using a threaded rod in conjunction with the hanger brackets that are provided on the unit. Care should be exercised to insure that the hanging straps do not block the side access panel. Refer to the following figures.

Bracket Locations – Fan Powered

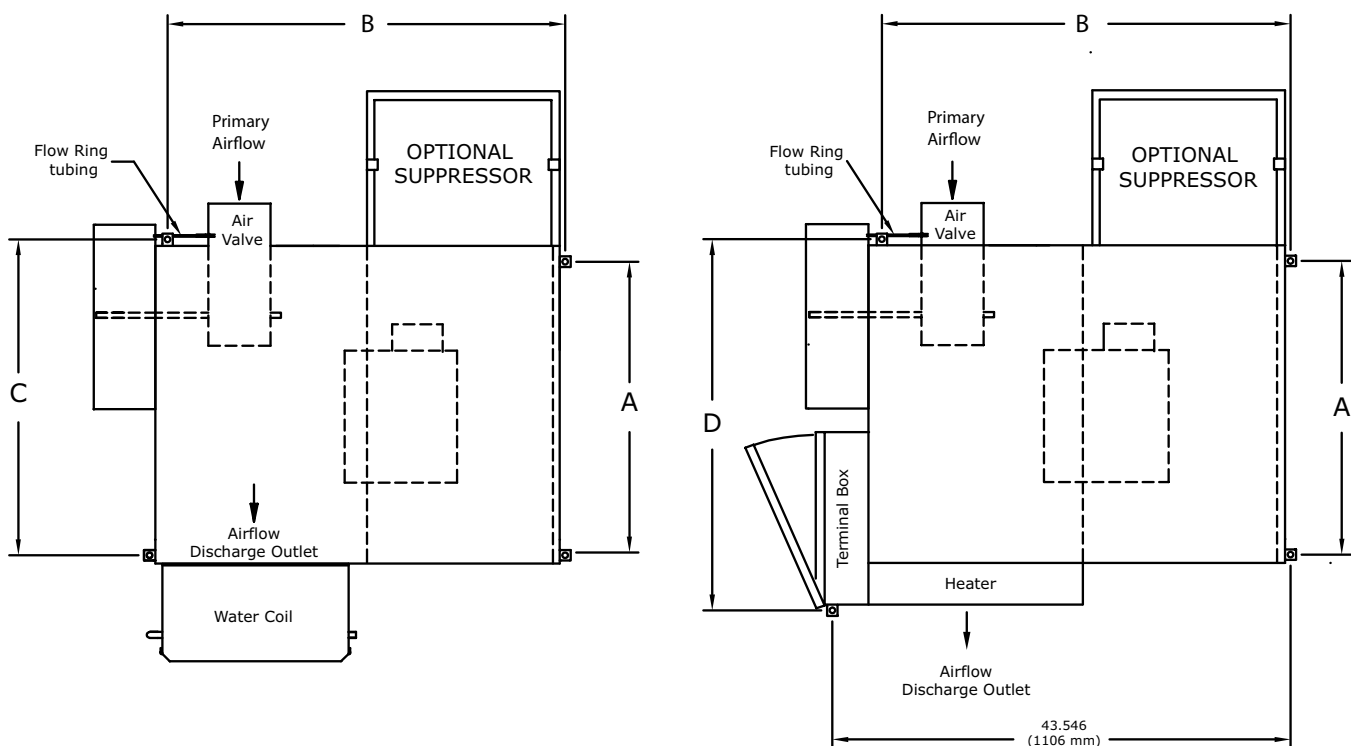
Figure 12. Parallel hanger bracket location sizes

Table 2. Parallel hanger bracket location dimensions

Fan Size	A		B		C		D	
	in.	mm	in.	mm	in.	mm	in.	mm
02SQ	26.75	679	38.95	989	28.95	735	37.10	942
03SQ, 04SQ, 05SQ	29.75	756	38.95	989	31.45	799	39.70	1008
06SQ, 07SQ	36.75	933	38.95	989	38.95	989	47.10	1196

Figure 13. Series hanger bracket locations

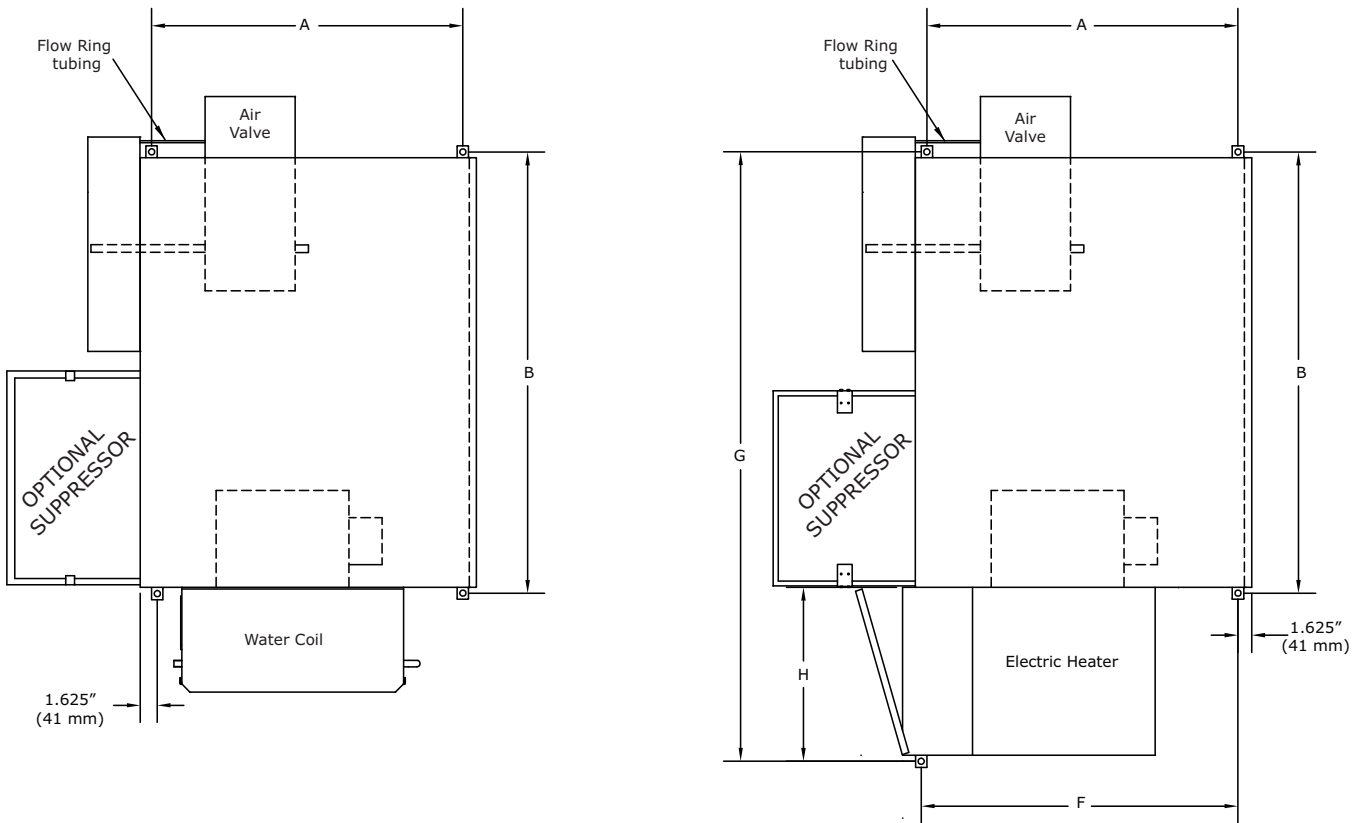

Table 3. Series hanger bracket location dimensions

Fan Size	A		B	
	in.	mm	in.	mm
02SQ	18.75	476	41.2	1041
03SQ, 04SQ	20.75	527	41.2	1041
05SQ	26.75	679	41.2	1041
06SQ, 07SQ	27.25	692	41.2	1041

Table 4. Series hanger bracket location dimensions — electric heat only

Fan Size	F		G		H	
	in.	mm	in.	mm	in.	mm
02SQ	20.13	511	53.75	1365	19.0	483
03SQ, 04SQ	23.88	606	59.75	1517	19.0	483
05SQ	28.97	736	59.75	1517	19.0	483
06SQ, 07SQ	29.88	759	58.25	1479	17.5	445

Figure 14. Low-height parallel DS02/PS02

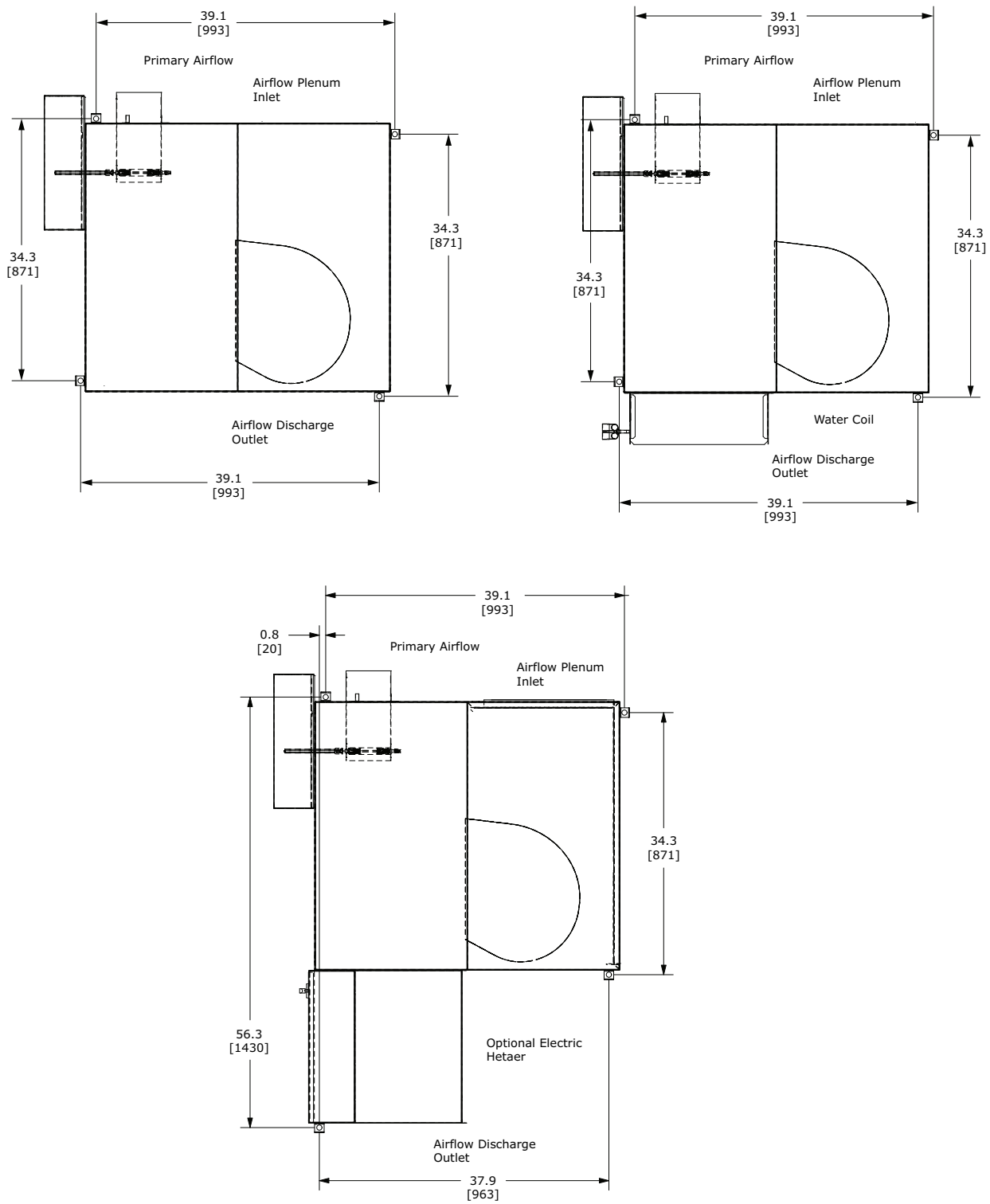
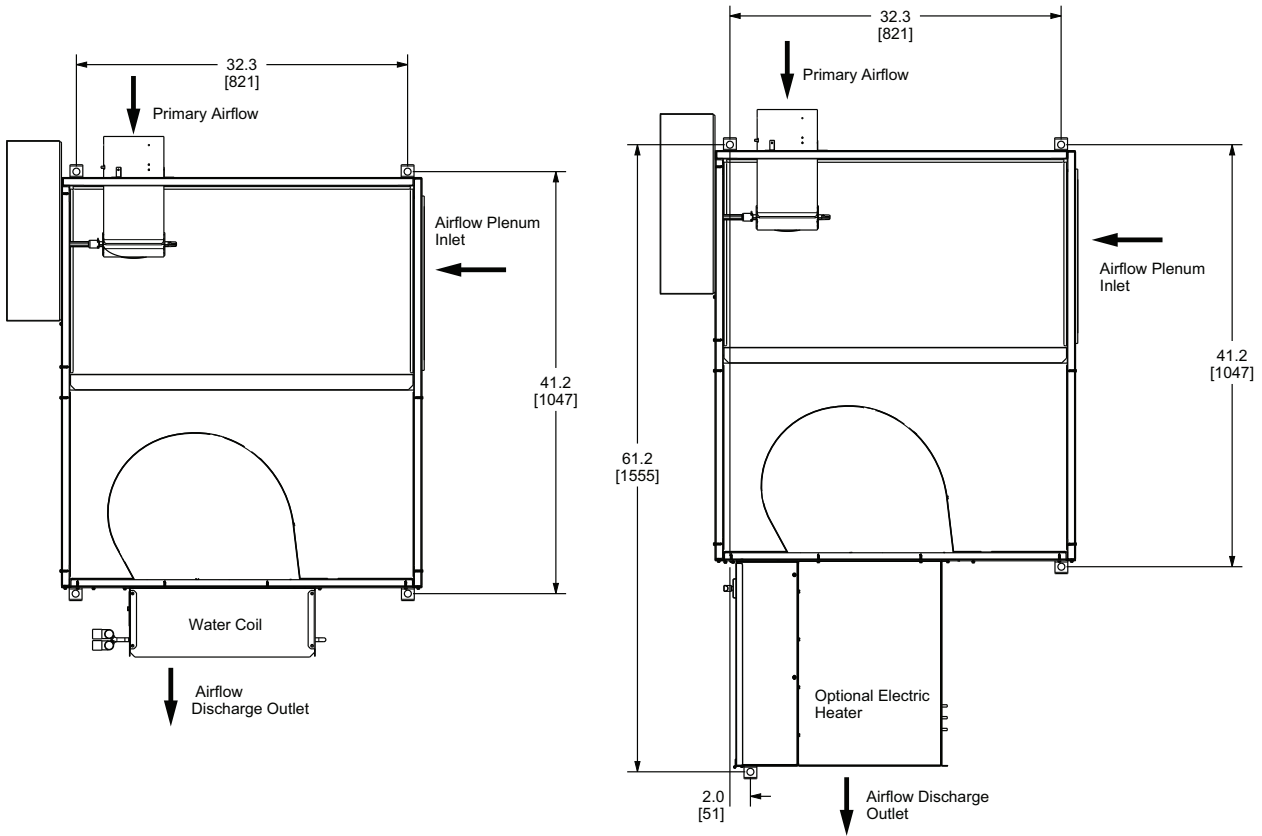

Figure 15. Low-height series DS02/PS02/DS03 w/hot water or electric heat



Bracket Locations Chilled Water Sensible Cooling Terminal Units

Figure 16. Bracket locations — cooling only unit, and unit with hot water coil

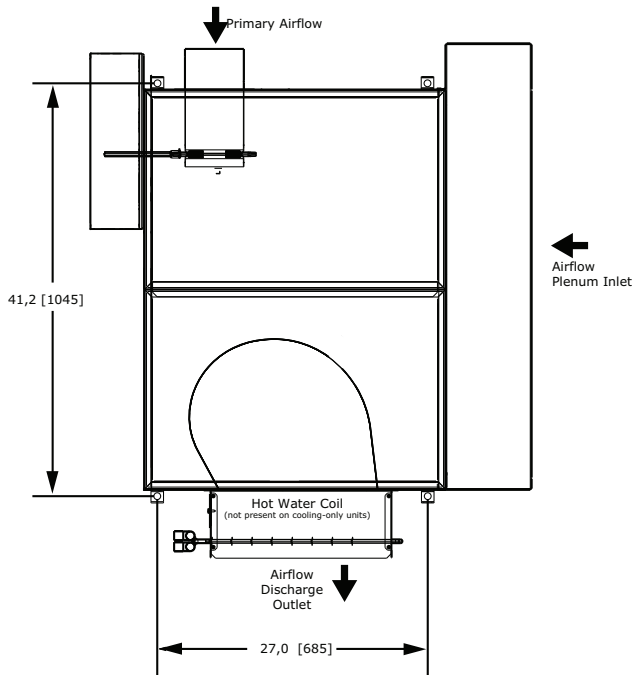
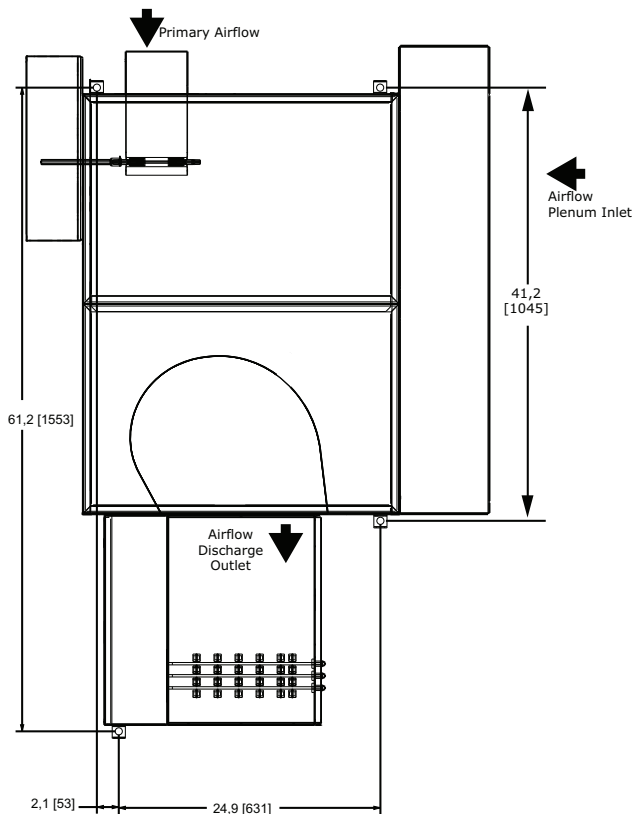

Figure 17. Bracket locations — electric heat unit



Duct Connections

All VariTrane™ units should be provided with a minimum of 1.5-duct diameters of straight duct prior to the inlet of the unit. It is recommended that at least 48 inches of straight duct be provided from the discharge of the units prior to any take-offs or transitions.

Important: This is a requirement for electric heat fan-powered units used in applications with 100% downward discharge.

In order to maintain good air distribution over the elements and not create turbulence which could cause a limit cutout there should be four feet of ductwork, consistent of the discharge dimensions of the heater, downstream of the reheat coil prior to any diffuser takeoffs for VariTrane™ electric coils.

1. After all connections are made, check that the entire ductwork system is airtight. In some high-pressure systems, duct sealer may be necessary.

Note: All inlet duct on the VAV boxes are sized approximately 0.125 inches smaller in diameter than the nominal size in order to allow the incoming duct to slide over the inlet of the VAV box.

2. Provide insulation around the entire inlet collar (all the way to the unit casing).

Note: Use caution not to damage the flow tubes when making ductwork connections or insulating.

3. Cut slits in the insulation for the flow tubes and secure with duct tape.
4. If the unit is to be installed in a location with high humidity, external insulation around the heating coil should be installed as required.

Water Coil Connections

Notes: The following coils have 0.375 inches OD water coil piping connections.

- Single Duct 1-row coils (inlet sizes 05, 05, 06, 08 or 10 only)
- Low Height Parallel Inlet 1-row
- Low Height Parallel Discharge 1-row

All others require a 0.875 inches OD water coil piping connections.

1. If necessary, you can change the coil connection from left-handed to right-handed (and vice-versa) by disconnecting the coil from the unit and rotating the coil like a steering wheel 180°.

Note: The exception is that the coil connection cannot be changed on parallel fan powered unit with hot water coil on plenum inlet.

2. Use port at the bottom for inlet and top for outlet on

Unit Installation

single row coils. For multi-row coils, always plumb in counter flow orientation.

- Water inlet is always on the airflow downstream side of the hot water coil.
 - Water outlet is always on the upstream side of the hot water coil.
3. Care should be taken to properly support the water coil piping connections while connecting the adjoining pipe.
 4. It is recommended that piping to the water coil should be done after field-mounted controls, external insulation, and ductwork connections have been completed.

Important: Do not connect water valve or pipe extensions to the water coil connections unless supported.

Discharge Duct Temperature Sensor Installation

Note: This process is to be used for control sequences that involve Discharge Air Temperature (DAT) control.

Several Tracer® UC210/UC400 control sequences perform direct DAT control of the VAV unit when both modulating unit heat and modulating ECM fan are present or when modulating unit heat is present on a non-fan-powered VAV unit. Supported modulating unit heat options include modulating hot-water and SCR-controlled electric heat. In these Tracer® UC210/UC400 control sequences, the DAT is a control input to the unit controller.

Note: Optional factory mounted discharge duct temperature sensors available with modulating unit heat control.

Important: To ensure good control of the DAT and overall level of heat being supplied to the zone, it's critical to locate the DAT sensor in a location in the downstream ductwork that is not too close to the heating water or electric coils.

1. Locate mounting location for DAT sensor a minimum of 1.5 equivalent duct diameters downstream of the heating coils and midway between top and bottom on the side of the ductwork.
2. Mount the DAT sensor using the instructions provided at the end of this manual.
3. If not already factory wired to unit controller, wire DAT sensor to unit controller using unit schematic.

Electronic Duct Temperature Sensor Installation

Visually inspect the sensor unit and harness for

damage. Return damage or defective products.

Tools required for installation:

- Cutter to release zip tie
- DVM (Digital Volt ohm Meter)
- Appropriate screw driver for mounting screws
- Appropriate drill and drill bit for mounting screws

Notes:

- Installer must be a qualified, experienced technician.
- Cut loose harness, verify location.
- Avoid location where excessive vibration, moisture, corrosive fumes or vapors are present.

1. Determine the sensor mounting location on the duct. The sensing element is located within 1 inch (25mm) of the end of the sensing probe, and it should be located in the air stream typical of the temperature requiring sensing.
2. Use the mounting plate supplied as a template (or refer to Figure 18, p. 26 for duct mounting dimensions) for mounting hole location.

Figure 18. Mounting dimensions

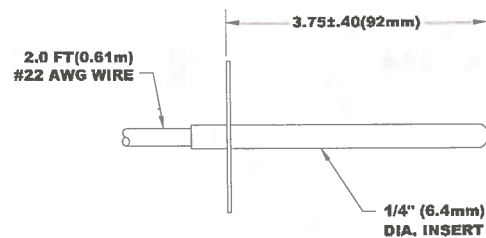

SIDE VIEW

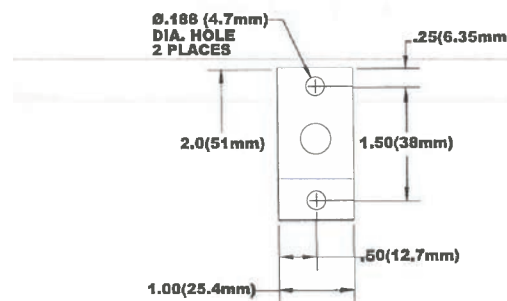

FRONT VIEW

3. Mount the sensor to the duct using (2) #8-1/6 x 1/2- in sheet metal screws.

Chilled Water Sensible Cooling Terminal Units Moisture Sensor Installation

In most applications, the water supplied to this local cooling coil is controlled to a temperature above the dew point in the zone. This avoids moisture in the air from condensing on the coil, so it operates dry and provides only sensible cooling. All dehumidification must then be provided by the dedicated outdoor-air unit. Trane chilled water sensible cooling terminal units are built with a drip pan located beneath and above the cooling coil, with a moisture sensor installed, to detect and prevent any moisture from getting on the ceiling beneath the units or into the occupied space below. Sensible cooling units are designed so that the unit can be flipped 180 degrees for right and left hand orientation. They are configured as left hand from the factory with a moisture sensor installed to a bracket on the bottom of the drip pan. If installed as a right hand unit the moisture sensor and bracket will need to be moved to the adhesive tape provided (shown in the following figure) so that the moisture sensor is on the bottom of the unit for proper moisture detection.

Figure 19. Moisture sensor installation and additional adhesive tape shown in cooling coil drip pan



Unit Accessibility

- Single-duct and dual-duct units provided with hot water reheat have an access panel located on the side of the water coil. All other single-duct and dual-duct units are provided without access, as all functioning components are external to the unit.
- Fan-powered terminals are provided with a sliding side access.
- Low-height terminal units have a removable bottom panel.

Clearances

For proper service, it is recommended that at least 3 inches" of side clearance be provided to service and access single-duct and dual-duct terminals units.

- Fan-powered VAV units have a plenum inlet that must be clear of obstructions. Allow at least 36 inches of clearance in front of the side access and plenum opening.
- Low-height fan-powered terminals require the same plenum clearance requirement that applies to the standard fan-powered units. However the access to the internal components is located on the bottom of the unit.
- Fan-powered VAV units with Suppressor attenuator requires at least 4.5 inches (6 inches preferred) clearance above the plenum opening.
- Fan-powered VAV units with Thinline Suppressor attenuator requires at least 4.5 inches (6 inches preferred) clearance at plenum openings.

It is also recommended that 6 inches of clearance be provided to the top and bottom of all the units.

Note: *The minimum clearance for controls and heater controls should be 36 inches for all models except units with 575-volt electric heaters, which require 48 inches of clearance. NEC™ and/or local codes override all clearance requirements.*

Mounting Actuator

Important: *When installing or replacing the actuator tighten the actuator set screw per the manufacturer's instructions. Failure to follow the manufacturer's specifications may result in unit malfunction.*

Trane offers a factory-mounted actuator with a 90-second drive time. The actuator drives 1° per second. A field-installed actuator may be used if desired. The actuator shaft has a 0.5 inch diameter and is designed to travel clockwise to close the damper and counter-clockwise to open the damper. There is an indicator on the end of the actuator shaft that can be used to determine the position of the damper.



Stand-alone Units

Stand-alone UCM 4.2

When there is no communication to the UCM control and the unit is in the stand-alone mode the control action is determined by the auxiliary temperature sensor located on TB3-5 and TB3-6 terminals on the UCM board. In order for the auxiliary sensor to determine the control action (heat, cool) it must be located in the supply duct, upstream of the VAV unit. The auxiliary temperature is then compared to the zone temperature. If the supply air temperature is 10 degrees above the zone temperature, then the control action will be heat. If the supply air temperature is less than or equal to the zone temperature, then the control action will be cool. If the supply air temperature is between the zone temperature and the zone temperature + 10°F (5.5°C) [zone temperature < supply air temperature < zone temperature + 10°F] (5.5°C), the control action remains the same and the UCM controls to the minimum flow set point. If an auxiliary sensor is not installed the UCM will retain the last control action in effect.

Stand-alone VV550 LonTalk Control

When there is no communication to the VV550 control and the unit is in the stand-alone mode the control action is determined by the auxiliary temperature sensor located on TB3-5 and TB3-6 terminals on the VV550 board. The control must also be configured through the Inputs Tab of Analog Input 4 as Primary Supply Air Sensor. In order for the auxiliary sensor to determine the control action (heat, cool) it must be located in the supply duct, upstream of the VAV unit. The auxiliary temperature is then compared to the zone temperature. If the supply air temperature is 10 degrees above the zone temperature, then the control action will be heat. If the supply air temperature is less than or equal to the zone temperature, then the control action will be cool. If the supply air temperature is between the zone temperature and the zone temperature + 10°F (5.5°C) [zone temperature < supply air temperature < zone temperature + 10°F] (5.5°C), the control action remains the same and the UCM controls to the minimum flow set point. If an auxiliary sensor is not installed the UCM will retain the last control action in effect.

Stand-alone UC400

When there is no communication to the UC400 control and the unit is in the stand-alone mode the control action is determined by the auxiliary temperature sensor located on AI5 terminals on the UC400 control. This input may have to be changed from AI4 (Discharge Air Input) as wired from the factory. In order for the auxiliary temperature sensor to determine the control action (heat, cool) it must be located in the supply duct, upstream of the VAV unit. The auxiliary temperature is then compared to the zone temperature. If the supply

air temperature is 10°F above the zone temperature, then the control action will be heat. If the supply air temperature is less than or equal to the zone temperature, then the control action will be cool. If the supply air temperature is between the zone temperature and the zone temperature + 10°F (5.5°C) [zone temperature < supply air temperature < zone temperature + 10°F] (5.5°C), the control action remains the same and the UC400 controls to the minimum flow set point. If an auxiliary sensor is not installed the UC400 will retain the last control action in effect.

Stand-alone UC210, Symbio 210, and Symbio 210e

When there is no communication to the Symbio 210, Symbio 210e, or UC210 control and the unit is in the stand-alone mode the control action is determined by the auxiliary temperature sensor located on AI3 terminals on the Symbio 210, Symbio 210e, or UC210 control. From the factory, this input is configured for discharge air temperature and needs to be field reconfigured as supply air temperature using Tracer® TU. In order for the auxiliary temperature sensor that is configured for supply air temperature to determine the control action (heat, cool) it must be located in the supply duct, upstream of the VAV unit. The supply air temperature is then compared to the zone temperature. If the supply air temperature is 10°F above the zone temperature, then the control action will be heat. If the supply air temperature is less than or equal to the zone temperature, then the control action will be cool. If the supply air temperature is between the zone temperature and the zone temperature + 10°F (5.5°C) [zone temperature < supply air temperature < zone temperature + 10°F] (5.5°C), the control action remains the same and the Symbio 210, Symbio 210e, or UC210 controls to the minimum flow set point. If an auxiliary temperature sensor is not installed and configured for supply air temperature, the Symbio 210, Symbio 210e, or UC210 will retain the last control action in effect.

Bottom Access

An optional bottom access can be provided in the casing of fan powered series or parallel terminal unit.

The 22-gauge door is lined with 1 inch, 26-gauge, dual wall insulation and thermal lined with 1 inch – 1 lb. density fiberglass insulation with a 3.85 R-value.

Each door includes 1 to 6 cam locks that are used to secure the door to the casing.

The cam lock engages a metal encapsulated frame on the unit that encloses the unit insulation to prevent air erosion.

The cam lock engagements are interlocked using a flat head screwdriver. Once unlocked, the entire door assembly can be removed for access.

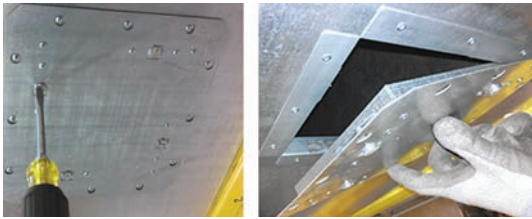
Figure 20. Bottom access

Weights

Table 5. Single-duct units – lb/kg

Unit Size	Single Wall						Dual Wall					
	VCCF	VCEF	VCWF				VCCF	VCEF	VCWF			
			1-Row	2-Row	3-Row	4-Row			1-Row	2-Row	3-Row	4-Row
4	16/7	38/17	21/10	22/10	23/11	24/11	19/9	48/22	24/11	25/11	26/12	27/12
5	16/7	38/17	21/10	22/10	23/11	24/11	19/9	48/22	24/11	25/11	26/12	27/12
6	16/7	38/17	21/10	22/10	22/10	24/11	19/9	48/22	24/11	25/11	25/11	27/12
8	16/7	38/17	21/10	24/11	24/11	26/12	20/9	49/22	25/11	28/13	28/13	30/14
10	22/10	46/21	29/13	32/15	32/15	36/16	27/12	60/27	34/15	37/17	37/17	41/19
12	27/12	52/24	37/17	40/18	41/19	45/20	34/15	68/31	43/20	47/21	48/22	52/24
14	32/15	60/27	44/20	48/22	51/23	55/25	41/19	80/36	53/24	57/26	60/27	64/29
16	35/16	69/31	49/22	54/24	56/25	61/28	46/21	91/41	60/27	65/29	67/30	72/33
24	52/24	84/38	70/32	77/35	76/35	82/37	63/29	106/48	81/37	88/40	87/40	93/42

Table 6. Dual-duct units – lb/kg

Unit Size	VDDF	VDDF w/Dual Wall
505	54/24	68/31
506	54/24	68/31
606	54/24	68/31
508	55/25	68/31
608	55/25	69/31
510	56/25	69/31
808	56/25	70/32
610	56/25	70/32
810	57/26	70/32
1010	61/28	74/34
612	57/26	70/32
812	58/26	71/32
1012	59/27	72/33
1212	60/27	84/38
814	78/35	102/46
1014	79/36	103/47
1214	80/36	104/47
1414	81/37	105/48
816	79/36	103/47



Unit Installation

Table 6. Dual-duct units – lb/kg (continued)

Unit Size	VDDF	VDDF w/Dual Wall
1016	80/36	104/47
1216	81/37	105/48
1416	82/37	105/48
1616	83/38	106/48

Table 7. Parallel fan-powered units – lb/kg

Unit Size	Single Wall				Dual Wall				VPxF Suppressor
	VPCF	VPEF	VPWF		VPCF	VPEF	VPWF		
			1-Row	2-Row			1-Row	2-Row	
0502SQ	81/37	110/550	92/42	95/43	115/52	144/65	126/57	129/59	15.5/7.0
0602SQ	80/36	109/49	91/41	94/43	114/52	143/65	125/57	128/58	15.5/7.0
0603SQ	83/38	112/51	105/48	108/49	117/53	146/66	139/63	142/64	16.5/7.5
0802SQ	81/37	110/50	92/42	95/43	115/52	144/65	126/57	129/59	15.5/7.0
0803SQ	83/38	112/51	105/48	108/49	117/53	146/66	139/63	142/64	16.5/7.5
0804SQ	84/38	113/51	106/48	109/49	118/54	147/67	140/64	143/65	16.5/7.5
1002SQ	82/37	111/50	93/42	96/44	116/53	145/66	127/58	130/59	15.5/7.0
1003SQ	84/38	113/51	106/48	109/49	118/54	147/67	140/64	143/65	16.5/7.5
1004SQ	85/39	114/52	107/49	110/50	119/54	148/67	141/64	144/65	16.5/7.5
1005SQ	98/44	128/58	120/54	123/56	132/60	162/73	154/70	157/71	16.5/7.5
1006SQ	114/52	144/65	127/58	130/59	148/67	178/81	161/73	164/74	20.5/9.3
1007SQ	122/55	152/69	135/61	138/63	156/71	186/84	169/77	172/78	20.5/9.3
1203SQ	85/39	114/52	107/49	110/50	119/54	148/67	141/64	144/65	16.5/7.5
1204SQ	86/39	115/52	108/49	111/50	120/54	149/68	142/64	145/66	16.5/7.5
1205SQ	99/45	129/59	121/55	124/56	133/60	163/74	155/70	158/72	15.5/7.0
1206SQ	115/52	145/66	128/58	131/59	149/68	179/81	162/73	165/75	20.5/9.3
1207SQ	123/56	153/69	136/62	139/63	157/71	187/85	170/77	173/78	20.5/9.3
1404SQ	87/39	116/53	109/49	112/51	121/55	150/68	143/65	146/66	16.5/7.5
1405SQ	100/45	130/59	122/55	125/57	134/61	164/74	156/71	159/72	16.5/7.5
1406SQ	116/53	146/66	129/59	132/60	150/68	180/82	163/74	166/75	20.5/9.3
1407SQ	124/56	154/70	137/62	140/64	158/72	188/85	171/78	174/79	20.5/9.3
1606SQ	117/53	147/67	130/59	133/60	151/68	181/82	164/74	167/76	20.5/9.3
1607SQ	125/57	155/70	138/63	141/64	159/72	189/86	172/78	175/79	20.5/9.3

Table 8. Series fan-powered units – lb/kg

Unit Size	Single Wall				Dual Wall				VSxF Suppressor
	VSCF	VSEF	VSWF		VSCF	VSEF	VSWF		
			1-Row	2-Row			1-Row	2-Row	
0402SQ	78/35	104/47	85/39	87/39	93/42	119/54	100/45	102/46	11.0/5.0
0502SQ	78/35	104/47	85/39	87/39	93/42	119/54	100/45	102/46	11.0/5.0
0602SQ	77/35	103/47	84/38	86/39	92/42	118/54	99/45	101/46	11.0/5.0

Table 8. Series fan-powered units — lb/kg (continued)

Unit Size	Single Wall				Dual Wall				VSxF Suppressor
	VSCF	VSEF	VSWF		VSCF	VSEF	VSWF		
			1-Row	2-Row			1-Row	2-Row	
0603SQ	76/34	105/48	88/40	92/42	100/45	129/59	112/51	116/53	16.5/7.5
0604SQ	87/39	116/53	99/45	103/47	111/50	140/64	123/56	127/58	16.5/7.5
0802SQ	79/36	105/48	86/39	88/40	94/43	120/54	101/46	103/47	11.0/5.0
0803SQ	77/35	106/48	89/40	93/42	101/46	130/59	113/51	117/53	16.5/7.5
0804SQ	88/40	117/53	100/45	104/47	112/51	141/64	124/56	128/58	16.5/7.5
1002SQ	81/37	107/49	88/40	90/41	96/44	122/55	103/47	105/48	11.0/5.0
1003SQ	80/36	109/49	92/42	96/44	104/47	133/60	116/53	120/54	16.5/7.5
1004SQ	91/41	120/54	103/47	107/49	115/52	144/65	127/58	131/59	16.5/7.5
1005SQ	92/42	121/55	104/47	108/49	116/53	145/66	128/58	132/60	16.5/7.5
1006SQ	104/47	135/61	119/54	124/56	133/60	164/74	148/67	153/69	22.5/10.2
1007SQ	117/53	148/67	132/60	137/62	146/66	177/80	161/73	166/75	22.5/10.2
1203SQ	82/37	111/50	94/43	98/44	106/48	135/61	118/54	122/55	16.5/7.5
1204SQ	92/42	121/55	104/47	108/49	116/53	145/66	128/58	132/60	16.5/7.5
1205SQ	94/43	123/56	106/48	110/50	118/54	147/67	130/59	134/61	16.5/7.5
1206SQ	105/48	136/62	120/54	125/57	134/61	165/75	149/68	154/70	22.5/10.2
1207SQ	118/54	149/68	133/60	138/63	147/67	178/81	162/73	167/76	22.5/10.2
1404SQ	93/42	122/55	105/48	109/49	117/53	146/66	129/59	133/60	16.5/7.5
1405SQ	96/44	125/57	108/49	112/51	120/54	149/68	132/60	136/62	16.5/7.5
1406SQ	106/48	137/62	121/55	126/57	135/61	166/75	150/68	155/70	22.5/10.2
1407SQ	119/54	150/68	134/61	139/63	148/67	179/81	163/74	168/76	22.5/10.2
1606SQ	107/49	138/63	122/55	127/58	136/62	167/76	151/68	156/71	22.5/10.2
1607SQ	120/54	151/68	135/61	140/64	149/68	180/82	164/74	169/77	22.5/10.2

Table 9. Low height parallel units — lb/kg

Unit Size	Single Wall				Dual Wall				LPxF Attenuator
	LPCF	LPEF	LPWF		LPCF	LPEF	LPWF		
			1-Row	2-Row			1-Row	2-Row	
05DS02	90/41	109/49	97/44	99/45	114/51	132/60	120/54	122/55	14/6
05PS02	93/42	110/50	99/45	101/46	116/52	133/60	122/55	124/56	14/6
06DS02	90/41	108/49	96/43	96/43	113/51	131/59	119/54	121/55	14/6
06PS02	92/42	110/50	98/44	100/45	115/52	133/60	121/55	123/56	14/6
08DS02	91/41	109/49	97/44	99/45	114/51	132/60	120/54	122/55	14/6
08PS02	93/42	110/50	99/45	101/46	116/52	133/60	122/55	124/56	14/6
14RTDS02	109/49	121/55	109/49	111/50	132/60	144/65	132/60	134/61	14/6
14RTPS02	111/50	123/56	111/50	113/51	134/61	146/66	134/61	136/61	14/6



Unit Installation

Table 10. Low-height series units – lb/kg

Unit Size	Single Wall				Dual Wall				LSxF Attenuator
	LSCF	LSEF	LSWF		LSCF	LSEF	LSWF		
			1-Row	2-Row			1-Row	2-Row	
04DS02	89/41	107/49	95/43	97/44	112/51	130/59	118/54	120/55	14/6
04PS02	91/42	108/49	97/44	99/45	114/52	131/60	120/55	122/55	14/6
05DS02	89/41	107/49	95/43	97/44	112/51	130/59	118/54	120/55	14/6
05PS02	91/42	108/49	97/44	99/45	114/52	131/60	120/55	122/55	14/6
06DS02	88/40	106/48	94/43	96/44	111/50	129/59	117/53	119/54	14/6
06PS02	90/41	108/49	96/44	98/45	113/51	131/60	119/54	121/55	14/6
06DS03	94/43	112/51	100/45	104/47	117/53	135/61	123/56	127/58	14/6
08DS02	89/41	107/49	95/43	97/44	112/51	130/59	118/54	120/55	14/6
08PS02	91/42	108/49	97/44	99/45	114/52	131/60	120/55	122/55	14/6
08DS03	95/43	113/51	101/46	105/48	118/54	136/62	124/56	128/58	14/6
10DS03	97/44	115/52	103/47	107/49	120/55	138/63	126/57	130/59	14/6
14RTDS02	107/49	119/54	107/49	109/50	130/59	142/65	130/59	132/60	14/6
14RTPS02	109/50	121/55	109/50	111/50	132/60	144/65	132/60	134/61	14/6
14RTDS03	100/45	118/54	106/48	110/50	122/55	140/64	128/58	132/60	14/6

Table 11. Chilled water sensible coil terminal units – lb/kg

Unit Size	Single Wall				Dual Wall			
	LDCF	LDEF	LDWF		LDCF	LDEF	LDWF	
			1-Row	2-Row			1-Row	2-Row
DS02	125/57	143/65	131/59	135/61	148/67	166/75	154/70	158/72



Unit Setup

Figure 21. Flow sensor ΔP vs. airflow delivery

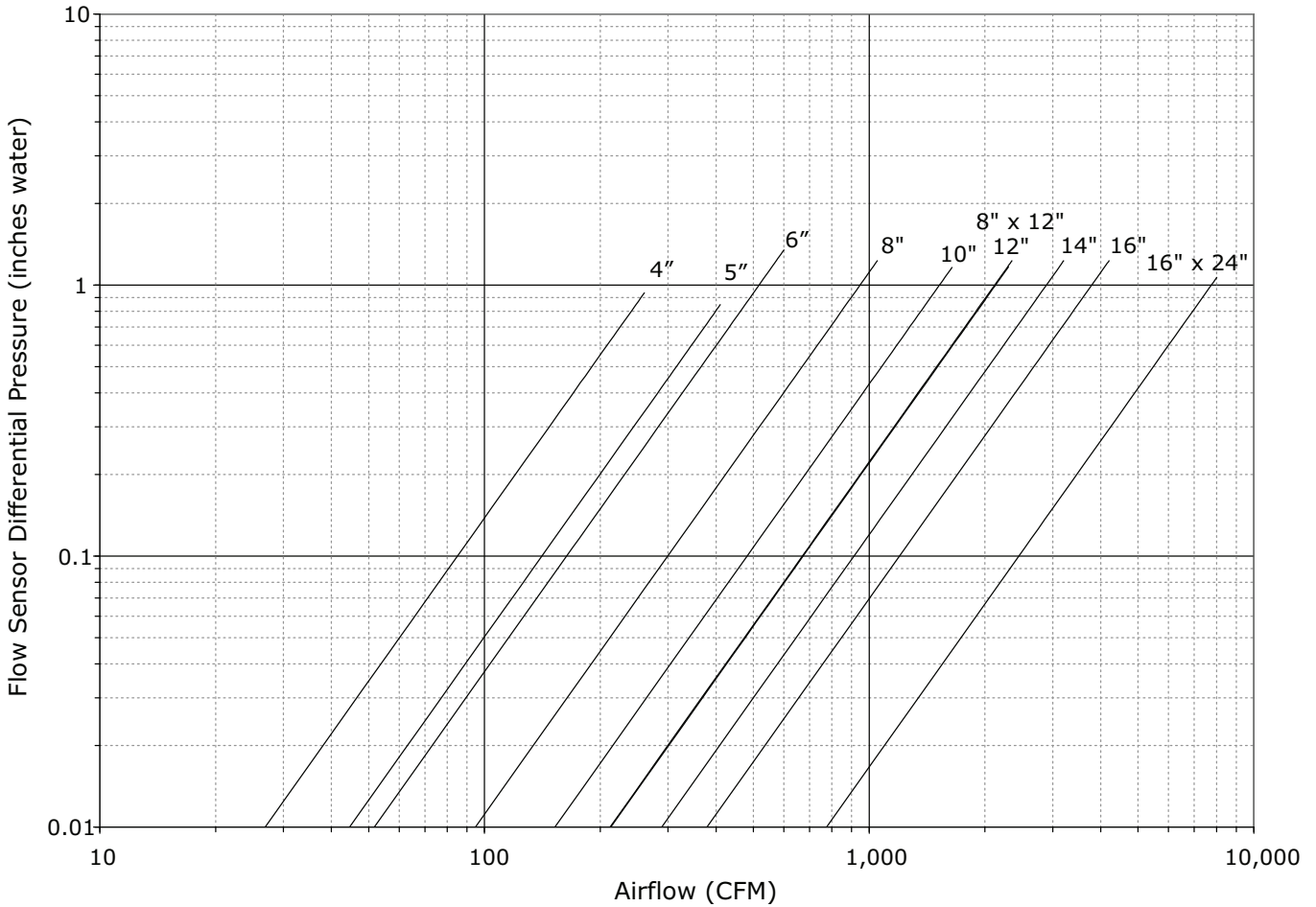

Fan Motor Amperage

Reference unit submittal data and motor nameplate.

Adjusting the SCR Motor Speed Control

In order to make units more convenient and efficient to balance, an SCR (silicone control rectifier) is provided as standard on all fan-powered units.

The SCR is located on the side of the fan control box. To adjust the speed of the motor, the external knob must be rotated either clockwise or counterclockwise depending on the desired speed adjustment.

There is an internal potentiometer setting on the SCR controller that can be accessed by removing the control box cover. This internal potentiometer is set at the factory to the specific motor voltage.

It may be necessary to adjust this in the field depending on the building power factor.

Figure 22. SCR (top) and internal potentiometer (bottom)

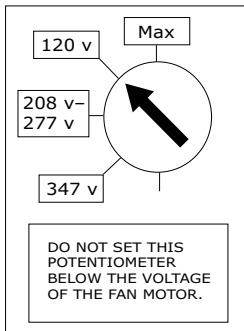

Note: Do not set this potentiometer below the voltage of the fan motor.

Electrically Commutated Motor (ECM)

Figure 23. ECM control board – Non-modulating control with Trane unit controller (excludes Tracer® UC210 and UC400) or non-Trane unit controller



Trane offers an energy efficient ECM as a motor option. The optional Tracer® UC210 and UC400 unit controllers directly interface with the ECM to control fan airflow and fan on/off control. Other Trane and non-Trane unit controller options require an ECM control interface (shown in Figure 23, p. 34) to set fan airflow while the unit controller dictates fan on/off control via a binary output. The manual potentiometer is used to set the percent-on or speed. The ECM control interface contains display, which can be used to view percent-on setting and speed.

Note: This feature only verifies airflow is set properly. It does not indicate actual ECM speed. The ECM must be load tested. The ECM must be connected to the fan to properly test the ECM and display fan speed.

The following tables provide mapping from fan percent-on setting to fan airflow for each fan type and size. Additional fan settings can be determined by interpolating from the tables or using the following equation:

- Airflow setting = Airflow min + {(Potentiometer Setting) x [(Airflow max - Airflow min)/100]}

Figure 24. ECM control board – Modulating control with non-Trane unit controller

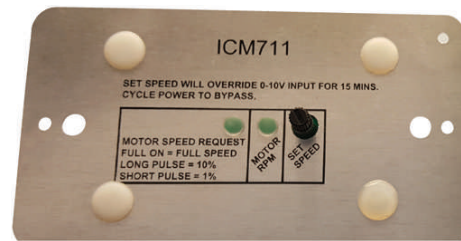

An alternate ECM interface (shown in Figure 24, p. 34) is utilized on unit with Non-Trane unit controller including factory mounted third-party unit controllers. This ECM interface allows fan modulation and fan on/off control from the unit controller. There are two input signal options as well as a temporary adjustment via manual potentiometer.

- 0-10 VDC modulation signal with separate on/off binary signal.
- 2-10 VDC modulation signal where the ECM starts at a rise to 2 VDC and stops at a fall to 1 VDC.

Note: 2-10 VDC input signal requires the shunt to be installed on the "P" terminals as shown in Figure 25, p. 34.

Figure 25. ECM control board 2-10 VDC input signal shunt placement



The ECM control interface contains two diagnostic LED indicators, motor RPM (speed) and Motor Speed Request. Motor RPM indicates the motor is driven and running when lit. Motor Speed Request, represents the percentage of the requested motor speed being

supplied to the motor. Short and long flashes are used to indicate values from 0 to 100 percent.

- 0% is displayed as an off LED.
- 1 – 99% are represented by a series of long flashes followed by short flashes, whereas each long flash adds 10% and each short flash adds 1%.
- 100% is displayed as a constantly lit LED.

The following tables provide mapping from input signal to fan airflow for each fan type and size. Additional fan settings can be determined by interpolating from the tables.

Table 12. VPxF 03SQ ECM CFM

Airflow (Min CFM: 160, Max CFM: 1085)		Trane Controller PWM Signal (a)	ECM Control Board Signal(b) (c)	
CFM	L/s	% Setting	0-10V	2-10V
160	76	0%	0.0	2.0
206	97	5%	0.5	2.4
253	119	10%	1.0	2.8
299	141	15%	1.5	3.2
345	163	20%	2.0	3.6
391	185	25%	2.5	4.0
438	206	30%	3.0	4.4
484	228	35%	3.5	4.8
530	250	40%	4.0	5.2
576	272	45%	4.5	5.6
623	294	50%	5.0	6.0
669	316	55%	5.5	6.4
715	337	60%	6.0	6.8
761	359	65%	6.5	7.2
808	381	70%	7.0	7.6
854	403	75%	7.5	8.0
900	425	80%	8.0	8.4
946	447	85%	8.5	8.8
993	468	90%	9.0	9.2
1039	490	95%	9.5	9.6
1085	512	100%	10.0	10.0

- (a) % setting from Trane unit controller via pulse width modulating signal or ECM control board with manual fan speed adjust setting.
 (b) ECM control board with 0-10 VDC fan modulation input and separate fan on/off binary input required.
 (c) ECM control board with 2-10 VDC, has combined fan on/off and modulation input where fan comes on when signal rises to 2 VDC and goes off when signal falls to 1 VDC.

Table 13. VPxF 04SQ ECM CFM

Airflow (Min CFM: 220, Max CFM: 1510)		Trane Controller PWM Signal (a)	ECM Control Board Signal(b) (c)	
CFM	L/s	% Setting	0-10V	2-10V
220	104	0%	0.0	2.0
285	134	5%	0.5	2.4
349	165	10%	1.0	2.8
414	195	15%	1.5	3.2
478	226	20%	2.0	3.6
543	256	25%	2.5	4.0
607	286	30%	3.0	4.4
672	317	35%	3.5	4.8
736	347	40%	4.0	5.2
800	378	45%	4.5	5.6
865	408	50%	5.0	6.0
929	439	55%	5.5	6.4
994	469	60%	6.0	6.8
1059	500	65%	6.5	7.2
1123	530	70%	7.0	7.6
1188	560	75%	7.5	8.0
1252	591	80%	8.0	8.4
1290	609	85%	8.5	8.8
1322	624	90%	9.0	9.2
1366	645	95%	9.5	9.6
1405	661	100%	10.0	10.0

- (a) % setting from Trane unit controller via pulse width modulating signal or ECM control board with manual fan speed adjust setting.
 (b) ECM control board with 0-10 VDC fan modulation input and separate fan on/off binary input required.
 (c) ECM control board with 2-10 VDC, has combined fan on/off and modulation input where fan comes on when signal rises to 2 VDC and goes off when signal falls to 1 VDC.

Table 14. VPxF 05SQ ECM CFM

Airflow (Min CFM: 280, Max CFM: 1850)		Trane Controller PWM Signal (a)	ECM Control Board Signal(b) (c)	
CFM	L/s	% Setting	0-10V	2-10V
280	132	0%	0.0	2.0
359	169	5%	0.5	2.4
437	206	10%	1.0	2.8
516	243	15%	1.5	3.2
594	280	20%	2.0	3.6
673	317	25%	2.5	4.0
751	354	30%	3.0	4.4
830	391	35%	3.5	4.8



Unit Setup

Table 14. VPxF 05SQ ECM CFM (continued)

Airflow (Min CFM: 280, Max CFM: 1850)		Trane Controller PWM Signal (a)	ECM Control Board Signal(b) (c)	
CFM	L/s	% Setting	0-10V	2-10V
908	428	40%	4.0	5.2
986	466	45%	4.5	5.6
1065	503	50%	5.0	6.0
1144	540	55%	5.5	6.4
1222	577	60%	6.0	6.8
1301	614	65%	6.5	7.2
1379	651	70%	7.0	7.6
1458	688	75%	7.5	8.0
1536	725	80%	8.0	8.4
1615	762	85%	8.5	8.8
1693	799	90%	9.0	9.2
1772	836	95%	9.5	9.6
1850	873	100%	10.0	10.0

- (a) % setting from Trane unit controller via pulse width modulating signal or ECM control board with manual fan speed adjust setting.
- (b) ECM control board with 0-10 VDC fan modulation input and separate fan on/off binary input required.
- (c) ECM control board with 2-10 VDC, has combined fan on/off and modulation input where fan comes on when signal rises to 2 VDC and goes off when signal falls to 1 VDC.

Table 15. VPxF 06SQ ECM CFM

Airflow (Min CFM: 530, Max CFM: 2100)		Trane Controller PWM Signal (a)	ECM Control Board Signal(b) (c)	
CFM	L/s	% Setting	0-10V	2-10V
530	250	0%	0.0	2.0
609	287	5%	0.5	2.4
687	324	10%	1.0	2.8
766	361	15%	1.5	3.2
844	398	20%	2.0	3.6
923	435	25%	2.5	4.0
1001	472	30%	3.0	4.4
1080	509	35%	3.5	4.8
1158	546	40%	4.0	5.2
1237	584	45%	4.5	5.6
1315	621	50%	5.0	6.0
1394	658	55%	5.5	6.4
1472	695	60%	6.0	6.8
1551	732	65%	6.5	7.2
1629	769	70%	7.0	7.6
1708	806	75%	7.5	8.0

Table 15. VPxF 06SQ ECM CFM (continued)

Airflow (Min CFM: 530, Max CFM: 2100)		Trane Controller PWM Signal (a)	ECM Control Board Signal(b) (c)	
CFM	L/s	% Setting	0-10V	2-10V
1786	843	80%	8.0	8.4
1865	880	85%	8.5	8.8
1943	917	90%	9.0	9.2
2022	954	95%	9.5	9.6
2100	991	100%	10.0	10.0

- (a) % setting from Trane unit controller via pulse width modulating signal or ECM control board with manual fan speed adjust setting.
- (b) ECM control board with 0-10 VDC fan modulation input and separate fan on/off binary input required.
- (c) ECM control board with 2-10 VDC, has combined fan on/off and modulation input where fan comes on when signal rises to 2 VDC and goes off when signal falls to 1 VDC.

Table 16. VSxF 03SQ ECM CFM

Airflow (Min CFM: 200, Max CFM: 1100)		Trane Controller PWM Signal (a)	ECM Control Board Signal(b) (c)	
CFM	L/s	% Setting	0-10V	2-10V
200	94	0%	0.0	2.0
245	116	5%	0.5	2.4
290	137	10%	1.0	2.8
335	158	15%	1.5	3.2
380	179	20%	2.0	3.6
425	201	25%	2.5	4.0
470	222	30%	3.0	4.4
515	243	35%	3.5	4.8
560	264	40%	4.0	5.2
605	285	45%	4.5	5.6
650	307	50%	5.0	6.0
695	328	55%	5.5	6.4
740	349	60%	6.0	6.8
785	370	65%	6.5	7.2
830	392	70%	7.0	7.6
875	413	75%	7.5	8.0
920	434	80%	8.0	8.4
965	455	85%	8.5	8.8
1010	477	90%	9.0	9.2
1055	498	95%	9.5	9.6
1100	519	100%	10.0	10.0

- (a) % setting from Trane unit controller via pulse width modulating signal or ECM control board with manual fan speed adjust setting.
- (b) ECM control board with 0-10 VDC fan modulation input and separate fan on/off binary input required.

Table 16. VSxF 03SQ ECM CFM (continued)

(c) ECM control board with 2-10 VDC, has combined fan on/off and modulation input where fan comes on when signal rises to 2 VDC and goes off when signal falls to 1 VDC.

Table 17. VSxF 04SQ ECM CFM

Airflow (Min CFM: 275, Max CFM: 1500)		Trane Controller PWM Signal (a)	ECM Control Board Signal(b) (c)	
CFM	L/s		% Setting	
			0-10V	2-10V
275	130	0%	0.0	2.0
336	159	5%	0.5	2.4
398	188	10%	1.0	2.8
459	216	15%	1.5	3.2
520	245	20%	2.0	3.6
581	274	25%	2.5	4.0
643	303	30%	3.0	4.4
704	332	35%	3.5	4.8
765	361	40%	4.0	5.2
826	390	45%	4.5	5.6
887	419	50%	5.0	6.0
949	448	55%	5.5	6.4
1010	477	60%	6.0	6.8
1071	506	65%	6.5	7.2
1133	534	70%	7.0	7.6
1194	563	75%	7.5	8.0
1255	592	80%	8.0	8.4
1316	621	85%	8.5	8.8
1378	650	90%	9.0	9.2
1439	679	95%	9.5	9.6
1500	708	100%	10.0	10.0

(a) % setting from Trane unit controller via pulse width modulating signal or ECM control board with manual fan speed adjust setting.
 (b) ECM control board with 0-10 VDC fan modulation input and separate fan on/off binary input required.
 (c) ECM control board with 2-10 VDC, has combined fan on/off and modulation input where fan comes on when signal rises to 2 VDC and goes off when signal falls to 1 VDC.

Table 18. VSxF 05SQ ECM CFM

Airflow (Min CFM: 350, Max CFM: 2050)		Trane Controller PWM Signal (a)	ECM Control Board Signal(b) (c)	
CFM	L/s		% Setting	
			0-10V	2-10V
350	165	0%	0.0	2.0
435	205	5%	0.5	2.4
520	245	10%	1.0	2.8
605	285	15%	1.5	3.2
690	326	20%	2.0	3.6

Table 18. VSxF 05SQ ECM CFM (continued)

Airflow (Min CFM: 350, Max CFM: 2050)		Trane Controller PWM Signal (a)	ECM Control Board Signal(b) (c)	
CFM	L/s		% Setting	
			0-10V	2-10V
775	366	25%	2.5	4.0
860	406	30%	3.0	4.4
945	446	35%	3.5	4.8
1030	486	40%	4.0	5.2
1115	526	45%	4.5	5.6
1200	566	50%	5.0	6.0
1285	606	55%	5.5	6.4
1370	647	60%	6.0	6.8
1455	687	65%	6.5	7.2
1540	727	70%	7.0	7.6
1625	767	75%	7.5	8.0
1710	807	80%	8.0	8.4
1795	847	85%	8.5	8.8
1880	887	90%	9.0	9.2
1965	927	95%	9.5	9.6
2050	967	100%	10.0	10.0

(a) % setting from Trane unit controller via pulse width modulating signal or ECM control board with manual fan speed adjust setting.
 (b) ECM control board with 0-10 VDC fan modulation input and separate fan on/off binary input required.
 (c) ECM control board with 2-10 VDC, has combined fan on/off and modulation input where fan comes on when signal rises to 2 VDC and goes off when signal falls to 1 VDC.

Table 19. VSxF 06SQ ECM CFM

Airflow (Min CFM: 700, Max CFM: 2500)		Trane Controller PWM Signal (a)	ECM Control Board Signal(b) (c)	
CFM	L/s		% Setting	
			0-10V	2-10V
700	330	0%	0.0	2.0
790	373	5%	0.5	2.4
880	415	10%	1.0	2.8
970	458	15%	1.5	3.2
1060	500	20%	2.0	3.6
1150	543	25%	2.5	4.0
1240	585	30%	3.0	4.4
1330	628	35%	3.5	4.8
1420	670	40%	4.0	5.2
1510	713	45%	4.5	5.6
1600	755	50%	5.0	6.0
1690	798	55%	5.5	6.4
1780	840	60%	6.0	6.8



Unit Setup

Table 19. VSxF 06SQ ECM CFM (continued)

Airflow (Min CFM: 700, Max CFM: 2500)		Trane Controller PWM Signal (a)	ECM Control Board Signal(b) (c)	
CFM	L/s	% Setting	0-10V	2-10V
1870	882	65%	6.5	7.2
1960	925	70%	7.0	7.6
2050	967	75%	7.5	8.0
2140	1010	80%	8.0	8.4
2230	1052	85%	8.5	8.8
2320	1095	90%	9.0	9.2
2410	1137	95%	9.5	9.6
2500	1180	100%	10.0	10.0

- (a) % setting from Trane unit controller via pulse width modulating signal or ECM control board with manual fan speed adjust setting.
 (b) ECM control board with 0-10 VDC fan modulation input and separate fan on/off binary input required.
 (c) ECM control board with 2-10 VDC, has combined fan on/off and modulation input where fan comes on when signal rises to 2 VDC and goes off when signal falls to 1 VDC.

Table 20. LSxF DS03 ECM CFM

Airflow (Min CFM: 100, Max CFM: 1300)		Trane Controller PWM Signal (a)	ECM Control Board Signal(b) (c)	
CFM	L/s	% Setting	0-10V	2-10V
100	47	0%	0.0	2.0
160	76	5%	0.5	2.4
220	104	10%	1.0	2.8
280	132	15%	1.5	3.2
340	160	20%	2.0	3.6
400	189	25%	2.5	4.0
460	217	30%	3.0	4.4
520	245	35%	3.5	4.8
580	274	40%	4.0	5.2
640	302	45%	4.5	5.6
700	330	50%	5.0	6.0
760	359	55%	5.5	6.4
820	387	60%	6.0	6.8
880	415	65%	6.5	7.2
940	444	70%	7.0	7.6
1000	472	75%	7.5	8.0
1060	500	80%	8.0	8.4
1120	529	85%	8.5	8.8
1180	557	90%	9.0	9.2

Table 20. LSxF DS03 ECM CFM (continued)

Airflow (Min CFM: 100, Max CFM: 1300)		Trane Controller PWM Signal (a)	ECM Control Board Signal(b) (c)	
CFM	L/s	% Setting	0-10V	2-10V
1240	585	95%	9.5	9.6
1300	613	100%	10.0	10.0

- (a) % setting from Trane unit controller via pulse width modulating signal or ECM control board with manual fan speed adjust setting.
 (b) ECM control board with 0-10 VDC fan modulation input and separate fan on/off binary input required.
 (c) ECM control board with 2-10 VDC, has combined fan on/off and modulation input where fan comes on when signal rises to 2 VDC and goes off when signal falls to 1 VDC.

Table 21. LSxF, LpxF, LDxF DS02 ECM CFM

Airflow (Min CFM: 400, Max CFM: 1800)		Trane Controller PWM Signal (a)	ECM Control Board Signal(b) (c)	
CFM	L/s	% Setting	0-10V	2-10V
400	189	0%	0.0	2.0
470	222	5%	0.5	2.4
540	255	10%	1.0	2.8
610	288	15%	1.5	3.2
680	321	20%	2.0	3.6
750	354	25%	2.5	4.0
820	387	30%	3.0	4.4
890	420	35%	3.5	4.8
960	453	40%	4.0	5.2
1030	486	45%	4.5	5.6
1100	519	50%	5.0	6.0
1170	552	55%	5.5	6.4
1240	585	60%	6.0	6.8
1310	618	65%	6.5	7.2
1380	651	70%	7.0	7.6
1450	684	75%	7.5	8.0
1520	717	80%	8.0	8.4
1590	750	85%	8.5	8.8
1660	783	90%	9.0	9.2
1730	816	95%	9.5	9.6
1800	849	100%	10.0	10.0

- (a) % setting from Trane unit controller via pulse width modulating signal or ECM control board with manual fan speed adjust setting.
 (b) ECM control board with 0-10 VDC fan modulation input and separate fan on/off binary input required.
 (c) ECM control board with 2-10 VDC, has combined fan on/off and modulation input where fan comes on when signal rises to 2 VDC and goes off when signal falls to 1 VDC.



Wiring Diagrams

Notes: See programming guides listed below for detailed class II low voltage unit controls wiring information on the following:

- UCM 4.2: VAV-SVX01*-EN
- UC400: VAV-SVX07*-EN
- UC210: BAS-SVX62*-EN
- VV550: VAV-SVP01*-EN



Wiring Diagrams

Wiring — Electric Heater Control Box

Figure 26. Single duct, single phase, 1 leg, 3 stages

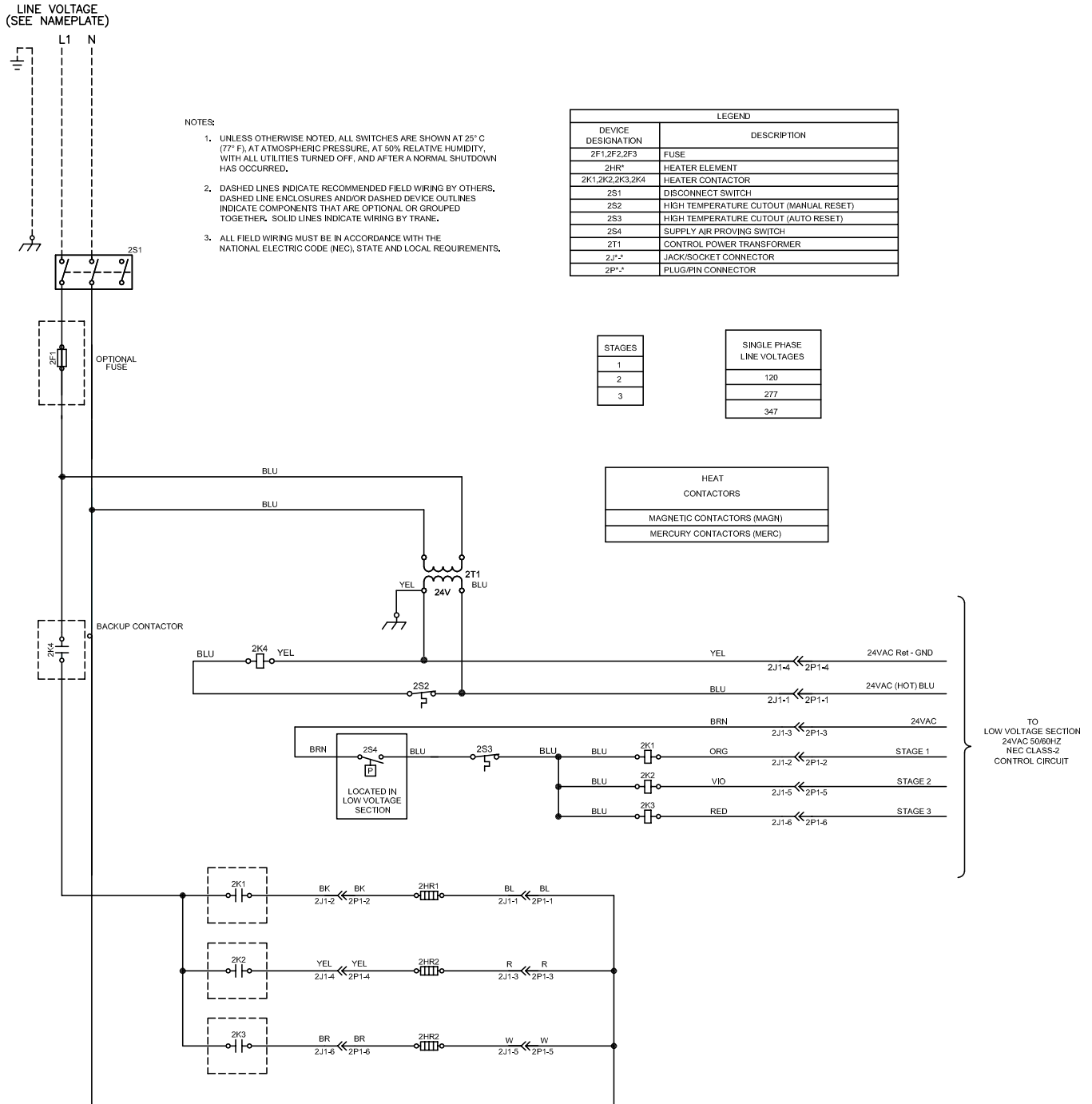
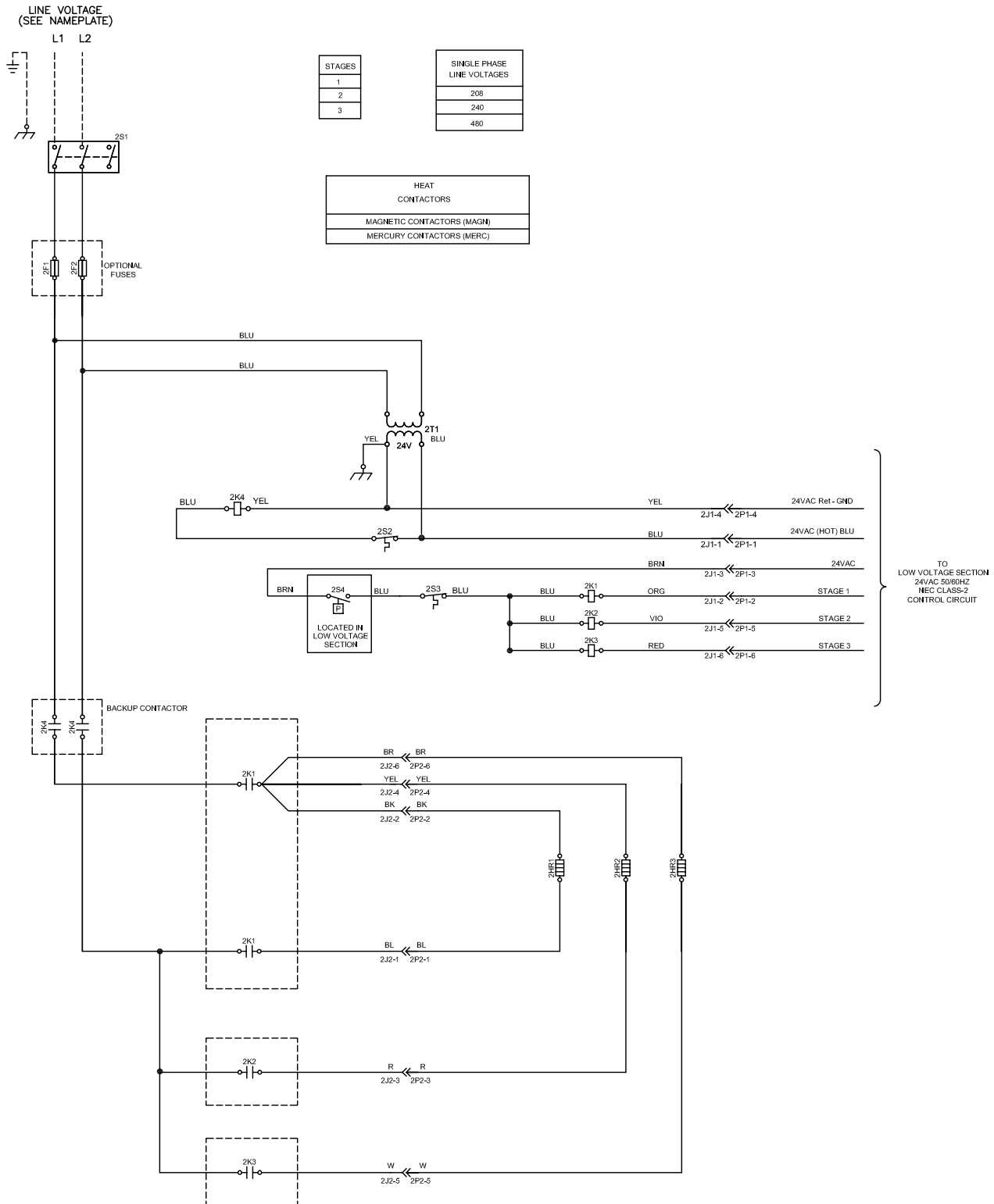

Figure 27. Single duct, single phase, 2 legs, 3 stages





Wiring Diagrams

Figure 28. Single duct, three phase, delta, 3 stages

LINE VOLTAGE
(SEE NAMEPLATE)

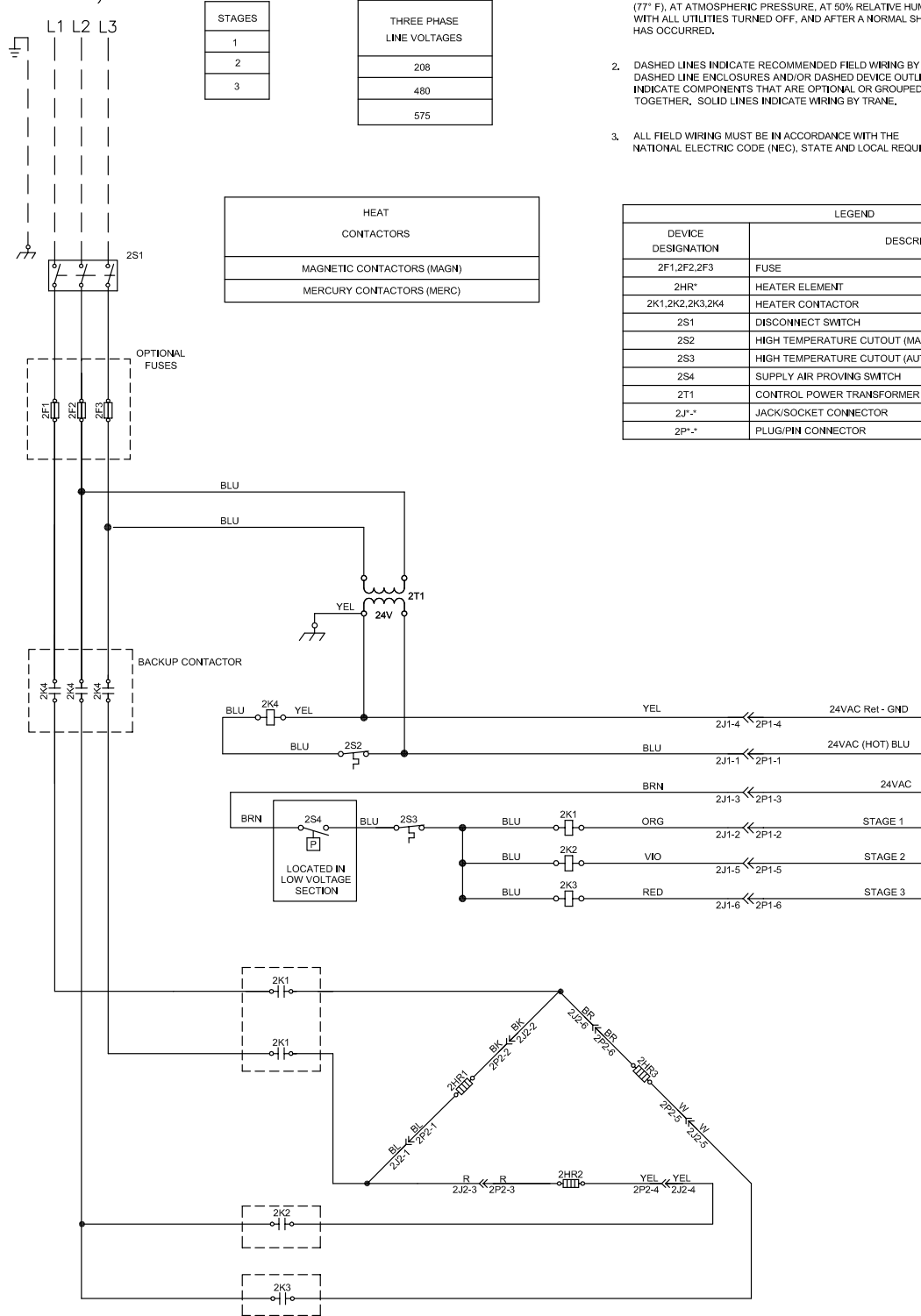

STAGES
1
2
3

THREE PHASE LINE VOLTAGES
208
480
575

HEAT CONTACTORS
MAGNETIC CONTACTORS (MAGN)
MERCURY CONTACTORS (MERC)

NOTES:

- UNLESS OTHERWISE NOTED, ALL SWITCHES ARE SHOWN AT 25° C (77° F), AT ATMOSPHERIC PRESSURE, AT 50% RELATIVE HUMIDITY, WITH ALL UTILITIES TURNED OFF, AND AFTER A NORMAL SHUTDOWN HAS OCCURRED.
- DASHED LINES INDICATE RECOMMENDED FIELD WIRING BY OTHERS. DASHED LINE ENCLOSURES AND/OR DASHED DEVICE OUTLINES INDICATE COMPONENTS THAT ARE OPTIONAL OR GROUPED TOGETHER. SOLID LINES INDICATE WIRING BY TRANE.
- ALL FIELD WIRING MUST BE IN ACCORDANCE WITH THE NATIONAL ELECTRIC CODE (NEC), STATE AND LOCAL REQUIREMENTS.

LEGEND	
DEVICE DESIGNATION	DESCRIPTION
2F1,2F2,2F3	FUSE
2HR*	HEATER ELEMENT
2K1,2K2,2K3,2K4	HEATER CONTACTOR
2S1	DISCONNECT SWITCH
2S2	HIGH TEMPERATURE CUTOUT (MANUAL RESET)
2S3	HIGH TEMPERATURE CUTOUT (AUTO RESET)
2S4	SUPPLY AIR PROVING SWITCH
2T1	CONTROL POWER TRANSFORMER
2J*~	JACK/SOCKET CONNECTOR
2P*~	PLUG/PIN CONNECTOR

TO
LOW VOLTAGE SECTION
24VAC 50/60HZ
NEC CLASS-2
CONTROL CIRCUIT

Figure 29. Single duct, single phase, SCR, 1 leg, 1 stage

LINE VOLTAGE
(SEE NAMEPLATE)

NOTES:

- UNLESS OTHERWISE NOTED, ALL SWITCHES ARE SHOWN AT 25° C (77° F), AT ATMOSPHERIC PRESSURE, AT 50% RELATIVE HUMIDITY, WITH ALL UTILITIES TURNED OFF, AND AFTER A NORMAL SHUTDOWN HAS OCCURRED.
- DASHED LINES INDICATE RECOMMENDED FIELD WIRING BY OTHERS. DASHED LINE ENCLOSURES AND/OR DASHED DEVICE OUTLINES INDICATE COMPONENTS THAT ARE OPTIONAL OR GROUPED TOGETHER. SOLID LINES INDICATE WIRING BY TRANE.
- ALL FIELD WIRING MUST BE IN ACCORDANCE WITH THE NATIONAL ELECTRIC CODE (NEC), STATE AND LOCAL REQUIREMENTS.

LEGEND	
DEVICE DESIGNATION	DESCRIPTION
2F1,2F2,2F3	FUSE
2HR*	HEATER ELEMENT
2K1,2K2,2K3,2K4	HEATER CONTACTOR
2S1	DISCONNECT SWITCH
2S2	HIGH TEMPERATURE CUTOFF (MANUAL RESET)
2S3	HIGH TEMPERATURE CUTOFF (AUTO RESET)
2S4	SUPPLY AIR PROVING SWITCH
2T1	CONTROL POWER TRANSFORMER
2J*-*	JACK/SOCKET CONNECTOR
2P*-*	PLUG/PIN CONNECTOR
SSR1, SSR2	SOLID STATE CONTACTORS
PW1	POWER SUPPLY

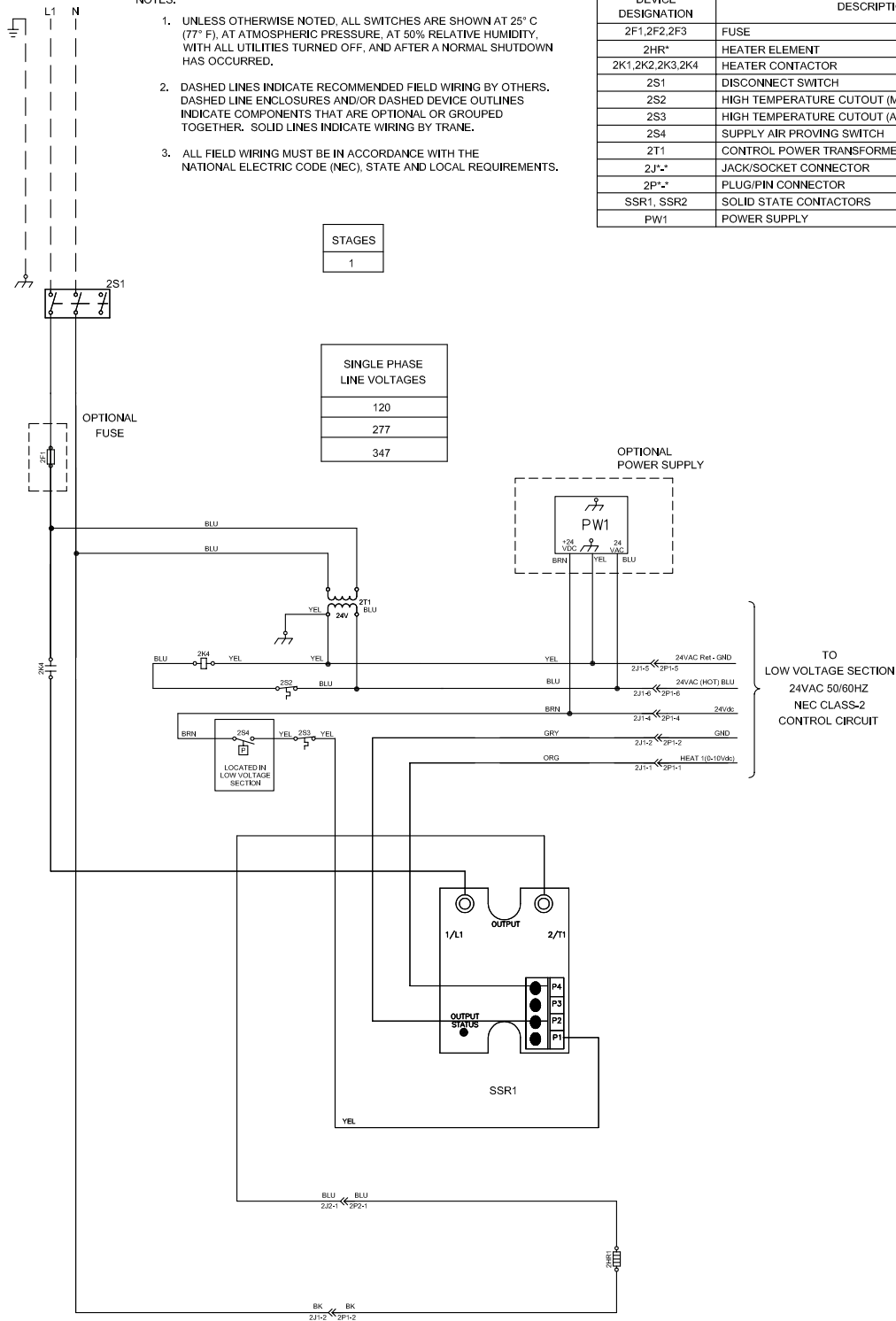

STAGES
1

SINGLE PHASE LINE VOLTAGES
120
277
347

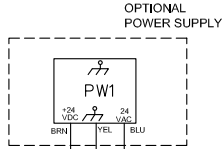

TO
LOW VOLTAGE SECTION
24VAC 50/60HZ
NEC CLASS-2
CONTROL CIRCUIT



Wiring Diagrams

Figure 30. Single duct, single phase, SCR, 2 legs, 1 stage

STAGES
1

SINGLE PHASE LINE VOLTAGES
208
240
480

LINE VOLTAGE
(SEE NAMEPLATE)

NOTES:

1. UNLESS OTHERWISE NOTED, ALL SWITCHES ARE SHOWN AT 25° C (77° F), AT ATMOSPHERIC PRESSURE, AT 50% RELATIVE HUMIDITY, WITH ALL UTILITIES TURNED OFF, AND AFTER A NORMAL SHUTDOWN HAS OCCURRED.
2. DASHED LINES INDICATE RECOMMENDED FIELD WIRING BY OTHERS. DASHED LINE ENCLOSURES AND/OR DASHED DEVICE OUTLINES INDICATE COMPONENTS THAT ARE OPTIONAL OR GROUPED TOGETHER. SOLID LINES INDICATE WIRING BY TRANE.
3. ALL FIELD WIRING MUST BE IN ACCORDANCE WITH THE NATIONAL ELECTRIC CODE (NEC), STATE AND LOCAL REQUIREMENTS.

LEGEND	
DEVICE DESIGNATION	DESCRIPTION
2F1,2F2,2F3	FUSE
2HR*	HEATER ELEMENT
2K1,2K2,2K3,2K4	HEATER CONTACTOR
2S1	DISCONNECT SWITCH
2S2	HIGH TEMPERATURE CUTOUT (MANUAL RESET)
2S3	HIGH TEMPERATURE CUTOUT (AUTO RESET)
2S4	SUPPLY AIR PROVING SWITCH
2T1	CONTROL POWER TRANSFORMER
2J*.*	JACK/ SOCKET CONNECTOR
2P*.*	PLUG/PIN CONNECTOR
SSR1, SSR2	SOLID STATE CONTACTORS
PW1	POWER SUPPLY

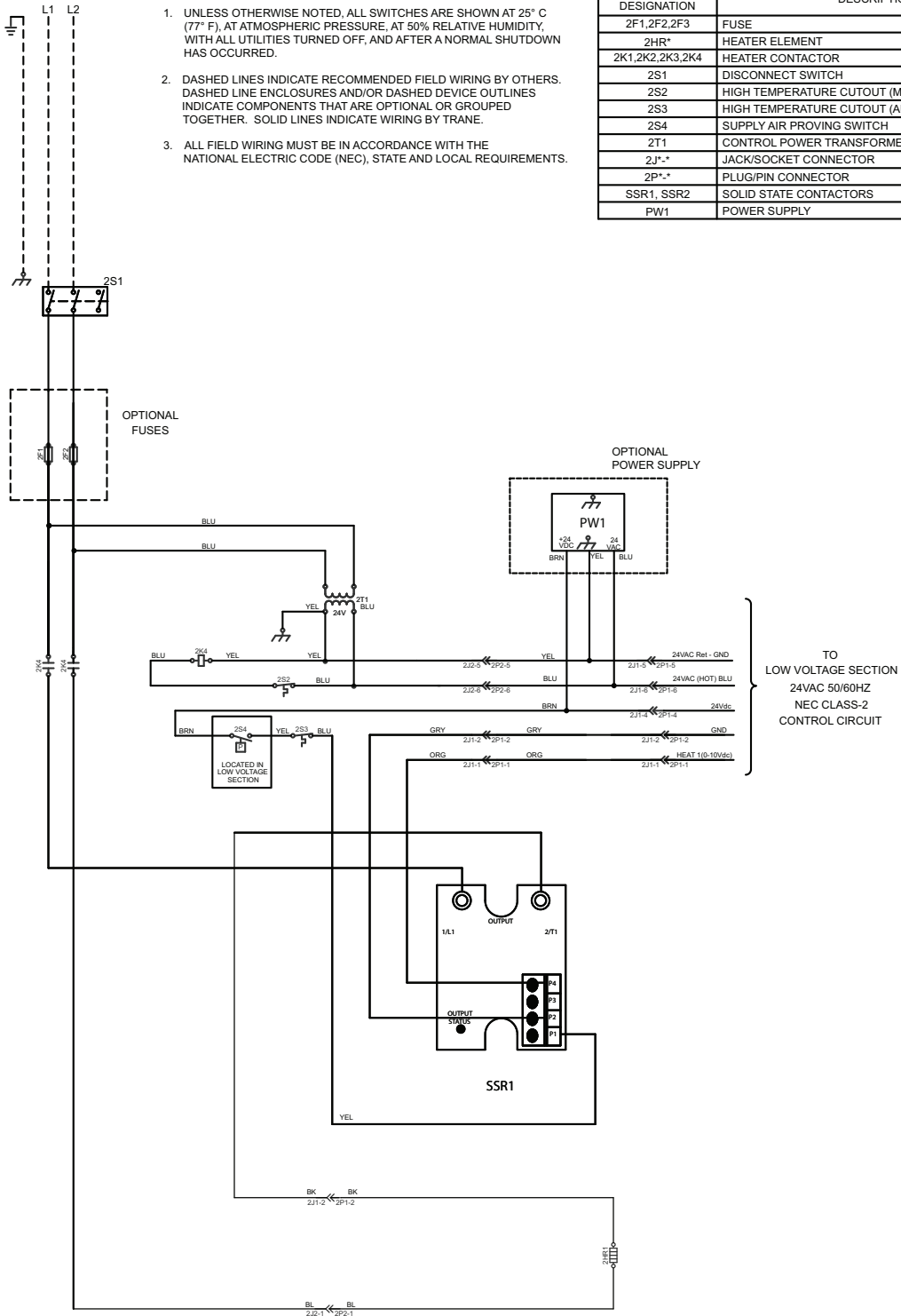

Figure 31. Single duct, three phase, delta, SCR, 1 stage

STAGES
1

SINGLE PHASE LINE VOLTAGES
208
240
480

LINE VOLTAGE
(SEE NAMEPLATE)

NOTES:

1. UNLESS OTHERWISE NOTED, ALL SWITCHES ARE SHOWN AT 25° C (77° F), AT ATMOSPHERIC PRESSURE, AT 50% RELATIVE HUMIDITY, WITH ALL UTILITIES TURNED OFF, AND AFTER A NORMAL SHUTDOWN HAS OCCURRED.
2. DASHED LINES INDICATE RECOMMENDED FIELD WIRING BY OTHERS. DASHED LINE ENCLOSURES AND/OR DASHED DEVICE OUTLINES INDICATE COMPONENTS THAT ARE OPTIONAL OR GROUPED TOGETHER. SOLID LINES INDICATE WIRING BY TRANE.
3. ALL FIELD WIRING MUST BE IN ACCORDANCE WITH THE NATIONAL ELECTRIC CODE (NEC), STATE AND LOCAL REQUIREMENTS.

LEGEND	
DEVICE DESIGNATION	DESCRIPTION
2F1,2F2,2F3	FUSE
2HR*	HEATER ELEMENT
2K1,2K2,2K3,2K4	HEATER CONTACTOR
2S1	DISCONNECT SWITCH
2S2	HIGH TEMPERATURE CUTOUT (MANUAL RESET)
2S3	HIGH TEMPERATURE CUTOUT (AUTO RESET)
2S4	SUPPLY AIR PROVING SWITCH
2T1	CONTROL POWER TRANSFORMER
2J*-*	JACK/SOCKET CONNECTOR
2P*-*	PLUG/PIN CONNECTOR
SSR1, SSR2	SOLID STATE CONTACTORS
PW1	POWER SUPPLY

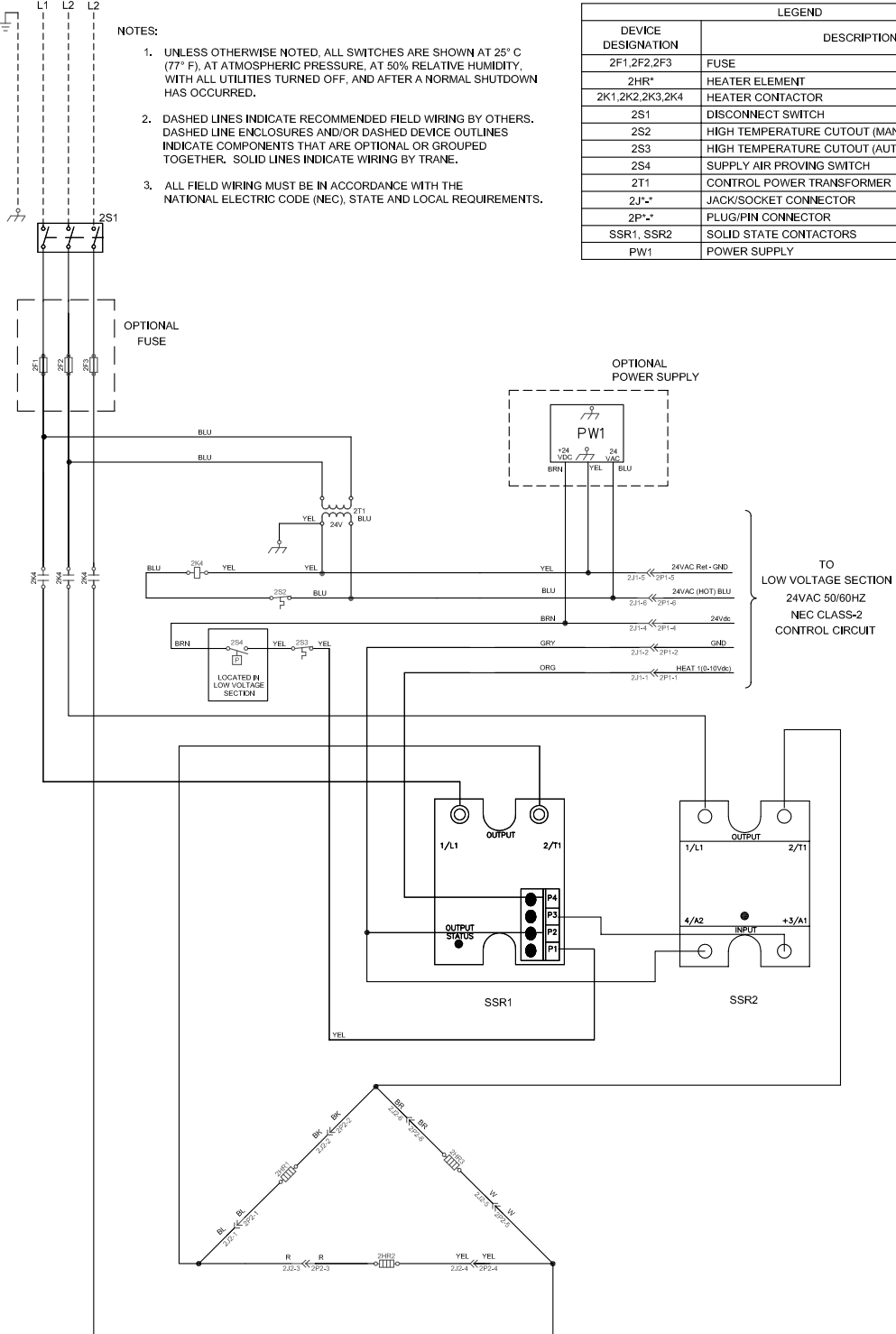

Figure 32. Single duct, single phase, 1 leg

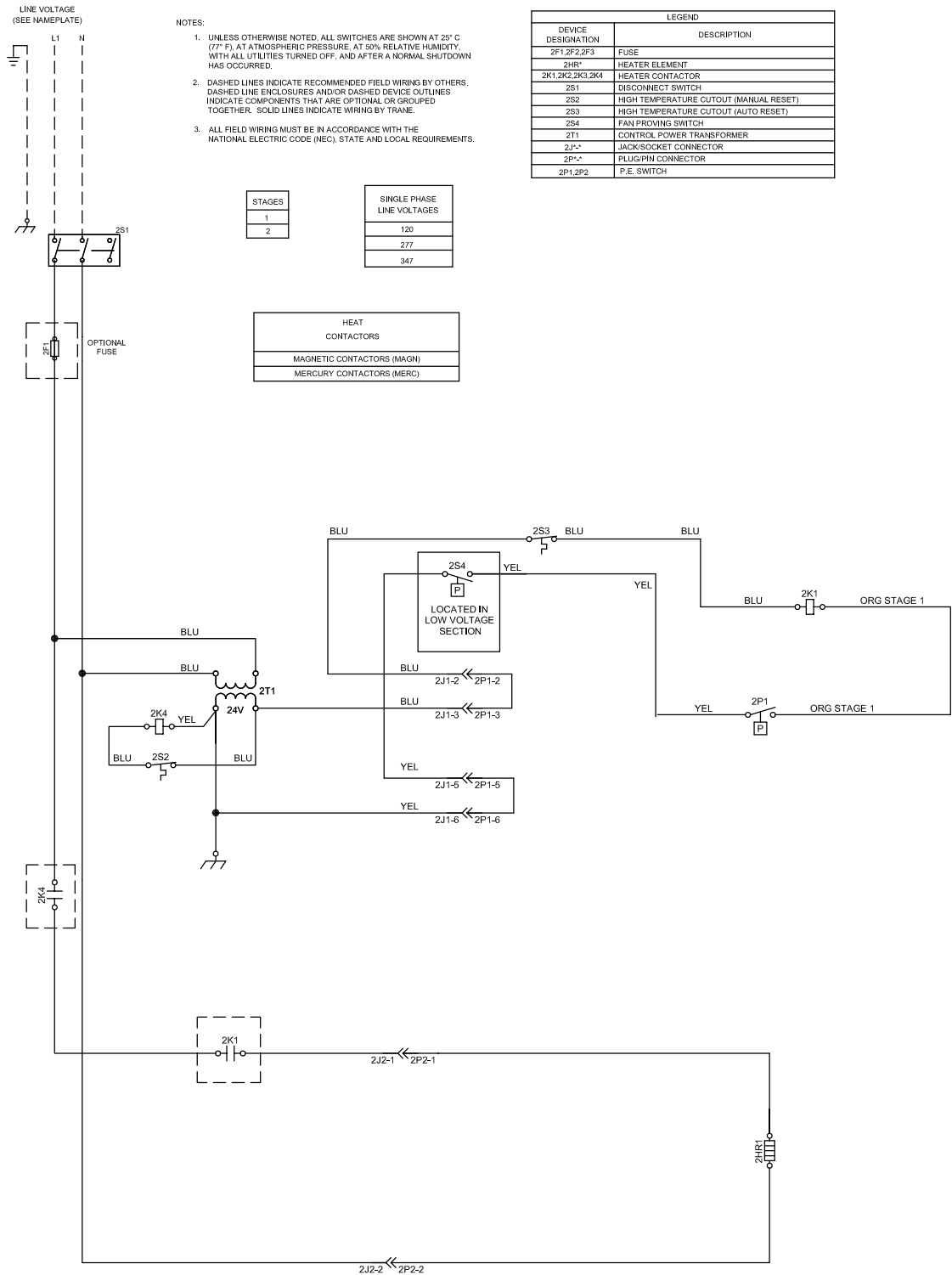
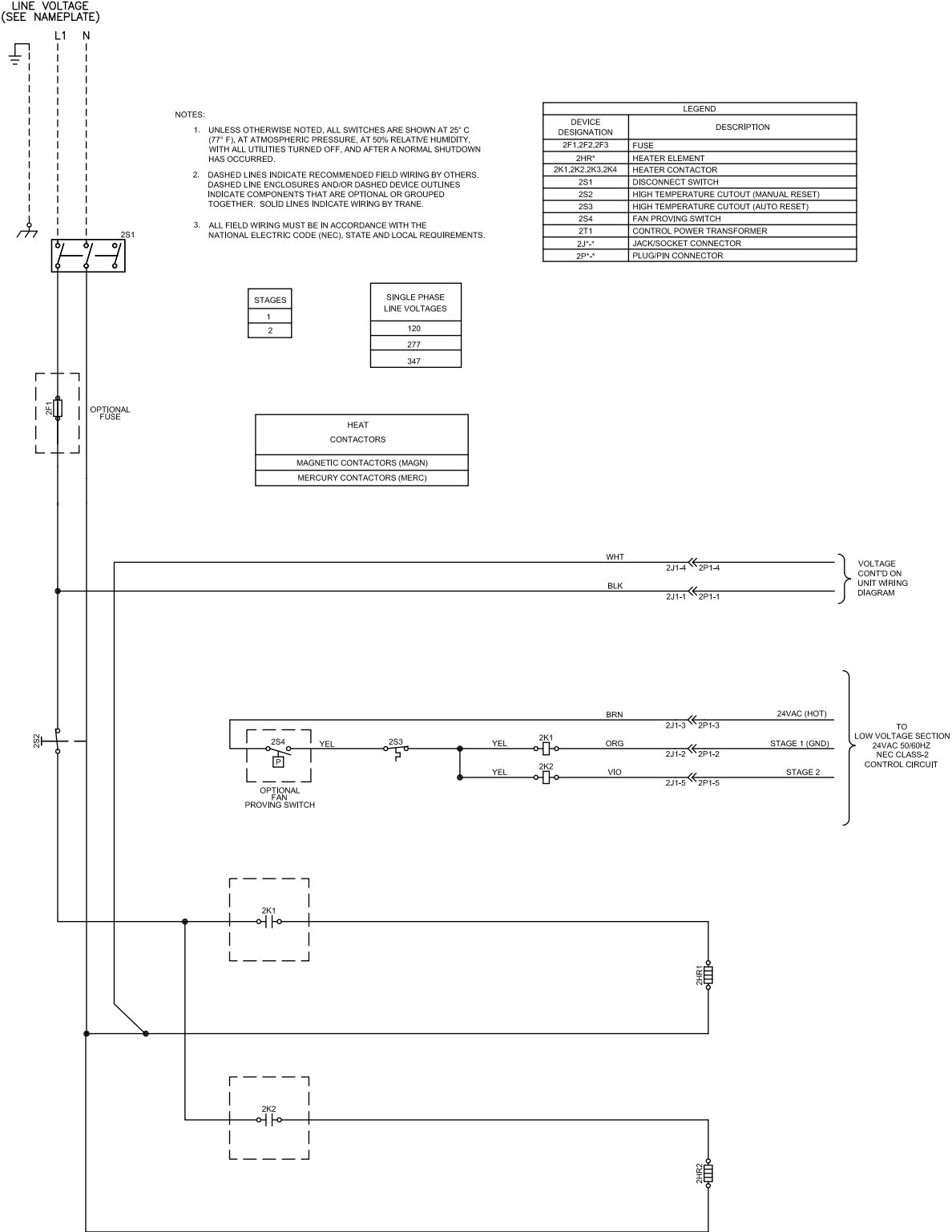

Figure 33. Fan powered, single phase, 1 leg, 2 stages



Wiring Diagrams

Figure 34. Fan powered, single phase, 2 legs, 2 stages

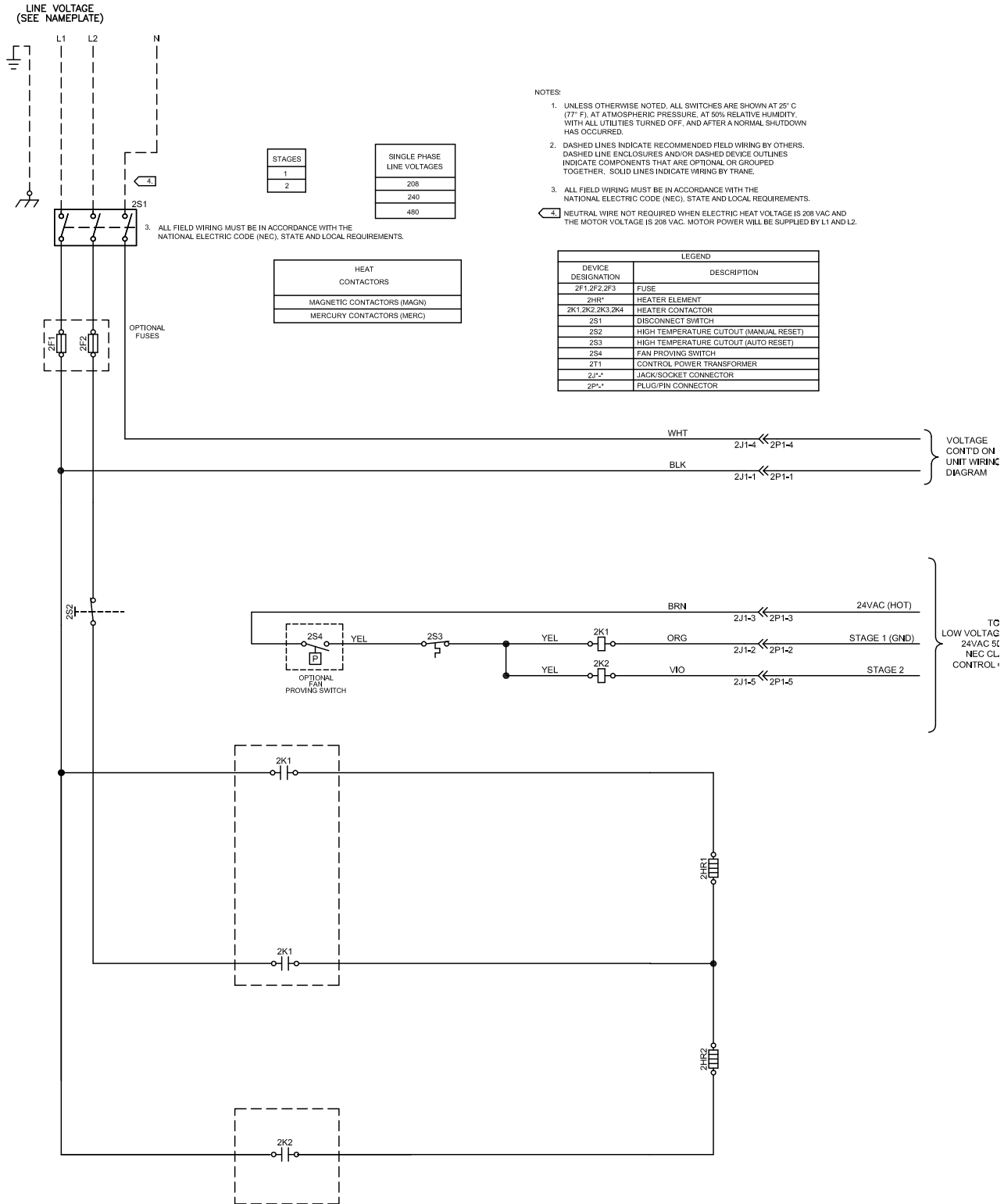

Figure 35. Fan powered, three phase, wye, 2 stages

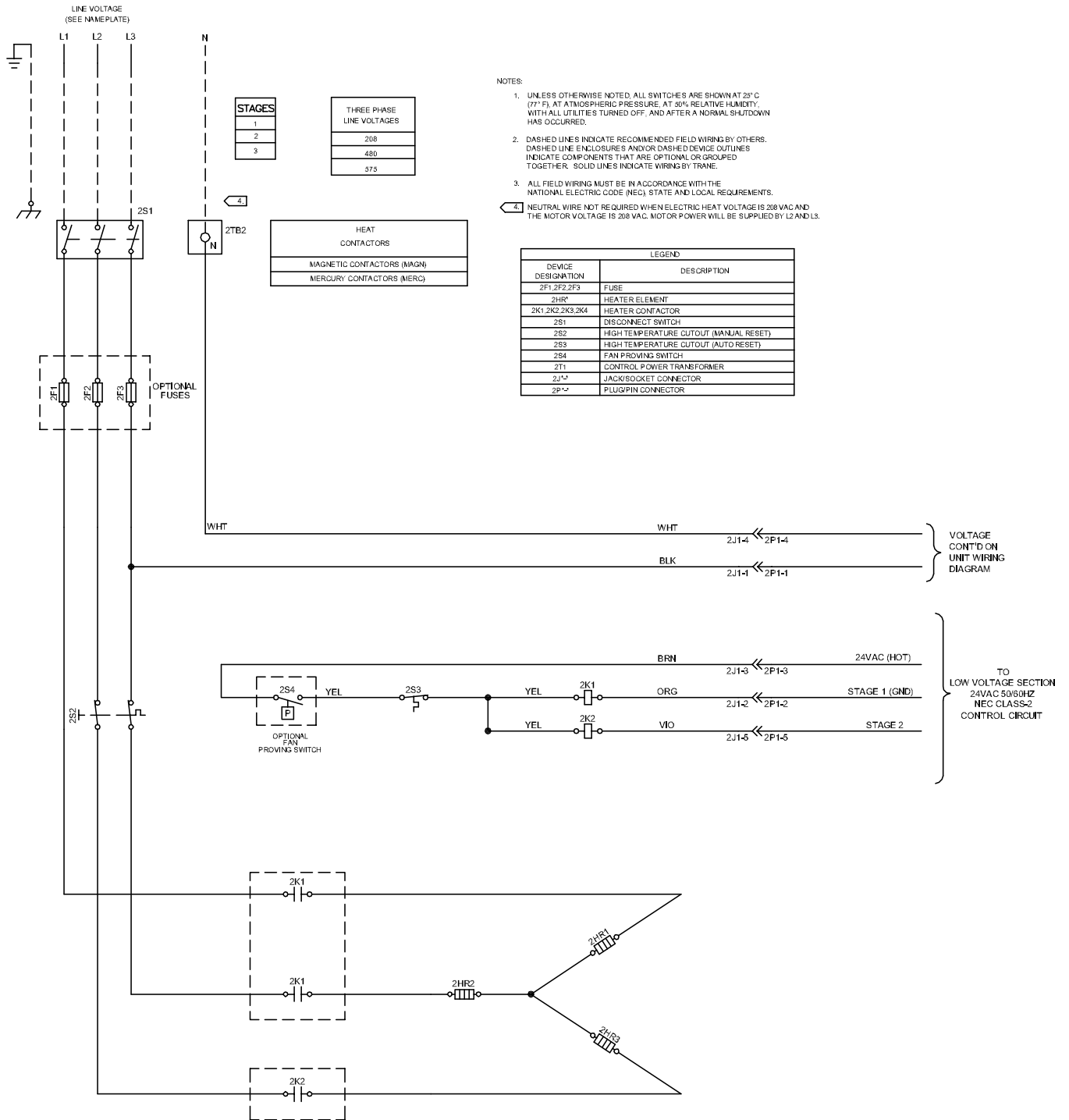

Figure 36. Fan powered, single phase, 1 leg, 2 stages

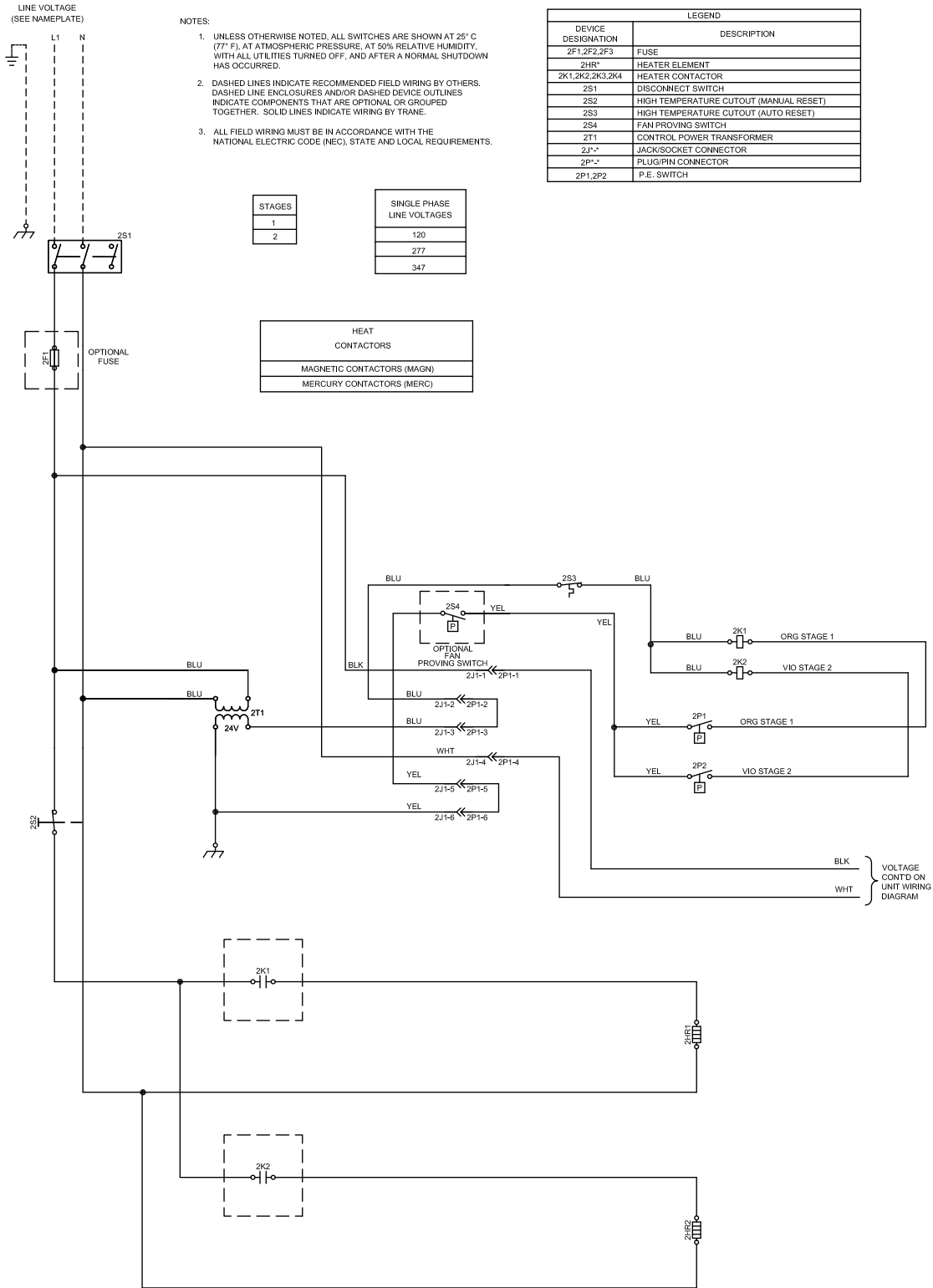

Figure 37. Fan powered, single phase, 2 legs, 2 stages

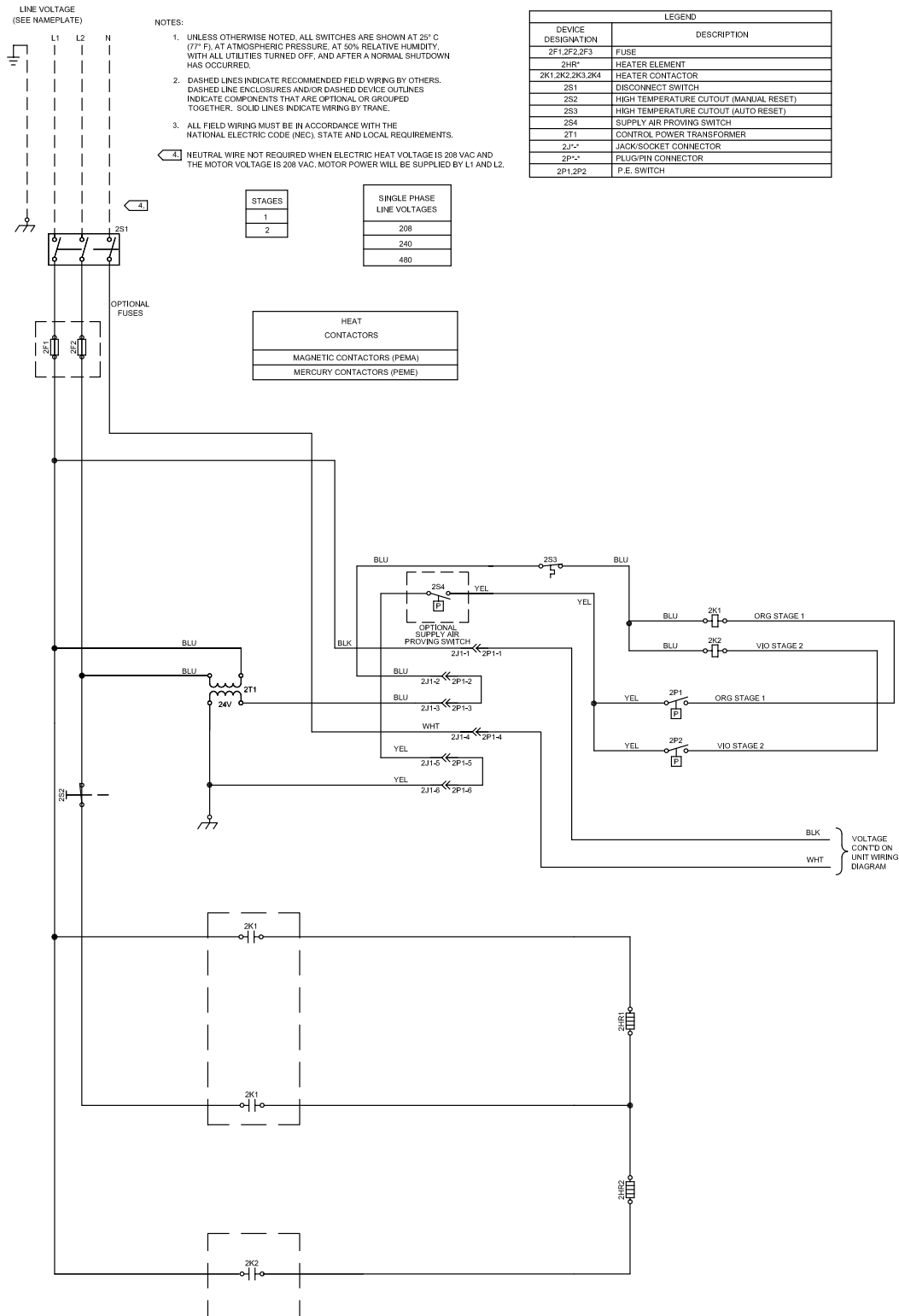
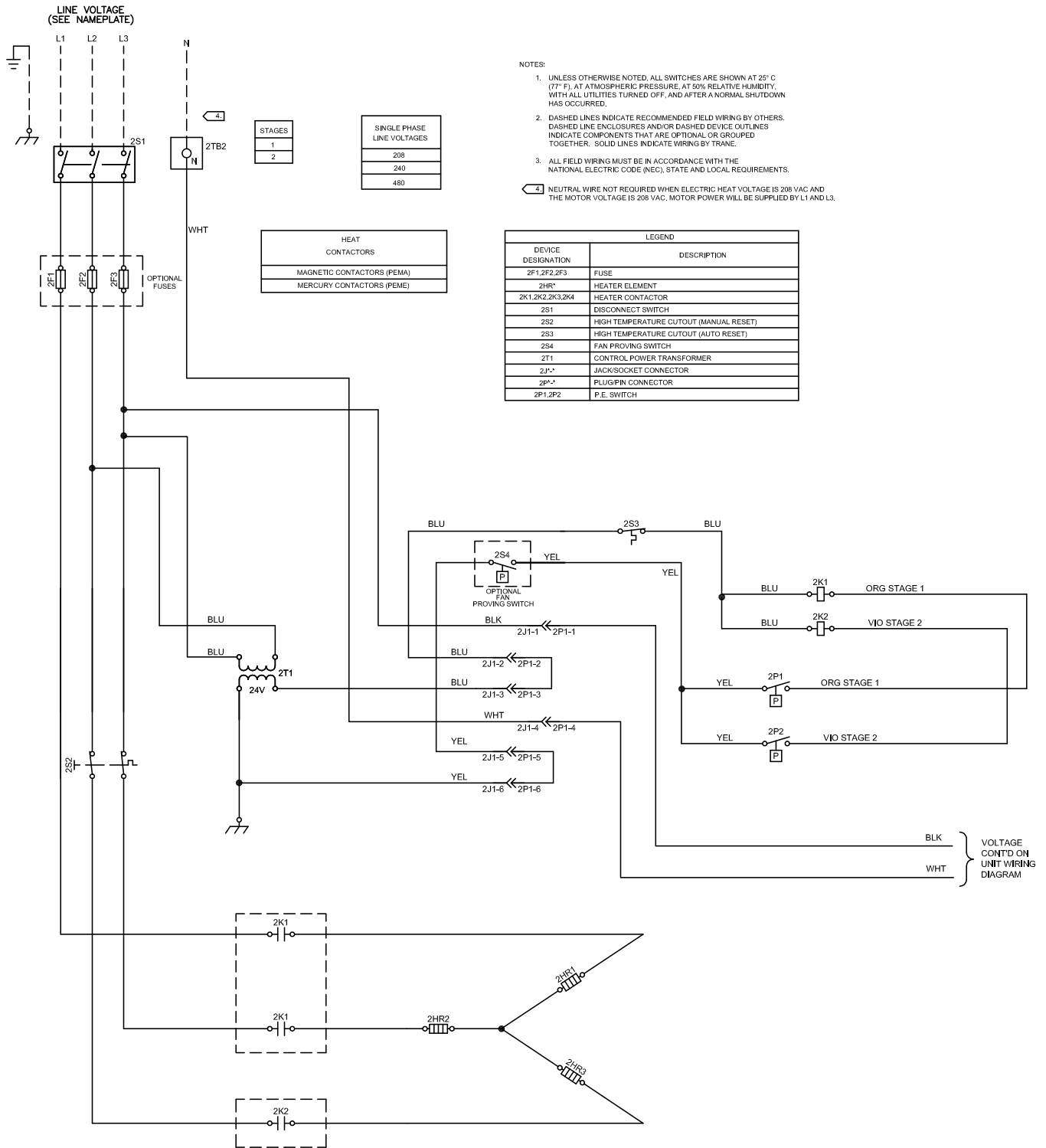

Figure 38. Fan powered, three phase, wye, 2 stages



Control Box Wiring

Figure 39. Single duct control box

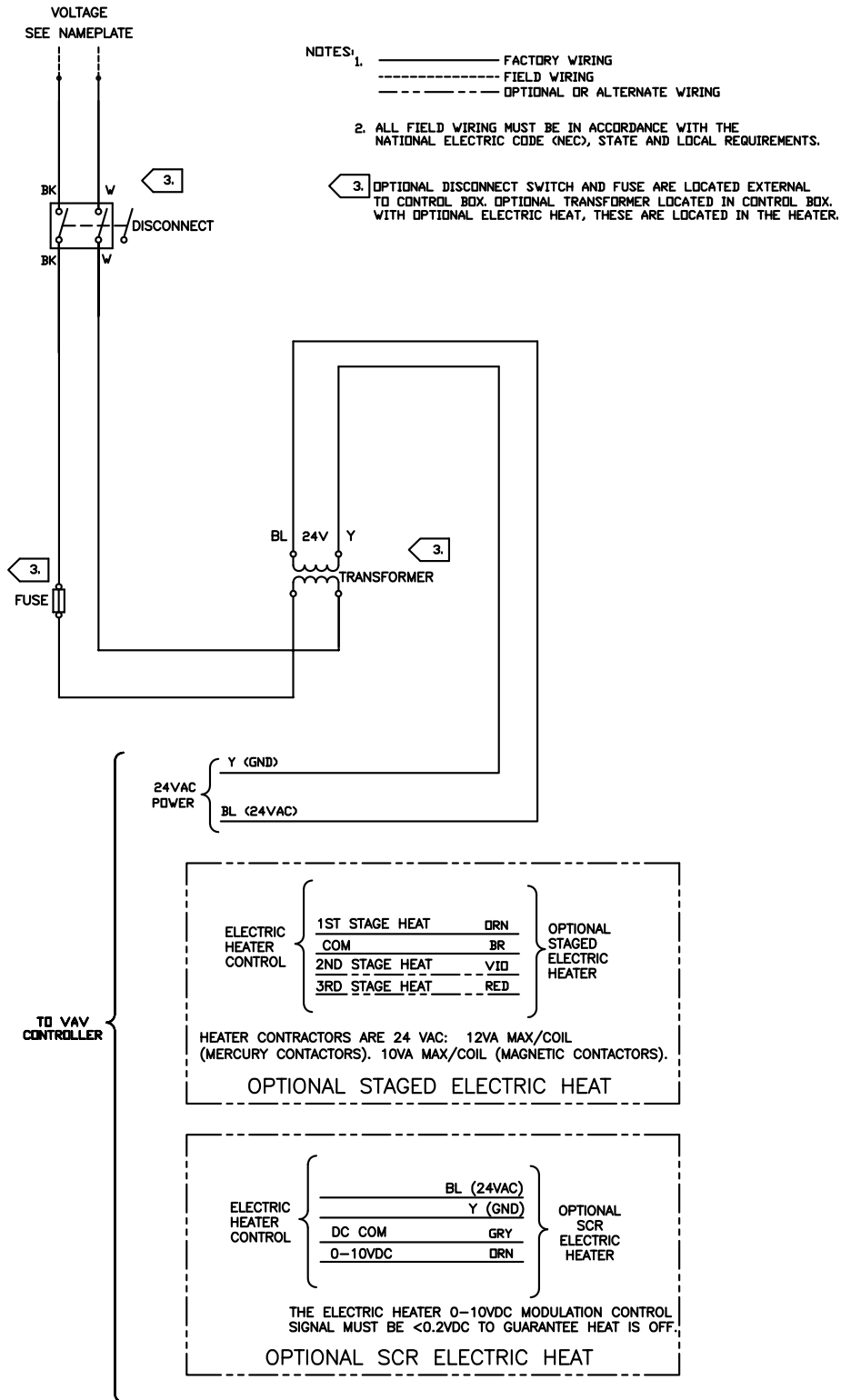

Figure 40. Fan-powered units with PSC motors

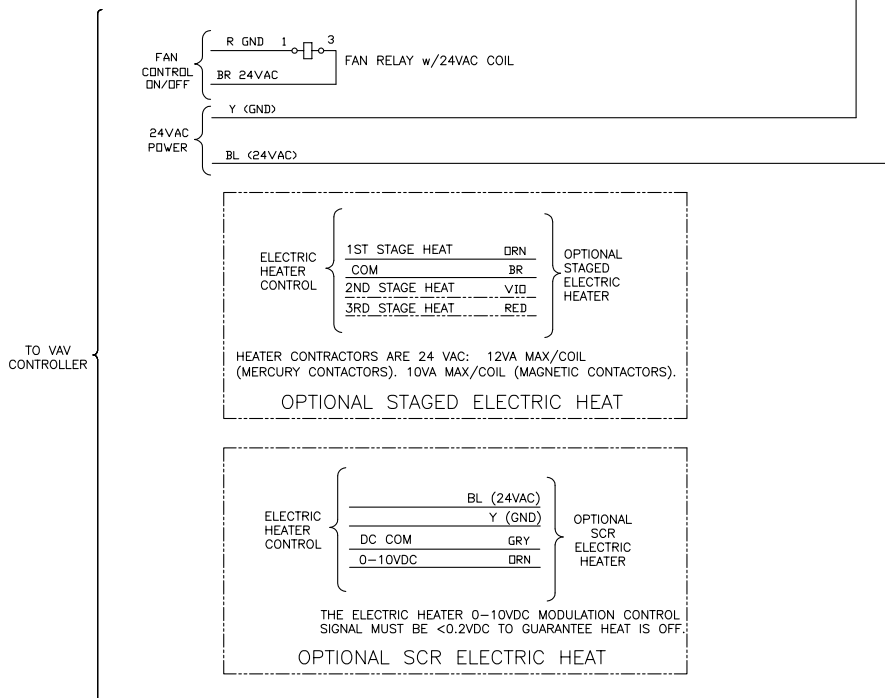
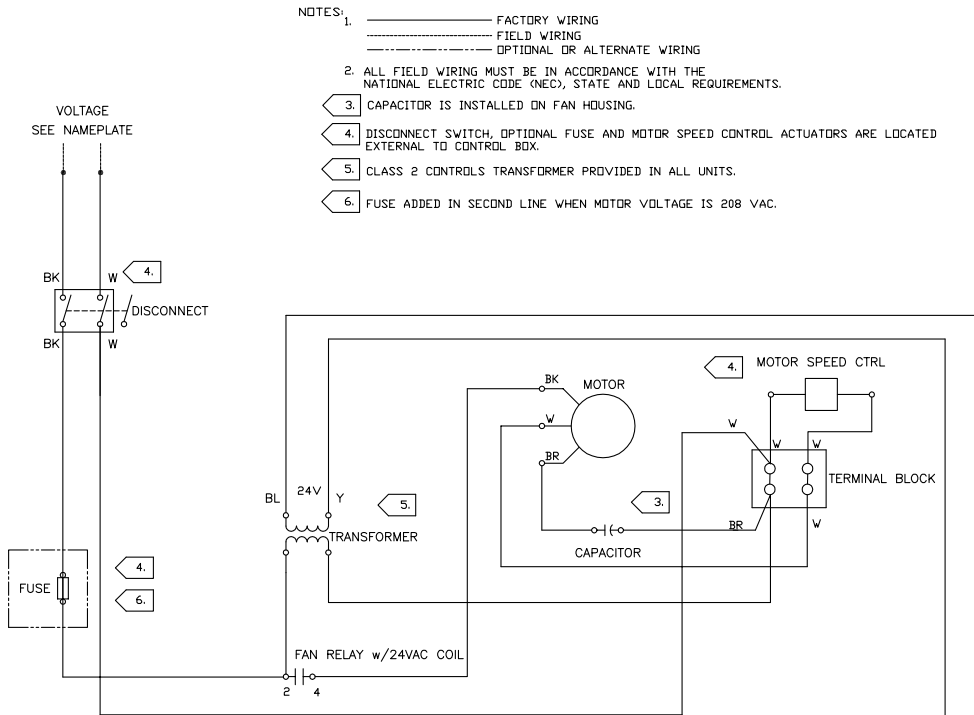

Figure 41. Fan-powered units with ECM motor

NOTES:

1. FACTORY WIRING
2. FIELD WIRING
3. OPTIONAL OR ALTERNATE WIRING
2. ALL FIELD WIRING MUST BE IN ACCORDANCE WITH THE NATIONAL ELECTRIC CODE (NEC), STATE AND LOCAL REQUIREMENTS.
3. OPTIONAL POWER FACTOR CORRECTION CHOKE LOCATED IN CONTROL BOX. (NOT REQUIRED FOR LOW HEIGHT STYLE UNITS)
4. DISCONNECT SWITCH, FUSE AND MOTOR SPEED CONTROL ACTUATORS ARE LOCATED EXTERNAL TO CONTROL BOX.
5. CLASS 2 CONTROLS TRANSFORMER PROVIDED IN ALL UNITS.
6. FUSE ADDED IN SECOND LINE WHEN MOTOR VOLTAGE IS 208 VAC.

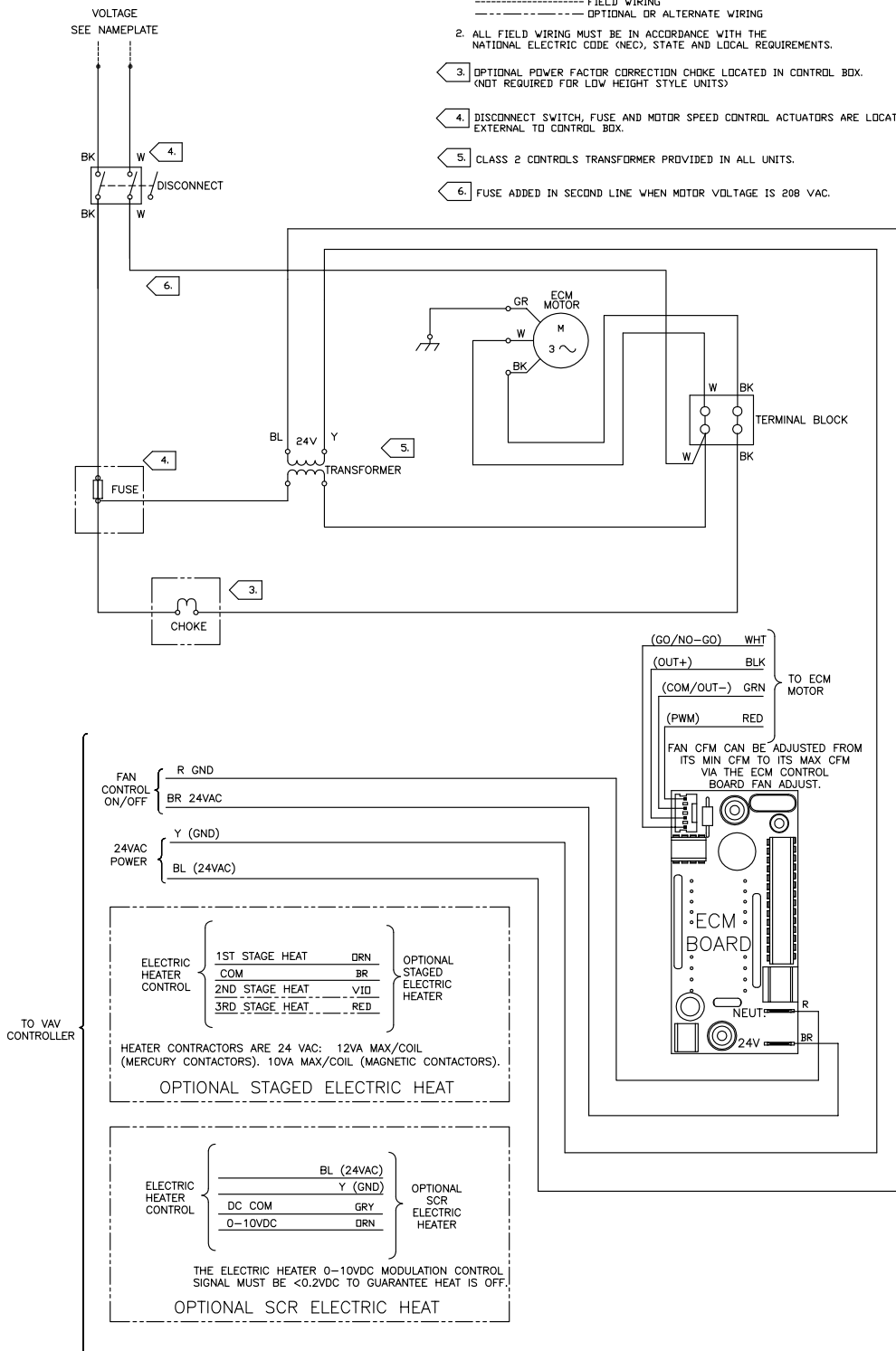

Figure 42. Fan-powered units with ECV motor

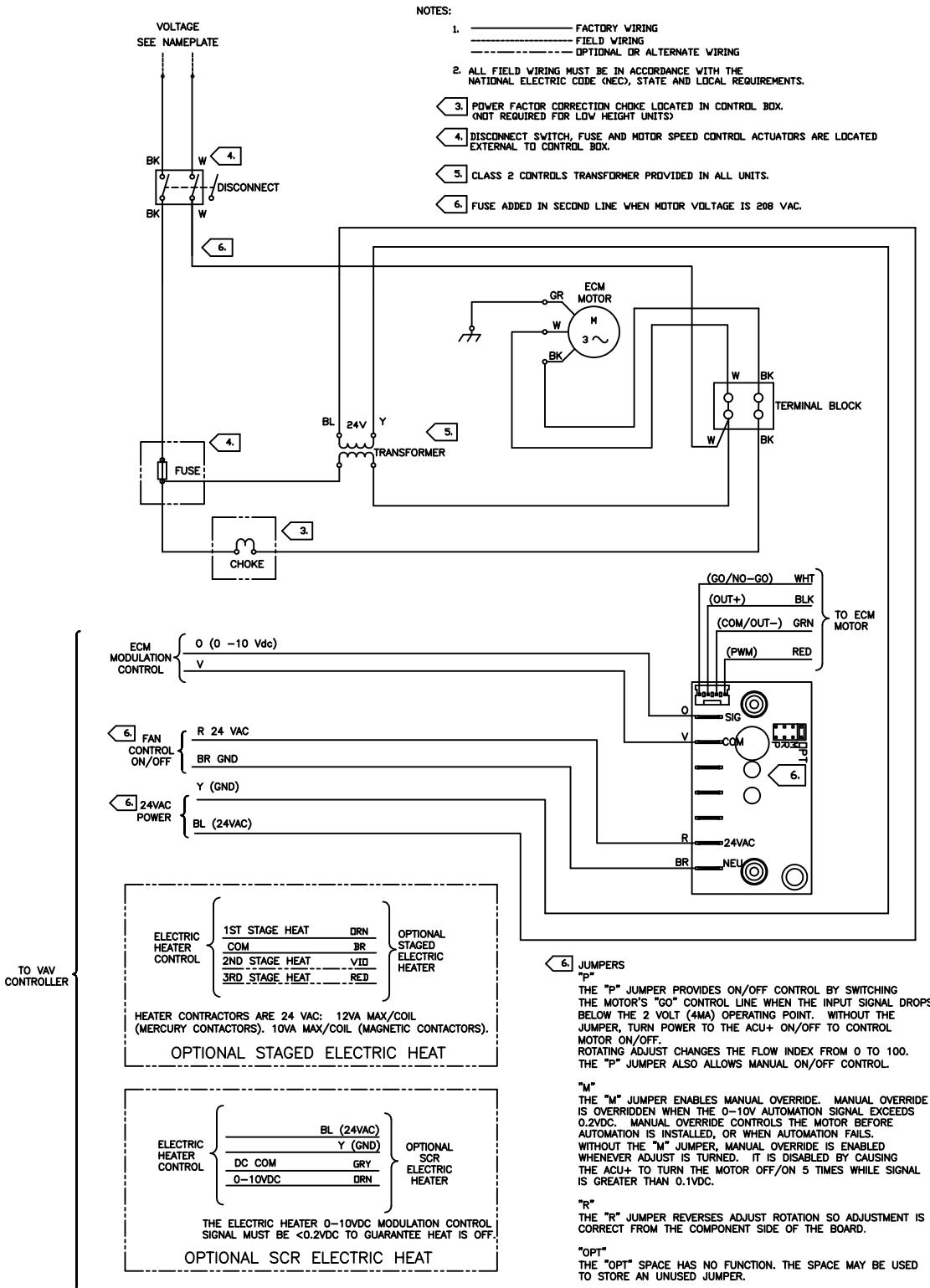
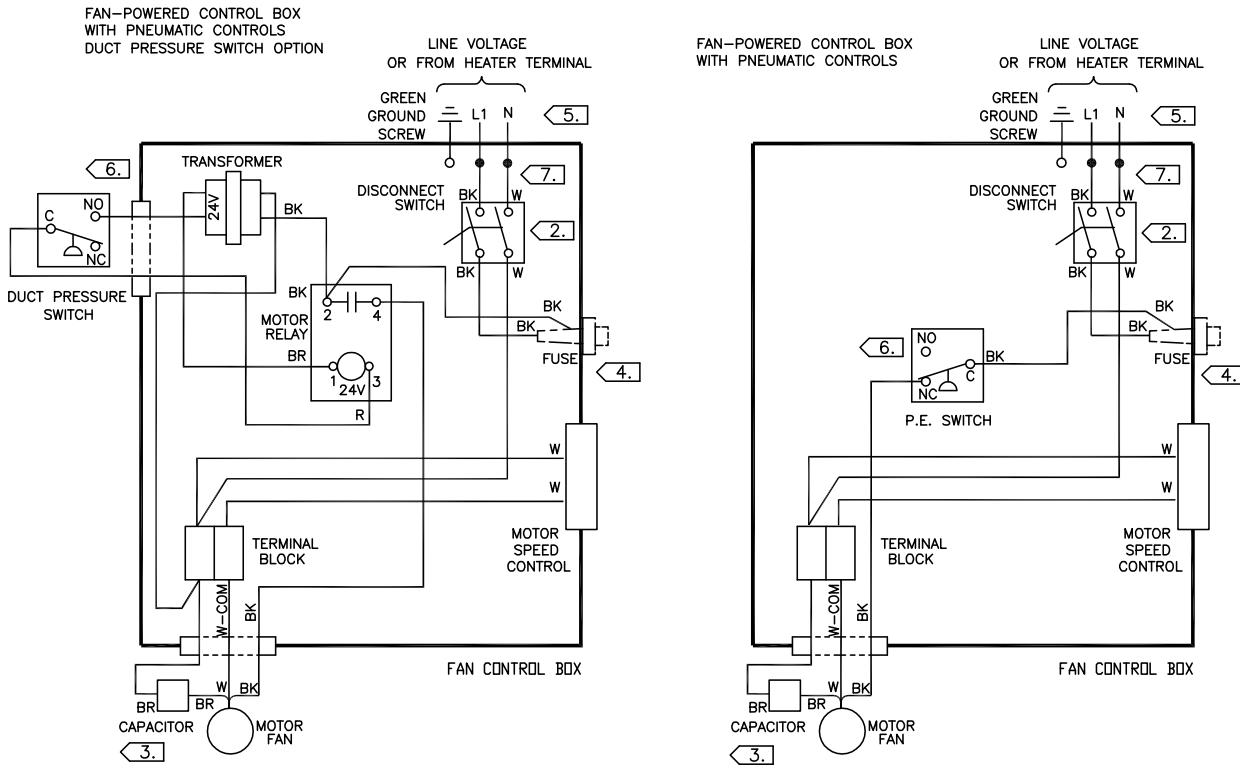

Figure 43. Fan-powered, old style



NOTES:

- 1. _____ FACTORY INSTALLED
 - - - - - BY OTHERS
 - - - - - OPTIONAL OR ALTERNATE CIRCUITRY
- 2. DISCONNECT SWITCH, FUSE, & SCR ARE LOCATED EXTERNAL TO CONTROL BOX.
- 3. CAPACITOR IS INSTALLED ON FAN HOUSING.
- 4. FUSE IS OPTIONAL.
- 5. DETERMINED BY MOTOR VOLTAGE ON ORDER. VOLTAGE FOUND ON UNIT NAMEPLATE.
- 6. FOR SERIES FAN POWERED TERMINAL UNITS ONLY.
- 7. NEUTRAL WIRE NOT REQUIRED WHEN ELECTRIC HEAT VOLTAGE IS 208 VAC AND MOTOR VOLTAGE IS 208VAC. MOTOR POWER WILL BE SUPPLIED BY L1 AND L2.

WARNING

HAZARDOUS VOLTAGE!
 DISCONNECT, LOCK OUT AND TAG ALL ELECTRIC POWER INCLUDING REMOTE DISCONNECTS BEFORE SERVICING.
 DISCHARGE MOTOR START/RUN CAPACITORS BEFORE SERVICING.
 FAILURE TO DISCONNECT POWER BEFORE SERVICING CAN CAUSE SEVERE PERSONAL INJURY OR DEATH.

CAUTION

USE COPPER CONDUCTORS ONLY!
 UNIT TERMINALS ARE NOT DESIGNED TO ACCEPT OTHER TYPES OF CONDUCTORS.
 FAILURE TO DO SO MAY CAUSE DAMAGE TO THE EQUIPMENT.

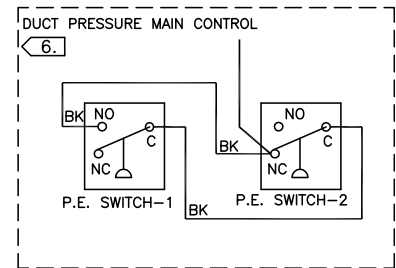
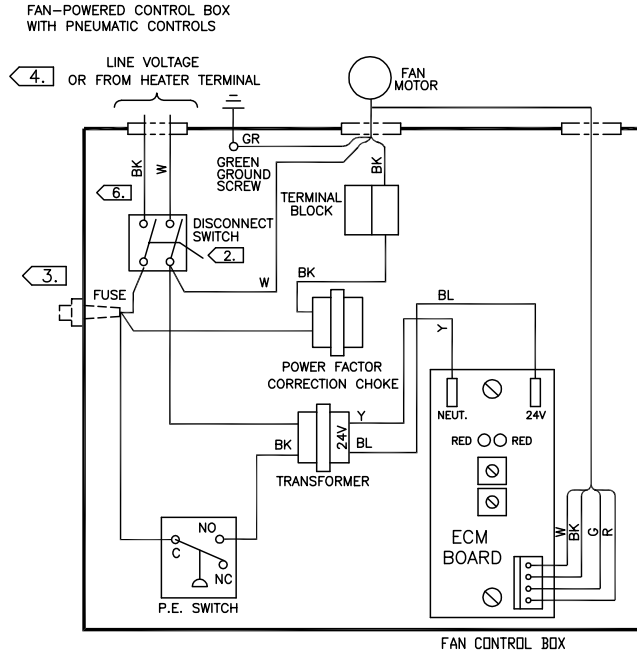
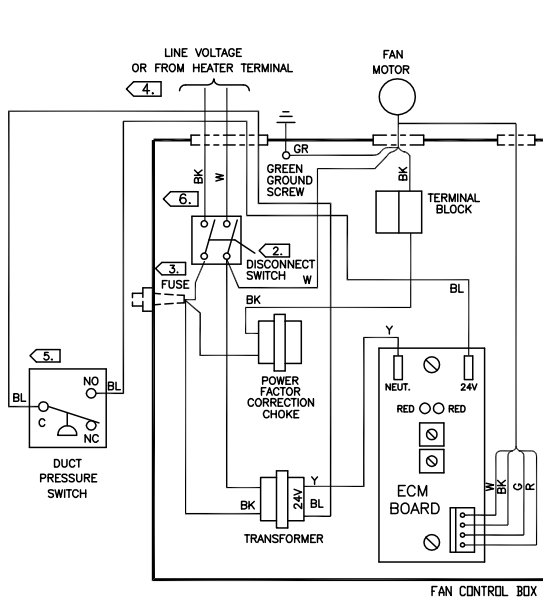

Figure 44. Fan-powered, ECM, old style

FAN-POWERED CONTROL BOX w/ECM
WITH PNEUMATIC CONTROLS
DUCT PRESSURE SWITCH OPTION



NOTES:

1. ————— FACTORY INSTALLED
 - - - - - BY OTHERS
 - · - · - · OPTIONAL OR ALTERNATE CIRCUITRY
2. DISCONNECT SWITCH, FUSE, & SCR ARE LOCATED EXTERNAL TO CONTROL BOX.
3. FUSE IS OPTIONAL.
4. DETERMINED BY MOTOR VOLTAGE ON ORDER. VOLTAGE FOUND ON UNIT NAMEPLATE.
5. FOR SERIES FAN POWERED TERMINAL UNITS ONLY.
6. FUSE ADDED IN SECOND LINE WHEN MOTOR VOLTAGE IS 208 VAC.

⚠ WARNING

HAZARDOUS VOLTAGE!
DISCONNECT, LOCK OUT AND TAG ALL ELECTRIC POWER INCLUDING REMOTE DISCONNECTS BEFORE SERVICING.

DISCHARGE MOTOR START/RUN CAPACITORS BEFORE SERVICING.
FAILURE TO DISCONNECT POWER BEFORE SERVICING CAN CAUSE SEVERE PERSONAL INJURY OR DEATH.

⚠ CAUTION

USE COPPER CONDUCTORS ONLY!
UNIT TERMINALS ARE NOT DESIGNED TO ACCEPT OTHER TYPES OF CONDUCTORS.
FAILURE TO DO SO MAY CAUSE DAMAGE TO THE EQUIPMENT.

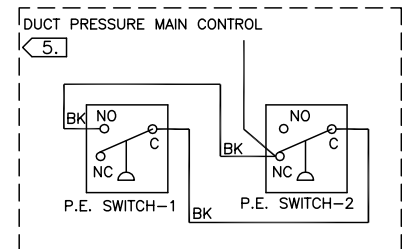
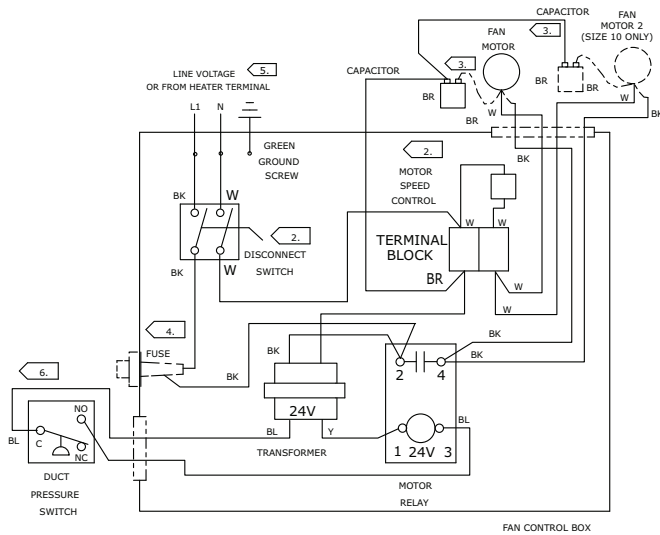
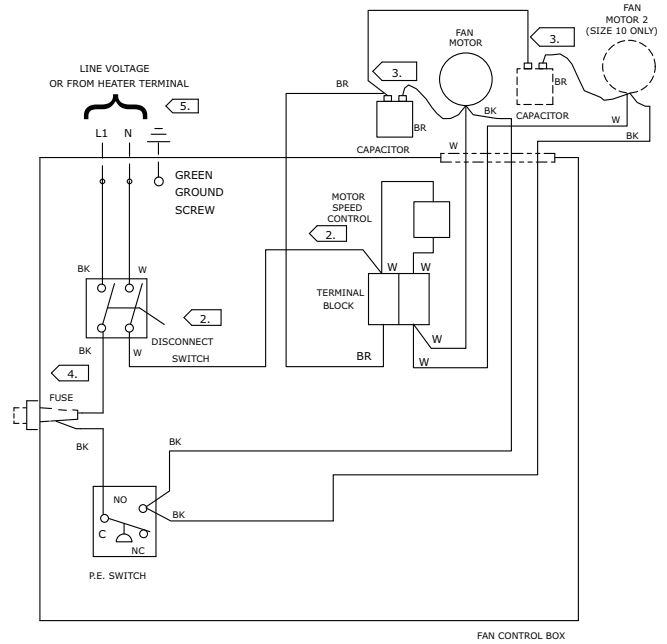

Figure 45. Fan-powered, low-height incl 10SQ, old style

Fan-Powered Low-Height Control Box
Duct Pressure Switch Option



Fan-Powered Low-Height Control Box



NOTES:

- 1. ————— FACTORY INSTALLED
 - - - - - BY OTHERS
 ······ OPTIONAL OR ALTERNATE CIRCUITRY
- 2. DISCONNECT SWITCH, FUSE, & SCR ARE LOCATED EXTERNAL TO CONTROL BOX.
- 3. CAPACITOR IS INSTALLED ON FAN HOUSING.
- 4. FUSE IS OPTIONAL.
- 5. DETERMINED BY MOTOR VOLTAGE ON ORDER. VOLTAGE FOUND ON UNIT NAMEPLATE.
- 6. FOR SERIES FAN POWERED TERMINAL UNITS ONLY.

⚠ WARNING

HAZARDOUS VOLTAGE!
DISCONNECT, LOCK OUT AND TAG ALL ELECTRIC POWER INCLUDING REMOTE DISCONNECTS BEFORE SERVICING.

DISCHARGE MOTOR START/RUN CAPACITORS BEFORE SERVICING.
FAILURE TO DISCONNECT POWER BEFORE SERVICING CAN CAUSE SEVERE PERSONAL INJURY OR DEATH.

⚠ CAUTION

USE COPPER CONDUCTORS ONLY!
UNIT TERMINALS ARE NOT DESIGNED TO ACCEPT OTHER TYPES OF CONDUCTORS.
FAILURE TO DO SO MAY CAUSE DAMAGE TO THE EQUIPMENT.

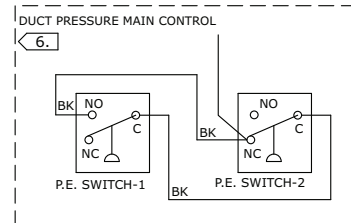

Wiring Diagrams

Figure 46. Fan-powered, low-height incl 10SQ, ECM, old style

Fan-Powered Low-Height Control Box
w/ ECM with Electronic or DDC Controls
(Depending on the size of the unit, the ECM board
may or may not be located in the fan control box.)

Fan-Powered Low-Height Control Box
w/ ECM
Duct Pressure Switch Option

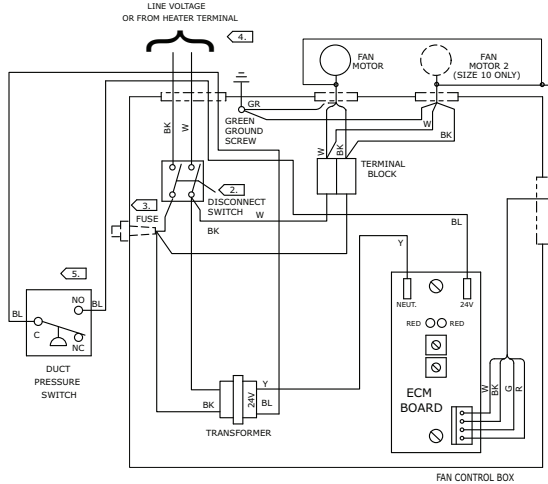
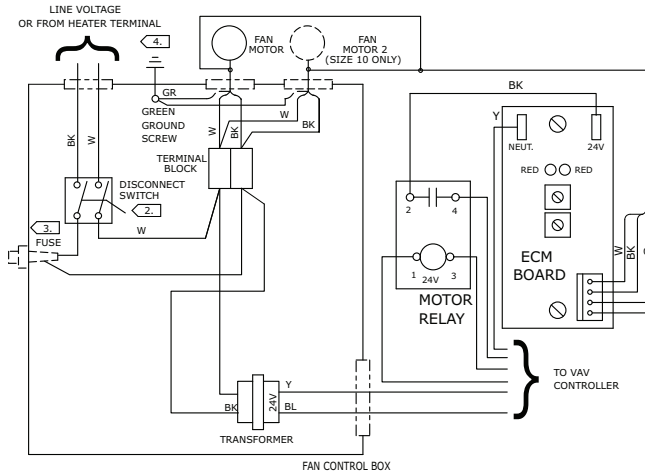

⚠ WARNING
HAZARDOUS VOLTAGE!
DISCONNECT, LOCK OUT AND TAG ALL ELECTRIC POWER INCLUDING REMOTE DISCONNECTS BEFORE SERVICING.
DISCHARGE MOTOR START/RUN CAPACITORS BEFORE SERVICING.
FAILURE TO DISCONNECT POWER BEFORE SERVICING CAN CAUSE SEVERE PERSONAL INJURY OR DEATH.

⚠ CAUTION
USE COPPER CONDUCTORS ONLY!
UNIT TERMINALS ARE NOT DESIGNED TO ACCEPT OTHER TYPES OF CONDUCTORS.
FAILURE TO DO SO MAY CAUSE DAMAGE TO THE EQUIPMENT.

Fan-Powered Low-Height Control Box w/ ECM

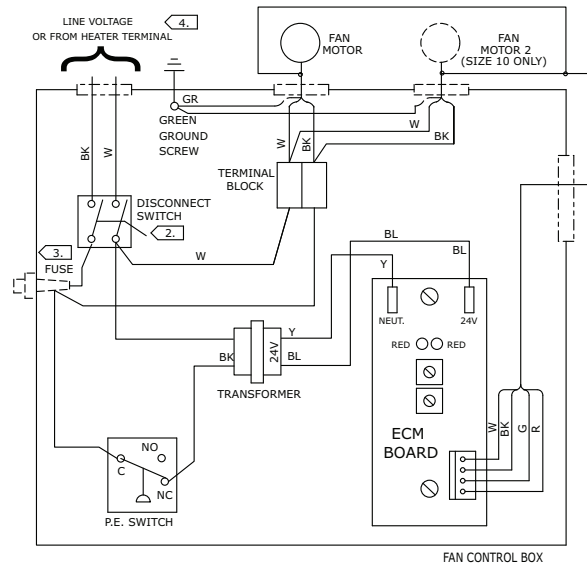

NOTES:

1. ———— FACTORY INSTALLED
----- BY OTHERS
----- OPTIONAL OR ALTERNATE CIRCUITRY
2. DISCONNECT SWITCH, FUSE, & SCR ARE LOCATED EXTERNAL TO CONTROL BOX.
3. FUSE IS OPTIONAL.
4. DETERMINED BY MOTOR VOLTAGE ON ORDER. VOLTAGE FOUND ON UNIT NAMEPLATE.
5. FOR SERIES FAN POWERED TERMINAL UNITS ONLY.



Maintenance

Periodic maintenance of the VariTrane™ product is minimal, but necessary for efficient operation. Routine maintenance consists of inspecting/replacing the air filters of the fan-powered terminals.

Motors

Both the Permanent Split Capacitor (PSC) and the Electrically Commutated Motor (ECM) require no lubrication during its normal life of operation.

Fan Wheel

Routinely inspect the fan wheel for dirt or debris and cleaned as necessary.

Filter

Routinely inspect and/or replace the filter on fan-powered terminals depending on the environmental conditions of the plenum.

Filter Change Out

- To remove the filter, turn each of the filter retaining clips 90° (CW or CCW)
- Remove the filter and replace with new filter of the same frame size.
- Return the filter clips to their retaining position by turning them 90° (CW or CCW) back to their original position.

Water Coil

- Periodically inspect water coils and clean fins.
- Water coils are provided with an access panel as standard to assist with inspection and cleaning.

Fan Motor Replacement

<p>⚠ WARNING</p> <p>Hazardous Voltage w/Capacitors!</p> <p>Failure to disconnect power and discharge capacitors before servicing could result in death or serious injury.</p> <p>Disconnect all electric power, including remote disconnects and discharge all motor start/run capacitors before servicing. Follow proper lockout/tagout procedures to ensure the power cannot be inadvertently energized. For variable frequency drives or other energy storing components provided by Trane or others, refer to the appropriate manufacturer's literature for allowable waiting periods for discharge of capacitors. Verify with a CAT III or IV voltmeter rated per NFPA 70E that all capacitors have discharged.</p>
--

Figure 47. Standard motor removal

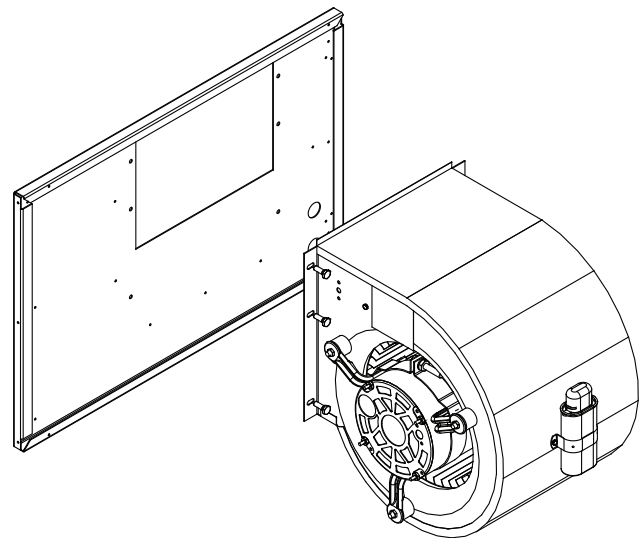

Standard height fan-powered series and parallel fan motors are replaceable through the filter opening and the standard sliding side access panel. To access the fan motor, the fan housing must be detached by removing the mounting bolts that hold the housing to the fan board. Removing the entire housing allows the fan motor, fan housing, and fan wheel to be re-aligned on a workbench or floor and prevent any possible fan wheel rubbing that may occur. Removing the housing will provide access to the motor shaft set screw that holds the fan wheel to the motor shaft.

The low height fan assembly has been designed to be removed and replaced as a complete unit.

SCR Assembly

SCR solid state relays are used to switch a single heater stage on and off. An intelligent (Master) relay is used for all single phase applications. For three phase applications, a Master-Slave configuration is used to switch two legs of three phase power to the heater stage. The Master Relay controls one leg independently, and provides a control signal to the Slave Relay, which controls the second leg.

Figure 48. Typical heat sink fin orientation

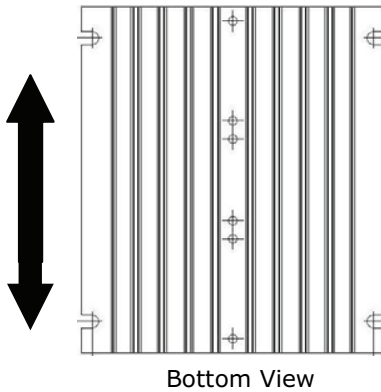

Every Master or Master/Slave relay combination is mounted on a heat sink to prevent the relays from

overheating during normal operation. The SCR assembly must always be mounted with the heat sink fins oriented vertically (see above) with a minimum clearance of 0.5 inches on all sides of the heat sink for cooling. Where additional cooling slots are provided in the heater, the VAV unit must be mounted with a minimum of 1 inch clearance in front of the slots.

When the 0-10 VDC control voltage is present at the Master relay in both single and three phase applications, an ON indicating LED light on the Master relay will blink continually (approximately 0.5 seconds on, 1.0 seconds off). If the load side voltage is also present at the relay(s), the Master relay LED and the Slave relay LED blink rate will increase as the control signal increases. When the control signal reaches a maximum of 10 VDC, all LEDs will be lit continuously, indicating that the relays are full-open and continuously conducting. If the control signal is present in three phase applications while the load side voltage is not, only the Master relay LED will light and the blink rate will be constant.

If the SCR assembly does not appear to be functioning properly, verify that all required voltages are present and all that all wiring is properly connected. If all these conditions are verified, and the SCR LED does not light and/or the SCR relay does not conduct, the entire SCR heat sink assembly should be changed out. Individual Master or Slave relays should not be replaced.

Trane - by Trane Technologies (NYSE: TT), a global innovator - creates comfortable, energy efficient indoor environments for commercial and residential applications. For more information, please visit trane.com or tranetechnologies.com.

Trane has a policy of continuous product and product data improvements and reserves the right to change design and specifications without notice. We are committed to using environmentally conscious print practices.

VAV-SVX08U-EN 05 Mar 2022
Supersedes VAV-SVX08T-EN (December 2021)

©2022 Trane