



Evans Cooling Systems, Inc.  
255 Gay Street  
Sharon, CT 06069

## INSTALLATION PROCEDURE – 2011 Navistar MaxxForce 13L

### Procedure for installing Evans Waterless Coolant and a ResistorPac into a 2011 Navistar Max Force 13L engine equipped with an ECM-controlled modulating fan

VER 05Nov2012

#### **CAUTIONARY NOTE: DO NOT FLUSH COOLING SYSTEM WITH WATER!**

This procedure is modeled on NFI Truck No. 222013 VIN 3HSDHSJR1CN453484

Coolant temperature sensor: Navistar P/N 62274210190  
Thermostats (2): Navistar P/N 3006444C3  
Fan clutch: Prob Horton V-Master Ultra 12THX (ECM-controlled modulating)  
No sleeper  
No APU  
No fuel or tank heaters  
No SCR system (no DEF)

In this procedure a 55 Ohm ResistorPac is placed in series with the coolant temperature sensor, raising the temperature algorithm for the fan and raising the derating temperature by making the ECM “think” the coolant temperature is cooler than it really is. The coolant temperature gauge is driven from the ECM and will read the temperature that the ECM thinks it sees. The actual coolant temperature will be approximately 20° F warmer than the gauge reads.

#### **1. Supplies, information, and special tools needed:**

- a. Obtain this information from the owner:
  - 1) What are the year, make and model of the truck?
  - 2) What is the VIN?
  - 3) Is the engine equipped with a coolant filter?
- b. Purchase these items from an International dealer:
  - 1) If the engine is equipped with a coolant filter, a non-chemical coolant filter element. A Fleetguard WF2077 fits.
  - 2) **Two new thermostats P/N: 3006444C3.** (This procedure requires that the thermostats be removed for blowing out old coolant. Putting in new thermostats assures that the sealing rings won't leak. The thermostats are only about \$18 each.)
- c. The following items are sourced from Evans Cooling Systems, Inc.: 888-990-2665
  - 1) Evans waterless coolant: Evans Heavy Duty Formula (improved HDTC). 18 gallons is needed for a day cab without an APU unit and without fuel tank heaters. (16 gallons for the engine + 1 gallon for flushing + 1 gallon for spare to carry.)  
Additional coolant will be needed if there are additional circuits requiring coolant.

- 2) Evans-provided labels to warn against the addition of water.
  - 3) One Evans P/N RP2-C55-IN2-0830 ResistorPac.
  - 4) Refractometer for measuring small amounts of water content – Evans P/N E2190.
  - 5) An Evans “Water-Chaser” P/N E2195, a device useful for inserting coolant for flushing.
  - 6) An Evans P/N E2195H Flex Extension for Makita blower (see d. below)
  - d. A high-volume air source (rather than high pressure) such as Makita blower Model UB 1101, widely available from the internet.
  - e. An angled pick for difficult hoses.
  - f. Small picks and screwdrivers for opening the 96-pin ECM plug.
  - g. Funnels.
  - h. A 4” piece of 3/8” id hose and a 3/8” dia. bolt to close one end of it.
  - i. A tennis ball (see 13. e.)
2. **Beginning the procedure** - If the engine is hot, wait for it to cool to a safe temperature. Never open a cooling system pressure cap if the engine is hot.
  3. Place containers to catch coolant at draining locations.
  4. Remove the pressure cap.
  5. There are two radiators to be drained (see diagram, page 6). The container for the primary radiator should be large enough to contain at least 17 gallons. The container for the “Low Temperature” radiator only needs to collect 2 gallons or so but should be wide enough to collect drips over a 2 square ft. area.
    - a. Primary radiator: Drain from the petcock on the right side.
    - b. Low Temp radiator: This radiator is in front of the primary radiator. Find its petcock on the left side.



**PETCOCK FOR LOW TEMP RADIATOR**

- c. Apply air to the expansion tank, either from the Makita blower or from the cooling system pressure tester to speed the draining.
  - d. Once the draining from the primary radiator slows, **pull off the bottom radiator hose and leave it to drain.** Leave the radiator petcocks open.
6. The following devices have “source” connections and “return” connections:
    - Cab heater
    - Sleeper heater

- Fuel tank heaters
- Fuel heater (at fuel filter)
- APU units
- This engine has no DEF tank or DEF tank heater.

The returns all connect to the inlet side of the pump. In general, when air is blown into the source side of each device, old coolant is pushed out of the device, through its return line, and out the bottom radiator hose. **Evans waterless coolant is then introduced into each source side and blown through to chase residual coolant from each device.** Use the Makita blower and the Water-Chaser for these operations.

8. Special device information:

- Cab and sleeper heaters, in order to be drained properly, require that the temperature controls for these units be turned to MAX, the blowers turned ON, and the key ON.
- The coolant to fuel tank heaters generally passes through a thermostatically controlled valve (sometimes labeled “Arctic”) that is probably closed. The connections must be opened downstream of the valve to blow out the coolant in the fuel tank heaters.
- An APU unit may hold significant amounts of old coolant. In general, the air is blown into the outlet of the APU back through the unit and out the inlet side. There may be a thermostat in the APU that requires removal in order to blow coolant out of the unit.
- The transmission oil cooler may be in the bottom of the primary radiator but look for the possibility of a transmission cooler that uses engine coolant that would need to be drained.

9. Turn off the key (if it is still on).

10. Remove the coolant filter, leaving the inlet and outlet valves open.

11. Disconnect hose to the low temp radiator at the CMV.

- Blow air through the low temp radiator and chase with coolant.
- Blow air downward through the CMV.
- Re-attach hose at the CMV.

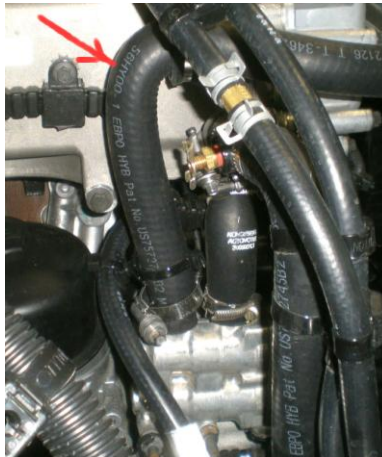

**HOSE TO THE LOW TEMP RADIATOR AT THE CMV**

12. Disconnect hose to LPCAC. Blow air and chase with coolant. Re-attach hose.



HOSE TO LPCAC

13. **Blowing air through the thermostat holes.**

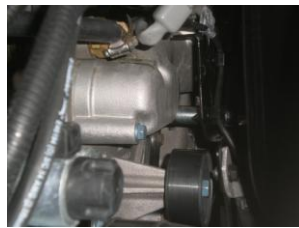

THERMOSTAT HOUSING

- a. Disconnect top radiator hose from primary radiator. Blow air into radiator. Chase with waterless coolant or Prep Fluid. Leave top radiator hose disconnected.
  - b. Remove the bracket that attaches to the fan shroud (3-13mm hex bolts).
  - c. Remove the thermostat cover (3-13mm hex bolts) and the upper radiator hose. Remove the two thermostats, including the sealing rings and discard. **(You have the 2 new thermostats, don't you?)**
  - d. Block the two by-pass holes (they are at the center of each thermostat hole), using a small rag (about 7" x 9") for each. Push against the rags to assure that they won't be going anywhere when air is applied.
  - e. Using the Makita blower and the Flex Extension, blow air into one of the thermostat holes while at the same time using the tennis ball to block the second thermostat hole. Keep blowing air until coolant stops running out the bottom radiator hose.
  - f. **Pull out both rags** and blow air into each side.
  - g. Install the **new** thermostats and the cover.
  - h. Re-attach the top radiator hose.
  - i. Re-install the bracket that attaches to the fan shroud.
14. Install the new non-chemical coolant filter. (Fill it and lubricate the gasket with the waterless coolant.)
15. Re-connect all open hoses. Police all hose connections to assure that they are tight. Close the two radiator petcocks.
16. **Installing the coolant:**

**IMPORTANT! Do not install the coolant using the OEM recommended vacuum filling process. The vacuum filling process will not eliminate air pockets. Here is how you fill the system and end up with no air pockets:**



**IN-HOSE VENT PETCOCK**

- a. Open the in-hose vent petcock.
- b. Pour Evans waterless coolant into the expansion tank to a level above the vent petcock.
- c. Apply air to the expansion tank, either by gentle use of the Makita blower or by use of a cooling system pressure tester.
- d. Hold a small catch can under the vent petcock to catch spurts of coolant.
- e. Add coolant from time to time to keep the level above the petcock.
- f. Keep the petcock open until the emerging coolant is a steady flow; then close it.
- g. Fill the expansion tank with coolant.
- h. Look at the vent lines that enter the expansion tank:

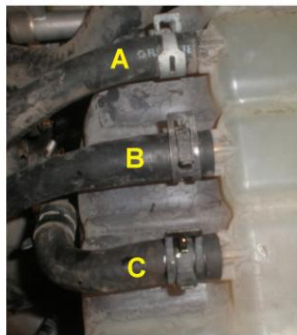

**VENT LINES ENTERING THE EXPANSION TANK**

- i. Pull off vent line A.
- j. Attach the closed 4" hose to the hose nipple for vent line A.
- k. Blow air into the expansion tank until coolant emerges from vent line A.
- l. Re-attach vent line A.
- m. Top up the coolant in the expansion tank.
- n. Repeat the sequence with vent hose C.
- o. Leave vent hose B alone.
- p. Top up the coolant

## 17. Installing ResistorPac P/N RP2-C55-IN2-0830



Shunt      Pigtail      ResistorPac

RP2-C55-IN2-0830 is a ResistorPac kit containing the above components

- Make room to work by removing the air filter box.
- The ResistorPac installs in series with the coolant temperature sensor designated as ECT1 on the diagram (page 8).
- ECT1 is located at the rear of the engine and is difficult to access. The ResistorPac will therefore be installed into the wiring at the ECU.

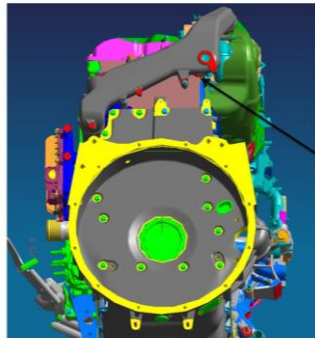

**THE ARROW POINTS TO THE DIFFICULT LOCATION OF THE COOLANT TEMPERATURE SENSOR**

- The signal wire from ECT1 connects to **Pin E1-14** at the ECU. E1 is the 96-pin connector.
- Undo the wiring harness of the 96-hole plug.
- Find the wire that connects to the hole for Pin E1-14 **by removing the back** of the 96-pin plug as follows:
  - Look at the plug carefully. There are 5 visible attachment points that latch the back of the plug to the front, 2 on each side and 1 at the back. **There are 2 more attachment points on each side that are hidden by the lever that actuates the clamping mechanism for attaching the plug to its ECU receptacle.** The lever has to be removed to access the 4 additional latches.
  - With the plug un-plugged, move the lever and observe the slide action. With the lever pointing straight down, mark the position of the slide.
  - The lever is attached on both sides. Lift one of the sides of the lever off its axel by prying carefully. The other side of the lever can now be easily removed.
  - Starting from the wire bundle end, work your way back, unlatching as you go, until the back of the plug can be removed.

- 5) The wire of interest connects to the receptacle for pin 14. The wire is likely blue but may be green or some other color. Cut the wire at a location well clear of the cover. Strip the insulation back about 3/8" on each wire end.
- g. Connect the pigtail to the wire ends of the cut wire using the Waytek butt connectors and crimping. Polarity does not matter. Apply heat to the butt connectors to melt the solder and shrink the insulation.



**THE WIRE TO PIN E1-14**

- h. Snap the back of the plug to its front. Reattach the lever with the lever pointing downward and the slide at its marked position. The first side of the lever goes into position easily and the second side of the lever takes some prying. Check the lever for correct operation. Press the plug into its ECM receptacle and lock it in place.
  - i. Re-install the air filter box.
19. Operate the engine to assure the opening of the thermostats and thorough circulation of the coolant. Add coolant as required to maintain the "hot" level. The system should take 15.75 to 16 gallons (not counting the gallon used for flushing). [Expect that after operating and cool-down cycles additional topping may be required. Make sure that the truck is stocked with an extra gallon and that the driver is advised.]
  20. Apply labels warning against the addition of water or water-based coolant to the cooling system in the vicinity of the expansion tank and on the dashboard..
  21. This procedure is designed for the installed coolant to have 3.0 percent or less water content. Test the water content of the coolant with the Evans refractometer after several operation and cool-down cycles of the engine according to the procedure in the Appendix.

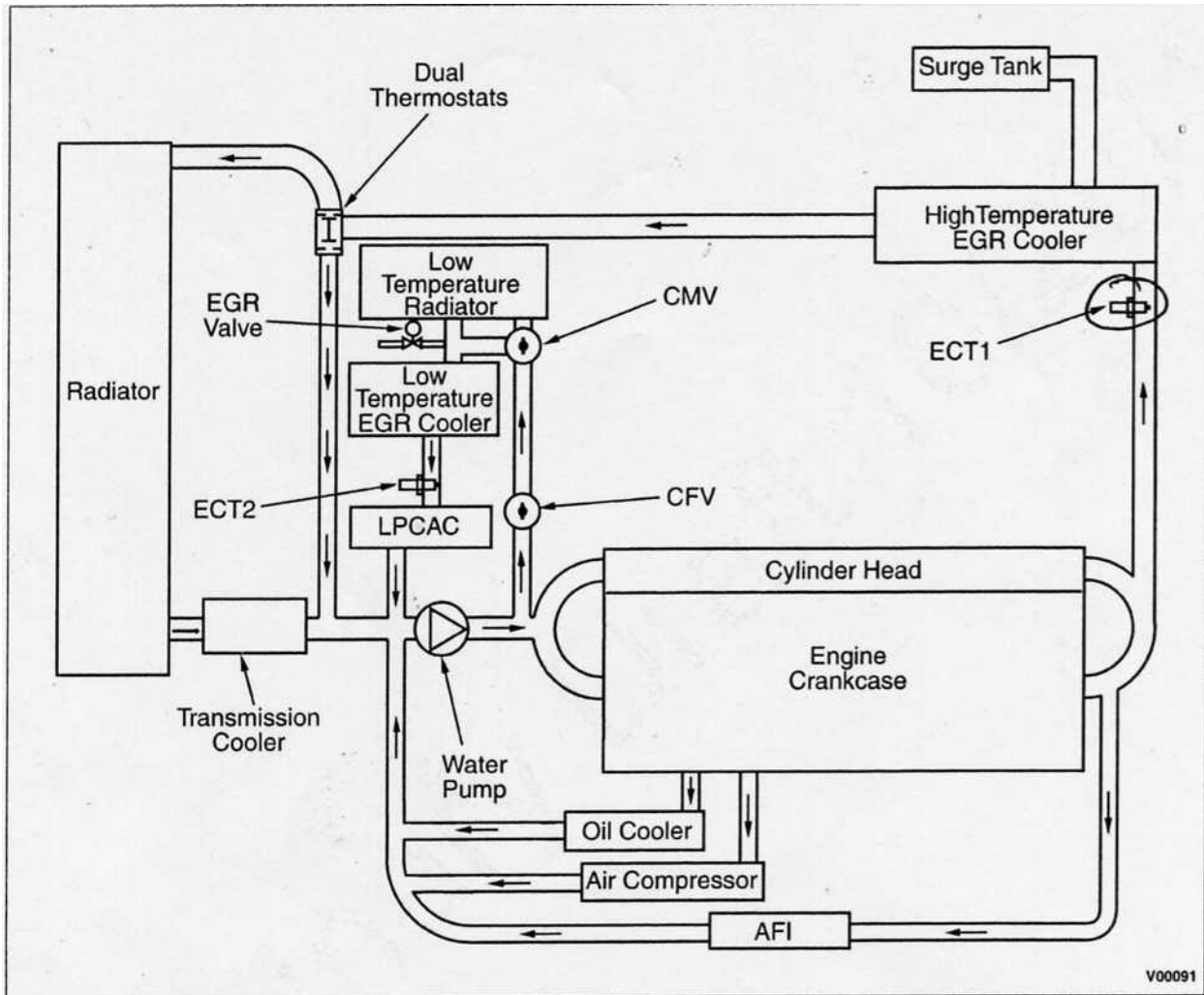

Coolant Flow Diagram for the 2011 Navistar MaxxForce 13L Engine

The procedure contained herein is subject to revision as techniques evolve that speed up the work and that conserve materials. The latest revision can be found on [www.evanscooling.com](http://www.evanscooling.com). Evans Cooling Systems solicits suggestions from installers to help improve the procedures. If you have a suggestion, please call Tom Light 860-435-2418.



## APPENDIX

# Evans Refractometer Part# E2190 for Reading Water Content of Waterless Coolant

VER 10Aug11

### Hand Held Brix Refractometer

Range: 28-62°  
Minimum Division: 0.2°  
Dimensions: 27 x 40 160mm  
Weight: 176 grams

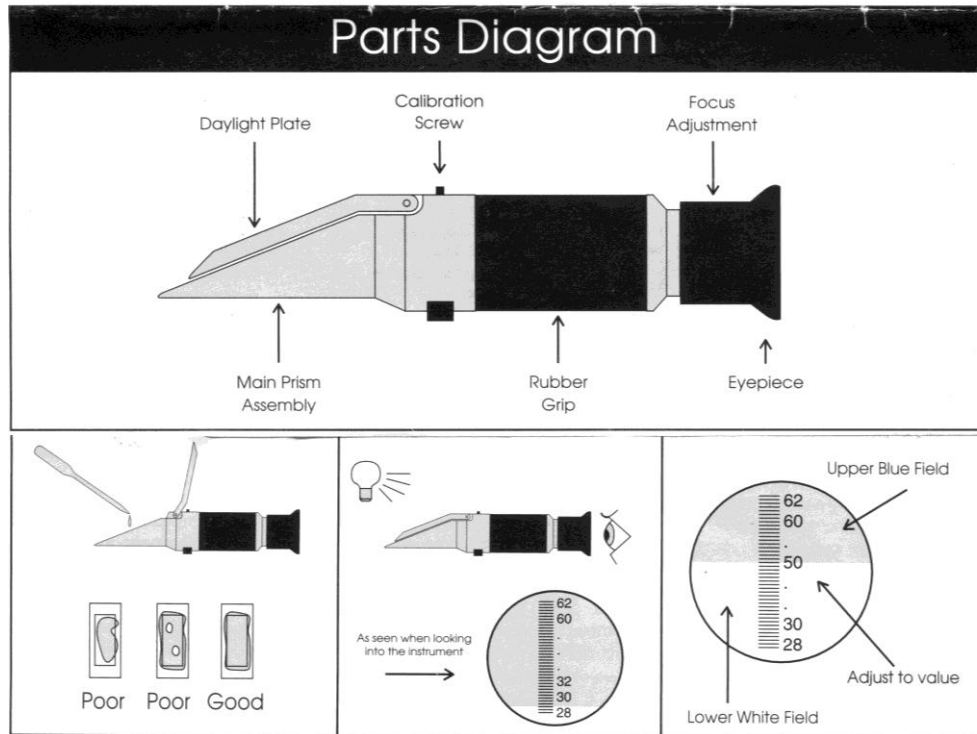

Readings are temperature sensitive, so calibrate before use:

**Calibrate the refractometer** by placing a drop of **new** Evans Waterless Coolant (High Performance, NPG+<sup>c</sup>, Heavy Duty, or Powersports) on the refractometer glass. Use the small screwdriver supplied with the instrument and set the reading to 55.7.

Always clean the glass and the daylight plate with a clean, soft cloth between readings.

Place a small amount of coolant, obtained from a location in the cooling system where the coolant is well-mixed, on the glass and close the daylight plate.

<u>°Brix</u>	<u>% water</u>
55.7	0.0
55.0	1.0
54.7	2.0
54.4	3.0
54.0	4.0
53.5	5.0
53.0	6.0
52.5	7.0