

## Installation/Service Manual

### TEST CHAMBER Model 8100-TD (6602/6603)

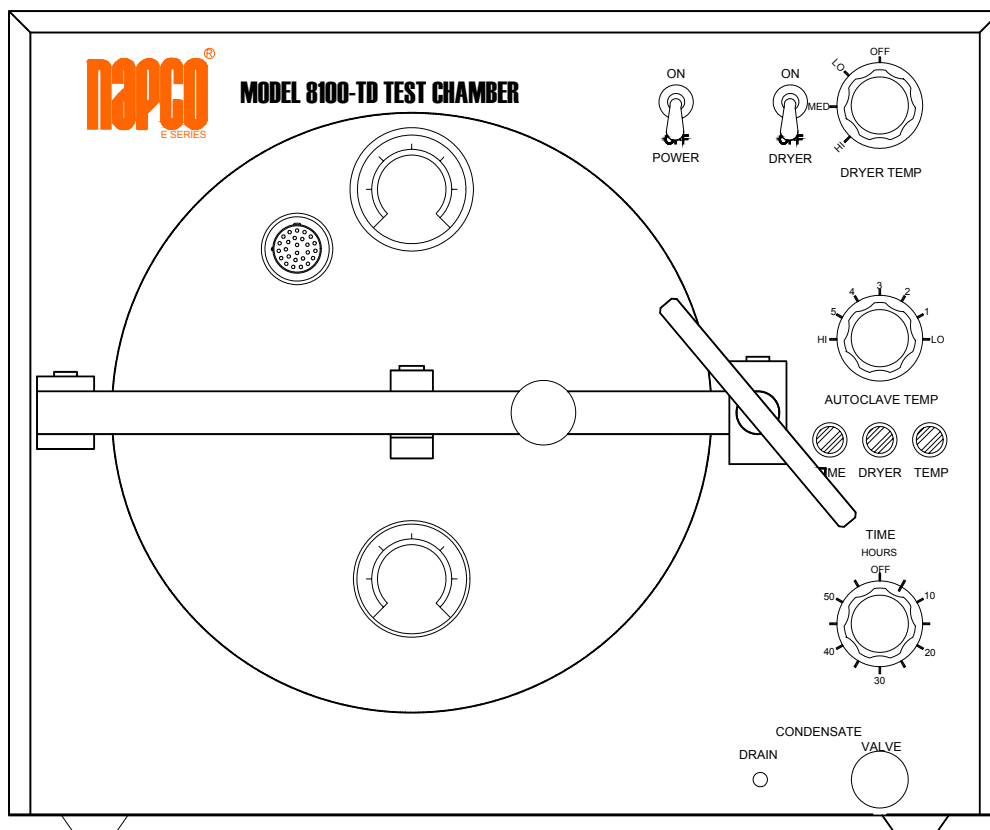

Thermo Electron Corporation  
Millcreek Road, Box 649  
Marietta, Ohio 45750  
USA  
Phone: 740-373-4763  
Toll Free: 800-848-3080  
FAX: 740-373-4189

Manual P/N 3173205  
Rev. E Dated 28APR05

## **NOTICE**

THE MATERIAL IN THIS MANUAL IS FOR INFORMATION PURPOSES ONLY. THE CONTENTS AND THE PRODUCT IT DESCRIBES ARE SUBJECT TO CHANGE WITHOUT NOTICE. THERMO ELECTRON CORPORATION MAKES NO REPRESENTATIONS OR WARRANTIES WITH RESPECT TO THIS MANUAL. IN NO EVENT SHALL THERMO BE LIABLE FOR ANY DAMAGES, DIRECT OR INCIDENTAL, ARISING OUT OF OR RELATED TO THE USE OF THIS MANUAL.

For repair information or replacement parts assistance from the manufacturer, call Technical Services using our toll free telephone number.

888-213-1790  
(FAX) 740-373-4189

## **REVISION STATUS**

INDEX	DATE	AMENDED PAGES	NOTES
A D	8/99	All	Initial release Update part no's. and combined service manual (3400745) with user manual
E	6/05	34000716	new manual #, manufacture location

# Contents

Introduction .....	1
Unpacking and Damage .....	1
Initial Procedure After Unpacking .....	2
Explanation of Controls and Their Operation .....	2
Loading The Test Chamber .....	3
Procedure for Operation of Test Chamber .....	3
Procedure for Operation of Dryer Cycle .....	4
Maintenance Suggestions .....	4
Sterilizing Cycle Data .....	5
Explanation of System Operation .....	6
Troubleshooting Procedures .....	7
Service and Testing Procedures .....	9
Assembly Drawings .....	16
Replacements Parts List .....	18
Wiring Diagram .....	20
Warranty .....	21



## INTRODUCTION

Your satisfaction and safety are important to **Thermo** and a complete understanding of this unit is necessary to attain these objectives.

As the ultimate user of this apparatus, you have the responsibility to understand its proper function and operational characteristics. This instruction manual should be thoroughly read and all operators given adequate training before attempting to place this unit in service. Awareness of the stated cautions and warnings, and compliance with recommended operating parameters — together with maintenance requirements—are important for safe and satisfactory operation. The unit should be used for its intended application; alterations or modifications will void the warranty.

### WARNING

*AS A ROUTINE LABORATORY PRECAUTION, ALWAYS WEAR SAFETY GLASSES WHEN WORKING WITH THIS APPARATUS.*

This product is not intended, nor can it be used, as a sterile or patient connected device. In addition, this apparatus is not designed for use in Class I, II, or III locations as defined by the National Electrical Code.

## UNPACKING AND DAMAGE

This product was carefully packed and thoroughly inspected before leaving our factory. Save all packing material if apparatus is received damaged.

Responsibility for safe delivery was assumed by the carrier upon acceptance of the shipment; therefore, claims for loss or damage sustained in transit must be made upon the carrier by the recipient as follows:

**Visible Loss or Damage:** Note any external evidence of loss or damage on the freight bill or express receipt, and have it signed by the carrier's agent. Failure to adequately describe such external evidence of loss or damage may result in the carrier's refusing to honor your claim. The form required to file such claim will be supplied by the carrier.

**Concealed Loss or Damage:** Concealed loss or damage is any loss or damage which does not become apparent until the merchandise has been unpacked and inspected. Should either occur, make a written request for inspection by carrier's agent within 15 days of the delivery date; then file a claim with the carrier.

If you follow the above instructions carefully, Precision will guarantee our full support of your claim to be compensated for loss or damage in transit.

DO NOT — for any reason — return this unit to **Thermo** without first obtaining return authorization. In any correspondence with **Thermo**, please supply the nameplate data, including catalog number and serial number.

## INITIAL PROCEDURE AFTER UNPACKING UNIT

### WARNING

*FOR PERSONAL SAFETY, THIS APPARATUS MUST BE PROPERLY GROUNDED.*

#### Electrical Connections

The 8100-120 Autoclave is equipped with a three-pronged (grounded) plug power cord. This mates with a three-prong receptacle to minimize the possibility of electric shock. The user should have the wall receptacle and circuit checked by a qualified electrician to make sure the receptacle is properly grounded.

Where a two-prong wall receptacle is encountered, it is the personal responsibility and obligation of the user to have it replaced with a properly grounded three-prong wall receptacle. **Do not, under any circumstances, cut or remove the third (ground) prong from the power cord. Do not use a two-prong adapter plug.**

Determine the total amount of current being used by other apparatus connected to the circuit that will be used for this apparatus. It is critical that the added current demand (see nameplate) of this and other equipment used on the same circuit does not exceed the rating of the fuse or circuit breaker.

### CAUTION

*BE SURE THAT THE POWER SUPPLY IS OF THE SAME VOLTAGE AS SPECIFIED ON THE NAMEPLATE.*

## EXPLANATION OF CONTROLS AND THEIR OPERATION

- 1) Power ON-OFF switch: Applies power to unit.
- 2) Dryer function switch: In the "ON" position, the drying function is enabled and test chamber function is disabled. In the "OFF" position, the drying functions disabled and test chamber function enabled.
- 3) Timer: Manually settable, 60 hour maximum, must be turned past 5 hours before setting desired time. (Optional 120 hour timer available.) Timer enables and controls both the test chamber and drying time. Timer in timed-out position de-energizes a solenoid valve releasing pressure from chamber (when in test chamber operation) and will also sound an alarm indicating end of cycle. Power ON-OFF switch will disable alarm.
- 4) Test chamber temperature control: Controls temperature/pressure when in test chamber operation. Low position corresponds to approximately 121°C and 15 P.S.I.. High position corresponds to approximately 132°C and 27 P.S.I..
- 5) Dryer temperature control: Controls temperature when drying function is selected. Low position corresponds to approximately 40°C.
- 6) Condensate valve and drain: Used to drain excess water from condensation tank after every test chamber cycle.

## LOADING THE TEST CHAMBER

### STEP 1

Pour water into chamber reservoir. A measuring cup is supplied. Fill until water level reaches the level indicator on the shelf.

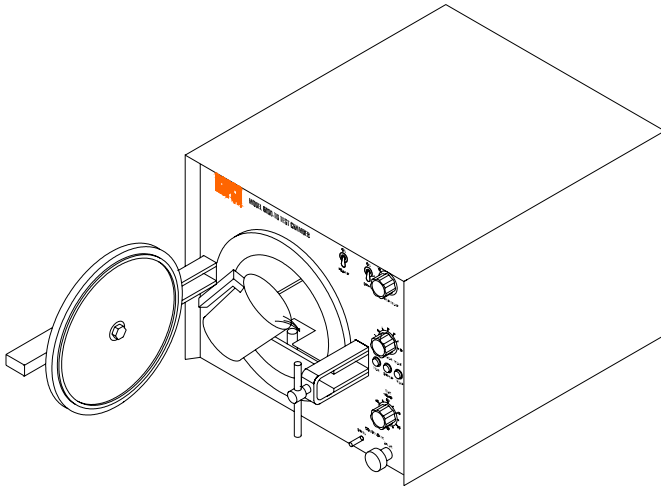

### NOTE:

*WATER LEVEL MUST REACH LEVEL INDICATOR BEFORE START OF EACH CYCLE.*

### STEP 2

Load chamber with devices to be tested. Arrange devices so water will not be trapped between them or in indentations on devices. This will help facilitate drying.

### STEP 3

After loading the test chamber, close door, replace yoke and tighten securely.

## PROCEDURE FOR OPERATION OF TEST CHAMBER

### STEP 1

Set test chamber temperature control to position 3 at the center of dial. This position will set the test chamber temperature at about 127° C.

(260°F.). When the temperature is achieved, the thermometer pointer will be positioned in the red area.

If a test chamber temperature (other than the temperature set above) is desired, the following information will be helpful for setting the test chamber temperature.

The numbers on the test chamber temperature control correspond to higher temperature settings. The point reference low on the dial face correspond to a temperature of 121°C (250°F). Numbers between the reference correspond to temperatures within the range. The range is indicated by a red area on the thermometer face. To operate the test chamber within the range, turn control knob to the high position and watch the thermometer pointer.

When the pointer indicates a desired test chamber temperature, turn the control knob clockwise until the temperature indicator light just goes out. The indicator light will then cycle on and off as the temperature is controlled at set point.

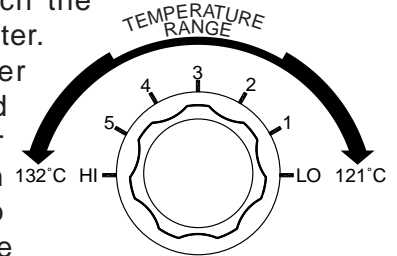

AUTOCLAVE TEMP

### STEP 2

Ensure that the power switch and dryer switch are at "OFF" position.

### STEP 3

Set the timer to desired test chamber time. Then set the power switch to the "ON" position. (The chamber will immediately begin to heat and will purge cold air from inside the chamber for approximately 10 minutes. At this time the temperature will be 95°C to 100°C. Purging will stop and chamber will rise to desired operating temperature and pressure. Temperature and pressure will be maintained until end of timed cycle.)



## **STEP 4**

At the end of set time interval an alarm will sound. The alarm will continue to sound until the power switch is set to "OFF" position. The test chamber will automatically vent and stop heating. Allow the chamber temperature to decrease to at least 100°C (212°F) before opening the door. Open the door and leave ajar.

## **STEP 5**

Before the next cycle "drain condensate". Condensate should be drained after each cycle. The chamber reservoir should be refilled to water level indicator.

## **PROCEDURE FOR OPERATION OF DRYER CYCLE**

To operate the dryer cycle: leave door slightly ajar, set the dryer switch to "ON" position, set the dryer temperature control to "LOW" position, set the timer to desired drying time interval, set the power switch to "ON" position. At the end of the set time interval, an alarm will sound. The alarm will continue to sound until the power switch is set to "OFF" position. The dryer temperature control also has a medium and high setting, select a higher temperature if desired but use caution to avoid overheating contents.

## **MAINTENANCE SUGGESTIONS**

- 1) At the end of one or two test chamber cycles: Remove screw fastener which holds shelf in place. Remove shelf to gain access to water reservoir. Add mild detergent to water and scrub reservoir and rinse chamber thoroughly with clear water. Replace shelf as above.
- 2) Oil "T" handle threads twice a year or as often as needed.

Useful information for Autoclave use other than microcircuit device testing. You may want to manually time the Autoclave cycle in the following applications, due to the short time intervals involved.

### MODEL 8100-TD STERILIZING CYCLE DATA

ITEM TO BE STERILIZED	STERILIZING TEMP. C°	STERILIZING TEMP. F°	PRESSURE	TIME REQUIRED TO STERILIZE (IN MINUTES AT AT STERILIZING TEMP)
INSTRUMENTS	121°	250°	15	20
	132°	270°	27	3 TO 6
COTTON	121°	250°	15	30
	132°	270°	27	15
RUBBER	121°	250°	15	30
	132°	270°	27	15
250cc FLASK (Thin Glass)	121°/123°	250°/254°	-	8-10
125cc FLASK (Thin Glass)	121°/123°	250°/254°	-	8-10
50cc FLASK (Thin Glass)	121°/123°	250°/254°	-	6-8
2 OZ. Comm. Bottle	121°/123°	250°/254°	-	8-10
LIQUIDS (MEDIUM)	121°/123°	250°/254°	15	15

NOTE: Sterilizing time will vary with the quantity of items in the Autoclave vessel. Use a steam clox sterilization indicator with each load.

The data shown above is based on operation of the unit at or near seal level. Because the boiling point of water varies with altitude the cycle time required for sterilization will also vary.

## **EXPLANATION OF SYSTEM OPERATION**

With the water level established, door tightened, Power Switch 'ON', Dryer switch to Dryer 'OFF', (Autoclave 'ON'), and Timer selection made, the autoclave will begin heating. Illuminated indicator lights will verify that heating and timing circuits are operational.

During the first stage of vessel heating (approx. 10 minutes from ambient) cold air will be purged from the vessel so that uniform heat is attained before pressurization of the vessel. A normally open solenoid valve allows this purging action until the steam temperature in the purge line reaches 3°C above the boiling point of water.

The Sensor (temperature-sensitive switch) located in the purge line is factory set at 103°C. The sensor switch is normally open until heated to 103°C, at which time this switch closes, energizing a latching relay. The latched relay energizes the solenoid valve, closing the purge line. The relay will remain latched until the Timer runs out or until power is removed. If there is a power interruption, the relay will unlatch, the solenoid valve will open; steam will enter the purge line, the Sensor switch will sense the steam temperature and close, the relay will latch and the solenoid valve will close. This takes approximately 6 seconds.

The autoclave Temperature Control is a pressure-sensitive switch with a sensitivity of less than 2 PSI. When the desired autoclave temperature is reached, the normally closed Temperature Control Switch will open; according to the relationship that exists between temperature and steam pressure. The element will stop heating and the temperature indication light will extinguish. The temperature and pressure will drop, the switch will close and the element will begin to heat again. This cyclic action will continue until the Timer runs out. The temperature indicating light will verify the operation of the Temperature Control Switch.

The autoclave is provided with two safety devices, a low water cut-off switch and a pressure relief valve.

The low water cut-off switch will be activated if the unit is allowed to run out of water, caused by not

filling vessel to water indicator at the beginning of each cycle or due to purge system failure in which water is boiled out of the system. The normally closed contacts, on this snap-action thermostat switch, will open when it senses and outside vessel temperature of 132°C and will close again at 110°C. It opens the circuit to the heating element. The timer will continue to operate and will shut the unit off when the set time has elapsed.

The Pressure Relief Valve is located in the condenser tank assembly. It is a safeguard against temperature control failure in which case the autoclave heating element would overheat the vessel giving a corresponding increase in pressure. The pressure relief valve will open when the vessel pressure reaches 35 PSI ± 3 PSI, venting steam into the condenser tank. If not in a position to notice the malfunction, the relief valve will vent pressure from the vessel until the water is boiled out. The low water cut-off switch will then shut off the heating circuit as previously described.

The condenser tank collects purged water and condensed steam. It should be drained after every cycle with the drain valve and drain hose fitting located on the control panel.

The 8100-TD is equipped with a drying element. NOTE: The dryer should be used with the door ajar. It is operated by turning the Power Switch 'ON', Dryer Switch to 'Dryer ON' position setting the timer and selecting the desired drying temperature in the dryer Temperature Control. The Dryer Temperature Control is an infinite control which varies the cyclic on-off rate of current being supplied to the dryer heating element and thus controlling the temperature inside the vessel. This control is variable from Low position to High position. Low corresponds to approx. 50°C, medium is approx. 90°C and high corresponds to approx. 150°C. These measurements were taken with a thermocouple mounted in a 14 pin plastic dip integrated circuit, positioned in the center of the S.S.T. Tray supplied with the unit. The door was opened 1/4" from vessel during test.

<b>Troubleshooting Procedures</b>	
<b>Problem</b>	<b>Procedure</b>
1. No Power, Temperature Light 'OFF', Timer Light 'OFF'. Unit does not heat.	<ol style="list-style-type: none"> <li>1. Check plug and electrical outlet; See Section 2.</li> <li>2. Fuse, Section 1. Also check heating element for short to ground; See Section 13.</li> <li>3. Power switch faulty; See Section 3.</li> </ol>
2. Unit does not heat, Temperature light 'ON', Timer Light 'ON'.	<ol style="list-style-type: none"> <li>1. Heating Element open; See Section 13.</li> </ol>
3. Unit does not heat, Temperature Light 'OFF', Timer Light 'ON'.	<ol style="list-style-type: none"> <li>1. Low water cut-off switch stuck open; See Section 5.</li> <li>2. Function Switch in wrong position or faulty; See Section 6.</li> <li>3. Autoclave Temperature Control stuck open; See Section 11.</li> </ol>
4. Operating Temperature and pressure cannot be achieved.	<ol style="list-style-type: none"> <li>1. Autoclave Temperature control; See Section 11.</li> <li>2. Pressure leak; See section 15.</li> </ol>
5. Temperature low, proper pressure.	<ol style="list-style-type: none"> <li>1. Sensor activating too soon; See Sections 7 &amp; 8.</li> </ol>
6. Temperature fluctuating 4°C or more on gauge, pressure fluctuation normal $\pm 1$ PSI.	<ol style="list-style-type: none"> <li>1. Water level low, not covering heating element.</li> </ol>
7. Poor or high temperature/ Pressure regulation.	<ol style="list-style-type: none"> <li>1. Autoclave Temperature control faulty; See Section 11.</li> </ol>
8. No pressure, water boils out.	<ol style="list-style-type: none"> <li>1. Sensor switch does not close or needs calibration; See Section 7.</li> <li>2. Solenoid valve stuck open or coil open; See Section 7.</li> <li>3. Possible relay problem; See Section 9.</li> </ol>
9. Audible sound of steam purging into condenser tank every 3-10 minutes, unit may run out of water.	<ol style="list-style-type: none"> <li>1. Autoclave Temperature control faulty; See Section 11.</li> </ol>

## Troubleshooting Procedures (Cont.)

Problem	Procedure
10. Excessive loss of water noticed after normal cycle.	<ol style="list-style-type: none"> <li>1. Vessel not filled to proper water level at beginning of cycle.</li> <li>2. Steam leak at door gasket.</li> <li>3. Steam leak at copper tubing connections; See Section 15.</li> <li>4. Debris on solenoid valve seat causing leak; See Section 10.</li> <li>5. Several or extended power interruptions.</li> <li>6. See Problems #7 &amp; #9.</li> <li>7. Safety pressure relief valve seat leaking; See Section 15.</li> </ol>
11. Drying element does not heat, Dryer Light 'ON', Timer Light 'ON'	<ol style="list-style-type: none"> <li>1. Dryer Element open; See Section 13.</li> </ol>
12. Drying element does not heat, Dryer Light 'OFF', Timer Light 'ON'.	<ol style="list-style-type: none"> <li>1. Function switch in wrong position or faulty; See Section 6.</li> <li>2. Dryer temperature Control faulty; See Section 14.</li> </ol>
13. Timer does not function properly	<ol style="list-style-type: none"> <li>1. Timer; See Section 1.</li> </ol>
14. Unit runs out of water or fails to shut off at excessive temperature resulting heat damage.	<ol style="list-style-type: none"> <li>1. Low Water Cut-Off Switch failure; See Section 5.</li> </ol>

## **SERVICE AND TESTING PROCEDURES**

Most tests will be performed with the cover removed from the unit. To remove cover, remove the nine screws securing the cover and lift the cover straight up and off the unit.

### **CAUTION**

*WIRING IS OPEN AND A POTENTIAL SHOCK HAZARD. UNPLUG UNIT WHENEVER POSSIBLE FOR TESTS OR REPAIRS.*

Refer to the electrical wiring diagram at all times to aid in tests. White wires are changed to blue wires on 240V units.

Terminal block (T.B.) is numbered from one at the bottom to six at the top. Facing the terminal block, T.B. Terminal R-1 would be the bottom-right terminal screw location.

Compression nuts on tubing must not be over-tightened. Tighten new compression nut one complete turn after finger tight. Retighten nut one half turn after finger tight. Tighten nut approximately one quarter turn if leaking.

#### **1.0 FUSE:** Unplug unit from electrical outlet.

1.1 Remove fuse from fuse holder and measure its resistance with an Ohmmeter. It should be less than one ohm. If fuse is open, replace with same type and amperage rating. On 100/120V units, fuse is rated 15 amps. On 240V units, fuse is rated 8 amps.

1.2 If fuse was open; See Section 13 to test heating elements as a probable cause for fuse opening circuit.

#### **2.0 POWER PLUG:** Unplug unit from electrical outlet.

2.1 With an Ohmmeter, measure the resistance from ground contact on the power plug to the units body. It should be less than one ohm. If not, check ground connection on unit and in power plug.

2.2 Plug unit in electrical outlet. Measure the AC voltage across the black and white wire at the center of the power switch. If full line voltage is not present and fuse is good; check for loose connections in the power plug.

#### **3.0 POWER SWITCH:** Unplug unit from electrical outlet.

3.1 With Power Switch in 'OFF' position, measure the resistance across the two white wires. Then measure across the two black wires on the Power Switch. Both measurements should show an infinite resistance.

3.2 Perform Step 3.1 with the Power Switch in the 'ON' position. Both measurements should be less than one ohm.

3.3 If your measurements are different than above, replace Power Switch.

#### **4.0 TIMER:** Plug unit into electrical outlet.

4.1 Turn Timer of 'OFF' position. Turn Power Switch 'ON', the buzzer should be activated. If buzzer does not activate, measure AC voltage from T.B. Terminal #2 to the black wire connection at the buzzer. If voltage is present, replace buzzer. If no voltage is present, replace Timer. Measure AC voltage across T.B. Terminals #2 and #3. No voltage should be present.

4.2 Now turn Timer to any 'ON' position. Buzzer should deactivate. Measure AC voltage across T.B. Terminals #2 and #3. Full line voltage should be present. If not, replace Timer.

4.3 If during a normal autoclave or dryer cycle the Timer does not run-out, remove power to heaters and activate the buzzer, the Timer should be replaced.

#### **5.0 LOW WATER CUTOFF SWITCH:** Designed to remove power from the heating element and solenoid valve in the event that the vessel water level gets too low. This switch is located on the underside of the vessel. See Figure 3.

5.1 To test, first ensure the vessel is below 100°C and empty of water. Connect an AC voltmeter across T.B. Terminal #2 and #3. Turn Power Switch and Timer 'ON'. Temperature and Time lights should be on. Full line voltage should be present. If not, check Timer and center wire on the Function Switch. Now move meter lead from T.B. Terminal #3 to the center wire on the Function Switch. If full line voltage is not present, replace the Low Water Cut-Off Switch.

5.3 If installing a new switch, test by repeating steps 5.1 and 5.2.

**6.0 FUNCTION SWITCH:** When this switch is in the Dryer 'ON' position, the Drying Element circuitry is enabled and autoclave circuits disabled. When in Dryer 'OFF' position, the autoclave circuitry is enabled and Dryer circuits disabled.

6.1 To test, connect an AC Voltmeter across T.B. Terminal #2 and center wire connection at the Function Switch. Turn the Timer 'ON' and turn the Power Switch 'ON'. The full line voltage should be present. If not see Sections 1 through 5.

6.2 Move meter test lead from enter wire to top wire connection on Switch. Turn Switch to Dryer 'OFF' position. Full line voltage should be present. Now turn Switch to Dryer 'ON' position, No voltage should be present. If these conditions are not met, replace Switch.

6.3 Move meter test lead from top wire to bottom wire connection on Switch. With Switch in Dryer 'ON' position, full line voltage should be present. Turn Switch to Dryer 'OFF' position; no voltage should be present. If these conditions are not present, replace switch.

**7.0 SENSOR:** (Thermal Switch, Factory set to 103°C) The sensor is a switch which activates a latching relay which in turn energizes (closes) a solenoid valve to stop the vessel from purging when the purging steam reaches 103°C.

7.1 To test, fill vessel to proper water level, tighten door, turn Function Switch to Dryer 'OFF' position, turn Timer and Power Switch 'ON'. Temperature light should be on now. Connect an AC Voltmeter across T.B. Terminal #2 and the black wire connection on the Sensor Switch. Full line voltage should be present. If not, check for loose wires at terminal block. Move meter test lead from black wire to orange wire connection on Sensor Switch. If line voltage present, replace Sensor Assembly. No voltage should be present until vessel temperature reaches 103°C. It will take approximately minutes for the vessel to reach this temperature from ambient. Observe temperature gauge on door while unit is heating. Meter should display a change from zero volts to full line voltage when temperature gauge reaches 103°C±1°C. If

Sensor does not function properly, see Section 8.0 (Sensor Adjustment) before replacing Sensor. If Sensor activates at a low temperature, turn Sensor adjusting screw 1-1/2 turns clockwise before proceeding with adjustment procedure. See Figure 2 for adjustment screw location and use and electrically insulated screwdriver if unit is plugged into electrical outlet.

**8.0 SENSOR ADJUSTMENT:** The Sensor is set at the factory (near sea level) to close the solenoid at 3°C above the boiling point of water. Since the boiling point will vary with altitude the Sensor may need adjustment when setting up the unit for operation at much higher elevations. Note the applicable temperature on the following chart.

BOILING TEMPERATURE OF WATER VS. ALTITUDE			
ALTITUDE (METERS)	TEMP. °C	ALTITUDE (FT.)	TEMP. °F
0	100	0	212
150	99.5	1000	210.1
300	98.9	2000	208.3
600	97.9	3000	206.5
900	96.9	4000	204.6
1200	95.9	5000	202.8
1500	94.8	6000	201.0
2000	92.9	7000	199.3

8.1 If vessel is hot, let cool for 10 minutes. Refill vessel to proper water level, tighten door, turn Function Switch to Dryer 'OFF' position, turn Timer and Power Switch to 'ON'. Vessel will begin to heat.

8.2 Connect an AC Voltmeter across T.B. Terminal #2 and the orange wire connection on the Sensor Switch. The meter should indicate no voltage present. Observe the Temperature Gauge while the vessel is heating. When the Temperature Gauge just reaches 3°C above the local boiling point of water, turn the Sensor adjusting screw counterclockwise until meter indicates full line voltage. An audible click of the Solenoid Valve closing also indicates line voltage is present. Now turn Power Switch 'OFF'.

8.3 Repeat Step 8.1 and 8.2 to confirm that the Sensor Adjustment is now correct. If during Step 8.2 the Sensor switched before the desired temperature, turn the Sensor Adjusting Screw 1-1/2 turns clockwise and repeat Steps 8.1 and 8.2.



8.4 If Sensor does not consistently switch at the same temperature or cannot be properly adjusted, the Sensor Assembly should be replaced. See Section 16.

**9.0 RELAY:** The Relay, once energized by the Sensor, will latch and remain latched until the / timer runs out, power turned 'OFF' or until the Function Switch is turned to Dryer 'ON' position. When the relay is latched, it supplies power to energize and close the Solenoid Valve.

9.1 If vessel is hot, let cool for 10 minutes then refill vessel to proper water level, turn Function Switch to Dryer 'OFF' position, turn Timer and Power Switch 'ON'. Connect an AC Voltmeter across T.B. Terminal #2 and the orange wire connection on the Sensor Switch. No voltage should be present. If voltage is present, replace Sensor Assembly.

9.2 Now move meter test lead from orange wire to T.B. Terminal #6. If voltage is present, replace relay. Momentarily touch an insulated jumper wire across the two wire connections on the Sensor. The relay should latch and the meter should indicate full line voltage, If voltage is not present and/or relay will not remain latched with jumper wire removed, replace relay. If relay vibrates or clatters, it should be replaced.

**10.0 SOLENOID VALVE:** The Solenoid Valve, when energized, closed and allows vessel to pressureize. See Figure 2.

10.1 Unplug unit from electrical outlet. Disconnect the Solenoid wire from T.B. Terminal #R6. Temporarily connect this wire to T.B. Terminal #3. Plug unit into electrical outlet. Turn Power Switch 'ON'. Now turn Timer 'ON' and 'OFF' several times. When the Timer is turned 'ON' you should hear a single audible click which indicates actuation of the valve and continuity of the solenoid coil. If you cannot hear the Solenoid Valve actuate or if it clatters when energized, it should be replaced. Unplug the unit and return the Solenoid wire from T.B. Terminal #3 to T.B. Terminal #R6.

10.2 Now test Solenoid Valve under operation. If vessel is hot, let cool for 10 minutes. Refill vessel to proper water level, turn Function Switch to Dryer 'OFF' position, turn Timer and Power Switch 'ON' and rotate Autoclave Temperature Control to highest setting. Connect an AC Voltmeter across T.B. Terminal #2 and T.B. Terminal #6. No voltage should be present until Sensor senses 103°C steam from vessel. If voltage is present, see Sections 7 and 9 for Sensor and Relay problems.

10.3 When the vessel reaches 103°C, the relay will be latched and power applied to the Solenoid Valve. This will be indicated on the Voltmeter. The purging of excess water and steam into the Condenser Tank should stop completely. Pressure should begin to build up in the vessel as indicated on the Pressure Gauge.

10.4 If Solenoid Valve is clattering, it should be replaced. Observe condenser coil in Condenser Tank for water or steam escaping, which would indicate a leaking or open Solenoid Valve. See Figure 4. At this time, also observe the Safety Pressure Relief Valve for any leaks. Replace if leaking.

10.5 If Solenoid Valve appears to be leaking, turn unit off and allow it to cool. Before replacing Solenoid Valve, attempt to clean the Valve Seat. Remove the 3/4" Hex Head Plug from the Solenoid Valve body. Inspect and clean debris from the spring loaded metal encased rubber plunger and the metal valve body seat. Reassemble and retest as in Section 10.2. If Solenoid Valve still fails to function properly, it should be replaced.

**11.0 AUTOCLAVE TEMPERATURE CONTROL:** This control is a pressure actuated switch which opens the circuit to the autoclave heating element when set pressure has been reached.



11.1 To test, let vessel cool for 10 minutes if hot. Refill vessel to proper water level, turn Function Switch to Dryer 'OFF' position, turn Timer and Power Switch 'ON' and rotate Autoclave Temperature Control to highest setting. If the Temperature Pilot Light is 'OFF' connect an AC Voltmeter across T.B. Terminal #2 and T.B. Terminal #4. Full line voltage should be present. If not, see Sections #3, #4, #5 and #6. Now move meter test lead from T.B. Terminal #4 to T.B. Terminal #5. Full line voltage should be present while vessel is in its' initial heating stage before pressurization. If line voltage is not present at T.B. Terminal #5, replace Autoclave Temperature Control. See Section 17. If this is a new control, ensure one wire is connected to 'Common' and the other wire connected to the 'N.C.' (normally closed) contact on the controller.

11.2 Allow vessel to continue heating until maximum temperature and pressure are reached, If pressure goes above 30 PSI or controls at less than 27 PSI at maximum setting, go to Section 12 to attempt adjustment. If controlled pressure fluctuates more than 2 PSI from set point after one hour, replace Autoclave Temperature Control. See Section 17.

## **12.0 AUTOCLAVE TEMPERATURE CONTROL ADJUSTMENT:**

12.1 While vessel is under pressure in autoclave cycle, loosen the two set screws in the control knob and remove knob. Set the control knob shaft so that the Autoclave Temperature Control regulates at 27 PSI  $\pm$  1 PSI/133°C $\pm$ 1°C. If pressure/temperature is high, turn shaft clockwise. Allow controller ample time to reach set point after making an adjustment. If pressure varies over 2 PSI or fluctuates inconsistently, the control should be replaced. See Section 17.

12.2 Once the control is properly adjusted at 27 PSI  $\pm$  1 PSI, place control knob on shaft. Turn knob counterclockwise until knob reaches stop. Now tighten knob to control shaft.

12.3 Turn Control Knob fully clockwise. allow ample time for vessel to cool and be controlled at low set point. Pressure should drop to at least 15 PSI and control  $\pm$ 1 PSI. If Controller will not do this, it should be replaced.

**13.0 HEATING ELEMENTS:** Autoclave and Dryer Elements. Unplug unit from electrical outlet.

13.1 To test Dryer Element (Top Element), remove both wires from the Dryer Element terminals on top of the vessel. Connect an Ohmmeter across the two element terminals. The Dryer Element should measure 11.5 ohms  $\pm$  0.6 ohms on 120V Elements or 46 ohms  $\pm$  3 ohms on 240V Elements, if not, replace Element. See Section 18. Now conduct test in Section 13.3.

13.2 To test Autoclave Heating Element (bottom Element), remove bottom access cover and remove both wires from the Heating Element terminals. Connect an Ohmmeter across the two Element terminals. The autoclave element should measure 10.3 ohms  $\pm$  .6 ohms on 120V Elements or 41 ohms  $\pm$  3 ohms on 240V Elements. If not, replace Element. See Section 18. Now conduct test in Section 13.3.

13.3 Now select highest resistance range on Ohmmeter. Touch one test lead to either terminal on Element on touch other test lead to the vessel body. This test will give an indication whether or not the Element is shorting to ground. Do not touch ends of test leads with hands. If you get any meter indication less than infinity, replace Heating Element. See Section 18. Replace wires to Element when test is completed.

**14.0 DRYER TEMPERATURE CONTROL:** This is an infinite control which varies the 'ON-OFF' rate and current 'ON' time which is being supplied to the Dryer Heating Element. The rate/time interval is a function of the Dryer Control Setting.

14.1 The Dryer Temperature Control has 5 wire connections labeled; **P**, **L-1**, **L-2**, **H-1** and **H-2**. Connections **L-1** and **L-2** are the power input point. Connections **H-1** and **H-2** are the power output points which lead to the Dryer Element. Connection **P** supplies power to the Dryer Pilot Light when the Dryer Temperature Control is turned ON.

14.2 To test Dryer Temperature Control first test Dryer Heating Element as in Section 13. Now turn Timer, Power Switch and Function Switch 'ON'. Connect an AC Voltmeter across the two Dryer Temperature Control contacts labeled '**L-1**' and '**L-2**' to ensure power is present at Controller inputs. If line voltage is not present, see Sections 3, 4, 5 and 6.

14.3 Now connect the AC Voltmeter across the two Dryer Element terminals. With Dryer Temperature Control 'OFF', no voltage should be present and the Dryer Pilot Light should be out. If voltage is present, replace Dryer Temperature Control. Turn Dryer Temperature Control to 'LOW' position and observe Voltmeter. Line voltage should be present for less than 5 seconds approximately once every 25 seconds. Turn Dryer Temperature Control to 'HIGH' position and observe Voltmeter. Line voltage should be present for less than 5 seconds approximately once every 16 seconds. If the above conditions are not met, replace Dryer Temperature Control.

**15.0 CHECKING FOR SYSTEM LEAKS:** Unplug unit from electrical outlet. Move insulation away from the copper tubing connections at the vessel and Sensor so they may be observed during test.

15.1 Plug unit into electrical outlet. Fill vessel to proper water level, tighten door, turn Timer and Power Switch 'ON', turn Function Switch to Dryer 'OFF' and turn Autoclave Temperature Control fully counter clockwise. Allow unit to reach maximum temperature and pressure.

15.2 Observe around door gasket, all fittings and the Pressure Relief Valve for leaks. Also see Sections 10.3 through 10.5.

15.3 If a door gasket leak cannot be stopped by tightening door, it should be replaced. Replace leaking Pressure Relief Valve. If fittings are leaking, unplug unit from electrical outlet and allow unit to cool.

15.4 Tighten the leaking fitting up to 1/4 turn. DO NOT tighten excessively, see Introductory Information at beginning of Test Procedures. DO NOT twist tubing when tightening. Use a second tool to hold part from turning.

15.5 After repairing a leak, always retest unit in Autoclave Cycle. If a repaired fitting leaks after re-testing, it should be replaced. Order the preformed copper tube sections with new compression nuts, as necessary.

**16.0 SENSOR ASSEMBLY REPLACEMENT:** Unplug unit from electrical outlet.

16.1 Remove the two wires from the Sensor Switch.

16.2 Completely loosen the tube compression fitting on top of the Sensor Body.

16.3 With the bottom access cover removed, completely loosen the tube compression fitting from the vessel and then remove the Sensor Assembly.

16.4 Place new Sensor Assembly in position. Install new compression nut over Sensor Tube and then inset tube into vessel fitting. Tube may have to be bent slightly or vessel fitting turned to get proper position. Tighten one complete turn after finger tight. If retightening, turn nut 1/2 turn after finger tight.

16.5 Retighten tube fitting from Solenoid Valve to top of Sensor Body. Tighten 1/2 turn after finger tight.

16.6 Replace black wire to 'COM' connection on Sensor Switch. Replace orange wire to 'N.O.'

16.7 Test and adjust Sensor as per Section 8. also check for leaks.

**17.0 AUTOCLAVE TEMPERATURE CONTROL REPLACEMENT:** Unplug unit from electrical outlet.

17.1 Remove black wires from T.B. Terminals #4 & #5, which lead to the controller.

17.2 Completely loosen the two compression nuts on the back of the Control. DO NOT bend tubing more than necessary to clear Controller.

17.3 Loosen the two set screws on the control knob and remove the knob.

17.4 Remove the nut from the Control knob stop and then remove the Autoclave Temperature Control.

17.5 Install new Control in Control Panel and replace nut on Control knob stop.

17.6 Retighten the two tube compression nuts to the back of the Controller.

17.7 Connect the bottom black control wire to T.B. Terminal #4. Connect the top black wire to T.B. Terminal #5.

17.8 Do not replace knob until adjusted properly. Plug unit into electrical outlet. Fill vessel to proper water level, tighten door and start Autoclave Cycle. Now proceed with Autoclave Temperature Control Adjustment per Section 12. Also check for fitting leaks while unit is under pressure.

**18.0 AUTOCLAVE AND DRYER ELEMENT REPLACEMENT:** For the Autoclave Element you must remove the bottom access cover, shelf screw and shelf.

18.1 Remove the nut, lockwasher and wire from each Element terminal.

18.2 Remove the two large nuts and lockwashers which secure the Element to the vessel.

## MAINTENANCE

**19.0 CLEANING:** Stainless steel will resist corrosion; however, it is not impervious to it. Proper maintenance of the stainless steel bath chamber will help assure many years of service. It should be cleaned regularly with mild soapy water and rinsed with distilled water. Should algae or other undesirable microorganisms form on the top of the bath media, add a little formaldehyde or zephiran chloride to alleviate this problem.

### CAUTION

*AVOID SPILLING HARSH CHEMICALS ONTO THE BATH AS CORROSION OF THE STAINLESS STEEL MAY RESULT.*

### IMPORTANT

*IF IT IS NECESSARY TO USE THE FOLLOWING CHEMICALS, LIMIT THE TIME TO A MAXIMUM OF FOUR HOURS. CLEAN SURFACES IMMEDIATELY AFTER USE.*

-Aluminum Chloride	-Barium Chloride
-Bichloride of Mercury	-Calcium Chloride
-Carbolic Acid	-Chlorinated Lime
-Citric Acid (boiling)	-Dakin's Solution
-Ferrous Chloride	-Mercury Salts
-LysolMercuric Chloride	-Phenol
-Potassium Permanganate	-Stannous Chloride
-Sodium Hypochlorite	-Tartaric Acid
-Potassium Thiocyanate	

### CAUTION

*NEVER USE THE FOLLOWING CHEMICALS.*

-Aqua Regia	-Ferric Chloride
-Iodine	-Sodium Azide
-Sulfuric Acid	

19.1 Removing Discoloration: Should the stainless steel ever become discolored by iron rust, use the following procedure to remove all traces of the rust and restore the stainless steel.

### WARNING

*OBSERVE THE FOLLOWING SAFETY PRECAUTIONS! USE HEAVY GLOVES OR OTHER ADEQUATE EYE PROTECTION. ONLY WORK IN AREAS WITH ADEQUATE VENTILATION.*

Prepare a solution of 20% nitric and 1.5% hydrochloric acid (if preferred, a 2% to 5% solution of warm oxalic acid may be used). Swab solution over surface, allowing it to remain until all rust is loosened. This will usually take 1 to 2 minutes.

As soon as rust is loosened, immediately flush with clean water until all acid is removed. Dry thoroughly.



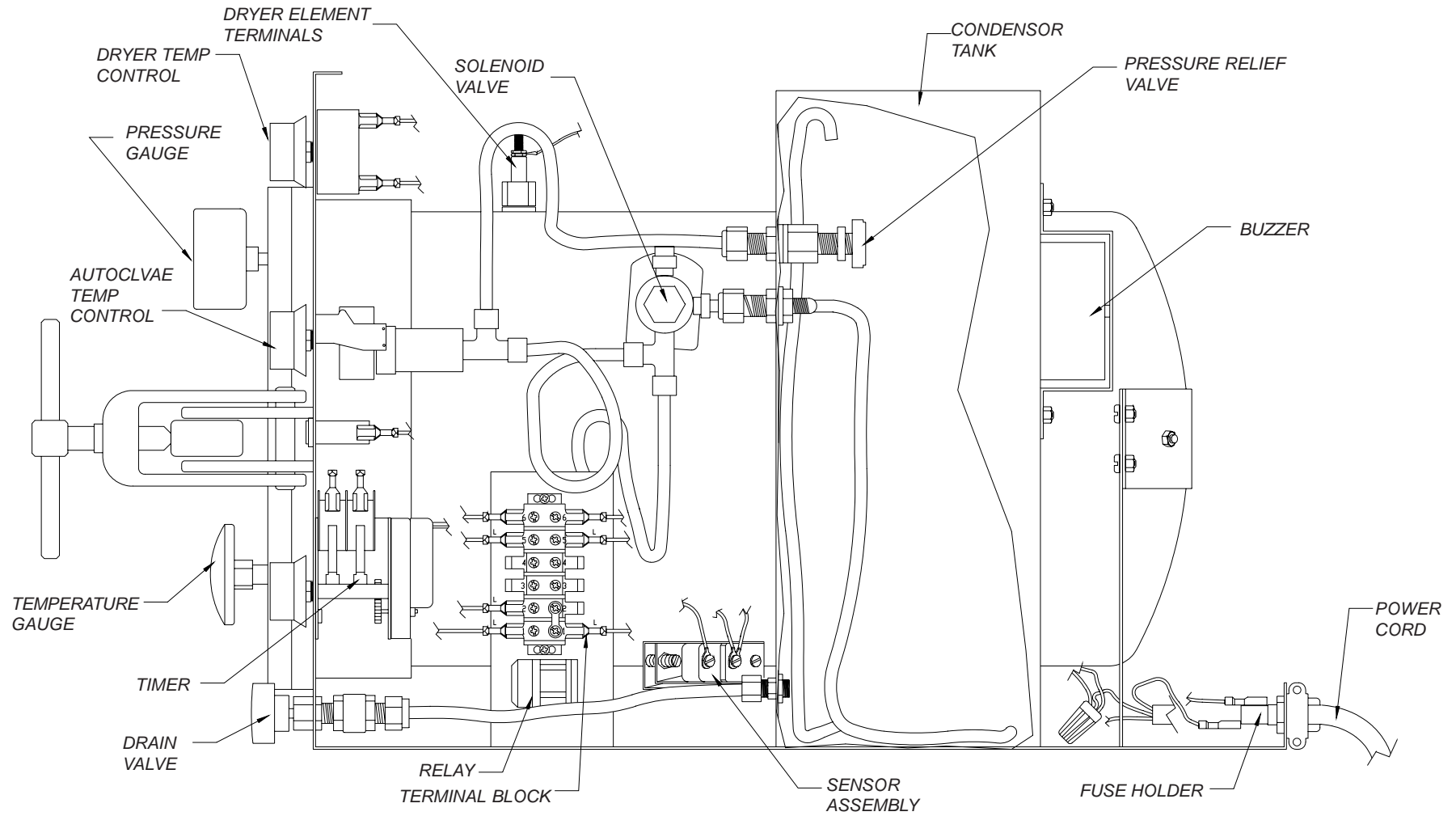

<b>REPLACEMENTS PARTS LIST</b>		
<b>PART DESCRIPTION</b>	<b>8100-120</b>	<b>8100-220</b>
Power Switch	3175313	
Dryer Switch	3175310	
Dryer Temperature Control Kit	3161743	3161744
Temperature Assembly Control Kit	3166983	
Temperature Gauge	3176000	
Pressure Gauge	3175612	
Timer	3173414 (60 hr.) 3173093 (120 hr)*	3173417
Temperature Sensor Assembly	3166951	
Heating Element Kit	3167030	3161157
Drying Element Kit	3166948	3166949
Dryer Thermal Cutoff	3175265	
Heater Thermal Cutoff	3175259	
Solenoid Assembly	3166966	3161291
Power Cord	3173327	3173329
Knob, Temperature and Timer	3174898	
Relay	3173391	3173392
Socket	3173397	
Alarm Buzzer	400052	3176034
Fuse Kit	3167231	3167228
Door	3173249	
Door Gasket	3166981	
* 3173093 is replacement timer for catalog number 3166407		

<b>REPLACEMENTS PARTS LIST(Cont.)</b>		
<b>PART DESCRIPTION</b>	<b>8100-120</b>	<b>8100-220</b>
Door Clevis/ Yoke Kit (w/ T-Handle)		3167035
Door Bar Assembly Kit		3161035
Condenser Tank Gasket		3175090
Water Baffle Kit		3166933
Condenser Tank Weldment		316101
Pressure Relief Valve		3175880
Drain Valve Assembly		3177559
Tube, Temp. Sensor to Vessel		3161782
Tube, Sensor to Solenoid		3161783
Tube, Condenser Coil		3167092
Instrument Tray		316103
Shelf		316104
Hinge Support		3174126
Hinge		3177580
Wire Harness		3174039
Test Lead Connector Assembly		3167227



WIRING DIAGRAM

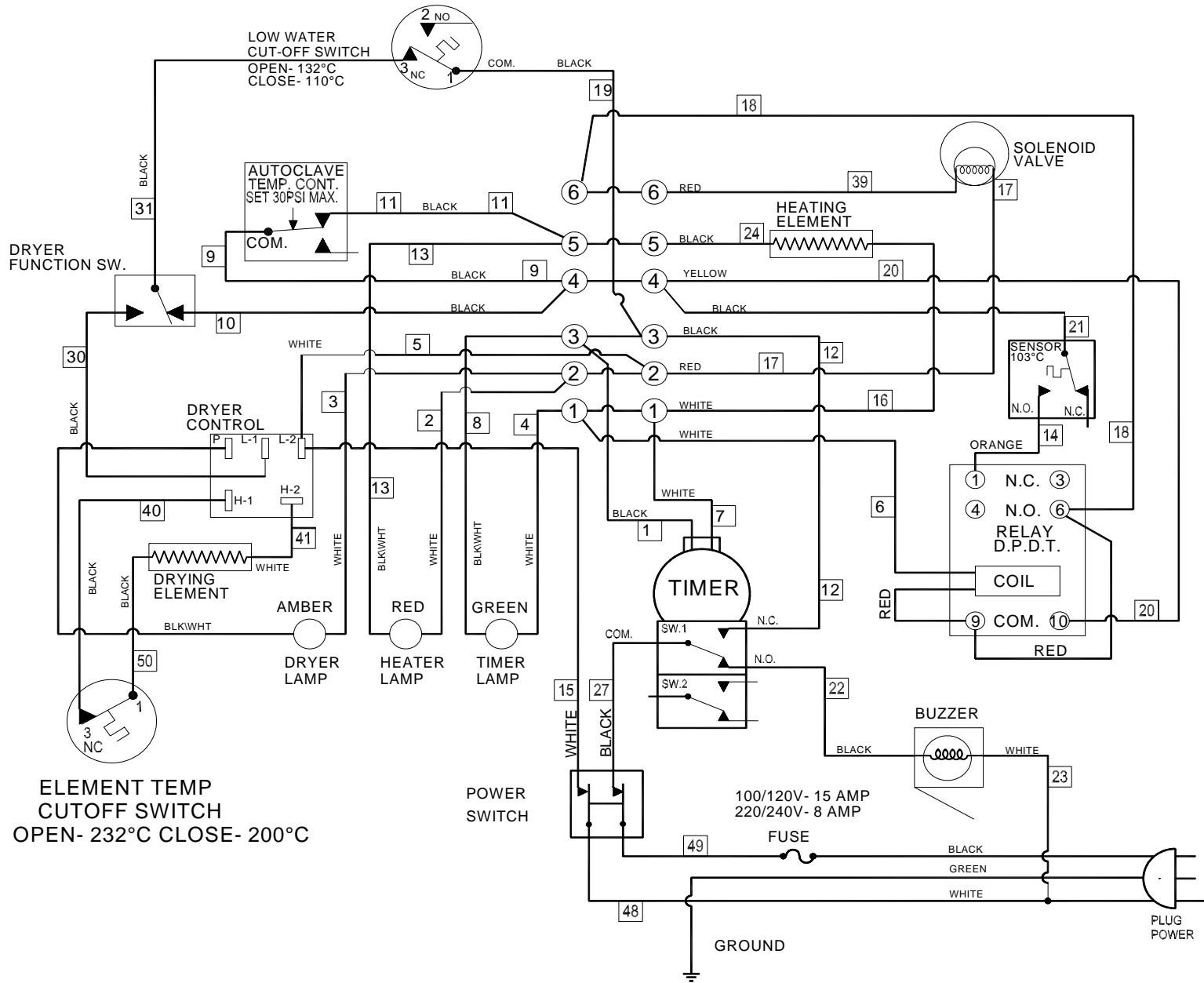

ELEMENT TEMP  
CUTOFF SWITCH  
OPEN- 232°C CLOSE- 200°C

NOTE: WIRING SHOWN IS FOR 100/120V UNIT.  
FOR 220/240V UNIT, ALL WHITE WIRES BECOME BLUE

## **THERMO ELECTRON CORPORATION STANDARD PRODUCT WARRANTY**

The Warranty Period starts two weeks from the date your equipment is shipped from our facility. This allows for shipping time so the warranty will go into effect at approximately the same time your equipment is delivered. The warranty protection extends to any subsequent owner during the first year warranty period.

During the first year, component parts proven to be non-conforming in materials or workmanship will be repaired or replaced at Thermo's expense, labor included. Installation and calibration are not covered by this warranty agreement. The Technical Services Department must be contacted for warranty determination and direction prior to performance of any repairs. Expendable items, glass, filters and gaskets are excluded from this warranty.

Replacement or repair of components parts or equipment under this warranty shall not extend the warranty to either the equipment or to the component part beyond the original warranty period. The Technical Services Department must give prior approval for return of any components or equipment. At Thermo's option, all non-conforming parts must be returned to Thermo Electron Corporation postage paid and replacement parts are shipped FOB destination.

**THIS WARRANTY IS EXCLUSIVE AND IN LIEU OF ALL OTHER WARRANTIES, WHETHER WRITTEN, ORAL OR IMPLIED. NO WARRANTIES OF MERCHANTABILITY OR FITNESS FOR A PARTICULAR PURPOSE SHALL APPLY.**

Thermo shall not be liable for any indirect or consequential damages including, without limitation, damages relating to lost profits or loss of products.

Your local Thermo Sales Office is ready to help with comprehensive site preparation information before your equipment arrives. Printed instruction manuals carefully detail equipment installation, operation and preventive maintenance.

If equipment service is required, please call your Technical Services Office at 1-888-213-1790 (USA and Canada) or 1-740-373-4763. We're ready to answer your questions on equipment warranty, operation, maintenance, service and special application. Outside the USA, contact your local distributor for warranty information.



