

INSTRUCTION MANUAL FOR
KOBO TC-851
HOT STAMPING MACHINE



**ADA-compliant Polymers
for Environmental Graphics**



TABLE OF CONTENTS

	Page #
CAUTIONS	1
INSTRUCTIONS.....	1
PARTS OF TC-851.....	2-4
ATTACHMENTS 7 INSTALLATION.....	5
Unpack the Wood Case	5
Attachments.....	5
Installing the TC-851.....	5
PREPARATIONS	
Preparation of Artwork Drawings.....	6
Preparation of Graphic Films.....	6-7
Preparation of Engraving Plate/Die.....	7-8
Foil Selection.....	8
Jigs and Fixtures.....	9
SETTING UP	
Setting of Foil.....	9-10
Setting of Foil Feed Timer	10
Setting of Temperature.....	11
Adjustment of Stamping Stroke.....	11-12
Set Engraving.....	12-14
Installation of Type/Engraving Holder.....	14
Type/Engraving Holder Leveling.....	14
OPERATION PROCESS.....	15
TROUBLESHOOTING.....	15-16
HINTS FOR ENGRAVING PRINTING.....	16
DISLOCATION OF FOIL ADVANCING.....	16-17
TYPE/ENGRAVING HOLDER EXCHANGE.....	17
MAINTENANCE.....	18
Cleaning.....	18
Lubrication.....	18
SPECIFICATIONS.....	19
CIRCUIT DIAGRA.....	20-21

CAUTION

First, operation of the new machine is likely to cause smoke-like fumes, which is normal and harmless. Whenever the machine is switched on, never try to touch the heating parts with bare hands as this may cause burns.

INTRODUCTION

Welcome to KOBO printers' family and your selection of the TC-851 Hot Stamping Machine.

The TC-851 is the most modern and technically-advanced machine in its class. This machine can generate a working pressure up to 2,500 Kg. and provides an instant and convenient way of Hot Foil Printing and Embossing. It can be used to imprint business cards, greeting cards, fancy goods and promotional products (plastic, paper, wood, leather and cloth) and for over-printing including packaging.

For proper operation and getting the best performance, please read the instruction manual thoroughly before you run the machine.

PARTS OF THE TC-851

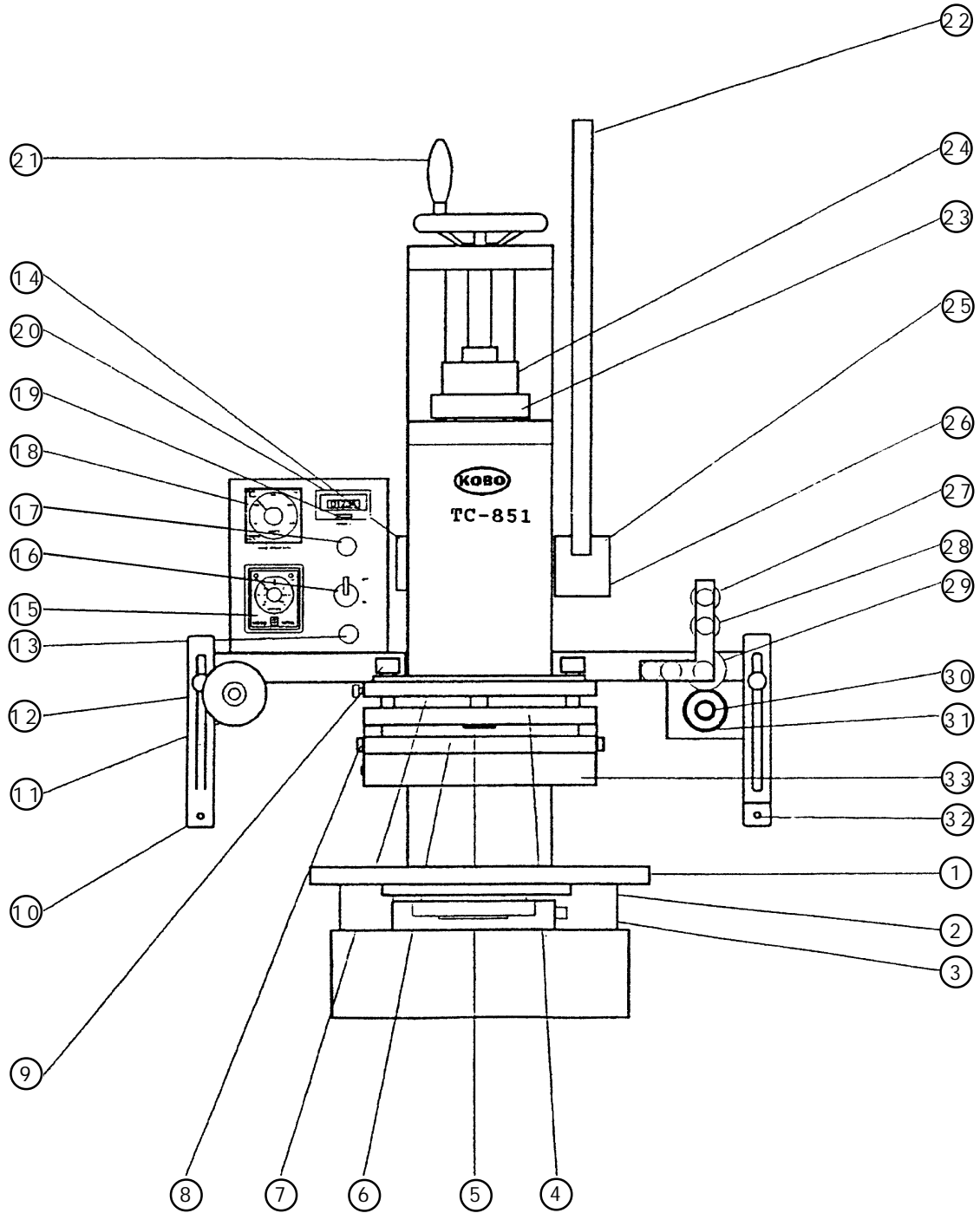

PARTS OF THE TC-851

No.	Name of Part	Function
1	Sliding Feed Table	A table on the machine for mounting the fixture and put on the printing subject, slides manually to facilitate the printing process.
2	Handle	For sliding the sliding feed table.
3	Fastening Screw	Adjusts the sliding feed table to your requirement.
4	Balancing Plate	For balancing and leveling the type/engraving holder to the required level and achieve the best performance.
5	Pivot Screw	Serve as a pivot for the balancing plate (4) which is leveled by adjusting four leveling screws (9) on fixed plate (7).
6	Heating Block	Holds the heater inside to generate heat required for hot foil printing and embossing.
7	Fixed Plate	Attaching the balancing plate, heating block and type/engraving holder to the sliding block.
8	Fixing Screws	Tightens or loosens the type/engraving holder.
9	Leveling Screws	Used to balance and adjust the level of the balancing plate (4).
10	Left Foil Guide Bar	Guides the foil to the desired level.
11	Foil Holder	Holds the roll of foil.
12	Fixing Ring	Adjusts the position of the foil holder
13	Fuse	
14	Grease Nozzle	Greases the rotating shaft of the operating handle.
15	Foil Feed Timer	Sets the length of foil feed.
16	Main Switch	Power on/off switch.
17	Power Indicating	Lighted when power is "on".
18	Thermo Controller	Adjusts temperature of the heating block (6) to suit printing requirements.
19	Reset Button	Resets the counter to zero.
20	Counter	Indicates the number of runs achieved.
21	Hand Wheel	Adjusts the shut height between type/engraving holder (33) and sliding feed table (1).
22	Operating Handle	When pulled down, applies pressure to the type/engraving and the printing subject to accomplish the printing process,
23	Adjusting Nut	Adjusts stroke of the type/engraving holder
24	Fixing Nut	Fixes position of the adjusting nut (23) after the stroke has been adjusted.
25	Handle Holder	Holding the operating handle (22).
26	Fixing Screw	Fixes the operating handle (22) to the handle holder (25).
27	Used Foil Collector	Collects the used foil.
28	Transmission Roller	Transmits the rolling movement of nylon roller (31) to the used foil collector (27).
29	Metal Roller	Works in conjunction with nylon roller (31) to facilitate foil feeding.
30	Foil Feed Knob	Advances foil manually and adjusts tension of foil.
31	Nylon Roller	Provides constant transmission for foil feeding.
32	Right Foil Guide Bar	Guides the foil to the desired level.
33	Type Holder or Engraver Holder	Holds the type setting, or holds the stamping plates

ATTACHEMENTS & INSTALLATION

Unpack the Wood Case

The machine is packed in a strong wood case to protect the machine from damage during transportation. Care must be taken when you are dismantling the wood case to prevent damaging the machine.

Do not apply force directly on the Foil Feeding System and the electronic Control Box when lifting the machine to the working table,

Attachments

The following are standard accessories and tools provided and packed with the machine:

1	Operating handle	1 piece
2	Holder handle	2 pieces
3	Wrenches	2 pieces
4	Screwdrivers	2 pieces
5	Allen keys	6 pieces
6	Operation Manual	1 set

Installing the TC-851

Installation of the TC-851 is very simple. You need only to insert the Operating Handle into the handle Holder and tighten the Fixing Screw (26) provided. Insert the power plug into the correct power socket and the machine is ready to start.

** MAKE SURE your power supply voltage complies with the INPUT requirement labeled on the machine. Use a transformer to step up or down the power supply to the voltage required if necessary.

PREPARATION

Before hot stamping, you need to make some preparations including artwork, graphic files, engraving plate or types, choice of foil, jigs and fixtures, etc. This chapter briefly explains how this can be done to obtain perfect printing results.

Preparation of Artwork

Camera-ready artwork is the first thing you need to prepare for Hot Stamping.

Your camera-ready artwork can be created using a personal computer with the proper desktop publishing of illustration software and a high-quality laser printout, or...

you can create artwork with a typewriter, dry transfer lettering, lettering machines phototypesetter, handwriting, drawings, or...

have the artwork supplied by your customer. For best results, artwork should be prepared in dense black, free of flashes or burrs.

For camera processing, artwork/lettering should be drawn on or pasted to a piece of thick drawing paper. The paper must be sufficiently thick so it does not easily bend. The paper's surface should not reflect light during photographing.

To make a negative on the KOBO Photopolymer Platemaker, you can prepare your dense artwork/lettering on clear transparency paper or sheet. If you have artwork on white paper or board, you can photocopy it onto transparency paper. You can also increase or reduce the size of artwork on a photocopier if it has this feature.

Preparation of Graphic Films

You can produce a negative on a process camera if you have one, or...

Have the negative made by your local graphic design shop or professional film processor, or...

You can make a negative on our KOBOL Photopolymer Plate.

The density of the negative must be high for best results. The non-transparent black portion must be dark so light will not pass through it. You should use MATT negative when using sheet photopolymer plates. The reading side should be matt.

Preparation of Engraving Plate/Die

The three most common types of hot stamping dies are:

1. Metal Die/Plate: Metal dies/plates can be made of zinc/magnesium, copper or brass. Metal dies/plates are commonly adopted by most press printers but they require some craftsmanship in carving or etching.

The use of metal dies is recommended for long runs, or for frequently recurring jobs, and for printing promotion products. Softer zinc/magnesium dies are the most commonly used dies. Their running life varies and depends on the pressure to be exerted and temperature required for printing. Thin dies are not recommended for thicker material or more rugged surfaces.

Copper dies are suitable for longer runs on plastics and leathers. Brass dies last longest and are very expensive as they cannot be chemically etched like other dies, so they are seldom used.

2. Rubber / Silicone Dies: These dies are good for hot stamping on rigid or brittle plastic materials with undulating surfaces.
3. Photopolymer Dies: Photopolymer is a newly developed material for engraving plates. A metal backing plate is coated with a layer of photosensitive plastic material. The plastic layer is polymerized after exposure to UV-light and becomes hardened. When a negative is laid on the surface of a photopolymer plate during exposure, the area under the image portion is hardened while other areas remain soft. After water washout, the soft areas are washed and the engraving is made.

Foil Selection

Correct selection of foil is an important factor for perfect Hot Stamping. There are three major points to consider:

1. Compatibility
The foil used must be compatible with the material to be printed. Ask for the specifications for different types of foil offered by your local foil supplier.
2. Color
Ask for a foil reference chart from your local foil supplier and select the correct color for your job.
3. Cut Width
The width of the foil should be enough to cover the image area to be imprinted. Always allow at least 1/4" on each side. Check to be sure your machine can accept the width.

Jigs and Fixtures

Before printing starts, you need to prepare a jig or a fixture to hold the printing object in the correct position. Take the following into consideration:

1. Accuracy: The jig or fixture should hold the object to be printed securely to allow imprinting in the exact location, repeatedly.
2. Efficiency: A jig or fixture should allow quick and easy positioning of the object to be printed.
3. Safety: The jig or fixture should not have any sharp points or edges that may harm the operator or material to be printed.

SETTING UP

Setting of Foil

1. Choose a foil compatible with the material to be printed. The foil width should be sufficient to cover the image area with minimum waste.
2. Loosen the screw on the FIXING RING, pull out the FIXING RING and the PLASTIC STOPPER from the FOIL HOLDER at the left side of the machine.
3. Load the roll of foil on the foil holder, put back the PLASTIC STOPPER and the FIXING RING, tighten the FIXING RING to guide the foil with optimum position.
4. Load the foil with the emulsion side down through the two GUIDE BARS at two sides of the block and upward through the NYLON ROLLER and METAL ROLLER by advancing the FOIL FEED KNOB.
5. Place the leading end of the foil on to the used FOIL COLLECTOR and fix in place with the FOIL CLIP.
6. Rotate clockwise the FOIL FEED KNOB to advance the foil and maintain a constant tension of foil.
7. Adjust the two FOIL GUIDE BARS for optimum level and foil. Distance between the foil and material to be printed should be approximately 10mm. Make sure the level of foil will not cross the printing object while operating.
8. Always maintain the foil set between left and right foil guide bars in a constant tension mode by rotating the FOIL FEED KNOB and/or by adjusting the fixing ring.

Setting of Foil Feed Timer

The length of foil feed for each run is set by adjusting the time factor on the length of the Foil Feed Timer. Markings on the timer are in seconds and represent the running time of the foil winding motor. The longer the time, the more length of foil feed used for each run. If the foil feed timer is set to zero, the automatic feeding system will not function.

It lights when foil feed starts and when foil feed ends.



Foil Feed Timer

Indicator Light.

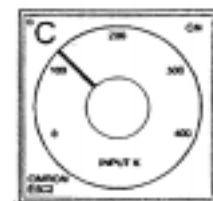

Thermo Controller.

Temperature Setting

Printing temperature is controlled by a safe and reliable thermostat. When the Heating Block reaches the required temperature, the Heater automatically shuts off and the Heater Indicator also shuts off. The Heater Indicator turns on and off during operation, maintaining the required temperature.

Before printing, turn the Temperature Controller to a higher temperature. The Heating Block needs about 15 minutes to warm up at room temperature. After the Heater Indicator turns off, adjust the Temperature Controller to the appropriate setting.

The material to be printed and type of die/plate used determine the machine temperature requirements more than the color of foil used. Ask your local foil supplier about optimum temperature for the foil you use. Their input can be useful.

Temperature requirements for most material falls between 100° C to 200° C. A guidance table is detailed below for your reference.

IMPRINT MATERIAL	APPLIED TEMP C
Leather / PVC	110 – 150
Paper	100 – 140
Acrylic / plastic / wood	150 – 200

Embossing on leather and PVC by stamping (without foil) can be done at higher temperature and pressure.

Adjustment of Stamping Stroke

If you pull the OPERATING HANDLE too hard, the surface of the Type/Engraving will clash with the material to be printed and cause damage. The TC-851 is equipped with a stamping stroke adjustment system to control the downstroke of the type/engraving holder. It provides a suitable stamping clearance between the surface of type/engraving and material to be printed (having various thicknesses).

1. Pull the OPERATING HANDLE until the surface of the type/engraving touches the printing object. It can be achieved by loosening the FIXING NUT and turning the ADJUSTING NUT clockwise or anticlockwise to increase or decrease the stroke clearance.
2. When the desired stroke depth is achieved, you can lock the stroke depth by turning the FIXING NUT in a clockwise direction until it is tightened. This will provide a suitable clearance and stable pressure for every operation. This will be helpful especially when fragile articles are to be printed.
3. When printing paper, always allow enough stroke depth.
4. Always allow a large stroke depth for rugged surfaces because they need higher printing pressure.

Set Engraving

1. Place the Engraving Holder with the 2 Holder Handle Sockets toward you.
2. Stick the Engraving onto Engraving Holder using double sided adhesive tape.
3. The appearance of Engraving would then be in reverse mode.

REMARK:

- Adhesive tape has to be stuck evenly.
- Engravings can be removed by means of cleaning spirit or peeled off with a knife.
- Be careful, do not bend or scratch the Engravings, for it would cause damage to the surface.

Type Setting

1. - Place the Type Holder sloped with th 2 Holder Handle Sockets towards you.
 - Feed in Lead Rules.
2. - Fill in type with nicks facing you.
 - Fill in Spacers between words/letters and at the ends of each line.
 - Separate lines by Lead Rules and/or Short Lead Rules.
3. Use Allen Key to tighten the set-up Type vertically by driving Allen Screws on upper and lower sides of Type Holder.

Type Setting:

It is the procedure to place each piece of Type into a Chase that holds the Type together. The chase is also referred to as a Type Holder. Please rest assured that there is nothing special in setting Type. As one gains experience in setting Type, different ways of shortening the process will become apparent.

- Place the Type Holder sloped towards you and make the 2 Holder Handle Sockets facing you.
- Place one, two or more Lead Rules into the lower parts of Type Holder depending on the vertical size of the printing area you require to print.
- The Type is set line by line in the reverse sequence of the copy. This means that you start with the last word in the last line and end with the first word of the first line.
- When setting Type into the Type Holder, the nick of every Type should face downward, thus making the letters appear in reverse mode.
- Although it is the Type itself that actually makes the printed impression, the spaces at the ends of each line and those between words and/or letters must be filled up with spacers that do not actually show up as print.
- The Spacers that fit between words come in different width. Point spacers should be used with 12 point types, 14 point spacers with 14 point type, etc.
- Lead Rules are strips of metal that are used to increase the space between lines. It will also prevent the next line from mixing with previously set Type. They vary in thickness and are cut to various lengths.
- Check with your finger to ensure each line of Type is properly tightened. Don't use Tweezers, for they will scratch the Type. If a line is loose, insert additional thin Spacers as required.

- After the Type setting is completed, first use the Allen Key to tighten the set-up Type vertically by driving the 4 pieces of the Allen Screws located at the upper and lower sides of Type Holder or by driving the Adjustable Spacers.
- To tighten ONLY the lines of Types horizontally, drive Allen Screws corresponding to its ends.
- Adding Spacers to one line may loosen another, so be careful to keep thin Spacers away from end slugs.
- In order to load and/or unload set-up Type efficiently, it is recommended to use Adjustable Lead Rules instead of Short Lead Rules.
- Use your finger to depress the Type. Make sure that the feel of all Type is in good contact with Type Holder before printing.
- Never try to allow printing temperature to exceed 300C for types printing.

Installation of Type/Engraving Holder

1. Loosen the fixing SCREWS on both sides of the HEATING BLOCK.
2. Turn the TYPE/ENGRAVING HOLDER upside down. (TYPE/ENGRAVING FACING DOWNWARD)
3. Place the TYPE/ENGRAVING HOLDER into the TYPE/ENGRAVING RACK.
4. Push the TYPE/ENGRAVING HOLDER against the main body until it is in position with the HEATER BLOCK.
5. Fix the TYPE/ENGRAVING HOLDER in position by tightening the FIXING SCREWS on both sides of the heating block.

Type/Engraving Holder Leveling

Adjust the four LEVELING SCREWS for balancing and adjusting the required level of the BALANCING PLATE for perfect imprinting.

1. Type/Engraving Holder unlevelled
Adjust leveling screws (Please refer to – Type/Engraving Holder Leveling)
2. Surfaces of type and/or engraving damaged
Replace the damaged ones.
3. Different heights (very slightly) between individual types. Stick adhesive tape over the unclear parts of the test print.

HINTS FOR ENGRAVING/PRINTING

Due to the thinness of Engraving, an unnecessary foil emulsive frequently is stamped around the printing area, especially when printing plastic sheets, when the problem is more inevitable. To avoid this problem, apply an aluminum rest between Engraving and the Engraving Holder.

- Prepare the matching Engraving Rest.
- Use double sided adhesive tape to stick Engraving onto Engraving Rest.
- Stick the other side of the Engraving Rest to Engraving Holder.

DISLOCATION OF FOIL ADVANCING

During the printing process, foil sheet may occasionally roll outside either side of the Rubber Roller. In case this happens, please check the following points:

CIRCUIT DIAGRAM OF TC-851

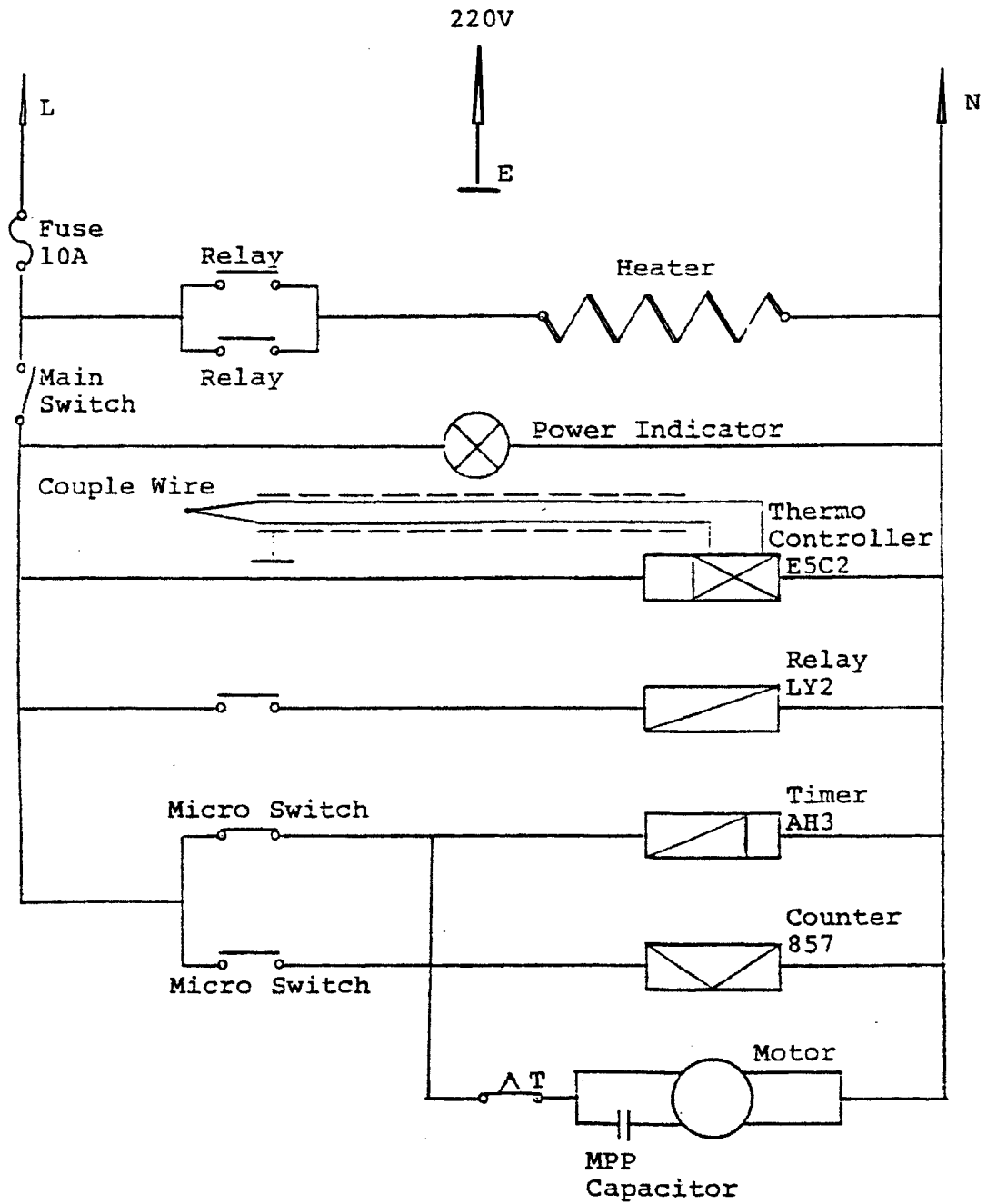

Applying Silicone Pad to your KOBO TC 851

Be sure to clean both the back of the silicone pad and underside of heat plate with denatured alcohol.

Place the silicone pad FACE DOWN on the TC-851 worktable.

Push work table in until under heat plate and align pad squarely underneath.

Adjust the heat plate to lowest position so that pressure can be applied to silicone pad while lying flat on the worktable.

Pull table out so adhesive can be applied to back of silicone (below).

Peel heat activated adhesive from line

Note: If too warm, it will soften, stick and be very difficult to apply flat.

Lay strips of adhesive across the aluminum back of silicone pad. Be certain the adhesive lies flat.

Once adhesive is placed on pad, turn on the TC-851 and allow to heat as normal.

After proper stamping temperature is reached, push worktable in so the pad returns to the aligned position under the heat plate.

Lower the heat plate and apply pressure for ONE MINUTE to ensure proper adhesion.

