

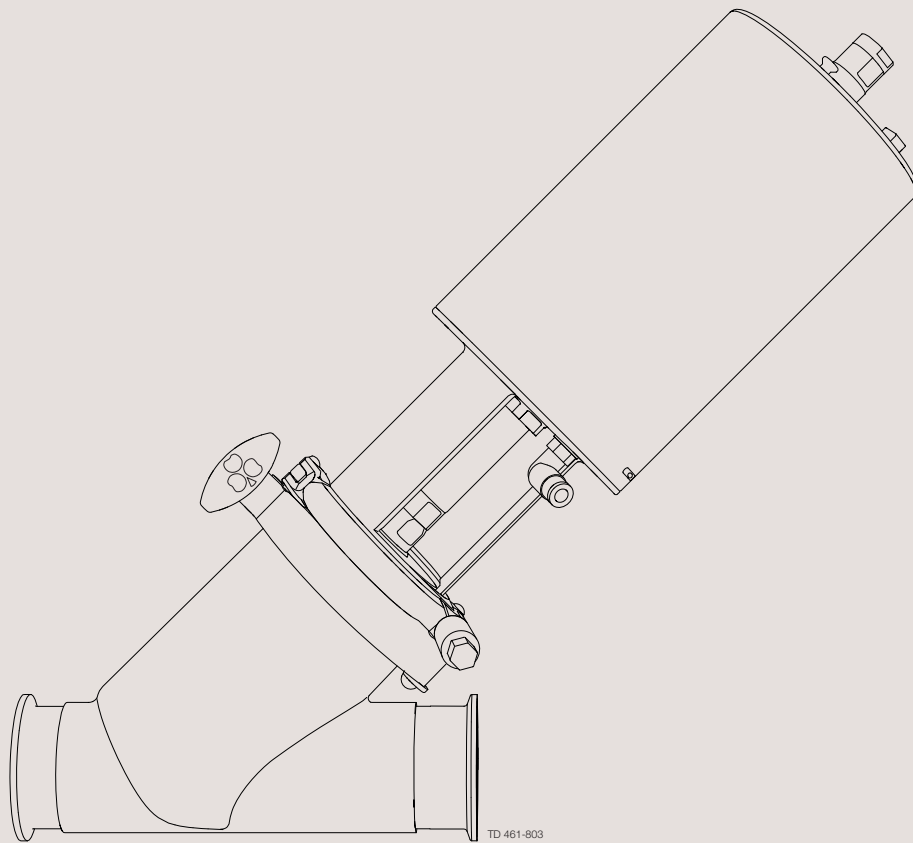

# Instruction Manual

## Unique SSV Valve Y-body



TD 461-803

ESE00690-ENUS5 2019-03

Original manual



The information herein is correct at the time of issue but may be subject to change without prior notice

<b>1. EC Declaration of Conformity</b> .....	<b>4</b>
<b>2. Safety</b> .....	<b>5</b>
2.1. Important information .....	5
2.2. Warning signs .....	5
2.3. Safety precautions .....	6
<b>3. Installation</b> .....	<b>8</b>
3.1. Unpacking/delivery .....	8
3.2. General installation .....	9
3.3. Welding .....	11
3.4. Recycling information .....	12
<b>4. Operation</b> .....	<b>13</b>
4.1. Operation .....	13
4.2. Troubleshooting .....	15
4.3. Recommended cleaning .....	16
<b>5. Maintenance</b> .....	<b>18</b>
5.1. General maintenance .....	18
5.2. Dismantling of valve .....	20
5.3. Plug Seal replacement .....	20
5.4. Valve assembly .....	21
5.5. Actuator bushing replacement .....	21
<b>6. Technical data</b> .....	<b>22</b>
6.1. Technical data .....	22
<b>7. Parts list and Service Kits</b> .....	<b>23</b>
7.1. Unique SSV Valve - Y-body .....	23

# 1 EC Declaration of Conformity

Revision of Declaration of Conformity 2009-12-29

The Designated Company

Alfa Laval Kolding A/S

Company Name

Albuen 31, DK-6000 Kolding, Denmark

Address

+45 79 32 22 00

Phone No.

hereby declare that

Valve

Designation

Unique SSV PN10

Type

From serial number 1000000 to 70000000000

is in conformity with the following directive with amendments:

- Machinery Directive 2006/42/EC
- Regulation (EC) No 1935/2004
- Pressure Equipment Directive 97/23/EC category 1 and subjected to assessment procedure Module A.

The person authorised to compile the technical file is the signer of this document

Global Product Quality Manager  
Pumps, Valves, Fittings and Tank Equipment

Title

Lars Kruse Andersen

Name

Kolding

Place

2016-12-03

Date

Signature



*Unsafe practices and other important information are emphasized in this manual.  
Warnings are emphasized by means of special signs.*

---

### 2.1 Important information

---

**Always read the manual before using the valve!**

**WARNING**

Indicates that special procedures must be followed to avoid serious personal injury.

**CAUTION**

Indicates that special procedures must be followed to avoid damage to the valve.

**NOTE**

Indicates important information to simplify or clarify procedures.

---

### 2.2 Warning signs

---

General warning:



Caustic agents:



## 2 Safety

All warnings in the manual are summarized on this page.

Pay special attention to the instructions below so that severe personal injury and/or damage to the valve are avoided.

### 2.3 Safety precautions

#### Actuators

If support air is utilised:



- Shock in the actuator must **NEVER** occur
- Support air on high pressure actuator versions is **NOT** allowed

To prevent shock in the actuator and to prevent exceeding 145 PSI (10 bar) product pressure, Alfa Laval recommends **NOT** to exceed 43.5 PSI (3 bar) support air on the spring side in all the Unique SSV actuators.

If support air is connected always use the 43 PSI (3 bar) air relief fittings = 9611996094 (1/4" = 6,35 mm hose)  
Using the 43.5 PSI (3 bar) air relief fitting also extends the service life of the actuator piston o-ring.  
Obs. if using a 6 mm hose then use air relief fittings = 9611995903

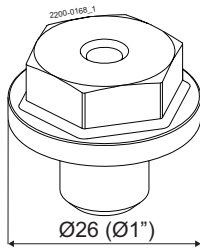

#### Pos. no. 5

For actuators, manufactured year 2005-2018, with serial number from 1000000 - 5999999 and from 200000000000 - 599999999999 always use steel adapter (pos 5) = 9614065301  
Tighten torque = 23 lbf-ft (30 Nm)

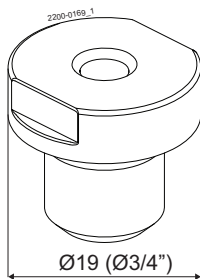

#### Pos. no. 5

For actuators, manufactured year 2019 --> with serial number from 6000000 to 7000000 and from 600000000000 to 700000000000 always use steel adapter (pos 5) = 9615374701  
Tighten torque = 11 lbf-ft (15 Nm)

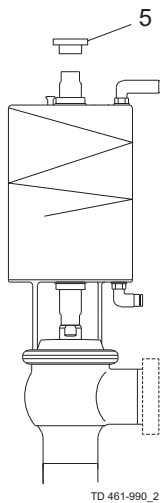

Alfa Laval recommends max. 43,5 PSI (3 bar) support air  
Always use the 43,5 PSI (3 bar) air relief fittings" on support air.  
Alfa Laval article number = 9611996094 (1/4" = 6,35 mm hose)

TD 461-990\_2

All warnings in the manual are summarized on this page.

Pay special attention to the instructions below so that severe personal injury and/or damage to the valve are avoided.

---

### Installation:

**Always** read the technical data thoroughly (See chapter 6 Technical data)

**Always** release compressed air after use

**Never** touch the moving parts if the actuator is supplied with compressed air

**Never** touch the valve or the pipelines when processing hot liquids or when sterilizing

**Never** dismantle the valve with valve and pipelines under pressure

**Never** dismantle the valve when it is hot



---

### Operation:

**Never** dismantle the valve with valve and pipelines under pressure

**Never** dismantle the valve when it is hot

**Always** read the technical data thoroughly (See chapter 6 Technical data)

**Always** release compressed air after use

**Never** touch the valve or the pipelines when processing hot liquids or when sterilizing

**Never** touch the moving parts if the actuator is supplied with compressed air

**Always** rinse well with clean water after the cleaning



**Always** handle lye and acid with great care



---

### Maintenance:

**Always** read the technical data thoroughly (See chapter 6 Technical data)

**Always** release compressed air after use

**Never** service the valve when it is hot

**Never** service the valve with valve and pipelines under pressure

**Never** stick your fingers through the valve ports if the actuator is supplied with compressed air

**Never** touch the moving parts if the actuator is supplied with compressed air



### 3 Installation

---

The instruction manual is part of the delivery. Study the instructions carefully.

The items refer to parts list and service kits section.

The valve is supplied as separate parts as standard (for welding).

The valve is assembled before delivery, if it is supplied with fittings.

---

#### 3.1 Unpacking/delivery

---

##### Step 1

##### CAUTION

Alfa Laval cannot be held responsible for incorrect unpacking.

##### Check the delivery for:

1. Complete valve, shut-off valve (RA) or change-over valve (RA) (see steps 2a and 2b).
  2. Delivery note.
  3. Instruction manual.
- 

##### Step 2

Complete actuator

1. Bonnet (20).
2. upper clamp (19).
3. Valve plug (36).
4. Valve body (22).
5. Lower clamp (61)

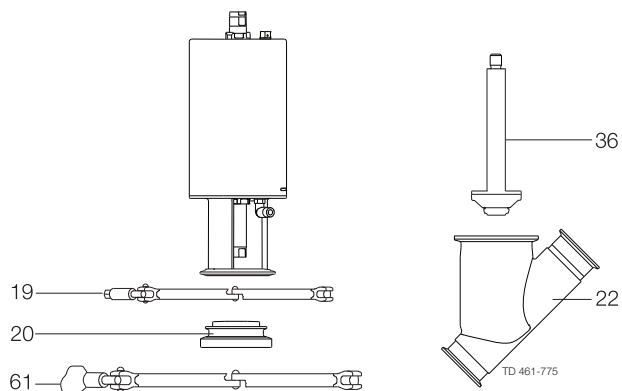

##### Step 3

Remove possible packing materials from the valve/valve parts.

Inspect the valve/valve parts for visible transport damages.

Avoid damaging the valve/valve parts.

---



Study the instructions carefully and pay special attention to the warnings!  
The valve has welding ends as standard but can also be supplied with fittings.

#### 3.2 General installation

##### Step 1



**Always** read the technical data thoroughly.  
See chapter 6 Technical data



**Always** release compressed air after use.

##### CAUTION

Alfa Laval cannot be held responsible for incorrect installation.

##### Step 2



**Never** touch moving parts if the actuator is supplied with compressed air.

Moving parts!

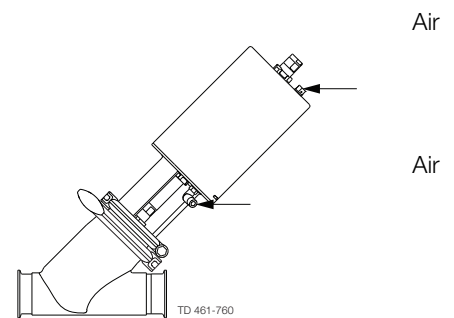

##### Step 3

It is recommended to install the valve so that the flow is against the closing direction to avoid water hammering.

Avoid water hammering!

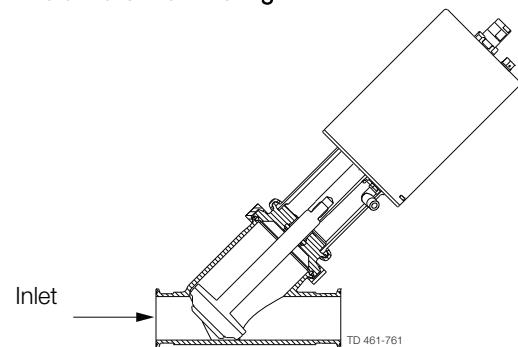

### 3 Installation

---

Study the instructions carefully and pay special attention to the warnings!

The valve has welding ends as standard but can also be supplied with fittings.

---

#### Step 4

Avoid stressing the valve.

**Pay special attention to:**

- Vibrations.
- Thermal expansion of the pipelines.
- Overloading of the pipelines.

**Risk of  
damage!**

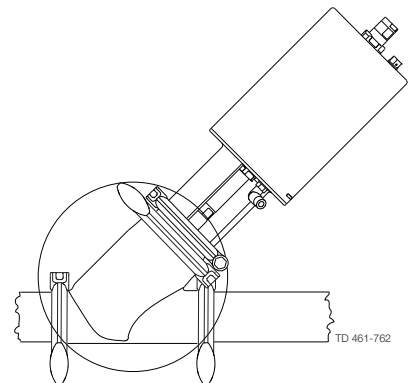

#### Step 5

Make sure that the leak detection hole in the valve body:

1. is visible, when mounting the valve vertically
2. always is downwards due to self-draining, when the valve is mounted horizontally.

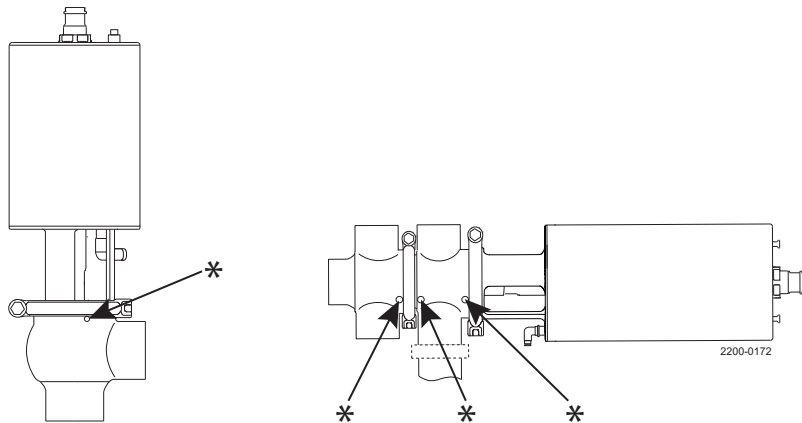

\* = Leakage detection hole

---

Study the instructions carefully.  
 The valve is supplied as separate parts to facilitate the welding.  
 The items refer to the parts list and service kits section.  
 Check the valve for smooth operation after welding.

## 3.3 Welding

### Step 1

**Always** install valves with more than one valve body so that the seals between the valve bodies can be replaced. Do not weld more than one valve body into the system.

Valve size	A (inch)	B (inch)
2"	*	18.8
2 ½"	*	19.3
3"	*	22.2
4"	*	23.8

\* Depending on body combination and piping solution.

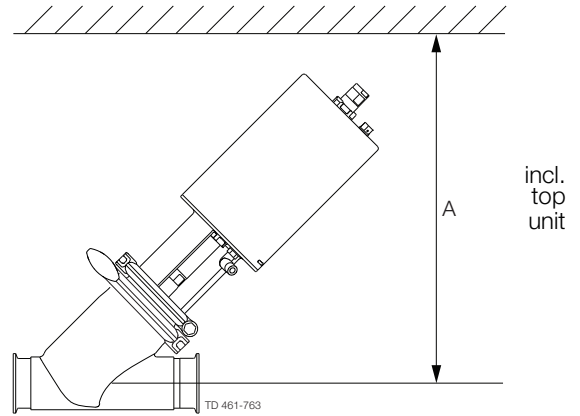

### Step 2

Assemble the valve in accordance with the steps on page .  
**Pay special attention to the warnings!**

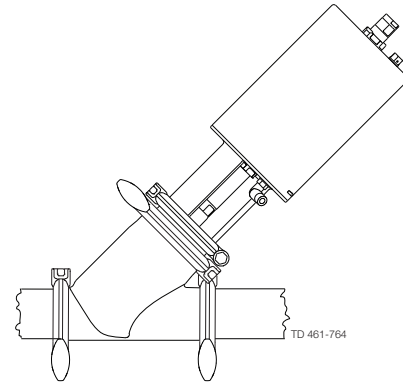

### Step 3

#### Pre-use check:

1. Supply compressed air to the actuator.
2. Open and close the valve several times to ensure that it operates smoothly.

**Pay special attention to the warnings!**

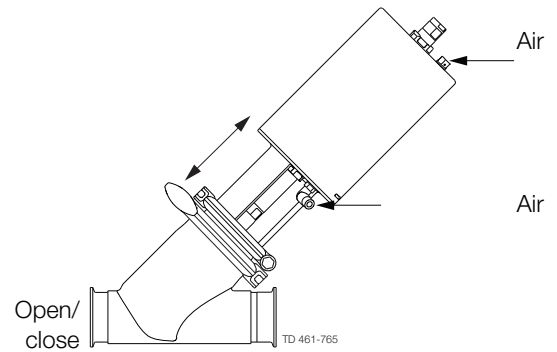

## 3 Installation

---

*Study the instructions carefully.*

*The valve is supplied as separate parts to facilitate the welding.*

*The items refer to the parts list and service kits section.*

*Check the valve for smooth operation after welding.*

---

### 3.4 Recycling information

---

- **Unpacking**

- Packing material consists of wood, plastics, cardboard boxes and in some cases metal straps
- Wood and cardboard boxes can be reused, recycled or used for energy recovery
- Plastics should be recycled or burnt at a licensed waste incineration plant
- Metal straps should be sent for material recycling

- **Maintenance**

- During maintenance oil and wear parts in the machine are replaced
- All metal parts should be sent for material recycling
- Worn out or defective electronic parts should be sent to a licensed handler for material recycling
- Oil and all non metal wear parts must be taken care of in agreement with local regulations

- **Scrapping**

- At end of use, the equipment shall be recycled according to relevant, local regulations. Beside the equipment itself, any hazardous residues from the process liquid must be considered and dealt with in a proper manner. When in doubt, or in the absence of local regulations, please contact the local Alfa Laval sales company
-

Study the instructions carefully and pay special attention to the warnings!  
 Ensure that the valve operates smoothly.  
 The items refer to the parts list and service kits section.

### 4.1 Operation

#### Step 1



**Always** read the technical data thoroughly.  
 See chapter 6 Technical data



**Always** release compressed air after use.

#### CAUTION

Alfa Laval cannot be held responsible for incorrect operation.

#### Step 2



**Never** touch the valve or the pipelines when processing hot liquids or when sterilizing.

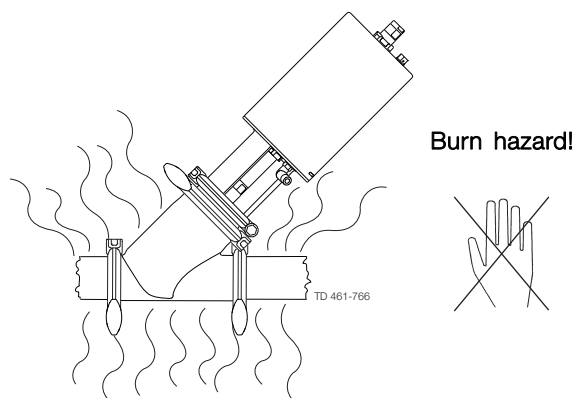

#### Step 3



**Never** touch the moving parts if the actuator is supplied with compressed air.

**Moving parts!**

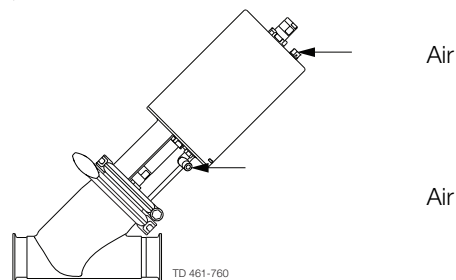

#### Step 4

##### Lubrication of valves:

1. Ensure smooth movement between lip seal (25) and plug stem (36).
2. Lubricate the lip seal with Klüber Paraliq GTE 703 if necessary (see section 5.1).

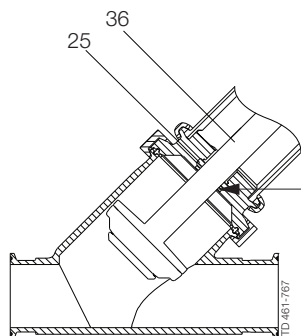

## 4 Operation

---

*Study the instructions carefully and pay special attention to the warnings!*

*Ensure that the valve operates smoothly.*

*The items refer to the parts list and service kits section.*

---

### Step 5

#### Lubrication of actuator

1. Ensure smooth movement of the actuator (the actuator is lubricated before delivery).
2. Lubricate all seals with Molykote Longterm 2 plus if necessary.

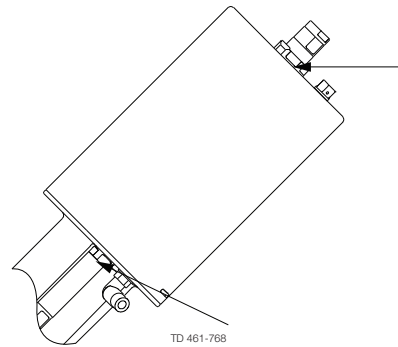

Pay attention to possible faults. Study the instructions carefully.  
The items refer to the parts list and service kits section.

## 4.2 Troubleshooting

### NOTE!

Study the maintenance instructions carefully before replacing worn parts. - See section 5.1!

Problem	Cause/result	Repair
External product leakage	Worn or product affected lip seal and/or O-ring	<ul style="list-style-type: none"> <li>- Replace the seals</li> <li>- Replace with seals of a different rubber grade</li> </ul>
Internal product leakage	<ul style="list-style-type: none"> <li>- Worn or product affected plug seal</li> <li>- Product deposits on the seat and/or plug</li> <li>- Product pressure exceeds actuator specification</li> </ul>	<ul style="list-style-type: none"> <li>- Replace the seal</li> <li>- Frequent cleaning</li> <li>- Replace with a high pressure actuator</li> <li>- Use auxiliary air on the spring side (do not exceed 43.5 PSI (3 bar)) Alfa Laval article number = 9611996094 . See section and section , step 4.</li> <li>- Reduce product pressure</li> </ul>
Water hammer	The flow direction is the same as the closing direction	<ul style="list-style-type: none"> <li>- The flow direction should be against the closing direction</li> <li>- Throttle air release of solenoid in top unit</li> </ul>
The valve does not open/close	Product pressure exceeds actuator specification	<ul style="list-style-type: none"> <li>- Replace with a high pressure actuator</li> <li>- Reduce product pressure</li> <li>- Use auxiliary air on the spring side. Always use the pressure relief fittings 43.5 PSI (3 bar) on support side. Alfa Laval article number = 9611996094</li> </ul>

If marked with a danger warning, do **NOT** attempt to cut the actuator open, due to spring under load.

## 4 Operation

The valve is designed for cleaning in place (CIP). CIP = Cleaning In Place.  
Study the instructions carefully and pay special attention to the warnings!  
NaOH = Caustic Soda.  
HNO<sub>3</sub> = Nitric acid.

### 4.3 Recommended cleaning

#### Step 1



Always handle lye and acid with great care.

Caustic danger!



Always use  
rubber gloves!



Always use  
protective goggles!

#### Step 2



Never touch the valve or the pipelines when sterilizing.

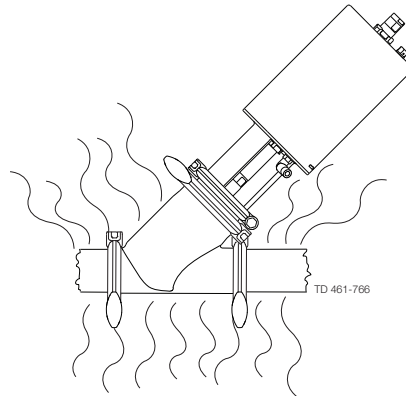

Burn hazard!

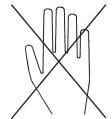

#### Step 3

Clean the plug and the seats correctly.  
Pay special attention to the warnings!  
Lift and lower valve plug momentarily!

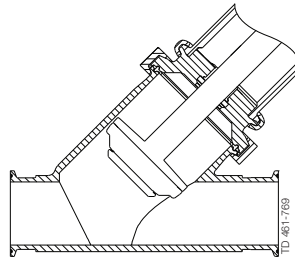

#### Step 4

Examples of cleaning agents:

Use clean water, free from chlorides.

1. 1% by weight NaOH at 158°F

$$\begin{array}{|c|} \hline 2.2 \text{ lb} \\ \hline \text{NaOH} \\ \hline \end{array} + \begin{array}{|c|} \hline 26.4 \text{ gal} \\ \hline \text{water} \\ \hline \end{array} = \text{Cleaning agent.}$$

$$\begin{array}{|c|} \hline 0.6 \text{ gal} \\ \hline 33\% \text{ NaOH} \\ \hline \end{array} + \begin{array}{|c|} \hline 26.4 \text{ gal} \\ \hline \text{water} \\ \hline \end{array} = \text{Cleaning agent.}$$

2. 0.5% by weight HNO<sub>3</sub> at 158°F

$$\begin{array}{|c|} \hline 0.2 \text{ gal} \\ \hline 53\% \text{ HNO}_3 \\ \hline \end{array} + \begin{array}{|c|} \hline 26.4 \text{ gal} \\ \hline \text{water} \\ \hline \end{array} = \text{Cleaning agent.}$$



The valve is designed for cleaning in place (CIP). CIP = Cleaning In Place.  
Study the instructions carefully and pay special attention to the warnings!  
NaOH = Caustic Soda.  
HNO<sub>3</sub> = Nitric acid.

---

### Step 5

1. Avoid excessive concentration of the cleaning agent.
2. Adjust the cleaning flow to the process.
3. **Always** rinse well with clean water after the cleaning.

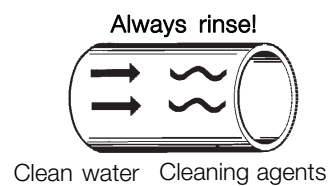

---

### Step 6

#### NOTE

The cleaning agents must be stored/disposed of in accordance with current regulations/directives.

---

# 5 Maintenance

Maintain the valve regularly.  
Study the instructions carefully and pay special attention to the warnings!  
Always keep spare rubber seals and lip seals in stock.

## 5.1 General maintenance

### Step 1



**Always** read the technical data thoroughly.  
See chapter 6.



**Always** release compressed air after use.

### NOTE

All scrap must be stored/discharged in accordance with current rules/directives.

### Step 2



**Never** service the valve when it is hot.



**Never** service the valve with valve and pipelines under pressure.

**Atmospheric pressure required!**

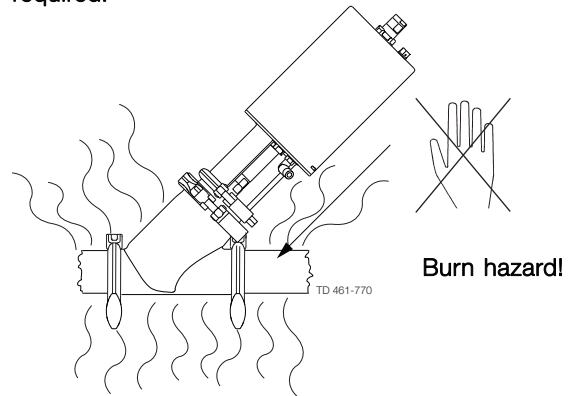

### Step 3



**Never** stick your fingers through the valve ports if the actuator is supplied with compressed air.



**Never** touch the moving parts if the actuator is supplied with compressed air.

**Moving parts!**

**Cutting hazard!**

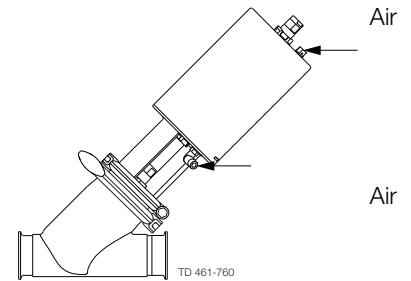

Maintain the valve regularly.  
 Study the instructions carefully and pay special attention to the warnings!  
 Always keep spare rubber seals and lip seals in stock.

Below are some guidelines for maintenance and lubrication intervals. Please note that the guidelines are for normal working conditions in one shift.

	Product wetted seals	Actuator bushings complete
Preventive maintenance	Replace after 12 months depending on working conditions	Replace after 5 years depending on working conditions
Maintenance after leakage (leakage normally starts slowly)	Replace at the end of the day	Replace when possible
Planned maintenance	<ul style="list-style-type: none"> <li>- Regular inspection for leakage and smooth operation</li> <li>- Keep a record of the valve</li> <li>- Use the statistics for planning of inspections</li> </ul> <b>Replace after leakage</b>	<ul style="list-style-type: none"> <li>- Regular inspection for leakage and smooth operation</li> <li>- Keep a record of the actuator</li> <li>- Use the statistics for planning of inspections</li> </ul> <b>Replace after leakage</b>
Lubrication	<b>Before fitting</b> Klüber Paraliq GTE 703 or similar USDA H1 approved oil/grease	<b>Before fitting</b> Molykote Longterm 2 plus

**Pre-use check:**

1. Supply compressed air to the actuator.
  2. Open and close the valve several times to ensure that it operates smoothly.
- Pay special attention to the warnings!**

Open/close!

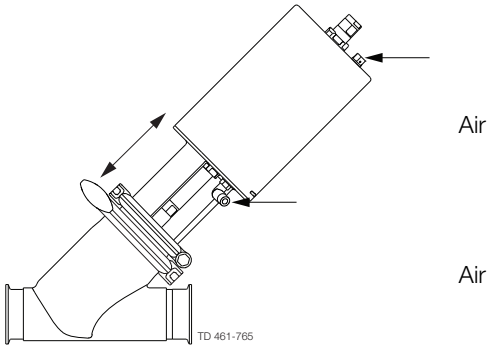

## 5 Maintenance

Study the instructions carefully. The items refer to the parts list and service kits section. Handle scrap correctly.

NC = Normally closed.

NO = Normally open.

A/A = Air/air activated.

### 5.2 Dismantling of valve

#### Step 1

1. Supply compressed air to the actuator (only NC).
2. Loosen and remove upper clamp.
3. Release compressed air (only NC).
4. Lift away the actuator.
5. Remove body gasket.
6. Unscrew and remove valve plug.
7. Loosen and remove upper clamp.
8. Remove O-ring, lip seal and bushing in bonnet.  
(Use bushing tool and rubber mallet. See drawing).

**Pay special attention to the warnings!**

**Note!** For plug seal replacement please see section 5.3.

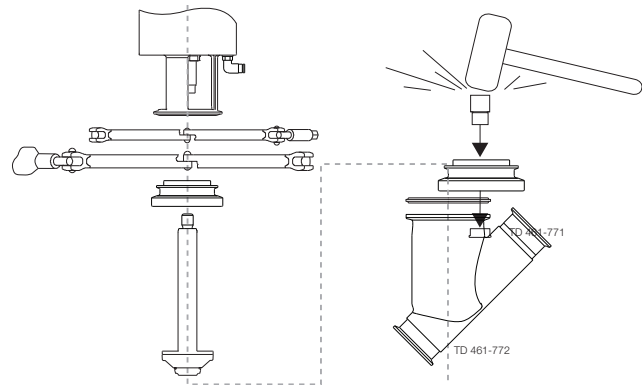

**Note!**

Be careful not to damage the bushing.

### 5.3 Plug Seal replacement

#### TR2 seal ring replacement

1. Place the plug element on a firm support.
2. Using a utility knife, partially AND CAREFULLY cut through the upper ring portion of the TR2 plug avoiding contact with stainless steel stem.
3. Force apart both cut ends of the plug for removal from stem.
4. TR2 plugs are installed by applying uniform pressure on all sides.  
(Pressure can be applied by using the seat assembly tool).
5. Using a piece of metal and a rubber mallet, place a precise tab to make the TR2 plug snap on to the stem. Reverse the tool and tab again to secure proper fit.
6. Examine seat assembly to be sure the TR2 plug is properly mounted, holding the seat assembly in one hand - rotate the TR2 plug.  
(For proper CIP cleaning the TR2 plug should turn freely on the stem.)

For more explicit instructions, please refer to the maintenance video.

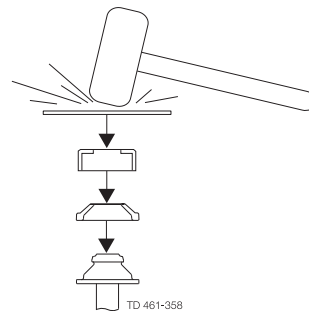

Study the instructions carefully.

The items refer to the parts list and service kits section. Handle scrap correctly.

A/A = Air/air activated.

Service tool: See Spare Parts.

### 5.4 Valve assembly

Reverse order of .

Lubricate O-ring (21) and lip seal (25) with Klüber Paraliq GTE 703.

Remember to tighten spindle and plug (use two 17 mm spanners).

- Change-over plug tighten torque = **22 lbf - ft (30 Nm)**
- Shut-off plug tighten torque = **15 lbf - ft (20 Nm)**

If there are vibrations in the pipeline Alfa Laval recommend to use loctite nr. 243.

The clamps thread must be lubricated before tightening - max. torque for the clamps is 8-9 lbf - ft (10-12 Nm).



Pay special attention to the warnings.

### 5.5 Actuator bushing replacement

1. Unscrew and remove top and bottom bushings with O-rings.
2. Lubricate O-rings with Molykote Longterm 2 plus before fitting.
3. Fit bushings and O-rings. Tighten brushing with a torque = 7 lbf-ft (10Nm).  
Be careful not to overtighten.

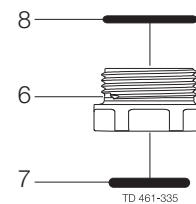

## 6 Technical data

---

*It is important to observe the technical data during installation, operation and maintenance.  
Inform the personnel about the technical data.*

---

### 6.1 Technical data

---

<b>Data - valve/actuator</b>	
Max. product pressure	145 PSI (1000 kPa) (10 bar)
Min. product pressure	Full vacuum (depending on product specifications)
Temperature range	14°F to + 284°F (standard EPDM seal)
Air pressure, actuator	72.5 to 101.5 PSI (500 to 700 kPa) (5 to 7 bar)
<b>Materials - valve/actuator</b>	
Product wetted steel parts	AISI 316L (internal Ra < 32 μ inch)
Other steel parts	AISI 304
Plug seal	EPDM / PTFE (TR2)
Other product wetted seals	EPDM (standard)
Optional product wetted seals	HNBR/NBR and FPM
Other seals	NBR

---

*It is important to observe the technical data during installation, operation and maintenance.  
Inform the personnel about the technical data.*

7.1 Unique SSV Valve - Y-body

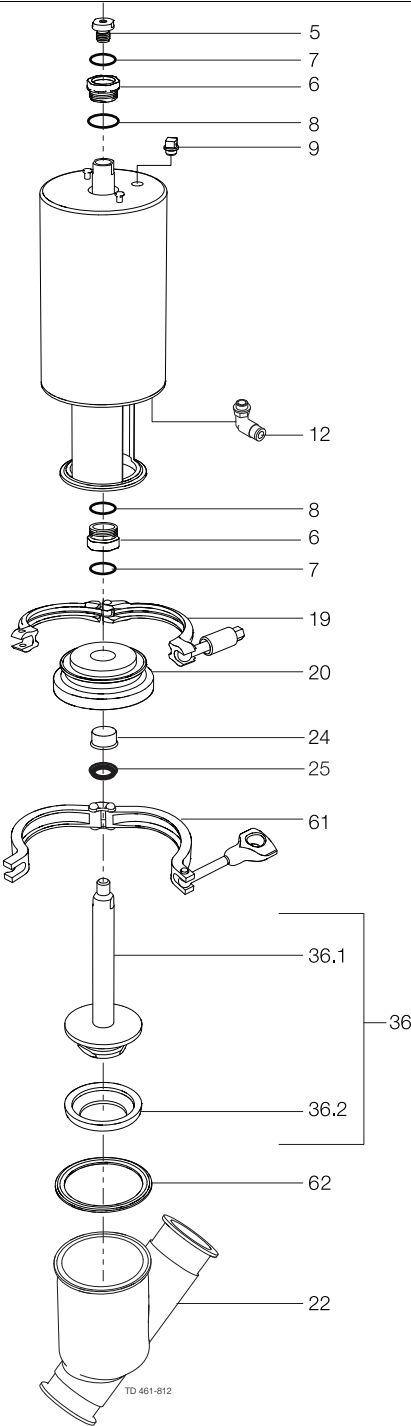

## 7 Parts list and Service Kits

*It is important to observe the technical data during installation, operation and maintenance.  
Inform the personnel about the technical data.*

### Parts list

Pos.	Qty	Denomination
5	1	Actuator Adapter
6 □	2	Bushing
7 □	2	O-ring
8 □	2	O-ring
9	1	Plug
12	1(2)	Air fitting
19	1	Clamp
20	1	Bonnet
22	1	Valve body
25 ♦	1	Lip seal
36	1	Plug
36.1	1	Plug
36.2 ♦	1	Plug seal
61	1	Clamp
62 ♦	1	Gasket

### Service kits

Denomination	2"	2½"	3"	4"
<b>Actuator</b>				
□ Service kit .....	9611926500	9611926500	9611926500	9611926500
<b>Product wetted parts</b>				
♦ Service kit, EPDM .....	9611926815	9611926816	9611926817	9611926818
♦ Service kit, HNBR/NBR .....	9611926819	9611926820	9611926821	9611926822
♦ Service kit, FPM .....	9611926823	9611926824	9611926825	9611926826

Recommended spare parts: Service kits

Parts marked with □♦ are included in the service kits.

TD900479/2





**How to contact Alfa Laval**

Contact details for all countries are continually updated on our website.

Please visit [www.alfalaval.com](http://www.alfalaval.com) to access the information directly.

© Alfa Laval Corporate AB

This document and its contents is owned by Alfa Laval Corporate AB and protected by laws governing intellectual property and thereto related rights. It is the responsibility of the user of this document to comply with all applicable intellectual property laws. Without limiting any rights related to this document, no part of this document may be copied, reproduced or transmitted in any form or by any means (electronic, mechanical, photocopying, recording, or otherwise), or for any purpose, without the expressed permission of Alfa Laval Corporate AB. Alfa Laval Corporate AB will enforce its rights related to this document to the fullest extent of the law, including the seeking of criminal prosecution.