

# INSTRUCTION MANUAL

## MONTAGUE **VECTAIRE**

### Gas Convection Ovens

**MODELS:**  
70, 115, R85, 2-70,  
2-115 & R2-85 Series

**These instructions should be read thoroughly before attempting installation.  
Set up and installation should be performed by qualified installation personnel.**

**Keep area around appliances free and clear from combustibles.**

**PLEASE RETAIN THIS MANUAL  
FOR FUTURE REFERENCE.**



**THE MONTAGUE COMPANY**  
1830 Stearman Avenue P.O. BOX 4954  
HAYWARD, CA 94540-4954  
TEL: 510/785-8822 FAX: 510/785-3342

## CONTENTS

INSTALLATION .....	3
OPERATION .....	11
COOKING HINTS .....	16

MAINTENANCE .....	21
SERVICE .....	26

# IMPORTANT

### **WARNING:**

**Improper installation, adjustment, alteration, service or maintenance can cause property damage, injury or death. Read the operating and maintenance instructions thoroughly before installing or servicing this equipment.**

### **FOR YOUR SAFETY:**

**Do not store or use gasoline or other flammable vapors and liquids in the vicinity of this or any other appliance.**

**INSTRUCTIONS TO BE FOLLOWED IN THE EVENT THE USER SMELLS GAS MUST BE POSTED IN A PROMINENT LOCATION. THIS INFORMATION MAY BE OBTAINED BY CONSULTING THE LOCAL GAS SUPPLIER.**

## **SHIPPING DAMAGE CLAIM PROCEDURE**

For your protection, please note that equipment in this shipment was carefully inspected and packed by skilled personnel before leaving the factory. The transportation company assumes full responsibility for safe delivery upon acceptance of this shipment.

### **If shipment arrives damaged:**

1. **VISIBLE LOSS OR DAMAGE**—Be certain this is noted on freight bill or express receipt, and signed by person making delivery.
2. **FILE CLAIM FOR DAMAGES IMMEDIATELY**—Regardless of the extent of damage.
3. **CONCEALED LOSS OR DAMAGE**—If damage is unnoticed until merchandise is unpacked, notify transportation company or carrier immediately, and file “concealed damage” claim with them. This should be done within fifteen (15) days of date that delivery was made to you. Be sure to retain container for inspection.

*We cannot assume responsibility for damage incurred in transit. We will, however, be glad to furnish you with necessary documents to support your claim.*

Vectaire gas convection ovens are manufactured for use with the type of gas and electric supply indicated on the nameplate behind the fire box panel.

The Vectaire oven is produced with the best possible material and workmanship. PROPER INSTALLATION IS ESSENTIAL FOR SAFE AND EFFICIENT TROUBLE-FREE OPERATION.

**THE INSTALLATION INSTRUCTIONS CONTAINED HEREIN ARE FOR THE USE OF QUALIFIED INSTALLATION AND SERVICE PERSONNEL ONLY. INSTALLATION OR SERVICE BY OTHER THAN QUALIFIED PERSONNEL MAY RESULT IN DAMAGE TO THE OVEN AND/OR INJURY TO THE OPERATOR.**

Qualified installation personnel are individuals, a firm, corporation or company which either in person, or through a representative are engaged in, and are responsible for:

- A. The installation or replacement of gas piping or the connection, installation, repair or servicing of equipment, who is experienced in such work, familiar with all precautions required, and has complied with all requirements of state or local authorities having jurisdiction. Reference: National Fuel Gas Code Z223.1-latest addenda, Section 1.4.
- B. The installation of electrical wiring from the electric meter, main control box or service outlet to the electric appliance. Qualified personnel must be experienced in such work, be familiar with all precautions required and have complied with all requirements of state and local authorities having jurisdiction. Reference: National Electric Code, N.F.P.A. No. 70-latest addenda.

**READ CAREFULLY AND FOLLOW THESE INSTRUCTIONS**

THE OVEN MUST BE INSTALLED IN ACCORDANCE WITH LOCAL CODES, OR IN THE ABSENCE OF LOCAL CODES, WITH THE NATIONAL FUEL CODE, ANSI Z223.1-LATEST ADDENDA, INCLUDING:

1. The appliance and its individual shutoff valve must be disconnected from the gas supply piping system during any pressure testing of that system at test pressures in excess of 1/2 psig. (3.45kPa).
2. The appliance must be isolated from the gas supply piping system by closing its individual manual shutoff valve during any pressure testing of the gas supply piping system at test pressure equal to or less than 1/2 psig. (3.45kPa).

**THIS UNIT WHEN INSTALLED MUST BE ELECTRICALLY GROUNDED IN ACCORDANCE WITH LOCAL CODES, OR IN ABSENCE OF LOCAL CODES, WITH THE NATIONAL ELECTRICAL CODE, ANSI/NFPA No.70-LATEST ADDENDA.**

**PROVISIONS MUST BE MADE FOR ADEQUATE AIR SUPPLY TO THE UNIT.**

## INSTALLATION

### Ventilating Hood

The ideal method of ventilating a convection oven is the use of a properly designed ventilating hood. The hood should extend at least 6" beyond all sides of the oven. The hood should be connected to an adequate mechanical exhaust system.

Information on the construction and installation of ventilating hoods may be obtained from the "Standard for the Installation of Equipment for the Removal of Smoke and Grease Laden Vapors from Commercial Cooking Equipment", NFPA No. 96– latest addenda, available from the National Fire Protection Association, Batterymarch Park, Quincy, MA 02269.

It is also necessary that sufficient room air ingress be allowed to compensate for the amount of air removed by the ventilating system. Otherwise, a subnormal atmospheric pressure will occur which may interfere with burner performance or may extinguish the pilot flame. In case of unsatisfactory oven performance, check with the exhaust fan in the "OFF" position.

### Direct Flue Connection

If the oven is connected directly to an outside flue, a draft hood P/N 04391-5 or 04392-3 for Model 70, 115, SE70 and SE115 series and P/N 03109-7 or 03099-6 for Model 2-70, 2-115, SE2-70 and SE2-115 series must be used. (See Fig. 2 & 5) The flue should rise at least 10 feet above the roof or any surrounding structure. The flue must be terminated with an U.L. listed vent cap or spinner.

### Clearances

Adequate clearance must be provided in the aisle and at the side and back to allow the doors to open sufficiently to permit the removal of the racks and for serviceability. Adequate clearance for air openings into the combustion chamber must be provided.

#### CLEARANCES

##### **MODEL 70, 115, SE70 & SE115 SERIES WITH ENCLOSED BASE & MODULAR STAND:**

	<u>COMBUSTIBLE CONSTRUCTION</u>	<u>NONCOMBUSTIBLE CONSTRUCTION</u>
Back:	6"	5"
Left & Right Side:	6"	0

WITH 4" OR 6" LEGS: SUITABLE FOR INSTALLATION ON COMBUSTIBLE FLOORS.

##### **MODEL 2-70, 2-115, SE2-70 & SE2-115 SERIES:**

	<u>COMBUSTIBLE CONSTRUCTION</u>	<u>NONCOMBUSTIBLE CONSTRUCTION</u>
Back:	6"	5"
Left & Right Side:	6"	0

WITH 4" OR 6" LEGS: SUITABLE FOR INSTALLATION ON COMBUSTIBLE FLOORS.  
CURB MOUNT WITH 1" TOE BASE (P/N: 555): FOR USE ONLY WITH NONCOMBUSTIBLE FLOORS.

### CAUTION

DO NOT OBSTRUCT THE FLOW OF COMBUSTION AND VENTILATION AIR TO THE OVEN. KEEP THE APPLIANCE AREA FREE AND CLEAR FROM COMBUSTIBLES

Solid state components have a very short life span when exposed to temperatures above 185°F (85° C), therefore, certain installation precautions are necessary. The “SE” ovens have been designed to operate below this temperature when properly installed. The following precautions must be observed:

1. Do not obstruct the flow of air through the vent openings at the top of the oven, or the flow of room air to the oven bottom or lower front portion of the burner access panel.
2. Do not mount the oven on a curb unless it has been equipped with the No.555 Toe Base (P/N:06024-0) for this type of installation.
3. When stacking ovens, never reverse the top and bottom oven sections.
4. Never stack an “SE” series convection oven with a standard Vectaire or another brand of oven without first consulting the factory. Certain ovens are not compatible, or a stacking kit may be required.

### SPECIAL CAUTION

DO NOT PLACE HIGH HEAT PRODUCING EQUIPMENT ADJACENT TO THE RIGHT SIDE OF AN “SE” VECTAIRE CONVECTION OVEN, OR ANY OVEN EQUIPPED WITH THE IFO FAN CONTROL. SURFACE TEMPERATURES EXCEEDING 185°F (85°C) CAN CAUSE PREMATURE COMPONENT FAILURE NOT COVERED UNDER MANUFACTURER’S WARRANTY.

## ASSEMBLY

Model 70, 115, SE70 & SE115 Series (Fig. 1 & 2)

Uncrate oven and base as near to final location as possible. Remove all packing material and accessories from oven interior. Install rack guides (if provided) in base. Place oven on stand as shown in Figure 1. Install flue deflector (P/N [16522-0](#) or [16532-8](#)) or draft hood (P/N [04391-5](#) or [04392-3](#)). Either a flue deflector or a draft hood is shipped with every unit. The flue deflector is intended for use when the oven is installed under a properly designed hood.

When oven is directly connected to vent system, the draft hood must be used. (See Figure 2 & 6). When oven is in permanent position, level entire unit by placing carpenter’s level on oven rack and adjusting the foot of the bottom of each leg so that oven is level from front to back and side to side.

# INSTALLATION

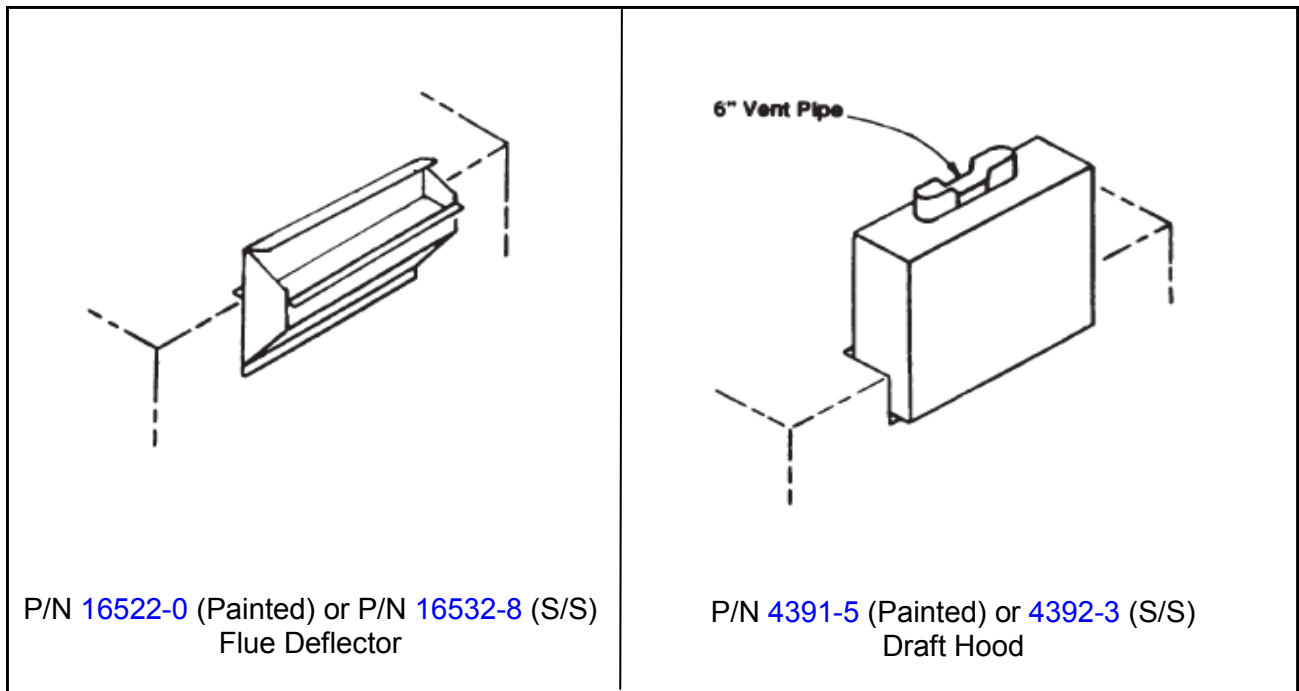
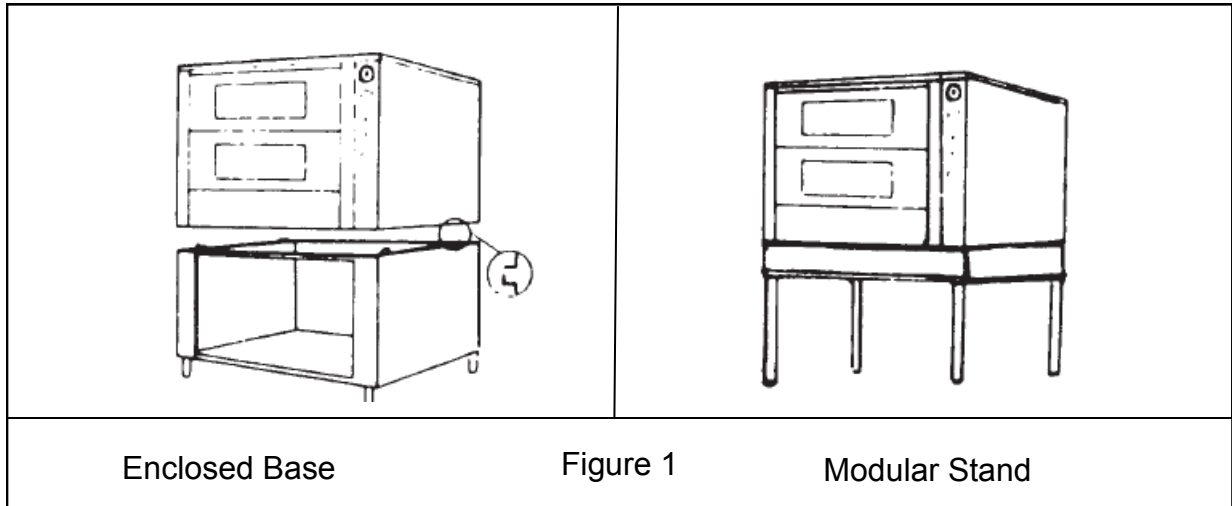

Figure 2

## Installation of Rack Guides in Base

-Kit No. 04651-5  
(If provided See Fig. 3)

1. Set base upright and place on rack guide in position with rod extensions toward rear and through holes in back.
2. Install stop (B) behind vertical flange forming base opening.
3. Place screw through clamp (A), upper hole of base flange (B) and stop. Install nut.
4. Repeat step 3 with lower hole of flange and stop. Tighten both nuts.
5. Repeat step 2, 3, and 4 for installation of other rack guide on opposite side.

Figure 3

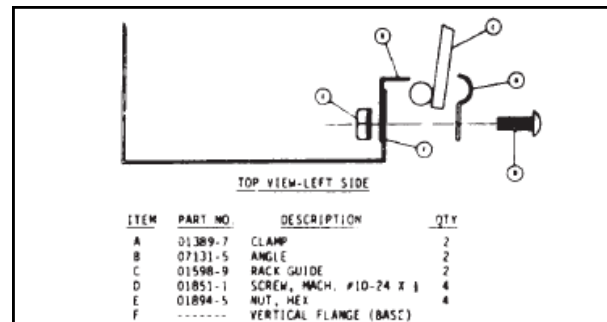

## Vectaire Models 2-70, 2-115, SE2-70 & SE2-115 Series (Fig. 4 & 5)

1. Screw the adjustable feet of the legs in all the way. Then tightly screw the complete leg assembly into the mounting holes at each corner of the lower dock (note logs on top of lower deck). If unit is intended for curb mounting, Toe Base (P/N:6024-0) must be used. The Toe Base is factory installed when curb mount is specified.
2. Set upper deck unit in place on top of lower deck.
3. Install flue riser (P/N:25128-3) over outlet of the horizontal flue collector (P/N:25135-6) of the lower deck. Secure in place with the screws that are provided. Install flue deflector (P/N:25328-6) over flue outlet of top oven section.
4. Install low profile deflector trim (P/N:26604-3) or draft hood (P/N:24678-6). Either a flue deflector or a draft hood is shipped with every unit. The flue deflector is intended for use when the oven is installed under a properly designed hood. When the oven is directly connected to the vent system, the draft hood must be used.
5. When oven is in permanent location, level entire unit by placing a carpenter's level on the oven rack and adjusting the foot on the bottom of each leg, so that the oven is level from front to back and side to side. Level a curb mounted unit by placing a shim under the slow side.

# INSTALLATION

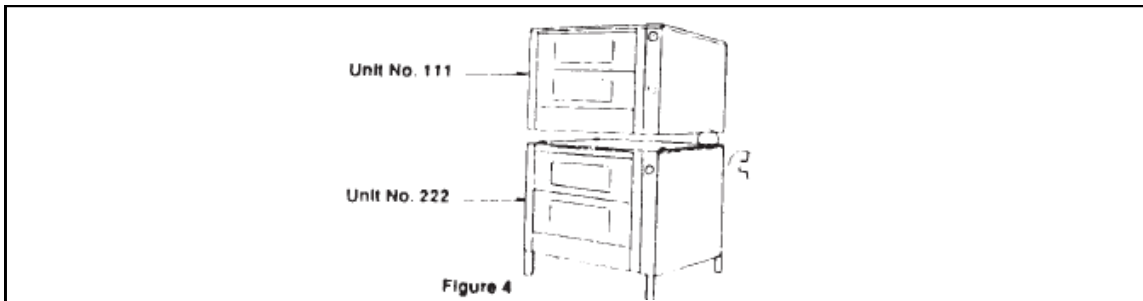

Figure 4

Figure 4

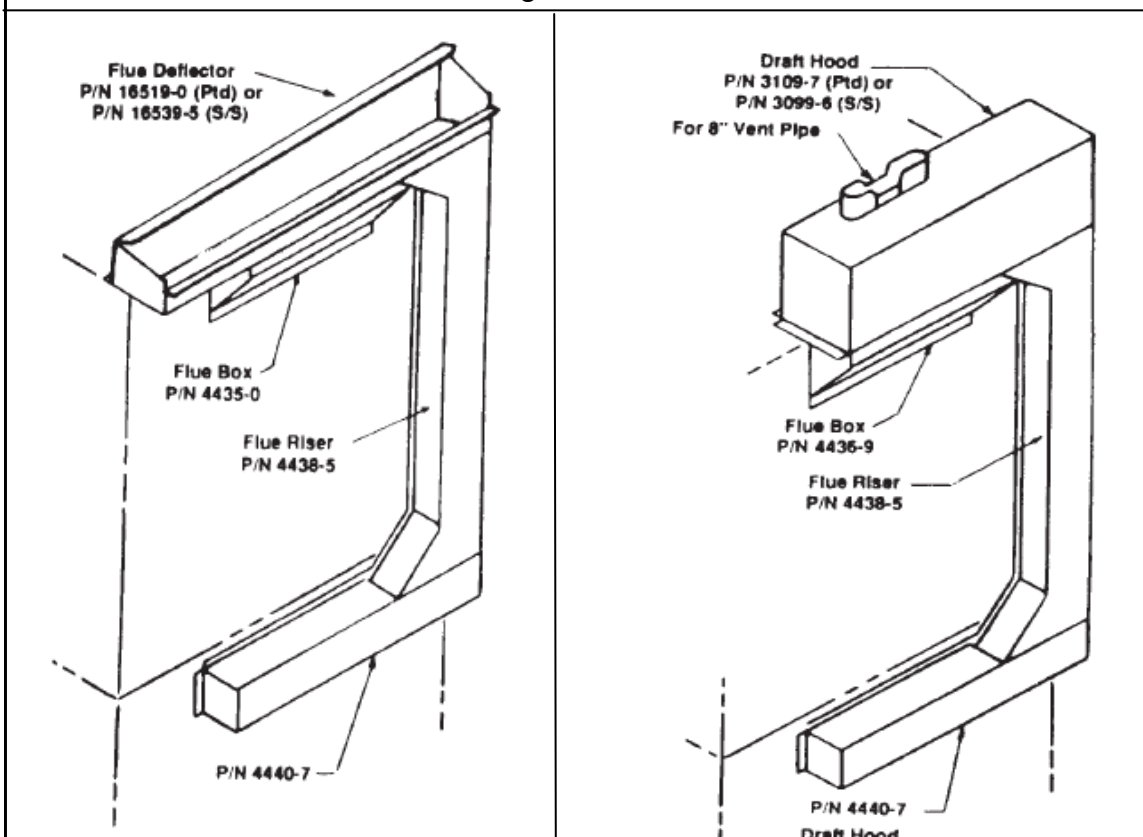

Figure 5

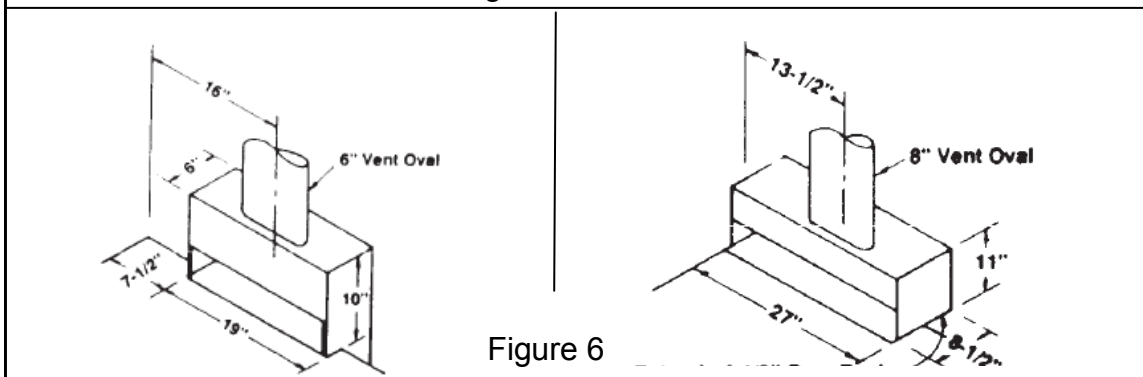

Figure 6



## GAS CONNECTION

Before connecting oven to the gas supply line, be sure that all new piping has been cleaned and purged to prevent any foreign matter from being carried into the controls by the gas. In some cases, filters or drops are recommended. A separate gas shutoff valve must be installed upstream from the gas pressure regulator adjacent to the oven and be located in an accessible area.

It is important that adequately sized piping be run directly to the point of connection at the oven, with as few elbows and tees as possible. Consult local gas company for proper piping size and gas pressure.

Each oven is equipped with an appliance gas pressure regulator. This gas pressure regulator is factory adjusted for the manifold pressure specified on the name plate.

THIS OVEN IS DESIGNED FOR USE WITH A GAS PRESSURE REGULATOR. THE REGULATOR SUPPLIES WITH THIS UNIT MAY BE USED.

For Natural Gas: This pressure regulator is factory adjusted for 3.5" W.C. manifold pressure. The maximum inlet pressure to the regulator should not exceed 10.5" water column.

For Propane Gas: This gas pressure regulator is factory adjusted for 10" W.C. manifold pressure. The maximum inlet pressure to the regulator should not exceed 21" water column.

Connect the gas supply line from the service gas shutoff valve to the inlet side of the gas pressure regulator using 3/4" pipe. If flexible or semi-flexible connectors are used, an AGA Listed flexible connector with an I.D. equal to 3/4" pipe must be used. DO NOT USE A DOMESTIC APPLIANCE TYPE GAS FLEXIBLE CONNECTOR. Avoid kinks or sharp bends that could restrict gas flow.

PIPE JOINT COMPOUND OR THREAD SEALANT THAT IS USED SHOULD BE RESISTANT TO ACTION OF LIQUEFIED PETROLEUM GASES.

Turn gas shutoff valve "ON" and immediately check carefully for gas leaks. Do this before attempting to operate the oven.

TEST ALL PIPE JOINTS FOR LEAKS BEFORE OPERATING OVEN. THIS INCLUDES ALL GAS CONNECTIONS THAT MAY HAVE LOOSENED DURING SHIPMENT. USE A RICH SOAP SOLUTION (OR OTHER ACCEPTED LEAK TESTER) AROUND ALL PIPE CONNECTIONS AND ALL OTHER JOINTS. DO NOT USE AN OPEN FLAME. ABSOLUTELY NO LEAKAGE SHOULD OCCUR, OTHERWISE THERE IS A DANGER OF FIRE OR EXPLOSION DEPENDING UPON CONDITIONS. NEVER USE IF LEAKAGE IS DETECTED.

## INSTALLATION

### **Model R85** (Refer to Fig. 2, p. 4)

Uncrate oven and base as near to final location as possible. Remove all packing material and accessories from oven interior. With help from at least two other people, tip the oven slowly on its side. With the oven lying on its side, hold the front leg securely and align the threaded stud on the leg with the nut located at the front corner of the accessible side. Insert the leg into the nut and turn the leg clockwise. Tighten the leg to the oven securely. Rotate the leg counter-clockwise slightly to align the two leg plate holes with the holes on the bottom of the oven. Secure the leg using the provided 3/8" bolts and washers. Repeat the procedure for the rear corner of the side off the ground. Tip the oven up on the secured legs and lean the oven against a wall so that the legs on the remaining side can be attached. Install the remaining two legs using the aforesaid procedure. Tip the oven back down on the newly installed legs and re-tighten all the bolts securely.

A flue detector is supplied in Kit RS1 with the gusset legs. A Draft Hood is also available as Kit RS2, and replaces the flue deflector. Either a flue deflector or a draft hood must be installed on the unit. The flue detector is intended for use when the oven is installed under a properly designed hood. When the oven is directly connected to a vent system, the draft hood must be used.

When the oven is in permanent position, level entire unit by placing a carpenter's level on the oven rack and adjusting the foot on the bottom of each leg so that the oven is level from front to back and side to side.

### **Model R2-85 Series** (Refer to Figs. 4, 5 & 6, p. 6)

Screw the adjustable feet of the legs in all the way. Then tightly screw the complete leg assembly into the mounting holes at each corner of the lower R85 unit. Mount lugs on top of the lower R85 unit, as to center the top unit on the lower one.

Set upper deck unit in place on top of lower deck.

From Kit RD1, locate the flue riser, the flue collector, and the flue deflector. Install the flue collector over the flue outlet on the lower R85 unit. Install the flue riser over the outlet of the horizontal flue collector. Secure in place with self-drilling sheet-metal screws. Install the flue deflector over the flue outlet of the upper R85 unit. This setup is intended for use when the oven is installed under a properly designed hood. **Note:** When the oven is to be directly connected to a vent system, Kit RD2 must be used in conjunction with Kit RD1. Replace the flue deflector with the Draft Hood ensuring that it covers the flue outlet of the upper R85 unit. It must cover the top of the flue riser as well.

When the oven is in permanent position, level entire unit by placing a carpenter's level on the oven rack and adjusting the foot on the bottom of each leg, so that the oven is level from front to back and side to side.

### **GAS CONTROL SYSTEM**—All Models Except with Suffix “EI”

#### **Lighting**

Turn on main gas shutoff valve and electrical service.

IN THE EVENT A GAS ODOR IS DETECTED, SHUT DOWN UNITS AT MAIN SHUTOFF VALVE AND CONTACT THE LOCAL GAS COMPLANY OR GAS SUPPLIER FOR SERVICE.

1. Turn oven burner valve clockwise to “OFF” position.
2. Remove burner compartment access panel below oven doors by pulling bottom panel outward to disengage panel catches.
3. Press and hold red safety pilot in and apply lighted match to pilot burner. After pilot burner ignites, continue to hold red button depressed for 30-45 seconds or until pilot remains burning when button is released.
4. Replace burner compartment access panel.
5. Set thermostat to desired temperature.
6. Turn oven burner valve counterclockwise to “ON” position.
7. Turn on fan. Fan should be on at all times during cooking operation.

#### **Shut Down**

1. Stand By
  - a. Turn oven burner valve to “OFF” position.
  - b. Turn off fan.
2. Complete
  - a. Turn all gas valves to “OFF” position
  - b. Turn fan off.
  - c. Turn electrical service off of disconnect electrical supply cord from wall receptacle.

#### **Relighting**

1. Turn oven burner valve to “OFF” position.
2. Wait five (5) minutes then follow “Lighting” instructions.

## OPERATION

### **GAS CONTROL SYSTEM**—Models With Suffix “EI” (Equipped with electronic ignition system)

#### Operation

1. Turn manual valve to “ON” position.
2. Set thermostat to desired temperature.
3. Push toggle of Start/Reset switch to “UP” position and release. The electronic pilot ignition control will automatically light the pilot and burner each time the thermostat calls for heat.
4. If pilot fails to ignite within 30 seconds, a complete shut down of the ignition system will occur. To initiate a re-ignition, wait at least 30 seconds, push toggle of Start/Reset switch up, then release.

#### Shut Down

1. Turn manual valve to “OFF” position.
2. Turn thermostat to lowest setting.

#### CAUTION

DO NOT ATTEMPT TO LIGHT THE PILOT MANUALLY WITH A MATCH. THIS COULD RESULT IN THE MAIN VALVE BEING ENERGIZED IMMEDIATELY.

#### CONTROLS

##### Standard Models—Models With Suffix “AE, AG, ZE, ZG”

1. “LIGHT-OFF” switch controls the oven interior lights.
2. “FAN-OFF-COOL” switch controls the fan operation. It must be on to obtain satisfactory performance.
  - a. The center position is “OFF”
  - b. Depressing “FAN” side of switch causes the motor to run continuously when doors are closed. When doors are opened, fan will stop. This position is for cooking.
  - c. Depressing “COOL” side of switch will result in continuous blower operation even with doors open. This position is intended for cooling the oven at the end of work period or lowering oven temperature.

NOTE: When cooling oven down, the burner valve should be turned off to prevent burner operation.

3. The thermostat controls the oven temperature. The “BURNER” indicator light remains lit until desired oven temperature is reached.
4. The timer is only a time reminder. It has no control over the oven.

## Models With Suffix “EI”

Same as “Standard Models” above except for “START/RESET” switch for the electronic ignition system. Depress switch momentarily at the start of the work period.

## INTERMITTENT FAN OPERATION (IFO) CONTROLS (Optional)

The IFO fan control cycles the fan ON for 30 seconds and OFF for 30 seconds during a variable time of 0.1 to 10 minutes of the cook period.

### IFO Control

1. **START SWITCH (MOMENTARY)**  
Activated the IFO cycle.
2. **CYCLE TIMER (0.1 TO 10 MIN.)**  
Controls the duration of the IFO cycle.
3. **INDICATOR LIGHT (AMBER)**  
When lighted, indicates the oven is in the IFO cycle.

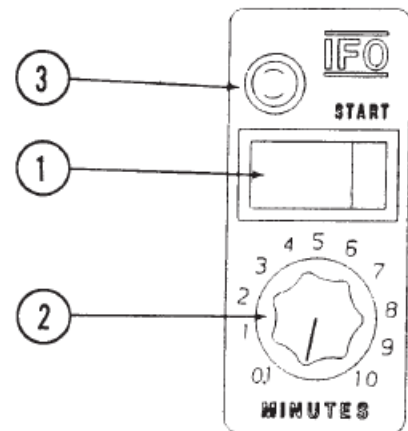

### IFO Operation

To set the IFO controls, first set the “Cycle Timer” knob for the desired IFO time period. Once the oven has reached temperature, load the product to be baked and close the door. Immediately set and start the standard timer for the overall cook cycle. Next, push the “Start” switch on the IFO control. The amber indicator light will come on, the fan will stop, and then cycle on and off every 30 seconds until the set time has expired. The amber light will remain on continuously until the set time has expired.

Once the amber light is on, additional pushing of the “Start” switch will have no effect. Also the “Cycle Timer” knob does not count down during the IFO cycle, but remains at its setting for repeat cycle if desired.

To cancel the IFO cycle once started, simply rotate the “Cycle Timer” knob counterclockwise until it stops.

Once started, the IFO time period can be readjusted by simply repositioning the “Cycle Timer” knob. If the knob is turned counterclockwise to a setting that is less than the current time expired during the cycle, the cycle will be terminated. To restart a cycle, simply push the “Start” switch.

If it is necessary to open the door during the IFO cycle, the fan will shut off if it is running. The IFO timed cycle will continue uninterrupted, however, until the set time has expired. If there is a loss of power during the cycle, it will be terminated.

## OPERATION

### MOIST AIR CONTROLS & OPERATION (optional)

#### Moist Air (Steam) Option

The Moist Air option permits the operator to add steam to the oven chamber during the cooking cycle. This is desirable during baking operations for crusting purposes or to maximize growth during the initial bake period. It can also be useful for products requiring more moisture during the cook cycle.

#### Moist Air Components

The Moist Air option includes a water shut-off valve, water regulator/filter assembly, solenoid valve, steel piping, spray nozzle, steam pan and Moist Air control cluster. During operation, activating controls causes the solenoid valve to open and heated water to be sprayed into the hot oven chamber where it is turned into steam. The steam pan converts any excess spray to steam and controls residue accumulation.

### INSTALLATION

#### ATTENTION!

The Moist Air option requires a connection to good quality water that is low in total dissolved solids and free of particulate matter. A water purification/treatment system must be installed if harsh water conditions exist. If in doubt, have your water supply checked by a water treatment company.

The water regulator filter assembly with shut-off valve (supplied with the Moist Air option) should be wall mounted near the oven so that the four foot removable hose will reach the water connection on the back of the oven. A permanent 1/2" cold water connection should be made at the shut-off valve. This filter is meant to remove final traces of taint, odor, rust, and scale when used with good quality water or a water purification/treatment system. It is not a substitute for a water treatment if harsh water conditions exist.

All other normal installation requirements for a Vectaire convection oven, as described in the "Installation" section of the main Vectaire manual, should be followed.

### OPERATION

The Moist Air control regulates the spray of water that created steam in the oven chamber. The duration of the water spray can be varied from .3 to 30 MOIST AIR seconds. The spray is initiated by depressing the start switch.

To set the Moist Air controls, first set the "Cycle Timer" knob for the desired time period. Once the oven has reached temperature, load the product to be baked and close the door. Immediately set and start the standard timer for the overall cook cycle. Next, push the "Start" switch on the Moist Air control. The blue indicator light will come on, and remain on continuously until the set time has expired. Steam is being generated in the oven when the light is on.

Once the blue light is on, additional pushing of the "Start" switch will have no effect. The "Cycle Timer" knob does not count down, but remains at its setting for repeat cycle if desired.

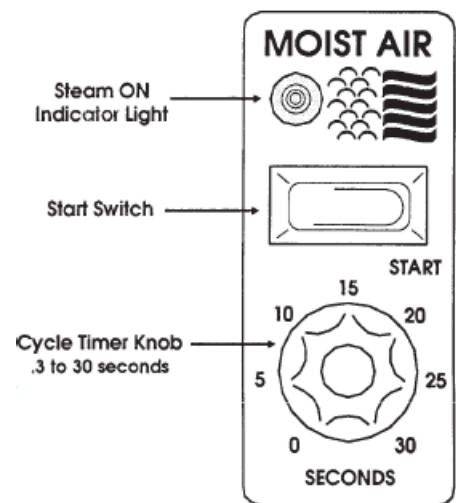

## CAUTION

Never attempt to open the oven doors while the Moist Air indicator light is on, and use caution for at least 5 minutes after the light has gone out. The hot, moist air resulting from the steam generation could cause serious burns.

Best performance from the Moist Air option is realized at temperatures of 300°F and above. The Moist Air option is not recommended for use at temperatures below 250°F, and a low-limit control will not permit activation at temperatures below about 200°F. A full preheat of the oven (1 hour) is necessary before use. Once at temperature, as many steam cycles can be initiated as desired.

An oven vent control is conveniently located at the top of the control panel. Positioning the lever all the way to the left closes the vent; to the right opens the vent. For best results, introduce steam into the oven with the vent closed. After two or three minutes, open the vent to allow the steam to escape and leave open for the remainder of the bake.

## MAINTENANCE

Additional maintenance is required with the Moist Air option to insure trouble-free operation.

The filter cartridge should be replaced every 4-6 months. This can be easily done by closing the water valve, then loosening the thumb screw at the bottom of the filter bracket.

The spray nozzle is located inside the oven behind the fan baffle. With the fan baffle removed, the spray nozzle can be removed and disassembled for cleaning. The fine mesh monel screen should be carefully cleaned with air pressure to remove debris and scale deposits. The grooved distributors inside the nozzle housing should be removed and both pieces checked with a wire to be certain they are free from any build-up of scale or sediment. Reassemble the nozzle and install. This should be done every 1-3 months depending on water conditions.

The oven interior should be cleaned daily with warm soapy water to discourage the build-up of deposits. The use of an abrasive is not recommended.

## SERVICE

If the Moist Air option requires service or becomes inoperative, contact the local Authorized Service Agency.

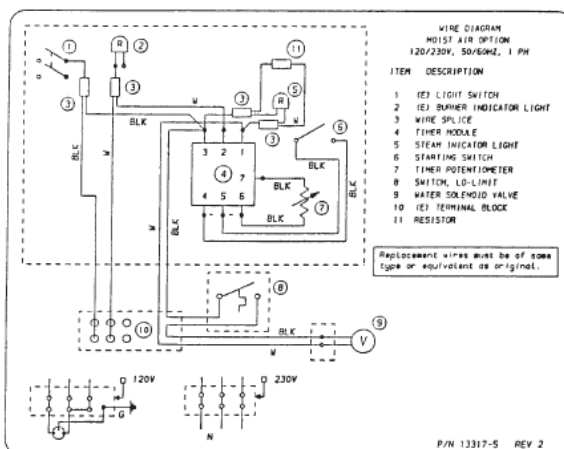

## COOKING HINTS

### USING A CONVECTION OVEN

The convection oven is a different type of oven which offers many features and advantages to the food service operation. The operation of the oven is not difficult to understand or control.

The convection oven is the sealed type whereby the combustion products are separated from the air inside the oven. The heat is transferred through the oven surface into the cavity. The air inside the oven is continuously recirculated over the heat source and the product.

The moving air strips away the insulating layer of moisture on the products allowing heat to penetrate faster for quicker baking and roasting. Due to these differences in the methods of cooking in a convection oven, procedures and techniques may require some modification for successful results. A general rule which will assist in better operation, is cooking time will be less and temperatures should be 25 to 75 degrees lower than those called for in standard recipes.

**For convection oven cooking, reduce temperature 25 to 75 degrees from those given in standard recipes.**

Type of Food	Reduction in Temperature	Reduction in Time
<b>Baked Products</b>		
Cookies	25°	1/4 to 1/3
Cakes & Quick Bread	50°	1/4 to 1/3
Yeast Products	75°	1/4 to 1/3
Casseroles	25°	1/4 to 1/2

### GUIDE TO BAKING TIMES AND TEMPERATURES

These times and temperatures were especially prepared and tested for use in a **Vectaire** convection oven. Times, temperatures, and moisture contents may vary in other convection ovens. The suggested times and temperatures may vary considerably from those shown. They are affected by weight of load, recipe, type of pan, size of portion, and calibration of thermostat. Differences in quality and age of meats and fowl, and quantities of shortening, milk, fat, and other ingredients in baked goods affect both cooking times and temperatures.

These charts have been compiled carefully. However, they are only guides. You may want to cook certain foods a little more or a little less according to your preference and your recipe. Also, types and sizes of pans influence baking time and temperatures.

It is absolutely necessary to use lower temperatures. As a guide, set oven temperatures 25-75 degrees lower than called for in your recipes using non-convection ovens.

Use this chart as a guide to develop your own cooking techniques.



**Guide to Time and Temperature**

<i>Product</i>	<i>Temperatures (Degrees F)</i>	<i>Time</i>	<i>Number of Racks Used</i>
<b><i>Bread, Bakery</i></b>			
Bread (24-1lb. loaves)	340	30 min.	3
Hamburger Rolls	300	15 min.	5
Corn Bread (Northern)	335	25 min.	5
Corn Bread (Southern)	375	15-20 min.	5
Yeast Rolls	325	25 min.	5
Baking Soda Biscuits	400	6 min.	5
Cinnamon Buns	335	20 min.	5
Danish	335	12 min.	5
Brownies	300	18 min.	5
Cream Puffs	350	20-25 min.	5
Sugar Cookies	300	15 min.	5
Chocolate Chip Cookies	275	8-10 min.	4
Sheet Cakes (5lb./1" pans)	325	16-18 min.	5
Chocolate Cake	325	20 min.	5
Angel Food Cake	250	25-30 min.	3
Fruit Cakes	275	70 min.	3
Pie Shells	350	12 min.	5
Frozen Berry Pies (20 oz.)	350	35 min.	5 (30 Pies)
Frozen Berry Pies (46 oz.)	350	45-50 min.	5 (20 Pies)
Fruit Cobbler	375	25 min.	5
Fresh Apple Pies (20 oz.)	350	25-30 min.	5 (30 Pies)
Pumpkin Pies	275	30-35 min.	5
Custard Pies	250	25-30 min.	5
Meringue Pies	350	4 min.	5
Apple Turnovers	350	20 min.	5
Fruit Crisp	300	25 min.	5
Pizza (13")	475	6 min.	5
<b><i>Meat, Poultry, Fish</i></b>			
Hamburger Patties	400	8 min.	9
Meat Loaf	325	40-45 min.	3
Prime Rib (20 lbs.)	250	2-1/2 hrs.	2
Rolled Beef Roast (12-15 lbs.)	250	2-1/2 hrs.	3
Steamship Round (80 lbs.)	275	2-3/4 hrs.	2
Steaks - New York	450	7 min.	5
Steaks - Salisbury	300	20 min.	5
Boned Veal Roast (15 lbs.)	300	3 hrs.	2
Stuffed Pork Chops	375	25-30 min.	5
Lamb Chops (Sm. Loin)	400	6 min.	5
Fish Sticks	335	16-18 min.	9
Halibut Steaks (Frozen)	350	20 min.	5
Lobster Tails (Frozen)	425	7 min.	5
Stuffed Lobster	400	6-7 min.	3
Stuffed Shrimp	400	6-7 min.	5
Chicken Breast & Thigh	325	40 min.	5
Chicken (2-1/2 lbs. Quartered)	325	30 min.	5
Turkey, Rolled (18 lbs.)	310	3-1/2 hrs.	3
Chicken - Turkey Pot Pies	400	30-35 min.	5
<b><i>Miscellaneous</i></b>			
Idaho Potatoes (120 ct.)	400	50 min.	5
Lasagna	250	90 min.	3
Stuffed Peppers	350	15-20 min.	3
Hot Dogs	300	10-15 min.	5
Meltd Cheese Sandwiches	400	8 min.	9
Macaroni and Cheese	350	15-20 min.	5

## COOKING HINTS

### Suggestions

- Avoid recipes that would not be satisfactory in a regular conventional oven.
- Times and temperatures will vary slightly with maximum to minimum oven loads.
- Stagger pans in ovens as much as possible to allow the free flow of air.
- Pans may be tightly sealed with sheets of aluminum foil. Do not let the foil touch the food.
- Convection ovens usually save 1/4 to 1/3 of the total cooking time. Check product at one-half of the cooking time of the recipe. Add additional time as needed.
- For most products, use a maximum of 5 racks for optimum results.
- For less browning, lower temperature; for more browning, increase temperature. If product cooks too quickly around the edges, lower temperature.
- Level pans bake more evenly than warped pans.
- Filling pans too full causes uneven baking.
- When using frozen entrées, refrigerator-thaw for best results, and cover during cooking.
- Load and unload food quickly. Close oven doors promptly.
- The type of pans used affect baking time and results. A shiny pan reflects heat, a dark dull pan absorbs heat.
- When baking fruit pies, use a baking pan on the rack and set pie tins on top of pan. This will result in evenly cooked bottoms and also catch spillovers.

### Baking Difficulties & Problem Causes

Good baking is a delicate operation and many operational factors enter into it.

Pans which warp or buckle under heat always result in poor bakes. Pans with highly polished reflecting surfaces generally cause light colored bottom or sides. Muffin tin cups should all rest on a flat surface, otherwise light or underdone bottoms will result. Pie tins that are pocked or warped will give undesirable results.

Overproofing, working dough in too high of a room temperature, overworking pastry dough, absence of or improper scaling, cutting and uneven loading of pans are sure ways of getting uneven baking.

“HIT OR MISS” recipe mixing: Guess work in the matter of quality and quantity of ingredients frequently results in poor bakes.

The following are some baking problems and their probable causes:

### **Goods Pulled to Rear of Oven**

- Oven not level. Pitched to rear causes dough to run to rear.
- Pans too full. Excess will pull over back toward fan.
- Batter has too high a percentage of liquid.

### **Uneven Bakes**

- Insufficient heat input.
- Warped pans.
- Warped oven racks.
- Uneven loading of pan or pans.
- Fan off.
- Oven not level causing dough to run to side or rear of pan.

### **Spotty Pie Bottoms/Bread**

- Overworked pastry/dough.

### **Burned Goods, Cripples**

- Incorrect temperature.
- Thermostat out of calibration.
- Left in too long.
- Improper scaling.

### **Dried Out Goods**

- Too low temperature.
- In oven too long.
- Improper mix.

### **Alternately Good and Poor Results**

- Fan off and on.
- Improper scaling and control of ingredients.

### **Tops Dark, Center Not Done**

- Too high temperature.

### **Side Burning**

- Oven not level.
- Uneven loading.

## COOKING HINTS

---

### **Lack of Uniformity—Same Pan**

- Uneven loading in pan. (See uneven bakes).
- Faulty pans.

### **Lack of Spring**

- Overproofing.
- Incorrect temperature.

### **Cracked Cakes**

- Too high temperature
- Too fast cooling.

### **Underdone Pie Bottoms** (Advisable to bake on cookie sheet)

- Pastry too rich.
- Pastry too thick.
- Warped pie tins. (When used on cookie sheet)

### **Heavily Colored Pie Rims**

- Air bubbles enclosed in pastry when crimped.

### **Uneven Baked Cookies**

- Not scaled properly.
- Pans warped.

**CAUTION**  
**DISCONNECT POWER BEFORE CLEANING OR SERVICING. EACH OVEN SECTION HAS  
A SEPARATE ELECTRICAL SUPPLY CONNECTION.**

### **General Cleaning**

The complete oven should be given a periodic cleaning. Lint and grease suspended in the air tend to collect in air passages.

Remove burner compartments access panel and clean any dirt and lint from burner primary air opening and all air passages and openings. Clean lint and grease accumulation from motor air openings.

### **Exterior**

PAINTED SURFACE: Allow equipment to cool after use and wash with a mild detergent or soap solution. Dry thoroughly with a dry cloth.

STAINLESS STEEL SURFACES: Follow instructions in Stainless Steel section.

### **Oven Interior**

STANDARD FINISH (Porcelain Enamel): Frequent cleaning is required. Spillovers should be cleaned as soon as possible to prevent carbonizing and a burnt-on condition. Wait until oven is cool for complete cleaning. Usually a soap or detergent solution is strong enough to remove any grease residue. A mild abrasive nylon cleaning pad may be used for stubborn spillovers or stains. Non-caustic commercial oven cleaners may be used, but do not allow cleaners to come in contact with the temperature probe. Wipe off all oven cleaner residue.

The racks and rack guides are readily removable for cleaning. Loosen retainer clips to disengage rack guides for removal.

Foreign matter may collect on the fan blades and reduce circulation. When this becomes apparent, remove the fan baffle plate which is secured by 4 thumb screws and pull plate up and forward. The use a stiff brush on each fan blade.

CONTINUOUS CLEAN FINISH: It is readily identified by its dark brown and white speckled finish. This coating is endowed with a unique cleaning ability that causes food and grease spatters to gradually clean away automatically when exposed to normal oven temperatures.

Each day, after baking and roasting operations have been completed, empty the oven. Then turn the temperature control up to high heat. This high heat will speed up the cleaning action and reduce the time required to clean the oven effectively. The cleaning time necessary will depend up on the "soil" condition the oven. As a general rule, allow from 45 to 60 minutes.

When the oven appears soiled due to heavy staining, we suggest preheating the empty oven each day for one or two hours for most effective results. Also, ordinary household ammonia has proved an effective method for removing baked-on build-up, and in keeping the microscopic pores of the coating open and free to perform its cleaning action. Thus, an occasional light swabbing with household ammonia while oven is at room temperature can prove to be extremely beneficial.

## MAINTENANCE

Excessive spillage or crust which is allowed to build up on oven interior surfaces will seriously retard the continuous cleaning action. It should be wiped away as soon as possible with a damp cloth.

Although the oven may appear clean, we recommend operating the oven at high heat for approximately two hours once every month. This will prevent build-up of solids in hard-to-see places or in the pores of the coating. Caution: Never use abrasives, powders, harsh liquids, caustics, or dyes as they may leave a film or residue that will clog the pores of the special coating, and retard the cleaning action.

Certain types of food may leave a stain that is slow to fade. These include flour-milk mixtures, sugar, macaroni and cheese, cream sauces, and blood. It may take a slightly longer time for the continuous cleaning action to clean this type of stain. Accelerate removal by using household ammonia while oven is at room temperature.

If excessive soils or spillovers have become carbonized, remove the charred portion with a hard nylon brush. (Do not use steel or other metallic brushed or scouring pads). For any stubborn stain or "varnish" film, apply a good grade paste oven cleaner in the following manner:

- (1) With the oven at room temperature, apply paste over the spill.
- (2) Allow to stand for 10-15 minutes (read instructions on label of product); then wipe up spill.
- (3) Reapply if not entirely removed (any film remaining over top of material will prevent self-cleaning action).
- (4) Remove loosened particles with a damp cloth. Note: Steam may be used where it is available. It is not harmful to the special coating. Always be sure to wipe up any excess water.

**STAINLESS STEEL:** To remove normal dirt, grease, or product residue from stainless steel, use ordinary soap and water (with or without detergent) applied with a sponge or cloth. Dry thoroughly with a clean cloth.

To remove grease and food splatter, or condensed vapors that have baked on the equipment, apply cleanser to a damp cloth or sponge and rub cleanser on the metal in the direction of the polished lines on the metal. Rubbing cleanser as gently as possible in the direction of the polished lines will not mar the finish of the stainless steel. **NEVER RUB WITH A CIRCULAR MOTION.** Soil and burnt deposits which do not respond to the above procedure can usually be removed by rubbing the surface with SCOTCH-BRITE scouring pads or STAINLESS scouring pads. **DO NOT USE ORDINARY STEEL WOOL** as any particles left on the surface will rust and further spoil the appearance of the finish. **NEVER USE A WIRE BRUSH, STEEL SCOURING PADS (EXCEPT STAINLESS, SCRAPER, FILE, OR OTHER STEEL TOOLS.** Surfaces which are marred collect dirt more rapidly and become more difficult to clean. Marring also increases the possibility of corrosive attack.

**TO REMOVE HEAT TINT:** Darkened areas sometimes appear on stainless steel surfaces where the area has been subjected to excessive heat. These darkened areas are caused by thickening of the protective surface of the stainless steel and are not harmful. Heat tint can usually be removed by the foregoing, but tint which does not respond to this procedure calls for a vigorous scouring in the direction of the polish lines, using SCOTCH-BRITE scouring pads or a STAINLESS scouring pad in combination with a powdered cleanser. Heat tint action may be lessened by not applying or by reducing heat to equipment during slack periods.

### **Electric Fan Motor**

The customized electric fan motor has been specially manufactured for this application and should under normal conditions give years of trouble-free service.

The unit is supplied with permanently lubricated sealed bearings which require no additional lubrication. A high temperature grease has also been used to increase bearing life and should only be replaced by an authorized service station.

The motor is equipped with a built-in thermal overload protector which will warn of any over heating.

The motor is of an open drip-proof type construction, and as such, care should be given to see that the ventilation openings remain clear.

If problems do develop with the motor, contact your nearest authorized service station, do not attempt repairs yourself. This is a special piece of equipment and should only be serviced by competent persons familiar with the construction.

**CAUTION:**  
CARE SHOULD BE USED WHEN WASHING DOWN EQUIPMENT TO KEEP WATER  
AND CLEANING SOLUTIONS OUT OF THE MOTOR OR DAMAGE WILL OCCUR.

## ADJUSTMENT

### Main Burner

While your oven has been factory adjusted, it sometimes happens that the actual operating conditions are different. Therefore, it may be necessary to make a field adjustment to secure satisfactory performance. The air adjustment should give a medium sharp flame without lifting or flashback. Air shutter is adjusted by loosening thumb screw and sliding air shutter left or right. Tighten thumb screw after adjustment. The R85 sheet metal burner has two air shutters, one for each burner tube.

The orifice on the manifold is the fixed type, sized for the respective gas supply.

### Door Adjustment

Procedure:

1. Right hand door on oven does not close when left hand door closes. Loosen turnbuckle "1" and tighten turnbuckle "2".
2. Left hand door on oven does not close when right hand door closes. Loosen turnbuckle "2" and tighten turnbuckle "1".

**Note:** Half turn on turnbuckle equals approximately 1/2" adjustment. When through with adjustment, both turnbuckles should be left flat so as to clear front fire box panel.

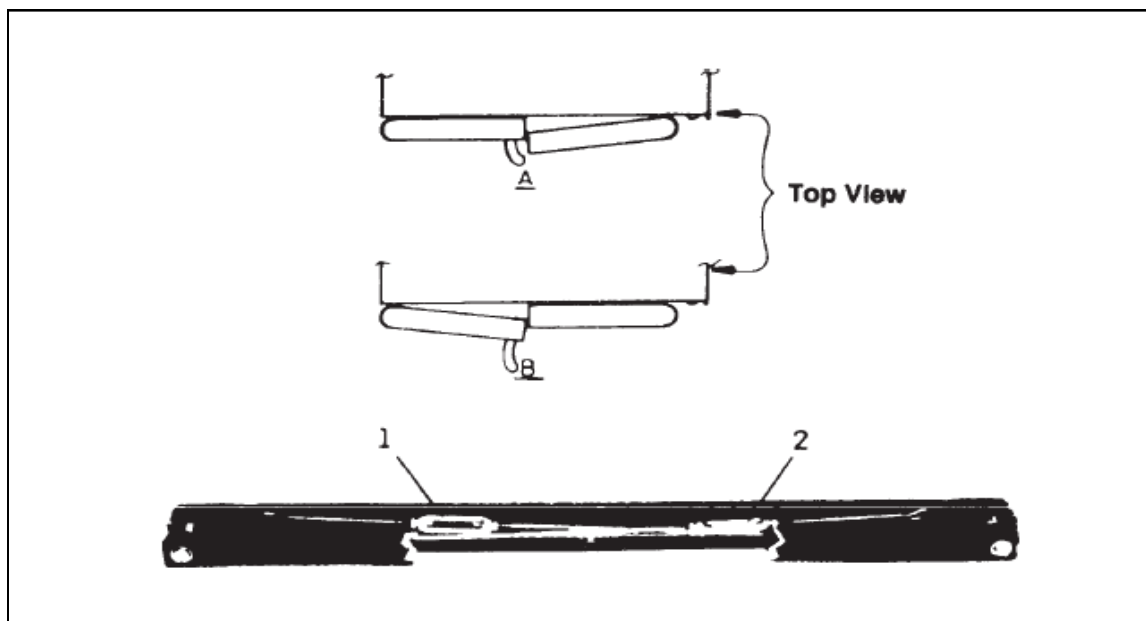



## DOOR SWITCH ADJUSTMENT—Models With Suffix “A”

Door switch can only be adjusted by bending switch lever with pliers.

Procedure:

1. Remove upper front trim panel for access to switch.
2. Bend switch lever with pliers so that fan will stop when door is opened between 9 and 10 inches.

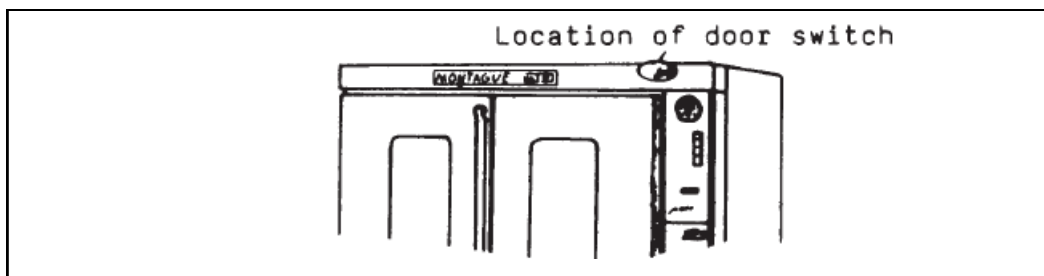

## DOOR SWITCH ADJUSTMENT—Models with suffix “Z”

Before adjusting door switch, make sure fan switch is in “fan” instead of “cool” position. Electrical circuit in “cool” position bypasses door switch.

Procedure:

1. Disconnect electrical power supply.
2. Remove upper and lower control panels.
3. Loosen top locknut on door switch.
4. Raise or lower bottom locknut so that when the door is closed, the plunger on the switch is depressed approximately 1/8”.
5. Tighten top locknut.
6. Replace both control panels.

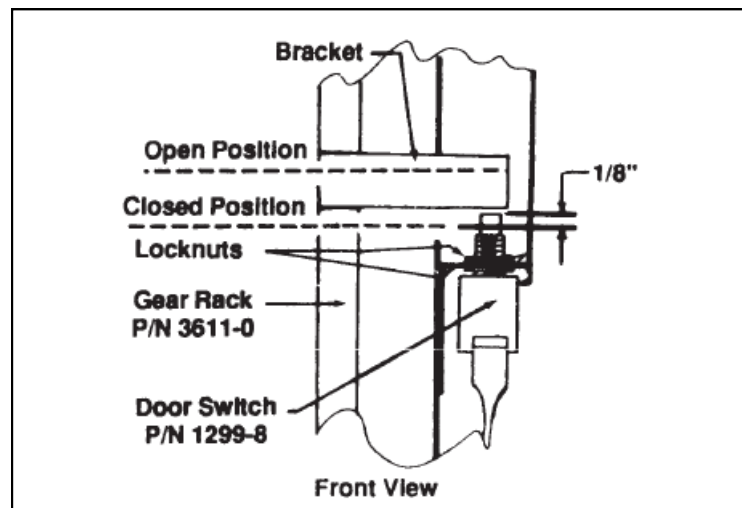

## SERVICE

WHEN SERVICE IS NEEDED, CONTACT A LOCAL SERVICE COMPANY, DEALER, OR FACTORY TO PERFORM MECHANICAL MAINTENANCE AND REPAIRS. THESE INSTRUCTIONS ARE INTENDED FOR USE BY COMPETENT SERVICE PERSONNEL.

**CAUTION:**  
DISCONNECT POWER BEFORE DOING ANY SERVICE WORK. EACH OVEN SECTION HAS A SEPARATE ELECTRICAL SUPPLY CONNECTION. TURN OFF GAS SUPPLY WHEN SERVICING GAS CONTROL SYSTEM.

### THERMOSTAT ADJUSTMENT

The calibration of the thermostat should not be changed until sufficient experience with cooking results has proved that the thermostat is not maintaining proper oven temperature. Before any recalibration is attempted, the oven temperature should be checked using a good grade thermometer.

#### GAS THERMOSTAT—Models with suffix “G”

The Model FDO Robertshaw is a combination Snap-Throttle Thermostat. When the dial is set at a temperature, the thermostat will open wide allowing maximum flame at the burner. As the temperature begins to rise and reach the temperature setting, the thermostat begins to throttle the gas, cutting down the burner flame to the amount of gas needed to hold the oven at the set temperature. If the oven is empty or very lightly loaded, the minimum flame of the burner will continue to rise. When this happens, the thermostat snaps the minimum flame off. As the temperature drops, the minimum flame will snap on. It is possible to operate the oven at a low temperature and at the same time give you the advantage of a throttling type thermostat.

#### By-Pass (Minimum Burner Flame)

THIS ADJUSTMENT MUST BE CHECKED AT THE TIME APPLIANCE IS INSTALLED.

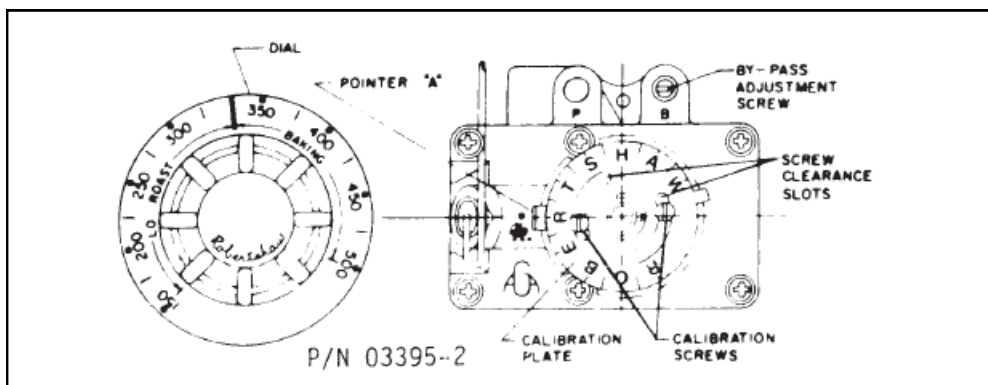

TO ADJUST BY-PASS (Be sure pilot flame is ignited):

1. With oven cold, turn dial counterclockwise slowly from “Low-Stop” until by-pass seat just snaps on.
2. Remove dial.
3. With a screwdriver, turn “By-Pass Adjustment Screw” (see sketch) counterclockwise to increase the by-pass flame to clockwise to decrease it until flame over entire burner is approximately 1/4” high.
4. Replace dial.

**CAUTION:**

While making this adjustment, if the oven should become heated while the dial is set at a low range (below 350), the bypass flame will shut off completely. If this occurs, turn dial counterclockwise slowly until by-pass gas valve snaps on. Then check by-pass adjustment as stated above.

Thermostat Calibration Check:

1. Place the thermocouple of test instrument or thermometer in the middle of the oven, or medium to be tested.
2. Light the main burner.
3. Turn dial so 400 lines up with “Pointer A” indicator mark.
4. Allow the oven to heat until flame cuts down to by-pass. After sufficient time, check temperature. If the temperature does not read within 15 degrees of the dial setting, recalibrate as follows:
5. Pull dial straight off without turning.
6. Hold calibration plate and loosen the two calibration lock screws until the plate can be moved independently of the control.
7. Turn calibration plate counterclockwise if the test reading is higher than the dial setting, or clockwise if the reading is lower than the dial setting. The temperature range between each mark is 25°F (Between each letter is 50°F).

NOTE: If the adjustment is prevented by the two loosened calibration lock screws being in contact with the ends of the screw clearance slots in the calibration plate, remove the screws after turning the calibration plate to the proper location, reassemble screws in the other tapped holes designed for them.

8. Replace dial.

**ELECTRIC THERMOSTAT—Models with Suffix “E” & “EI”**

1. Place a pyrometer thermometer or a reliable mercury oven type thermometer at the center of the middle rack.
2. Turn the dial of the cook thermostat to a temperature setting of 350°F.
3. The red cook indicating light will switch from “ON” to “READY” when the thermostat turns off the burner.
4. Allow three (3) such cycles for the temperature to stabilize.
5. Read the pyrometer or thermometer immediately after the “READY” light comes on for the third time and again immediately after the “READY” light comes on the next time.
6. If the average readings and the dial setting vary by more than 15°F, recalibrate by following the instructions outlined below.

## SERVICE

To Recalibrate

1. Remove dial from dial shaft "B".
2. Turn screw "A" clockwise to decrease and counterclockwise to increase the temperature.
3. 1/4 turn changes the temperature 35°F.
4. Replace dial on dial shaft.
5. After a calibration is made, set the dial at 350°F and recheck the oven temperature using the method above, outlined by items 1 thru 6.

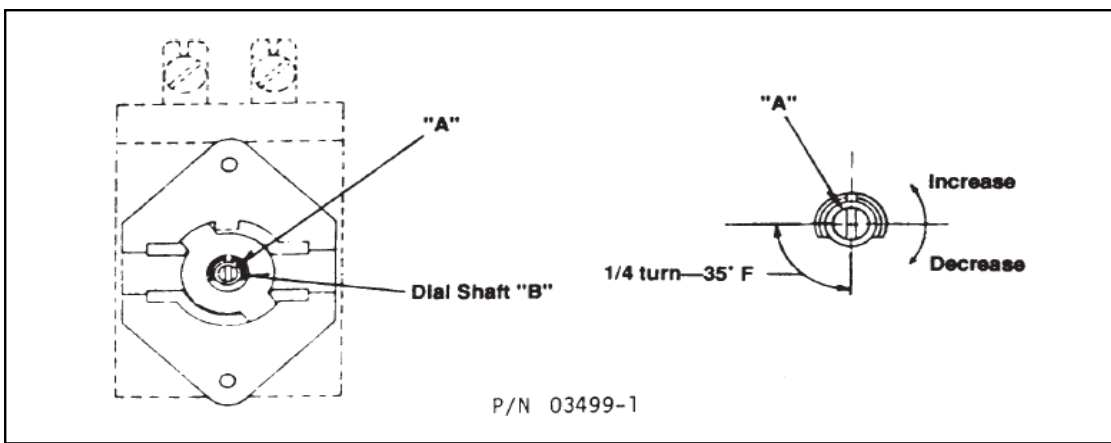

### REPLACEMENT OF OVEN INTERIOR LIGHT BULBS

Disconnect electrical power to oven before servicing. Remove six thumb screws located at the top and bottom and middle of the fan baffle and pull the panel forward to expose light sockets.

**REMOVAL OF MAIN BURNER AND PILOT BURNER**

1. Remove burner box panel for access.
2. Turn off gas supply to oven. Remove single screw at front of burner on the left side.
3. Slide main burner to the left until venturi clears orifice and pull main burner and pilot burner out far enough for access to the pilot burner mounting screws.
4. Remove mounting screws from pilot burner and pull main burner the remainder of the way out.

NOTE: Special attention should be given to the condition of burner baffle (P/N 04344-3). Due to the high input rating of this burner, after a period of time, the baffle will burn out. The burner baffle should be replaced before the flame does any damage to the burner box top plate located above the baffle.

**PILOT SERVICE IN THE EVENT OF PILOT FLAME FAILURE**

1. If pilot flame burns yellow, clean pilot orifice and pilot burner to insure a steady blue flame. The orifice can be cleaned by washing in a solvent and/or blowing out with air.
2. Flame must surround the thermocouple tip for approximately 1/2 inch

THERMOCOUPLE OUTPUT	
OPEN CIRCUIT MV RANGE	
NORMAL 25-35	NOT LESS THAN 17

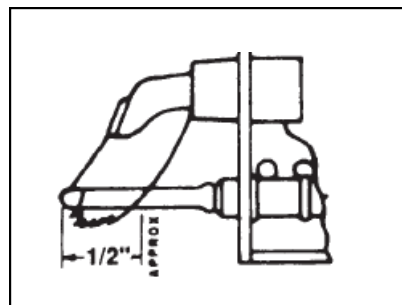

**SAFETY PILOT VALVE**

Model H15HQ-5 BASO is an automatic 100% safety pilot which provides complete gas shut off in the event of pilot failure. The safety valve is half closed by spring pressure. When red button is pushed by hand, gas flows to pilot. Pilot heats thermocouple creating a very small amount of electricity. This energizes a magnetic coil under red button and holds valve open, permitting gas to flow to main burner and pilot without holding pressure on red button. In the event of pilot failure, the flow of electricity will stop and spring will stop flow of gas to both pilot and main burner.

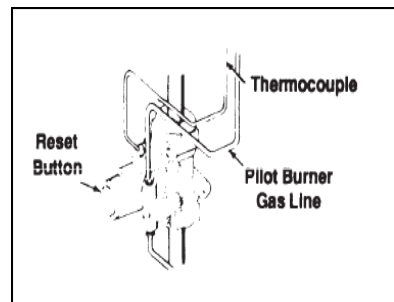

### COMBINATION SAFETY PILOT VALVE & AUTOMATIC GAS VALVE

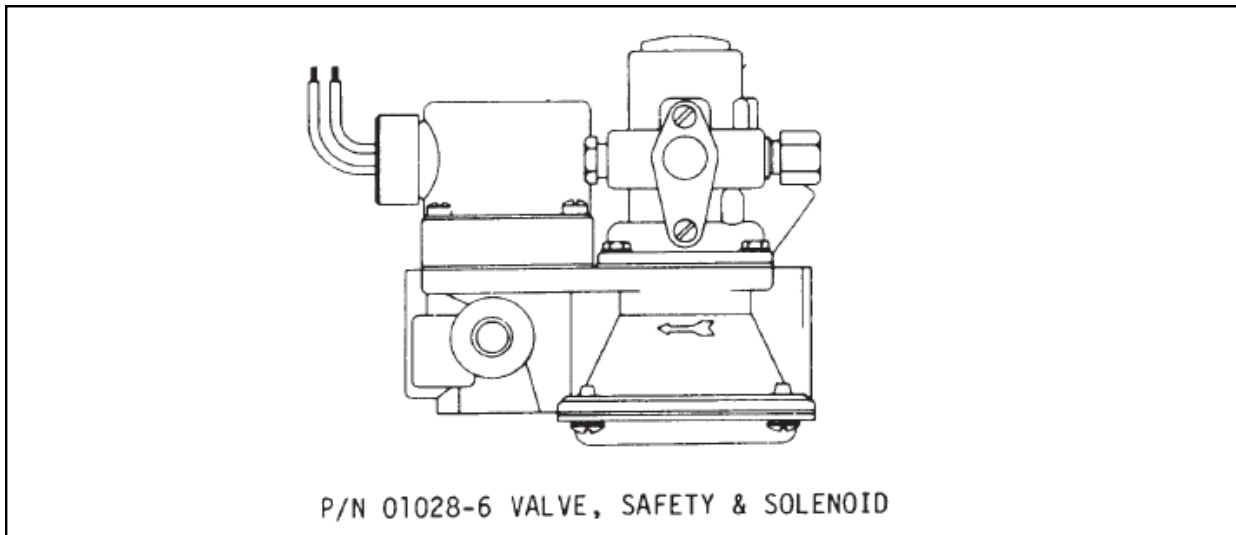

#### Safety Pilot Valve Section

The 100% safety shutoff valve operates from millivoltage produced by a thermocouple properly heated by the pilot flame. In the event of a low, unstable pilot flame or outage, the safety valve provides complete gas shutoff. The safety valve is held closed by spring pressure. When red button is depressed by hand, gas flows to pilot. The pilot flame heats the thermocouple creating a small amount of electricity. This energizes the magnetic coil under red button and holds valve open as long as thermocouple is heated, permitting gas to flow to main burner and pilot. In event of pilot failure, the flow of electricity will stop and spring pressure will close valve shutting off flow of gas to both pilot and main burner.

**CHECKOUT PROCEDURE**  
BEFORE LEAVING THE INSTALLATION, A COMPLETE OPERATING CYCLE SHOULD BE OBSERVED TO SEE THAT ALL COMPONENTS ARE FUNCTIONING PROPERLY.

**GAS PRESSURE REGULATOR**

**WARNING**  
NO UNTRAINED PERSON SHOULD ATTEMPT TO MAINTAIN OT SERVICE THE GAS PRESSURE REGULATOR

**REMOVAL OF BURNER BOX FRONT AND BURNER BAFFLE**

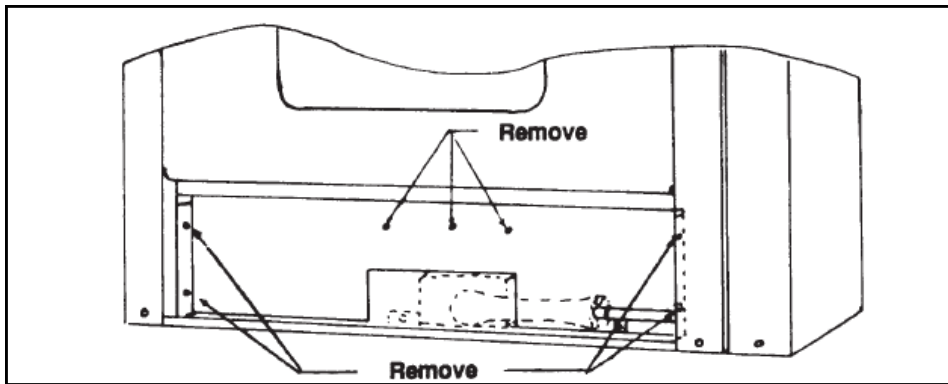

1. Remove Burner Box Panel.
2. Remove oven burner, pilot burner and thermocouple.
3. Remove 7 screws as shown, tilt top of burner box front forward and pull out to clear orifice and manifold.
4. Pull burner baffle (P/N 04344-3 or [34904-6](#)). To replace, reverse above procedure.

**REMOVAL OF MOTOR AND FAN ASSEMBLY**

**DISCONNECT ELECTRICAL POWER TO OVEN(S) BEFORE SERVICING.**

1. Remove six (6) screws at bottom, top and middle of fan baffle and pull forward.
2. Remove the ten (10) 1/4" bolts holding Motor Mount Plate in back of oven.

## SERVICE

3. Pull plate forward 1-1/4" to 1-1/2" so that motor flange clears the 10" cut out in back of oven. Then let motor drop and rest on frame. (The first time this is done, the 1/8" thick rectangular insulation pad between motor and oven back will have to be forced to fit round 10" hole) Pull motor through hole and rest on oven bottom. Reach behind plate and remove top of electrical box mounted on motor. Mark or identify wires for reconnection. Disconnect wire and remove flex from motor. Motor, panel and fan may then be removed from oven.
4. Remove two Allen screws from fan hub and pull off fan using wheel puller. A flange on hub is provided so a wheel puller can be used.
5. Remove four hold-down nuts at motor mounting and remove motor. **IMPORTANT:** When reinstalling motor, check alignment so that fan will not come into contact with plate or fan baffle. Check wiring for proper voltage connection.

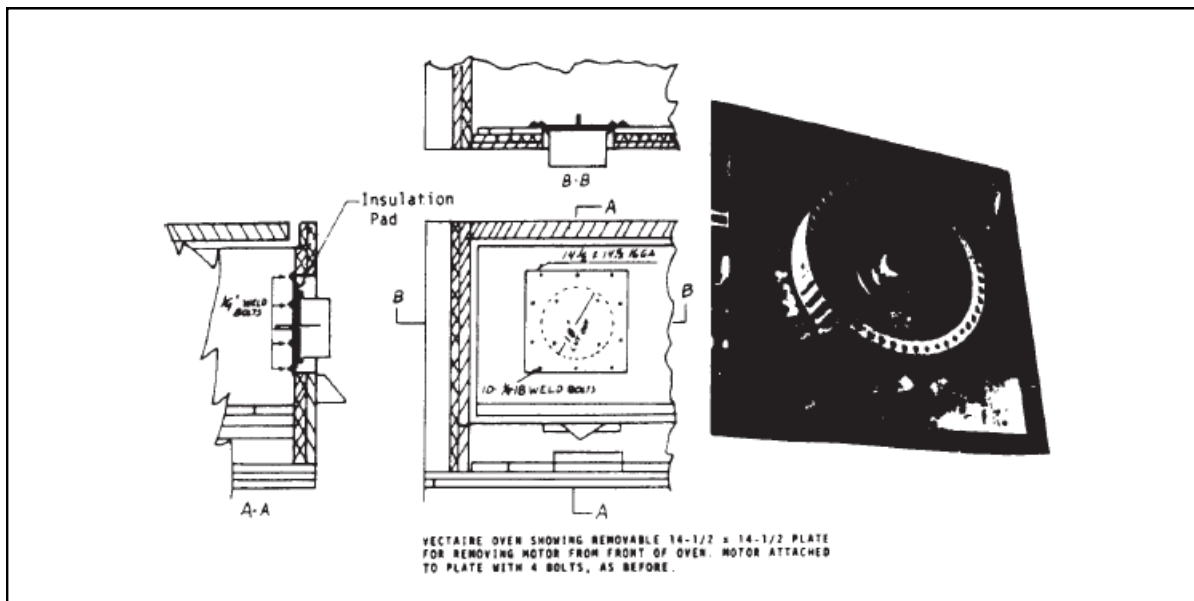

MOTORS – One of the following is used on each oven:  
Electrical characteristics

PART NO.	MFR	HP	SPEED	VOLTAGE	HZ	PH
01402-8	Baldor	3/4	1	115 / 230	60	1
02167-9	Howell	3/4	1	115 / 230	60	1
01397-8	Howell	3/4	2	115	60	1
06371-1	Howell	3/4	2	208 / 230	60	1
01403-6	Baldor	3/4	1	115 / 230	50	1
01404-4	Baldor	3/4	1	230 / 440	60	3



MODELS WITH SUFFIX "Z"

Removal of Gear Panels

1. Remove burner compartment panel.
2. Remove screw from lower edge of gear panel. Pull bottom edge of panel forward so that top of panel clears upper door rod.

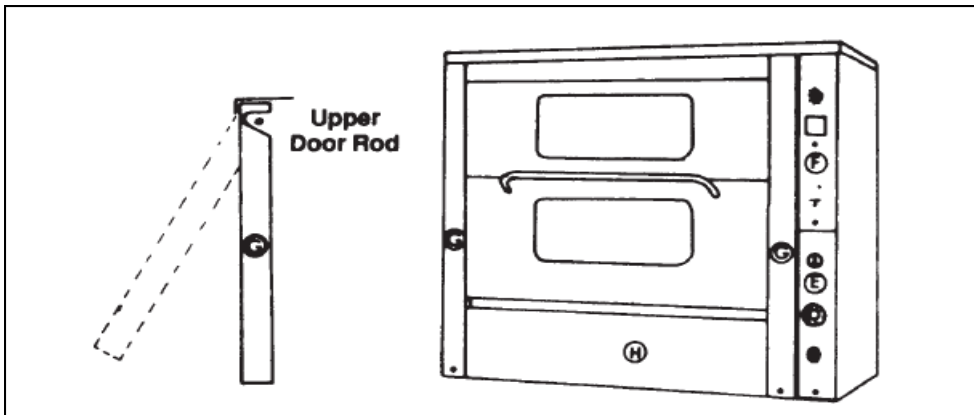

Synchronize Oven Door

1. Remove left & right gear panels.
2. Loosen Bolt "A" (steps 2-5 should apply to both upper bearings). 0))
3. Loosen Bolt holding Bearing "E" so that Gear Rack "F" slacks off enough to allow corrugations to slide up or down on "C". NOTE: If upper door extends out, raise door. If lower door extends out, lower door.
4. Tighten Bolt "A".
5. Tighten Bolt holding Bearing "E".
6. Check Door Seal, adjust if needed.

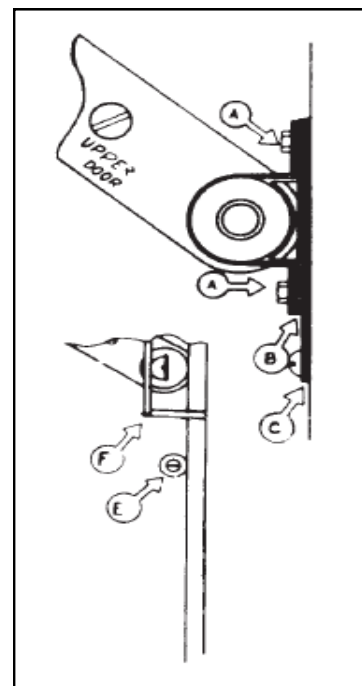

## SERVICE

### Adjusting Door Seal

It is important that the door seal be maintained across entire door but not too tight.

1. Loosen Bolts "D"
2. Doors will slide up or down.
3. Tighten up Bolts "D".

NOTE: If after doors are synchronized there is not enough adjustment in bolt holes "D", it will be necessary to loosen Bearing "E", move Gear Rack "F" up or down one tooth as needed. Door will have to be synchronized again.

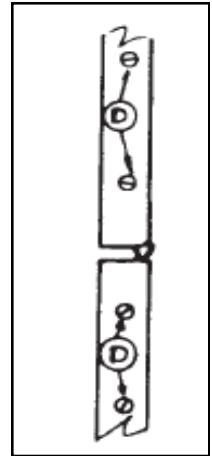

### OPERATION DIFFICULTIES AND PROBABLE CAUSES

#### Fan Shuts Off, Light in Oven On

1. Door open.
2. Door switch needs adjusting.
3. Motor overheating from lack of air circulation. Comes on when motor is cool.
4. Loose connection.
5. Fan or Door switch defective.

#### Fan Will Not Shut Off When Door Is Open

1. Door switch needs adjusting or defective.
2. Fan switch is "Cool" positive.
3. Fan switch is defective.

#### Fan and Light Off

1. Electrical power supply turned off.
2. Plug disconnected.

#### Pilot Burner Goes Out - Except Models with Suffix "EI"

1. Main gas shut off valve turned off.
2. Minimum flame set too low and blows it out upon ignition of main burner.
3. Poor draft in flue snuffs out flame.
4. Too much draft - pulls flame away from thermocouple.
5. Pilot flame too low.
6. Thermocouple defective.
7. Thermocouple connection on safety pilot loose.
8. Pilot orifice dirty.
9. Safety pilot valve defective.

#### Burner Fails to Come on Though Pilot On

#### Gas Thermostat (Models with suffix "G")

1. Main shut off valve turned off.
2. Orifice plugged.
3. Thermostat completely out of calibration.

Electric Thermostat (Models with suffix "E, EI")

1. Electric plug out.
2. Electric terminal loose.
3. Defective solenoid valve.

Oven Burner Will Not Shut Off or Oven Gets Too Hot

Gas Thermostat (Models with suffix "G")

1. Oven thermostat out of calibration.
2. Minimum flame too high. (Do not lower under 1/4").
3. Broken capillary tube.
4. Dirt under thermostat valve seat.

Electric Thermostat (Models with suffix "E, EI")

1. Oven thermostat out of calibration.
2. Broken capillary tube.
3. Wire shorting across thermostat terminals.
4. Dirt under seat of solenoid valve.

Oven Controls Overheating

1. Hole in top covered.
2. Range installed on control side conducting heat to control compartment, (insulate side of oven).
3. Oven setting on curb without 111 toe base or legs.
4. Poor draft in flue. Heat coming out from of burner compartment and being pulled up into control compartment instead of going out rear flue opening.
5. Door seal leaking.

Poor Heat Distribution - Hot Spots (See Baking Difficulties)

1. Too low gas input.
2. Thermostat out of calibration.
3. Fan not on.
4. Too much draft or too little draft in flue.
5. Poor seal across center of door.
6. Baffle too far from fan.
7. Foreign matter or obstruction in fan wheel or back of baffle.
8. Thermostat set too high.

Oven Takes a Long Time and/or Will Not Reach Temperature

1. Oven out of calibration.
2. Gas pressure too low.

Door Sticks or Not Closing Properly - Models with suffix "Z"

1. Gear rack interfering with spring assembly arm.
2. Broken spring.
3. Door out of synchronization.
4. Upper door hits top before stops on lower door makes a contact.

# SERVICE

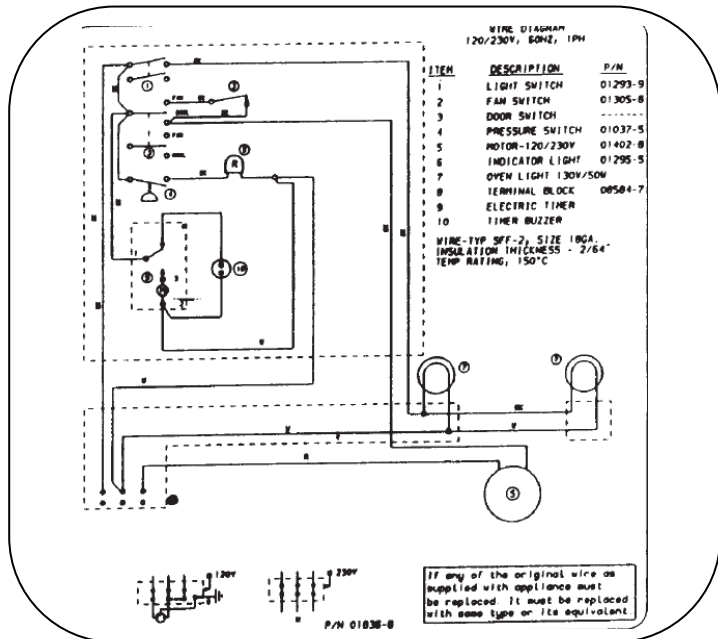

Model with Suffix "G"

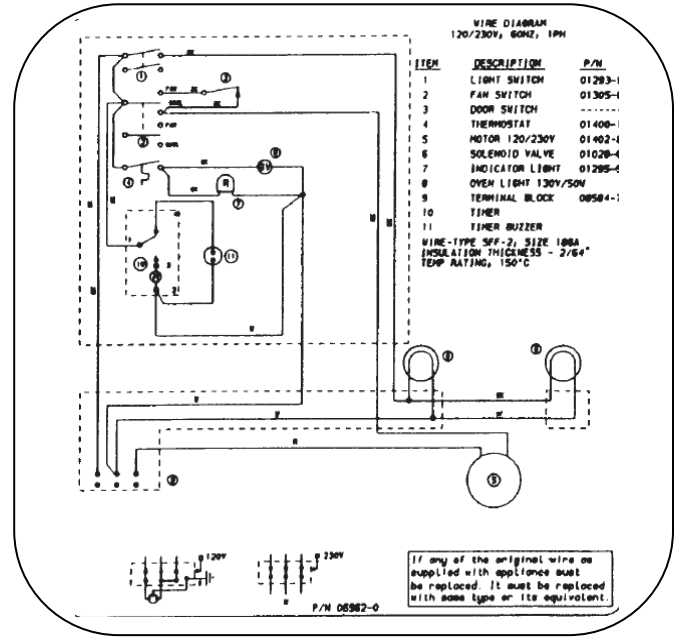

Model with Suffix "F"

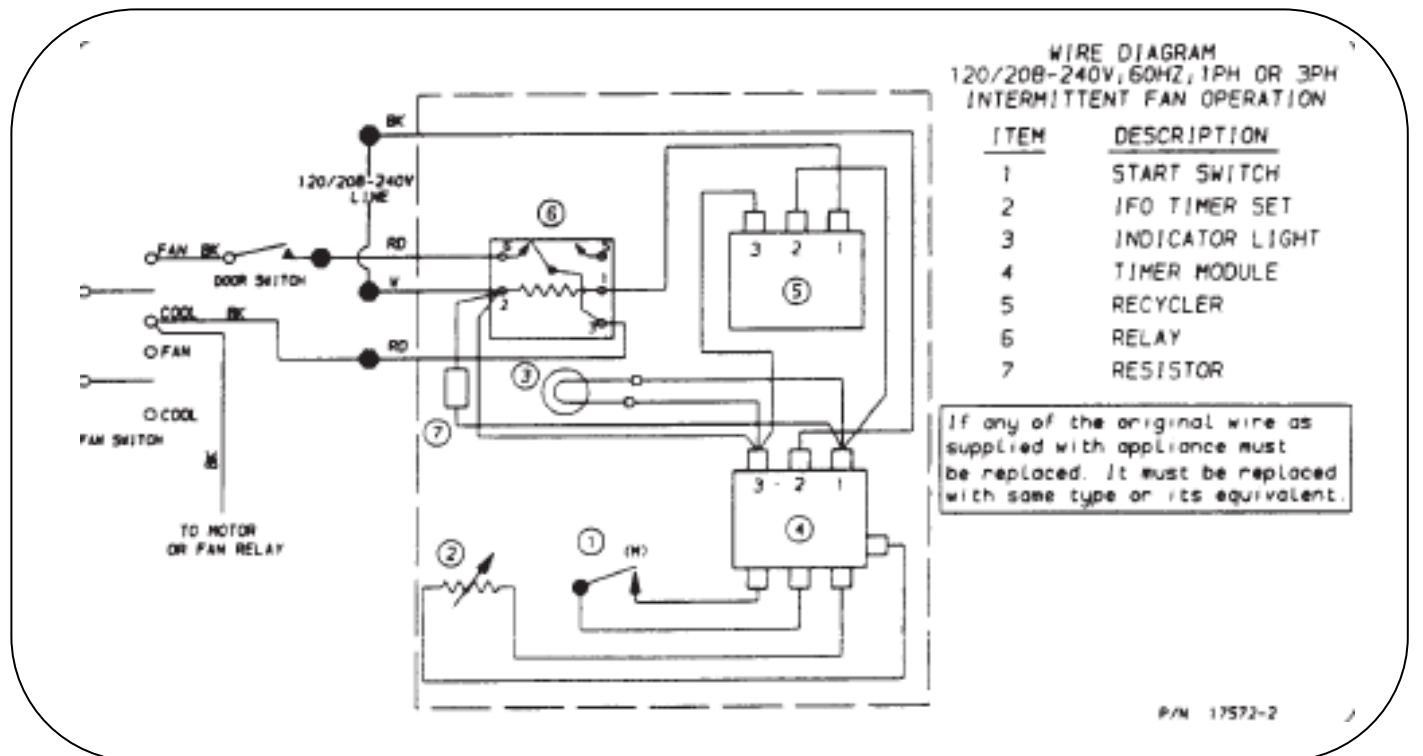

Intermittent Fan Operation

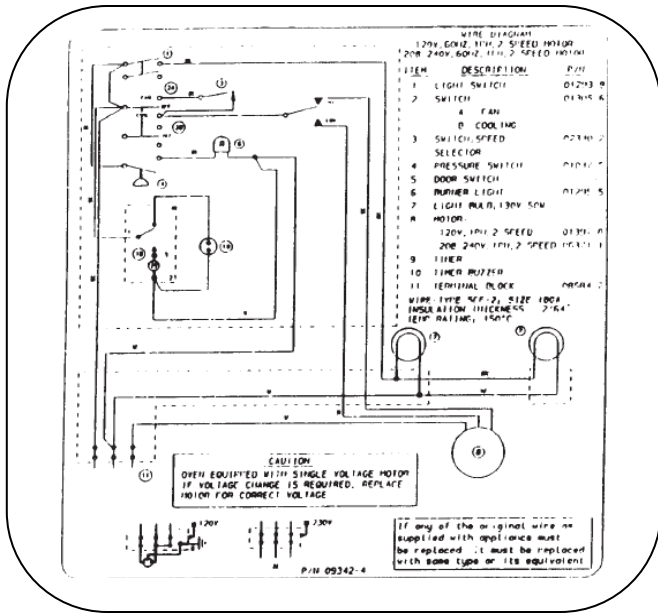

Model with Suffix "G" — 2 speed Motor

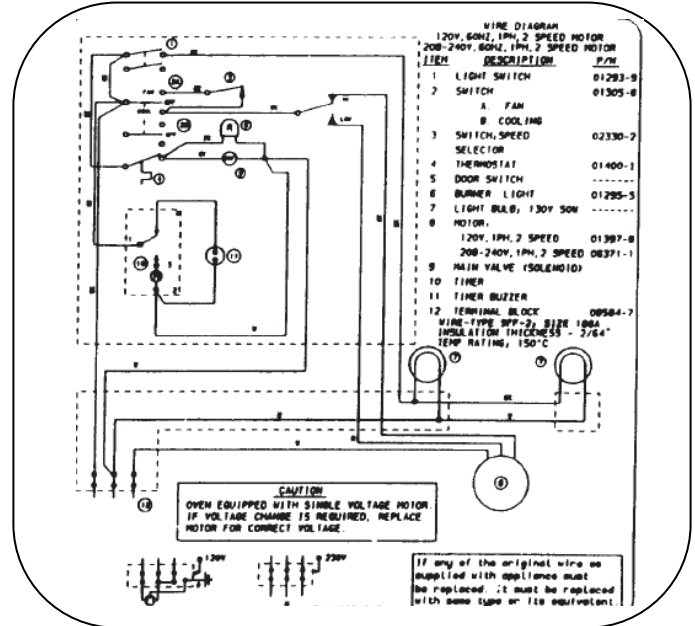

Model with Suffix "E" — 2 speed Motor

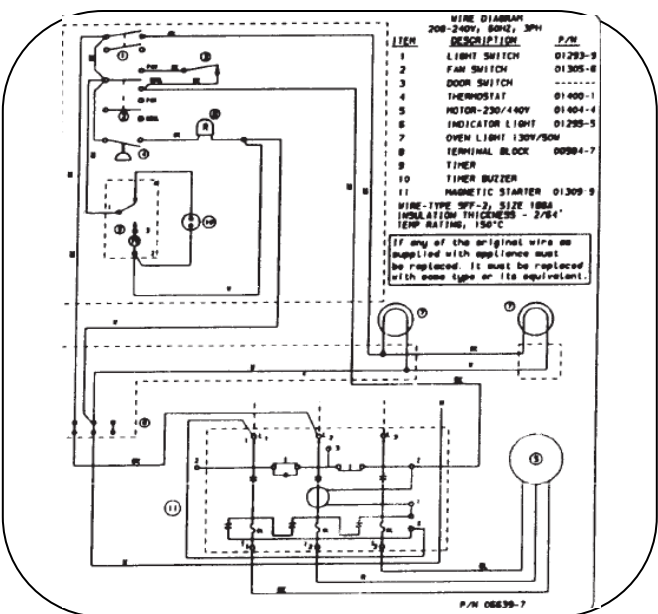

Model with Suffix "G" — with Magnetic Starter

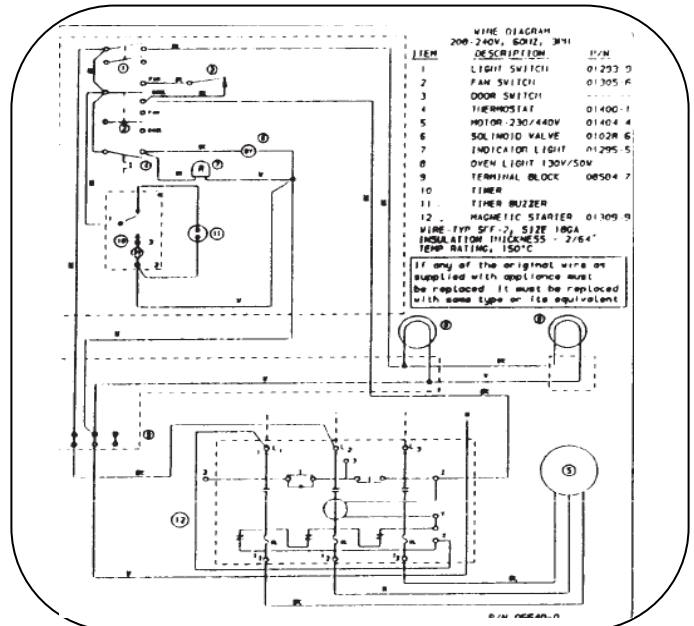

Model with Suffix "E" — with Magnetic Starter

# SERVICE

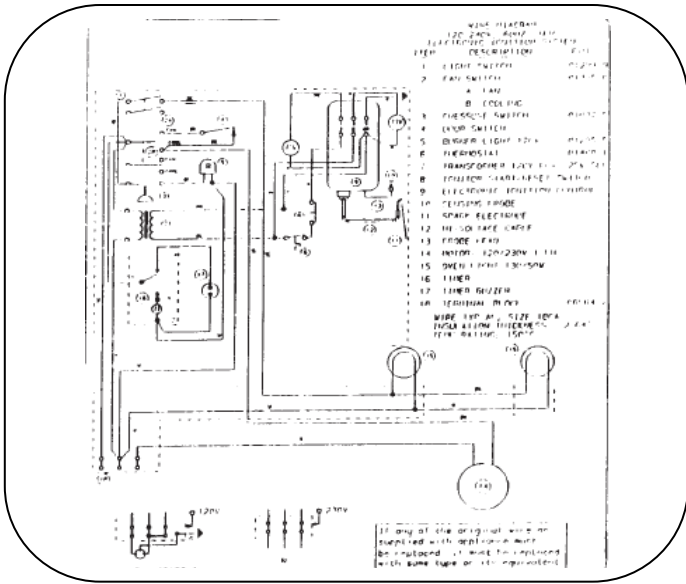

Model with Suffix "E1" — 1 Speed Motor  
120-240V, 60 Hz, 1PH

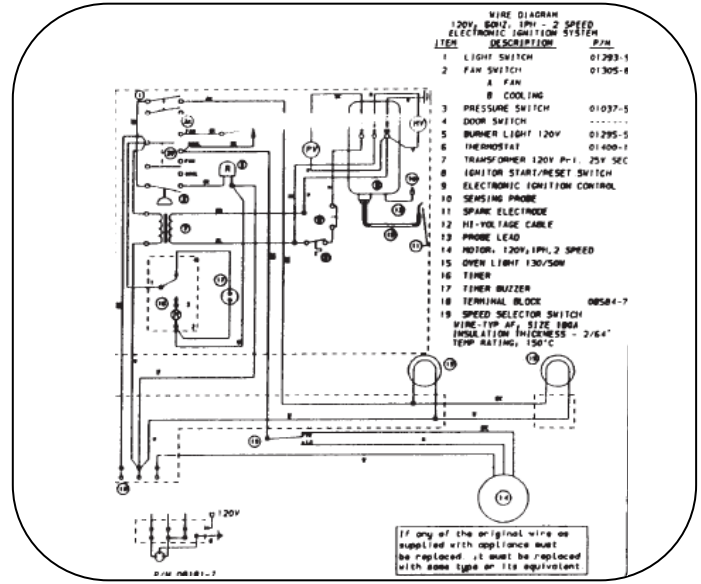

Model with Suffix "E1" — 2 Speed Motor  
120V, 60 Hz, 1PH

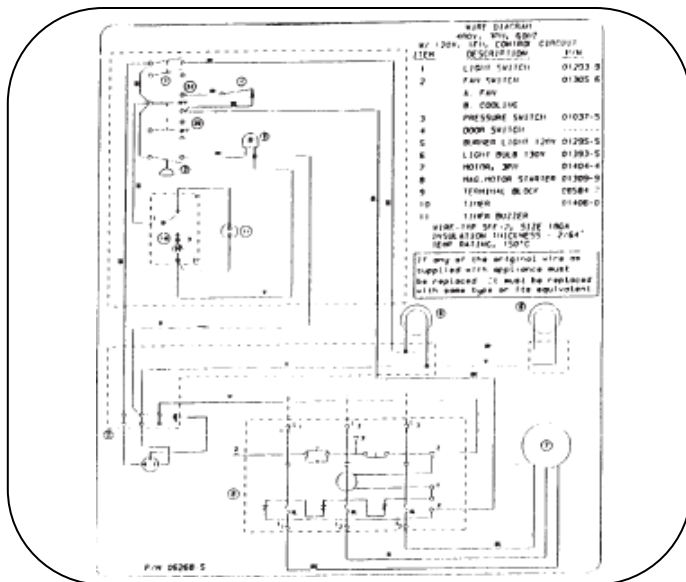

Model with Suffix "E"  
480V, 60Hz, 3 PH w/ 120V Control Circuit

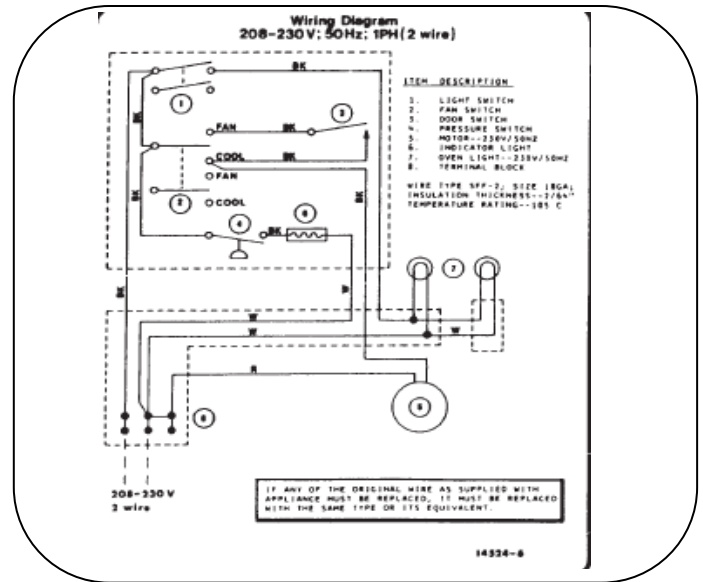

Model with Suffix "E" — 50 Hz

---

## R85 Kits

RSI	Single Unit Accessory Kit - Black includes: Gusset Legs; Single Unit Flue Deflector; Attaching Hardware	<a href="#">29241-9</a>
RSI	Single Unit Accessory Kit - SIS includes: Gusset Legs; Single Unit Flue Deflector; Attaching Hardware	<a href="#">29242-7</a>
RD1	Double-stack Accessory and Flue Kit - Black includes: 6" Legs; Double-stack Flue Deflector; Flue Collector; Flue Riser; Attaching Hardware	<a href="#">29243-5</a>
RD1	Double-stack Accessory and Flue Kit - S/S includes: 6" Legs; Double-stack Flue Deflector; Flue Collector; Flue Riser; Attaching Hardware	<a href="#">29244-3</a>
RS2	Single Unit Draffhood Kit - Black includes: Single Unit Draffhood, which replaces single unit flue deflector	29245-1
RS2	Single Unit Draffhood Kit - S/S includes: Single Unit Draffhood, which replaces single unit flue deflector	29247-8
RD2	Double-stack Draffhood Kit - Black includes: Double-stack Unit Draffhood, which replaces double-stack flue deflector, and flue box	29248-6
RD2	Double-stack Draffhood Kit - S/S includes: Double-stack Unit Draffhood, which replaces double-stack flue deflector, and flue box	29249-4

**15Z Series VECTAIRE**  
**Gas Convection Oven**  
**Horizontal Door Model**

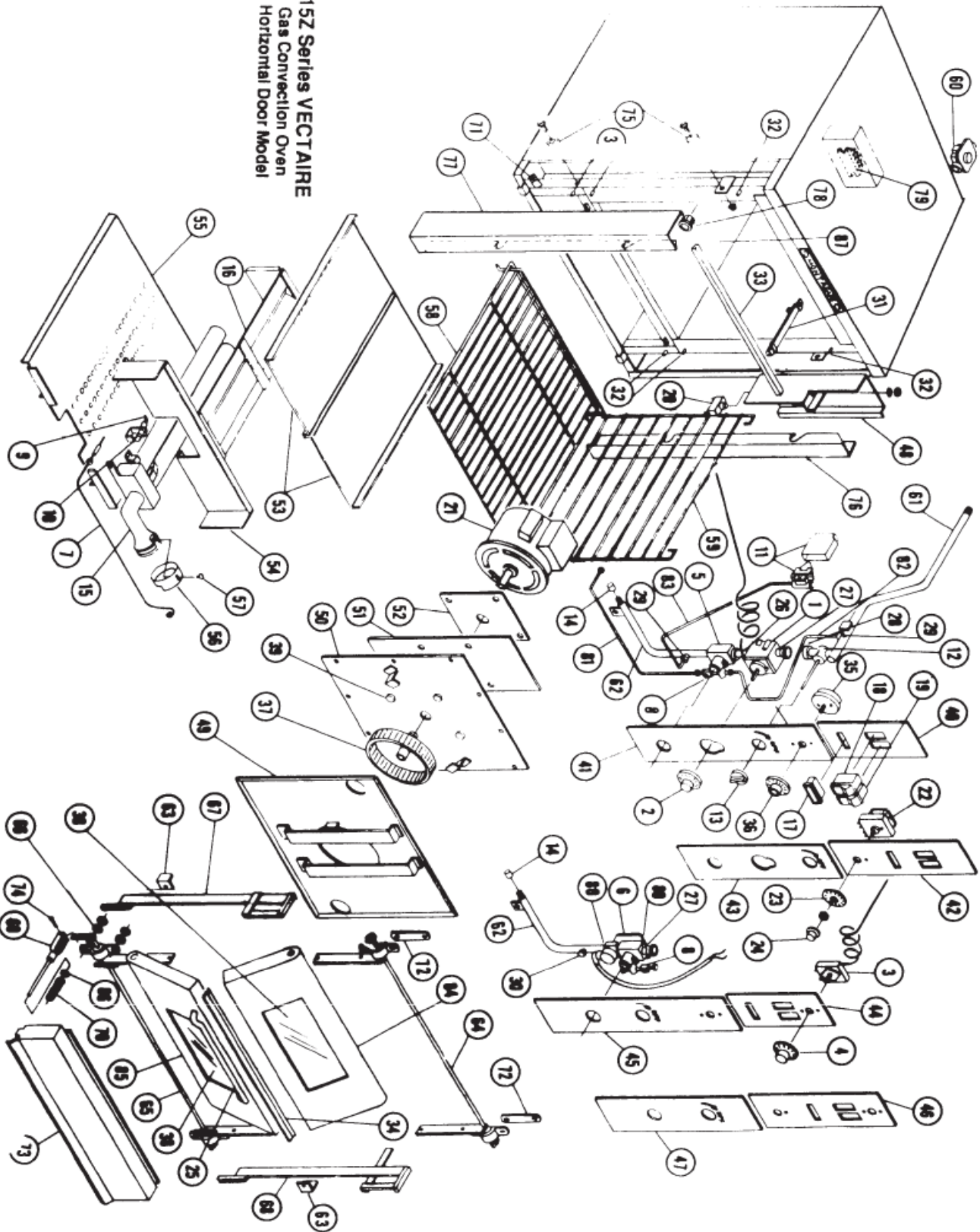



## VECTAIRE Gas Convection Oven-Horizontal Door Model

1	3395-2	Thermostat, Gas (FDO)	42	4562-4	Panel, Upper (Elec. Timer)
2	1024-3	Dial, Thermostat-Gas	43		Panel, Lower 1
3	3499-1	Thermostat, Electric (KX)	44	4309-5	Panel, Upper El. Therm. (Mech. Timer)
4	1979-8	Dial, Thermostat-Electric	45	4308-7	Panel, Lower 11
5	1025-1	Safety Valve, Gas Thermostat	46	4564-0	Panel, Upper (Elec. Timer)
6	1028-6	Safety Valve, Elec. Therm. (c#1 2)	47	4563-2	Panel, Lower
6	1031-6	Safety Valve, Elec. Therm. (G#1 -11)	48		Panel, Switch Box Enclosure
7	1036-7	Thermocouple	49	1522-9	Rear Fan Baffle, Porcelain
8	1051-0	Pilot Valve	50	4375-3	Motor Mounting Plate
9	1033-2	Pilot Burner-Natural Gas	51	1757-4	Insulation Pad, Motor
9	1034-0	Pilot Burner-Propane Gas	52	4385-0	Spacer Plate, Motor
10	2220-9	Orifice, Pilot-Natural Gas	53	4583-7	Top, Burner Box Plate (2 piece)
10	2154-7	Orifice, Pilot-Propane Gas	54	7006-8	Front, Burner Box
11	22325-5	Pressure Switch	55	7779-8	Perf. Bottom, Burner Box
12	1038-3	Main Valve	55	34895-3	Perf. Bottom, Burner Box-R85 (after 1/05)
13	2122-9	Knob, Main Valve (Red)	56	4494-6	Air Shutter
14	1044-8	Orifice, Main Burner-Natural Gas	57	1860-0	Bolt, Wing 1/4-20
14	6150-6	Orifice, R85, Natural; 2 req'd. (after Jan.'05)	58	1590-3	Rack, Oven Standard
14	1042-1	Orifice, Main Burner-Propane Gas	59	1594-6	Rack Guide, Right
14	2277-2	Orifice, R85, Propane; 2 req'd. (after Jan.'05)		1593-8	Rack Guide, Left (Not Shown)
15	4349-4	Main Burner-Natural Gas	60	1039-1	Regulator-Natural Gas (3/4")
15	4355-9	Main Burner-Propane Gas	60	1040-5	Regulator-Propane Gas (3/4")
15	32431-0	Burner Assy-R85 (after Jan.'05)	61	6851-9	Manifold, Main (3/4")
16	4344-3	Deflector (S/S)	62	1099-5	Manifold, Lower (1/2")
16	34904-6	Deflector (S/S)-R85 (after Jan.'05)	62	34934-8	Manifold Assy.-R85 (after Jan.'05)
17	1295-5	Light, Indicating "Burner" (110V)	63	4433-4	Guide, Gear Rack
18	1293-9	Switch, Light	64	3578-5	Trunnion, Upper Door
19	1305-6	Switch, Fan-Off-Cool	65	3575-0	Trunnion, Lower Door
20	1300-5	Switch, Door	66	1904-6	Spacer, Door (1/2")
21	1402-8	Motor, 115/208-240V 1 PH 60Hz Baidor	67	*3596-3	Gear Rack, Left
21	2167-9	Motor, 11 5/208-240V 1 PH 60Hz Howell	68	**3611-0	Gear Rack, Right
21	1404-4	Motor, 230/440V 3PH 60Hz Baldor	69	3408-8	Yoke with Guide Pin
22	1406-0	Timer, Electric-1 1 OV	70	2024-9	Spring, Door Assembly
22	1407-9	Timer, Electric-220V	71	3411-8	Replacemant Yoke Pin Guide
23	2044-3	Dial, Electric Timer	72	3597-1	Spacer, Upper Trunnion
24	2041-9	Knob, Electric Timer	73	4411-3	Firebox Panel (S/S)
25	3173-9	Handle, Oven Door	74	3412-6	Pin, Yoke
26	1150-9	Nipple, 3/8"x 2"	75	3413-4	Bearing with Bolt and Nut
27	1149-5	Nipple, 3/8"x 1-1/2"	76	6015-1	Panel, Right Gear Cover
28	1183-5	Union, 3/8"	77	4581-0	Panel, left Gear Cover
29	1277-7	Fitting-1/8" NPT x 1/4" CC	78	1408-7	Light Socket
30	1279-3	Plug, 1/8"NPT	79	8584-7	Terminal Block
31	6156-5	Holder, Capillary Tube	80	1119-3	Bushing, 3/8"x 1/2" NPT
32	1944-5	"D" Bolt, 5/16" x 1 "	81	1229-7	Tube, Safety Valve to Pilot
33	4376-1	Door Seal, Upper-Metal	81	25013-9	Tube, Manifold to Valve-R85(1/05)
34	4381-8	Door Seal, Center-Metal	82	1225-4	Tube, Manifold to Safety Valve
35	2125-3	Timer, Mechanical	84	4348-6	Upper Door with Window
36	2043-5	Dial, Mechanical Timer	85	3606-4	Lower Door with Window
37	2123-7	Fan Wheel with Set Screw	86	3488-6	Keeper, Door Bearing
38	2124-5	Window	87	1524-5	Oven Bottom, Porcelain
39	1945-3	Bolt, Motor Mounting	88	6949-3	Pilot Shield
40	11752-8	Panel, Upper Gas Therm. (Mech. Timer)			
41	11750-1	Panel, Lower 1.			

\*Left gear racks for oven prior to 1963-P/N 3610-2

\*\*Right gear racks for ovens prior to 1974—consult with factory for correct number and

**115A Series VECTAIRE**  
**Gas Convection Oven**  
**Vertical Door Model**

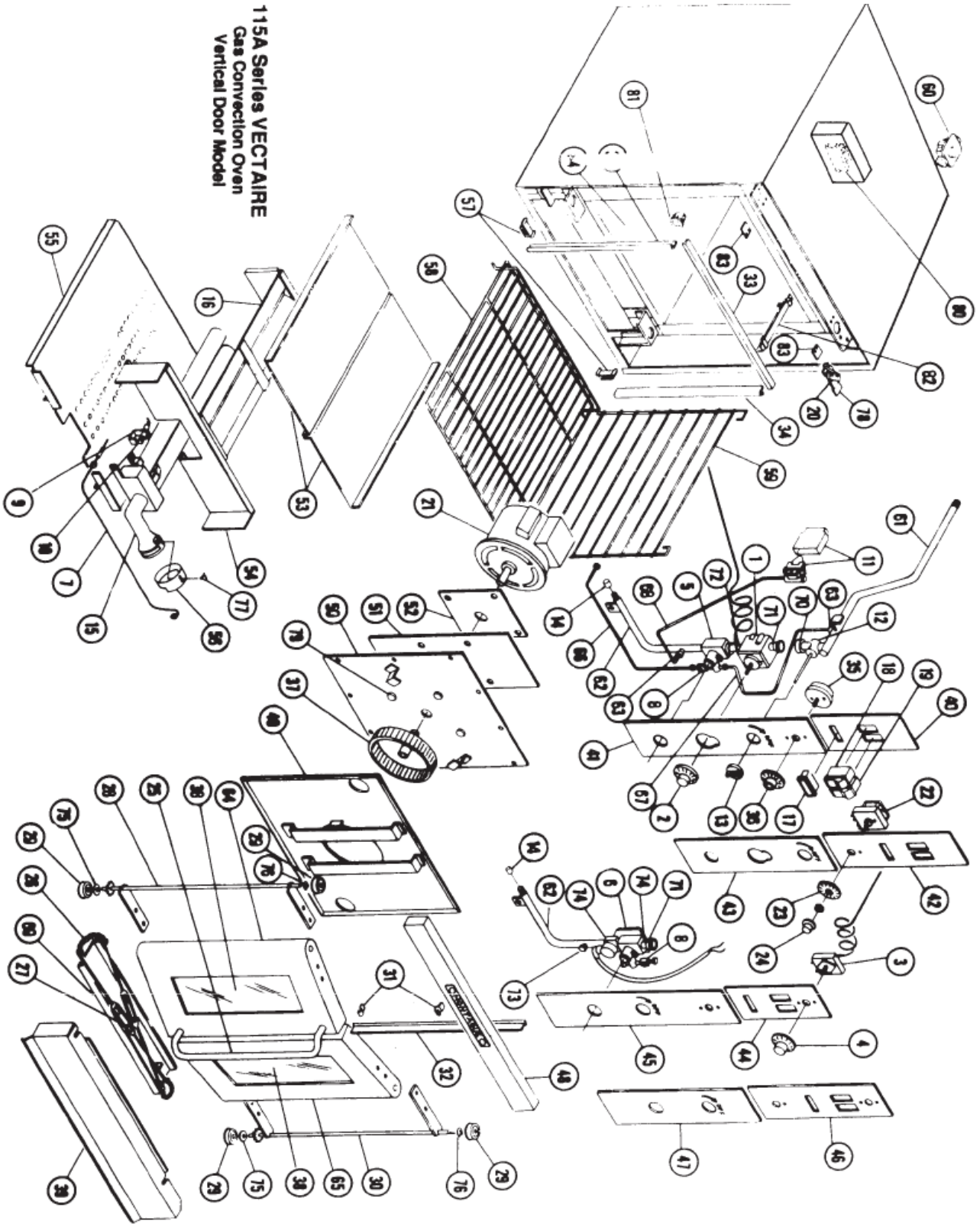

## VECTAIRE Gas Convection Oven-Vertical Door Model

1	3395-2	Thermostat, Gas (FDO)	41	4487-3	Panel, Lower
2	1024-3	Dial, Thermostat—Gas	42		Panel, Upper (Elec. Timer)
3	3499-1	Thermostat, Electric (KX)	43		Panel, Lower 11
4	1979-8	Dial, Thermostat-Electric	44	6958-2	Panel, Upper El. Therm. (Mech. Timer)
5	1025-1	Safety Valve, Gas Thermostat	45	4459-8	Panel, Lower 1.
6	1028-6	Safety Valve, Elec Therm. (c#12)	46		Panel, Upper (Elec. Timer)
6	1031-6	Safety Valve, Elec. Therm. (c#1 -11)	47		Panel, Lower 1.
7	1036-7	Thermocouple	48	4575-6	Capping Panel, Upper Front (S/S)
8	1051-0	Pilot Valve	49	1522-9	Rear Fan Battle, Porcelain
9	1033-2	Pilot Burner—Natural Gas		4375-3	Motor Mounting Plate
9	1034-0	Pilot Burner—Propane Gas	51	1757-4	Insulation Pad, Motor 8
10	2220-9	Orifice, Pilot—Natural Gas	53	4583-7	Top, Burner Box Plate (2 piece)
10	2154-7	Orifice, Pilot-l'mr-ine Gas	54	7006-8	Front, Burner Box
11	1037-5	Pressure Switch	55	7779-8	Perf. Bottom, Burner Box
12	1038-3	Main Valve	55	34895-3	Perf. Bottom, Burner Box-R85 (after 1/05)
13	1122-9	Knob, Main Valve (Red)	56	4494-6	Air Shutter
14	1044-8	Orifice, Main Burner-Natural	57	6949-3	Pilot Shield
14	6150-6	Orifice, R85, Natural; 2 req'd. (after Jan.'05)	57	2040-0	Magnet, Firebox Panel
14	1042-1	Orifice, Main Burner-Propane	58	1590-3	Rack, Oven Standard
14	2277-2	Orifice, R85, Propane; 2 req'd. (after Jan.'05)	59	1594-6	Rack Guide, Right
15	4349-4	Main Burner-Natural Gas		1593-8	Rack Guide, Left (Not Shown)
15	4355-9	Main Burner-Propane Gas	60	1039-1	Regulator-Natural Gas (3/4")
15	32431-0	Burner Assy-R85 (after Jan.'05)	60	1040-5	Regulator-Propane Gas (3/4")
16	4344-3	Deflector (S/S)	61	6851-9	Manifold, Main (3/4")
16	34904-6	Deflector (S/S)-R85 (after Jan.'05)	62	1099-5	Manifold, Lower (1/2")
17	1295-5	Light, Indicating "Burner"(110V)	62	34934-8	Manifold Assy.-R85 (after Jan.'05)
18	1293-9	Switch, Light	63	1277-7	Fitting-1/8" NPT x 1/4" CC
19	1305-6	Switch, Fan-Off -Cool	64	3607-2	Door, Handle Side
20	1300-5	Switch, Door	65	3608-0	Door, Right Side
21	1402-8	Motor, 115/208-240V 1 PH 60Hz Baldor	66	1229-7	Tube, Safety Valve to Pilot
21	2167-9	Motor, 115/208-240V 1 PH 60Hz Howell	66	25013-9	Tube, Manifold to Valve-R85(1/05)
21	1404-4	Motor, 230/440V 3PH 60Hz Baldor	67	1225-4	Tube, Manifold to Safety Valve
22	1406-0	Timer, Electric-110V	69	4399-0	Guard, Chain Assembly
22	1407-9	Timer, Electric-220V	70	1183-5	Union, 3/8"
22	4385-0	Spacer Plate, Motor	71	1149-5	Nipple, 3/8" x 1- 1/2"
23	2044-3	Dial, Electric Timer	72	1150-9	Nipple, 3/8" x 2"
24	2041-9	Knob, Electric Timer	73	1279-3	Plug, 1/8" NPT
25	3173-9	Handle, Oven Door	74	1119-3	Bushing, 3/8" x 1/2" NPT
26	2016-8	Chain, Oven Door	75	1904-6	Spacer, Door (1/2')
27	3172-0	Turnbuckle-with Rods	76	1961-5	Keeper, Door Trunnion
28	3239-5	Trunnion, Left	77	1860-0	Bolt, Wing 1/4-20
29	2014-1	Bearing, Oven Door	78	11869-9	Bracket, Door Switch
30	3585-8	Trunnion, Right	79	1945-3	Bolt Motor Mounting
31	3414-2	Spring Clip, Door (2 each)	80	8584-7	Terminal Block
32	4379-6	Door Seal, Center-Metal	81	1408-7	Light Socket
33	4376-1	Door Seal, Upper-Metal	82	6156-5	Holder, Capillary Tube
34	4378-8	Door Seal, Side-Metal	83	3488-6	Keeper, Door Bearing
35	2125-3	Timer, Mechanical	84	1524-5	Oven Bottom, Porcelain
36	2043-5	Dial, Mechanical -Timer			
37	2123-7	Fan Wheel with Set Screw			
38	2124-5	Window			
39	3593-9	Firebox Panel, Clip Style (S/S)			
39	7068-8	Firebox Panel, Magnet Style (S/S)			
40	6967-1	Panel, Upper Gas Therm. (Mech. Timer)			

## **WARNING**

**If not installed, operated and maintained in accordance with the manufacturer's instructions, this product could expose you to substances in fuel or in fuel combustion which can cause death or serious illness and which are known to the State of California to cause cancer, birth defects or other reproductive harm.**

The State of California enacted the California Safe Drinking Water and Toxic Enforcement Act of 1986, (Prop. 65), which "prohibits any person in the course of doing business from knowingly and intentionally exposing any individual to a chemical known to the State of California to cause cancer or reproductive toxicity without first giving clear and reasonable warning to such individuals." The Governor's Scientific Advisory Panel added carbon monoxide to the list of hazardous chemicals known to cause reproductive harm.

In order to establish full compliance with Proposition 65, we attached a yellow warning label to each gas fired unit manufactured by the Montague Company.

Carbon monoxide would not be present in concentrations that would pose a "significant risk" to the consumer when the equipment is installed, operated and maintained as follows:

1. Installed in accordance with all local codes, or in the absence of local codes, with the current National Fuel Gas Code Z223.1.
2. Installed under a properly designed and operating exhaust hood.
3. Connected to the type of gas for which the unit is equipped.
4. Proper appliance pressure regulator installed on the gas supply line and adjusted for the manifold pressure marked on the rating plate.
5. Adequate air supply to the unit.
6. The equipment is operated in the manner intended using the proper utensil for that type of appliance.
7. Keep the equipment clean and have it checked periodically.
8. Burner air adjustments, mechanical maintenance and repairs should be performed by qualified service personnel.

If the equipment is not installed, operated and maintained in accordance with the above, concentrations of carbon monoxide in excess of the established limits could present in the kitchen environment.

ALL PERSONNEL IN THE WORKPLACE WHO MAY BE SUBJECT TO ANY EXPOSURE OF CARBON MONOXIDE MUST BE WARNED OF SUCH POSSIBLE EXPOSURE. THIS WARNING SHOULD BE CONVEYED IN A MANNER SO THAT IT IS CLEARLY UNDERSTOOD BY THE EMPLOYEE, AND THE EMPLOYEE SHOULD BE ASKED IF IN FACT HE OR SHE UNDERSTANDS THE CORRECT METHOD OF OPERATION OF THE EQUIPMENT AND THAT A RISK OF EXPOSURE EXISTS IF THE EQUIPMENT IS OPERATED IMPROPERLY.



**The MONTAGUE COMPANY**  
1830 Stearman Avenue, P.O. Box 4954 Hayward, CA 94540-4954

# **IMPORTANT**

When ordering part, to eliminate mistakes and facilitate delivery, always give the following information:

Serial No. \_\_\_\_\_

Model No. \_\_\_\_\_

Change No. \_\_\_\_\_

## **Name & No. of Part**

**Model No.    Change No.    Serial No.**

A diagram illustrating the layout of a part name and number. It consists of a large outer rectangle containing four smaller shapes: three horizontal rectangles and one square. The three rectangles are arranged horizontally from left to right. Lines connect the labels 'Model No.', 'Change No.', and 'Serial No.' (from the block above) to the top-left corners of the three rectangles respectively. The square is positioned to the right of the three rectangles.

The Montague Company  
1830 Stearman Avenue  
P.O. Box 4954  
Hayward, CA 94540-4954

(REV. B) P/N 4520-9 1/05