

Manufacturer:

**UNIFOREST** d. o. o.  
SI-3301 PETROVČE  
Tel.: 00386/3777 14 10  
E-mail: info@uniforest.si

## Instructions for use

### FORESTRY WINCH 65M/85M

Instructions for safe work  
Spare parts list



# GENERAL

## Dear customer!

We would like to congratulate you for the purchase of our machine. The hydraulic forestry winch is a forestry machine with a modern design and a construction which enables efficient and safe work in the woods. Work in the woods can only be safe if you observe the instruction for safe use. If you follow the instructions the machine will work perfectly and there will be no unnecessary expenses.

We recommend you to carefully read the user manual. In case of doubt do not hesitate to contact us.

We wish you safe work with the machine.

## 1. Index

<b>GENERAL</b>	<b>2</b>
1. Index	2
2. Intended use	3
3. Technical data	3
<b>SAFETY INSTRUCTIONS</b>	<b>4</b>
1. General	4
2. Cardan shaft	7
<b>USER MANUAL</b>	<b>8</b>
1. Description	8
2. Necessary tractor equipment	8
3. Adjustment of the cardan shaft	8
4. Attaching the winch to the tractor	9
5. Unreeling the wire rope	9
6. Winch controller	10
<b>SETTINGS</b>	<b>11</b>
1. Clutch	11
2. Safety brake	11
3. Brake	12
4. DRIVE CHAIN TENSIONING	13
5. WIRE ROPE ASSEMBLY	14
<b>MAINTENANCE LUBRICATION</b>	<b>14</b>
<b>TROUBLESHOOTING</b>	<b>15</b>
<b>Spare parts list</b>	<b>17</b>
<b>EC – Declaration of conformity</b>	<b>23</b>
<b>WARRANTY</b>	<b>24</b>

## 2. Intended use

The machine is designed exclusively for normal work in the woods. Any other use is considered as unintended. The manufacturer is not liable for any damage resulting from inappropriate use. In this case, the user takes all responsibility. Intended use also includes observing operational, handling and maintenance conditions specified by the manufacturer. The machine can be operated only by a person who is qualified and informed about the dangers and consequences of inappropriate use. Relevant safety regulations as well as general regulations on technical safety of devices, health regulations and road rules must be observed. The manufacturer is not liable for any damages that may arise from users making unauthorized changes on the machine.

## 3. Tehnični podatki:

	<b>Unit</b>	<b>65M</b>	<b>85M</b>
<b>Working group</b>	EM	1	1
Pulling force	kN	65	85
Brake force	kN	81,25	106,25
<b>Wire rope</b> medium speed	m/s	0,60	0,60
<b>Wire rope</b> <b>maximum</b> length	mm/m	10/165	10/120
		11/135	11/105
	mm/m	12/115	12/90
<b>Wire rope</b> length (serial)	mm/m	12/80	11/70
<b>Tractor</b> required power	kW	45-70	min. 50
	KM	61-95	min.68
<b>Tear force</b>	kN	120	160
Rated strength	N/mm <sup>2</sup>	2160	2160
Width	mm	1685	1800
Depth	mm	750	780
<b>Height</b> without protective net	mm	1830	1830
<b>Height</b> with protective net	mm	2300	2300
<b>Weight</b> (without wire rope)	kg	526	563
<b>Revolutions on</b> cardan	min <sup>-1</sup>	max. 540	max. 540

Option  Serial

## SAFETY INSTRUCTIONS

When working with the winch you need to observe the safety instructions!

**In order to prevent accidents carefully read and observe the following instructions:**

### 1. General:

1. Apart from the instructions in this user manual you should also observe all general safety and accident preventing regulations.



2. When working with the winch, it is necessary to comply with the rules of safety at work.
3. Only persons, who are older than 18, are allowed to work with the winch.
4. Safety and warning plates on the machine provide important instructions for safe use. Observe them for your safety.
5. The winch or its flawless operation should be checked before every use or at least once every working day. Defects should be removed by an expert. Before first use or after significant alterations and at least once a year the winch must be examined by an expert.
6. When using public transport routes observe traffic signs and regulations.
7. When using the winch wear personal protective equipment(helmet, gloves, appropriate footwear,...).
8. Before starting and driving check the surrounding area (children). Maintain adequate visibility.
9. Riding on the winch during transport is not allowed.
10. Connect the winch according to the instructions.
11. For on road travel the machine must be in the following condition. If the winch covers the rear lights of the tractor and they are not visible during transport on public roads, install additional lights on the winch.
12. Adjust the driving speed to the environmental conditions. When driving up or down or across a slope avoid sudden turning of the steering wheel.
13. Do not stand in the danger area.



14. If the tractor is not blocked against moving with a brake or wheel blocks, no person should be standing between the tractor and the winch.



15. Do not touch the winch until every part of the winch has stopped.
16. Check mounting bolts regularly.
17. Before use the winch must be visually inspected. At least once a year, the winch must be inspected by a professionally qualified person.
18. During any work on the winch you must turn the tractor off.

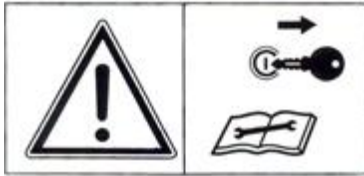

19. It is forbidden to remove the safety devices from the winch.
20. Use a tow rope of adequate strength and quality (see the factory plate).
21. A damaged wire rope must be replaced immediately.
22. If it is necessary to use a wire rope of an appropriate length. When you wind the rope up, a distance of 1,5 of rope diameter to outer diameter of the drum should stay on the drum. When you unreel the rope, a minimum of 3 rope wraps should stay on the drum.
23. The assistant is not allowed to connect load on the winch until he has informed the tractor driver about it.
24. It is especially dangerous to stand next to the tree that you are about to pull (Figure 1).
25. When using a relay pulley there is a triangular danger area, where you are not allowed to stay during the tow (Figure 2).



Figure 1

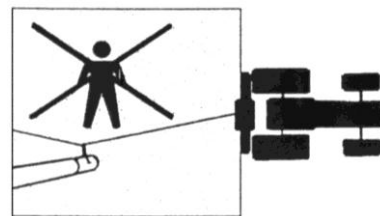

Figure 2

26. When towing observe the maximum allowed angle of 30° (Figure 3).
27. On uneven terrain or when not observing the maximum allowed towing angle there is a danger of the winch rolling over (Figure 6).

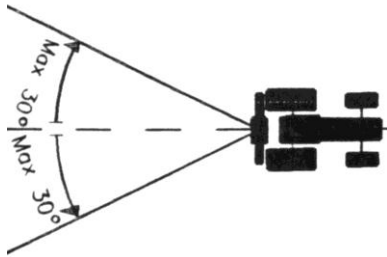

Figure 3

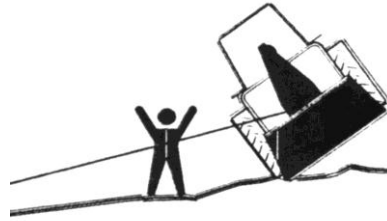

Figure 4

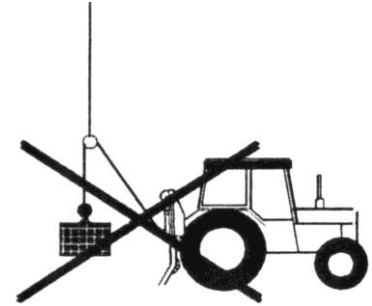

Figure 5

28. Do not use the winch for unintended purposes (lifting loads, etc.).(Figure 5)
29. Tractor driver and assistant must continuously communicate during their work.
30. The winch operator must continuously observe the load during the tow. If this is not possible due to the configuration of the terrain, the assistant should help.
31. The tractor to which the winch is connected to must have a minimum tyre profile which still meets the traffic regulations. Otherwise the wheels must be fitted with snow chains. Chains are also obligatory when working in snow and ice.
32. When disconnecting the winch, you first need to choose an appropriate hard and flat surface. Fix the winch by means of support legs. Lean the drive shaft on the prepared holder.
33. In the area of the three point linkage there is a danger of injuries due to compression or crushing.



34. The winch can be operated only from a safe place from which the load, wire rope, rope hook or the winch itself do not pose a threat to the operator. A safe place can also be the tractor seat if the winch has a safety net of sufficient size. When operating the winch outside the tractor seat the operator must be provided with an appropriate protection, e.g. the tractor itself, secure location at a sufficient distance from the vehicle, e.g. behind a tree. Logs can be monitored from the side next to the connection and shorter timber can be monitored diagonally behind the load. (See Figure 6).



35. During the tow, it is forbidden to stand between the load and the winch as well as in the danger area between the winch, relay pulley and load. (See picture 7).

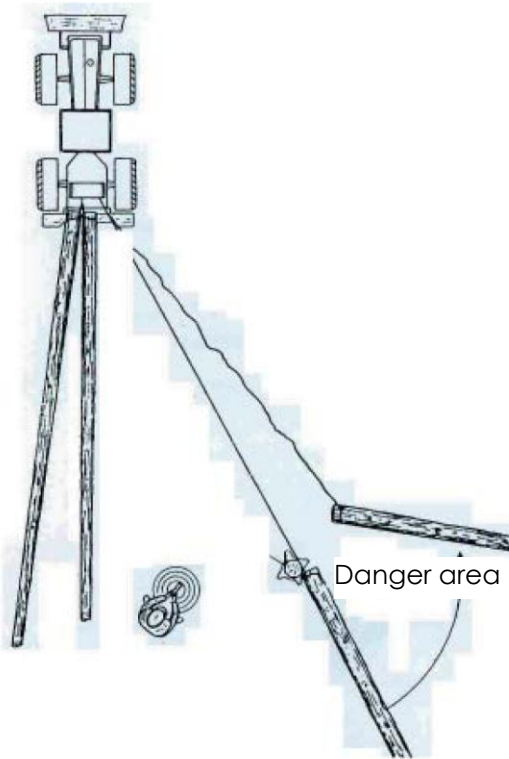

Figure 6

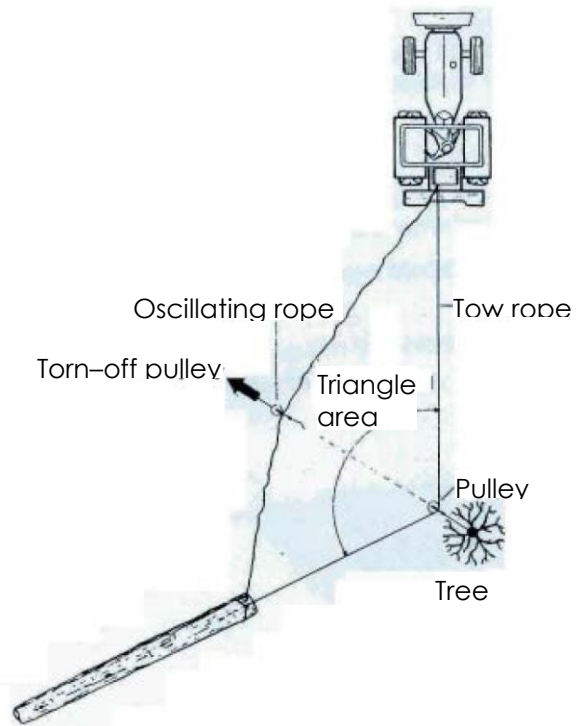

Figure 7

### **CARDAN SHAFT**

1. Only use such cardan shafts which are recommended by the manufacturer.
2. The cardan shaft protection pipes, protective funnels and attachment protection must be mounted on the machine and be in perfect condition.
3. Observe the recommended pipe protection in transport and working position.
4. The cardan shaft can only be connected or disconnected, when the cardan attachment is turned off, the engine has stopped and the ignition key has been removed.
5. The cardan shaft must always be properly mounted and protected.
6. Secure the cardan shaft against rotating with a chain.
7. Before switching on the cardan shaft on the tractor make sure that the chosen speed and direction of rotation match the requirements from the chapter Technical data.
8. Before switching on the cardan shaft make sure no person is standing in the danger area of the machine. This rule must also be observed during machine operation.
9. Never switch on the cardan shaft when the engine is turned off.
10. Put the disconnected cardan shaft on the intended holder.

# INSTRUCTIONS FOR USE

## 1. DESCRIPTION

A winch is a machine intended for harvesting felled timber from the forest. The basic components are: welded frame, drive part, drum with wire rope, clutch, brake and directional pulley. Using the wire rope, the logs can be towed to the moldboard and attached with forestry chains to the grooves on the winch frame. Then the logs can be transported to a place which is accessible by other means of transport.

## 2. REQUIRED EQUIPMENT OF THE TRACTOR

- PTO shaft with chosen gear ratio, max. 540 RPM.
- Three-point hitch of I and II category.

**Maximum number of revolutions and direction of tractor PTO shaft rotation is 540 min<sup>-1</sup>.**



## 3. PTO SHAFT ADJUSTMENT

Length of PTO shaft needs to be adjusted for different tractors (figure F1-F4). For winch 65M/85M, the use of PTO shaft with torque 695 Nm (type W 400E Walterscheid) is appropriate.

Ascertain the accurate length in the following manner:

1. Shut down the tractor.
2. Connect the machine to the tractor.
3. Extract the PTO shaft apart and connect the individual shaft halves to the tractor and machine and compare them crosswise and mark them (figure F1).
4. Shorten external and internal plastic protection pipes (figure F2).
5. Shorten external and internal slide profiles with the same distance as plastic protection pipes (figure F3).
6. Crop the pipe end, remove fillings and grease the slide positions well (figure F4).



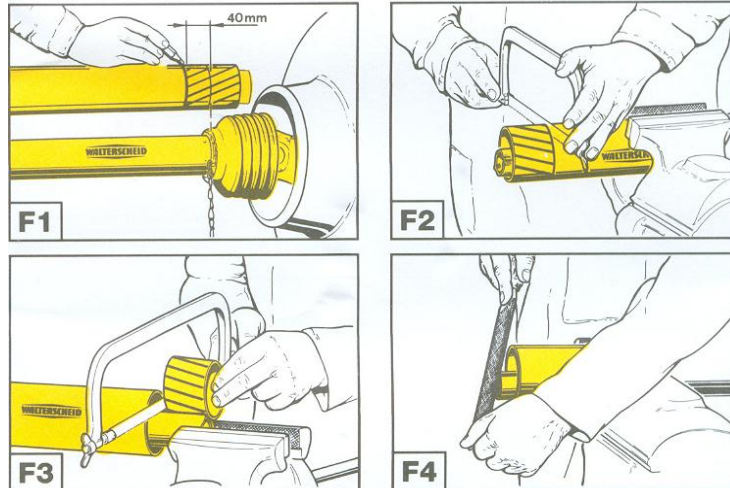

#### 4. TRACTOR MOUNTING

**When connecting the winch, do not stand in the danger zone!**

The forestry winch can be attached to every tractor with a three-point hitch with a category I or II coupling. Appropriate construction also enables easy connection to the tractor with automatic connection rods. Connect the prescribed PTO shaft and secure cardan protection with a hang chain.

Be careful that the cardan clicks into place on both connection points!

Once the winch is attached to the tractor, strengthen the stabilizers on the lower connection rods and level the winch with a hitch nut into position, so that the winch is tilted backwards for approximately 20 degrees.

#### 5. WIRE ROPE UNWINDING

##### Warning

**Steel rope must be completely unwound before first use and wind it back on the generator drum under load.**

For instance, we can do this so that we attach the rope to a standing tree and pull the tractor with slight braking to the tree. This procedure must be done also before trying to tow, if we towed downhill beforehand or if the rope was wound loosely during towing.

## **ATTENTION!**

Loosely wound steel rope can be damaged (stuck, bent) at greater load, so that it is prohibited to use it again.

**Warranty does not apply for a steel rope, which is damaged in such manner.**

Once the winch is properly connected to the tractor, you can start unreeling the wire rope. Pull the wooden lever on a red string (pos. 3, figure 11) and thus move lever 2 to the OFF position (figure 11). The brake is released and the wire rope can be unreeled. In case you have just installed the wire rope on the drum or you have noticed that the wire rope is not installed properly, you should unreel the entire wire rope and then reel it back tightly, as described in the beginning of this chapter.

## **6. Towing**

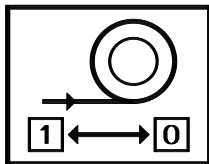

Figure 9

Lower the winch on the ground so that the winch is supported by a hard surface. Engage the hand brake. Never start towing if a winch is not in a stable position on

the ground.

Before you pull the black string (pos. 10, figure 11), check that the string is installed properly between the small pulleys (pos. 9, figure 11). The lever (pos. 1, figure 11) should return to its original OFF position as soon as you stop pulling the string (pos. 10, figure 11).

**If this string is not wound properly, it may happen that you will not be able to stop the towing, which can lead to an accident.**

**Any interference with the activation mechanism which would prevent synchronous operation of clutch and brake is prohibited. It is also forbidden to pull the red brake string (pos. 3, figure 11) during the towing.**

**It is forbidden to lift the hydraulic linkage during the towing (it can lead to a malfunction of the PTO shaft).**

# SETTINGS

## 1. Clutch

A properly set clutch enables optimal traction force. The clutch was factory set during the testing of the winch, but due to friction surface wear, it eventually must be set anew.

**The re-setting is not permitted within the warranty period!**

Install a dynamometer on the black string. In case you do not own a dynamometer, you can also use a spring balance with an appropriate weighing range.

Once you have installed the dynamometer (spring balance), pull the string with a force of 350 N (35 kg) and check the position of the lever (pos. 1, figure 11). This lever can be seen in figure 11a. Use the nut on the main shaft (pos. 8, figure 11) to regulate the position of the lever (pos. 1), until the lever is not touching the backrest.

In case you tightened the nut too hard (pos. 8, figure 11) and the lever moved away from the backrest, the necessary axial force on the friction surface of the clutch has been reduced too much.

The winch will not be able to reach to necessary traction force and the friction surface of the clutch will be damaged due to sliding.

## 2. Safety brake

Use a screw (pos. 6) and a lock nut (pos. 7, figure 11) to set the safety brake. First loosen the lock nut and regulate the screw (pos. 6). By turning the screw clockwise, you increase the brake force and by turning the screw anti-clockwise, you decrease the brake force. Then tighten the lock nut which prevents the screw from becoming loose. A proper setting means that the wire rope will not unreel from the drum automatically or too easily. This can lead to wire rope damage when you release the brake and start unreeling the wire rope. The safety brake is set properly when the wire rope can be unreeld without too much effort. In case you are pulling the rope up a slope, it is possible to additionally relieve the brake so that the pulling of the rope is easier. But after you finish the work, the safety brake must be returned to its original position (as describe above).

### 3. Brake

The brake is set via a nut (pos. 5, figure 11). The brake lever (pos. 2) must be in the ON position (figure 10). First use a wrench key to loosen the nut (pos. 4), then turn the nut with a wrench key (pos. 5) to the left to tighten the brake belt. Turn the nut to the right to loosen the brake belt. For optimal operation the gap between the nuts must be 24 mm. If the brake force is not sufficient, repeat the procedure and tighten the nut (pos. 5) to the left. At the end, tighten the nut (pos. 4) to an appropriate gap. If the set braking force is too high, the unreeling of the rope is more difficult. In such cases, turn the nut to the right.

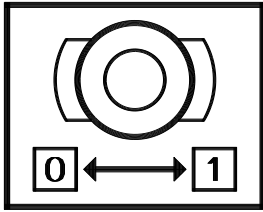

Figure 10

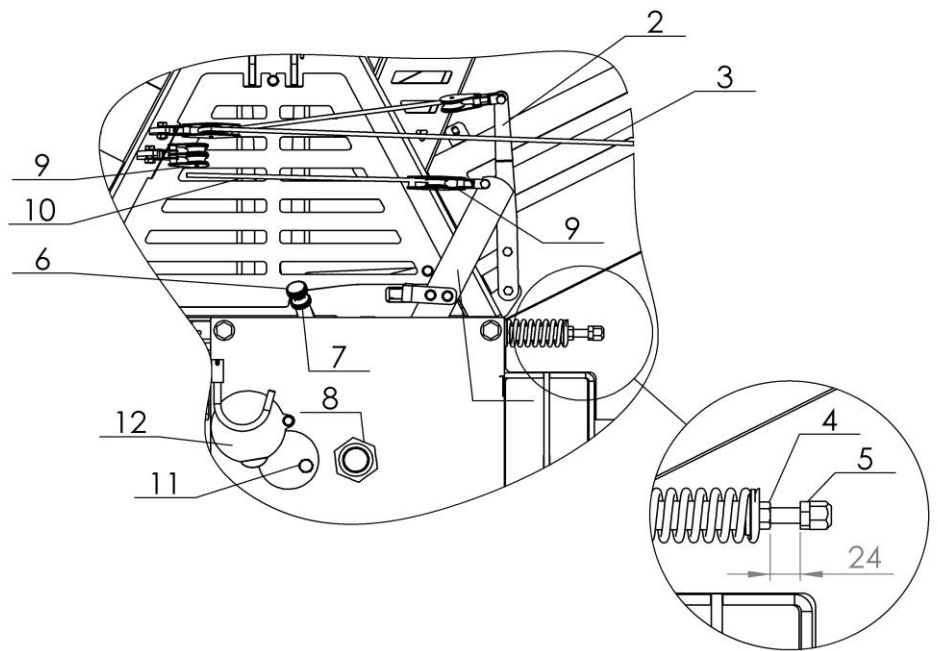

Figure 11

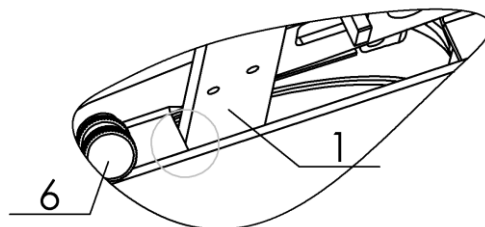

Figure 11a (lever rest)

#### 4. DRIVE CHAIN TENSIONING

After a certain period of operation (10 hours), the drive chain stretches; therefore it must be checked frequently and tensioned, if required. It must be checked every 100 hours of operation. Tensioning is done according to the following procedure (figure 12)! First, disengage the PTO shaft and turn off the engine. Remove the protective sheet of the PTO shaft (pos. 1).

First loosen the nut (pos. 2 and pos. 8, figure 12) with which the lower and upper drive are fixed. Then start tightening the longer chain with a screw (pos. 5). Turn the screw clockwise until you reach the proper tension of the chain. The chain is correctly tensioned when it can still oscillate for 3 to 4 mm in the transverse direction. Tighten the lock nut (pos. 12).

Now tighten the three nuts on the lower drive (pos. 2). Then start tensioning the shorter chain (pos. 7, figure 12). If you have already loosened the four nuts (pos. 8), begin with the turning of the tensioning screw (pos. 10) to the left. This increases the distance between both frames. Beforehand, loosen the lock nut (pos. 11) and re-tighten it when the chains are tensioned.

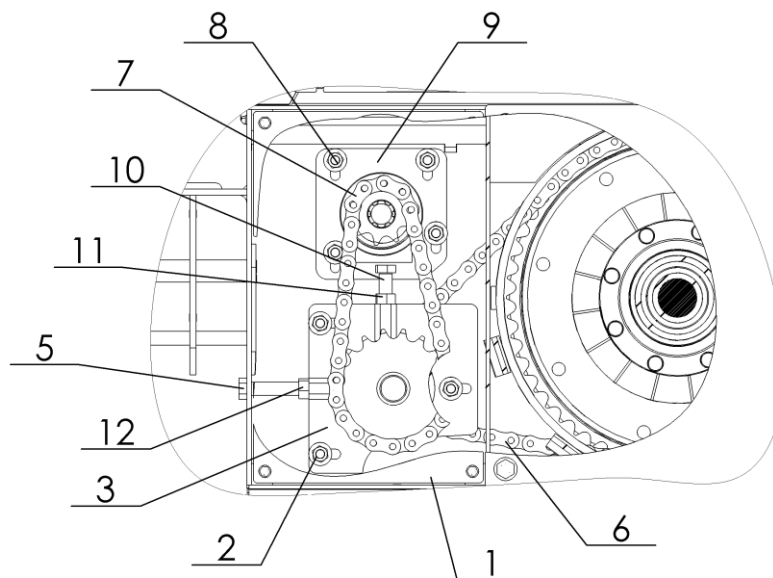
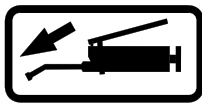

Figure 12

## 5. WIRE ROPE ASSEMBLY

First, remove the triangular protective net on the winch column. Then rotate the cover (pos. 12, figure 11) and rotate the drum in a position, which enables unscrewing of the bolt (pos. 11) on the drum. Insert the wire rope in the guide of the upper pulley and direct it through the upper pulley to the rope drum. Insert the rope in the groove and tighten the bolt (pos. 11, figure 11). Then start to wind according to the procedure, which applies to towing. Once the entire length of the wire rope is wound, unwind it again and wind it again strongly according to the procedure, which is described in the chapter "Wire rope unwinding" to prevent damage to the rope.

## MAINTENANCE LUBRICATION



**Before proceeding with maintenance work, shut down the engine, remove the key and wait for all moving parts to stop.**

There is a grease fitting on the winch, which enables greasing of the upper pulley and guide. The second grease fitting is on the housing of the lower pulley. Greasing is required every 60 hours of operation. The PTO shaft needs to be lubricated according to instructions of the manufacturer.

**Non-frequent greasing can cause wear of slide elements and consequentially a defect, which is not subject to warranty terms!**

Drive chain must be lubricated every 100 hours of operation. Lubricate it with spray for lubrication of chains or special grease, which does not melt at high temperatures, because the grease can come into contact with friction coating of the clutch.

First, remove the cardan shaft protection, which must be fitted back after finishing lubrication. Clean the chain before lubrication. Do not lubricate the part, where the grease can reach clutch with application.

**If grease comes into contact with friction coating of the clutch due do improper and excessive lubrication, this would mean a drastic reduction in pulling force and consequentially it would be required to replace the blades of the clutch, which cannot be a subject of this warranty!**

All other bearings on the winch are of closed type, therefore greasing is not necessary. Grease the PTO shaft according to the instructions of the manufacturer.

## TROUBLESHOOTING

Identified malfunctions (errors)	Cause	Elimination of malfunctions (errors)
<b>Lack of traction force</b>	Grease on the friction surfaces of the clutch	Replace the clutch
	Burned friction surfaces of the clutch	Clean or polish the coating with sandpaper (to a thickness of 0,5 mm)
	The pressure in the hydraulic system is too low (the necessary pressure is 140 bar)	Determine the cause for low voltage
	Worn friction surfaces of the clutch	Replace the clutch
	Incorrectly installed clutch	Install according to technical documentation
<b>Insufficient braking force</b>	Incorrect settings	Set according to instructions for use
	Grease on the brake belt coating	Replace brake belt
	Damaged brake belt	Replace brake belt
	Damaged braking mechanism	Replace damaged parts
	Other	Contact customer service
<b>The wire rope cannot be unreeled or the unreeling is difficult</b>	Incorrect safety brake setting	Set according to instructions for use
	Incorrect brake settings	Set according to instructions for use
	Damaged or stuck wire rope	Unreel the rope with a tractor and if necessary, install new wire rope
	Damaged brake belt	Replace brake belt
	Improper position of the brake lever	Observe the instructions for use
	Damaged or corroded activation mechanism	Grease the activation mechanism with a WD spray or replace the activation mechanism if necessary
	Other	Contact customer service
<b>The winch is pulling although the clutch is turned off</b>	Electromagnetic valve malfunction	Stop work immediately and contact customer service
	Too small clutch clearance	Set according to instructions for use
	Broken part of clutch friction coating	Replace the clutch
	Damaged winch drum	Replace or repair the drum
	Drive belt is too tight	Tension the belt as described in the instructions for use

<b>Winch is very loud during operation</b>	Drive belt is too tight	Tension the belt as described in the instructions for use
	Damaged or worn bearings	Replace bearings



## Spare parts list

### Forestry winches – 65M, 85M (Figure 1)

Pos.	Name	Number of plan or standard			
		65M		85M	
		Nr. of pieces		Nr. of pieces	
1	Frame	1	7001.01.00.0	1	7003.01.00.0
2	Small cover	1	502.11.09.0	1	502.11.09.0
3	Cover	1	702.38.01.0	1	702.38.01.0
4	PTO shaft holder	1	502.11.08.0	1	502.11.08.0
5	Clutch lever	1	7001.05.05.0	1	7001.05.05.0
6	Holder on the lever	1	5002.05.08.0	1	5002.05.08.0
7	Bearing AXK5070	1	120342	1	120342
8	Narrow spacer	1	7001.06.13.0	1	7001.06.13.0
9	Bearing 6310	5	120374	5	120374
10	Wire drum	1	7002.05.00.0 0	1	7004.05.00.00
11	Washer	1	7001.06.14.0	1	7001.06.14.0
12	Discs springs 51x110x2,5	6	702.	6	702.
13	Clutch 1	1	702.23.10.0	1	702.23.10.0
14	Clutch 2	1	702.23.01.A	1	702.23.01.A
15	Freewheel	1	7002.06.01.0	1	7002.06.01.0
16	Wide spacer	1	7001.06.12.0	1	7001.06.12.0
17	Circlip N 110x4	1	101030	1	101030
18	Main shaft+ Screw M12 x 20	1	7002.06.06.0 / 050055	1	7002.06.06.0
19	Support leg	2	7002.15.00.0	2	7002.15.00.0
20	Support leg toggle	2	5006.00.16.0	2	5006.00.16.0
21	Compression spring	2	5006.00.18.0	2	5006.00.18.0
22	Holder	2	5006.00.15.0	2	5006.00.15.0
23	Safety net	1	7006.88.00.0	1	7006.88.00.0
24	Safety net-small	1	7001.00.50.0	1	7001.00.50.0
25	Protection L	1	7001.01.46.0	1	7001.01.46.0
26	Protection D	1	7002.01.45.0	1	7002.01.45.0
27		/	/	/	/
28		/	/	/	/
29		/	/	/	/
30	Brake belt	1	702.61.00	1	704.61.00
31	Brake belt plate	2	7002.05.12.0	2	7002.05.12.0
32	Brake belt pin	1	/	1	/

Poz.	Naziv	Številka načrta ali standarda			
		65M		85M	
		Št. kosov		Št. kosov	
33	Nut M14 Zn	1	030039	1	030039
34	Nut M14 low	1	070080	1	070080
35	Nut M14	1	060390	1	060390
36	Spring mount	2	7001.05.24.0	2	7001.05.24.0
37	Brake spring	1	5002.05.40.0	1	5002.05.40.0
38	Brake tube	1	7001.05.26.0	1	7001.05.26.0
39	Brake belt pin	1	7002.05.14.0	1	7002.05.14.0
40	U holder	1	7002.05.20.0	1	7002.05.20.0
41	Automaton casing	1	5002.02.52.0	1	5002.02.52.0
42	Automaton ball	2	120360	2	120360
43	Automaton axis - long	1	5002.05.59.0	1	5002.05.59.0
44	Automaton axis - short	1	5002.05.55.0	1	5002.05.55.0
45	Automaton spring	1	5002.05.63.0	1	5002.05.63.0
46	Brake lever	2	5002.05.43.0	2	5002.05.43.0
47	Brake handle	1	5002.05.45.0	1	5002.05.45.0
48	Automaton connection	1	7001.05.41.0	1	7001.05.41.0
49	Pin 6 x 30	1	080471	1	080471
50	Pin 6 x 25	2	081143	2	081143
51	Pin 4 x 20	1	080084	1	080084
52	Screw M14 x 30	4	050344	4	050344
53	Screw M12 x 55	1	050427	1	050427
54	Screw M8 x 16	14	050050	14	050050
55	Screw M10 x 70	2	050553	2	050553
56	Screw M10 x 25	2	050193	2	050193
57	Screw M12 x 50	1	050477	1	050477
58	Screw M12 x 45	1	050704	1	050704
59	Screw M8 x 55	2	050041	2	050041
60	Screw M8 x 12	2	050061	2	050061
61	Screw M12 x 65	1	050045	1	050045
62	Nut M12	1	060065	1	060065
63	Nut M8	1	060068	1	060068
64	Washer M10	1	070528	1	070528
65	Washer M8	10	070475	10	070475
66	Washer M14	4	060835	4	060835
67	Nut M10	2	060069	2	060069
68	Nut M50-8ZnX30	1	DIN 934	1	DIN 934
69	Nut M50-8ZnX12	1	DIN 934	1	DIN 934
70	Screw M14 x 280	1	7002.05.23.0	1	7002.05.23.0
71	Screw M6 x 25 + Nut M6	1	?????/?/ 060484	1	DIN 933/ 060484
72	Nut M14	1	060390	1	060390

65M, 85M

-1-

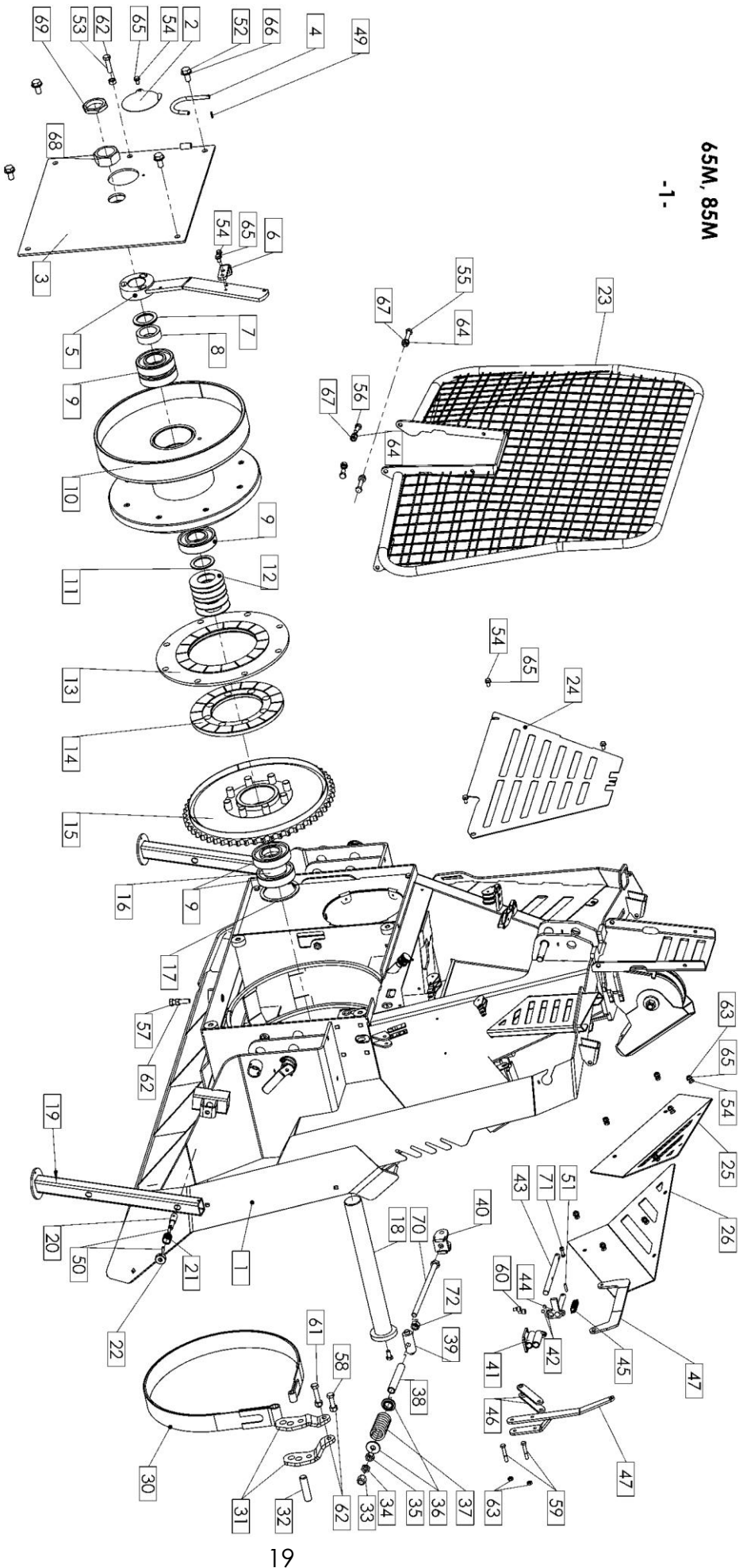

### Forestry winches – 65M, 85M (Figure 2)

Pos.	Name	Number of plan or standard			
		65M		85M	
		Nr. of pieces		Nr. of pieces	
1	Lower pulley frame	1	7002.26.01.0	1	7002.26.01.0
2	Lower pulley protective pin	1	7002.26.08.0	1	7002.26.08.0
3	Lower pulley pin	1	702.57.00.0	1	702.57.00.0
4	Lower pulley axis	1	702.26.07.A	1	702.26.07.A
5	Bearing 6207	2	120111	2	120111
6	Pulley wheel	2	702.25.10.0	2	702.25.10.0
7	Lower pulley	/	/	/	/
8	Upper pin	1	5006.09.00.0	1	5006.09.00.0
9	Circlip Z 35x1,5	1	101066	1	101066
10	Guide bushing	1	5006.09.12.0	1	5006.09.12.0
11	Lower pin	2	502.00.20.0	2	502.00.20.0
12	Rivet 5mm	4	DIN 7337	4	DIN 7337
13	Shaft protection	1	502.35.02.0	1	502.35.02.0
14	Drive cover	1	7002.00.61.0	1	7002.00.61.0
15	Chain 1" 16B1	1	DIN 8187	1	DIN 8187
16	Master link 1" 16B1	1	DIN 8187	1	DIN 8187
17	Shaft with freewheel z = 18	1	7002.08.01.0	1	7002.08.01.0
18	Dowel A 12 x 8 x 28	2	190657	2	190657
19	Bearing 6308	4	120469	4	120469
20	Lower drive frame	1	7002.08.15.0	1	7002.08.15.0
21	Freewheel	1	702.28.03.0	1	704.28.03.0
22	Nut KM/8 M40 x 1,5	2	060102	2	060102
23	Washer MB 8	2	070103	2	070103
24	Entire lower drive	/	/	/	/
25	Longer chain	1	DIN 8187	1	DIN 8187
26	Master link	1	DIN 8187	1	DIN 8187
27	Drive shaft	1	7002.08.65.0	1	7002.08.65.0
28	Upper drive frame	1	7001.08.50.0	1	7001.08.50.0
29	Entire upper drive	/	/	/	/
30	Upper pulley frame	1	7002.25.01.0	1	7004.25.01.0
31	Upper pulley axis	1	7002.25.26.0	1	7002.25.26.0
32	Washer 35-45	4	060826	4	060826
33	Bearing 6207	1	120111	1	120111
34	Upper pulley wire rope guide	1	7002.25.19.0	1	7004.25.19.0
35	Washer 16,5x45x6	1	7002.26.09.0	1	7002.26.09.0
36	Screw M5 x 10	1	051145	1	051145

Poz.	Naziv	Številka načrta ali standarda			
		65M		85M	
		Št. kosov		Št. kosov	
37	Magnet 36 x 7	1	/	1	/
38	Spring	1	5006.10.12.0	1	5006.10.12.0
39	Locking screw M12	1	DIN 906	1	DIN 906
40	Guard	1	5006.10.11.0	1	5006.10.11.0
41	Spring pin 6 x 15	2	081126	2	081126
42	Spring pin 10 x 55	2	801128???	2	801126???
43	Spring pin 6 x 45	1	080086	1	080086
44	Pin holder	1	5006.10.10.0	1	5006.10.10.0
45	Spring fuse 10 + small chain	1	DIN 914	1	DIN 914
46	Spring fuse 8 + small chain	2	DIN 914	2	DIN 914
47	Hitch	1	5006.12.00.0	1	5006.12.00.0
48	Hitch pin	1	702.56.03.0	1	702.56.03.0
49	Hitch guard	1	7002.00.20.0	1	7002.00.20.0
50	Single pulley	1	502.00.40.1	1	502.00.40.1
51	Double pulley-wide ear	1	502.00.43.0	1	502.00.43.0
52	Single pulley-narrow ear	1	502.00.42.1	1	502.00.42.1
53	Double pulley-narrow ear	1	502.00.43.0	1	502.00.43.0
54	String-red	1	/	1	/
55	String-black	1	/	1	/
56	Screw M8 x 20	4	050051	4	050051
57	Adjusting screw	1	5006.05.37.0	1	5006.05.37.0
58	Lock nut	1	5006.05.38.0	1	5006.05.38.0
59	Compression spring	1	5006.05.36.0	1	5006.05.36.0
60	Safety brake pin Ø 14	1	/	1	/
61	Screw M12 x 80	2	050046	2	050046
62	Screw M12 x 50	2	050391	2	050391
63	Screw M12 x 140	2	051157	2	051157
64	Screw M12 x 120	2	050402	2	050402
65	Screw M16 x 100	1	051148	1	051148
66	Nut M12	7	060065	7	060065
67	Nut M16	2	060066	2	060066
68	Washer M12	7	070393	7	070393
69	Screw M16 x 80	1	DIN 933???	1	DIN 933
70	Grease nipple M8	1	090087	1	090087
71	Nut M8	4	060068	4	060068

65M, 85M

-2-

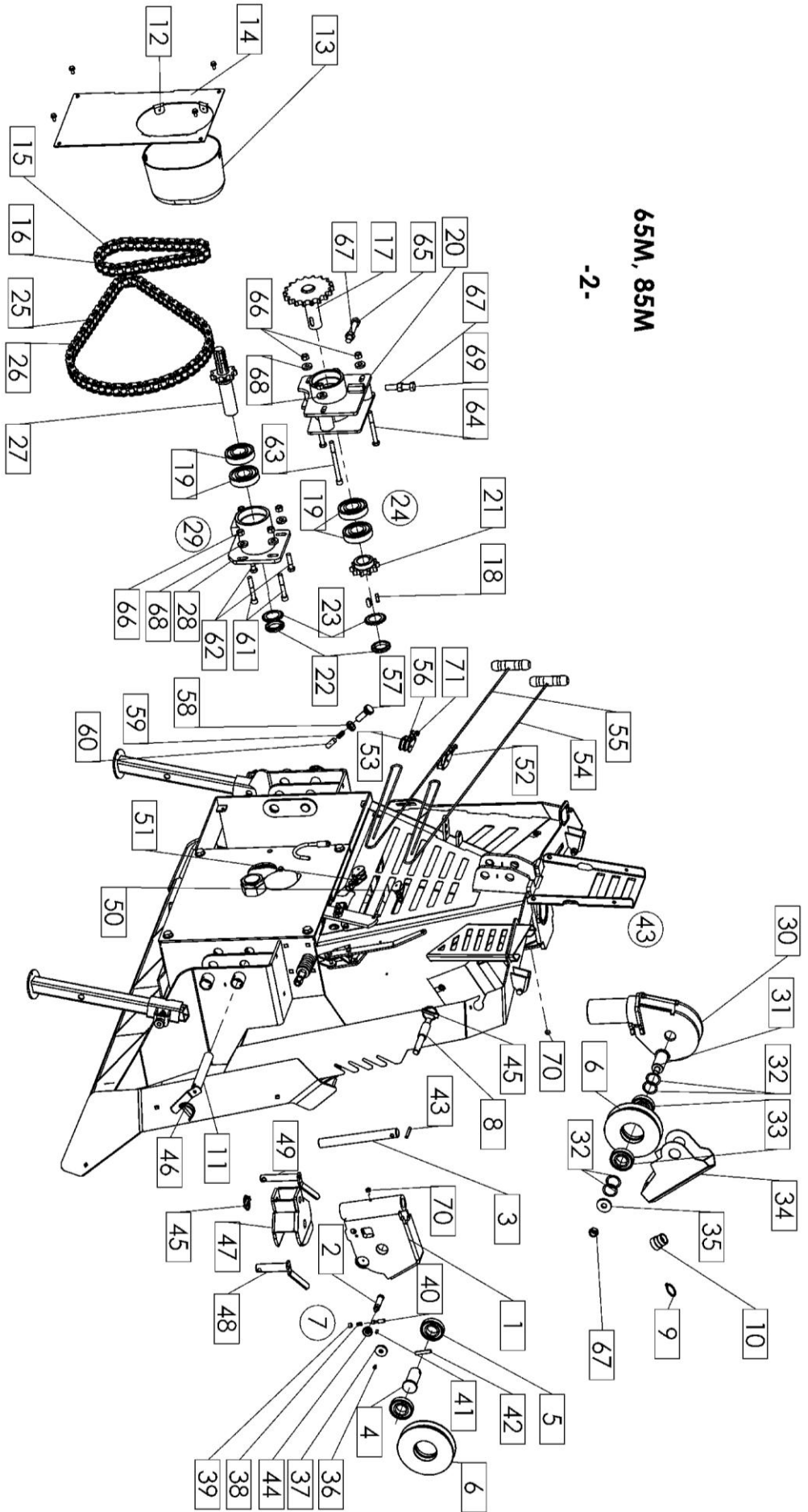

## **EC – Declaration of conformity**

In accordance with EC guideline 2006/42/EC and  
Regulation on machine safety (Ur.list RS, št.75/08)

we

**UNIFOREST d.o.o.**

Dobriša vas 14a,  
3301 PETROVČE, SLOVENIA

declare with full responsibility that the following product:

**WINCH:  
UNIFOREST 65M / 85M**

**Serial number:**\_\_\_\_\_

meets the basic safety and health requirements of EC guideline 2006/42/EC  
and Regulation on machine safety (Ur.list RS, št.75/08)

For appropriate enforcement of relevant safety and health requirements  
of EC guidelines, the following standards and/or technical regulations were  
applied:

EN ISO 12100-1/2003 EN ISO 12100-2/2003 EN 294/1992 EN 349/1993  
EN ISO 4254-1/2005 EN 982/1996 ÖNORM L5276/ 1998

Petrovče, 05.04. 2012

Drago Pintar, BE

**UNIFOREST**  
d.o.o. 1  
Dobriša vas 14, SI-3301 PETROVČE