

## Intake Manifold Pressure Sensor (019-061)

### Remove

Slide the locking tab on the top side of the connector to the unlock position.

Press down on the tab near the end of the harness connector where the harness wires lead into the connector.

Pull outward on the connector away from the sensor to disconnect.

Use a socket or combination wrench to remove the sensor.

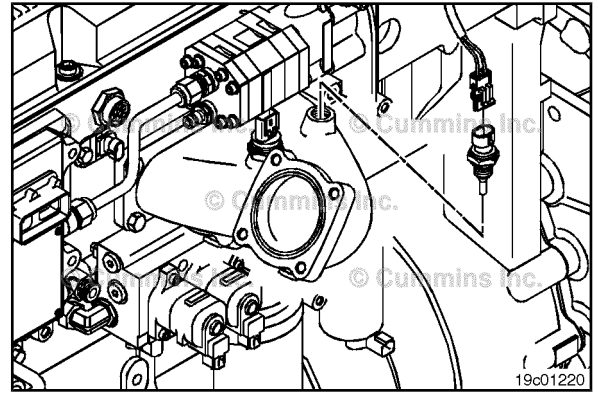

### Inspect for Reuse

The sensor is located on the intake air horn. Use the electronic service tool to monitor the sensor.

To validate this reading, a multimeter with a pressure transducer can be used to measure the pressure.

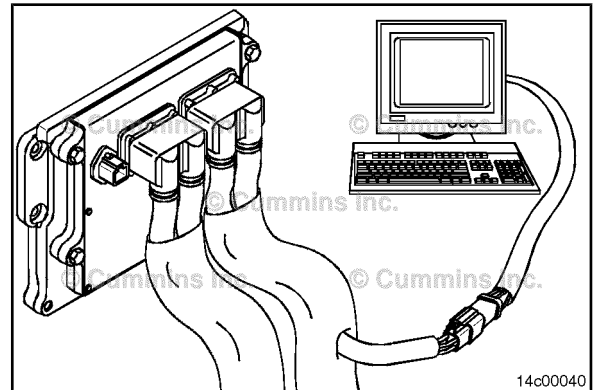

### Install

Install the sensor and tighten the capscrew.

**Torque Value:** 14 N•m [ 124 in-lb ]

Connect the wiring harness connector to the sensor and slide the locking tab to the lock position.

Turn the keyswitch ON.

Use the electronic service tool to monitor the intake manifold pressure sensor to ensure it is working correctly.

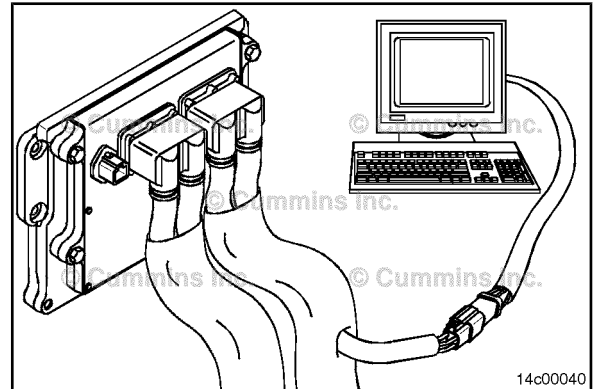

## Key Switch Battery Supply Circuit (019-064)

### Voltage Check

The vehicle keyswitch supplies an input signal to the electronic control module (ECM), which turns the ECM on or off.

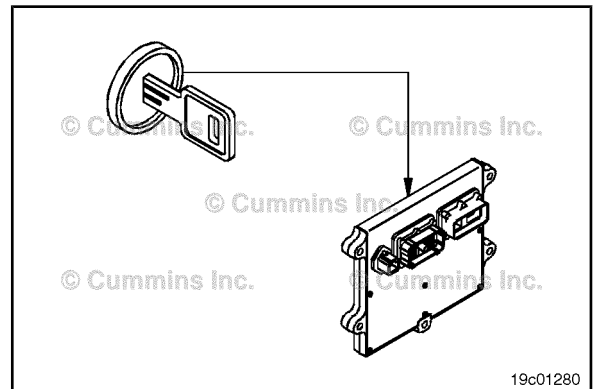

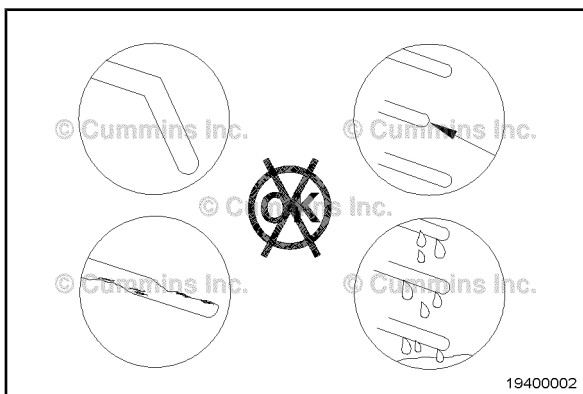

Turn the keyswitch to the OFF position.

Disconnect the OEM harness connector from the ECM.

Inspect the connector pins.

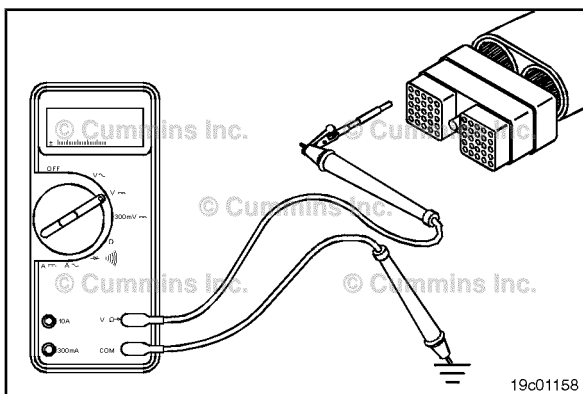

### ⚠CAUTION⚠

To reduce the possibility of pin and connector damage, use test lead Part Number 3822758, when taking a measurement. The leads must fit tightly in the connector without expanding the pins in the connector.

Adjust the multimeter to measure VDC.

Insert a test lead into the keyswitch input signal pin of the original equipment manufacturer (OEM) harness connector. Connect the lead to the multimeter probe.

Touch the other probe to a clean, unpainted surface on the engine block ground.

Turn the keyswitch to the ON position.

The measured voltage **must** show battery voltage. If the measured voltage is more than 0.5 VDC below battery voltage, continue with the next step.

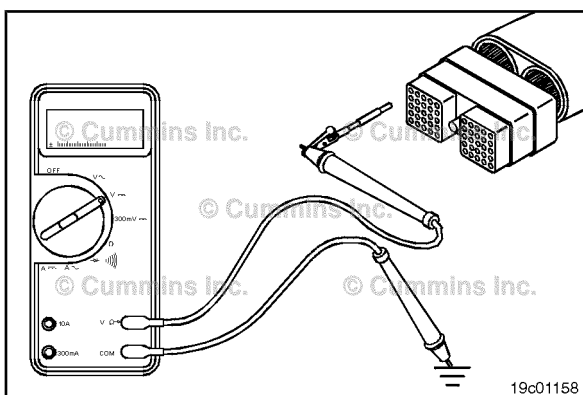

Disconnect the bulkhead connector.

Inspect the connector pins. Refer to the OEM troubleshooting and repair manual for the proper procedure.



Measure the voltage. Refer to the OEM troubleshooting and repair manual for the proper procedure.



The measured voltage **must** show battery voltage. If the voltage is **not** correct, there is a problem with the OEM harness wire, keyswitch, or battery connection.



Repair or replace the OEM harness, keyswitch, or check the battery connections. Refer to the OEM troubleshooting and repair manual for the proper procedures.

**NOTE:** On vehicles equipped with Eaton ultra shift transmissions, a momentary engine ignition interrupt relay is installed in the OEM keyswitch circuit. If the measured voltage is **not** correct, the momentary engine ignition interrupt relay could possibly have failed. Refer to Eaton troubleshooting and repair Instructions for diagnosing this relay at <http://www.roadranger.com/litcenter/litcenter.htm>.

## Engine Oil Pressure Sensor (019-066) Remove



Disconnect the engine wiring harness from the engine oil pressure sensor.

Remove the engine oil pressure sensor.

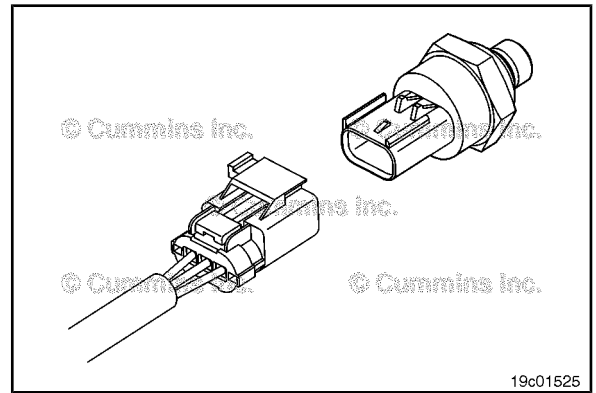

## Test

Connect the electronic service tool to the datalink.

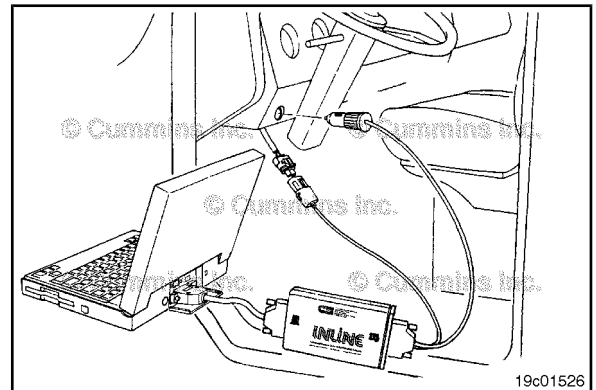

Connect the engine harness to the lubricating oil pressure sensor.

Leave the sensor suspended from the harness.

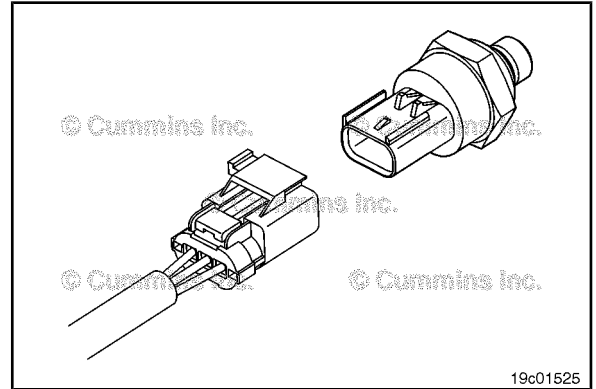

Monitor the lubricating oil pressure with the electronic service tool.

The lubricating oil pressure sensor **must** be within  $\pm 17.2$  kPa [2.5 psi] of zero.

If the lubricating oil pressure sensor is **not** within specifications, the lubricating oil pressure sensor **must** be replaced.

Disconnect the lubricating oil pressure sensor from the engine harness.

Disconnect the electronic service tool.

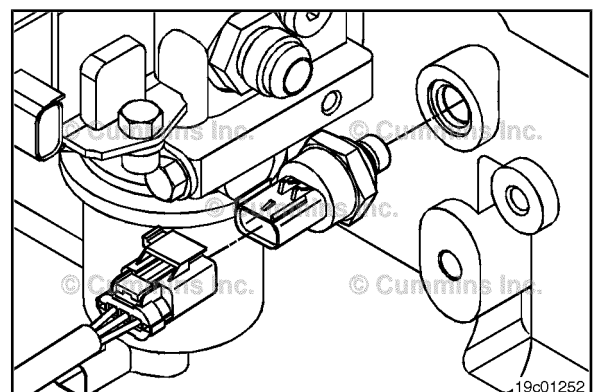

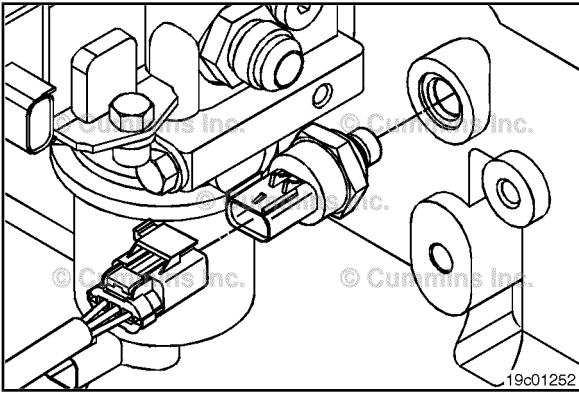

### Install

Verify the o-ring is installed on the sensor.



Install the engine oil pressure sensor.

**Torque Value:** 23 N•m [ 17 ft-lb ]



Connect the engine wiring harness to the engine oil pressure sensor. An audible click will be heard when the connector locks in place.

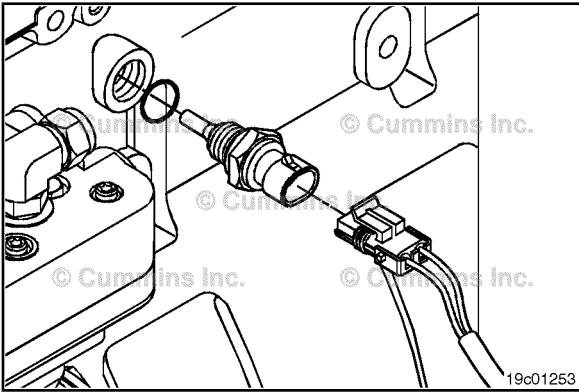

### Engine Oil Temperature Sensor (019-067)

#### Remove

Disconnect the engine wiring harness from the engine oil temperature sensor.

Remove the engine oil temperature sensor.

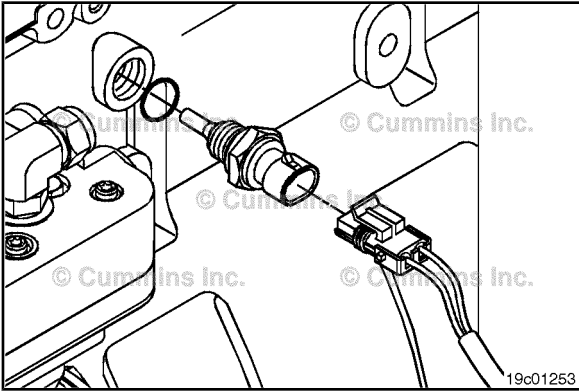

### Install

Verify the o-ring is installed on the sensor.



Install the engine oil temperature sensor.

**Torque Value:** 23 N•m [ 17 ft-lb ]



Connect the engine wiring harness to the engine oil temperature sensor. An audible click will be heard when the connector locks in place.



### OEM Wiring Harness (019-071)

#### General Information

The OEM harness is supplied and installed by the vehicle manufacturer. Follow the vehicle manufacturer's procedures, if replacement is necessary. Refer to the vehicle manufacturer's troubleshooting and repair manual.

There is **no** traditional 31-pin connector. The ECM connects to the OEM components directly from the OEM harness and OEM port on the ECM (50-pin).

## Remote PTO Switch Circuit (019-079) Resistance Check

### ⚠CAUTION⚠

Do not use probes or leads other than Part Number 3822758. The connector will be damaged. The leads must fit tightly in the connector without expanding the pins in the connector.

Disconnect the OEM harness connector from the ECM.

Insert a test lead into the remote PTO switch return pin of the OEM harness connector and connect it to the multimeter probe. Insert the other test lead into the remote PTO switch signal pin of the connector and connect it to the other probe.

Make sure the switch is connected to the circuit. Move the remote PTO switch to the ON position. Measure the resistance with the multimeter. The multimeter **must** show a closed circuit (10 ohms or less). If the circuit is **not** closed, inspect the switch return wire and the remote PTO switch signal wire for an open circuit. Repair or replace the OEM harness, provided the switch has been previously checked. Refer to the OEM troubleshooting and repair manual for the procedures.

If the resistance is correct, the remote PTO switch return wire and the remote PTO switch signal wire **must** be checked for a short circuit to ground, a short circuit from pin to pin, and a short circuit to an external voltage source. Connect all components after the repair is complete.

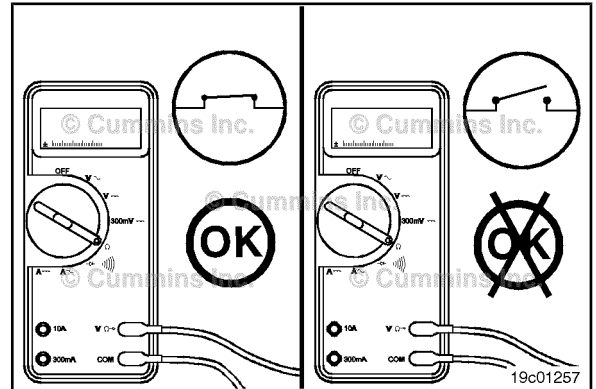
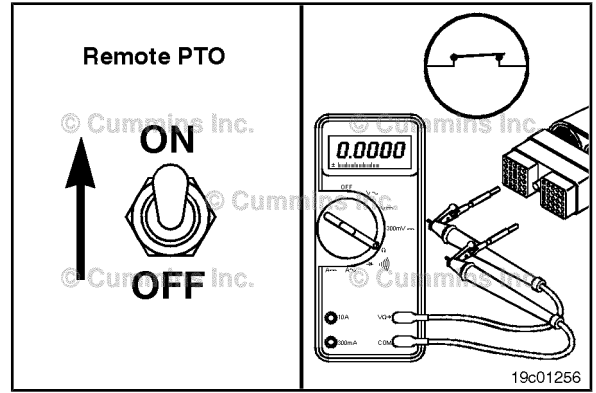

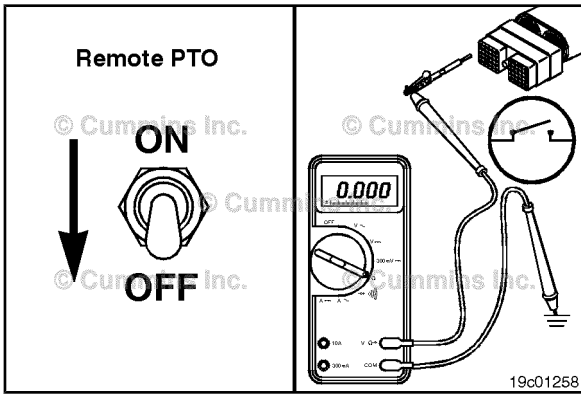

### Check for Short Circuit to Ground



**Do not use probes or leads other than Part Number 3822758. The connector will be damaged. The leads must fit tightly in the connector without expanding the pins in the connector.**

Disconnect the OEM harness from the ECM.

Insert the test lead into the remote PTO switch signal pin in the OEM harness connector and connect it to the multimeter probe. Touch the other probe to engine block ground.

With the remote PTO switch in the OFF position, read the resistance.

The multimeter **must** show an open circuit (100k ohms or more).

If the resistance values are **not** correct, make sure the remote PTO switch signal wire and the ground wire are properly installed on the switch. If both wires are correctly installed, inspect the wires for a short to ground circuit, provided the remote PTO switch has been previously checked.

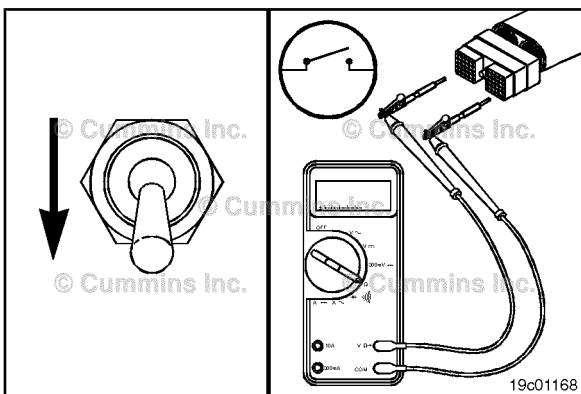

### Check for Short Circuit from Pin to Pin

Check for a short circuit from pin to pin. Set the remote PTO switch to the OFF position. Insert the test lead into the remote PTO switch return pin of the OEM harness connector and connect it to the multimeter probe. With a test lead connected to the other multimeter probe, check all the other pins in the connector. Measure the resistance. The multimeter **must** show an open circuit (100k ohms or more).

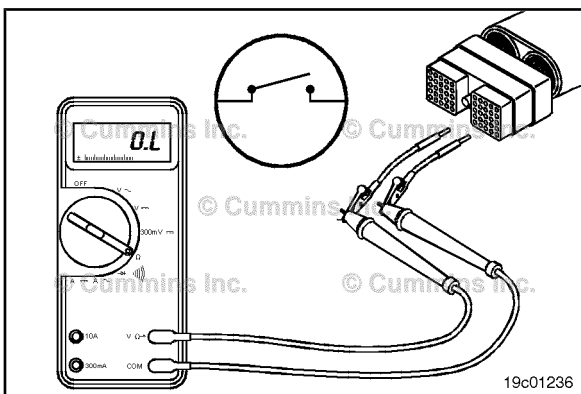

Remove the lead from the remote PTO switch return pin and insert it into the remote PTO switch signal pin of the harness connector. With the other test lead, check all other pins in the connector. Measure the resistance. The multimeter **must** show an open circuit (100k ohms or more).

If the circuit is **not** open, there is a short circuit between the switch circuit and any pin that did **not** measure an open circuit, provided the switch has previously been checked. Repair or replace the wires in the OEM harness according to the vehicle manufacturer's procedures.

Connect all components after completing the repair.

## Remote PTO Switch (019-080) General Information

A remote PTO switch is available for applications where PTO operation control is desired away from the operator controls.

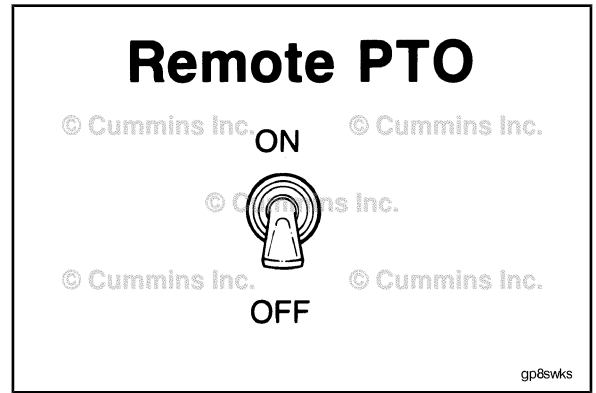

The remote PTO switch circuit consists of the remote PTO switch, remote PTO switch signal wire and a remote PTO switch return wire.

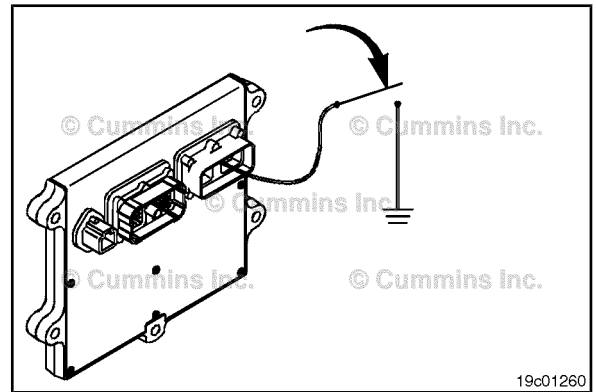

## Resistance Check

Locate the remote PTO switch.

Remove and tag the two connectors from the terminals on the switch.

Touch the multimeter probes to the terminals on the switch.

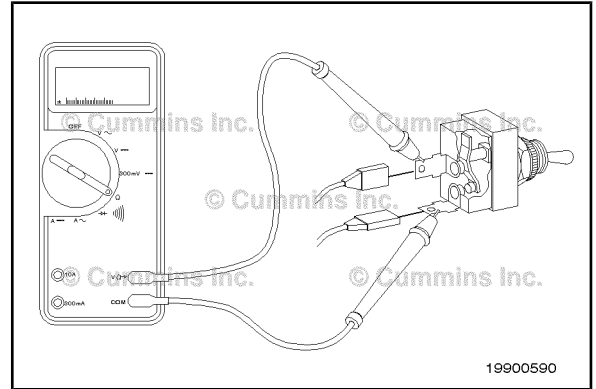

Move the switch to the OFF position and measure the resistance. The multimeter **must** show an open circuit (100k ohms or more). If the circuit is **not** open, the switch has failed.

Replace the switch. Refer to the OEM troubleshooting and repair manual for the replacement procedures.

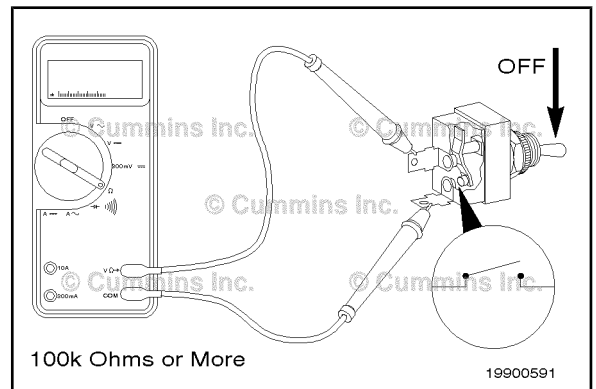

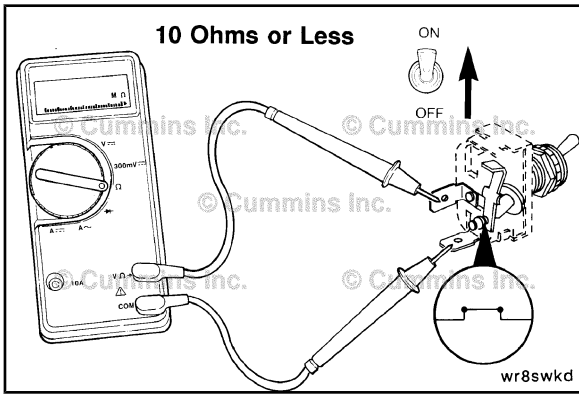

Move the switch to the ON position and measure the resistance. The multimeter **must** show a closed circuit (10 ohms or less). If the circuit is **not** closed, the switch has failed.



Replace the switch. Refer to the OEM troubleshooting and repair manual for the replacement procedures.

If the resistance value is correct, the switch **must** still be checked for a short circuit to ground.

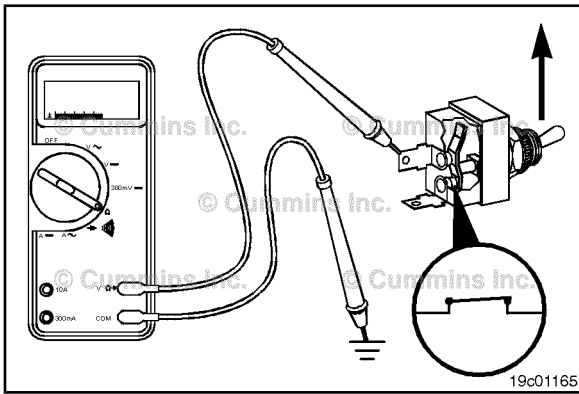

### Check for Short Circuit to Ground



Touch one of the multimeter probes to one of the switch terminals. Touch the other probe to chassis ground. Move the switch to the ON position and measure the resistance. The multimeter **must** show an open circuit (100k ohms or more). If the circuit is **not** open, the switch has failed. Replace the switch. Refer to the OEM troubleshooting and repair manual for replacement procedures. If the switch passes all of the previous checks, the circuit **must** be checked for an open circuit, a short circuit to ground, a short circuit from pin to pin, and a short circuit to an external voltage source.

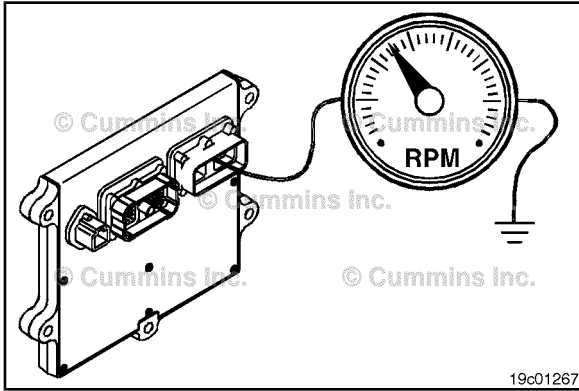

### Tachometer Circuit (019-083) General Information

The ECM can supply an output signal to operate the vehicle tachometer.

The circuit is the tachometer signal wire and a return line in the OEM harness.

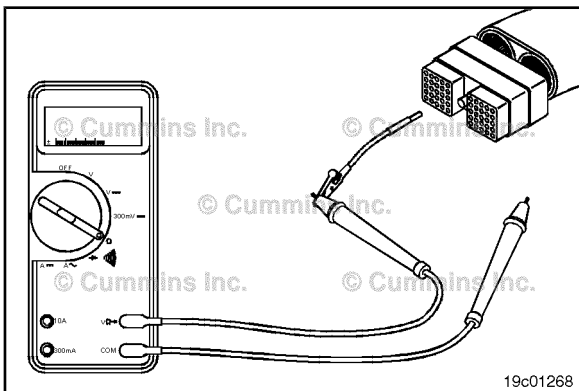

### Resistance Check



**Do not use probes or leads other than Part Number 3822758. The connector will be damaged. The leads must fit tightly in the connector without expanding pins in the connector.**

Disconnect the OEM harness from the ECM. Disconnect the tachometer from the OEM harness.

Insert the test lead into the tachometer signal pin of the OEM harness connector and connect it to the multimeter probe.



Locate the tachometer connector of the OEM harness.

Connect the other lead to the multimeter probe and connect it to the tachometer signal pin of the tachometer connector that is coming from the engine ECM. Consult the OEM troubleshooting and repair manual for wiring schematics.

Adjust the multimeter to the resistance setting. Measure the resistance.

The multimeter **must** show a closed circuit (10 ohms or less). If the circuit is **not** closed, there is an open circuit or the wires in the tachometer connector are reversed. Repair or replace the wire connected to the tachometer signal pin in the OEM harness according to the vehicle manufacturer's procedures.

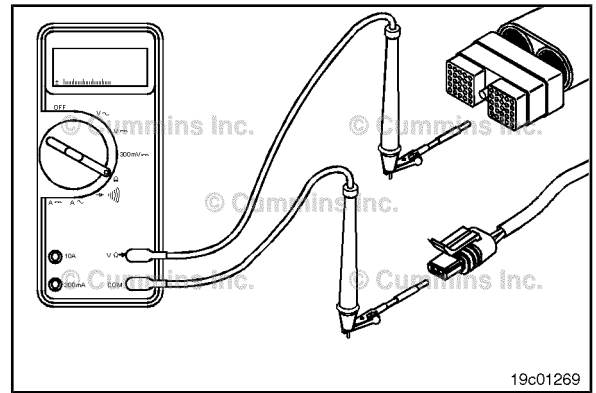

19c01269

### Check for Short Circuit to Ground

Disconnect the tachometer from the OEM harness.

Insert the test lead into the tachometer signal pin of the OEM harness connector and connect it to the multimeter probe. Touch the other multimeter probe to the engine block ground. Measure the resistance.

The multimeter **must** show an open circuit (100k ohms or more).

If the circuit is **not** open in either of the prior checks, repair the wires which have incorrect readings. Refer to the OEM troubleshooting and repair manual for the repair procedures.

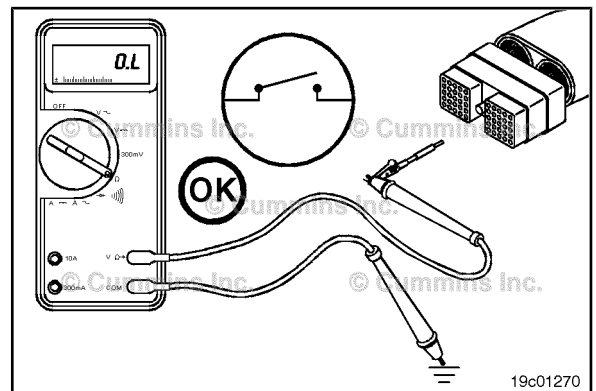

19c01270

### Check for Short Circuit from Pin to Pin

Disconnect the tachometer from the OEM harness. Insert the test lead into the tachometer signal pin of the OEM harness connector and connect it to the multimeter probe. Insert the other lead into any pin, except the tachometer switch return, of the OEM harness connector, and connect it to the other multimeter probe, and measure the resistance.

The multimeter **must** show an open circuit (100k ohms or more).

Measure the resistance from the tachometer signal pin to all other pins in the OEM connector. The multimeter **must** show an open circuit.

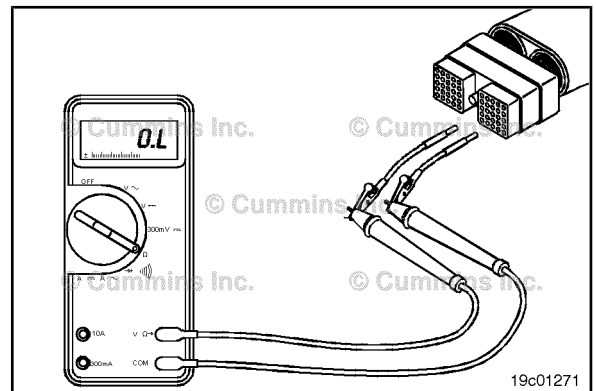

19c01271

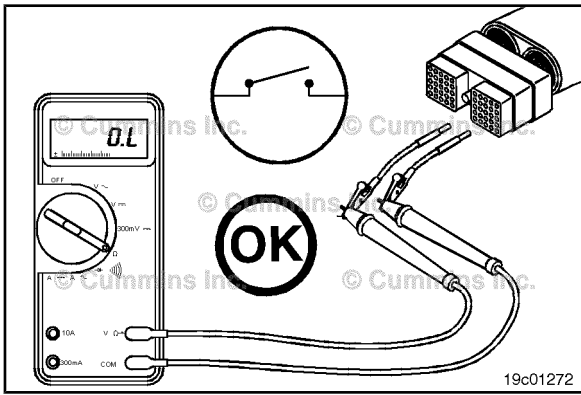

Remove the test lead from the last tested pin, insert it into the tachometer switch return pin. Measure the resistance from the tachometer switch return pin to the tachometer signal pin in the OEM harness connector.

The multimeter **must** show an open circuit (100k ohms or more) at all pins. If any pin-to-pin check measures as **not** open, there is a short circuit between the tachometer signal pin and any other pin that measured a **not** open circuit. Repair or replace the OEM harness. Refer to Procedure 019-250 for harness repair or Procedure 019-071 for harness replacement.

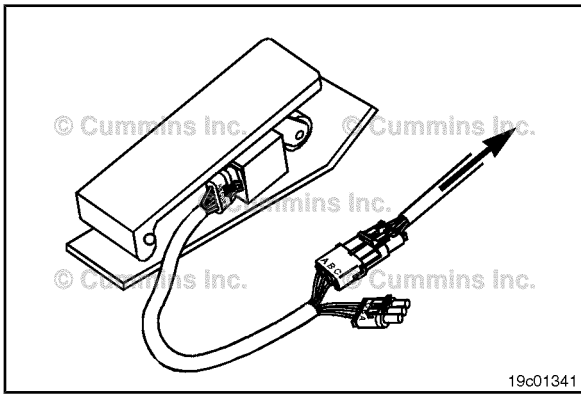

## Accelerator Pedal or Lever Position Sensor (019-085)

### General Information

The accelerator pedal or lever position sensor will vary with OEM. Refer to the vehicle manufacturer's manual for the specific troubleshooting and repair procedures. This section contains troubleshooting and repair procedures for one typical accelerator pedal or lever position sensor.

The accelerator pedal or lever position sensor sends a signal to the ECM when the operator pushes on the accelerator pedal or lever. The accelerator position circuit consists of the accelerator pedal or lever position sensor, the ECM, accelerator pedal/lever position +5 volt, accelerator pedal/lever position signal, and accelerator pedal/lever position return wires.

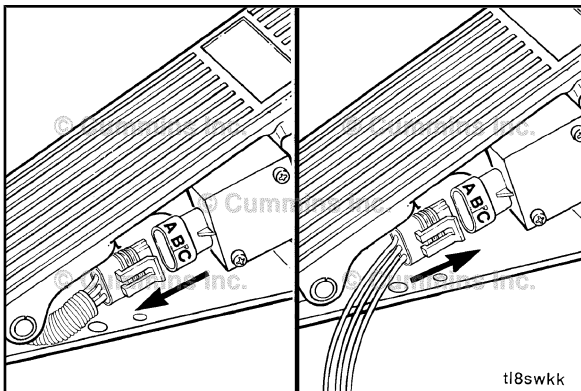

### Resistance Check

If INSITE™ is available, monitor the accelerator position sensor for proper operation. If **not**, follow the troubleshooting procedures in this section.

Disconnect the 3-pin connector from the accelerator position sensor.

Connect the test connector.