

# ProtaStructure® 2018

## Integrated Analysis and Design Solution for Building Systems

- › Multi-material modelling using RC and Steel structural members
- › Quick and intuitive project creation
- › State-of-the-art structural model and advanced analysis methods
- › Economical and reliable design
- › Fully automated detailing
- › BIM Integration for project coordination

---

**ProtaStructure** is an innovative solution for structural engineers to model, analyze and design buildings quickly and accurately.

From one central model, easily compare different schemes and automate your steel and concrete design, significantly reducing project delivery time.

Produce high quality drawings and all design documentation from **ProtaStructure** automatically using included **ProtaDetails** and **ProtaSteel**. Seamlessly coordinate projects with intelligent BIM integration.

**ProtaStructure** saves time and increases business profitability.

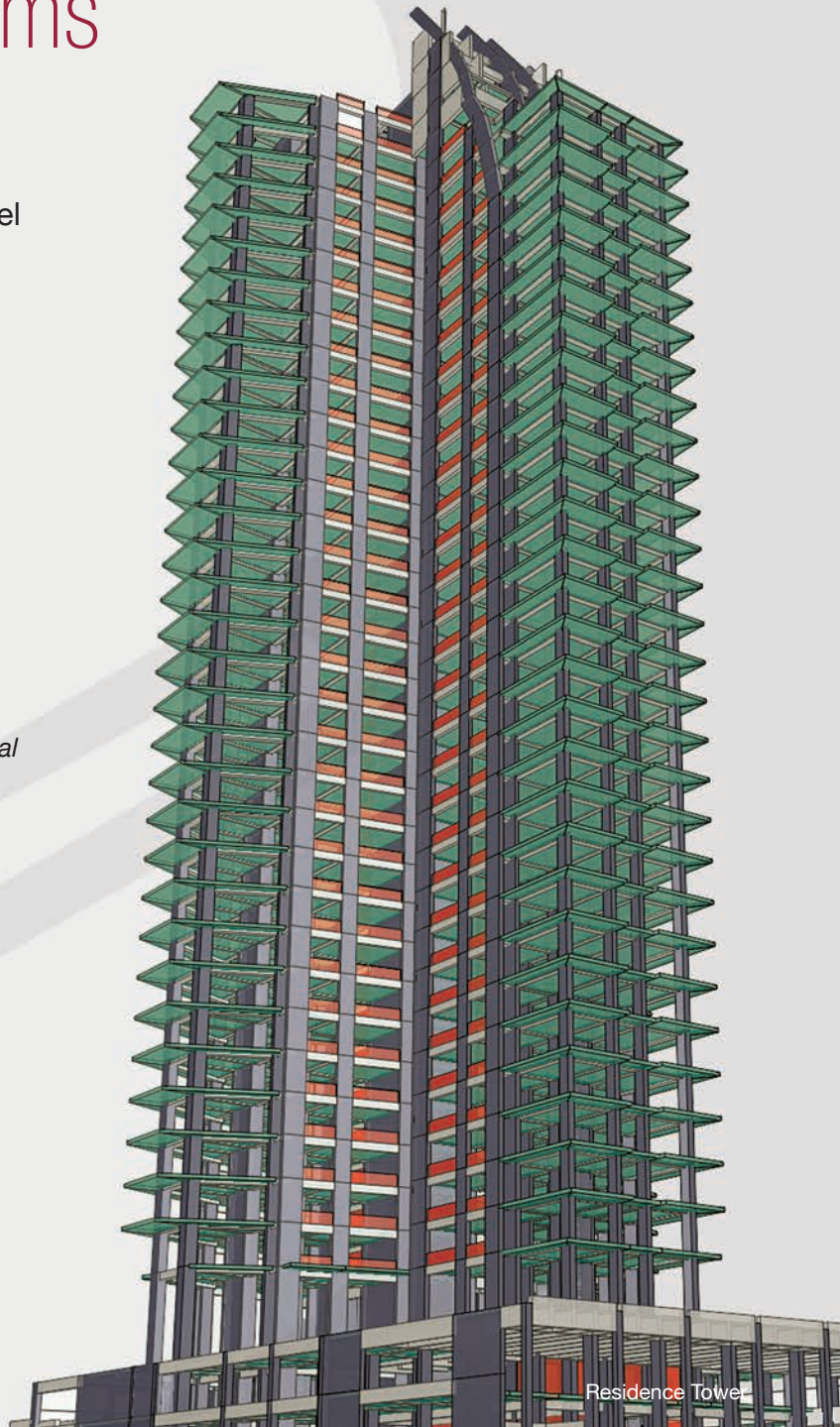

# At First Glance

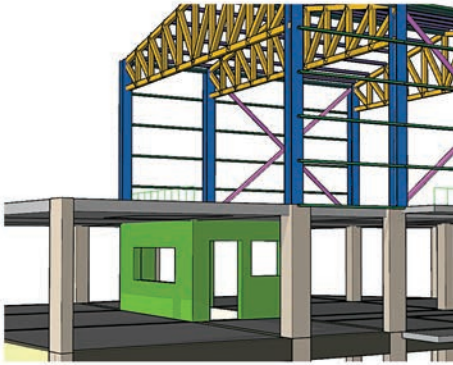
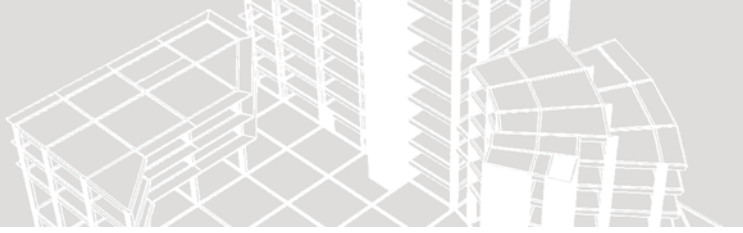

- › Fast project delivery with fully integrated Concrete and Steel design from one central model.
- › **Easy, quick and intuitive** modelling with **Multiple Window Views** and **Dynamic Input**.
- › **3D finite element analysis** with **state-of-the-art analytical model** with extensive analysis options and shell element support for floors and shearwalls.
- › Advanced analysis techniques including vertical and lateral elastic analysis, Equivalent Static Earthquake Load, Response Spectrum Analysis, Time-History, Pushover, Staged Construction, P-Delta, Temperature difference and Seismic Isolators.

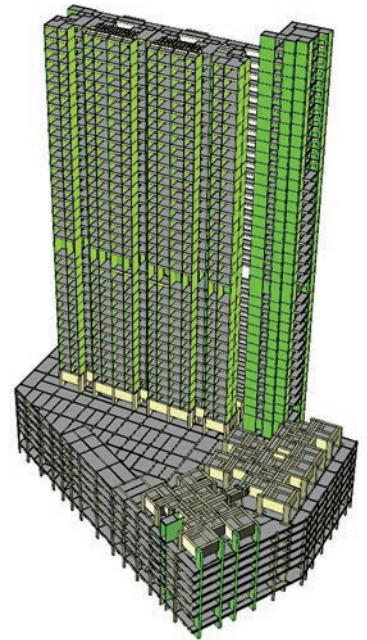

Offices and Shopping Mall

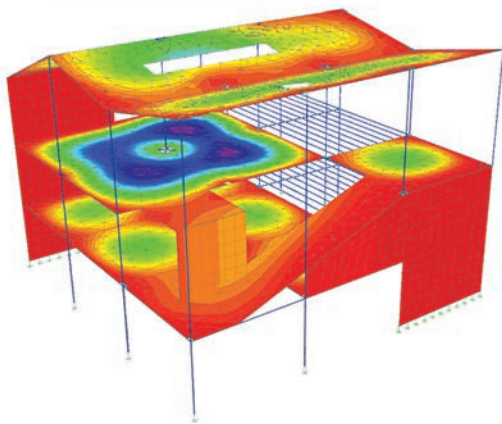

- › Analysis and design to a range of **international codes** including **specialist Seismic requirements**.
- › Seismic assessment and retrofitting of existing buildings using force based **elastic method** and **nonlinear pushover analysis**.
- › Fully automated **RC detailing** into your drawing sheets. **Manual drafting** using smart rebars. Change management and dynamic quantity tables together with fast engineering macros including **retaining wall, stair, pile analysis and design** and detailing.
- › Automated and user-defined **steel connections**, full engineering drawings together with comprehensive **part numbering** and **shop detailing for fabrication**.
- › Bi-directional integration of RC and Steel models with leading **BIM (Building Information Modelling)** platforms including Autodesk Revit and Tekla Structures.

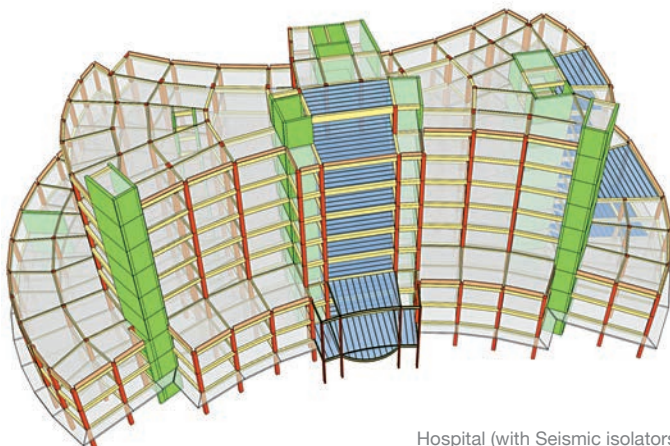
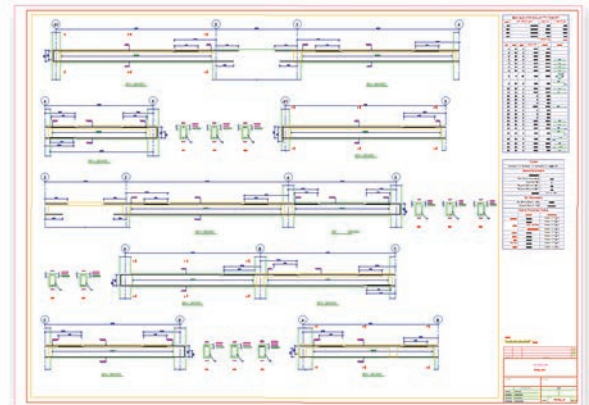
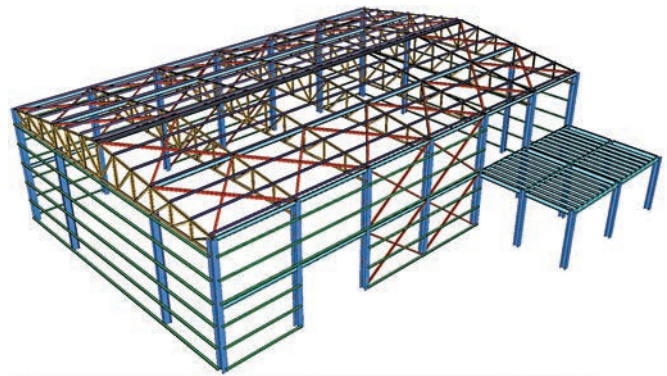

Hospital (with Seismic isolators)

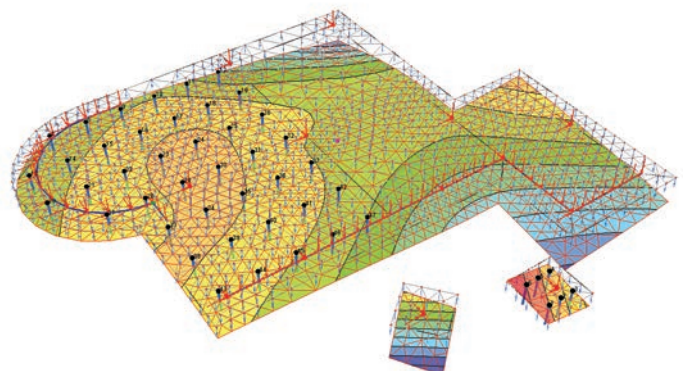

# Modelling

With its structural modelling tools, **ProtaStructure** allows **RC, Steel and Composite** structural members to be **easily, quickly and intuitively** defined in one model

- Quickly model structural steel elements including **truss, purlin, brace, girt** with flexible parametric macros. Specify your **splice locations** on steel columns, beams and trusses.
- Merging different models together allowing rapid project creation.
- Fast generation of multiple storeys with **similar storey** feature.
- Import setout including gridlines, columns and shearwalls directly from architectural drawings.

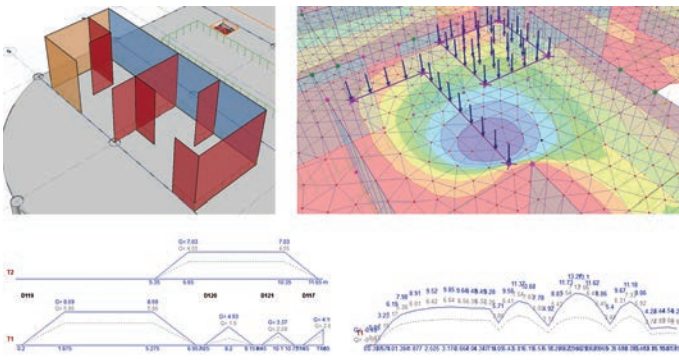

- Create **Arc** and **multi-segment** axes/beams, **sloping members** and structures with non-orthogonal plans.
- Easy model **shearwalls** and custom shaped **corewalls** with or without **openings**.
- Define conventional, waffle, precast and flat slabs with **curved** and **irregular** edges.
- Anchor** fixed column and beam positions to corners and edges. When section sizes change, anchored positions are retained.
- Model **sloping slabs, beams, columns** and **shearwalls** easily using plane definitions.
- Assign flexible user-defined supports including springs under columns and shearwalls.
- Apply user-defined **Point Loads, Moments** and **Span Loads** to columns and shearwalls.
- Automatically decompose loads from plate, ribbed and waffle slabs, using **Yield Lines** and/or **Finite Elements Methods**. Apply point, line and patch loads to slabs.
- Check model loads, finishes, elements sizes and properties using color coded visual interrogation.

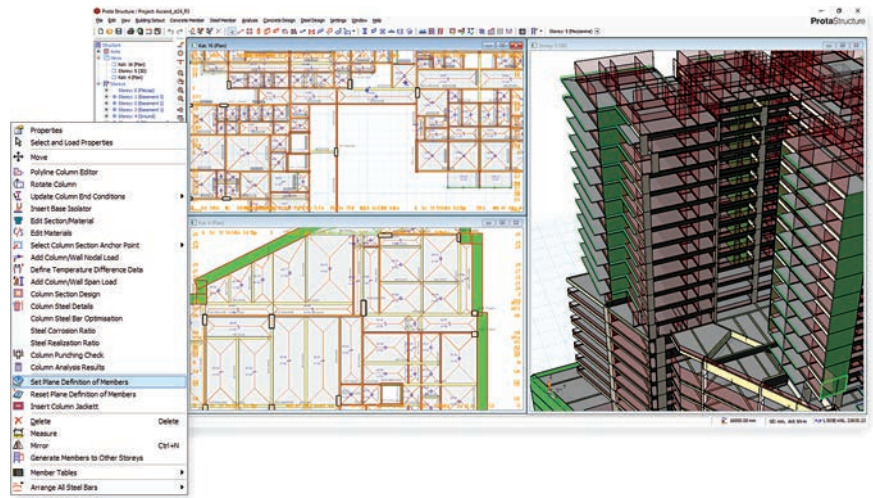

- Simultaneously work on different floor plans and 3D model with **multiple window system**. Easy access to parts of model by using different **Filters** and **Visual Interrogation**.
- Use interactive insertion, move and rotation commands using **Dynamic Data Input System**.
- Define different materials and reinforcement steel grades **on floor and element basis** throughout the project.

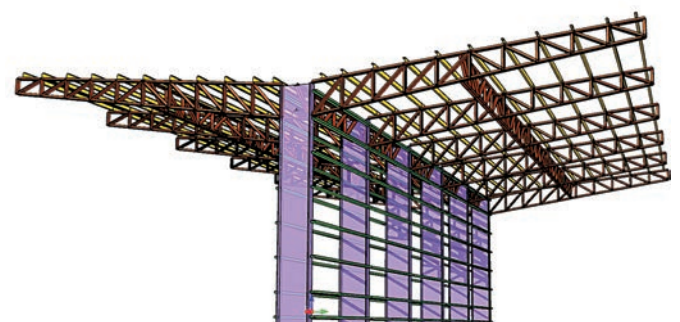
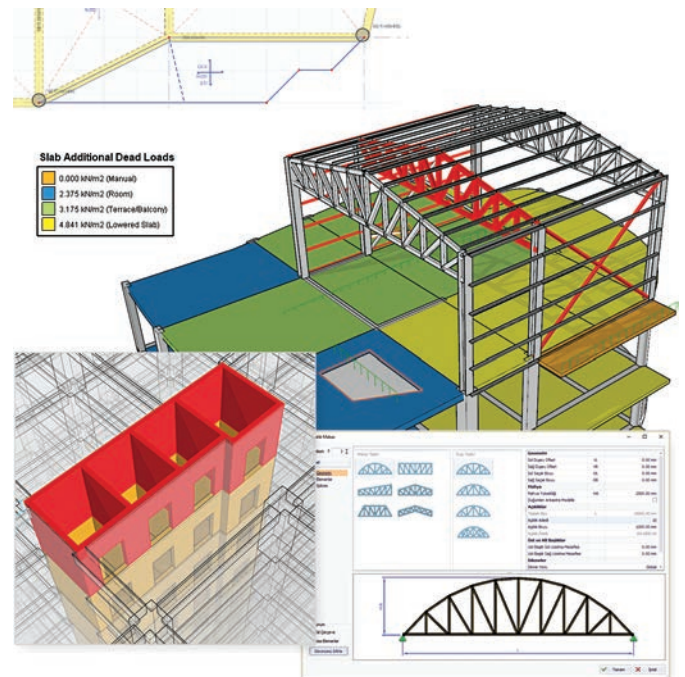

# Analysis

Structural analysis is performed by specifically developed 3D finite element solver and state-of-the-art analytical model.

- › State-of-the-art **3D finite element model** and solver.
- › Rapid analysis using multi-cores and pre-processing technology.
- › Analysis of slab systems independently or **integrated with the structure** by using finite elements.
- › Storey-based definition of **rigid/semi-rigid (meshed) diaphragms** with option to ignore diaphragm action for particular slabs.
- › Automatic **rigid links, rigid zones** and **asymmetrical end-releases** on frame members.
- › Analysis of shearwalls and custom shaped corewalls with or without openings using **shell elements, mid-pier** and **single-pier** models.
- › **Staged Construction Analysis** with detailed options, **P-Delta** analysis and definition of equal/gradient **temperature differences**.

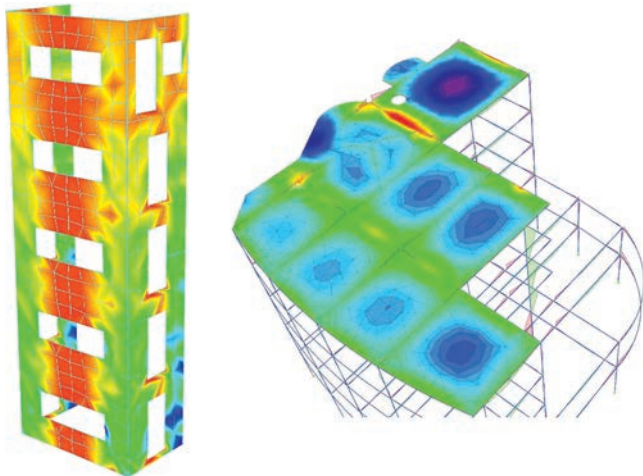
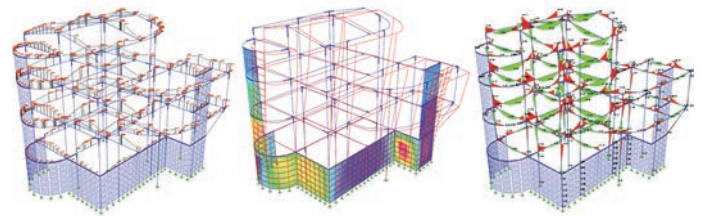
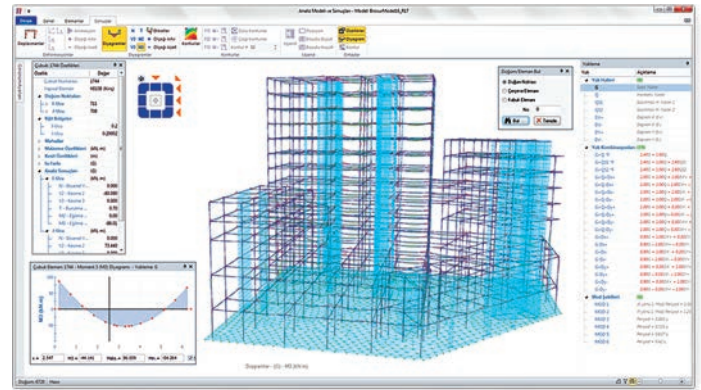

- › **Soil-Structure Interaction Analysis** for all types of foundations.
- › Define all types of **Seismic Base Isolators** at any level on columns and shearwalls.
- › Real-time visualization of stress contours, deformations, force and moment **diagrams** using the full-featured **Analysis Post-Processor**.
- › Automatic calculation of code-based seismic loads using **Equivalent Static** and **Response Spectrum Analysis** methods.
- › Performance assessment and retrofitting of existing buildings with **Elastic** and **Non-Linear Pushover** methods and preparation of detailed reports.
- › Share every detail of 3D analytical and physical model with general-purpose analysis programs (ETABS, SAP2000, SFrame, LUSAS, **Autodesk Revit**).

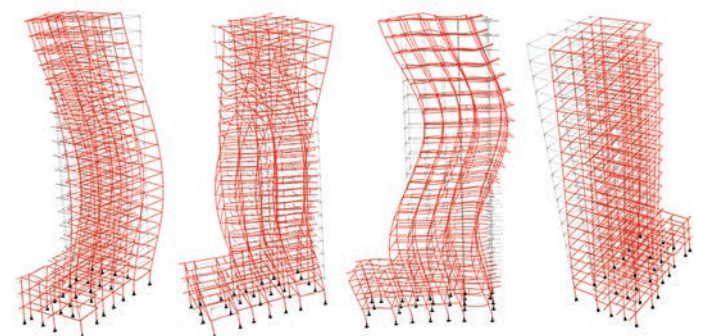
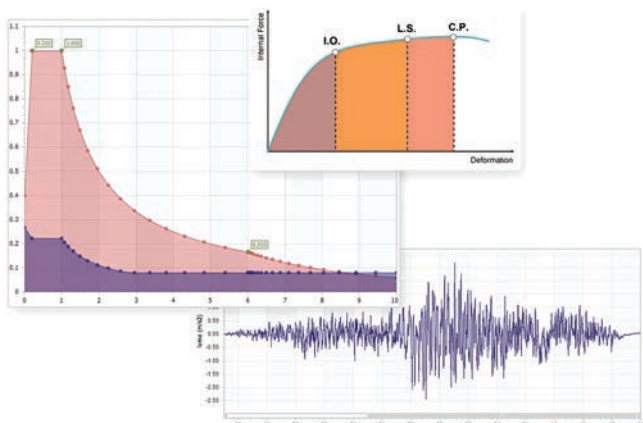

Mode Shapes

# Design and Foundations

- Code-based design of steel components to the **Eurocode 3, BS5950, AISC360-10** (ASD, LRFD) and New Turkish Steel Design Codes.
- Full-featured seismic analysis and design based on **Eurocode 8** and **UBC, IBC** and **TEC**.
- Automatic RC design based on ACI318, Eurocode 2, BS8110-1997, CP65, HK2004, BS6399 TS498 and TS500.
- Automatic design of **steel connections** and ability to reuse at all similar joints.
- **Automatic** and **interactive** selection of the most efficient steel profile based on active codes.
- Design of bottom and top chords, vertical and diagonal members of **steel trusses** using dedicated user interface.
- Design of shearwalls and slabs using mesh reinforcement.

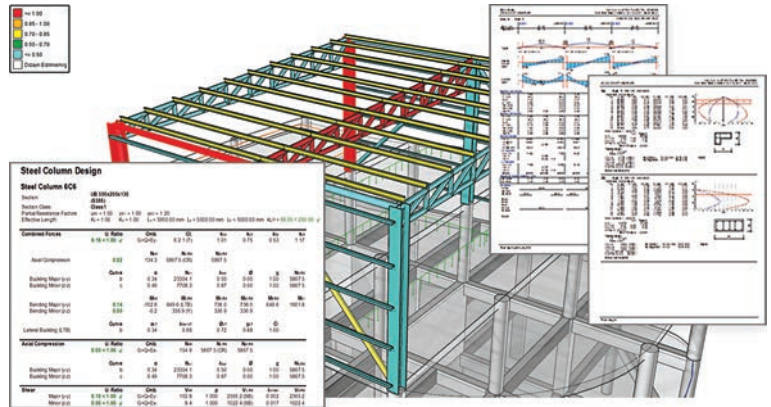

- **Biaxial design** and reinforcement optimization of columns and shearwalls with any section. Generation of interaction diagrams and capacity reports for easy design tracking.
- Code-based **automatic containment tools** to specify link and tie-bar layouts compatible with column sections of any shape and size.
- Automatically create reinforcement layouts for columns and **corewalls** with "I, H, L, T, U, E, +" sections.
- **Interactive** and **batch design, reinforcement optimizations** and **grouping** of beams, beam-lines and columns.
- Design of flat, ribbed, waffle slab systems using analytical and finite elements methods and automatic punching checks.
- **Integrated meshing** and analysis of slab and foundation systems with the building model.
- Design economically and accurately by including **column sections** in FE mesh and considering openings, drops and loads on slabs in FE analysis.

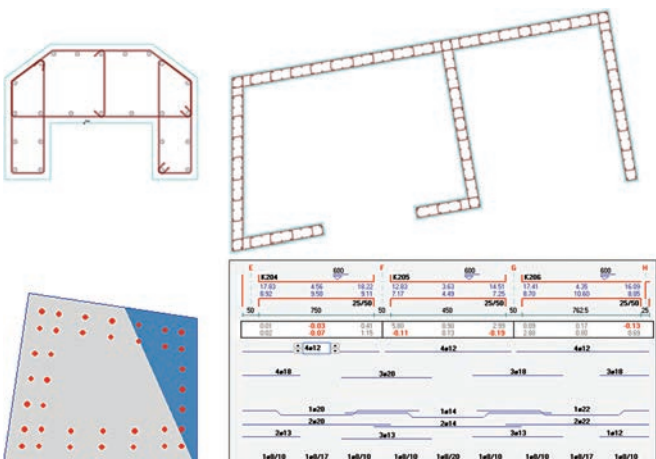

- **Advanced documentation tools** including ordered report sets, integration of external reports, table of contents, smart notification system (summary of warning, error and information messages)
- Design **pad bases, pile caps, strip foundations, rafts** and **piled rafts** using analytical and finite element methods.

- **Merge different models** to cater for common foundation systems.
- Use different **subgrade coefficients** and **different thicknesses** for each slab panel on raft foundations.

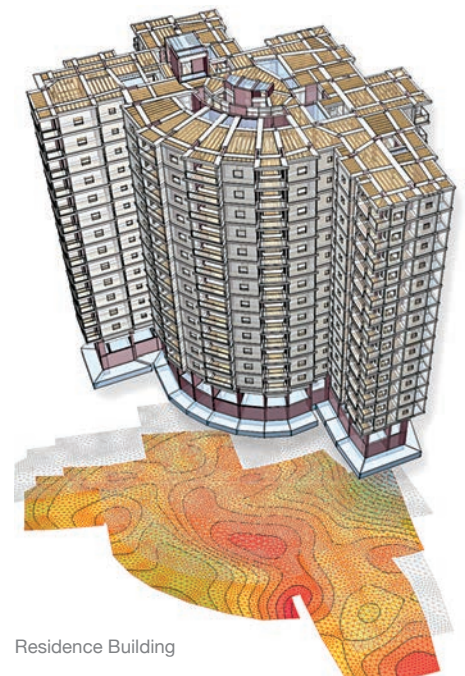
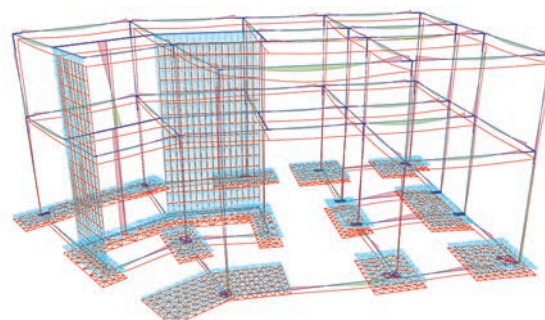
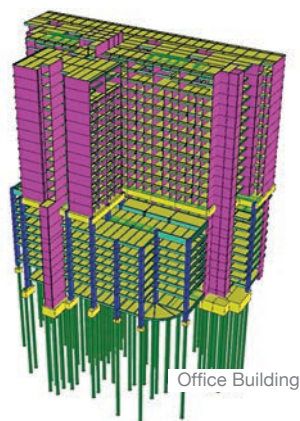

All RC details are automatically and seamlessly generated and design changes are managed easily using a **central 3D structural model**.

All quantity tables and detail items are updated dynamically thanks to **fully parametric smart rebars**.

- Automatically **produce details** from your **ProtaStructure** design models into your drawing sheets, only with one click.
- Generate **dynamic quantity tables** with full bar schedules, which are updated instantly when changes occur.
- Use **custom sheets** with your own title blocks with auto referencing of sheets to include all project and sheet information.
- Carry out your basic CAD tasks using standard drawing commands without the need for another tool. Features include extensive **command-line** support and customization, **DWG/DXF support**, dimensions, layers, style and much more...
- Make use of **smart rebar library**, **intelligent detailing items** and **tools** to perform **semi-automatic drafting** for the cases where a full automation is not possible.
- **Automatically or manually** truncate beam elevations to fit any sheet layout.
- Insert rebars **along the formwork lines** of complicated sections.
- Convert primitive line and polyline objects to smart rebars to instantly quantify existing detail drawing.
- Insert details with different drawing scales side-by-side on the same sheet. **Smart scaling system** automatically manages all relevant texts, object sizes and dimensions.
- **Automatically update design detail changes** from **ProtaStructure** as they occur.

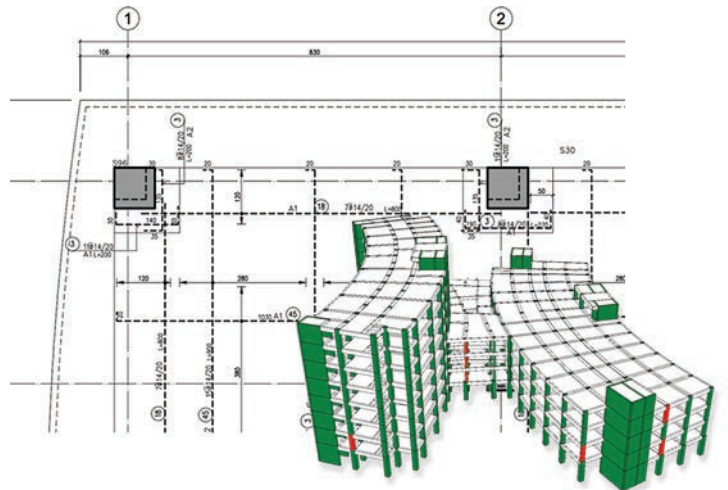

Hospital (with Seismic isolators)

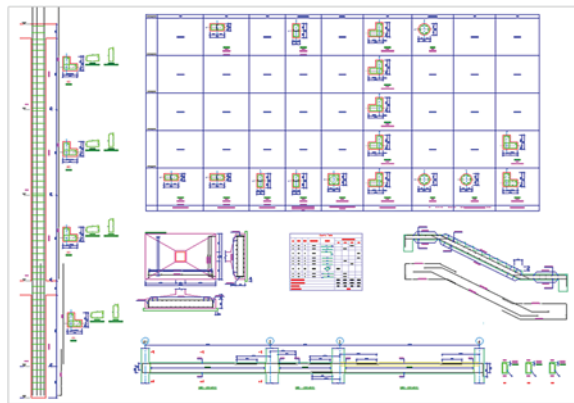

Use **ProtaDetails** growing library of design and detailing macros to design other components in your projects including;

- Automated analysis, design and detailing of **cantilever retaining walls**.
- Design of **Steel Scaffold Systems, RC Stairs, Pile Caps, Corbels** and more including all details, quantities and calculation reports.
- Design your piles using detailed soil profiles for **pile working load assessment**, iterative **lateral pile analysis** and **pile section design**.
- Produce engineering details for other components including Culverts, Retrofit Walls, Foundation Pits, Pad Bases, Walls and more.

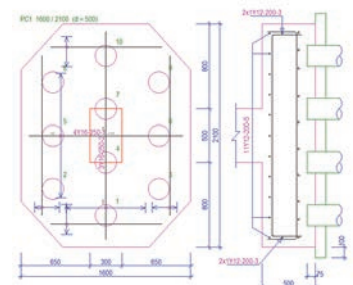
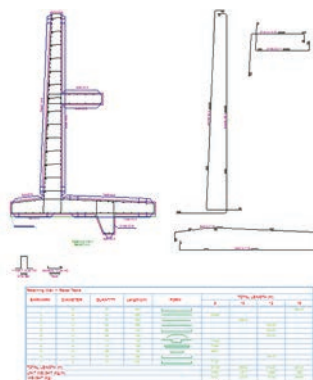



The challenging task of steel design and detailing dictates unique and project-specific engineering solutions for each project.

Automated connections and modelling macros in **ProtaSteel** boosts the productivity and significantly reduces the project delivery time. In addition to these, **ProtaSteel's** carefully tailored general purpose modelling and detailing tools enable industry professionals to create all types of **non-standard connections** and details easily using a **3D central model**.

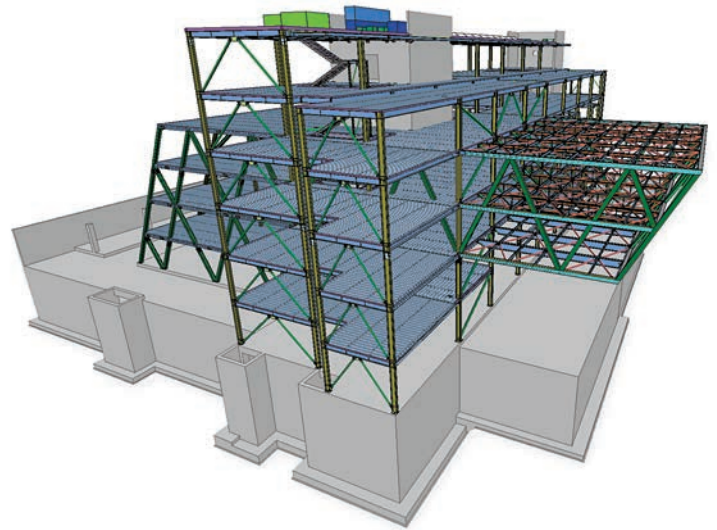

Office Building

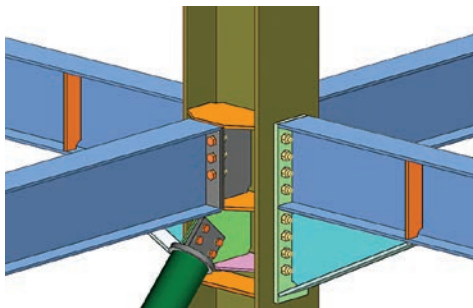

- Communicate **ProtaStructure** models directly to **ProtaSteel** and save precious time with **automatic connection design** and automatic preparation of **detail drawings** using a central 3D model.
- Easily model and design steel connections using **Fully-featured Parametric Connection Library**.
- Reduce the repetitive engineering effort spent on creating constructable connections. Powerful **IntelliConnect** engine automatically and accurately makes the decision for you and connects all joints considering joint geometry and other existing connections while conforming to user-defined rules and constructability criteria.
- Insert **ancillary steel** including sag rods, purlins, girts, braces, stairs, secondary beams and eaves beam to complete your model.
- Incorporate the design changes in **ProtaStructure** model to **ProtaSteel** without breaking the model optimized for fabrication.
- Automatically **detect all clashes** between parts.

- Fully-flexible **Automatic Part and Assembly Numbering** that intelligently manages part-marks on subsequent revisions of the model.
- Automatically prepare **General Arrangement Drawings, Truss Details, Connection Details, Shop Drawings and Material Lists**.
- Bi-directional data communication with Tekla Structures for fabricators and manufacturers.
- Easily create your own user-defined connections using general purpose tools like **plate, bolt, weld, section, cut, chamfer and fillet** and use these connections at similar joints.
- Enjoy productivity tools including **sectional plates, automatic stiffeners, profile notch and fitting and general 3D CSG cut macros**.

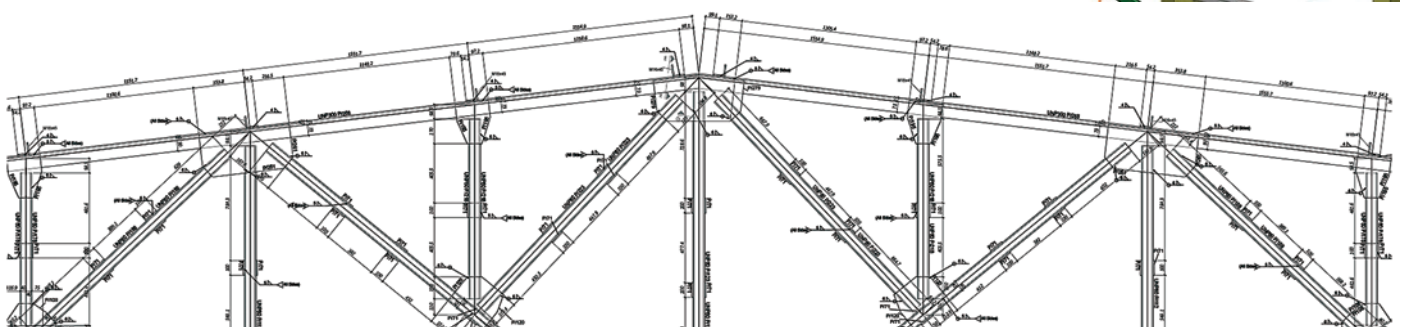
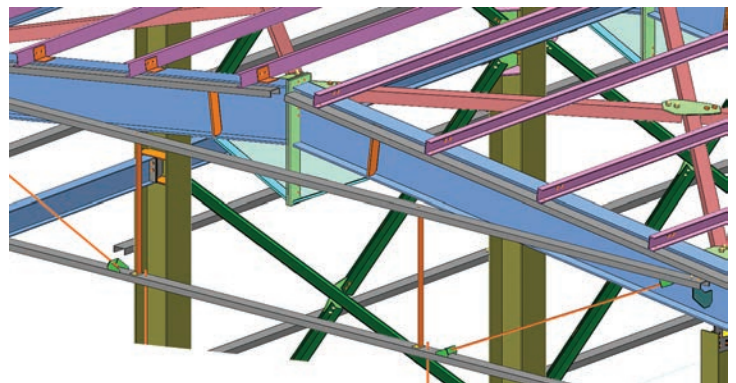

# Prota delivers leading technology for economical and efficient building design for engineering professionals around the world.

## Global Usage and Reliability

**Prota** has over thirty years of experience in delivering both professional consultancy services and structural software development globally. We are very familiar with requirements and work-flows of structural design.

**ProtaStructure** is developed by a highly experienced team of professional engineers, leading technical experts and software developers across the world.

To remain at the forefront of engineering excellence, **Prota** actively engages in research and development and has published more than 100 technical papers in various leading engineering publications and conferences globally over the past 10 years; especially in the fields of seismic design, retrofitting technologies and base isolation.

Thousands of engineers, CAD technicians and design professionals around the world use our software solutions to deliver their projects.

## Training and Technical Support

**ProtaStructure** comes with all the documentation you need to get started including quick start guides, training documents and videos. Additionally, our responsive technical support team are available to help you get the most out of **Prota's** solutions. Furthermore, hands-on training courses to get you moving are also offered in our fully-equipped classrooms by our friendly professional engineers.

## BIM and Interoperability

Open collaboration and sharing knowledge is a core principal at **Prota** which is why we have cultivated close relationships with leading technical research associates and the world's major BIM players including Autodesk®. This keeps us at the forefront of technical innovation, integrated design, BIM integration and project collaboration.



Hotel Building



Residence Tower



Offices and Shopping Mall



Hospital (Retrofitted with seismic isolators)

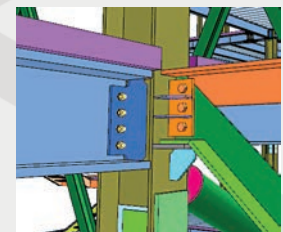
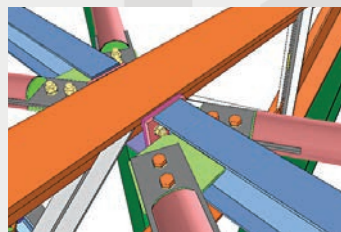

[www.protasoftware.com](http://www.protasoftware.com)

**Prota Asia Sdn Bhd**  
Unit 20-13A, Q Sentral, Jalen Stesen  
Sentral 2, KL Sentral, 50470  
Kuala Lumpur, Malaysia  
Tel: +603 2276 3355

**Prota Asia Pte Ltd**  
Level 39, 10 Marina Boulevard,  
Marina Bay Financial Centre,  
Tower 2, 018983 Singapore  
Tel: +65 6818 5766 Fax: +65 6818 5755