

# Intelligent/Conventional Life Safety Control Panel

## QS4



### Overview

EST's QS4 QuickStart life safety control panel provides conventional and intelligent addressable circuits in a single intelligent control panel. Designed for easy setup and simple installation, QuickStart lives up to its name in every respect. QS4's exclusive *QuickStart* auto-learn function, and the option of configuring the panel using convenient front panel programming or from a PC, makes short work of system setup. Devices come on-line in no time as well, thanks to QS4's built-in barcode scanner port. A simple pass of the optional scanner is all it takes to store device information in the QuickStart database. The scanner can also be used for quick and easy text entry when assembling custom messages.

QS4's setup routine is deceptively simple, considering this system's robust features and broad capacity. Supporting up to 1,000 intelligent detectors and modules, QS4 takes full advantage of EST's exclusive Signature Series technology, which provides electronic addressing, automatic device mapping, environmental compensation, and true multisensor detection.

As a hybrid system, QS4 combines Signature Series support along with up to 48 conventional Class B or a combination of 40 Class A and Class B initiating circuits. Compatible with either two- or four-wire detectors, these circuits also provide built-in support for EST's EC family of conventional detectors.

QuickStart's design leaves plenty of room for system expansion. Option cards snap onto QS4's easily-accessible DIN mounting rails. These cards include a dialer, auxiliary relays, and additional system capacity. The QS4 also supports as many as eight remote annunciators and up to 60 programmable front panel switches with dual LEDs for system control and display.

### Standard Features

- One to four Signature loops – each with a capacity of 250 Intelligent devices – PLUS up to 48 conventional circuits
- Compatible with two- and four-wire smoke detectors
- Combines the Signature intelligent releasing module with Signature multisensor detectors for reliable suppression
- Failsafe mode ensures uncompromised reliability
- Class A (Style 7) or Class B (Style 4) wiring options
- Capacity for eight remote annunciators
- Four built-in system relays
- Optional dual line dialer supports Contact ID and 4/2 formats
- Three methods of programming: QuickStart "auto-learn," front panel and personal computer (PC)
- Supports optional barcode scanner for direct device data entry
- Two optional banks of 30 front panel switches with dual LEDs
- Up to 20 adjustable pre-alarm settings for Signature smoke detectors
- Red or grey cabinets in two sizes for surface or semi-flush mounting
- Large 14-line (224 character) backlit LCD display
- Four password levels, plus priority access keyswitch
- Message routing by event type or by individual message
- Alarm sensitivity by time of day or manual selection
- 1,000 event history buffer, plus alarm history counter
- 6 amp Power Supply, 4.75 amps available for external use
- Envoy graphics compatible
- Compare utility identifies system changes and simplifies testing

## Application

QuickStart is a total life safety solution that brings the power of big-system analog technology to small and mid-size applications. Thanks to its flexibility and simple setup and operation, QS4 is ideal for new installations in schools, apartment buildings, hospitals, office buildings, and retail facilities.

The benefits brought by QS4 to retrofit applications underscores the true potential of this powerful system. As an intelligent panel, QS4 supports Signature Series devices, which can use existing wiring in most retrofit applications. As a conventional panel, QS4 supports compatible devices already installed at the site. And as a hybrid system, the QS4 supports new Signature Series devices, and existing conventional detectors – while leaving plenty of room for expansion. No need to tear a building apart to upgrade the life safety system: with QS4 you have the best of both worlds.

Which Quickstart Panel is right for you?	QSC	QS1	QS4
Signature Series devices supported	0	1 x 250	4 x 250
Conventional Class B circuits supported	3 x 16	0	3 x 16
Conventional Class A circuits supported	5 x 8	0	5 x 8
LCD display (lines x characters)	4 x 20	14 x 16	14 x 16
Optional Zone Switch/LEDs on front panel	2 x 30	1 x 30	2 x 30
Option card spaces	5 or 12	1	5 or 12
For more information, see Data Sheet ...	85005-0112	85005-0113	85005-0114

## CPU / LCD Display

The QS4 front panel display provides 14 lines by 16 characters of text detailing event, device, diagnostic, and programming information. Its large backlit LCD screen is easy to read and always provides at-a-glance indication of the system's state of operation. The CPU/Display Unit houses the CPU card and mounting space for two optional LED/Switch cards.

QS4 is as simple to operate as it is to set up. Its large 14-line backlit LCD display provides easy-to-understand details concerning up to 1,000 system events, while bright system status LEDs and large, tactile control buttons present the user with a clean, crystal clear interface. Four password levels limit control and information retrieval to authorized personnel. A priority access keyswitch gives Level 2 access, without a password, to management and emergency personnel.

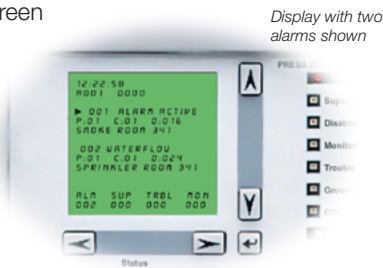

## Specifications

Control Panel	Standby Current: 199 mA Alarm Current: 235 mA
Remote annunciator (Full control versions)	Standby Current: 154 mA Alarm Current: 166 mA
SRA Series	Standby Current: 70 mA Alarm Current: 90 mA
Operating environment	Temperature: 32–120 °F (0–49 °C) Humidity: 93 %RH, non-condensing

## Failsafe Mode

If the CPU loses communication with other circuit cards, the power supply card continues to monitor the system for any alarm events. If an alarm occurs on any device or circuit during a communications failure, the power supply activates all alarm outputs and instructs the dialer to transmit a default alarm message to the monitoring station.

## Remote Annunciators

QS4 supports up to eight remote annunciators, which provide mirrored annunciation of front panel messages and status indicators. Three annunciator series are available: QSA, SRA, and R.

## R-Series Annunciators

R-Series Annunciators are high-performance remote annunciators that provide status indication and common controls for QuickStart and other compatible fire alarm control panels. This family of annunciators offers LCD or LED annunciation. Models are available with and without common controls.



There are three R-Series annunciator models, plus an LED-based expander. Up to two expanders can be connected to any annunciator. The expander includes 24 pairs of LEDs that extend the capabilities of any of the annunciators.

All annunciator models include status LEDs and an internal buzzer. Two models have an LCD text display, and one has 16 pairs of LEDs for zone annunciation. LCD models feature a large back-lit, four by twenty character per line, super-twist liquid crystal display.

R-Series annunciators and expanders are mounted on a standard 4-inch square electrical box, using the included mounting ring. They can also be surface mounted in locking steel enclosures. Three different enclosures are available.

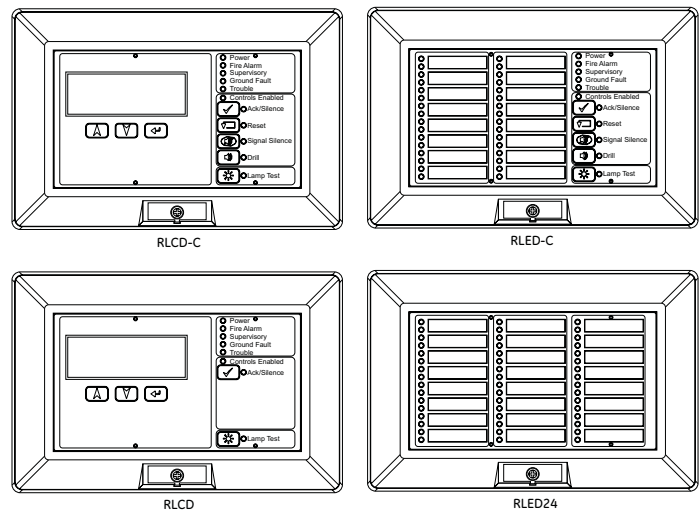

## QSA Series



QuickStart's Class A serial remote annunciator bus requires an X485 (RS485) card and UART port at the control panel. Each remote annunciator requires only a

UART port. Class B wiring does not require an X485 card at the control panel. Remote annunciators are available in both analog and conventional versions and with wallboxes for flush or surface mounting. Models are available with one or two annunciator option spaces, each with 30 dedicated switches and LEDs. See the Ordering Table for more information.

### Class B Wiring

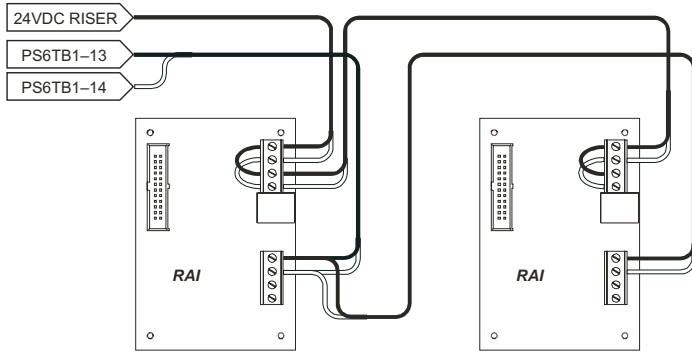

### Class A Wiring

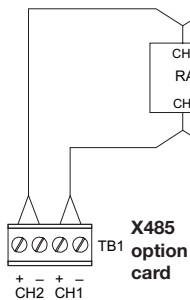

### Dimensions

Model	Height	Width	Depth
QSA-1-S	7.6" (19.46 cm)	14.25" (36.20 cm)	2.9" (7.3 cm)
QSA-1-F (rough in)	6.56" (16.66 cm)	13.25" (33.66 cm)	2.1" (5.33 cm)
QSA-1-F (finished)	7.8" (19.81 cm)	14.42" (36.63 cm)	1.38" (3.49 cm)
QSA-2-S	7.6" (19.46 cm)	18.56" (47.14 cm)	2.9" (7.3 cm)
QSA-2-F (rough in)	6.56" (16.66 cm)	17.56" (44.60 cm)	2.1" (5.33 cm)
QSA-2-F (finished)	7.8" (19.81 cm)	18.75" (47.63 cm)	1.38" (3.49 cm)

*Rough-in dimensions reflect the size of the cabinet where it enters the wall.  
Finished dimensions reflect the size of the cabinet that protrudes from the wall.*

## SRA Series

QuickStart SRA Remote Annunciators are standalone units that can be powered by the control panel or by an approved power supply. Annunciators support Class A or Class B connection to the system RS-485 data line, but do not provide ground fault isolation. SRA Annunciators are available in single or multiple loop models.



### Mounting

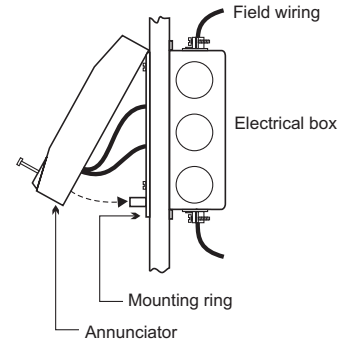

SRA Series Annunciators include an RJ-12 modular jack to allow system database downloads from a laptop computer. Connection requires a programming cable (model number PROG-CABLE-1, ordered separately). Annunciators are mounted to 4-inch square electrical boxes.

### Class B Wiring

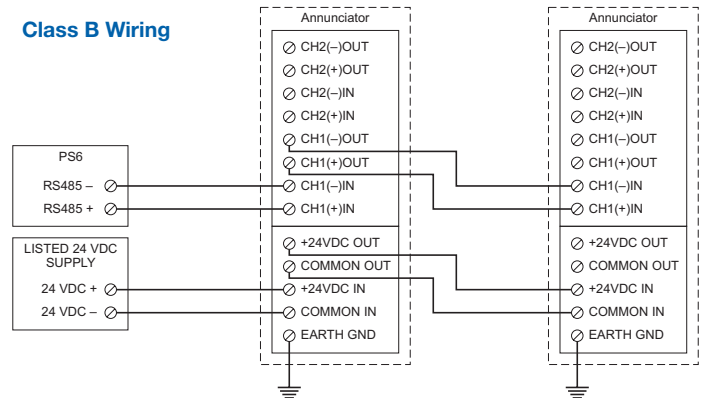

### Class A Wiring

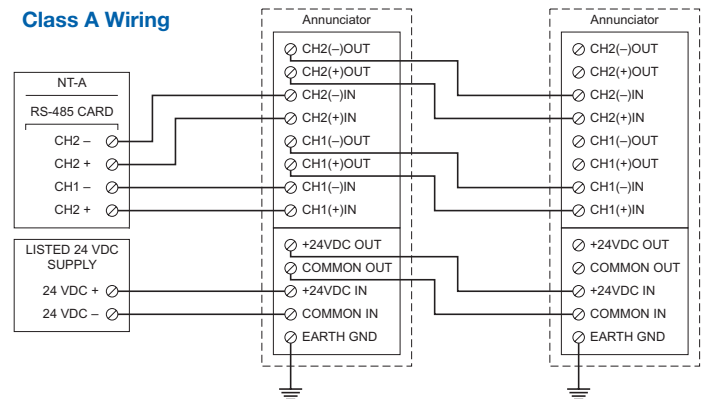

### XGD Graphics Driver Card

The XGD Graphics Driver Card is an interface device that connects a QuickStart annunciator to an Envoy Graphic Annunciator. The XGD provides the electronics required to support 24 LEDs and 12 switches on the Envoy display panel. Multiple XGD cards can be chained together in one graphic annunciator cabinet to control larger displays. The QuickStart SRA Series annunciators can support a maximum of six XGD cards.

# Operation

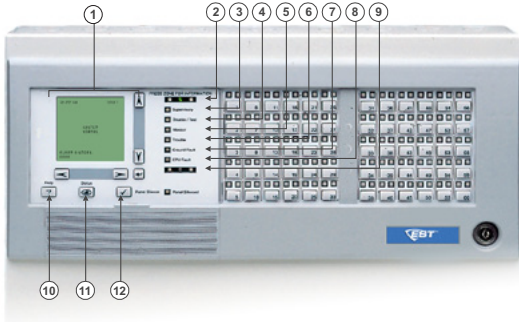

## Indicators

1. **Text display and controls:** Displays system messages, status information, and programming menus. Arrow buttons move the display cursor.
2. **Alarm LED:** Indicates a fire or life threatening emergency.
3. **Supervisory LED:** Indicates an off-normal condition with the fire suppression system or related equipment.
4. **Disable/Test LED:** Indicates part of the system is disabled or being tested. Disabled components also signal a system trouble.
5. **Monitor LED:** Indicates the operation of an ancillary system function (door closures, fan pressure switches).
6. **Trouble LED:** Indicates an off-normal condition or wiring fault that compromises the integrity of the system.
7. **Ground Fault LED:** Indicates a ground fault in the system wiring. Ground faults also signal a system trouble.
8. **CPU Fail LED:** Indicates an unexpected reboot or failure with the microprocessor. CPU failures also signal a system trouble.
9. **Power LED:** Indicates the panel has power.
10. **Help button:** Provides additional information about the device selected on the display.
11. **Status button:** Displays the Status Menu from which you can identify active or disabled points in the system.
12. **Panel Silence/Acknowledge button and LED:** Acknowledges all events posted in the display queues and turns off the panel buzzer. The panel silenced LED indicates that off normal events have been acknowledged.

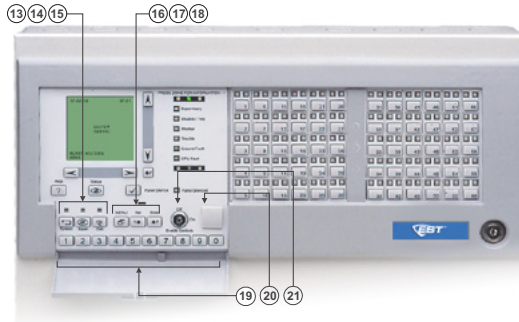

## Controls

13. **Reset button:** Allows devices or zones in alarm or trouble to restore to their standby condition. The LED indicates that the panel is resetting.
14. **Alarm Silence button:** Turns active notification appliances off depending on panel programming. Pressing Alarm Silence a second time turns them back on. The LED indicates that the panel is in alarm and operating with notification appliances turned off.
15. **Drill button:** Activates notification appliances depending on panel programming but does not place the panel in alarm. The LED indicates that the panel is in Drill Mode.
16. **Menu button:** Displays the operator menus.
17. **Delete button:** Returns to the previous menu or backspaces the cursor.
18. **Enter button:** Press the Enter button to accept information or continue to the next item.
19. **Numeric keypad:** Numbered buttons for entering values and making menu selections.
20. **Barcode scanner jack:** Input for optional barcode scanner.
21. **Priority Access keyswitch:** Enables control functions reserved for access level 2 and above without requiring a password.

## Cabinet Dimensions

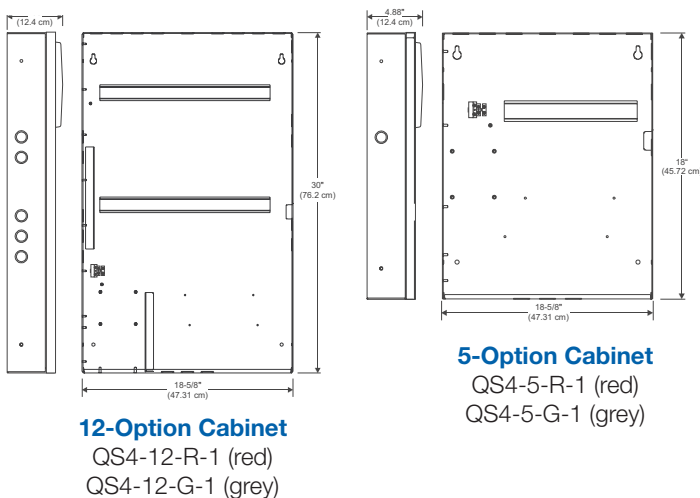

## Cabinet Mounting

12 and 5-Option Cabinets

*Semi-flush mounting requires an optional trim ring, which adds 3/4" to all sides of the panel.*

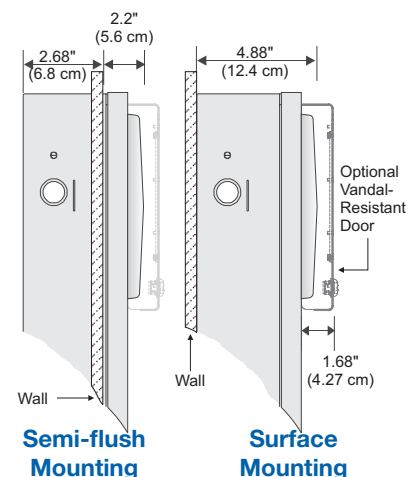

# Typical Wiring

## QS4 Addressable and Conventional Circuit Options

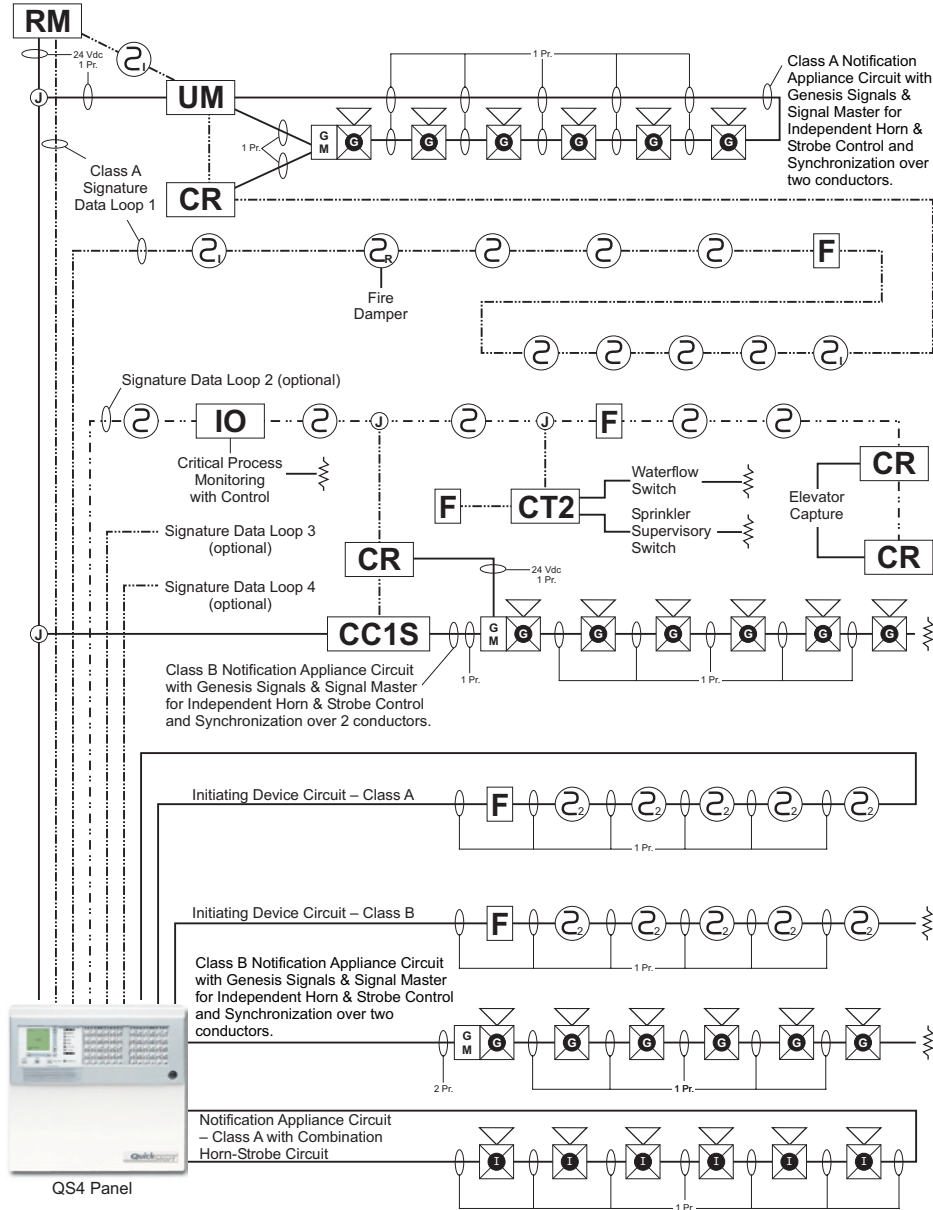

### LEGEND

- Enhanced Integrity Horn-Strobe
- Genesis Horn-Strobe
- Genesis Signal Master
- Smoke Detector
- 2-Wire Smoke Detector
- Smoke Detector with Relay Base
- Smoke Detector with Isolator Base
- Manual Pull Station
- Junction Box
- End-of-Line Resistor
- Programmable I/O Module
- Universal I/O Module
- Dual Circuit Input Module
- Control Relay Module
- Signal Module
- Signal Module (synchronization)
- Riser Monitor Module

More wiring suggestions can be found in the QS4 Fire Alarm Control Panel Installation, Operation, and Maintenance Manual, P/N 3100186.

## Coded Signaling

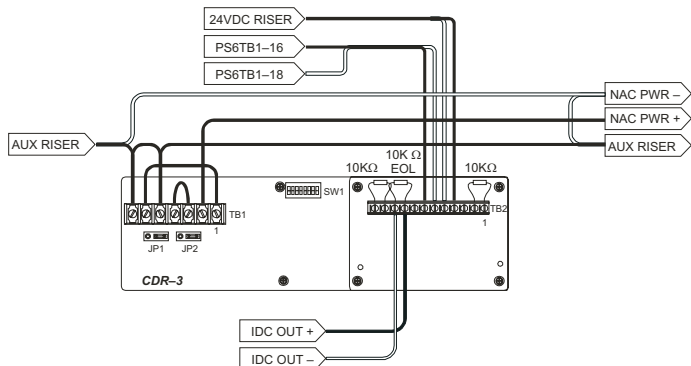

## Fire Suppression

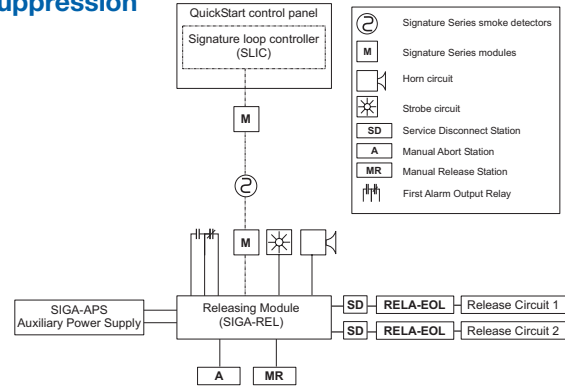

# Standard Components and Option Cards

All QS4 panels come standard with a CPU/Display Unit, and a PS6 Power Supply (see ordering information for details).

QuickStart option cards provide a wide range of features and extra system capacity. Thanks to the convenient Quick-Lok mounting system, option cards snap onto the DIN mounting rails easily and securely. Wallboxes are available in two sizes with room for either five or 12 single-space option cards. Both sizes of wallbox feature easily-accessible mounting rails and plenty of room for cabling.



12-option card cabinet with option cards and batteries installed.

## PS6 Power Supply Card

## Standard Component

### Description

The PS6 provides primary dc power to all the circuit cards installed in the cabinet. There are four 24 Vdc power output circuits – three for powering auxiliary applications, and one for powering four-wire smoke detectors – and a charging circuit for standby batteries. The PS6 also provides common alarm, supervisory, and trouble relays, as well as a fourth relay that is user programmable.

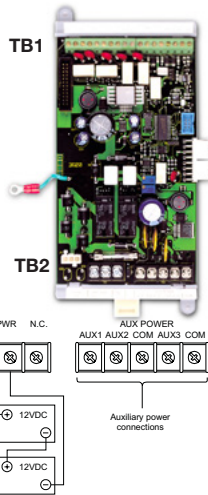

### Wiring

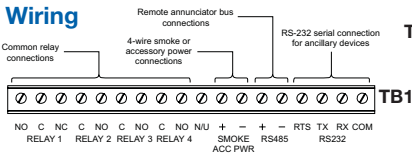

- Relay 1:** Form C. Contacts change position when the control panel processes an alarm signal and remain changed until all active alarm inputs restore and the control panel resets.
- Relay 2:** Form A. Contacts change position when the panel processes a supervisory signal and remains changed until all active supervisory inputs restore.
- Relay 3:** Form A. Contacts change position when the panel loses power or processes a trouble signal and remains changed until power returns or the trouble clears.
- Relay 4:** Form A. Relay closes and opens according to panel programming.
- Smoke/Accessory Power:** Jumper setting determines if the 24 Vdc is constant or resettable.

### Specifications

Main supply circuit	AC input: 115 or 230 Vac, 50/60 Hertz DC input: 24 Vdc batteries
Battery charging circuit	Charge current: 2 amps Charge capacity: 40 amp hours (UL) 30 amp hours (ULC)
Smoke/Accessory power output circuit	Voltage: 24 Vdc, regulated Current: 250 mA Wire size: 12 to 18 (0.75 to 2.5 mm <sup>2</sup> )
Auxiliary power output circuits	Quantity: 3 Voltage: 24 vdc full wave rectified Current: 1.5 amps each
Common alarm relay	Style: Form C Contact rating: 1 amp Wire size: 12 to 18 AWG (0.75 to 2.5 mm <sup>2</sup> )
Trouble, Supervisory and programmable relays	Style: Form A (N/O) Contact rating: 1 amp Wire size: 12 to 18 AWG (0.75 to 2.5 mm <sup>2</sup> )
Operating environment	Temperature: 32 - 120° F (0 - 49° C) Humidity: 93 %RH, non-condensing
Current requirements	Standby current: 72 mA Alarm current: 96 mA

## SLIC Signature Loop Intelligent Controller

## Option Card

### Description

The SLIC provides one Class A or Class B data circuit (loop) for connecting Signature Series detectors and modules. The SLIC also provides two programmable Class A or Class B notification appliance circuits (NACs) for connecting polarized 24 Vdc notification appliances such as horns and strobes. QS4 supports up to four SLICs.

### Wiring

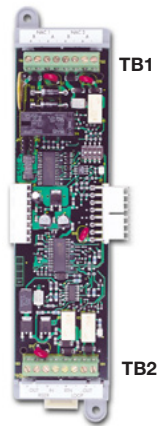
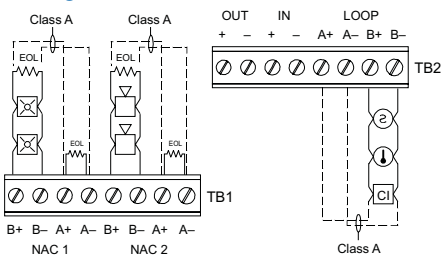

Signaling Line Circuit and NACs are supervised and power-limited.

### Specifications

Signaling line circuit	Configuration: Class B (Style 4) or Class A (Style 7) Capacity: 125 Signature detectors 125 Signature modules Wire size: 18 to 12 AWG (0.75 to 2.5 mm <sup>2</sup> ) Circuit resistance: 65 ohms Circuit capacitance: 0.3 μf
Notification appliance circuits #1 and #2	Configuration: Class B or Class A Output voltage: 24 Vdc, nominal Output current: 2.0 A at 24 Vdc for #1 and 0.8 A at 24vdc for #2 Wire size: 18 to 12 AWG (0.75 to 2.5 mm <sup>2</sup> ) End of line resistor: 10k ohms, ½ W
NAC power input circuit	Voltage: 24 Vdc, nominal Wire size: 18 to 12 AWG (0.75 to 2.5 mm <sup>2</sup> )
Operating environment	Temperature: 32 - 120° F (0 - 49° C) Humidity: 93 %RH, non-condensing
Current requirements	Standby current: 33 mA Alarm current: 57 mA (Both NACs on)
Card spaces	Requires one card space.

**Description**

The **ZB16-4 Zone Card** provides sixteen circuits for connecting Class B conventional input and output zones. Twelve circuits are dedicated initiating device circuits (IDCs) for connecting 2-wire smoke detectors and dry-contact initiating devices. Four circuits can be configured as either IDCs or as notification appliance circuits (NACs) for connecting polarized 24 Vdc notification appliances such as horns or strobes.

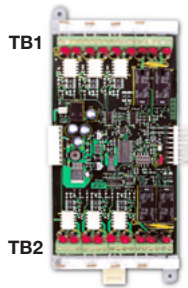

**Wiring (ZB16-4)**

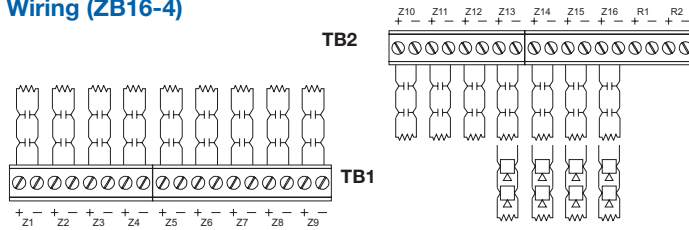

The **ZA8-2 Zone Card** provides eight circuits for connecting Class A conventional input and output zones. Six circuits are dedicated initiating device circuits (IDCs) for connecting 2-wire smoke detectors and dry-contact initiating devices. The remaining two circuits can be configured as either IDCs or as notification appliance circuits (NACs) for connecting polarized 24 Vdc notification appliances such as horns or strobes.

**Wiring (ZA8-2)**

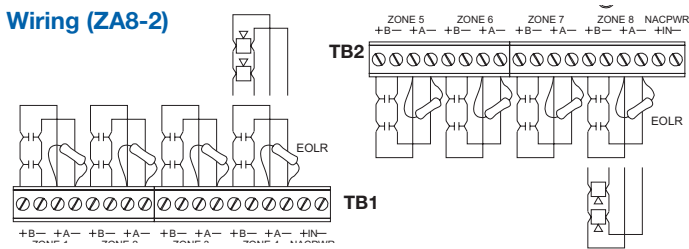

Specifications	ZB16-4	ZA8-2
<b>Initiating device circuits</b>		
Quantity	12 to 16	6 to 8
Wiring configuration	Class B	Class A
Detector voltage	19.9 – 24.0 Vdc, max ripple 400 mV	
End of line resistor	4.7k ohms, 1/2W	
Short circuit current	31 mA, max.	
Resistance	50 Ohms, max.	
Capacitance	100 µF, max.	

**NAC power input circuit**

Voltage	24 Vdc
Wire size	18 to 12 AWG (0.75 to 2.5 mm <sup>2</sup> )

**Notification appliance circuits**

Quantity	1 to 4	1 or 2
Wiring configuration	Class B	Class A
End of line resistor	10k ohms, 1/2W	
Output voltage	24 Vdc, nominal	
Output current	2.0 A, 24 Vdc	
Wire size	18 to 12 AWG (0.75 to 2.5 mm <sup>2</sup> )	

**Operating environment**

Temperature	32–120° F (0–49° C)
Humidity	93 %RH, non-condensing

**Current requirements**

Standby	117 mA	73 mA
Alarm	152 mA	116 mA
Maximum cards in panel	Three (48 zones)	Five (40 zones)
	40 zones maximum when both ZB16-4 and ZA8-2 cards installed.	
Card Spaces	Requires two card spaces.	

**DLD Dialer**

Option Card

**Description**

The DLD is a ULI/ULC listed dual line Digital Alarm Communicating Transmitter (DACT). It provides two phone line connections for sending system messages to a compatible Digital Alarm Communicator Receiver. The DLD supports 4/2 and Contact ID formats. It occupies one card space on the chassis rail.

**Wiring**

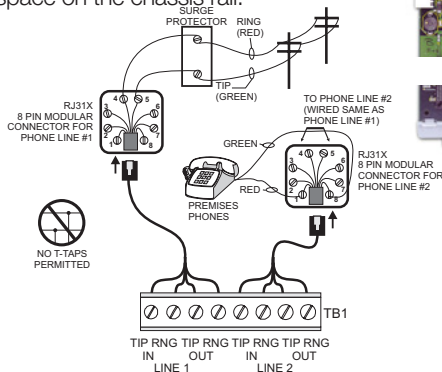

**Specifications**

Operating environment	Temperature: 32 - 120 ° F (0 - 49 ° C)
	Humidity: 93% RH, non-condensing
Current requirements	Standby: 13 mA
	Alarm: 20 mA
	Dialing: 26 mA
Phone Lines	Two loop start lines on switched telephone network. Pulse or DTMF dialing.
Wall Connector	RJ31X/CA31A equiv. or RJ38X/CA38A equiv.
Communications Protocol	Contact ID (SIA DC-05), 4/2 (SIA DC-02 P3).
Programming	Via QuickStart, Front Panel or PC.
Communications Compliance	Communications Canada CS-03FCC/CFR 47 Parts 15 and 68, NFPA 72, ULI 864, ULC S527-M87
Receivers	Signals can be transmitted to either or both of two receivers.
Telephone #s	Two 24-digit numbers per receiver.
Card spaces	Requires one card space.

**Description**

The SL30 and SL30-1 provide thirty circuits for zone annunciation. Each circuit comprises two LEDs and a push button switch. The **SL30** push button switches are numbered from 1 to 30 and the **SL30-1** push button switches are numbered from 31 to 60. The **SL20L5S** provides 20 circuits for point annunciation and five circuits for custom control functions. The **SL30L** provides 30 circuits for point annunciation. SL20L5S and SL30L circuits are labeled using inserts provided with the cards.



**Specifications**

Operating environment	Temperature: 32 - 120 ° F (0 - 49 ° C)
	Humidity: 93% RH, non-condensing
Current requirements	Standby: 1mA Alarm: 0.75 mA per active LED

**ZR8 Relay Card**

Option Card

**Description**

The ZR8 provides eight dry-contact relays that can be independently configured as Form A or Form B relays. It occupies one card space on the chassis rail.

**Wiring**

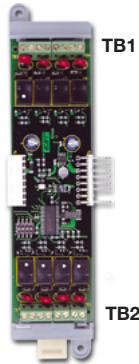
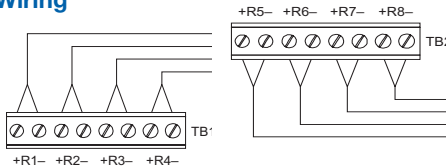

**Specifications**

Output relays	Style: Form A (N/O) or Form B (N/C) (jumper configurable)
	Contact rating: 1 amp @ 30 Vdc resistive.
	Wire size: 18 to 12 AWG (0.75 to 2.5 mm <sup>2</sup> )
Operating environment	Temperature: 32 - 120° F (0 - 49° C)
	Humidity: 93 %RH, non-condensing
Current requirements	Standby: 11 mA
	Alarm: add 18 mA per active relay
Card spaces	Requires one card space.

**X485 Class A RS-485 Card and QS-232 Port**

Option Cards

**Description**

The NT-A, which includes the X485/RS-485 card and QS-232/UART port, provides one Class A serial remote annunciator bus for connecting remote annunciator panels. Control panels require the X485 card and QS-232 port, which also serves as a laptop or printer port. The X485 occupies one card space on the chassis rail. The QS-232 port plugs into the panel CPU.

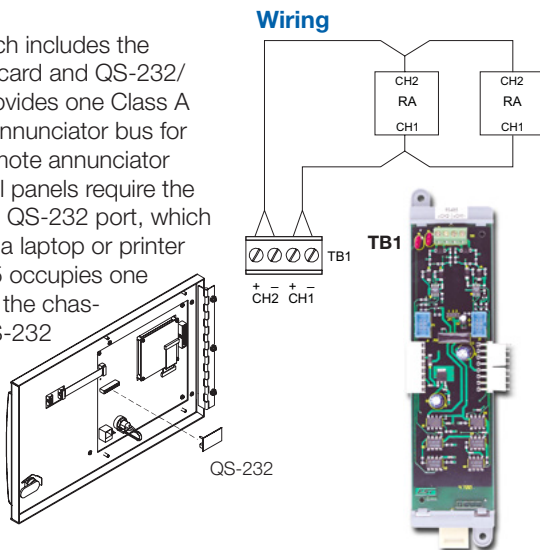

**Specifications**

Wire size	12 to 18 AWG (0.75 to 2.5 mm <sup>2</sup> ) twisted pair (6 twists per foot minimum)
Circuit resistance	100 Ohms
Circuit capacitance	0.4 µF
Operating environment	Temperature: 32 - 120° F (0 - 49° C)
	Humidity: 93 %RH, noncondensing
Current requirements	Standby: 60 mA
	Alarm: 60 mA
Card Spaces	Requires one space for the NT-A



## Ordering Information

Part Number	Description	Ship Wt. lb. (kg.)
<b>Basic Package - Enclosure, Power Supply, CPU and Display, 115v transformer...</b>		
QS4-5-G-1	Intelligent/Conventional System. Five option card spaces. Gray.	17.0 (7.71)
QS4-5-R-1	Intelligent/Conventional System. Five option card spaces. Red.	17.0 (7.71)
QS4-12-G-1	Intelligent/Conventional System. 12 option card spaces. Gray. QS-Cable12 required.	30.0 (13.61)
QS4-12-R-1	Intelligent/Conventional System. 12 option card spaces. Red. QS-Cable12 required.	30.0 (13.61)

### Enclosure Accessories

QS-2-VR	Vandal-resistant cabinet door, gray	3.0 (1.36)
QS-2-VR-R	Vandal-resistant cabinet door, red	3.0 (1.36)
QS-Cable12	Expansion Cable for 12-option card cabinets.	0.5 (0.23)
Trim-5	Gray Flush mount trim ring for QS-5-G-1.	5.0 (2.27)
Trim-5R	Red Flush mount trim ring for QS-5-R-1.	5.0 (2.27)
Trim-12	Gray Flush mount trim ring for QS-12-G-1.	8.0 (3.63)
Trim-12R	Red Flush mount trim ring for QS-12-R-1.	8.0 (3.63)

### Initiating/Notification Circuit Option Cards

SLIC	Signature Loop Intelligent Controller. Supports one SLC of up to 250 devices. Card includes one Class A or two Class B NACs.	1.0 (0.45)
ZB16-4	Conventional Zone Card. 16 Class B circuits, four convertible to Class B NAC's. Requires 2 card spaces.	2.0 (0.91)
ZA8-2	Conventional Zone Card. Eight Class A circuits, two convertible to Class A NAC's. Requires 2 card spaces.	2.0 (0.91)

### Other Option Cards

DLD	Dual Line Dialer. Supports 4/2 & Contact ID formats.	1.0 (0.45)
ZR8	Relay Card. 8 programmable Form A contacts.	1.0 (0.45)

### Display Options

SL30	Annunciator module. Numbered 1 to 30. Two LEDs and one switch per zone.	1.0 (0.45)
SL30-1	Annunciator module. Numbered 31 to 60. Two LEDs and one switch per zone.	1.0 (0.45)
SL20L5S	Annunciator module. 20 circuits for point or zone annunciation, 5 circuits for custom functions. Circuits labeled with insert card.	1.0 (0.45)
SL30L	Annunciator module. Circuits labeled with insert card.	1.0 (0.45)
NT-A	RS-485 option card. Required for Class A remote annunciation. Includes UART card.	1.0 (0.45)

Part Number	Description	Ship Wt. lb. (kg.)
QS-232	UART option card. Plugs into CPU. Required for PC Programming / printer port. Included in NT-A package	1.0 (0.45)

### Remote Annunciator CPUs

QS4-CPU-1	Intelligent/Conventional CPU/Display. One annunciator option space. Order backbox below.	4.0 (1.81)
QS4-CPU-2	Intelligent/Conventional CPU/Display. Two annunciator option spaces. Order backbox below.	4.0 (1.81)
EST-SRA4	Intelligent/Conventional CPU/Display with integrated LCD and control switches. 4" square box mount.	4.0 (1.81)

### Remote Annunciator Cabinets (c/w Interface Assembly; Require CPU/Display)...

QSA-1-S	Surface Annunciator Cabinet. Holds one SL30.	4.0 (1.81)
QSA-1-F	Flush Annunciator Cabinet. Holds one SL30.	4.0 (1.81)
QSA-2-S	Surface Annunciator Cabinet. Holds two SL30s.	5.0 (2.27)
QSA-2-F	Flush Annunciator Cabinet. Holds two SL30s.	5.0 (2.27)
QSA-1-S-VR	Surface Annunciator Cabinet. Vandal resistant. Holds one SL30.	4.0 (1.81)
QSA-1-F-VR	Flush Annunciator Cabinet. Vandal resistant. Holds one SL30.	4.0 (1.81)
QSA-2-S-VR	Surface Annunciator Cabinet. Vandal resistant. Holds two SL30s.	5.0 (2.27)
QSA-2-F-VR	Flush Annunciator Cabinet. Vandal resistant. Holds two SL30s.	5.0 (2.27)

### R-Series LCD Remote Annunciators

RLCD	Remote Annunciator, 4X20 LCD & Common Indicators for displaying system status, mounts 4" Square electrical box, gray housing.
RLCD-R	Remote Annunciator, 4X20 LCD & Common Indicators for displaying system status, mounts 4" Square electrical box, red housing.
RLCD-C	Remote Annunciator, 4X20 LCD, Common Indicators & Common Controls for displaying system status, mounts 4" Square electrical box, gray housing.
RLCD-CR	Remote Annunciator, 4X20 LCD, Common Indicators & Common Controls for displaying system status, mounts 4" Square electrical box, red housing.

*For French common control, add suffix F to model number.*

*more...*

## Ordering options

(Apply to basic packages and CPU/displays only)

### Languages

**No suffix** = American English  
**SP** = Spanish (230v or 115v)  
**PG** = Portuguese (230v only)  
**FR** = French Canadian (120v only)

### Power Supplies

**1** = 115v transformer  
**2** = 230v transformer

### Colors

**G** = Grey enclosure (230v or 115v)  
**R** = Red enclosure (115v only)

### Examples

**QS4-5-G-2-SP** = QS4 basic package with five option card spaces, grey enclosure, 230v transformer, Spanish language.

**QS4-CPU-2-FR** = QS4 CPU/display, two annunciator option spaces, French Canadian.



**Detection & alarm since 1872**

U.S.  
T 888-378-2329  
F 866-503-3996

Canada  
Chubb Edwards  
T 519 376 2430  
F 519 376 7258

Southeast Asia  
T : +65 6391 9300  
F : +65 6391 9306

India  
T : +91 80 4344 2000  
F : +91 80 4344 2050

Australia  
T +61 3 9239 1200  
F +61 3 9239 1299

Europe  
T +32 2 725 11 20  
F +32 2 721 86 13

Latin America  
T 305 593 4301  
F 305 593 4300

utcfireandsecurity.com

© 2010 UTC Fire & Security.  
All rights reserved.

## Ordering Information

Part Number	Description	Ship Wt. lb. (kg.)
<b>LED Remote Annunciators &amp; Expander</b>		
RLED-C	Remote Annunciator, Common Indicators for displaying system status, common controls & 16 groups w/2 LEDs each for zone display, mounts to standard 4" Square electrical box, gray housing.	
RLED-CF	Remote Annunciator, Common Indicators for displaying system status, common controls & 16 groups w/2 LEDs each for zone display, mounts to standard 4" Square electrical box, gray housing, French.	
RLED-CR	Remote Annunciator, Common Indicators for displaying system status, common controls & 16 groups w/2 LEDs each for zone display, mounts to standard 4" Square electrical box, red housing.	
RLED24	Remote Annunciator Zone expander, 24 groups of 2 LEDs each for display of alarm and trouble. Each with custom label area. Mounts to standard 4" electrical box, gray housing.	
RLED24R	Remote Annunciator Zone expander, 24 groups of 2 LEDs each for display of alarm and trouble. Each with custom label area. Mounts to standard 4" electrical box, red housing.	
<b>Graphic Annunciator Drivers</b>		
GCI	Graphic Annunciator Driver, provides outputs for common indicators and 32 alarm/supv zones as well as inputs for common switches. Provided with a snap track for mounting in custom graphic enclosures.	
<b>Remote Annunciator Cabinets &amp; Accessories</b>		
RA-ENC1	Remote Annunciator Enclosure, key locked with plexiglass window for one RLCD(C) or RLED(C).	
RA-ENC2	Remote Annunciator Enclosure, key locked with plexiglass window with space for 2 of either RLCDx, RLEDx or RLED24.	
RA-ENC3	Remote Annunciator Enclosure, key locked with plexiglass window with space for 3 of either RLCDx, RLEDx or RLED25.	
RKEY	Keyswitch, single gang, provides key operated enable or disable of common controls on RLCD or RLED units.	
LSRA-SB	Surface Mount Box - for R Series single units.	
<b>Programming Tools</b>		
QS-CU	QuickStart Panel Configuration Utility.	1.0 (0.45)
QS-Scan	QuickStart scanner and programming guide.	2.0 (0.91)
Progcable-1	Scanner port upload/download cable	1.0 (0.45)
260097	Programming cable (PC to QSC, QS1, QS4)	1.0 (0.45)
<b>Accessories</b>		
PT-1S	SystemPrinter - Desk top Style	14.0 (6.35)
BC-1(R)	Battery Cabinet. Holds 1 40 Ah or 2 24 Ah batteries.	22.0 (9.98)
MFC-A	MultiFunction Cabinet.	7.0 (3.1)
IOP3A	RS-232 Isolator Module.	3.0 (1.36)
RPM	Reverse Polarity Module.	3.0 (1.36)
2-CTM	City Tie Module.	1.0 (0.45)
API-8/232ME	Alphanumeric Pager Interface.	11.0 (5.0)
BPS6A	6.5 Amp Booster Power Supply, 110 V	13.0 (5.9)
BPS10A	10 Amp Booster Power Supply, 110 V	13.0 (5.9)
CDR-3	PSNI Coder Module	1.0 (0.45)