

Intelligent Steam Turbine Performance Testing

Achieve Savings, Increase Efficiency with Smart Wireless Solutions

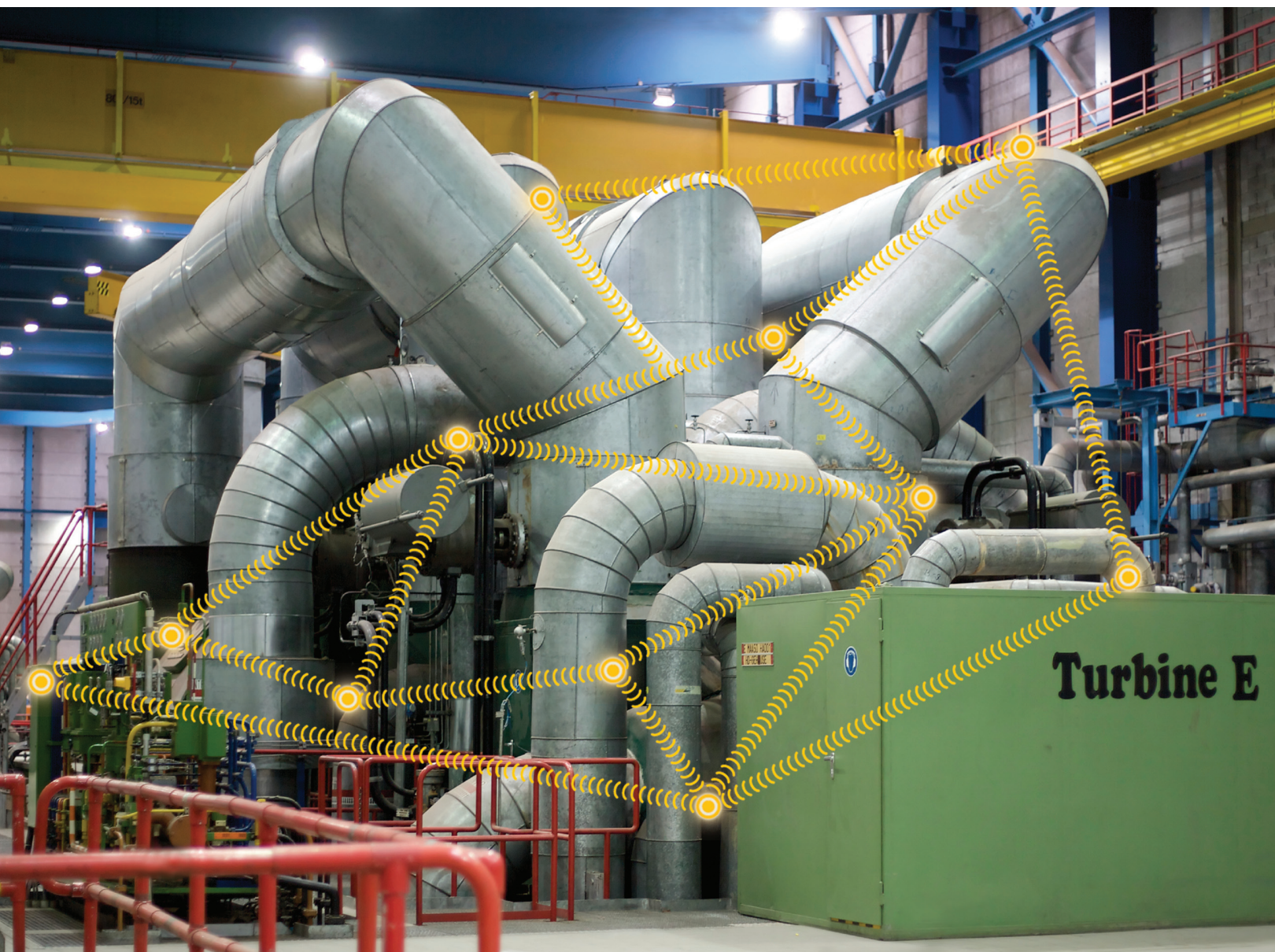

Improve Turbine Performance Testing with Emerson's Smart Wireless Technology



Look to Power Industry Leader for Wireless Advantages

Whether you're an OEM turbine supplier, engineering consultant, or design institute, Emerson Process Management offers innovative Smart Wireless solutions that promise to improve steam turbine performance testing. Testing efficiency is maximized with new wireless turbine performance test setups or wireless upgrades of traditional wired setups.

Maximize Turbine and Plant Performance

Achieve highest turbine performance more effectively with test setups that use Smart Wireless measurement as shown in the diagram on page 3.

The test setups measure inlet and outlet temperature and pressure at startup-acceptance of the turbines, and periodically thereafter. A computer-based thermal efficiency model in the test setup uses the measurement data to track turbine performance against design specifications and identify problematic turbine steam path areas for corrective action to reduce operating costs. Computing may be performed by data loggers and turbine performance test software or turbine performance test modules in plant and enterprise-wide software. Emerson's Global Performance Advisor (GPA) and AMS Suite are two offerings that support ongoing performance of the turbine following the performance test.

Achieve Turbine Test Savings and Automate Test Records

Emerson's Smart Wireless technology delivers up to 30% cost savings and time savings compared with wired approaches. Test accuracy and repeatability are improved since variation in arrangement of cabling and wiring is eliminated. Labor is saved since clipboard rounds and error-prone manual readings are replaced with automated performance test measurement records that are updated and stored historically for each turbine performance test.

CAPEX SAVINGS WITH SMART WIRELESS

- **Materials:**
Use Smart Wireless to avoid costs of cabling, conduit, junction boxes, wiring panels, and cable racks.
- **Engineering:**
Save time and money with Smart Wireless since engineering is minimized, line-of-site communications isn't needed, and costly site surveys are unnecessary.
- **Labor:**
Smart Wireless avoids costs of laying wire.
- **Installation/Commissioning:**
Whereas startup of a traditional turbine performance test can take days, Smart Wireless technology reduces startup time to a few hours.

On use of Smart Wireless networks to determine thermal efficiencies of 140 power plants located throughout Mexico:

"It takes 15 days to install and commission wired instruments, take the readings, and tear down the setup. Then, another week is needed for reporting and other activities before a team can move on to the next plant. In the future, they will be able to cover 75 plants per year, because the on-site work can be done in just 10 days using wireless devices."

Oscar Martinez Mejia, Comisión Federal de Electricidad, Testing Laboratory

Up to 30% cost savings and time savings over wired installation

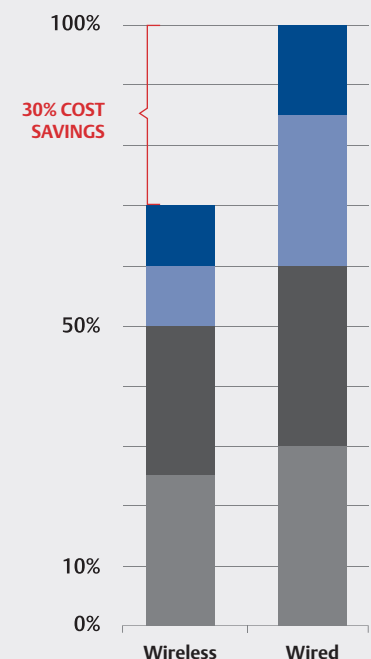



Optimize Turbine Performance Quicker and More Efficiently

Reduce Test Setup/Removal Time

Smart Wireless reduces time required to install the test setup and then remove it when turbine performance testing and maintenance are done. Emerson's AMS Wireless SNAP-ON application insures efficient wireless network installation by using best practices in design of the wireless network. Streamlined test setup and testing helps to achieve high initial turbine performance and periodic re-testing to sustain high performance.

Accelerate the Steam Turbine Performance Testing Process

The steam turbine thermal performance test setup with Smart Wireless technology is quickly connected at the

plant site by the OEM or institute test team of technicians and engineers during initial turbine operation. The turbine is started and run up to plant generation capacity. The test setup's thermal efficiency model determines the heat rate of the unit, efficiency of the turbine, and performance of cycle components. This information helps productivity of the turbine analytical team by enabling focus on problems that need to be addressed to maximize production efficiency.

Sustain Optimum Steam Turbine Performance

Emerson's Smart Wireless test setup measures all pressure and temperature needed for baseline turbine thermal

performance tests which are mandatory for compliance with ANSI/ASME PTC 6 code, and for verification of heat rate guaranteed by the turbine purchase contract. Emerson also offers capabilities for online turbine protection and prediction, in addition to performance monitoring.

An example in the figure shows a schematic of measurement made by Smart Wireless instruments for a PTC 6 turbine performance report of high and intermediate turbine stages.

TYPICAL TURBINE PERFORMANCE MEASUREMENTS MADE BY SMART WIRELESS INSTRUMENTS

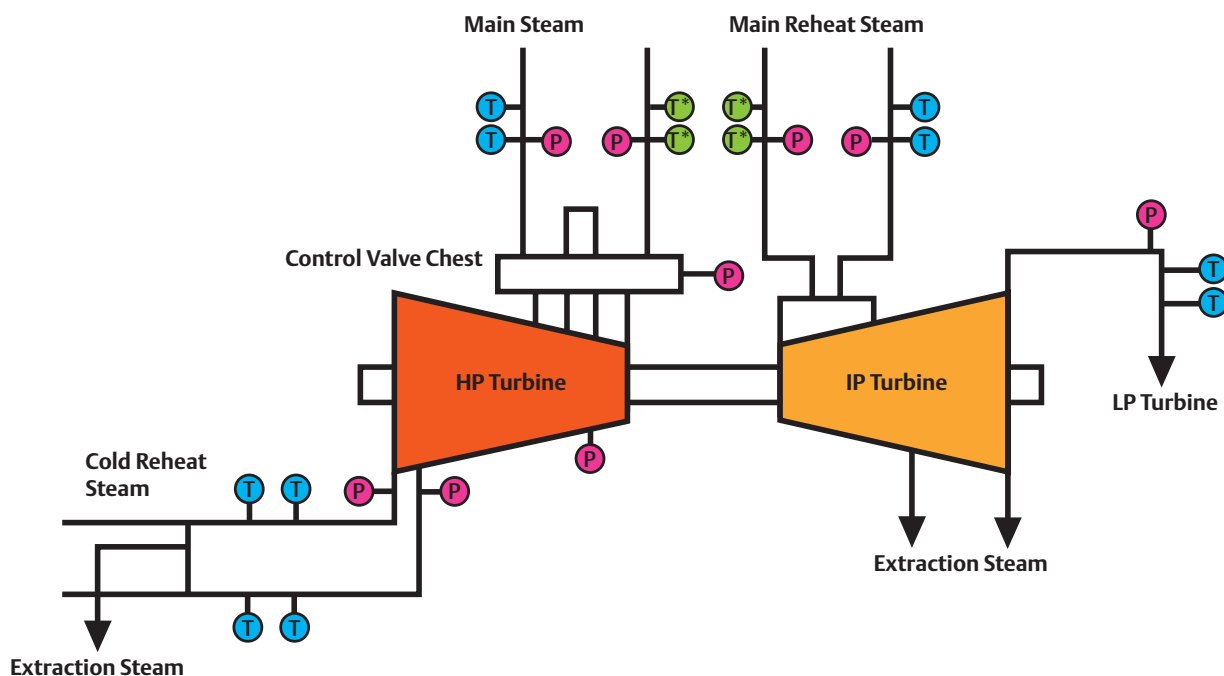

Notes:

denotes Rosemount Wireless High Density Temperature Transmitter

denotes Rosemount Wireless Temperature Transmitter

denotes Rosemount Wireless Pressure Transmitter



HP denotes High Pressure

IP denotes Intermediate Pressure

LP denotes Low Pressure

Acquire Thermal Performance Data Wirelessly



Install and Commission Wireless Devices Quickly and Easily

Digital communications in the turbine performance test setups with wireless technology use self-organizing mesh communications based on the open interoperable IEC 62591 WirelessHART standard. The field network schematic below shows the devices communicating in a typical turbine performance test setup.

Installation is easy since line-of-sight access isn't necessary with the IEC standard mesh networks -- signals easily find their way around obstacles. The wireless devices typically install and

are operating in less than a few hours, transmitting data to Smart Wireless Gateways. The gateways connect to data loggers or to any other plant or enterprise host using OPC, Modbus/TCP, and Modbus RTU. Hosts include Emerson's Ovation™ Expert control system and DeltaV™ digital automation system, both of which have engineering tools and native interface to Smart Wireless components.

Achieve the Reliability of Wired Networks, If Not Better

The IEC 62591 WirelessHART self-organizing mesh network uses other devices in the mesh as alternate

communication paths, providing greater than 99% communications reliability.

Automate Hundreds of Measurements or a Few –Emerson's Smart Wireless is Scalable, Expandable

The test setup using wireless devices is scalable and may only require additional data points for measurements on a 600MW turbine versus a 50MW unit. A single Smart Wireless Gateway accommodates up to 100 Smart Wireless instruments. Multiple gateways can be used if unit separation is required or more than 100 devices are required.

FIELD NETWORK OF SMART WIRELESS DEVICES IN TYPICAL STEAM TURBINE PERFORMANCE TEST SETUP

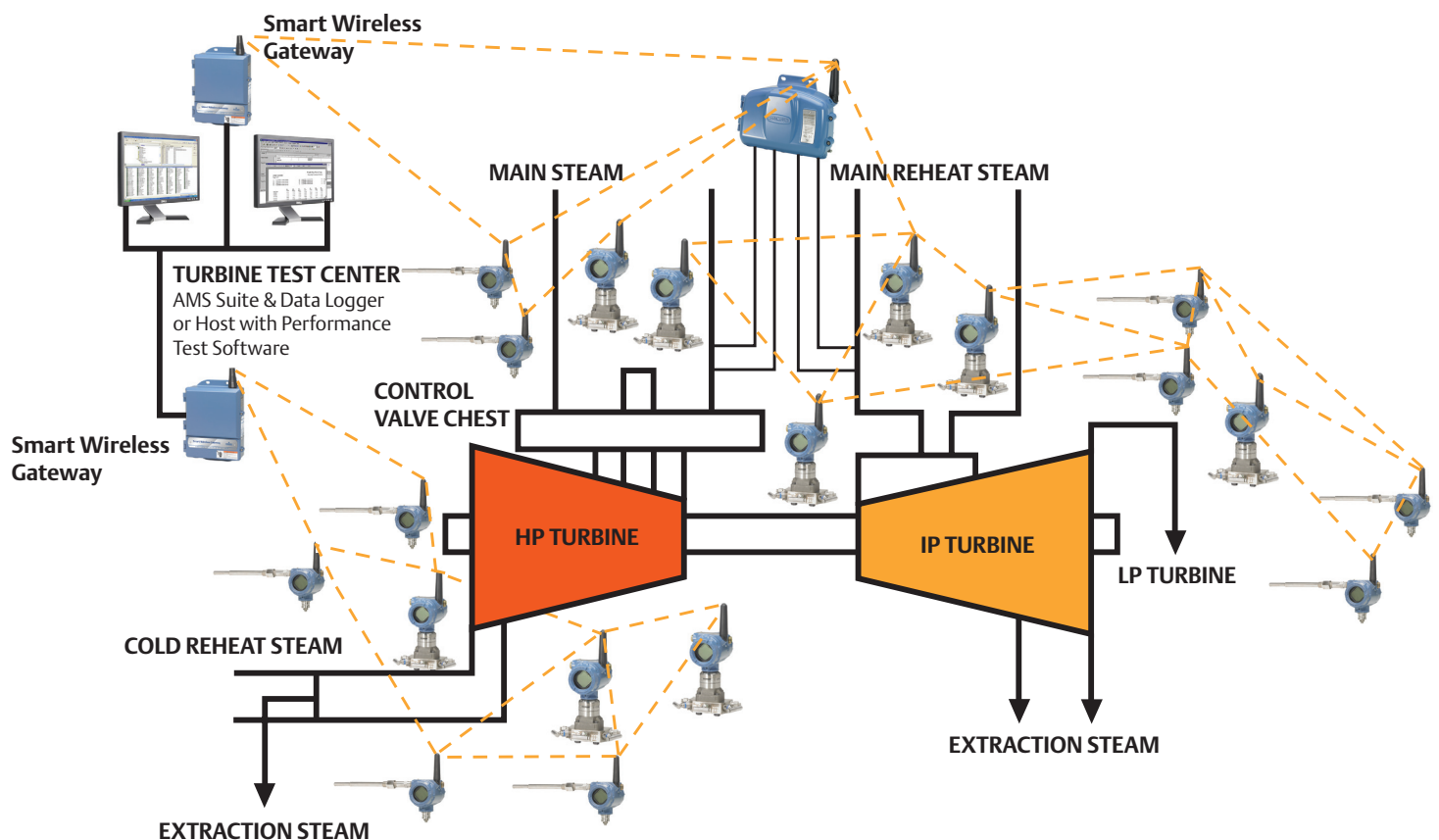

Use Smart Wireless Test Data to Sustain Highest Turbine Performance

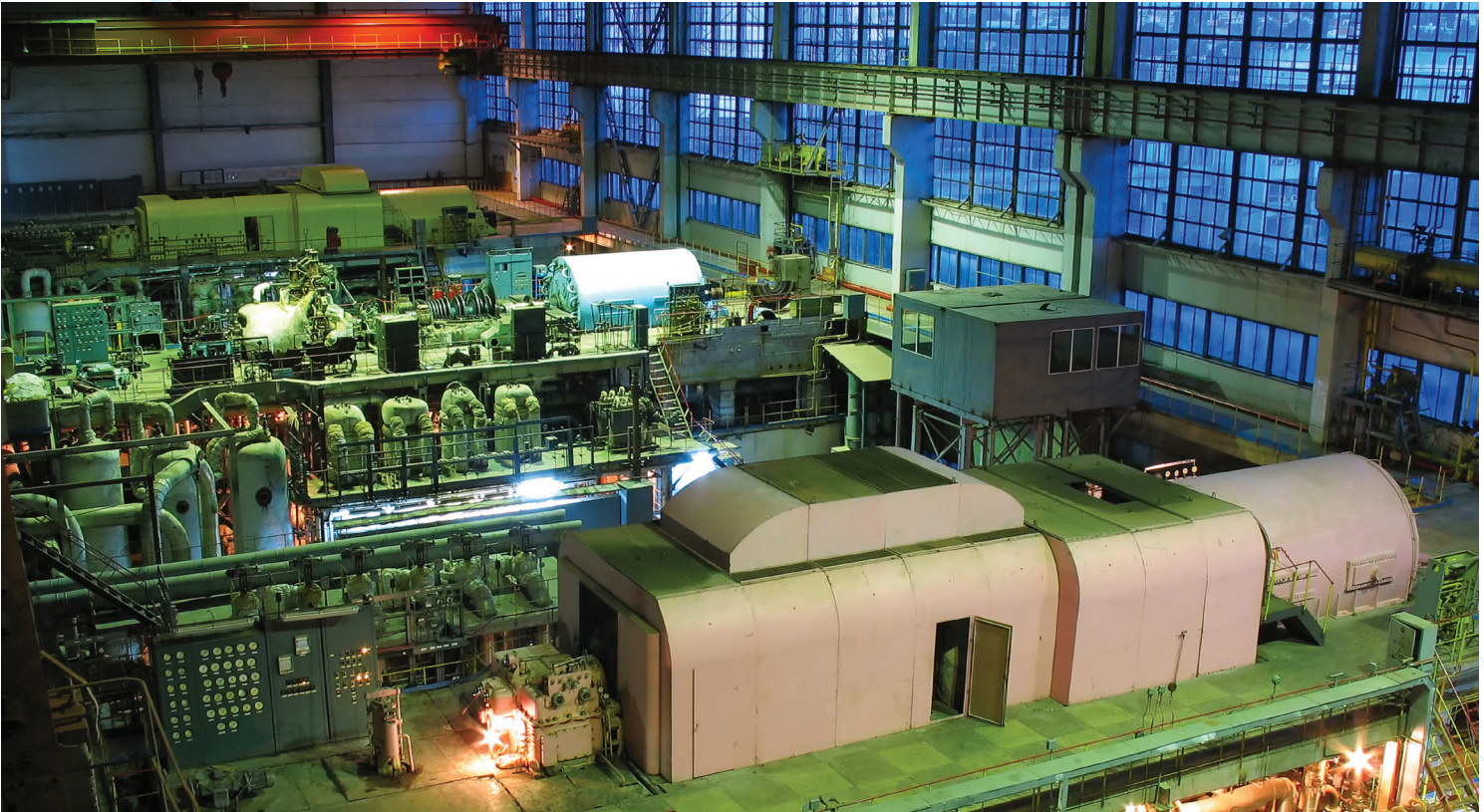

STEAM TURBINES IN POWER PLANT

Automate Test Setup Configuration and Maintenance

Emerson's AMS Suite software automates configuration of Smart Wireless instruments and storage of settings to ensure consistency and repeatability of the turbine performance test setup. AMS Suite also collects diagnostics from instruments in the wireless network to monitor and maintain health of the test setup and turbine operation.

Monitor and Maintain the Entire Steam Path

The steam turbine measurement required by ANSI/ASME PTC 6 provide the necessary data for use by the turbine team to analyze performance of components in the turbine steam path including the steam turbine, main steam header, reheat steam, condenser, feedwater heaters, and other components. The data is used in thermal efficiency equations to determine turbine cycle heat rate, kilowatt capacity, high pressure (HP) and intermediate pressure

(IP) section efficiencies, turbine stage pressures and flow capacities.

Trend data from the turbine testing identifies degradation which helps to inform turbine maintenance teams of likely causes. With this knowledge, teams can better schedule and prepare for maintenance outages when they can do further analysis and troubleshooting of issues with blades, nozzles, buckets, tip seals, deaerators, condensers, feedwater heaters and more.

Join Thousands Using Smart Wireless Solutions



Customer Installations Illustrate Scalability and Flexibility

Smart Wireless solutions are proven, being used across industries by thousands of customers. These include turbine test setups ranging from smaller turbines delivering a few megawatts to larger units delivering hundreds of megawatts.

Test setups with Smart Wireless technology are scalable and flexible, adapting to the measurement needs of any turbine. For example, a customer installation for a smaller (5 to 60 megawatt) turbine includes AMS Suite for configuration and maintenance, and the following:

- 4 Smart Wireless Gateways for field network communications
- 68 Wireless Temperature Transmitters for turbine area measurement
- 31 Wireless Pressure Transmitters for

inlet and outlet steam measurement, plus bearing lube oil monitoring

- 15 Wireless Discrete Transmitters for contact monitoring
- 1 Wireless Differential Pressure Transmitter to measure inlet steam flow

Smart Wireless has the flexibility to match various sizes of test application. Customer installations have included as few as 2 wireless pressure and temperature measurements. Others comprised 36 pressure and 15 high density temperature measurements. Capacity and layout flexibility is virtually unlimited.

Emerson's Smart Wireless Family Expands Applications

Emerson's wide range of Smart Wireless devices makes it easy to expand functionality. For example, further

turbine and generator monitoring may be added, including the following:

- Vibration on turbine casing – measures blade pass frequency which can be used to determine turbine design impact on flow disruption
- Skin temperature on turbine casing – there are typically around 40-50 temperature points per medium size turbine
- Generator winding temperature – there are more than 70 temperature points per generator
- Bearing temperature and vibration – both driving end and non driving end typically house around 10 bearing points
- Shaft vibration – measurement sent to Emerson's online turbine protection and prediction system

Users Tap Complete Range of Power Plant Automation Solutions

Automation of turbine performance testing is part of Emerson's leadership in total power plant automation solutions using wired, bussed and wireless technology to enable smarter electricity generation. Emerson currently supports installations that produce more than 725 gigawatts of the world's power capacity. Contract examples are as follows:

Emerson to automate two 1000-MW ultra-supercritical units at Anhui Tongling power plant in central China
Unifying control of boiler, turbine and major plant equipment to improve unit stability, responsiveness and thermal efficiencies

IRPC's new combined heat and power plant in Thailand to utilize Emerson's PlantWeb™ digital architecture with Ovation system to control critical processes
Ovation technology will link new CHP plant with largest integrated petrochemical complex in southeast Asia, enabling enhanced efficiency and productivity

Emerson to modernize instrumentation, control and electrical systems at Europe's largest thermal power plant
Automation technology and services will help improve efficiency at PGE Belchatow power plant in Poland

Emerson upgrades gas and steam turbine controls at Mexico's Felipe Carrillo Puerto combined-cycle power plant
Replacing existing controls on Siemens V.84.2 and Kraftwerk Siemens turbines with Ovation technology expected to boost reliability and availability of 220-MW plant



Start with Emerson and Smart Wireless today

EMERSON'S SMART WIRELESS FAMILY INCLUDES A BROAD RANGE OF INSTRUMENTATION



Getting started is Easy

Contact and challenge us. Request that our power industry wireless experts demonstrate the unique advantages of Smart Wireless technology with instruments and controls tailored to your steam turbine performance testing application.

Request a proposal for improving an existing turbine performance test setup with Smart Wireless technology, or developing a new test setup. Your test setup will include:

- **Field Instruments:**
Pressure and temperature instruments chosen from our broad range of Smart Wireless instrumentation.
- **Gateways:**
Smart Wireless Gateways that connect the wireless field instruments with host systems and data applications using industry leading security, scalability, and data reliability.

- **Configuration Management and Maintenance:**
AMS Suite software that configures all Smart Wireless instruments and stores the configuration for repeatability of future uses, plus collects diagnostics that monitor instrumentation and process health.
- **Services:**
SmartStart™ Services are available to help you with your first Smart Wireless startup, including a full network health assessment to ensure robust wireless communications plus verification of device functionality through your chosen output (OPC, Modbus TCP/IP, and Modbus RTU). SmartStart Services include the startup and commissioning of wireless industrial process control systems, technical support services, troubleshooting services, and software installation.

Integration services combine turbine performance test data with the thermal performance software of your data logger or host, and as needed with the plant host such as Emerson's Ovation or DeltaV systems, and with AMS Suite software.

FOR A LIST OF LOCATIONS IN
THE EMERSON GLOBAL NETWORK, VISIT
EMERSONPROCESS.COM

OTHER RESOURCES:

Brochures:

Smart Wireless Field Network Solutions
Smart Wireless Solutions for Plant Operations
Smart Wireless THUM™ Adapter
Smart Wireless Field Starter Kit
The Virtual Wireless Plant Tour

Smart Wireless Internet:

www.EmersonProcess.com/SmartWireless

Power & Water Solutions Internet:

www.EmersonProcess-PowerWater.com

Wireless signal superimposed on the cover photo is for illustration only.

The Emerson logo is a trademark and service mark of Emerson Electric Co. Ovation, THUM, AMS Suite, DeltaV, SNAP-ON, Rosemount, PlantWeb and SmartStart are marks of one of the Emerson Process Management family of companies. All other marks are property of their respective owners.

The contents of this publication are presented for information purposes only, and while effort has been made to ensure their accuracy, they are not to be construed as warranties or guarantees, express or implied, regarding the products or service described wherein or their use or applicability. All sales are governed by our terms and conditions, which are available on request. We reserve the right to modify or improve the designs or specifications of our products at any time without notice.

©2011 Emerson Process Management. All rights reserved.

**Emerson Process Management
North America**

12301 Research Blvd.
Research Park Plaza, Building III
Austin, TX 78759
USA
Tel +1 512 835 2190
Fax +1 512 834 7600
www.EmersonProcess.com

**Emerson Process Management
Europe**

Blegistrasse 23
P.O. Box 1046
CH 6341 Baar
Switzerland
Tel +41 0 41 768 6111
Fax +41 0 41 768 6300

**Emerson Process Management
Asia Pacific**

1 Pandan Crescent
Singapore 128461
Tel +65 6777 8211
Fax +65 6777 0947

**Emerson Process Management
Latin America**

8100 Weat Florissant Avenue
Annex K
St. Louis, Mo 63136
USA
Tel +1 314 553 1847
Fax +1 314 553 1982

**Emerson FZE
Middle East & Africa**

P.O. Box 17033
Jebel Ali Free Zone
Dubai, UAE
Tel +971 4811 8100
Fax +971 4886 5465

