



Installation Instructions for:

*Radix*

INTERCOOLED SUPERCHARGER SYSTEM  
2005-2006 6.0L  
Chevrolet SSR Truck



Step-by-step instructions for installing the best in  
supercharger systems.



**ATTENTION!**  
**Your MAGNA CHARGER intercooler kit**  
**is sensitive to corrosion!**  
**Take care of it by using 50/50**  
**anti-freeze with de-ionized water.**

Magnuson Products Inc  
1990 Knoll Drive, Ventura, CA. 93003  
(805) 289-0044 \* (805) 677-4897 fax  
magnusonproducts.com \* magnacharger.com

# INSTALLATION MANUAL

Magna Charger  
Radix Intercooled Supercharger System  
GM 6.0 liter engines

We encourage you to read this manual thoroughly before you begin work, for a few reasons:

A quick parts check to make certain your kit is complete (see shipper parts list in this manual). If you discover shipping damage or shortage, please call our office immediately.















Take a look at exactly what you are going to need in terms of tools, time, and experience.

Review our limited warranty with care.

Make sure to have 91 or higher octane fuel in the tank.

When unpacking the supercharger kit DO NOT lift the supercharger assembly by the black plastic bypass actuator. This is pre-set from the factory and can be altered if used as a lifting point!

## Tools Required

-  Safety glasses
-  Metric wrench set
-  1/4" drill bit
-  1/4", 3/8", & 1/2" drive metric socket set (standard and deep)
-  8mm hex (Allen) wrench
-  3/8" and 1/2" drive foot pound and inch pound torque wrenches
-  Belt tensioner wrench or 1/2" breaker bar
-  7/32" socket
-  Drill and 5/16" drill bit
-  Phillips and flat head screwdrivers
-  Fuel quick disconnect tools (included in kit)
-  E5 internal Torx socket
-  Small or angled 3/8" drill motor
-  Drain pan
-  Compressed air

# Important

Our Magna Charger kits are designed for stock engines, with stock components, in good mechanical condition only. Installation on worn or damaged engines is not recommended and may result in engine failure, for which we naturally can't be responsible. Magna Charger is not responsible for the engine or consequential damages.

Aftermarket engine re-calibration devices that modify fuel and spark curve (i.e.. programmers) are not recommended and may cause engine damage or failure. If you have any questions, call us!



Caution: Relieve the fuel system pressure before servicing fuel system components in order to reduce the risk of fire and personal injury. After relieving the system pressure, a small amount of fuel may be released when servicing the fuel lines or connections. In order to reduce the risk of personal injury, cover the regulator and fuel line fittings with a shop towel before disconnecting. This will catch any fuel that may leak out. Place the towel in an approved container when the job is complete, and of course, no smoking.

Magna Charger strongly recommends the following:

- Clean your engine compartment before starting any engine disassembly.
- You must have a clean fuel filter - check and replace as needed before installation.
- You must have a clean air filter - replace every 10,000 miles.
- OE type / Stock spark plugs and stock plug gap is recommended.
- Start with and use only 91 octane fuel or higher.

After you finish your installation and road test your vehicle, please fill out and mail the limited warranty card, so we can add you to our files (this is important for your protection).



Please remember to follow all safety rules that apply when working, including:



Wear eye protection at all times.



Do not work on a hot engine.



Be careful around fuel - use shop towels to catch any spills and dispose of towels properly.



1. Under the right (passenger side) rear corner of the vehicle, remove the two battery access panel bolts with a 10mm socket wrench.



2. With a 8mm wrench disconnect the negative (-) battery cable and wrap the terminal end with electrical tape. Ensure that the cable is far enough away from the battery that it does not accidentally touch the battery and make contact during the installation.



3. Locate the vehicles computer just below the windshield washer reservoir filler neck. Remove the two bracket bolts with a 10mm socket wrench.

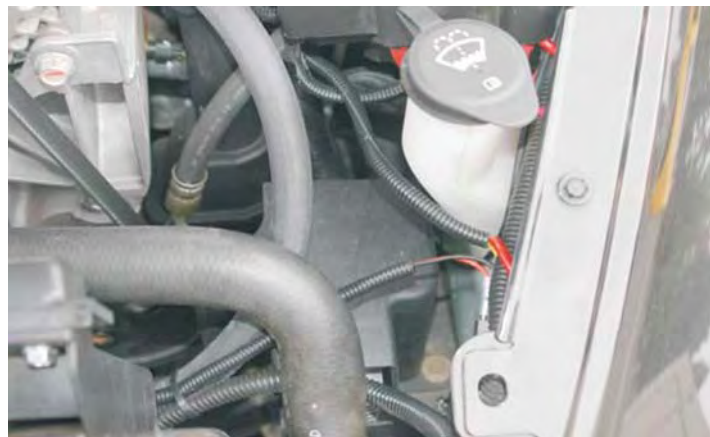



4. Remove the two push-rivets from the computer cover by pulling up on the center heads of the rivet and then pulling up on the base.



5. Remove the cover from the computer.



6. There are three computer connectors, Grey, Black and Blue. Remove the connectors by first removing the Red locking key, then pushing in on the Black cover and pushing the Grey latch down.



7. The computer connectors can be removed when the latch is pushed down and the red tail of the latch is visible on the end of the connector.



8. Release the computer module by lifting the two retaining hooks and lifting the computer out and up.



9. Note: If your vehicle has a automatic transmission, you will also need to remove the transmission control computer located on the back side of the mounting bracket.



10. Here are the shipping materials supplied to quickly return the vehicle computers to Magnuson Products Inc.



11. Place the computers into the plastic bag supplied and then wrap it in the bubble-pack sheet and seal the box.



12. Completely fill out the pre-paid shipping form supplied and then remove the adhesive label on the third page, placing it on the top of the box. Take the box to your nearest UPS office to be returned to Magnuson Products Inc. Magnuson will then re-program the computer and quickly return it to you via UPS.



13. On the right (passenger) side of the intake manifold, locate the fuel pressure test port. **CAUTION!** The fuel in the system is under pressure! Relieve the pressure in the fuel system by depressing the check valve with a screwdriver and collecting the fuel with a shop towel.



14. Relieve the pressure in the fuel tank by removing the fuel filler cap.



15. When the engine is cool, remove the radiator reservoir cap. Do not remove the cap if the engine is still hot or serious injury may result.





16. Remove the SSR badge from the engine cover with a straight blade screwdriver by gently prying it up on the front edge.



17. Remove the engine cover's four fasteners with a 8mm socket wrench.



18. Remove the engine cover completely, as it and the SSR badge will not be reused.



19. Loosen the air filter bellows clamp and the Mass Air Flow meter (MAF) clamp with a 8mm nut driver.





20. Unplug the Mass Air Flow meter (MAF) connector by pulling out the gray release trigger and the squeezing the connector.



21. Remove the two plastic push-lock rivets from the air filter apron. Do this by gently prying the center of the rivet up with a straight blade screwdriver and then removing the rivets completely.



22. Remove the nuts and washers from each side of the air filter apron with a 10mm socket wrench.



23. Remove the air filter apron.



24. Remove the two remaining bolts securing the air filter with a 10mm socket wrench.



25. Remove the air filter assembly complete and then separate the MAF and bellows from the air filter cover.



26. As it will be necessary to drain the cooling system and most SSR trucks have no drain on the radiator, loosen the two bolts that secure the thermostat assembly with a 10mm socket wrench. Catch the coolant in a drain pan for reuse. Re-tighten the thermostat bolts after draining is complete.



27. Remove the PCV vent pipe on the throttle body inlet bellows.





28. Open the large electrical harness retainer clip, then using a 10mm socket wrench remove the bolts holding the plastic wire harness retainer to the intake manifold



29. Using a 10mm socket wrench, remove the three bolts that fasten the cover support bracket from the top of the intake manifold.



30. Disconnect the eight fuel injector connections by gently pulling up on the gray plastic release trigger on the connector and then pulling firmly on the connector itself. Disconnect the coil pack connector and then the four wire harness clips that secure the harness to the right side of the engine.



31. Disconnect Electric Throttle Control (ETC) connector from the throttle body by removing the gray plastic locking tab first, then squeeze and pull free the ETC connector itself.





32. At the rear of the of the intake manifold disconnect the Manifold Absolute Pressure (MAP) sensor connector by gently raising the gray plastic retaining clip and then pull free the connector.



33. Disconnect the evaporative purge solenoid EVAP connector located on the top of the driver (left) side fuel rail, by raising the black plastic retaining clip and then pull free the connector itself.



34. Disconnect the Air Conditioning (A/C) pressure connector from the pressure switch and from the clip on the cylinder head.



35. **THIS STEP IS IMPORTANT!** Cover the Air Conditioning (A/C) pressure switch with masking tape to protect it during the supercharger installation process.



35. Lift the electrical harness from the top of the engine and set off to the drivers (left) side.



36. Disconnect the EVAP vent tube from the solenoid by squeezing the retainer, then release the tube from the solenoid located on the top of the fuel rail on the driver (left) side. Follow the same procedure on the other end of the vent tube at the firewall and remove the tube from the vehicle.

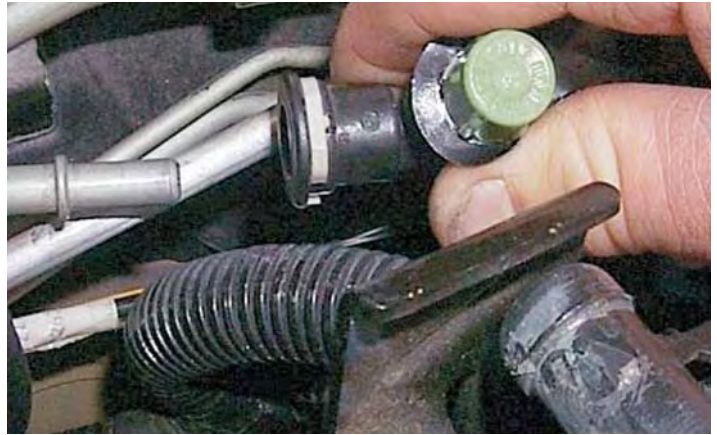

37. Remove the Positive Crankcase Vacuum (PCV) hose from the intake manifold on driver side.



38. Remove the power brake hose and check valve from the brake booster.





39. With the fuel line disconnect tool supplied, remove the fuel lines from the fuel rail. Caution! The system may be under pressure. Avoid open flame or other sources of ignition. 2005 vehicles will have only one fuel line.



40. Using a 8mm socket wrench remove the ten intake manifold bolts.



41. Carefully remove the intake manifold assembly and set aside.



42. Using a vacuum cleaner, remove any dirt or debris from the intake port area. (Be careful not to get any dirt in the intake ports.) Note: 6.0L engines will not have the Knock sensor wells on the engine valley cover as shown.





43. Cover the intake ports with tape or clean rags to keep dirt and objects from entering the engine. (Remember, be clean.)

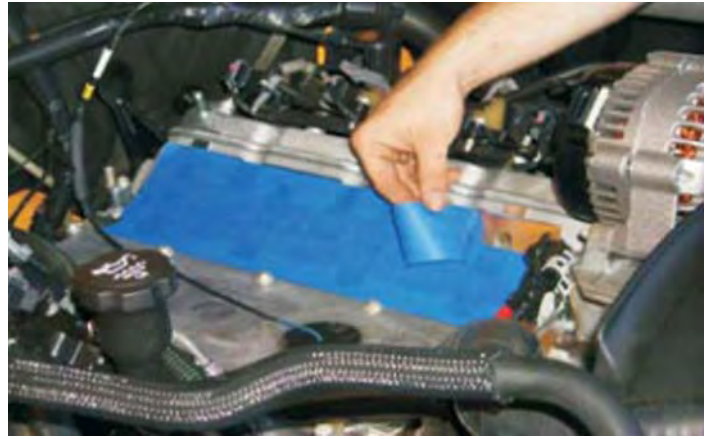

44. Using a 10mm socket wrench remove the two coolant vent pipe bolts.



45. Remove the vent pipe assembly. (Make sure that the O-ring gaskets did not stick to the cylinder heads, if so remove them.)



46. Using a 15mm tensioner wrench or breaker bar, remove the stock serpentine belt from the vehicle. The belt will not be reused.



47. Using a 15mm socket wrench remove the three bolts holding the factory belt tensioner to the bracket and remove the tensioner.



48. Disconnect the positive (+) battery cable from the back of the alternator with a 10mm wrench.



49. Disconnect the positive (+) battery cable from the back of the alternator with a 10mm wrench. Use a 15mm socket wrench remove the two bolts holding the alternator to the alternator bracket and then remove the alternator.



50. It will be necessary to make clearance on the alternator mount casting for the new manifold to fit properly. The new manifold should not touch the alternator mount. These modifications can be easily done with the mount in place.





51. For clarity this mount is shown removed from the engine. Using a marking pen and a straight edge, mark a line as shown on the top surface of the of the alternator mount. Start the line at the drivers (left) rear corner of the idler mount and then to the right rear corner of the alternator mount. Continue the line at an angle for a distance of about 1-1/4" to the back edge of the casting behind the alternator mount. Using a suitable grinder and eye protection, remove the material up to the line.



52. On the back surface of the alternator mount, remove the shaded area as shown.



53. Here is what your finished alternator mount should look like.



54. Install the new O-ring gaskets onto the coolant vent pipe bases using some of the lubricant supplied.





55. Using the stock bolts removed in step 45 install the new coolant vent pipe supplied. Ensure that the O-ring gaskets are installed correctly. Torque the bolts with a torque wrench and 10mm socket to 106 lb-in.

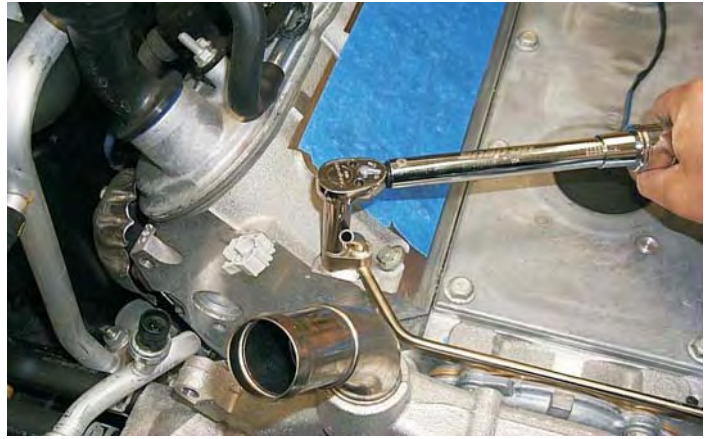

56. Using the supplied 3/8" hose, connect a 15" length to the PCV valve as shown and lay the other end of the hose off to the drivers side, out of the way. (To be connected in a later step.)



57. Remove the rubber cover and then the electrical connector from the Oil Pressure Transmitter.



58. Remove the Oil Pressure Transmitter with a 28mm socket wrench.



59. Remove the engine valley cover and gasket by removing the ten bolts with a ratchet and 13mm socket.



60. The gasket will be reused, the original valley cover and bolts will not. Inspect the gasket for any damage and then reinstall. Note: It will only fit correctly in one position.



61. Using a small straight blade screwdriver, remove the 8 O-rings from the underside of the engine valley cover and transfer them to the grooves in the bottom of the new cover.

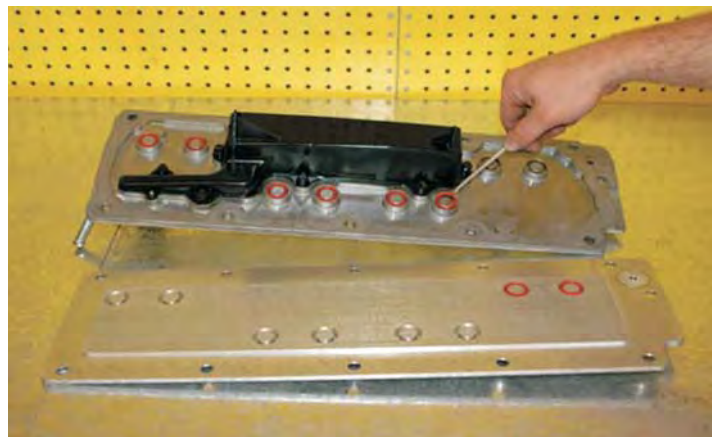

62. Install the new engine valley cover and flathead bolts supplied with a 5mm Allen socket and torque the bolts to 18 lb-ft. Insert the six O-rings in the recesses in the new valley cover.





63. Install the Oil Pressure Transmitter in the new val-  
ley cover with a 28mm socket and torque it to 15 lb-ft.



64. Re-connect the oil pressure transmitter electrical  
connector.

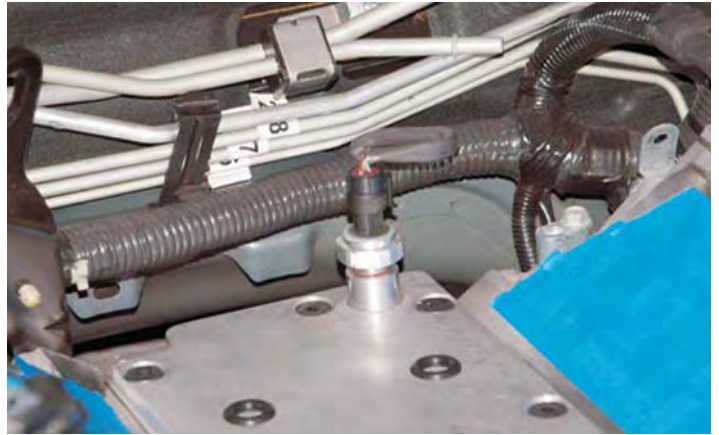

65. Using a 13mm wrench remove the bolt securing  
the attachment clip for the fuel line.



66. Remove the steel bracket on the rear of the left  
cylinder head with a 15mm wrench, the bracket will  
not be reused.



67. Remove the two bolts securing the firewall seam cover from the firewall with a 10mm socket wrench.

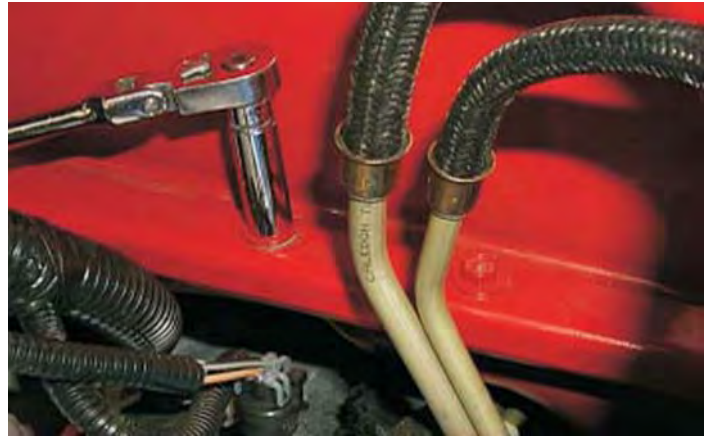

68. From the hole nearest the center of the seam cover, measure over 1" and make a line across the cover.



69. Cut the seam cover in two pieces with a suitable saw.



70. Re-install the longer piece of the seam cover with its fasteners in the original location.

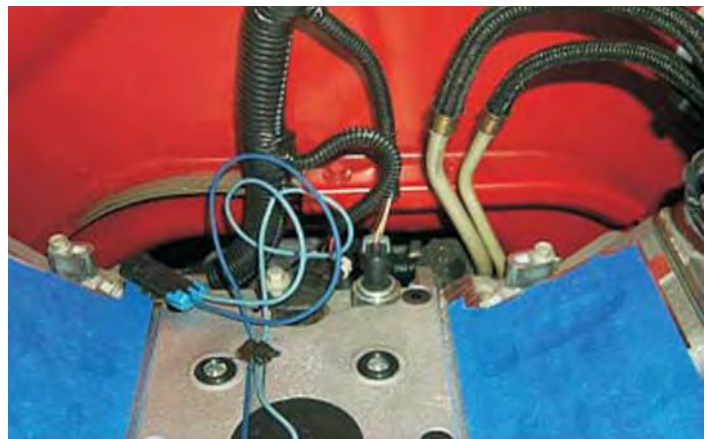



71. Remove the upper radiator hose at the upper water pump outlet.



72. The original water pump outlet tube will need to be replaced. Remove the outlet by cutting it off. Use a suitable hacksaw and cut it off approximately 1" above the water pump casting.



73. Remove the remaining stub of the outlet in the pump casting by collapsing it within itself. The object is to reduce the diameter of the stub by collapsing it not to cut it. Use a dull chisel or wide drift with a hammer to drive one side of the stub across and down to the other side. Take care not to damage or scratch the outlet bore of the water pump casting.

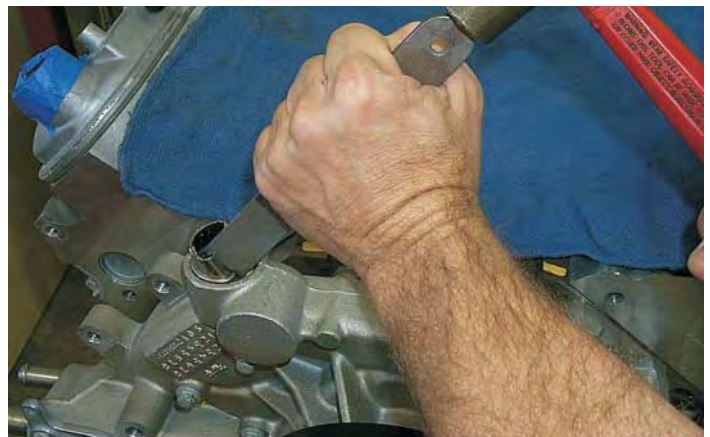

74. Use a pair of pliers to pull the collapsed stub straight up and out. Do not twist the stub as you pull it out, as this will scratch the outlet bore of the water pump casting.



75. Here are the new components for the water pump outlet and tensioner assembly.

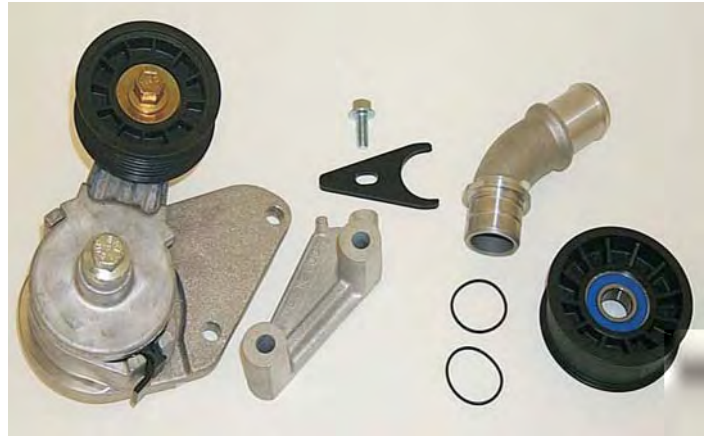

76. In the original tensioner location, mount the new outlet base with the new tensioner assembly on top of it. Use only the two long mounting bolts, the third shorter bolt will not be reused. Replace the factory idler pulley mounted on the alternator bracket with the new pulley supplied. Tighten the mounting bolts and with a 15mm socket and torque wrench to 40 lb-ft



77. Install the two O-rings supplied into the grooves on the new water pump outlet.



78. Using some of the grease supplied, gently install the new outlet in to the bore of the water pump casting.





80. Install the outlet retainer and 8 x 20mm bolt into the tensioner base. Do not tighten the retainer bolt yet as final positioning will be done in a later step. Tighten the bolt finger tight for now.



81. Install the upper radiator hose and clamp onto the new water pump outlet.



82. Remove the stock MAP sensor from the stock intake manifold by pulling back on the two tabs and lifting the sensor out. Ensure that the orange MAP sensor seal is not damaged, as it will be used.



83. Put some lubricant on the MAP sensor seal and press the MAP sensor into the provided hole in the supercharger manifold as shown.



84. Using a 4mm Allen wrench, install the MAP sensor retaining clip with the provided 6mm button head screw as shown.



85. Install the intake manifold gaskets supplied into the recesses on the supercharger manifold face. Ensure that the gaskets are fully seated.



86. Assemble the solenoid bracket and bolts onto the fuel manifold.



87. Using some of the lubricant supplied, install the O-ring into the recess on the fuel rail. Install the fuel manifold and bracket onto the fuel rail. Take care not to pinch the O-ring.

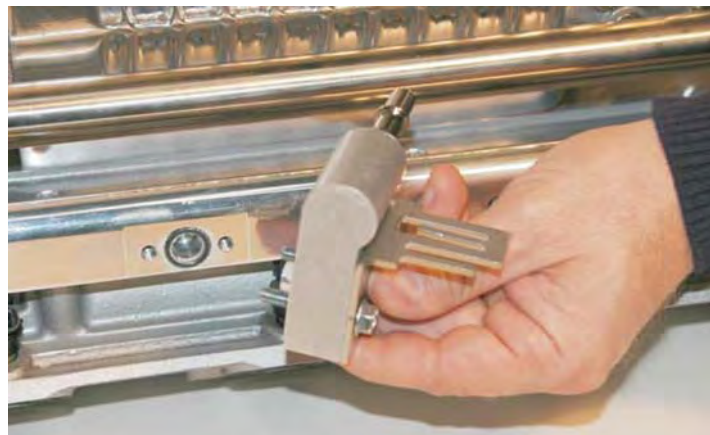



88. Torque the fuel manifold bolts to 106 in-lbs using a 10mm socket and torque wrench.



89. Using a 10mm socket wrench remove the stock throttle body from the stock intake manifold.



90. Next, using a #5 internal Torx socket remove the mounting studs from the stock intake manifold.



91. Remove the throttle body O-ring from the intake manifold.



92. Install the throttle body O-ring into the inlet manifold groove on the supercharger.



93. Install the studs removed in the previous step into the new supercharger inlet manifold using a #5 internal Torx socket and wrench.



94. Mount the throttle body using the original nuts and bolts. Torque to 106 in-lbs.



95. Remove tape from the cylinder head port faces and lubricate the surfaces with silicone spray or soapy water. Do not use any petroleum based products that could damage the port gaskets.





96. Using a assistant, carefully lower the supercharger and manifold assembly into place. Ensure that the two metal fuel lines at the firewall are out of the way. Do not use the black bypass canister to lift the assembly by or damage will result. Use care not to damage the port gaskets.



97. Remove the split-looms that support some of the manifold to cylinder head bolts. Start all ten bolts by hand to ensure proper alignment of the manifold.



98. Torque all ten bolts that secure the manifold to the cylinder heads gradually and evenly to a torque of 89 lb-in. Use a 10mm socket and torque wrench.



99. Push the fuel line connectors on to the fuel manifold. 2005 vehicles will have only one fuel line connection. Ensure that the fuel line is pushed all the way on. Pull on the connectors to check that they are secure, you should not be able to remove the connector unless you use the removal tool.



100. Remove the EVAP solenoid from the mounting bracket on the driver side fuel rail.



101. Connect the original passenger side PCV line back into place on the inlet bellows.



102. Locate the vent tube previously removed from the tube from the vehicle.



103. Using a sharp knife, cut the plastic tube at the ends to free the two EVAP fittings.





104. Assemble a new EVAP hose using the fittings and a 10" long piece of the 5/16" vapor hose with the #4 hose clamps supplied.



105. Connect the newly assembled EVAP line to the end of the solenoid with the electrical connection. Connect the other end of the solenoid to the center barb of the "T" connector using 7" length of the 5/16" Vapor hose and a #4 clamp. At the front of the "T" fitting, connect a 8" length of 3/8" vapor hose. This hose will form the Positive Crankcase Vent (PCV) line and connect to the supercharger inlet manifold. To the remaining (rear) barb of the "T" fitting, connect the PCV line installed on the barb from the rear of the driver (left) side valve cover in step 56.



106. Install the PCV hose from the front of the "T" fitting on the middle barb of the inlet manifold.



107. Insert the new vacuum check valve into the end of the new 11/32" Vacuum hose.



108. Connect the other end of the vacuum hose to the remaining barb on the side of the inlet manifold.

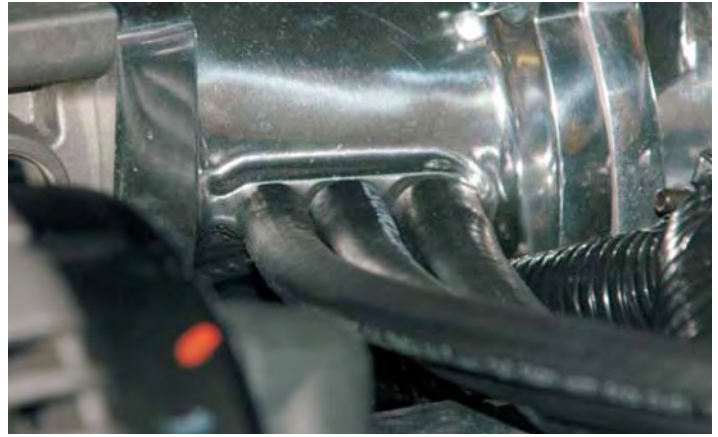

109. Install the new check valve into the brake booster.



110. Using a 10mm socket wrench, remove the two bolts that secure the air filter cover to the air box assembly.



111. Inspect the air filter, it should be replaced every 10,000 miles.





112. Assemble the air box with the new filter cover supplied.



113. Secure the new filter cover with the original fasteners and a 10mm wrench.



114. Install the MAF and bellows to the new air filter cover.



115. Reinstall the bellows to the throttle body and then re-attach the air filter box and its apron to the vehicle.



116. Here is the intercooler reservoir and its mounting hardware.

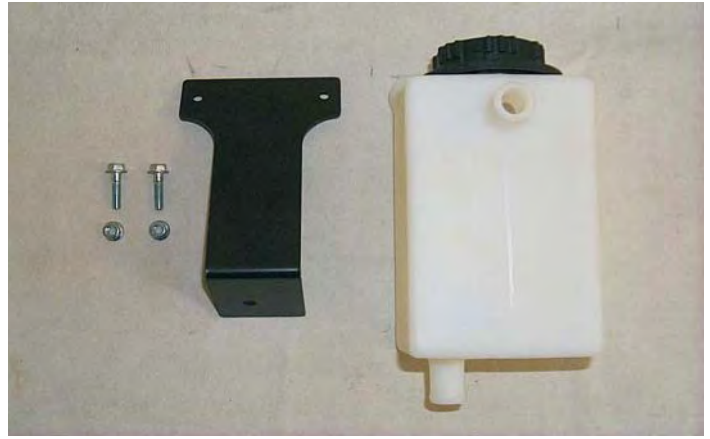

117. Assemble the reservoir to the mounting bracket using the two 6 x 20mm bolts and nuts supplied. Position the bracket so that the lower mounting tab is pointing away from the reservoir. Tighten securely with a 10mm socket wrench.

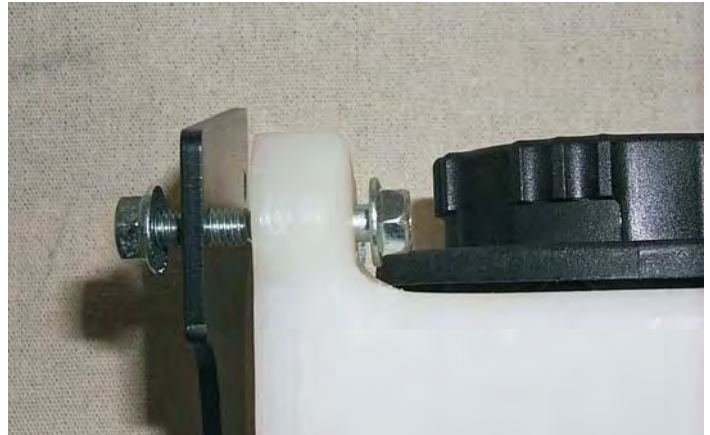

118. Remove the bolt and washer that secures the front mounting foot of the radiator coolant tank. Insert the lower mounting tab of the intercooler reservoir under the foot of the coolant tank and reinstall the bolt and washer. Tighten the bolt securely with a 10mm socket wrench.



119. Here is the installed intercooler reservoir and bracket on the vehicle.





120. Here is the intercooler heat exchanger and its mounting components.



121. Install two of the round-headed carriage bolts supplied into both channels on the sides of the heat exchanger. The square portion of the bolt shaft must be aligned with the side of the channel.



122. Align the bolts with the holes in the vertical mounting brackets.



123. Torque the mounting nuts to 18 ft-lbs with a 13mm torque wrench.



124. Install the cross member to the vertical brackets with the 8 x 20mm bolts supplied. Tighten securely with a 13mm wrench.



125. Here is the completed heat exchanger ready for installation. Note: The heat exchanger barbs and long end of the cross member are on the right side.

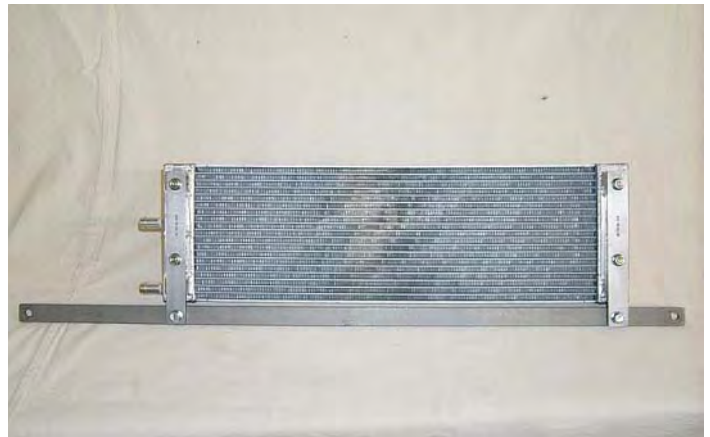

126. Install the heat exchanger assembly by sliding the complete assembly up from underneath the vehicle between the power steering cooler and the A/C condenser. The nose of the vehicle has been removed for clarity only. You do not have to remove the nose to install the heat exchanger.



127. Using a 15mm wrench, remove the mounting bolts on both sides of the vehicle that are located below the power steering cooler bracket. Slide the heat exchanger up into position and then attach its mounting bracket with the original mounting bolts.





128. Here is the mounting bolt on the right side of the vehicle. Note: The heat exchanger barbs must be pointing to this side.

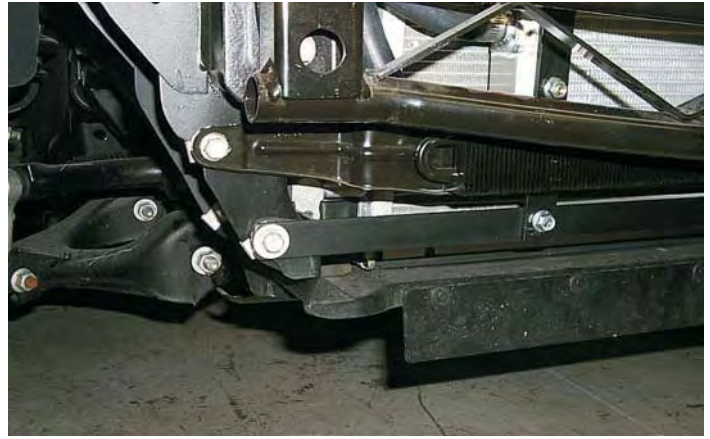

129. To create a space for the coolant lines to pass through the heat exchanger, you must remove the molded foam block located between the side of the radiator and the body. To remove the molded block, push it free with a straight blade screwdriver between the fender and the radiator support.



130. After pushing the molded foam block, pull it out from the engine compartment. The foam block will not be reused.



131. Removing the molded foam block creates an opening between the radiator and the fender well for the intercooler coolant lines to pass. The line from the pump to the heat exchanger and from the heat exchanger to the coolant manifold will pass through this opening.



132. Here is the intercooler pump, mounting clamp, hardware, wiring and reservoir to pump hose.



133. The intercooler pump will mount in the right side of the engine compartment next to the battery cable junction box. Note: The elongated hole in the panel.



134. From underneath the vehicle on the right side locate the elongated hole. Approximately 1" back from the hole drill a 1/4" hole to mount the pump. Place the mounting clamp around the pump body and then pass the new 6 x 20mm bolt through the pump mounting clamp and then through the hole. Secure the bolt with the new nut and tighten securely with a 10mm wrench.



135. Starting at the right side of the coolant manifold, connect one end of the 3/4" coolant hose to the manifold with a #10 clamp.





136. Route the hose to the top barb (inlet) on the reservoir. Secure the hose with a #10 clamp. Ensure that there are no kinks in any of the hose to restrict coolant flow.



137. Connect the short end of the 90 degree “Elbow” hose to the pump inlet and the long end to the bottom (outlet) barb of the reservoir. Secure both ends with #10 clamps. Connect the remaining length of hose to the outlet barb of the pump and route it through the opening that was uncovered when you removed the molded foam block.



138. Route the hose to the bottom barb (inlet) on the heat exchanger. Cut the hose to length and secure both ends with a #10 clamp. Connect the remaining end of the hose to the upper barb of the heat exchanger and then back through the opening.



139. Route the hose up from the lower opening and across the back side of the air filter cover to the remaining barb on the coolant manifold. Cut the inter-cooler hose to length and secure both ends with a #10 clamp. Note: The rotation of the MAF and the location of the MAF electrical connection.



140. Route the 1/4" hose from the coolant reservoir to the barb on the steam pipe. Cut the hose to length and secure this end with the new #6 clamp supplied.



141. Install alternator on the stock bracket and torque the fasteners to 40 ft-lb.



142. Re-attach the battery cable to the alternator terminal.



143. Use a 15mm tensioner wrench to compress the tensioner and then install the new drive belt using the diagram shown.

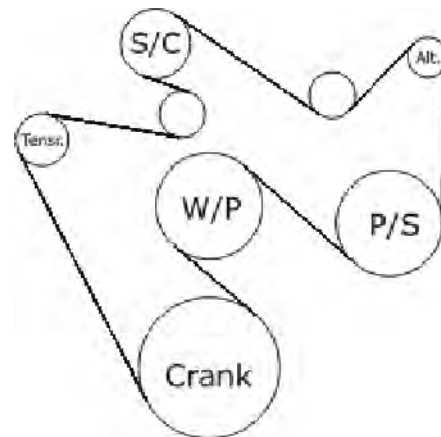



144. With the drive belt installed, rotate the water pump outlet and upper radiator hose out of the way of the supercharger drive pulley. Lock the water outlet into position by tightening the outlet retainer bolt securely with a 12mm wrench.



145. Locate the GM factory-warning and belt routing diagram stickers on the radiator apron. Install the RADIX SSR Vacuum Routing Diagram over the GM vacuum diagram portion of the sticker. Install the Radix Intercooler/belt routing information sticker completely over the original GM belt routing diagram.



The following steps describe modifications to the wiring harness necessary to install the supercharger. Additional diagrams are located in the back of this instruction manual showing these modifications.

146. Remove the wiring harness mounting bracket from the harness.



147. Locate the MAF connector on the wiring harness. The MAF connector is located at the front of the passenger side (right) branch that supplies the fuel injectors and ETC and AC.



148. Remove the black tape and split loom from the MAF connector and wires. Pull the connector and wires back the point where the coil pack connector branch is located.



149. Locate the Tan and the Black wires that are next to each other on the connector, these are the Intake Air Temperature (IAT) circuit. Approximately 1" back from the MAF connector cut these wires.

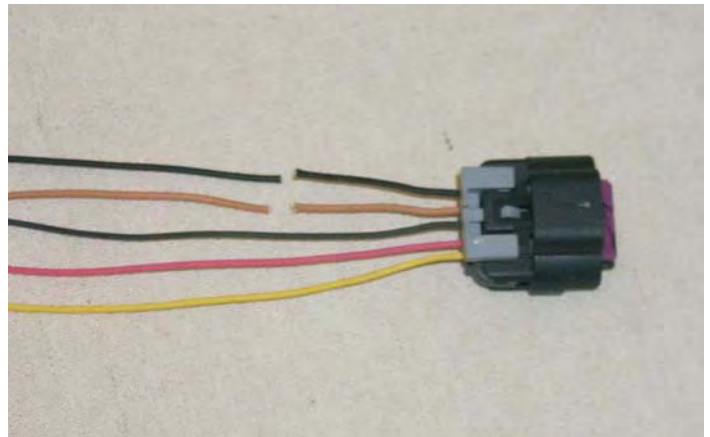

150. Using the new IAT harness and crimp/shrink connectors supplied, connect either white wire of the new harness to the tan wire and the black wire that run to the vehicles computer. The wires to the MAF connector will no longer be used. Strip about ¼" of insulation from the ends of the black and tan wires to the computer and the IAT harness, then crimp the connectors on. Using a heat gun or blow dryer set on HIGH; shrink the insulation on the connectors so that it contracts around the wires completely. You must shrink the insulation, as crimping the connectors alone is not enough to secure them!

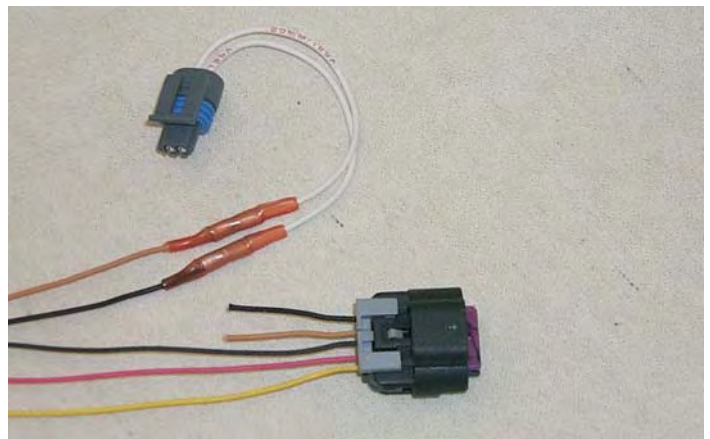

151. Continue to remove the black tape and split loom from the main branch of the harness to the point where the remaining MAF connector and wires emerge from the harness at the point just above the branch for the drivers side injectors.

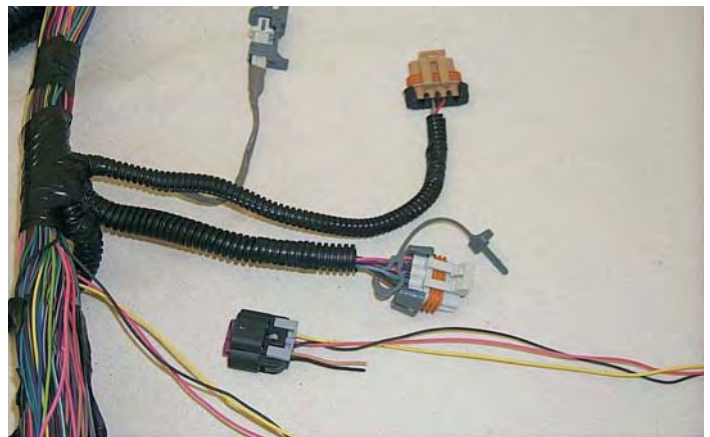



152. Cover the remaining MAF wires with the 1/4" split loom and tape to the point where the MAF wires meet the main branch of the harness.



153. Locate the MAP connector on the harness. Remove the black tape and split loom from the MAP connector and wires. Viewing the connector from the top or clip side note the location and colors of the three wires on the connector, Orange/black left, Green center and Gray on the right. Approximately 1" behind the connector cut these three wires.

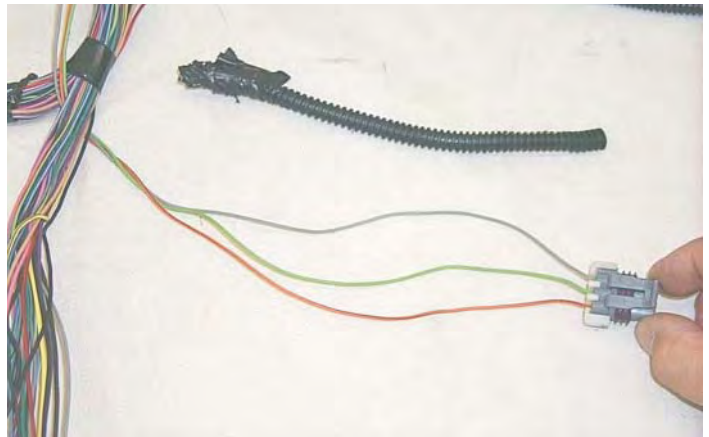

154. Install the new MAP harness to the Orange/black, Green and Gray wires using the crimp/shrink connectors supplied. The new harness wires are all white, so care must be taken so the new white wires are in the same positions as the colored wires on the original connector. Strip about 1/4" of insulation from the ends of all the wires. Crimp the connectors on and shrink the insulation so that it contracts around the wires completely.

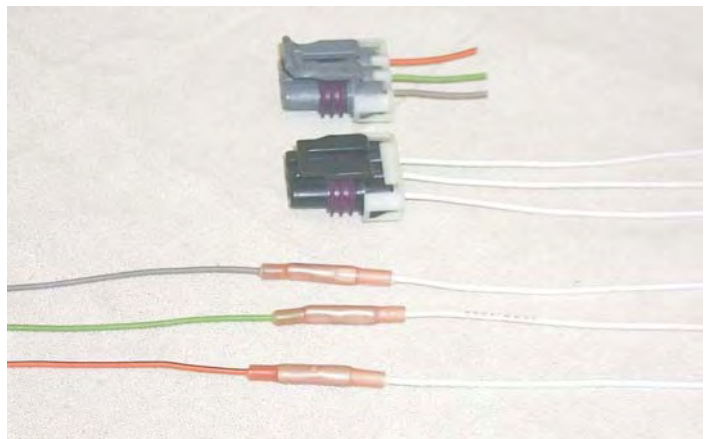

155. Group the IAT branch and MAP branches together and route them along the main branch to the #6 and #8 injector branch. Continue the IAT and MAP branches into the split loom of the right rear injector branch so that they exit the loom after the #8 injector connector. Cover the new branches with split loom and tape.

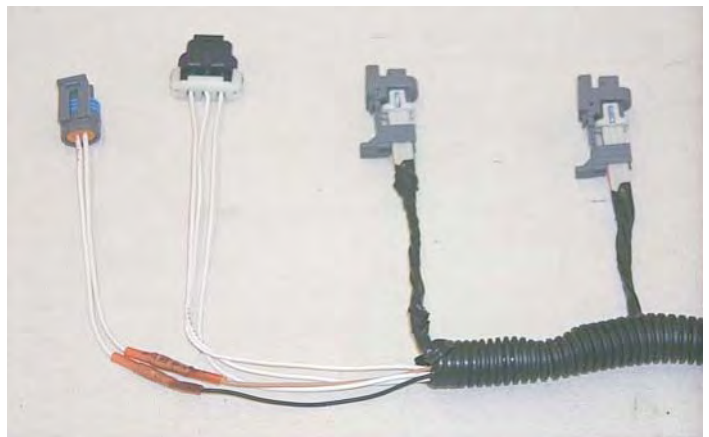

156. Locate the Purge solenoid connector branch on the main branch of the harness.

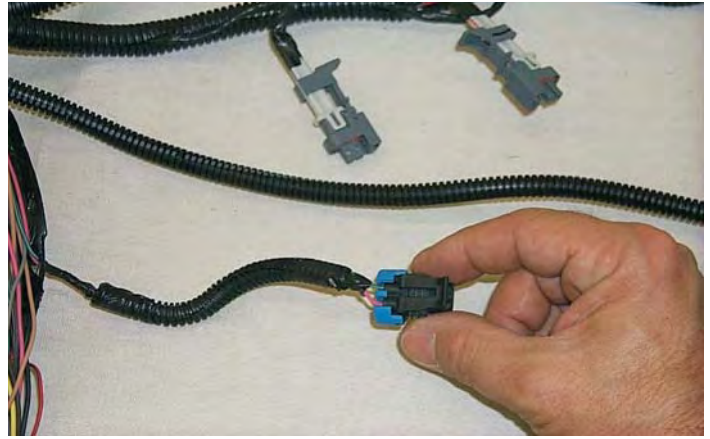

157. Remove the split loom and tape from the wires and pull the connector and wires back the point where the drivers coil pack branch is located. Cover the Purge branch with the new 1/4" loom supplied.



158. Remove about 5" of the large 1-1/4" split loom from the main trunk of the harness. Cover the exposed portions of the main harness with the new 3/4" loom starting from the left side injector branches to the right side coil branch. Tape and secure the new branches as necessary.



159. Re-secure the harness to the mounting clamp near the drivers side coil pack.





160. Pass the main branch of the harness over the left fuel rail and then under the inlet manifold, and drive shaft. Remove the three bolts that secure the fuel rail on the right (passenger) side to the supercharger manifold with a 10mm socket wrench. Pull up on the fuel rail to allow the harness to pass under. Position the harness between the #4 injector and the center fuel rail attachment point. Check that the injectors are still located in their bores and re-tighten the three fuel rail bolts to 96 lb-in.

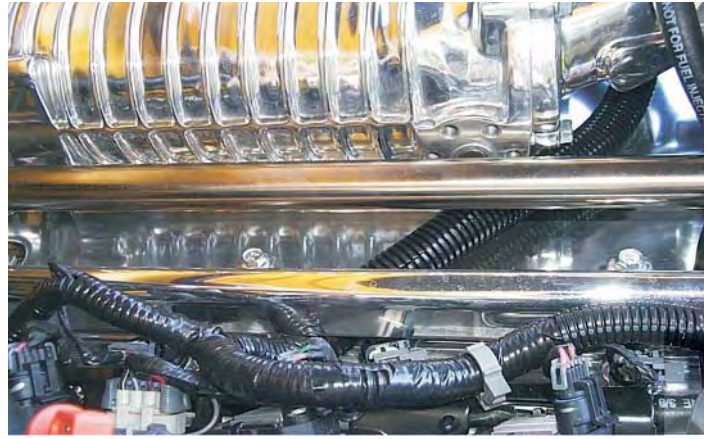

161. On the passenger of the engine, plug in the ETC, A/C, Coil pack and Injector #2, #4, #6, #8 connectors.



162. At the rear of the supercharger on the passenger side, plug in the new MAP and IAT connections.



163. On the driver side of the engine, plug in the Alternator, Injector #1, Coil pack, injector #3, #5, #7, and EVAP connectors.



164. Route the new MAF branch forward to MAF and plug in the connector. Secure the branch as necessary with the tie straps supplied to keep it away from the belt and moving parts.



165. Here is the Intercooler Relay wiring and the Magnavolt module with its components.



166. Locate the relay mounting stud on the driver side next to the windshield washer reservoir. Remove the nut with a 10mm socket wrench. Place the BLACK wires with the ring connectors from both the relay and the Magnavolt harness on the stud and then place the intercooler relay on the stud and secure it with the nut.

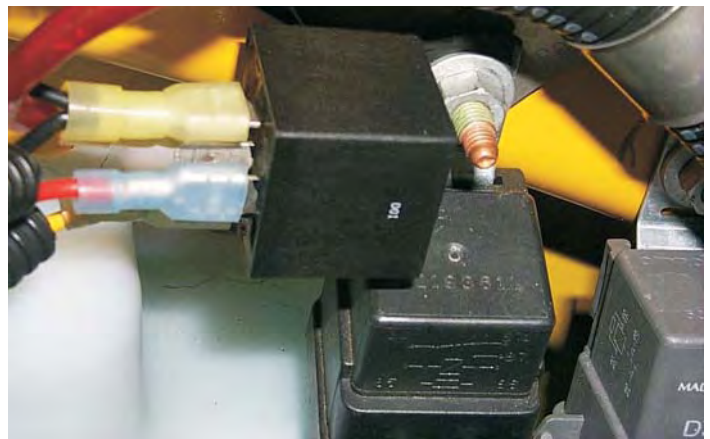

167. Route the intercooler harness and connector across the front of the engine by tie strapping it to the intercooler hose behind the air box. Plug the harness connector into the end of the intercooler pump.





168. Lift the cover off the FUSE/RELAY CENTER and set aside for re-installation.



169. Remove the inner cover.



170. Lift the body of the FUSE /RELAY CENTER up off its base by unfastening the five snaps located along its bottom edge where it meets the base.



171. Unscrew the harness connector anchor bolt on the Fuse/Relay Center with a 7mm socket wrench. The bolt will become loose in the hole but cannot be removed.



172. Remove the small positive battery cable from the bottom of the Fuse/Relay Center by un-clipping its connector with a small straight blade screwdriver.

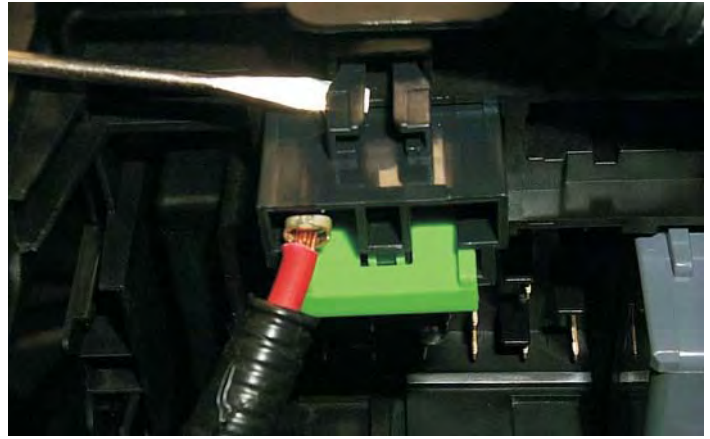

173. Unscrewing the harness connector anchor bolt will allow the large white plug to be removed from the bottom of the Fuse/Relay Center. Locate the GREY wire in the bundle and cut it approximately 1-1/2" from the connector.



174. Install a crimp/shrink connector by cutting the grey wire and stripping a 1/4" of insulation off each end. Into one end of the connector, insert the end of the GREY wire from the large white plug. Into the remaining end insert the end of the YELLOW wire from the intercooler relay and the YELLOW wire from the Magnavolt harness and crimp it securely.



175. Using a heat gun or a blow-dryer set on high, shrink the plastic covering of the connector until the clear sealant from the inside of the connector can be seen oozing out from under the plastic covering. Crimping the connector alone is not enough to insure a permanent connection; you must shrink the plastic covering!





176. Connect the GREY wire from the Magnavolt harness to the remaining end of the Grey wire in the wiring harness with a Blue crimp/shrink connector.

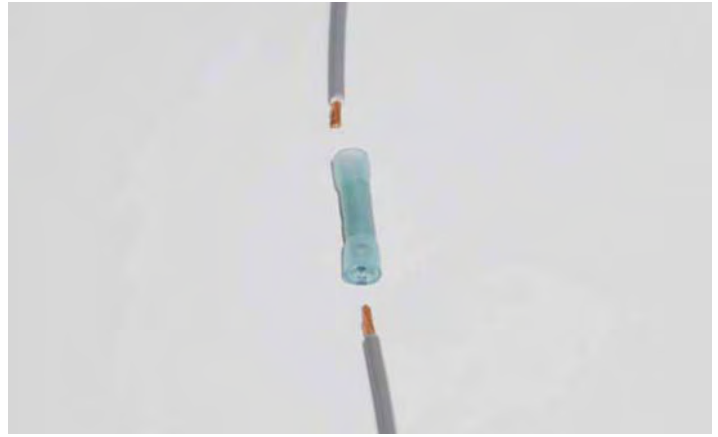

177. Locate the large wiring harness connector on the driver side of the engine compartment next to the brake master cylinder reservoir. Push the grey release handle up to free the male end of the connector.



178. On the male end of the connection, locate the SOLID WHITE wire. This is the Engine Speed Signal (RPM) wire.

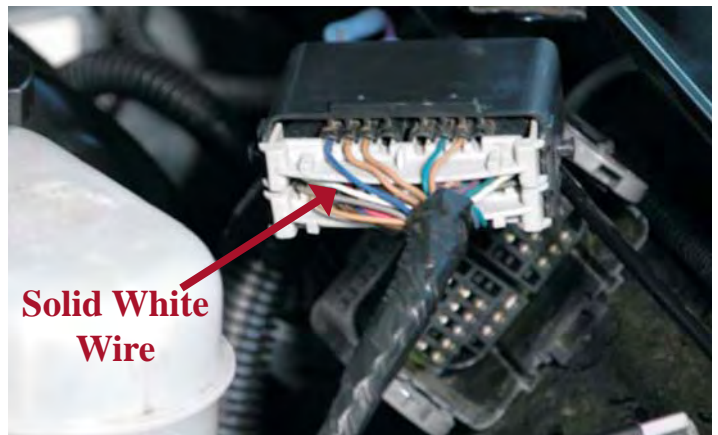

179. Remove the tape a few inches down the harness from the connector and pull the solid white wire away from the rest of the harness. Approximately 1-1/2" from the connector cut the white wire and strip the insulation back 1/4" from the ends. Using a pink crimp/shrink connector supplied re-connect the ends of the white wire adding the WHITE wire from the Magnavolt harness as well to the connection. Cover the wires and the Magnavolt harness with the black split-loom supplied. Re-connect the large harness connector and lock it in place by pushing the grey release handle down.



180. Re-install the harness connector into the body of the Fuse/Relay Center and secure it with the anchor bolt. Snap the small battery cable back into its original location and replace the F/S Center body back on the base.



181. Remove the bolt that secures the large RED battery cable to the terminal at the Fuse/Relay center with a 7mm socket wrench. Attach the RED fused power supply wires of the relay and Magnavolt harness by passing the bolt through the ring connectors. Tighten the bolt securely.



182. Start the Magnavolt installation by removing the cover to the Fuse/Relay Center. Using the Magnavolt unit as a template, mark and drill four 5/16" holes in the top of the cover.



183. Using a 10mm socket wrench, attach the Magnavolt module to the top of the Fuse/Relay Center cover with the nuts and bolts supplied. Replace the inner and top covers on the FUSE/RELAY center.





184. Insert the Magnavolt harness connector into the module until it locks into place.

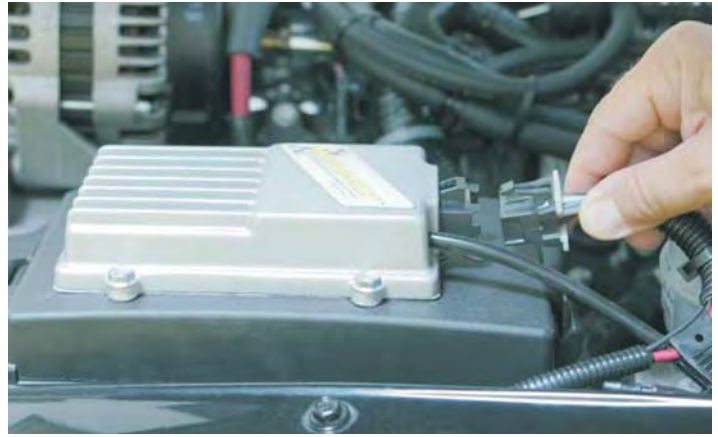

185. On the driver (left) side rear of the supercharger manifold, locate the pressure port capped with a small, rubber cap and remove the cap.



186. Using the hose supplied, connect one end of the hose to the pressure port and then route the other end to the Magnavolt module. Secure the hose out of the way of the rotating parts at the rear of the blower with the Ty-wraps supplied.



187. Connect the remaining end of the hose to the hose on the Magnavolt module using the hose connector supplied. Secure the hose out of the way with the Ty-wraps supplied.



188. Replace the re-programmed computer by snapping back in place on the mounting bracket. Re-install the three connectors by pushing up on the latches and securing them with the Red lock keys. Bolt the mounting bracket back into place with the two mounting bolts. Replace the computer cover and secure it with the two push rivets.



189. Remove the tape from the battery negative (-) cable and re-install it on to the battery with a 8mm wrench.



190. Replace the battery access panel and bolts. Secure them with a 10mm socket wrench.



191. Refill radiator and then fill the intercooler system with a 50/50 mixture of coolant and water. Check system periodically for fluid level.





192. Start the vehicle for 5 seconds and shut off, once again check for fuel leaks and fan-supercharger belt alignment. Check radiator and intercooler reservoir.

193. Test drive vehicle for the first few miles under normal driving conditions, listen for any noises, vibrations, engine missfire or anything that does not seem normal. The supercharger does have a slight whining noise under boost conditions, which is normal. Check & bleed intercooler reservoir as needed.

194. After the initial test drive gradually work the vehicle to wide open throttle runs, listen for any engine detonation (Pinging). If engine detonation is present let up on the throttle immediately. Most detonation causes are low octane gasoline still in the tank.

If you have questions about your vehicles performance, please check with your installation facility or call Magna Charger at (805) 289-0044, Monday through Friday, 8am to 4:30pm.

---

Ventura, CA. Magna Charger, manufacturer of superchargers and supercharger systems for foreign and domestic vehicles, was presented the prestigious award at the annual Specialty Equipment Market Association Show (SEMA) in Las Vegas, Nevada.

Sponsored by General Motors Corporation, the SEMA Design Award for the “Most Innovative Product” was awarded to Magna Charger and recognized by the all-star team of judges for their outstanding and innovative design achievement. The criteria used by the judges included innovation, technical achievement, quality and workmanship.

The award was presented for the Radix® Intercooled supercharger system, designed for the Chevrolet, GMC and Cadillac, 4.8L, 5.3L and 6.0L General Motors Trucks and SUV’s including the new H2 and SSR.



Please enjoy your “Magna Charged” performance responsibly.

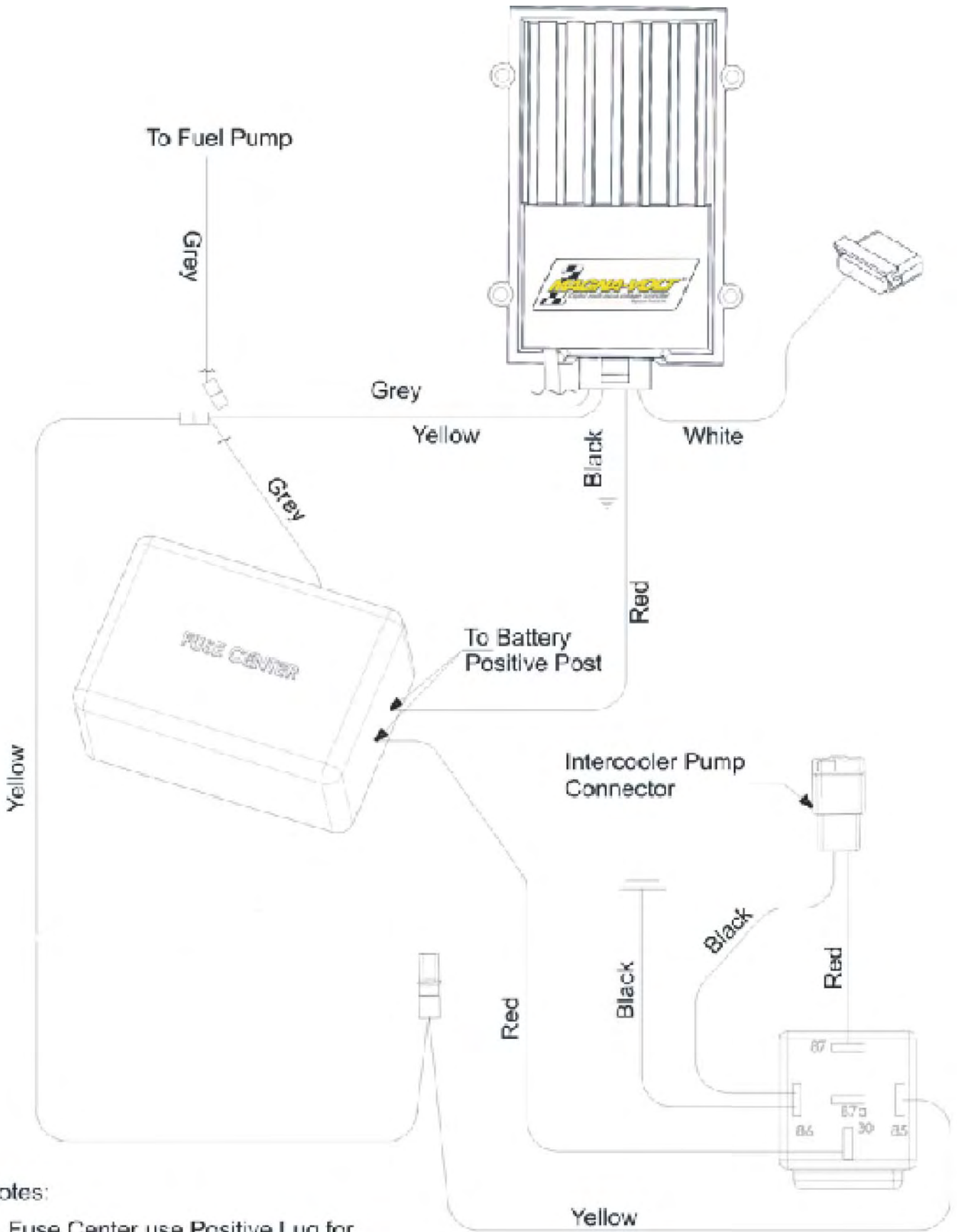

- Notes:
1. Fuse Center use Positive Lug for RED Positive Wire's.

## INTERCOOLER/MAGNAVOLT WIRE ROUTING DIAGRAM



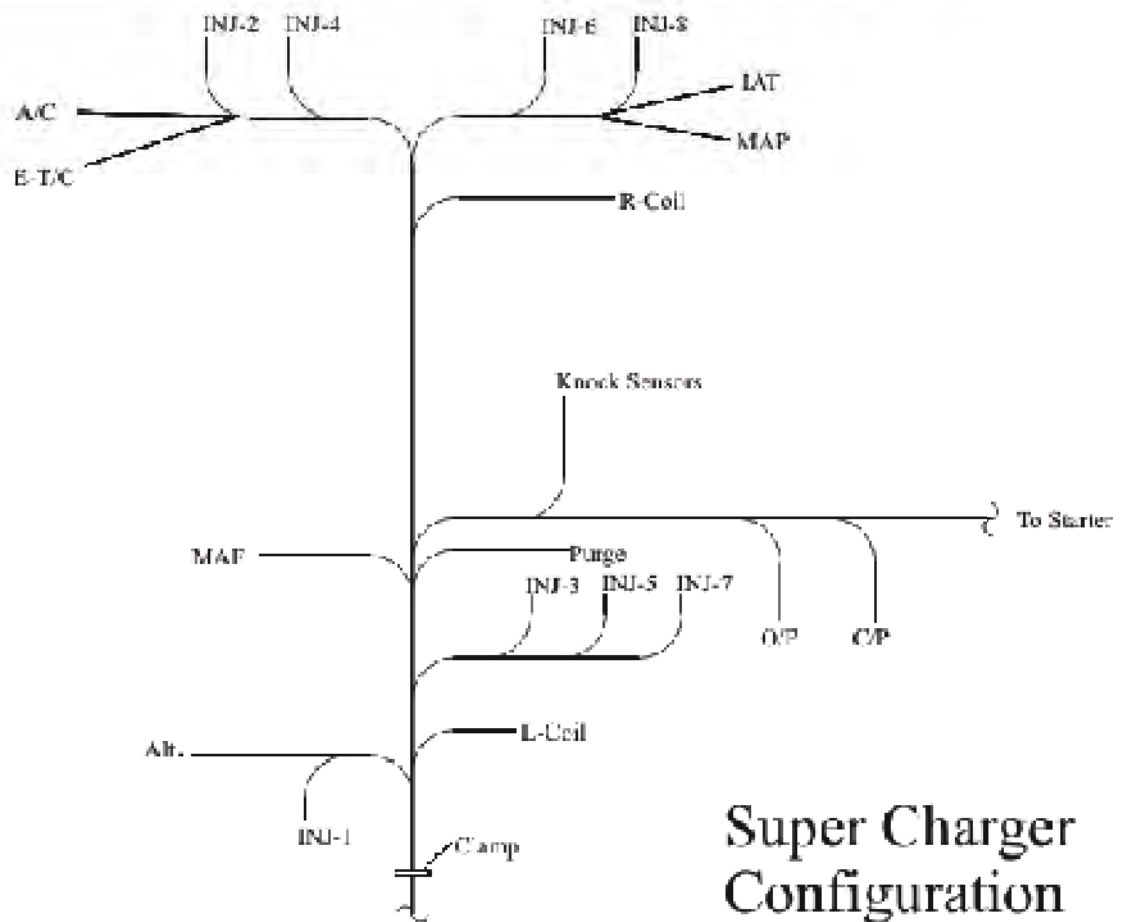
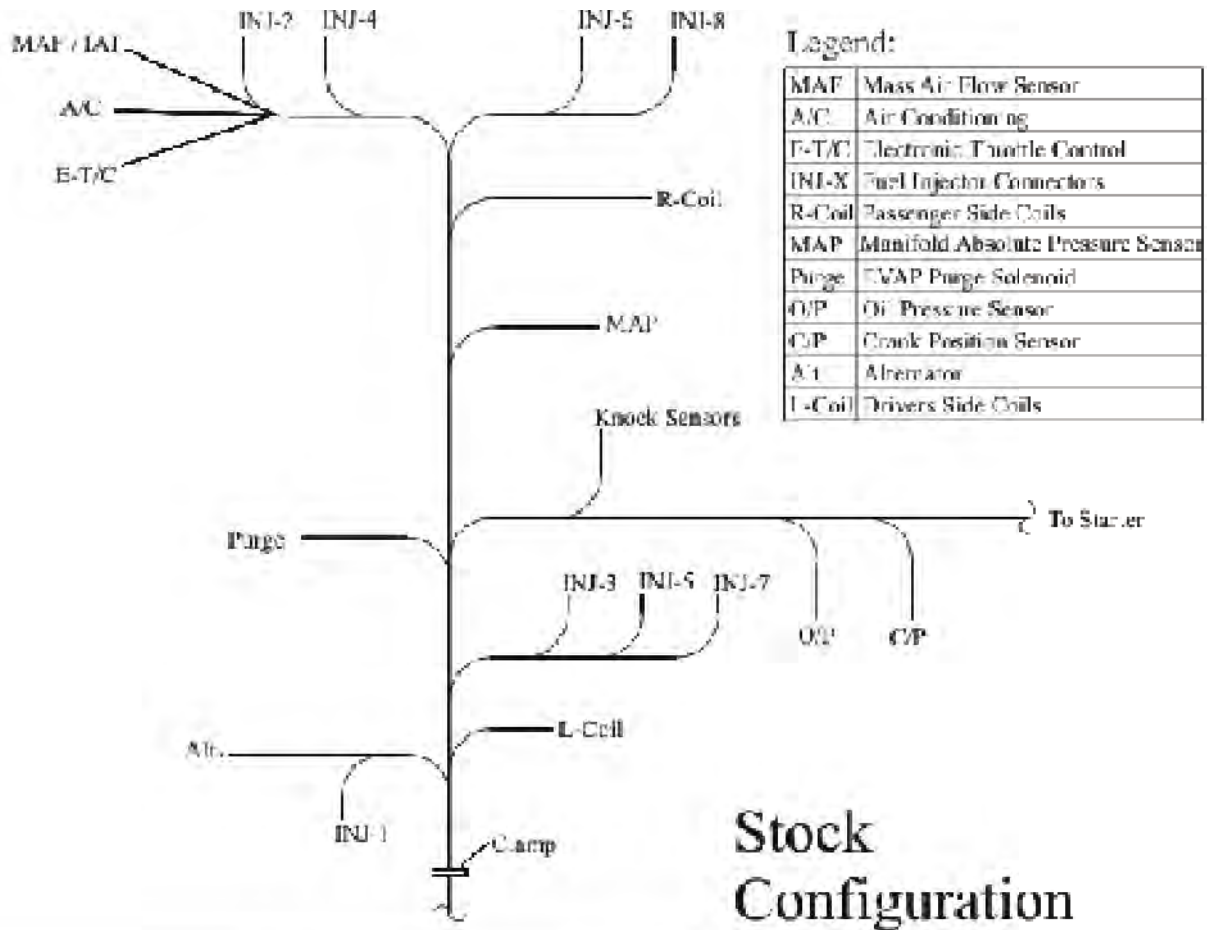

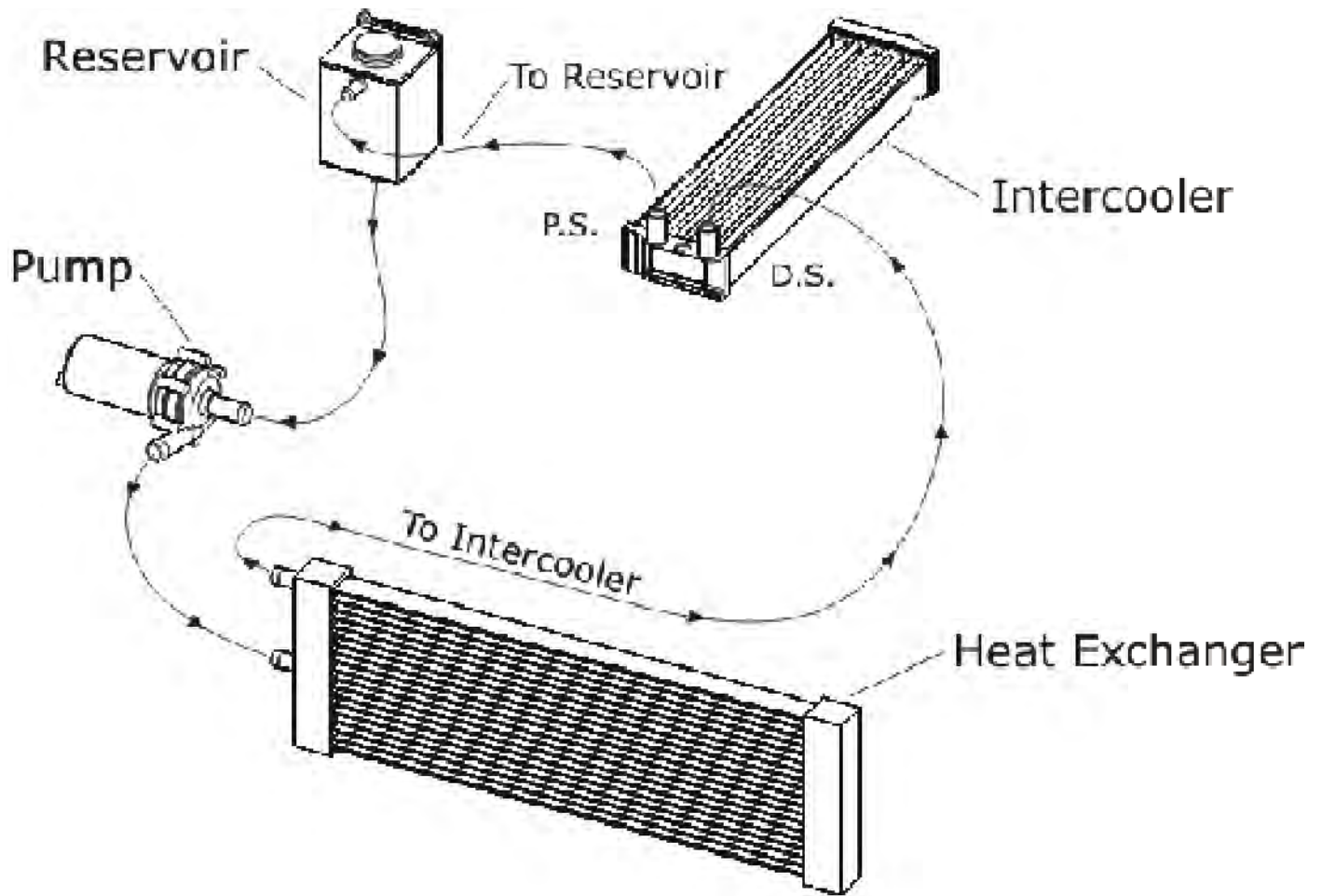

Intercooler plumbing diagram