



**NONRESIDENT
TRAINING
COURSE**



Interior Communications Electrician, Volume 3

NAVEDTRA 14122

IMPORTANT

Any future change to this course can be found at
<https://www.advancement.cnet.navy.mil>, under Products.

You should routinely check this web site.

PREFACE

About this course:

This is a self-study course. By studying this course, you can improve your professional/military knowledge, as well as prepare for the Navywide advancement-in-rate examination. It contains subject matter about day-to-day occupational knowledge and skill requirements and includes text, tables, and illustrations to help you understand the information. An additional important feature of this course is its reference to useful information in other publications. The well-prepared Sailor will take the time to look up the additional information.

Training series information:

This is Volume 3 of a series. For a listing and description of the entire series, see NAVEDTRA 12061, *Catalog of Nonresident Training Courses*, at <https://www.advancement.cnet.navy.mil>.

History of the course:

- *May 1992: Original edition released. Authored by ICCS Bert A. Parker.*
- *Oct 2003: Administrative update released. Technical content was reviewed by ICC(SW) Curtis Fox. No change in technical content.*

Published by
NAVAL EDUCATION AND TRAINING
PROFESSIONAL DEVELOPMENT
AND TECHNOLOGY CENTER
<https://www.cnet.navy.mil/netpdtc>

POINTS OF CONTACT	ADDRESS
<ul style="list-style-type: none">• E-mail: fleetservices@cnet.navy.mil• Phone: Toll free: (877) 264-8583 Comm: (850) 452-1511/1181/1859 DSN: 922-1511/1181/1859 FAX: (850) 452-1370	COMMANDING OFFICER NETPDTC N331 6490 SAUFLEY FIELD ROAD PENSACOLA FL 32559-5000
Technical content assistance. Contact a Subject Matter Expert at https://www.advancement.cnet.navy.mil/welcome.asp , under Exam Info, Contact Your Exam Writer.	

NAVSUP Logistics Tracking Number
0504-LP-026-7840

TABLE OF CONTENTS

CHAPTER	PAGE
1. Technical Administration.....	1-1
2. Quality Assurance	2-1
3. Ship's Drawings and Diagrams	3-1
4. Maintenance	4-1
APPENDIX	
I. Glossary	AI-1
II. References used to develop this NRTC	AII-1
INDEX	INDEX-1

ASSIGNMENT QUESTIONS follow Index.

CHAPTER 1

TECHNICAL ADMINISTRATION

LEARNING OBJECTIVES

Upon completion of this chapter, you will be able to do the following:

1. Identify the steps in planning and scheduling work and in assigning tasks and duties.
 2. Describe the steps in preparing and reviewing casualty reports (CASREPs), casualty corrections (CASCORs), and situation reports (SITREPs).
-

INTRODUCTION

As an IC Electrician First Class or Chief, you can expect to spend much more time on administrative and supervisory duties. As an administrator, you will assign tasks and fill out required reports and schedules. As a supervisor, you will oversee the work and make sure it is done correctly and on time.

As an IC1 or ICC, you maybe required to organize and supervise an IC shop aboard ship. This chapter will give you insight into the areas of shop supervision and report preparation and will provide you with useful tools that will help you fulfill your role as a shop supervisor. Some areas of shop supervision are not covered in this chapter. But, you may find information about these areas in other publications, such as the *Ship's Maintenance and Material Management (3-M) Manual*, OPNAVINST 4790.4B; *Navy Occupational Safety and Health (NAVOSH) Program Manual*, OPNAVINST 5100.23B; *Navy Safety Precautions for Forces Afloat*, OPNAVINST 5100.19B; and *Engineering Administration*, NAVEDTRA 10858-F.

SHOP SUPERVISION

As an ICI or ICC, one of your more important roles will be as a supervisor or leader. You will be responsible for planning and organizing work and supervising and directing personnel.

As the IC1 or ICC in charge of an IC shop, you should fully appreciate and understand the responsibility you hold as a member of a shipboard organization and be able to identify each of your duties with respect to any assigned job.

The following list includes the duties and responsibilities that are common to most shop supervisors:

- Getting the right person on the job at the right time
- Using tools and materials as economically as possible
- Preventing conditions that might cause accidents
- Maintaining discipline
- Keeping records and preparing reports
- Maintaining the quality and quantity of repair work
- Planning and scheduling repair work
- Training personnel
- Requisitioning tools, equipment, and materials
- Inspecting and maintaining tools and equipment
- Giving orders and directions
- Cooperating with others
- Checking and inspecting completed repairs
- Promoting teamwork

MAINTENANCE AND REPAIR

To fulfill your administrative and supervisory responsibilities in connection with maintenance and repair, you must have the ability to plan. By following prescribed procedures of the 3-M Systems, maintenance

planning should be easy. But some administrative and supervisory duties will not be affected by the 3-M Systems. You will always find some engine-room maintenance and repair work that just won't fit into a schedule, but must be done whenever the opportunity arise. So, in addition to having the ability to plan, you must also have a certain amount of flexibility so you can alter your plans to fit the existing circumstances. A few administrative and supervisory considerations that apply to maintenance and repair are discussed in the following sections.

The 3-M Systems, like any other system or program, is only as good as the personnel who make it work. Your role in the 3-M Systems, as an IC1 or ICC, will include the training of lower-rated personnel in its use. These personnel must be trained in the scheduling and supervision of maintenance. As a supervisor, you should keep abreast of all developments and changes to the 3-M Systems. Details on the 3-M Systems and changes related to it are available in the *Ship's Maintenance and Material Management (3-M) Manual*, OPNAVINST 4790.4B.

PLANNING

Careful planning is necessary to keep an IC shop running efficiently and productively. Planning results in the proper employment of your people. Today's IC Electricians are well-trained technicians, who have the right to expect their service to be employed in an orderly fashion with proper organization and supervision.

The weekly PMS work schedule is a proven method of ensuring proper personnel employment. The mechanics of the PMS system allows the supervisor to ensure that there is adequate time for training, ship's evolutions, recreation, and so on. Most important in using PMS is the supervisor's familiarity with the ship's schedule on a given day. You must "get the word" so that you can plan your people's work. Therefore, getting the word is your responsibility. The proper use of the weekly PMS work schedule will, in a short time, result in more training and less equipment downtime. Your subgroup leaders must use foresight in planning this schedule. In particular, avoid stretching your supervisory personnel too thin. A person cannot provide adequate supervision to the installation of an electromagnetic log (sword) and the removal of a wind indicator (bird) at the same time.

The job cards used in the PMS system can be useful maintenance aids on any ship, provided they first are tailored to your ship via the PMS feedback report. Your particular salinity system may have one or two peculiar

steps that must be taken in removing a cell. The cards are made out for a standard system, and modification is possible. Job cards do, however, give properly sequenced procedures for job performance and should be followed

Emergency planning should be done when possible in a checkoff list fashion. By analyzing your needs and, where possible, writing the job out in procedural steps, you may learn many things. On jobs that affect the ship's maneuverability, the written procedural method is particularly effective in getting the right conditions set up and help lined up. By going over the replacement of a synchro transmitter in the propeller revolution indicator circuit step by step with your division officer, you may find that you can have the shaft stopped, thus aiding in the repair of the synchro transmitter.

You must ensure that all personnel are informed about the nature and scheduling of repairs. The realignment of a gyrocompass synchro amplifier may cause havoc for the ETs, FTs, STs, and OSs. However, if you inform the group supervisors ahead of time, they can act to prevent or lessen trouble in their equipment. Emergency repairs require the permission of the OOD. Your division officer should always be notified. You must remember that the IC group is not an end unto itself, but rather a member of a team.

An important phase of planning your work is the organizing of your personnel to accomplish their task. This is, however, a ship-to-ship problem, with subgroup supervisors varying in technical background and subordinate personnel varying in number.

It is imperative that a team spirit is developed in your personnel and that you maintain something of a competitive spirit. Through proper employment of competition, the standard of the IC group at work, at quarters, and in the compartment can be maintained above that of the other engineers. By the nature of the work involved, IC Electricians should be able to maintain their berthing spaces and their uniforms in top condition.

There is often a reluctance on the part of many technicians to make the change to technical supervisor. As the leading IC Electrician, you must ensure that this change takes place. You can do this by assigning part of the supervisory load to personnel who have advanced in an orderly fashion. Take care to provide up-to-date records that will help them on the new assignment. Be sure that time is allowed for them to become familiar with their new responsibility. Take them into your

confidence regarding planning and professional matters.

You, as a supervisor, must be available to your subgroup supervisors, and they, in turn, must be available to their subordinates. Ensure that all requests come up the line in proper fashion. Also, make sure that they go down the line in the same fashion. Avoid collecting request chits at quarters before your petty officers have a chance to consider them. Don't let your personnel get their replies in the log room. Pick them up yourself and return them to the subgroup supervisor. This is a small item, but it reinforces the chain of command. Except when dealing with a severe personal problem, always ask subgroup supervisors to accompany any of their personnel with whom you must converse, rather than have them go it alone. This should give them confidence in their supervisor and you the benefit of the supervisor's views.

As a supervisor, you must be aware of each job as it is worked by your personnel. Show an active interest in the personnel under you. If you do not periodically check on your subordinates' work, you will soon become aware of problems at a later time. As a supervisor, you must, while keeping your hand on the job, keep it off the screwdriver.

INFORMATION ON INCOMING WORK

Job orders will generally be received in the shop several days in advance. You should start planning as soon as possible to gain an advantage of time. Much of your planning may be done before the work is delivered to the work center.

PRIORITY OF JOBS

In planning and scheduling work you will have to give careful consideration to the priority of each job order. Priorities are generally classified as urgent, routine, and deferred.

The majority of job orders will have the routine priority assigned to them. Routine jobs make up the normal workload of the work center, and they must be carefully planned and scheduled so that the daily organization and production can be maintained at a high standard.

Urgent-priority jobs require immediate planning and scheduling. Lower-priority jobs may have to be set aside so that urgent jobs can be done.

Deferred jobs do not present much of a problem. They are usually accomplished when the workload of the shop is light and there are few jobs to be done.

When determining the priority of a task, you should consider the following information:

- The ship's schedule and the effect the equipment will have on the ability of the ship to perform its mission
- Whether the work requires someone with special qualifications
- Whether or not all the required parts and material are available

The work center supervisor should review the work for the week with the division officer and determine the jobs that need to be accomplished right away (priority 1) and those that can be done at a later date (priority 2). The work that cannot be completed due to the lack of material or trained personnel should then be deferred to request material or outside assistance (priority 3). When work gets sent to an outside activity, you should fill out a Ship's Maintenance Action Form, OPNAV 4790/2K (fig. 1-1). When filling out this form, you should fill out all the proper blocks as completely as possible. Refer to figure 1-1 to determine what blocks you must fill out.

You must provide as much technical documentation as possible. You may have to fill out a Supplemental Form, OPNAV 4790/2L (fig. 1-2), when requirements are not covered by technical documentation.

If you cannot complete a priority 1 task because of ship's schedule or other reasons, you should work on a priority 2 task. In this manner, the shop will be able to accomplish assigned tasks in a timely and effective manner.

SCHEDULING OF WORK

The main object in the scheduling of work is to have the work flow smoothly and without delay, since lost time between jobs lowers the overall efficiency of the work center. Because of the variety of jobs you and your personnel will be required to perform, specific work schedules must be prepared to ensure that all work is completed. Although these schedules list specific job assignments, they must be flexible enough to allow for changes in priorities, transfer of personnel, temporary breakdowns of equipment, unscheduled ship drills, or any emergency that may arise.

You may have to change the schedule of work in the work center when new high-priority jobs come in.

OPNAV 4790/2K (Rev. 8-75) S/N 0107 LF 047 9011	SHIP'S MAINTENANCE ACTION FORM (2-KILO)				<input type="checkbox"/> <input checked="" type="checkbox"/>							
SECTION I. IDENTIFICATION	JOB CONTROL NUMBER											
1. SHIP'S UIC	2. WORK CENTER	3. JOB SEQ. NO.	4. APL/TEL									
Φ 4669	EBΦ 1	Φ 111	Φ 212 Φ Φ 166									
A. SHIP'S NAME	5. EQUIPMENT NESH NAME	6. WNO STA CAS IDN				7.	8.	9.	10.	11.	12.	
USS JOHN KING	BOILER RH											
B. HULL NUMBER	13. IDENT. EQUIPMENT SERIAL NUMBER	14. IIC										
DDG-3	1A	F1Φ 1	1276									
15. SAFETY HAZARD <input checked="" type="checkbox"/>	16. LOCATION (Compartment/Deck/Floor/Side)	17. WHEN DISCOVERED DATE				18.	19.	20.	21.	22.	23.	24.
B1-5-61-Φ	Φ	6 Φ 11										
18. ALTERATIONS (SHIPALT, ORDALT, Fid Tag, etc.)	19. ...	20. INS. NO. NUMBER	21. ...	22. ...	23. ...	24. ...	25. ...	26. ...	27. ...	28. ...	29. ...	30. ...
SECTION II. DEFERPAL ACTION	25. S/F MHRS. EXP.	26. DEFER. DATE	27. S/F MHRS. REM.	28. DEADLINE DATE								
	Φ Φ 2 Φ	6 Φ 1	Φ Φ 17	6 Φ 9 17								
SECTION III. COMPLETED ACTION	29. ACT. TKN	30. S/F MHRS.	31. COMPLETION DATE	32. ACT. MAINT. TIME	33. ...	34. METER READING						
SECTION IV. REMARKS/DESCRIPTION	35. REMARKS/DESCRIPTION											
SAFETY VLV B OPERATING ERRATIC INDICATING A BENT VLV SPINDLE. XXXREMOVE SAFETY VLV DELIVER TO IMA DISASSEMBLE AND INSPECT. IF OUT OF TOLERANCE REPAIR OR REPLACE REASSEMBLE VLV AND TEST. SHIP PICKUP VLV REINSTALL AND TEST. DUE TO INOPERABLE SAFETY VLV BOILER MAY BE OVER PRESSURIZED												
37. SHIP'S SIGNATURE												
SAFETY VLV B SPINDLE BENT												
36. FIRST CONTACT/MAINT. MAN (Print)	38. RATE	40. SECOND CONTACT SUPERVISOR (Print)	41. ...	42. ...	43. INTEGRATED PR. OR. IT.							
J. LINGO	BTC	D. HAMMOND	1	2								
C. DIV. INIT.	D. DEPT. INIT.	E. COMMANDING OFFICER'S SIGNATURE	F. TYCOM AUTHORIZATION	44. ...	45. ...							
D.M.	L.R.	C.C. Parker CDR, USN										
46. SPECIAL PURPOSE												
SECTION V. SUPPLEMENTARY INFORMATION	47. BLUEPRINTS, TECH. MANUALS, PLANS, ETC.											
NS-351-Φ 664	48. PREARRIVAL/ARRIVAL CONFERENCE ACTION/REMARKS											
SECTION VI. REPAIR ACTIVITY PLANNING/ACTION	49. REPAIR W/C											
50. EST. MHRS.	51. ASST. REPAIR W/C	52. ASST. EST. MHRS.	53. SCHED. START DATE	54. SCHED. COMP. DATE								
55. REPAIR ACTIVITY UIC	56. WORK REQ. ROUTINE	57. EST. MANDAYS	58. EST. MANDAY COST \$	59. EST. MATERIAL COSTS \$								
60. EST. TOTAL COST \$	61. JOB ORDER NUMBER	62. LEAD PRE CODE	63. DATE OF EST.									
64. FINAL ACT	65. MHRS. EXPENDED	66. DATE COMPLETED	G. COMPLETED BY (Signature - Rate)	H. ACCEPTED BY (Signature - Rate/Rank)								

Figure 1-1. Ship's Maintenance Action Form (2-KILO).

SECTION I. IDENTIFICATION

A SHIP'S NAME		B HULL NUMBER	JOB CONTROL NUMBER			
			C SHIP'S UIC	D WORK CENTER	E JOB SEQ NO	
		F CONTINUATION FOR		<input type="checkbox"/> ZK	<input type="checkbox"/> ZL	<input type="checkbox"/> ZP

SECTION II. REMARKS/SKETCHES

C

SECTION III. AUTHENTICATION

H FIRST CONTACT/MAINTENANCE MAN (Print)	I DATE		J SECOND CONTACT/SUPERVISOR (Print)	K DATE	
	YR	DAY		YR	DAY

Figure 1-2.-Supplemental Form (2-LIMA).

Sometimes you may have to set other work aside temporarily until these urgent jobs are completed.

Careful planning is required to keep up with all shipboard maintenance and repair work. Some of the factors that you should consider when scheduling maintenance and repair work are as follows:

- Size up each job before you let anyone start working on it. Check the applicable maintenance requirement cards (MRCs) so that you will know exactly what needs to be done. Also, check all applicable drawings and manufacturer's technical manuals.
- Check on materials before you start. Be sure that all required materials are available before your personnel start working on any job. Do not overlook small items, such as nuts, bolts, washers, packing and gasket materials, tools, and measuring devices. A good deal of labor can be saved by the simple process of checking on the availability of materials before a job is actually started. An inoperable piece of equipment can become a nuisance and a safety hazard if it is spread around the room in bits and pieces while you wait for the arrival of repair parts or materials.
- Check on the priority of the job and of all other work that needs to be done before scheduling any job.
- When assigning tasks, carefully consider the capabilities and experience of your personnel. As a rule, the more complicated jobs should be given to the more skilled and more experienced people. When possible, however, less experienced personnel should be given difficult tasks to do under supervision so that they may gain experience in such tasks. Be sure that the person who is going to do a job is given as much information as necessary. An experienced person may need only a drawing and a general statement about the nature of the job. A less experienced person is likely to require additional instructions and, as a rule, closer supervision.

Keep track of the work as it is being done. In particular, check to be sure that the proper materials and parts are being used, that the job is properly laid out or set up, that all tools and equipment are being correctly used, and that all safety precautions are being followed.

After a job has been completed, make a careful inspection to be sure that everything has been done

correctly and that all final details have been taken care of. Check to be sure that all necessary records or reports have been prepared. These job inspections serve at least two very important purposes: first, they are used to make sure that the work has been completed in a satisfactory manner; and second, they provide for an evaluation of the skills and knowledge of the person who has done the work. Do not overlook the training aspects of a job inspection. When your inspection of a completed job reveals any defects or flaws, be sure to explain what is wrong, why it is wrong, and how to avoid similar mistakes in the future.

ESTIMATING WORK

You will often be required to estimate the amount of time, the number of personnel, and the amount of material that is needed for repair work. Actually, you are making some kind of estimate every time you plan and start a job, as you consider such questions as How long will it take? Who can best do the job? How many people will be needed? Are all necessary materials available?

However, there is one important difference between the estimates you make for your own use and those you make when your division officer asks for estimates. When you give an estimate to someone in authority over you, you cannot tell how far up the line this information will go. It is possible that any estimate you give to your division officer could affect the operational schedule of the ship. It is essential, therefore, that such estimates be as accurate as you can possibly make them.

Many of the factors that apply to the scheduling of all maintenance and repair work apply also to estimating the time for a particular repair job. You cannot make a reasonable estimate until you have sized up the job, checked on the availability of skilled personnel and materials, and checked on the priority of the various jobs for which you are responsible. To make an accurate estimate of the time required to complete a specific repair job, you must consider (1) what part of the work must be done by other shops, and (2) what interruptions and delays may occur. Although these factors are also important in the routine scheduling of maintenance and repair work they are also important when you are making estimates of time that may affect the operational schedule of the ship.

If part of the job must be done by other shops, you must consider not only the time actually required by these other shops, but also the time that

may be lost if one of them holds up your work and the time spent to transport material between shops. Each shop should make a separate estimate, and the estimates should be combined to get the final estimate. Do not try to estimate the time that will be required by other personnel. Attempting to estimate what someone else can do is risky because you cannot possibly have enough information to make an accurate estimate.

Consider all the interruptions that will cause delays, over and above the time required for the work itself. Such things as drills, inspections, field days, and working parties have quite an effect on the number of people who will be available to work on the job at any given time.

Estimating the number of personnel required for a certain repair job is, obviously, closely related to estimating time. You will have to consider not only the nature of the job and the number of people available, but also the maximum number of people who can work EFFECTIVELY on a job or on part of the job at the same time. On many jobs there is a natural limit to the number of people who can work effectively at any one time. On a job of this kind, doubling the number of personnel will not cut the time in half; instead, it will merely result in confusion and aimless milling around.

The best way to estimate the time and the number of personnel needed to do a job is to divide the total job into the various phases or steps that will have to be done, and then estimate the time and personnel required for each step, taking in consideration the ship's schedule during each step. One way of getting a handle on what is going on during each step is to consult the ship's master training schedule and the monthly training plan. Taking all this miscellaneous time into consideration will give you an accurate estimate of time required to accomplish the job.

Estimating the materials required for a repair job is often more difficult than estimating the time and labor required for the job. Although your own experience will be your best guide for this kind of estimating, a few general considerations should be noted:

- Keep accurate records of all materials and tools used in any major repair job. These records serve two purposes: first, they provide a means of accounting for materials used; and second, they provide a guide for estimating materials that will be used for similar jobs in the future.
- Before starting any repair job, plan the job carefully and in detail. Make full use of

manufacturers' technical manuals, blueprints, drawings, and any other available information. Try to find out in advance all the tools and materials needed for the job.

- Make a reasonable allowance for waste when calculating the amount of material you will need.

MATERIALS AND REPAIR PARTS

The responsibility for maintaining adequate stocks of engine-room repair parts and repair materials belongs at least as much to you as it does to the supply department. The duties of the supply officer are to buy, receive, stow, issue, and account for most types of stores required for the support of the ship. However, the supply officer is not the prime user of repair parts and repair materials; the initiative for maintaining adequate stocks of repair materials, parts, and equipment must come from the personnel who are going to use such items. Namely you!

Basic information on supply matters is given in *Military Requirements for Petty Officer Third Class*, NAVEDTRA 12044-A.

Identification of repair parts and materials is not usually a great problem when you are dealing with familiar equipment on your own ship. But it may present problems when you are doing repair work for other ships, as you would if assigned to the gyro shop on a repair ship or tender.

The materials and repair parts to be used are specified for many jobs, but not for all. When materials or parts are not identified in the instructions accompanying a job, you will have to use your own judgment or do research to find out what material or part should be used. When you must make the decision yourself, select materials on the basis of the purpose of the parts and the service conditions they must withstand.

Because materials and repair parts are not specified in the instructions accompanying a job does not mean that you are free to use your own judgment in selecting parts and materials to accomplish a job. Instead, you must know where to look for information on the type of material or repair parts needed, then locate and requisition them to complete the assigned job. The shipboard sources of information that will be most helpful to you in identifying or selecting materials are as follows:

- Nameplates on the equipment

- Manufacturers' technical manuals and catalogs
- Stock cards maintained by the supply officer
- Ships' plans, blueprints, and other drawings
- Allowance lists

Nameplates on equipment supply information about characteristics of the equipment. These are a useful source of information about the equipment itself. Nameplate data seldom, if ever, include the exact materials required for repairs. However, the information given on the characteristics of the equipment maybe a useful guide in the selection of materials.

Manufacturers' technical manuals are provided with all machinery and equipment aboard ship. Materials and repair parts are sometimes described in the text of these technical manuals. More commonly, however, details of materials and parts are given on the drawings. Manufacturers' catalogs of repair parts are also furnished with some shipboard equipment. When available, these catalogs are a valuable source of information on repair parts and materials.

The set of stock cards maintained by the supply officer is often a useful source of information on repair materials and repair parts. One of these cards is maintained for each type of machinery repair part carried on board ship.

Ships' plans, blueprints, and other drawings available on board ship are excellent sources of information to use in locating materials and repair parts when making various kinds of repairs. Many of these plans and blueprints are furnished in the regular large sizes; but lately, microfilm is being used increasingly for these drawings. Information obtained from plans, blueprints, and other drawings should always be compared to the information given on the ship's Coordinated Shipboard Allowance List (COSAL) to ensure that any changes made since the original installation have been noted on the drawings.

When you request materials or repair parts, remember to find the correct stock number for each item requested. All materials in the supply system have an assigned stock number. You can locate them by using the COSAL and other sources of information. Furnish enough standard identification information so that supply personnel on board ship or ashore can identify the item you want. Experienced supply personnel are familiar with identification publications. They can help you to locate the correct stock numbers and other important identifying information.

PREPARATION OF REPORTS

Planned maintenance action forms have shown themselves adaptable to naval engineering usage. In addition to these, however, there are several other required reports, such as quarterly reports, casualty reports (CASREPs), casualty corrections (CASCORS), and situation reports (SITREPs). The following paragraphs will discuss these reports.

QUARTERLY REPORTS

Quarterly inspection and reports are required as an entry in the gyrocompass service record. These reports should be completed and submitted to the gyrocompass officer for review. The gyrocompass officer is responsible for the administration and supervision of maintenance and repair of the gyrocompass.

CASUALTY REPORTS

When equipment cannot be repaired within a 24-hour period, you should submit a CASREP. The CASREP has been designed to support the Chief of Naval Operations (CNO) and fleet commanders in the management of assigned forces. The CASREP also alerts the Naval Safety Center of incidents that are crucial in mishap prevention. The effective use and support of U.S. Navy units and organizations require an up-to-date, accurate operational status for each unit. An important part of operational capability is equipment casualty information. When casualties are reported, operational commanders and support personnel are made aware of the status of equipment malfunctions that may result in the degradation of a unit's readiness. The CASREP also reports the unit's need for technical assistance and/or replacement parts to correct the casualty. Once a CASREP is reported, CNO, fleet commanders, and the Ship's Parts Control Center (SPCC) receive a hard copy of the message. Additionally, the CASREP message is automatically entered into the Navy Status of Forces (NSOF) data base at each fleet commander-in-chief's site and corrected messages are sent to the CNO's data base.

As INITIAL, UPDATE, CORRECTION (CORRECT), and CANCELLATION (CANCEL) CASREP messages are submitted, managers are able to monitor the current status of each outstanding casualty. Through the use of high-speed computers, managers are able to collect data concerning the history of malfunctions and effects on readiness. This data is necessary to maintain and support units dispersed throughout the world.

Unit commanders must be aware that alerting seniors to the operational limitations of their units, brought about by equipment casualties, is as important as expediting receipt of replacement parts and obtaining technical assistance. Both of these functions of casualty reporting are needed to provide necessary information needed in the realm of command and control of U.S. Navy forces and to maintain the units in a truly combat-ready status. Support from every level, including intermediate and unit commanders, is essential to maintain the highest level of combat readiness throughout the Navy.

General Rules and Procedures for CASREPs

A casualty is defined as an equipment malfunction or deficiency that cannot be corrected within 48 hours and that fits any of the following categories:

- Reduces the unit's ability to perform a primary mission
- Reduces the unit's ability to perform a secondary mission (casualties affecting secondary mission areas are limited to casualty category 2)
- Reduces a training command's ability to perform its mission or a specific segment of its mission, and cannot be corrected or adequately accommodated locally by rescheduling or double-shifting lessons or classes.

Types of Casualty Reports

The CASREP system contains four different types of reports: INITIAL, UPDATE, CORRECT, and CANCEL. These reports of equipment casualties are submitted using a combination of two or more messages, depending on the situation and contributing factors. The four different types of CASREPs are discussed in the following paragraphs. Additional information concerning CASREPs can be found in NWP 10-1-10.

INITIAL.– The INITIAL CASREP identifies, to an appropriate level of detail, the status of the casualty and parts and/or assistance requirements. This information is needed by operational and staff authorities to set proper priorities for the use of resources.

UPDATE.– The UPDATE CASREP contains information similar to that submitted in the INITIAL CASREP and/or submits changes to previously submitted information.

CORRECT.– A unit submits a CORRECT CASREP when equipment that has been the subject of casualty reporting is repaired and back in operational condition.

CANCEL.– A unit submits a CANCEL CASREP upon commencement of an overhaul or other scheduled availability period when equipment that has been the subject of casualty reporting is scheduled to be repaired. Outstanding casualties that will not be repaired during such availability will not be canceled and will be subject to normal follow-up casualty reporting procedures as specified.

Casualty Categories

A casualty category is associated with each reported equipment casualty. The category reflects the urgency or priority of the casualty. All ships, shore activities, and overseas bases (except NAVEDTRACOM activities) use three casualty categories—2, 3, or 4. NAVEDTRACOM activities use four categories—1, 2, 3, or 4. The casualty category, although not a readiness rating, is directly related to the unit's Status Resource-Specific Categories (this information is explained in NWP 10-1-10, chapters 5 and 6, "Status of Resources and Training System [SORTS])," in those primary and/or secondary missions that are affected by the casualty.

The casualty category is based upon the specific casualty situation being reported and may not necessarily agree with the unit's overall status category. The casualty category is reported in the casualty set and is required in all CASREPs.

The selected casualty category will never be worse than a mission area M-rating reported through SORTS for the primary missions affected by the casualty.

Figure 1-3 shows a decision logic tree that provides a logical approach to assist in determining the casualty category and whether or not a CASREP is required. Figure 1-4 shows a similar decision logic tree for NAVEDTRACOMs.

Message Format

A CASREP message consists of data sets that convey sufficient information to satisfy the requirements of a particular casualty reporting situation. These data sets are preceded by a standard Navy message header consisting of precedence, addressees, and classification. The following message conventions also apply to CASREP messages.

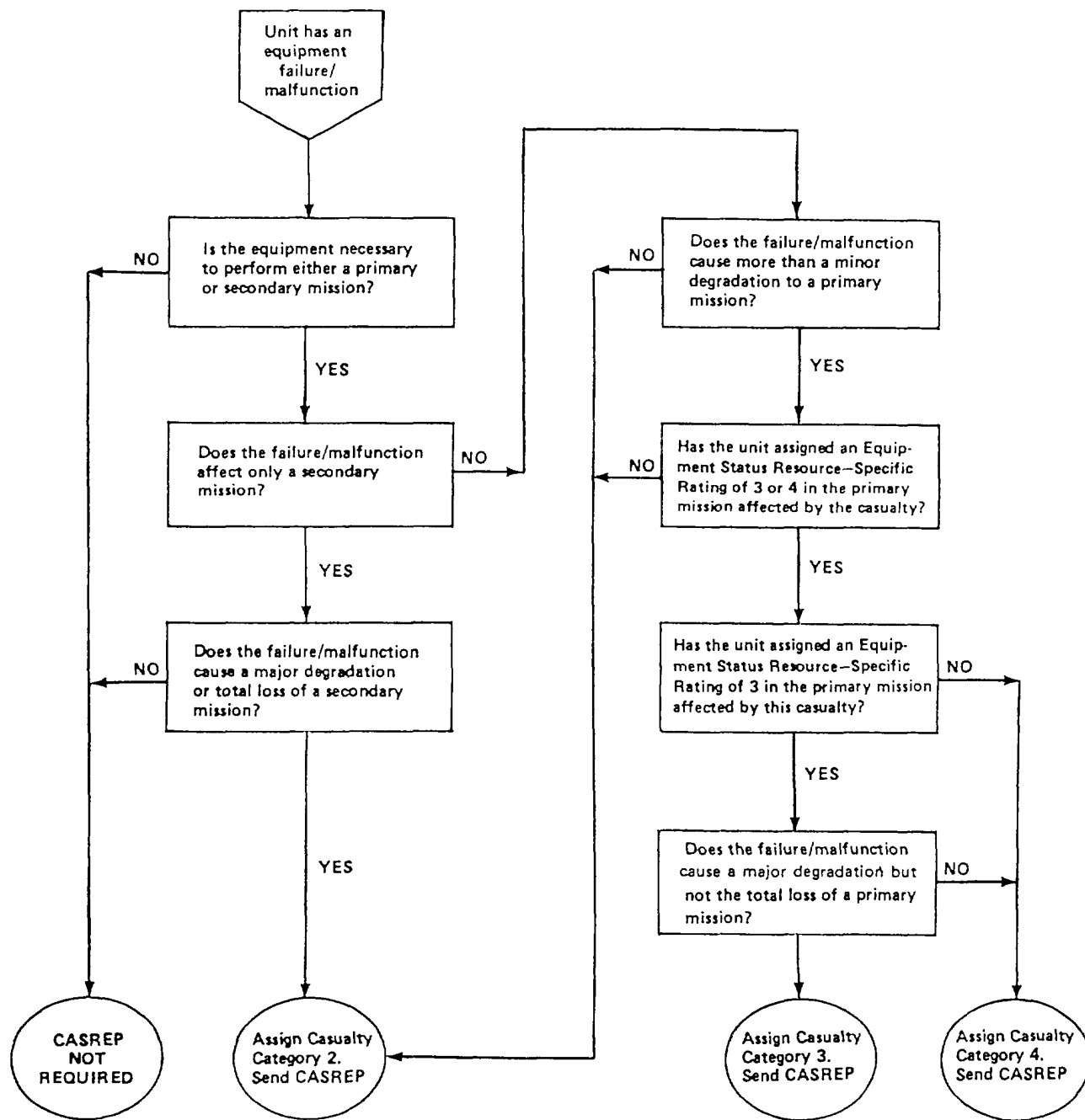


Figure 1-3.-Casualty category decision tree.

MESSAGE SERIALIZATION.— The CASREP message will always be serialized. The serialization will be the MSGID (message identification) set that appears immediately after the message classification line. The serial numbers are sequential from 1 through 999 for all CASREPs originated by a unit. Serial numbers must never be repeated until a new sequence of numbers 1 through 999 has begun. A new sequence of numbers

starts after the unit has submitted CASREP message number 999.

MESSAGE ERRORS.— CASREP messages transmitted with errors, either in format or in content, can only be corrected on a UPDATE CASREP message from the originating command, not by a CORRECT CASREP, a CANCEL CASREP, or a separate message.

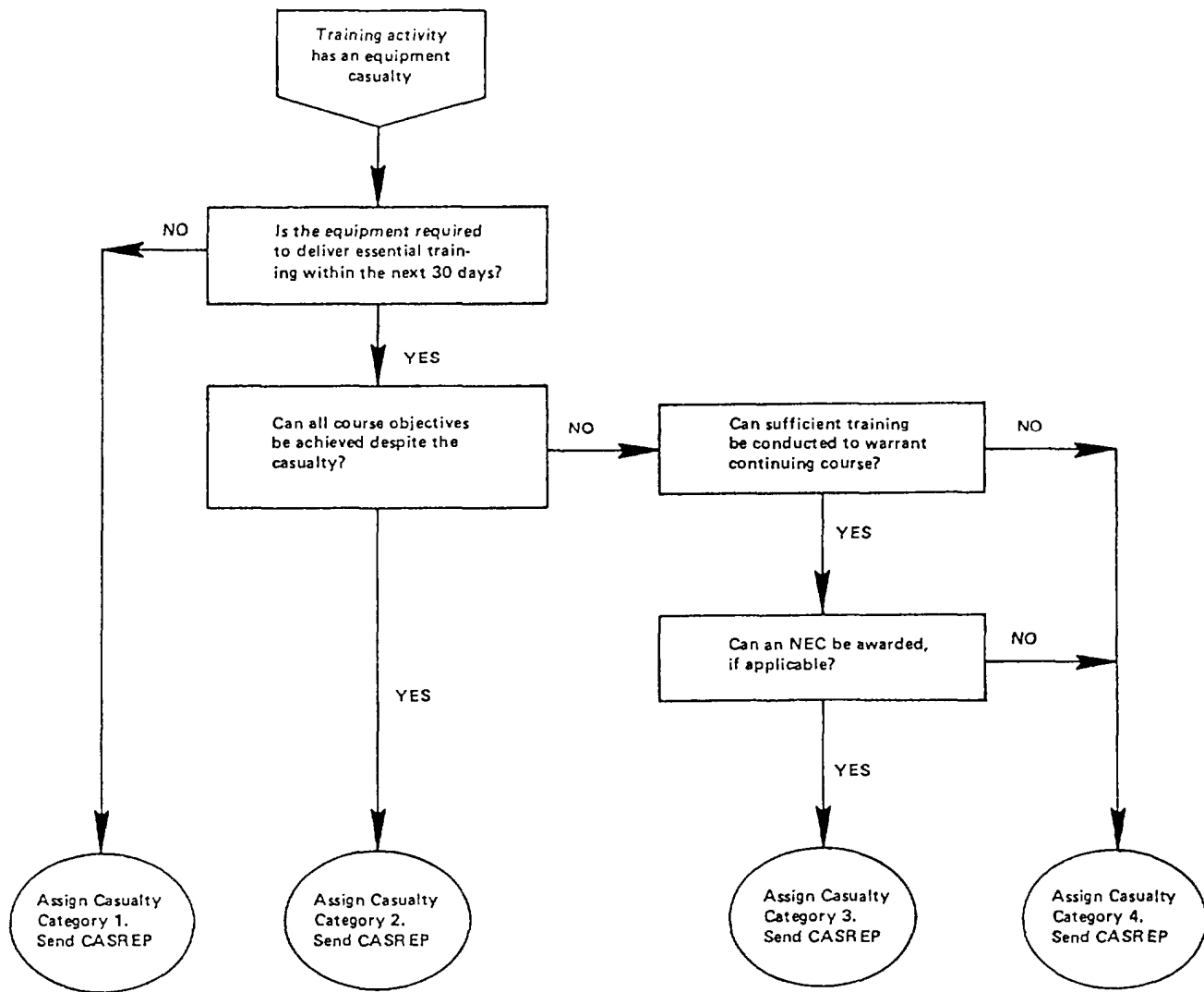


Figure 1-4.-NAVEDTRACOM casualty category decision tree.

MESSAGE TEXT STRUCTURE.— The text of a CASREP message is composed of data sets as necessary to report a particular situation. Each data set, in turn, is composed of one or more data fields. The fields in each set are grouped according to their relationship. The three types of data sets used in CASREP messages are as follows:

- The linear data set, which consists of a set identifier and one or more data fields present in a horizontal arrangement.
- The columnar data set, which is used to display information in tabular form and contains multiple data lines. The first line of the set consists of a set identifier, the second line contains column headers, and subsequent lines contain data fields that are aligned under the appropriate headings.

- The free text set, which consists of a set identifier followed by a single, unformatted, narrative data field. This type of set is used to explain or amplify formatted information contained in one or more of the linear or columnar data sets in a message. Figures 1-5, 1-6, and 1-7 are examples of the data sets.

Reporting Criteria

The following paragraphs will discuss the reporting criteria for each type of CASREP.

INITIAL CASREP.— An INITIAL CASREP (fig. 1-8) is used to report the occurrence of a significant equipment casualty and provides specific information concerning repair of the casualty. Only one initial casualty may be submitted per CASREP message. All required information must be submitted in the INITIAL

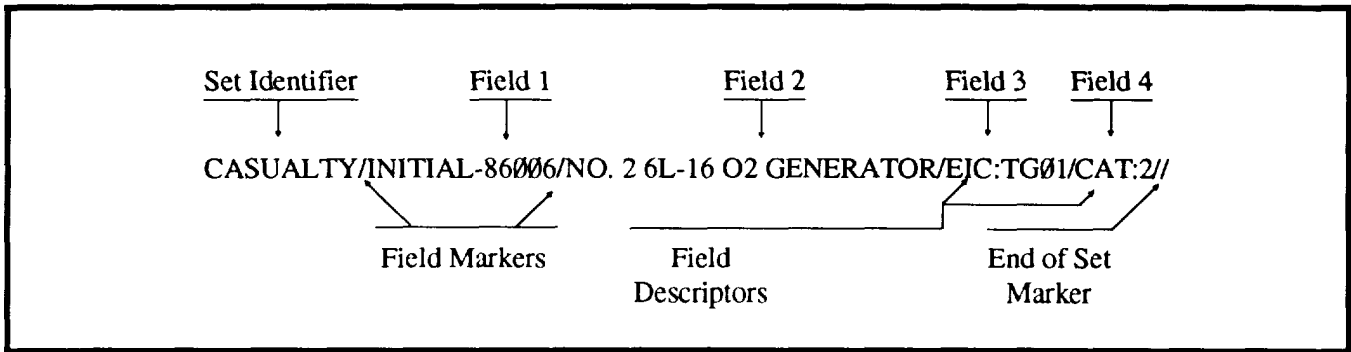


Figure 1-5.-Linear data set.

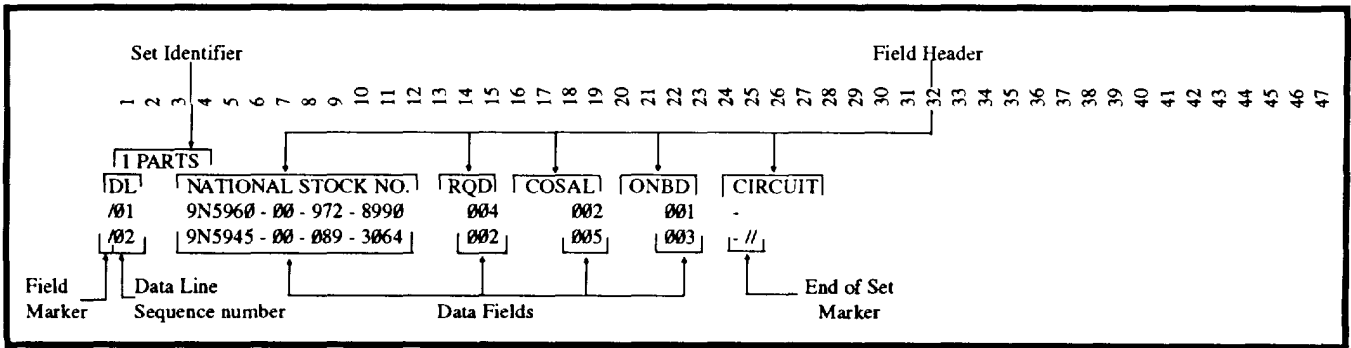


Figure 1-6.-Columnar data set.

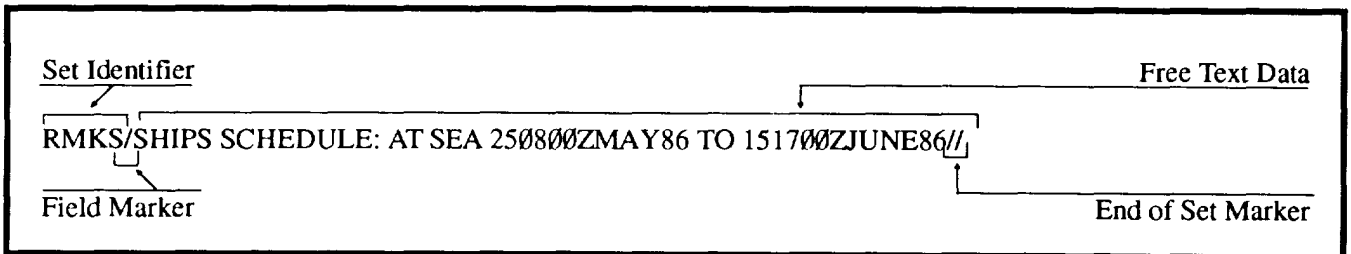


Figure 1-7.-Free text data set.

P 151744Z APR 86
 FM USS KITTY HAWK
 TO COMSECONDFLT
 CTG TWO ZERO PT TWO
 COMNAVAIRLANT NORFOLK VA
 NAVSSES PHILADELPHIA PA
 INFO AIG SIX EIGHT THREE FOUR
 NAVSEACOMBATSYSSENGSTA NORFOLK VA
 NUSC NEWPORT RI
 COMSPAWARSSYSCOM WASHINGTON DC
 NAVSHIPWPNSYSSENGSTA PORT HUENEME CA

BT

CONFIDENTIAL

MSGID/CASREP/CV 63 KITTY HAWK/27//

POSIT/4530N2-04645W9/151615ZAPR86//

CASUALTY/INITIAL-86012/NO 1 OXYGEN ANAL/EIC:F300/CAT:2//

ESTIMATE/302359ZMAY86/RECEIPT OF PARTS NLT 28 MAY 86//

ASSIST/OTHER/PHILADELPHIA//

AMPN/REQUEST ASSISTANCE FROM NAVSSES PHILA//

PARTSID/APL:490002/-/JCN:N03363-EB01-0802//

TECHPUB/NAVSEA 0956-LP-023-810//

IPARTS

/DL NATIONAL STOCK NO.	RQD	COSAL	ONBD	CIRCUIT
/01 9H5930-01-050-6624	001	000	000	—
/02 9H6630-01-049-0947	001	000	000	—//

AMPN/REASON ITEM NOT ONBOARD-NO ALLOWANCE ALL PARTS LISTED IN PARTSID APL//

1STRIP

/DL DOCUMENT ID	QTY	PRI	RDD	ACTIVITY	REQUISITION STATUS
/01 V03363-0094-W400	001	05	149	NNZ	131601ZAPR86
/02 V03363-0094-W401	001	05	149	NNZ	131601ZAPR86//

RMKS/ANALYZER FAILS TO GIVE ACCURATE CONTINUOUS READOUTS, CAUSING COMPLETE LOSS OF OXYGEN MONITORING CAPABILITY. CAUSES BELIEVED TO BE COMBINED ENVIRONMENT (HEAT AND HUMIDITY OF FIREROOMS) AND PARTS FAILURE. OXYGEN MONITORS HAVE NOT WORKED PROPERLY SINCE INSTALLATION DURING ROH 85. NAVSSES PROVIDED TECH ASSISTANCE IN JULY 1985. SHIP'S FORCE INSPECTION HAS NOW REVEALED HOLES IN BOTH TEFLON MEMBRANES. 5102 MISHAP REPORT BEING (NOT BEING) SUBMITTED. SHIPS SCHEDULE: INPORT PHILADELPHIA 14 MAY-12 JUN. CONSIDER 28-30 MAY IDEAL TIME TO OBSERVE UNITS IN OPERATION DUE TO INTENDED LIGHT OFF 28 MAY AFTER IMAV//
 DWNGRADE/DECL 30NOV86//

BT

(CLASSIFIED FOR ILLUSTRATIVE PURPOSES ONLY)

Figure 1-8.-Example of INITIAL CASREP requiring parts.

CASREP; best estimates of unavailable data should be provided in the INITIAL CASREP and revised as soon as possible in an UPDATE CASREP. An INITIAL CASREP may also be submitted to request outside assistance; that is, no parts are required to correct an equipment casualty (see fig. 1-9).

An INITIAL CASREP must identify, to an appropriate level of detail, the status of the equipment, parts, and assistance requirements. This is essential to allow operational and staff authorities to apply the proper priority to necessary resources. Each INITIAL CASREP must contain a casualty set followed by one or more sets that convey information concerning that casualty.

When a casualty results from inadequate general-purpose electronic test equipment (GPETE) or PMS, the affected system must be the subject of the INITIAL CASREP with GPETE or PMS reported as the cause in an amplification (AMPN) set.

An assist set must be used to report whether or not a unit requires outside assistance to repair an equipment casualty.

When a unit requires assistance and/or parts to repair a casualty, schedule information must be reported in the RMKS set for a full 30-day period, starting on the earliest date that the unit can receive the assistance and/or parts. In addition to the scheduling information, the unit commander may also report any effect the casualty is expected to have on the unit's employment during the 30-day period.

UPDATE CASREP.- An UPDATE CASREP is used to report information similar to that in the INITIAL CASREP. With the exception on the CASUALTY and ESTIMATES sets, only previously unreported casualty information or information that has been changed (or was reported in error) need be reported. Information in a previously reported data set may be changed by merely submitting the same data set again with the corrected

```

R 231325Z JUN 86
FM      USS INDEPENDENCE
TO      COMSECONDFLT
        COMCARGRU FOUR
        CTG TWO ONE PT ONE
        COMNAVAIRLANT NORFOLK VA
INFO    AIG SIX EIGHT FOUR THREE
        NAVAIRTESTCEN PATUXENT RIVER MD
        NAVELEXSYSEVALACT ST INIGOES MD
        NAVSHIPWPNSYSENGSTA PORT HUENEME CA
        NAVSHIPWPNSYSENGSTA NORFOLK VA
        COMSPAWARSYSCOM WASHINGTON DC

BT
CONFIDENTIAL
MSGID/CASREP/CV 62 INDEPENDENCE/82//
POSIT/NORFOLK/231138ZJUN86//
CASUALTY/INITIAL-86015/AN-SPN-42A LNDNG CON CEN/EIC:PD0M/CAT:3//
ESTIMATE/062100ZJUL86/NUMBER OF SORTIES AND POSSIBLE PROG CHG//
ASSIST/OTHER/NORFOLK//
AMPN/REQUEST NATC CHECK F-14 PROGRAM DURING FLIGHT OPS//
PARTSID/APL:18000003/-/JCN:N03362-EE01-0802//
RMKS/F-14 80 PCT ONE WIRE OR TAXI ONE ENGAGEMENTS POSSIBLE CAUSE-PITCH RAMP.
5102 MISHAP REPORT BEING (NOT BEING) SUBMITTED. SCHEDULE: FLIGHT OPS
03JUL86-10JUL86 VACAPES, INPORT 10JUL86-24JUL86 NORFOLK//
DWNGRADE/DECL 6JAN87//
BT

```

(CLASSIFIED FOR ILLUSTRATIVE PURPOSES ONLY)

Figure 1-9.-Example of INITIAL CASREP requiring outside assistance only.

information, except for ASSIST, 1PARTS, and 1STRIP sets. A unit must submit an UPDATE CASREP for a casualty when the following occurs:

- There is a need to complete information reporting requirements or to revise previously submitted information.
- The casualty situation changes; for example, the estimated repair date has changed, parts status has changed significantly, additional assistance is needed, and so forth.

- Additional malfunctions are discovered in the same item of equipment.
- All parts ordered to repair the equipment are received.
- Upon receipt of any significant part or equipment, inclusion of the date of receipt is required.

Only one casualty may be updated per UPDATE CASREP message. Figure 1-10 is an example of an UPDATE CASREP message.

```

P 141735Z MAY 86
FM    USS KITTY HAWK
TO    COMSECONDFLT
      CTG TWO ZERO PT TWO
      COMNAVAIRLANT NORFOLK VA
      NAVSSES PHILADELPHIA PA
INFO  AIG SIX EIGHT FOUR THREE
      NAVSHIPWPNSYSENGSTA PORT HUENEME CA
      NAVSHIPWPNSYSENGSTA NORFOLK VA
      COMSPAWARSYSCOM WASHINGTON DC
      NUSC NEWPORT RI

BT
CONFIDENTIAL
MSGID/CASREP/CV 63 KITTY HAWK/28//
POSIT/PHILADELPHIA/141715ZMAY86//
REF/CASREP/SARATOGA/131744ZMAY86//
CASUALTY/UPDATE-01-86012/NO 1 OXYGEN ANAL/EIC:F300/CAT:2//
ESTIMATE/302359ZMAY86/RECEIPT OF PARTS NLT 28 MAY 86//
AMPN/PARTS ORDERED PREVIOUSLY HAVE BEEN RECEIVED. REPAIRS CANNOT BE
COMPLETED UNTIL ADDITIONAL PARTS ARE RECEIVED//
CHANGE/1PARTS
/DL NATIONAL STOCK NO.   RQD     COSAL   ONBD   CIRCUIT
/03 UNKNOWN              002     000     000    —
/04 UNKNOWN              001     000     000    —//
AMPN/DL03-DL04 REASON ITEMS NOT ONBOARD-NO ALLOWANCE. PARTS NUMBERS
PROVIDED BY NAVSSES PHILA. DL03 PART NO. 098-022 DL04 PART NUMBER NO. 098-008 APL
DL03 49000001 DL04 49000002//
CHANGE/1STRIP
/DL DOCUMENT ID          QTY     PRI     RDD   ACTIVITY  REQUISITION STATUS
/03 V03360-0094-W402     002     05      149   NNZ       131403ZMAY86
/04 V03360-0094-W403     001     05      149   NNZ       131404ZMAY86//
RMKS/NAVSSES TECH REP IDENTIFIED ADDITIONAL PARTS REQUIRED. NO CHANGE IN
REPAIR SCHEDULE AT THIS TIME//
DWNGRADE/DECL 14DEC86//
BT

```

(CLASSIFIED FOR ILLUSTRATIVE PURPOSES ONLY)

Figure 1-10.-Example of an UPDATE CASREP message.

CORRECT CASREP.- A unit must submit a CORRECT CASREP when equipment that has been the subject of a casualty report is repaired and back in operational condition. Only one casualty correction may be submitted per CORRECT CASREP message. A CORRECT CASREP must be submitted as soon as possible after the casualty has been corrected. You should remember that the correction of a casualty may affect the unit's readiness rating and may require the submission of a SORTS report to report the change in

unit readiness. A list of data sets that are used in CORRECT CASREPs is shown in figure 1-11.

CANCEL CASREP.- A unit must submit a CANCEL CASREP when equipment that has been the subject of a casualty report is scheduled to be repaired during an overhaul period or other scheduled availability. Outstanding casualties that are not to be repaired during such availability must not be canceled and must be subject to normal follow-up procedures as previously specified.

DATA SET	DATA SET USAGE	DATA SET LIBRARY-FIGURE	COMMENTS
MSGID	Mandatory	4-26	Identifies the message type, originator, and serial number. Required once in each message.
POSIT	Mandatory	4-29	Identifies the reporting unit's present location and effective date-time. Required once in each message.
REF	Mandatory	4-30	Identifies date-time group of initial CASREP message.
CASUALTY	Mandatory	4-21	Identifies the casualty being corrected by its serial number, equipment description, and casualty category
AMPN	Mandatory	4-19	Reports the delay in correcting this casualty due to parts unavailability, the number of manhours expended in correcting this casualty, and the number of operating hours since last failure. Characterize equipment use as continuous, intermittent, or impulse.
RMKS	Optional	4-31	Provides additional amplifying information about this casualty. NAVEDTRACOM activities only: Report the total equipment downtime and student hours lost per course.
DWNGRADE	Conditional	4-24	If the message reporting this correction is classified, provides downgrading or declassification instructions. Required once in each classified message.

Figure 1-11.-CORRECT CASREP-order of data sets summary.

A CANCEL CASREP must be submitted upon the commencement of the availability period during which the casualty will be corrected. A list of data sets used in CANCEL CASREPS is provided in figure 1-12.

Timeliness

CASREPS should be submitted as soon as possible, but not later than 24 hours after the occurrence of a significant equipment casualty that cannot be corrected within 48 hours. Those units required to submit a SORTS report must do so within 4 hours of the time it is determined that the casualty has affected the unit's readiness status.

Precedence

CASREP messages must be assigned the lowest precedence consistent with the importance of the type of report, the unit's current operational schedule, the location, and the tactical situation. Deployed units must

assign a precedence of at least priority 4 to CASREP messages.

Addressal Procedures

As you can see by the example CASREP messages, the examples listed are commands, activities, and the like that are concerned with your unit's casualty. They may be a command or activity that will expedite the assistance as applicable. These addresses will vary with major geographical locations, such as the Pacific, Atlantic, Caribbean, and Mediterranean. The senior operational commander, immediate operational commander, and cognizant type commander, or designated deputy, must be action addressees on all CASREP messages. All other addressees can be found in NWP 10-1-10.

When writing CASREPs (INITIAL, UPDATE, CANCEL, and CORRECT), you should constantly refer to NWP 10-1-10 for proper format and terminology, as this chapter was written to give you a brief overview and not for you to use as an indepth guide.

DATA SET	DATA SET USAGE	DATA SET LIBRARY-FIGURE	COMMENTS
MSGID	Mandatory	4-26	Identifies the message type, originator, and serial number. Required once in each message.
POSIT	Mandatory	4-29	Identifies the reporting unit's present location and effective date-time. Required once in each message.
REF	Mandatory	4-30	Identifies date-time group of initial CASREP message.
CASUALTY	Mandatory	4-21	Identifies the casualty being cancelled by its serial number, equipment description, and casualty category.
AMPN	Conditional	4-19	Reports the reason for cancellation, e.g., location and date of scheduled availability.
RMKS	Optional	4-31	Provides additional amplifying information about this casualty.
DWNGRADE	Conditional	4-24	If the message reporting this cancellation is classified, provides downgrading or declassification instructions. Required once in each classified message.

Figure 1-12.-CANCEL CASREP-order of data sets summary.

REPORT NUMBER NAVSEA	TITLE	FORMAT	REFERENCE	
			FREQ CODE	NSTM CHAPTER
9070-2	Docking Report	NAVSEA 9070/1 9070/2 9070/3 9070/4 9070/5	S	Chap. 997 (9070) 094 (9080)
9000-1	Delivery Report upon Delivery of any Ship to any Government	Letter	S	094 (9080)
9880-2	Storm Damage to Ships--report of	Letter	S	100 (9110)
4710-2	Examination of Structure by Shipyards; report of	Letter or message	S	100 (9110)
4730-1	Periodic Cargo Tank Inspection & Tests (AO, AOR & AOG)	Letter	S	100 (9110)
9080-1	Report of Deep Dive	Letter	S	100 (9110)
3530-2	Magnetic Compass Table	NAVSEA 3120/4	S or every 12 mo.	252 (9240)
9291-2	Report of Solid Ballast Installation or Changes	Letter, Drawing or Sketch	S	096 9290
9290-1	Report of Excessive Rolling, Heeling or Pounding or Inadequate Propeller Immersion	Letter & 2 Data Sheets		096 (9290) 096 (9290)
9410-1	Main Propulsion Turbines; condition of	Letter	S	231 (9411)
9410-2	Turbine Lifting and Repair Report	NAVSEA 9410/4 9410/5 9410/6 9410/7 9410/8 9410/9	S	231 (9411)
9430-1	Bent or Cracked Shafts	Letter	S	243 (9430) 100 (9110)
9440-1	Report of Propeller Measurements	NAVSEA 420	S	245 (9440)
3960-1	Fuels & Lubricants, Testing of, by Naval Shipyards Laboratories	Letter	S	262 (9450)
9510-1	Boiler Settings on Safety Valve	Letter		221 (9510)
9500-1	Auxiliary Steam Turbines; Protection Against Excessive pressure, relief valves	Letter	S	551 (9490)
9510-6	Boiler Maintenance or Brickwork; Refractory Lining, Provision for Vibration	Letter	S	221 (9510)
9610-1	Submarine Battery Quarterly Report	NAVSEA 149	Q	223 (9623)
9620-6	Battery Water Analysis	Letter	S	223 (9623)
9620-1	Inspection of Submarine Battery Elements; report of	Letter	S	223 (9623)
9620-3	Battery Deficiency Report	Letter	S	223 (9623)
9720-5	Ammunition Handling & Stowage	Letter	S	700 (9780)
4440-4	Report of Change in Boats Status	NAVSEA 215	S	583 (9820)

LEGEND: Frequency code letters:

D--Daily	BM--Bi-Monthly
W--Weekly	Q--Quarterly
BW--Bi-Weekly	SA--Semi-Annually
SM--Semi-Monthly	A--Annually
M--Monthly	S--Situation

Figure 1-13.-Summary of situation reports.

SITUATION REPORTS

Situation reports (SITREPs) are one-time reports required when certain situations arise. Figure 1-13 is a

summary of one-time reports pertaining to the engineering department. The situation that occasions the reports listed in the summary are explained in the references listed.

CHAPTER 2

QUALITY ASSURANCE

LEARNING OBJECTIVES

Upon completion of this chapter, you will be able to do the following:

1. Describe the purpose and goal of the Quality Assurance (QA) program.
 2. Identify the chain of command for a QA program and the responsibilities of personnel in the chain of command.
 3. Describe QA personnel qualification requirements.
 4. Describe the operation of a QA program.
 5. Identify the definitions of terms used in QA.
 6. Describe the levels of essentiality.
 7. Identify the purpose of tests and inspections associated with the QA program.
 8. Describe the responsibilities of personnel conducting tests and inspections.
 9. Discuss the requirements and procedures in conducting a QA program inspection.
 10. Recognize the contents and format of various QA forms and reports.
 11. Identify the steps in preparing various QA forms and reports.
 12. Recognize the contents and format of other forms that are to be submitted in conjunction with QA forms and reports.
-

INTRODUCTION

As you progress towards IC1 or ICC, your responsibilities become more involved in quality assurance (QA). You will be responsible for ensuring that the work performed by your technicians and by outside help is completed with the highest quality possible. Most of the personnel in the IC rating take pride in the performance of their jobs and they normally strive for excellence.

As the work group or work center supervisor, one of your many responsibilities will be to ensure that all corrective action performed is done correctly and meets prescribed standards. Improper performance of repairs or installations could endanger the lives of personnel or an expensive piece of equipment or cause another piece of equipment to fail prematurely. A well-organized QA and inspection program will minimize the impact of a moment of carelessness or inattention. This chapter will familiarize you with the purpose, basic organization, and mechanics of the QA program.

You may be assigned as a QA representative or collateral duty inspector from time to time. As a work center supervisor, you will be responsible for the quality

control (QC) program in your workspaces. It is important that you become quality conscious. To make any program successful, you will have to know and understand the QA program and obtain the cooperation and participation of all your personnel. This requires you to ensure that all tests and repairs conform to their prescribed standards. In addition, you as a supervisor must train all your personnel in QC.

QUALITY ASSURANCE PROGRAM

The QA program was established to provide personnel with information and guidance necessary to administer a uniform policy of maintenance and repair of ships and submarines. The QA program is intended to impart discipline into the repair of equipment, safety of personnel, and configuration control, thereby enhancing ship's readiness.

The various QA manuals set forth minimum QA requirements for both the surface fleet and the submarine force. If more stringent requirements are imposed by higher authority, such requirements take precedence. If conflicts exist between the QA manual and previously issued letters and transmittals by the

appropriate force commanders, the QA manual takes precedence. Such conflicts should be reported to the appropriate officials.

The instructions contained in the QA manual apply to every ship and activity of the force. Although the requirements are primarily applicable to the repair and maintenance done by the force intermediate maintenance activities (IMAs), they also apply to maintenance done aboard ship by ship's force. In all cases, when specifications cannot be met, a departure from specifications request must be completed and reported.

Because of the wide range of ship types and equipment and the varied resources available for maintenance and repair, the instructions set forth in the QA manual are general in nature. Each activity must implement a QA program to meet the intent of the QA manual. The goal should be to have all repairs conform to QA specifications.

PROGRAM COMPONENTS

The basic thrust of the QA program is to ensure that you comply with technical specifications during all work on ships of both the surface fleet and the submarine force. The key elements of the program are as follows:

- **Administrative.** This includes training and qualifying personnel, monitoring and auditing programs, and completing the QA forms and records.
- **Job Execution.** This includes preparing work procedures, meeting controlled material requirements, requisitioning material, conducting in-process control of fabrication and repairs, testing and recertifying, and documenting any departure from specifications.

CONCEPTS OF QUALITY ASSURANCE

The ever-increasing technical complexity of present-day surface ships and submarines has spawned the need for special administrative and technical procedures known collectively as the QA program. The QA concept is fundamentally the prevention of defects. This encompasses all events from the start of maintenance operations until their completion. It is the responsibility of all maintenance personnel. Achievement of QA depends on prevention of maintenance problems through your knowledge and special skills. As a supervisor, you must consider QA requirements whenever you plan maintenance. The

fundamental rule for you to follow for all maintenance is that TECHNICAL SPECIFICATIONS MUST BE MET AT ALL TIMES.

Prevention is concerned with regulating events rather than being regulated by them. It relies on eliminating maintenance failures before they happen. This extends to safety of personnel, maintenance of equipment, and virtually every aspect of the total maintenance effort.

Knowledge is obtained from factual information. This knowledge is acquired through the proper use of data collection and analysis programs. The maintenance data collection system provides maintenance managers unlimited quantities of factual information. The experienced maintenance manager provides management with a pool of knowledge. Correct use of this knowledge provides the chain of command with the tools necessary to achieve maximum shipboard readiness.

Special skills, normally not possessed by production personnel, are provided by a staff of trained personnel for analyzing data and supervising QA programs.

The QA program provides an efficient method for gathering and maintaining information on the quality characteristics of products and on the source and nature of defects and their impact on current operations. It permits decisions to be based on facts rather than intuition or memory. It provides comparative data that will be useful long after details of particular times or events have been forgotten. QA requires both authority and assumption of responsibility for action.

A properly functioning QA program points out problem areas to maintenance managers so they can take appropriate action to accomplish the following:

- Improve the quality, uniformity, and reliability of the total maintenance effort.
- Improve the work environment, tools, and equipment used in the performance of maintenance.
- Eliminate unnecessary man-hour and dollar expenses.
- Improve the training, work habits, and procedures of maintenance personnel.
- Increase the excellence and value of reports and correspondence originated by the maintenance activity.

- Distribute required technical information more effectively.
- Establish realistic material and equipment requirements in support of the maintenance effort.

To obtain full benefits from a QA program, teamwork must be achieved first. Blend QA functions in with the interest of the total organization and you produce a more effective program. Allow each worker and supervisor to use an optimum degree of judgment in the course of the assigned daily work; a person's judgment plays an important part in the quality of the work. QA techniques supply each person with the information on actual quality. This information provides a challenge to the person to improve the quality of the work. The resulting knowledge encourages the best efforts of all your maintenance personnel.

QA is designed to serve both management and production equally. Management is served when QA monitors the complete maintenance effort of the department, furnishes factual feedback of discrepancies and deficiencies, and provides the action necessary to improve the quality, reliability, and safety of maintenance. Production is served by having the benefit of collateral duty inspectors formally trained in inspection procedures; it is also served in receiving technical assistance in resolving production problems. Production personnel are not relieved of their basic responsibility for quality work when you introduce QA to the maintenance function. Instead, you increase their responsibility by adding accountability. This accountability is the essence of QA.

GOALS

The goals of the QA program are to protect personnel from hazardous conditions, increase the time between equipment failure, and ensure proper repair of failed equipment. The goals of the QA program are intended to improve equipment reliability, safety of personnel, and configuration control. Achievement of these goals will ultimately enhance the readiness of ship and shore installations. There is a wide range of ship types and classes in the fleet, and there are equipment differences within ship classes. This complicates maintenance support and increases the need for a formalized program that will provide a high degree of confidence that overhaul, installations, repairs, and material will consistently meet conformance standards.

THE QUALITY ASSURANCE LINK TO MAINTENANCE

Accomplishment of repairs and alterations according to technical specifications has been a long-standing requirement for U.S. Navy ships. Ultimate responsibility to ensure that this requirement is met rests with the person performing the maintenance. To do the job properly, a worker must be

- properly trained,
- provided with correct tools and parts,
- familiar with the applicable technical manuals and plans, and,
- adequately supervised.

These elements continue to be the primary means of assuring that maintenance is performed correctly. As a supervisor, you can readily see where you fit in.

Once the need for maintenance is identified, you must consider QA requirements concurrent y with the planning and performing of that maintenance. Technical specifications will come from a variety of sources. The determination of which sources are applicable to the particular job will be the most difficult part of your planning effort. Once you make that determination, the maintenance objective becomes two-fold:

1. Ensure the maintenance effort meets all specifications.
2. Ensure the documentation is complete, accurate, and auditable.

It is vital that you approach maintenance planning from the standpoint of first-time quality.

THE QUALITY ASSURANCE ORGANIZATION

The QA program for naval forces is organized into different levels of responsibility. For example, the QA program for the Naval Surface Force for the Pacific Fleet is organized into the following levels of responsibility: type commander, readiness support group/area maintenance coordinator, and the IMAs. The QA program for the submarine force is organized into four levels of responsibility: type commander, group and squadron commanders, IMA commanding officers, and ship commanding officer/officers in charge. The QA program for the Naval Surface Force for the Atlantic Fleet is organized into five levels of responsibility: force

commander, audits, squadron commanders, IMAs, and force ships.

The QA program organization (Navy) begins with the commanders in chief of the fleets, who provide the basic QA program organization responsibilities and guidelines.

The type commanders (TYCOMs) provide instruction, policy, and overall direction for implementation and operation of the force QA program. TYCOMs have a force QA officer assigned to administer the force QA program.

The commanding officers (COs) are responsible to the force commander for QA in the maintenance and repair of the ships. The CO is responsible for organizing and implementing a QA program within the ship to carry out the provisions of the TYCOMs QA manual.

The CO ensures that all repair actions performed by ship's force conform to provisions of the QA manual as well as pertinent technical requirements.

The CO ensures that all work requests requiring special controls are properly identified and that applicable supporting documentation is provided to the maintenance or repair activity using the applicable QA form.

The CO also ensures that departures from specifications are reported, required audits are conducted, and adequate maintenance is performed for the material condition necessary to support continued unrestricted operations.

The quality assurance officer (QAO) is responsible to the CO for the organization, administration, and execution of the ship's QA program according to the QA manual. On most surface ships other than IMAs, the QAO is the chief engineer, with a senior chief petty officer assigned as the QA coordinate. The QAO is responsible for the following:

- Coordinating the ship's QA training program
- Maintaining ship's QA records and inspection reports according to the QA manual
- Maintaining auditable departure from specification records
- Reviewing procedures and controlled work packages prepared by the ship before submission to the engineer

- Conducting QA audits as required by the QA manual and following upon corrective actions to ensure compliance with the QA program
- Maintaining liaison with the IMA office for all work requiring QA controls
- Providing QA guidance to the supply department when required
- Preparing QA/QC reports (as required) by higher authority
- Maintaining liaison with the ship engineer in all matters pertaining to QA to ensure compliance with the QA manual

The **ship quality control inspectors (SQCIs)**, usually the work center supervisor and two others from the work center, must have a thorough understanding of the QA program. Some of the other responsibilities an SQCI will have are as follows:

- Maintain ship records to support the QA program.
- Inspect all work for conformance to specifications.
- Ensure that only calibrated equipment is used in acceptance testing and inspection of work
- Witness and document all tests.
- Ensure that all materials or test results that fail to meet specifications are recorded and reported.
- Train personnel in QC.
- Initiate departure from specification reports (discussed later) when required.
- Ensure that all inspections beyond the capabilities of the ship's QA inspector are performed and accepted by IMA before final acceptance and installation of the product by the ship.
- Report all deficiencies and discrepancies to the ship's QA coordinator (keeping the division officer informed).
- Develop controlled work packages for all ship repair work requiring QA controls.

More on SQCI duties will be discussed later in this chapter, because this will more than likely be the area you will be associated with.

RESPONSIBILITIES FOR QUALITY OF MAINTENANCE

Although the CO is responsible for the inspection and quality of material within a command, he or she depends on the full cooperation of all hands to meet this responsibility. The responsibility for establishing a successful program to attain high standards of quality workmanship cannot be discharged by merely creating a QA division within a maintenance organization. To operate effectively, this division requires the full support of everyone within the organization. It is not the instruments, instructions, and other facilities for making inspections that determine the success or failure in achieving high standards of quality, it is the frame of mind of all personnel.

Quality maintenance is vital to the effective operation of any maintenance organization. To achieve this high quality of work each of your personnel must know not only a set of specification limits, but also the purpose for these limits.

The person with the most direct concern for quality workmanship is you—the production supervisor. This stems from your responsibility for the professional performance of your assigned personnel. You must establish procedures within the work center to ensure that all QA inspection requirements are complied with during all maintenance evolutions. In developing procedures for your work center, keep in mind that inspections normally fall into one of the three following inspection areas:

- **RECEIVING OR SCREENING INSPECTIONS.** These inspections apply to material, components, parts, equipment, logs, records, and documents. These inspections determine the condition of material, proper identification, maintenance requirements, disposition, and correctness of accompanying records and documents.
- **IN-PROCESSING INSPECTIONS.** These inspections are specific QA actions that are required during maintenance or actions in cases where satisfactory task performance cannot be determined after maintenance has been completed. These inspections include witnessing, application of torque, functional testing, adjusting, assembling, servicing, and installation.
- **FINAL INSPECTION.** These inspections comprise specific QA actions performed

following the completion of a task or series of tasks. QA inspection of work areas following task completion by several different personnel is an example of a final inspection.

You have the direct responsibility as production supervisor to assign a collateral duty inspector at the time you assign work. This allows your inspector to make the progressive inspection(s) required; the inspector is not then confronted with a job already completed, functionally tested, and buttoned up. Remember, production personnel to which you have assigned the dual role of inspector cannot inspect or certify their own work.

SHIP QUALITY CONTROL INSPECTOR

The SQCI is the frontline guardian of adherence to quality standards. In the shops and on the deck plates, the SQCIs must constantly remind themselves that they can make a difference in the quality of a product. They must be able to see and be recognized for their contributions in obtaining quality results.

As a work center supervisor, you will be responsible for the QA program in your work spaces. You must realize that QA inspections are essential elements of an effective QA program. You are responsible to your division officer and the QAO for coordinating and administering the QA program within your work center. You are responsible for ensuring that all repaired units are ready for issue. This doesn't mean you have to inspect each item repaired in your shop personally; you should have two reliable, well-trained technicians to assist you in QA inspections. To avoid the many problems caused by poor maintenance repair practices or by the replacement of material with faulty or incorrect material, you must take your position as an SQCI very seriously. When you inspect a certain step of installation, ensure to the utmost of your knowledge and ability that the performance and product meet specifications and that installations are correct.

Most commands that have a QA program will issue you a special card that will identify you as a qualified SQCI for your command. Each of your shop SQCIs also will be assigned a personal serial number by the QAO as proof of certification to use on all forms and tags that require initials as proof that certified tests and inspections were completed. This will provide documented proof and traceability that each item or lot of items meets the material and workmanship for that stage of workmanship. Also, you will be given a QCI stamp so that you can stamp the QCI certification on the

forms or tags as a checkoff of a particular progressive step of inspection or final job completion. The stamp will also serve as proof of inspection and acceptance of each satisfactory shop end product. This stamp may have your command identification and a QCI number that is assigned and traceable to you.

As an SQCI, you should be thoroughly familiar with all aspects of the QA program and the QC procedures and requirements of your specialty.

You will be trained and qualified by the QAO according to the requirements set forth by your applicable QA manual and the QC requirements applicable to your installation. The QAO will interview you to determine your general knowledge of records, report completion, and filing requirements.

You will report to the appropriate QA supervisors while keeping your division officer informed of matters pertaining to QA work done in the shop. You and your work center QCIs will be responsible for the following:

- Developing a thorough understanding of the QA program.
- Ensuring that all shop work performed by your work center personnel meets the minimum requirements set forth in the latest plans, directives, and specifications of higher authority and that controlled work packages (CWPs) are properly used on repair work.
- Ensuring that all work center personnel are familiar with applicable QA manuals by conducting work center/division training.
- Maintaining records and files to support the QA program, following the QA manual.
- Assuring that your work center and, when applicable, division personnel do not use measuring devices, instruments, inspection tools, gauges, or fixtures for production acceptance and testing that do not have current calibration stickers or records attached or available.
- Performing quality control inspections of each product manufactured or repaired by your work center.
- Assisting your division officer and QAO in conducting internal audits as required and taking corrective action on noted discrepancies.

Alternate SQCIs are usually assigned as backups to the regular SQCIs. Their qualifications and

responsibilities will be the same as those of the regularly assigned SQCI.

WORK CENTER CONTROLLED MATERIAL PETTY OFFICERS

As a supervisor, you must also ensure that procedures governing controlled material are followed. You can do this by having one or more of your work center personnel trained in the procedures for inspecting, segregating, stowing, and issuing controlled material. When they have completed their training, designate them as controlled material petty officers (CMPOs).

SHOP CRAFTSMAN

As stated earlier, the person doing the work, whether it be manufacturing or repairing, is responsible to you when questions arise about the work being performed, whether the work is incorrect, incomplete, or unclear. Make sure your workers know to stop and seek work instructions or clarification from you when questions or conditions arise which may present an impediment to the successful completion of the task at hand.

A good lesson to teach over and over to all workers is to strive to achieve first-time quality on every task assigned. This not only will instill pride and professionalism in their work, but also will ensure a quality product.

QUALITY ASSURANCE REQUIREMENTS, TRAINING, AND QUALIFICATION

A comprehensive personnel training program is the next step in an effective QA program. For inspectors to make a difference, they must be both trained and certified. They must have formal or informal training in inspection methods, maintenance and repair, and certification of QA requirements. Costly mistakes, made either from a lack of knowledge or improper training, can be entirely eliminated with a good QA training program at all levels of shop or work group organization. Before personnel can assume the responsibility of coordinating, administering, and executing the QA program, they must meet certain requirements. Personnel assigned to the QA division or QC personnel you have assigned in your work center, such as SQCIs, CMPOs, or their alternates, should be highly motivated towards the QA program. It is imperative that a qualification and requalification program be established for those personnel participating in the program. Where

military standards and NAVSEA technical documents require formal technical training or equivalent, those requirements must be met and personnel qualification vigorously and effectively monitored to ensure that qualifications are updated and maintained. When formal training for a specific skill is not a requirement, the guidelines of the QA manual may be used as a basis for training to ensure that personnel are provided with the necessary expertise to perform a required skill. Personnel who obtain a QA qualification must undergo periodic QA training and examinations, both oral and written, to maintain the qualification. We will discuss this procedure in the following paragraphs.

QUALITY ASSURANCE OFFICER

The QAO's primary duty, assigned by the CO in writing, is to oversee the QA program. The QAO ensures that personnel assigned to perform QA functions receive continuous training in inspecting, testing, and QC methods specifically applicable to their area of assignment. The QAO also ensures that SQCIs receive cross training to perform QA functions not in their assigned area. This training includes local training courses, on-the-job training (OJT), rotation of assignments, personnel qualification standards (PQS), and formal schools.

Whenever possible, the QAO receives formal training according to the QA manual. He or she is responsible to the repair officer for planning and executing a QA training program for the various qualifications required for QA. The QAO personally interviews each perspective SQCI to ensure that the person has a thorough understanding of the QA mission.

REPAIR OFFICER

The repair officer (RO) maintains qualified personnel in all required ratings for the QA program in his or her department. He or she also ensures that personnel assigned to the repair department are indoctrinated and trained in QA practices and requirements.

DIVISION OFFICERS

Division officers ensure that their divisional personnel receive training and are qualified in the QA process and maintain those qualifications. They make sure that all repairs, inspections, and production work requiring a witness are witnessed by division work center QC inspectors and that all test records are completed and signed. Division officers ensure that all

test personnel observe all safety precautions pertaining to the specific equipment and wear personal safety equipment at all times while conducting these evolutions. They also make sure that test equipment, if required, is properly calibrated and that adequate overpressure protection is provided during tests in division spaces.

QUALITY ASSURANCE SUPERVISORS

QA supervisors are senior petty officers who have been properly qualified according to the QA manual. They have a thorough understanding of the QA function and are indoctrinated in all aspects of the coordinating, administering, and auditing processes of the QA program. QA supervisors train all SQCIs and CMPOs and ensure their recertification upon expiration of qualifications. QA supervisors also administer written examinations to all perspective SQCIs and those SQCIs who require recertification to ensure a thorough understanding of the QA program.

SHIP QUALITY CONTROL INSPECTORS

SQCIs are trained by the QA supervisors in applicable matters pertaining to the QA program. An inspector must be equally as skilled as the craftsman whose work he or she is required to inspect. Not only should the inspector know the fabrication or repair operation and what workers are required to do, but also how to go about doing it.

To recognize a product quality characteristic, SQCIs must be given certain tools and training. Tools of their trade should include measuring devices and documentation. Their training is both formal (documented course of instruction) and informal (OJT). They must pass a written test given by the QA supervisor, as well as an oral examination given by the QAO. The written exam includes general requirements of the QA program and specific requirements relative to their particular specialty. Successful completion of the shop qualification program course for QCIs will fulfill this requirement. The QA supervisor may also administer a practical examination to perspective SQCIs in which they will have to demonstrate knowledge of records and report completion, and tiling requirements. This will ensure that the SQCIs have a general knowledge of and proper attitude toward the QA program.

CONTROLLED MATERIAL PETTY OFFICERS

CMPOs are normally petty officers, E-4 or E-5, who are thoroughly familiar with controlled material requirements as outlined in the QA manual. They, too, are trained and qualified by a QA supervisor. The QAO will interview them, as he or she did for the SQCIs, to see if they have a general knowledge of controlled material requirements.

The QA supervisor will give them a written test to ensure that they have sufficient knowledge of controlled material requirements and procedures to carry out their responsibilities effectively.

OPERATION OF A QUALITY ASSURANCE PROGRAM

Initiating an effective, ongoing QA program is an all-hands effort. It takes the cooperation of all shop personnel to make the program work. As the shop or work group supervisor, you will be responsible for getting the program rolling.

The key elements are a good personnel orientation program, a comprehensive personnel training program, use of the proper repair procedures, and uniform inspection procedures. When you have organized the shop or work center and have placed all these elements in practice, your QA program will be underway. These elements are discussed in the following paragraphs.

PERSONNEL ORIENTATION

The best way to get the support of your personnel is to show them how an effective QA program will benefit them personally. Eliminating or reducing premature failures in repaired units and introducing high-reliability repairs will appreciably reduce their workload, saving them frustration and enhancing the shop or work group reputation. This program, as any new program or change to an existing program, will probably meet with opposition from some shop personnel. By showing your shop personnel the benefits of a QA program, you greatly reduce opposition to the change.

REPAIR PROCEDURES

Repair procedures may be defined as all of the action required to return an equipment to its proper operating condition after a defect has been discovered. Repair procedures include parts handling, disassembly, component removal or replacement, and reassembly,

Strictly adhering to the proper repair procedures will almost entirely eliminate premature failures. You, as shop supervisor or work group supervisor, and subordinate work center supervisors are responsible for ensuring that the proper procedures are used in handling all repairable units.

QUALITY ASSURANCE TERMS AND DEFINITIONS

As a supervisor, you need to be able to talk to your personnel about QA and have them be able to carry out your instructions properly and promptly. You need to promote the use of words and phrases pertaining to quality and related programs, thus improving the clarity in your communication with them about QA. To do this, you need to understand the terms frequently used throughout the QA program. Each TYCOM's QA manual and MIL-STD-109 has a complete list of these terms, but the most frequently used terms are listed here:

QUALITY ASSURANCE. Quality assurance (QA) is a system that ensures that materials, data, supplies, and services conform to technical requirements and that repaired equipment performs satisfactory.

QUALITY CONTROL. Quality control (QC) is a management function that attempts to eliminate defective products, whether they are produced or procured.

ACCEPTANCE. Acceptance is when an authorized representative approves specific services rendered (such as a repair or manufactured part).

CALIBRATION. This is the comparison of two instruments or measuring devices, one of which is a standard of known accuracy traceable to national standards, to detect, correlate, report, or eliminate by adjustment any discrepancy in accuracy of the instrument or measuring device being compared with the standard.

INSPECTION. This is the examination and testing of components and services to determine whether they conform to specified requirements.

IN-PROCESS INSPECTION. This type of inspection is performed during the manufacture and repair cycle to prevent production defects. It is also performed to identify production problems or material defects that are not detectable when the job is complete.

INSPECTION RECORD. Inspection records contain data resulting from inspection actions.

SPECIFICATIONS. A specification is any technical or administrative directive, such as an instruction, a technical manual, a drawing, a plan, or publication, that defines repair criteria.

AUDIT. An audit, as it applies to the QA program, is a periodic or special evaluation of details, plans, policies, procedures, products, directives, and records necessary to determine compliance with existing requirements.

CERTIFIED (LEVEL 1) MATERIAL. This is material that has been certified (as to its material and physical properties as well as traceability to the manufacturer) by a qualified certification activity. This material has a material and identification control (MIC) number assigned along with a certification document.

CONTROLLED MATERIAL. This is any material that must be accounted for and identified throughout the manufacturing or repair process. (See level of essentiality.)

CONTROLLED WORK PACKAGE. A controlled work package (CWP) is an assemblage of documents identified by a unique serial number that may contain detailed work procedures, purchase documents, receipt inspection reports, objective quality evidence, local test results, and any tags, papers, prints, plans, and soon that bear on the work performed. This will be discussed later in the chapter.

DEPARTURE FROM SPECIFICATION. This is a lack of compliance with any authoritative document, plan, procedure, or instruction. A detailed discussion will follow later in the chapter.

DOCUMENTATION. This is the record of objective evidence establishing the requisite quality of the material, component, or work done.

LEVEL OF ESSENTIALITY. A level of essentiality is a certain level of confidence required in the reliability of repairs made. The different levels of essentiality will be discussed later in the chapter.

PROCEDURE. A procedure is a written instruction designed for use in production and repair, delineating all essential elements and guidance necessary to produce acceptable and reliable products.

PROCESS. This is a set of actions written in a special sequential order by which a repair or

maintenance action, a test, or an inspection is done using specific guidelines, tools, and equipment.

RELIABILITY. Reliability means the probability that an item will perform its intended function for a specified interval under stated conditions.

SUBSAFE. The acronym SUBSAFE is a short reference to the Submarine Safety Program, which provides a high level of confidence in the material conditions of the hull integrity boundary. SUBSAFE will be discussed later in this chapter.

THE CONTROLLED WORK PACKAGE

To provide additional assurance that a quality product will result from the in-process fabrication or repair, the CWP was developed. It provides QC techniques (requirements or procedures) and shows objective quality evidence (documentation) of adherence to specified quality standards. These requirements or procedures include both external (TYCOM) and internal (command-generated) information for work package processing and sign-off. The typical CWP that will arrive at your desk will have QA forms, departure from specifications forms, material deficiency forms, production task control forms, and QC personnel sign-off requirements. You, and all the other work centers involved in the performance of the task, must review the contents of each package as well. When you review the package, check that the requirements specified for their accomplishment are correct, in a correct sequence, and so on. Each CWP covers the entire scope of the work process and is able to stand on its own. Traceability from the work package to other certification documentation is provided by the job control number (JCN).

You must ensure that the CWP is at the job site during the performance of the task. If the work procedure requires the simultaneous performance of procedure steps and these steps are done in different locations, use the locally developed practices to ensure you maintain positive control for each step.

Immediately after a job is completed, but before the ship gets underway, each assigned work center and the QAO will review the work package documentation for completeness and correctness. If you and your workers have been doing the assigned steps as stated, this should not be a problem. Ensure that all the verification signature blocks are signed. Make sure all references, such as technical manuals or drawings, are returned to the appropriate place.

ENCLOSURES

You will find a lot of documentation inside the CWP when it arrives at your desk. Inside will be process instructions, plans, technical drawings, and instructions pertinent to the production job at hand. Documents listed as references are not intended to be included in the CWP, but they must be available when required. You will also find a copy of applicable portions of references included in the CWP. In addition, the 4790/2R, Automated Work Request, is included within the CWP to provide for complete documentation and references back to the originating tended unit. You will use all of the documentation to perform the maintenance action, production task, or process assigned to your work center.

REVISIONS

You can make minor corrections, to the work procedure (as directed by local instructions) as long as they do not change the scope of the work being performed. However, you must initiate a revision when it becomes necessary to change the original scope of the job, such as a part not originally intended to be worked on. The revision cover sheet gives exact instructions on adding, deleting, or changing steps in the work sequence.

ADDENDUM

Depending on the complexity of the task, it may be desirable to have two or more work centers working portions of the task concurrently. Planning and estimating (P & E) will initiate an addendum to the original CWP. The addendum will include all the headings of the CWP-references material list, safety requirements, work sequence, and so forth. When you complete the work steps, include the addendum with the CWP.

LEVELS OF ESSENTIALITY, ASSURANCE, AND CONTROL

To provide your customers both repair quality and QA, you as a supervisor of a work center or a work group in an IMA and your maintenance personnel must understand and appreciate your customers and their operational environment. This will require that you and your personnel give serious thought and consideration to how a system's nonperformance may endanger personnel safety and threaten the ship's mission capability. For example, you are not going to be aboard the submarine as it does its deep dive to test hull integrity

(and your hull packing work). You must stress to your workers how system essentiality, in an operational environment, equates with mission capability and personnel safety. In other words, workers must understand how the work they perform in a maintenance or repair environment can seriously affect the operational capabilities of the tended unit as well as the safety of the personnel aboard the unit. This is where the assigned levels of essentiality, assurance, and control come into play. What do we mean by these terms? We will discuss each in the following paragraphs.

LEVELS OF ESSENTIALITY

A number of early failures in certain submarine and surface ship systems were due to the use of the wrong material. This led to a system for prevention involving levels of essentiality. A level of essentiality is simply a range of controls in two broad categories representing a certain high degree of confidence that procurement specifications have been met. These categories are

- verification of material, and
- confirmation of satisfactory completion of tests and inspections required by the ordering data.

Levels of essentiality are codes, assigned by the ship according to the QA manual, that indicate the degree to which the ship's system, subsystem, or components are necessary or indispensable in the performance of the ship's mission. Levels of essentiality also indicate the impact that catastrophic failure of the associated part or equipment would have on ship's mission capability and personnel safety.

LEVELS OF ASSURANCE

QA is divided into three levels: A, B, and C. Each level reflects certain quality verification requirements of individual fabrication in process or repair items. Here, verification refers to the total of quality of controls, tests, and/or inspections. The levels of assurance are as follows:

Level A: Provides for the most stringent or restrictive verification techniques. This normally will require both QC and test or inspection methods.

Level B: Provides for adequate verification techniques. This normally will require limited QC and may or may not require tests or inspections.

Level C: Provides for minimum or “as necessary” verification techniques. This normally will require very little QC or tests and inspections.

LEVELS OF CONTROL

QC may also be assigned generally to any of the three levels—A, B, or C. Levels of control are the degrees of control measures required to assure reliability of repairs made to a system, subsystem, or component. Furthermore, levels of control (QC techniques) are the means by which we achieve levels of assurance.

An additional category that you will see is level I. This is reserved for systems that require maximum confidence that the composition of installed material is correct.

CONTROLLED MATERIAL

Some material, as part of a product destined for fleet use, has to be systematically controlled from procurement, receipt, stowage, issue, fabrication, repair, and installation to ensure both quality and material traceability. Controlled material is any material you use that must be accounted for (controlled) and identified throughout the manufacturing and repair process, including installation, to meet the specifications required of the end product. Controlled material must be inspected by your CMPO for required attributes before you can use it in a system or component and must have inspection documentation maintained on record. You must retain traceability through the repair and installation process. These records of traceability must be maintained for 7 years (3 years aboard ship and 4 years in record storage). Controlled material requires special marking and tagging for identification and separate storage to preclude loss of control. The RO may designate as controlled material any material that requires material traceability.

Under this definition, controlled material has two meanings. The first meaning applies to items considered critical enough to warrant the label of controlled material. Your CMPOs will be responsible for inspecting the material when it is received, stowing it separately from other material, providing custody, and seeing that controlled assembly procedures are used during its installation.

The term *controlled material* is used in reference to material either labeled SUBSAFE or classed in one of

three levels of essentiality. (Strictly speaking, SUBSAFE is not a level of essentiality.)

SUBSAFE

To help you understand SUBSAFE, we will discuss a little of the background of the program. The Submarine Safety Program (hence the name SUBSAFE) was established in 1963 as a direct result of the loss of USS *Thresher*. The program is two-fold, consisting of both material and operability requirements. It provides a high level of confidence in the material condition of the hull integrity boundary and in the ability of a submarine to recover from control surface casualties and flooding,

SUBSAFE requirements are split into five categories, which are devoted to

- piping systems,
- flooding control and recovery,
- documentation,
- pressure hull boundary, and
- government-furnished material.

There are three SUBSAFE definitions you need to consider: SUBSAFE system, SUBSAFE boundary, and SUBSAFE material.

SUBSAFE System

A SUBSAFE system is any submarine system determined by NAVSEA to require the special material or operability requirements of the SUBSAFE program. How does it concern you? After you have installed and maintained a system, it must prevent flooding of the submarine, enhance recovery in the event of flooding, and ensure reliable ship control.

SUBSAFE Boundary

A SUBSAFE boundary marks the specific portion of a SUBSAFE system within which the stringent material or operability requirements of SUBSAFE apply.

SUBSAFE Material

Within the SUBSAFE boundary, two different sets of requirements apply—SUBSAFE and level I. What is the difference between the two? The difference is expressed by two words, *certification* and *verification*. Material certification pertains to the SUBSAFE

program. This means that an item certified as SUB SAFE meets a certain testing or fabrication requirement and can be used as intended in a critical hull integrity or pressure-containing role. On the other hand, material verification pertains to the level I program. An item specified as level I has had its material composition tested and verified. This testing and verification ensures traceability from the material back to a lot or batch to ensure that material composition complies with procurement specifications. This traceability from material back to lot or batch is done through the assigned controlled material number, either a locally assigned number or one assigned by the vendor.

DEPARTURE FROM SPECIFICATIONS

Specifications are engineering requirements, such as type of material, dimensional clearances, and physical arrangements, by which ship components are installed, tested, and maintained. All ships, surface and submarine, are designed and constructed to specific technical and physical requirements. As a supervisor, you must ensure your personnel make every effort to maintain all ship systems and components according to their required specifications. There are, on occasion, situations in which specifications cannot be met. In such cases, the system or component is controlled with a deviation from specification. To maintain a precise control of any ship's technical configuration, any deviation you make must be recorded and approved as a departure from specification.

DEFINING A DEPARTURE FROM SPECIFICATION

Plainly put, a departure from specification is a lack of compliance with an authoritative document, plan, procedure, or instruction. As a minimum, departures are required when the following situations occur:

- There is a lack of compliance with cognizant technical documents, drawings, or work procedures during a maintenance action that will not be corrected before the ship gets underway.
- There is a lack of compliance with specifications for "as found" conditions during a maintenance action for which no prior action is held (such as a shipyard waiver) that will not be corrected before the ship gets underway.
- There is a lack of compliance with a specification discovered and no corrective action is planned.

- A departure from specification is not required for nonconforming conditions discovered and not caused by maintenance or a maintenance attempt. Specifically, for items that routinely fail and for which corrective action is planned, only a CSMP entry is made.

SUPERVISOR'S REPORTING PROCEDURES

You and your workers who perform maintenance have an obligation to perform every repair according to specifications. When a departure is discovered, it is the responsibility of the person(s) finding it to report it.

There are several causes for workers failing to report departures from specifications. You must stress to all of your workers that any deviation from specifications must be recorded, reviewed, and approved by the proper authority. This is sometimes caused by the lack of adequate inspection, QC, and management of the process for determining compliance with specifications. Sometimes workers simply do not understand the specification requirements. Another cause is a lack of training in the skills necessary to meet specifications. The lack of time for adequate planning and parts procurement, thereby requiring an emergency temporary repair instead of a permanent repair, is another direct cause for workers failing to comply with specifications. From this discussion, you can see the role you as a supervisor play during this all-important process.

TYPES OF DEPARTURES FROM SPECIFICATIONS

There are two types of departures that affect you and the reporting procedures—major and minor. We will briefly discuss each of them in the following paragraphs.

Major Departure from Specifications

A major departure from specifications is any departure from specifications that affects the reliability of the ship's control systems, watertight integrity, or personnel safety. Major departures from specifications require approval from higher authority. If you have a departure from specifications that falls into any of the following categories, consider it a major departure:

- Any departure that directly involves the safety of the ship or personnel

- Any departure that reduces the integrity or operability of equipment essential to the ship's mission (for example, installation of parts that do not meet all applicable material certification requirements)
- Failure to complete any required retest of a component or subsystem that, if defective, could cause flooding
- Any nonconformance to plan specifications resulting in a change of configuration considered to be a permanent repair
- Failure to meet all applicable standards for major repairs unless other alternatives are authorized by the QA manual (in other words, failed strength test)

Minor Departure from Specifications

This includes all departures that are not determined to be major. Minor departures may be permanent or temporary and are approved by the RO.

REPORTING PROCEDURES

Who reports a departure from specification? Do you as the supervisor? Only if you are the one finding or causing the departure. As stated in the QA manual, the person discovering or causing the departure must initiate the departure from specification. However, does this mean that each time we cause a departure we immediately start the paper work? No! The originator must ensure that the departure is identified during fabrication, testing, or inspection of the completed work. He or she must make every effort to correct each deficiency before initiating the departure request. Work must not continue until the deficiency is corrected or the departure request is approved.

Now that we have identified a departure, what do we do with it? We go back to the originator. He or she must ensure that QA Form 12 (fig. 2-1) is properly filled out and forwarded via the chain of command to the QAO.

The originator must also retain a copy of the prepared departure request until he or she receives the returned copy from the QAO indicating that all actions concerning the departure have been completed (approved or disapproved).

Make sure that the originator has an approved copy of the departure request accompanying the completed work and that the original copy is retained in the CWP.

QUALITY ASSURANCE FORMS AND RECORDS

The following are the titles and descriptions of the forms and records you will use the most. A rule to remember when using these forms is that all QA forms must be completed and signed in the proper sequence.

QA FORM 1, MATERIAL RECEIPT CONTROL RECORD

This record (fig. 2-2) is used by the CMPO to document the proper receipt and inspection of items that have been designated as controlled materials.

QA FORM 2, MATERIAL IN-PROCESS CONTROL TAG

This tag (fig. 2-3) is attached by supply, QA, or shop personnel to provide traceability of accepted controlled material from receipt inspection through final acceptance.

QA FORM 3, CONTROLLED MATERIAL REJECT TAG

Shop personnel, supply, or QA personnel will attach this tag (fig. 2-4) to rejected items. The individual finding or causing the unacceptable condition attaches the tag to the rejected item. The tag indicates that material is unacceptable for production work and must be replaced or reinspected before use.

QA FORM 4, CONTROLLED MATERIAL SHIP-TO-SHOP TAG

This tag (fig. 2-5) is used to identify and control material to be repaired. You attach the tag to the item to be repaired. It is a good idea to stamp the three sections of the tag with a control number and log it in your shop log.

A FORM 4A, SHIP-TO-SHOP TAG (GENERAL USE)

This tag is used to identify and control material and equipment in a positive manner from ship to repair shop. This tag does not require a material control number. Instead it uses an equipment serial number, a job sequence number, and, if possible, a Navy standard stock number for maintaining positive control.

DEPARTURE FROM SPECIFICATION REPORT
SURFLANT 9090/12

FROM: _____
(ORIGINATOR)

DEPARTURE SERIAL NO. _____
DATE _____

TO: REPAIR OFFICER/ENGINEER OFFICER
VIA: QUALITY ASSURANCE OFFICER/COORDINATOR

UIC W/C JSN

SHIP & HULL NO. _____

1. TYPE DEPARTURE _____ CATEGORY _____ LEVEL CONTROL _____

2. SYSTEM/COMPONENT _____

3. LOCATION _____

4. NAVSHIPS DRAWING/PLAN NO./PIECE NO. _____

5. TAB/SIB/REFERENCE _____

6. APPLICABLE SPECIFICATIONS _____

7. SITUATION/DEGREE OF NON-COMPLIANCE _____

8. COMMENTS/RECOMMENDATIONS (TESTS CONDUCTED) _____

9. ANSWER REQUESTED BY _____

10. PASS TO CO _____ SQD _____ TYCOM _____ QA OFFICER/COORDINATOR

11. DEPARTURE REQUEST MSG DTG _____

12. COMNAV SURFLANT DEPARTURE ANSWER/MSG DTG _____ REPAIR OFFICER/ENGINEER OFFICER

13. FINAL DISPOSITION: CLEARED _____ CANCELLED _____ OTHER _____ MSG DTG _____

14. REMARKS _____

Figure 2-1.-QA Form 12, Departure from Specification Report.

CONTROLLED MATERIAL
RECEIPT INSPECTION REPORT
SURFLANT 9090/1

1. NOMENCLATURE	2. LEVEL / MIL-SPEC	3. MIC OR I.D. NUMBER
4. REQ. NUMBER	5. JULIAN DATE	6. NUMBER RECEIVED
7. NSN	8. VENDOR'S MARK	
9. ACCEPTABLE DOCUMENTATION FURNISHED <input type="checkbox"/> YES <input type="checkbox"/> NO	SIGNATURE	DATE
10. INSPECTION REQUIRED <input checked="" type="checkbox"/> - RECORDS REQUIRED <input type="checkbox"/> 0 - RECORDS NOT REQUIRED		
<input type="checkbox"/> MT <input type="checkbox"/> PT <input type="checkbox"/> RT <input type="checkbox"/> UT <input type="checkbox"/> VIS <input type="checkbox"/> CHEM <input type="checkbox"/> PHYS <input type="checkbox"/> SPOT CHECK <input type="checkbox"/> DIMEN <input type="checkbox"/> HARDNESS		
11. INSPECTION RESULTS / REMARKS AND SIGNATURE		
12. DISPOSITION <input type="checkbox"/> ACCEPT <input type="checkbox"/> REJECT		13. <input type="checkbox"/> UPGRADE <input type="checkbox"/> MIL - SPEC <input type="checkbox"/> LI
14. DOWNGRADE <input type="checkbox"/> MIL - SPEC <input type="checkbox"/> GENERAL STOCK <input type="checkbox"/> SOURCE	REJECT TO	15. SIGNATURE
		15A. DATE

Figure 2-2.-QA Form 1, Material Receipt Control Record.

**CONTROLLED MATERIAL
IN-PROCESS CONTROL TAG
SURFLANT 9090/2**

TAG ___ of ___

1. MIC NO. _____

2. MAT'L LEVEL LI NUC LI
 NUCL III MIL-SPEC OTHER

3. MAT'L DESCRIPTION _____

4. NSN _____
ISSUED FOR (J.O.) _____

UIC	WC	JSN

**CAUTION
ATTACHED MATERIAL
REQUIRES SPECIAL
HANDLING AND
PROCESS CONTROL**

GREEN QA FORM 2

QA FORM 2

IN-PROCESS CONTROL AND FINAL ACC.

5. WC NO. _____
REMARKS _____

QC INSPECTOR

6. WC NO. _____ DATE _____
REMARKS _____

QC INSPECTOR

7. WC NO. _____ DATE _____
REMARKS _____

QC INSPECTOR

8. INSTALLATION & FINAL ACCEPTANCE
REMARKS _____ DATE _____

NOT INSP. _____ QC INSP. _____
(WHEN REQ.) SHIP INSP. _____

USE QA FORM (5) FOR SUPPLEMENT
GREEN

Figure 2-3.-QA Form 2, Material In-Process Control Tag.

— of —

**CONTROLLED MATERIAL
REJECT TAG
SURFLANT 9090/3**

PART I

1. MIC / ID NUMBER
 LI NUC LI NUC LIII
 MIL-SPEC OTHER

2. REASON

3. FINAL DISPOSITION BY QA
A. ACCEPT AS:
B. DOWNGRADE TO:
C. RETURN TO SOURCE

4. REMARKS

QA FORM 3 QA OFF. APPROVED

PART II — of —

QA DISPOSITION REQUEST

5. MIC NO.
LOCATION

THE SUPPLY DEPARTMENT / SHOP QC INSPECTOR IS HOLDING THE FOLLOWING MATERIAL IN A REJECTED STATUS. THIS MATERIAL IS OF A CRITICAL NATURE AND FINAL DISPOSITION EVALUATION IS REQUIRED.
REASON

6. NOMENCLATURE

DATE
 REQUESTED BY

QA FORM 3

RED

Figure 2-4.-QA Form 3, Controlled Material Reject Tag.

QA FORM 7, CONTROLLED MATERIAL INVENTORY/RECORD

This form (fig. 2-6) is used by your CMPO to provide a standard inventory record of controlled material received and issued.

QA FORM 8, PRODUCTION TASK CONTROL FORM

This form (fig. 2-7) is used to standardize the format used for abbreviated and detailed production tasks for level 1, level A, and level B controlled work.

QA FORM 8A, MATERIAL REQUIREMENTS (CONTROLLED WORK PACKAGE ONLY)

This form is used to provide a list of required materials necessary to complete the work described on the OPNAV 479W2K, 4790/2R, and the QA Form 8.

— of —

**CONTROLLED MATERIAL
SHIP TO SHOP TAG
SURFLANT 9090/4**

PART I TAG — of —
 NUC LI LI NUCL OTHER
 THIS COPY TO BE FILED BY QA
 FROM USS _____ HULL NO. _____
 EQUIP. TYPE _____
 SER. NO. _____ MIC/ID NO. _____
 DEL TO SHOP BY _____ DATE _____
 REC. IN SHOP BY (QC INSP) _____
 REC. NO. _____
 JCN _____
 REMARKS _____

PART II READY FOR PICK UP TAG

TAG NO. _____ SHOP _____
 JCN _____ DATE _____
 FROM USS _____ HULL NO. _____
 EQUIP. DISC. _____
 MIC/ID NO. _____
 SHOP REP. SNO. _____
 PRESENT THIS TAG WHEN CALLING FOR MAT.

PART III CONTROLLED MATERIAL RECEIPT TAG

TAG NO. _____ SHOP _____
 JCN _____ DATE _____
 REC. IN SHOP BY (QC INSP) _____
 DEL. TO SHOP BY _____
 SHIP'S ENGINEER SHALL RETAIN THIS TAG AS A RECEIPT FOR MATERIAL DELIVERED TO SHIP

YELLOW TAG BLACK PRINTING

Figure 2-5.-QA Form 4, Controlled Material Ship-to-Shop Tag.

INVENTORY RECORD OF CONTROLLED MATERIAL DATE _____
 SURFLANT 9090/7

SHIP & HULL NO. _____ JSN _____ LEVEL OF ESSENTIALITY _____ WORK CENTER _____

JOB TITLE _____ MIC / I.D. NO. _____ DWG NO. # _____ PART NO. # _____

MIL-SPEC _____ SIZE _____ DESCRIPTION OF MATERIAL _____

NSN / COG _____ LOCATION _____ AMOUNT REC. _____ REQ. NO. _____

DATE	UIC	W/C	JSN	SYSTEM	AMOUNT USED	AMOUNT ON HAND	COG. SIGNATURE

REMARKS _____

SUBMIT TO Q.A. WHEN ITEM IS EXPENDED

Figure 2-6.-QA Form 7, Controlled Material Inventory/Record.

QA FORM 9, RE-ENTRY CONTROL FORM

This form (fig. 2-8) is used to document re-entry into a SUBSAFE boundary and is used in a controlled work procedure.

QA FORM 9A, RE-ENTRY CONTROL SUPPLEMENT SHEET

This sheet supplements QA Form 9 and is used to record additional information.

QA FORM 10, RE-ENTRY CONTROL LOG

The re-entry control log (fig. 2-9) is used to provide a chronological record of re-entry into SUBSAFE boundaries. Each time a QA Form 9 is used, the IMA, QAO, or ship's engineer must log the time issued and serial number assigned on QA Form 10.

QA FORM 13, QUALITY ASSURANCE INFORMATION SHEET

This form provides the IMA with the necessary information to develop a CWP before the start of work. When filled out, this sheet will be attached to the 4790/2K and delivered to the IMA. For CSMP entries, this form is delivered to the IMA at the pre-arrival conference.

QA FORM 15, REQUEST FOR RELEASE OF REJECTED MATERIAL OR WORKMANSHIP

Should there be an urgent and overriding requirement for the use of material or workmanship, the division officer/production officer may request that the repair officer and squadron material officer release rejected material or workmanship. For example, a shaft has been machined undersize, but it is determined that

RE - ENTRY CONTROL FORM (REC)
SURFLANT 90909

1. FOR USS	NOTE: USE ONLY ONE REC SHEET FOR EACH SYSTEM OR PLAN. USE REVERSE SIDE OR BLANK SHEET IF MORE SPACE IS REQUIRED. NOTE EACH BLANK SHEET WITH REC NO., REV., AND PAGE NUMBER OF TOTAL PAGES.	2. REC NO	REV
		3. PAGE	PAGES

4. REQUESTED BY (NAME OF PERSON)	5. ASSOCIATED RECS
6. SYSTEM RE-ENTERING (ENTER ONLY ONE)	7. PLAN NO (ENTER ONLY ONE)
8. START DATE	

9. REASON FOR REC	DIVISION OFFICER	ROUTINE	TROUBLE	(STATE REMARKS
____ ALTERATION	____ ACCESS FOR REC	____ MAINTENANCE	____ SHOOTING	____ RETEST
____ OTHER ON REVERSE)				

10. OTHER SYSTEMS AFFECTED BY THIS REC	11. INSPECTION REQUIRED
	____ RECEIPT ____ IN PROCESS ____ FINAL

12. BOUNDARIES

13. WORK DESCRIPTION

14. WORK AUTHORITY

15. REMARKS

16 APPROVAL TO DO WORK	TECHNICAL APPROVAL	DATE	SHIPS APPROVAL	DATE	FINAL APPROVAL	DATE
17. ABOVE WORK HAS BEEN SATISFACTORILY COMPLETED AND RETESTED	TECHNICAL APPROVAL	DATE	SHIPS APPROVAL	DATE	FINAL APPROVAL	DATE

18. IDENTITY OF SUPPORTING DOCUMENTS

19. ASSOCIATED REC'S COMPLETED	DATE	20. SHIPS C.O. RE-ENTRY COMPLETION CERTIFICATION	DATE
--------------------------------	------	--	------

Figure 2-8.-QA Form 9, Re-Entry Control Form.

MATERIAL DEFICIENCY REPORT
SURFLANT 9090/16

FROM: _____
 (ORIGINATOR) DATE _____

TO: REPAIR OFFICER

VIA: QUALITY ASSURANCE OFFICER

SUBJ: MATERIAL DEFICIENCY

USS	UIC	W/C	JSN	REJECT TAG #

1. TYPE DEFICIENCY

_____ RECEIPT _____ MANUFACTURING _____ INSTALLATION _____ TEST/INSPECTION

2. MATERIAL DESCRIPTION: _____

3. DESCRIPTION OF DEFICIENCY _____

4. RECOMMENDATION _____ REPLACE _____ REPAIR AS FOLLOWS _____ (ORIGINATOR)

OTHER _____

ACTION RECOMMENDED BY _____ APPROVED _____ DATE _____

QA OFFICER _____

APPROVED _____ DATE _____

REPAIR OFFICER _____

5. SUPPLY ACTION REQUIRED _____

6. SUPPLY ACTION INITIATED (INFO QA) _____

APPROVED _____ DATE _____

SUPPLY OFFICER

COPY TO: WHITE - QA OFFICE
 YELLOW - SUPPLY OFFICER (AS NECESSARY)
 PINK - ORIGINATOR

Figure 2-11.-QA Form 16, Material Deficiency Report.

TESTS AND INSPECTIONS
 (OTHER THAN NDT AND HYDROSTATIC)
 SURFLANT 9090/17

SHIP _____	UIC 	W/C 	JCN 	DATE _____
------------	---------	---------	---------	---------------

LEAD WORK CENTER _____
 DESCRIPTION OF ITEM/COMPONENT/SYSTEM _____

REFERENCES _____

DESCRIPTION OF TESTS/INSPECTIONS _____

COMMENTS _____

COMPLETED ACTION _____

ACCEPTED _____ REJECTED _____

WORK CENTER SHOP CRAFTSMAN _____ DATE _____

SHIPS REPRESENTATIVE _____ DATE _____

WORK CENTER QC INSPECTOR _____ DATE _____

COPY TO: WHITE QA OFFICE
 YELLOW LEAD WORK CENTER
 PINK SHIP QA OFFICER

Figure 2-12-QA Form 17, Test and Inspection Form-Other than NDT.

CHAPTER 3

SHIPS' DRAWINGS AND DIAGRAMS

LEARNING OBJECTIVES

Upon completion of this chapter, you should be able to do the following:

1. Describe the different types of ships' drawings.
 2. Describe the procedures in verifying the accuracy of ships' drawings and systems diagrams.
-

INTRODUCTION

Drawing or sketching is the universal language used by engineers, technicians, and skilled craftsmen. Whether this drawing is made freehand or with drawing instruments, it is needed to convey all the necessary information to the individual who will fabricate and assemble the object whether it be a building, a ship, an aircraft, or a mechanical device. If many people are involved in the fabrication of the object, copies (prints) are made of the original drawing or tracing so all persons involved will have the same information. Not only are drawings used as plans to fabricate and assemble objects, they are also used to illustrate how machines, ships, aircraft, and so on are operated, repaired, and maintained.

The chapter contains general information about the various types of ships' drawing and system diagrams that you should be familiar with as an IC1 or ICC. They include the following:

- Blueprints
- Electrical prints
- Electronic prints
- Electromechanical drawings
- Logic diagrams

As an IC1 or ICC, you should have an indepth knowledge of how to use, care for, update, and verify the accuracy of these drawings. Drawings have a variety of uses, and you, as a supervisor, will come to realize the importance of drawings.

BLUEPRINTS

Blueprints are reproduced copies of mechanical or other types of technical drawings. The term *blueprint reading* means interpreting the ideas expressed by others on drawings, whether the drawings are actually blueprints or not.

HOW PRINTS ARE MADE

A mechanical drawing is drawn with instruments such as compasses, ruling pens, T-squares, triangles, and french curves. Prints (copies) are reproduced from original drawings in much the same manner as photographic prints are reproduced from negatives.

The original drawings for prints are made by drawing directly on, or tracing, a drawing on a translucent tracing paper or cloth, using black waterproof (india) ink or a drawing pencil. This original drawing is normally called a tracing "master copy." These copies of the tracings are rarely, if ever, sent to a shop or job site. Instead, reproductions of these tracings are made and distributed to persons or offices where needed. These tracings can be used over and over indefinitely if properly handled and stored.

Blueprints are made from these tracings. The term *blueprints* is a rather loosely used term in dealing with reproductions of original drawings. One of the first processes devised to reproduce prints or duplicate tracings produced white lines on a blue background, hence the term *blueprints*. Today, however, other methods of reproduction have been developed, and they produce prints of different colors. The colors may be

brown, black, gray, or maroon. The differences are the types of paper and the developing processes used.

A patented paper identified as BW paper produces prints with black lines on a white background.

The ammonia process, or OZALIDS, produces prints with either black blue, or maroon lines on a white background.

Other processes that may be used to reproduce drawings, usually small drawings or sketches, are the office-type duplicating machines, such as the mimeograph and ditto machines. One other type of duplicating process rarely used for reproducing working drawings is the photostatic process in which a large camera reduces or enlarges a tracing or drawing. The photostat has white lines on a dark background when reproduced directly from a tracing or drawing. If the photostated print is then reproduced, it will have brown lines on a white background. Photostats are generally used by various businesses for incorporating reduced-size drawings into reports or records.

Military drawings and blueprints are prepared according to the prescribed standards and procedures in military standards (MIL-STDS). These MIL-STDS are listed in the *Department of Defense Index of Specifications and Standards*, issued as of 31 July of each year. Common MIL-STDS concerning engineering drawings and blueprints most commonly used by IC Electricians are listed by number and title as follows:

NUMBER	TITLE
MIL-STD-100E	Engineering Drawing Practices
MIL-STD-12D	Abbreviations For Use On Drawings
ANSI Y32.2	Graphic Symbols For Electrical and Electronics Diagrams
MIL-STD-15 Part No. 2	Electrical Wiring Equipment Symbols For Ships Plans, Part 2
ANSI Y32.9	Electrical Wiring Symbols For Architectural and Electrical Layout Drawings
MIL-STD-16C	Electrical and Electronic Reference Designations
MIL-STD-25A	Nomenclature and Symbols For Ship Structure

PARTS OF A BLUEPRINT

Military blueprints are prepared as to size, format, location of, information included in various blocks, and so on, according to MIL-STD-100E of 30 September 1991. The various parts of a blueprint are described briefly in the following paragraphs.

Title Block

The Title block is located in the lower right-hand corner of all blueprints and drawings prepared according to MIL-STDs. The block contains the drawing number, the name of the part or assembly that the blueprint represents, and all information required to identify the part or assembly. The Title block also includes the name and address of the government agency or organization preparing the drawing, the scale, drafting record, authentication, and the date (fig. 3-1).

A space within the Title block with a diagonal or slant line drawn across it (not shown in fig. 3-1) indicates that the information usually placed in it is not required or is given elsewhere on the drawing.

Revision Block

The Revision block (not shown) is usually located in the upper right-hand corner of the blueprint and is used for the recording of changes (revisions) to the print. All revisions are noted in this block and are dated and identified by a letter and a brief description of the revision. A revised drawing is shown by the addition of a letter to the original number, as shown in figure 3-1, view A. If the print shown in figure 3-1, view A, was again revised, the letter *A* in the Revision block would be replaced by the letter *B*.

Drawing Number

All blueprints are identified by a drawing number (NAVSHIP Systems Command number, fig. 3-1, view A, and Naval Facilities Engineering Command drawing number, fig. 3-1, view B), which appears in a block. It may be shown in other places also; for example, near the top border line in the upper corner, or on the reverse side at both ends so it will be visible when a drawing is rolled up. If a blueprint has more than one sheet, this information is included in the Number block indicating the sheet number and the number of sheets in the series. For example, note that in the Title block shown in figure 3-1, the sheet is sheet 1 of 1.

NNDWG NO. 0101 46		NEWPORT NEWS SHIPBUILDING & DRY DOCK CO. NEWPORT NEWS, VIRGINIA FSCM NO. 43489 HULL DESIGN DIV STRUCTURAL DEPT			
DRAWN <i>H.E. Baker</i> CHECKED <i>R.F. Coonan</i> SUPVR <i>L. Hanley</i> DATE <i>6/11/91</i>		TITLE AIRCRAFT CARRIER CVAN 68 DOUBLE BOTTOM AFT OF FRAME 180 COMPARTMENT & ACCESS.			
EXAMINED <i>E.W. TAYLOR</i> DATE COMPLETED <i>5/17/91</i>		APPROVED <i>D.E. Clark</i> DATE JUL 17 1991 <small>FOR SUPERVISOR OF SHIPBUILDING USN</small>			
AUTHORIZED		TYPE OF DWG WORKING DRAWING		SIZE H	CODE IDENT NO. 80064
				NAVSHIP SYSTEM COMMAND NO. 800 2647537	REV. A
		SCALE $\frac{1}{8} = 1 \text{ FT.}$		SHEET 1 OF 1	

A

DES. <i>R. HATHAWAY</i>		DEPARTMENT OF THE NAVY NAVAL FACILITIES ENGINEERING COMMAND U.S. NAVAL STATION, WASHINGTON, D.C.			
DRWN. <i>R. HATHAWAY</i>		<i>INSTALLATION OF NEW LIGHTING</i> <i>BLDG. 220-3E4</i> <i>WASHINGTON NAVY YARD</i>			
CHK. <i>B.W. Beck</i>					
SUPV. <i>T.A. Barrett</i>					
IN CHARGE <i>E. GRANT</i>					
SATISFACTORY TO <i>W.C. Johnson</i>		CODE IDENT NO. 80091		SIZE F	FEC DRAWING NO. 1167420
APPROVED <i>J.R. Jones</i> DATE <i>5/17/91</i> OFFICER IN CHARGE		SCALE $\frac{1}{8} = 1'$		SPEC. 82805/91 NBY 82805 SHEET 1 OF 1	
APPROVED <i>John S. Hayes</i> DATE <i>5/12/91</i> PUBLIC WORKS OFFICER					

B

Figure 3-1.-Blueprint Title blocks: (A) Naval Ship Systems Command; (B) Naval Facilities Engineering Command.

Reference Numbers

Reference numbers that appear in the title block refer to the number of other blueprints. When more than one detail is shown on a drawing, a dash and a number are frequently used. For example, if two parts are shown in one detail drawing, both prints would have the same drawing number, plus a dash and an individual number, such as 8117041-1 and 8117041-2.

In addition to appearing in the Title block, the dash and number may appear on the face of the drawings near the parts they identify. Some commercial prints show

the drawing and dash number and carry a leader line to the part; others use a circle, 3/8 inch in diameter around the dash number and carry a leader line to the point.

A dash and number are used to identify modified or improved parts and to identify right-hand and left-hand parts. Many parts on the right side of a piece of equipment are identical to the parts on the left side—in reverse. The left-hand part is usually shown in the drawing.

Above the Title block on some prints, you may see a notation such as 159674 LH shown; 159674-1 RH

opposite. Both parts carry the same number, but the part called for is distinguished by a dash and number. (LH means left hand and RH means right hand.) Some companies use odd numbers for right-hand parts and even numbers for left-hand parts.

Zone Numbers

Zone numbers on blueprints serve the same purpose as the numbers and letters printed on borders of maps to help you locate a particular point. To find a particular point, mentally draw horizontal and vertical lines from these letters and numerals. The point where these lines intersect is the particular point sought.

You will use practically the same system to help you locate parts, sections, and views on large blueprinted objects (for example, assembly drawings on ships' steering gear). Parts numbered in the Title block can be located on the drawing by looking up the numbers in squares along the lower border. Zone numbers read from right to left.

Scale

The scale of the blueprint is indicated in one of the spaces within the Title block. It indicates the size of the drawing as compared with the actual size of the part. The scale may be shown as $1" = 2"$, $1" = 12"$, $1/2" = 1'$, and so on. It also may be indicated as full size, one-half size, one-fourth size, and so on.

If a blueprint indicates that the scale is $1" = 2"$, each line on the print is shown one-half its actual length. If a blueprint indicates that the scale is $3" = 1'$, each line on the print is three times its actual length.

Very small parts are enlarged to show the views clearly, and large objects are normally reduced in size to fit on standard size drawing paper. In short, the scale is selected to fit the object being drawn and the space available on a sheet of drawing paper.

Remember: NEVER MEASURE A DRAWING. USE DIMENSIONS. Why? Because the print may have been reduced in size from the original drawing, or you might not take the scale of the drawing into consideration. Then too, paper stretches and shrinks as humidity changes, thus introducing perhaps the greatest source of error in actually taking a measurement by laying a rule on the print itself. Play it safe and **READ** the dimensions on the drawing; they always remain the same.

Graphical scales are often placed on maps and plot plans. These scales indicate the number of feet or miles

represented by an inch. A fraction is often used, such as $1/500$, meaning that one unit on the map is equal to 500 like units on the ground. A **LARGE-SCALE MAP** has a scale of $1" = 10'$; a map with a scale of $1" = 1,000'$ is considered a **SMALL-SCALE MAP**.

Various types and shapes of scales are used in preparing blueprints. Four common types are shown in figure 3-2.

ARCHITECTS' SCALES.— Architects' scales (fig. 3-2, view A) are divided into proportional feet and inches and are generally used in scaling drawings for machine and structural work. The triangular architects' scale usually contains 11 scales, each subdivided differently. Six scales read from the left end while five scales read from the right end. Figure 3-2, view A, shows how the $3/16$ -inch subdivision of the architects' scale is further subdivided into 12 equal parts representing 1 inch each, and the $3/32$ -inch subdivision is further subdivided into 6 equal parts representing 2 inches each.

ENGINEERS' SCALES.— Engineers' scales (fig. 3-2, view B) are divided into decimal graduations (10, 20, 30, 40, 50, and 60 divisions to the inch). These scales are used for plotting and map drawing and in the graphic solution of problems.

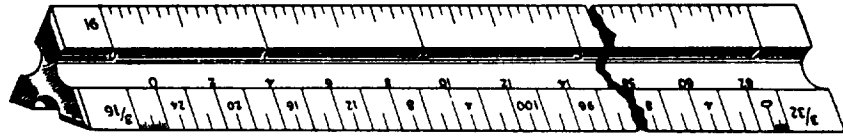
METRIC SCALES.— Metric scales (fig. 3-2, view C) are used with the drawings, maps, and so forth, made in countries using the metric system. This system is also being used with increasing frequency in the United States. The scale is divided into centimeters (cm) and millimeters (mm). In conversion, 2.54 cm are equal to 1 inch.

GRAPHIC SCALES.— Graphic scales (fig. 3-2, view D) are lines subdivided into distances corresponding to convenient units of length on the ground or of the object represented by the blueprint. They are placed in or near the Title block of the drawing and their relative lengths to the scales of the drawing are not affected if the print is reduced or enlarged.

Bill of Material Block

The Bill of Material block on a blueprint contains a list of the parts and materials used on or required by the print concerned. The block identifies parts and materials by stock number or other appropriate number and lists the quantity used or required.

The Bill of Material block often contains a list of standard parts, known as a parts list or schedule. Many commonly used items, such as machine bolts, screws, turnbuckles, rivets, pipefittings, and valves, have been



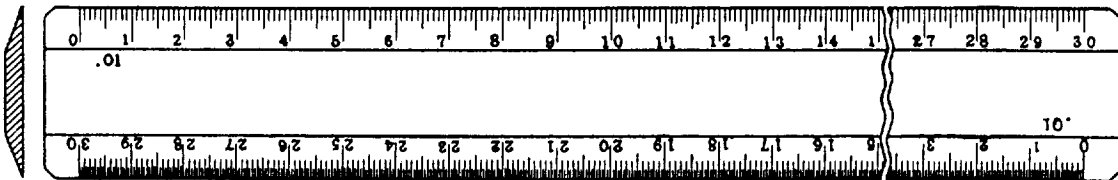
A

ARCHITECTS' SCALE



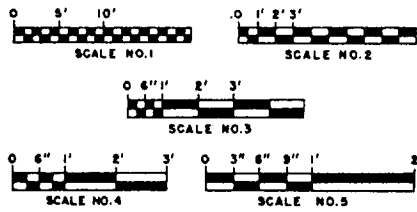
B

ENGINEERS' SCALE



C

METRIC SCALE



D

GRAPHIC SCALES

Figure 3-2. Types of scales.

standardized by the military. A Bill of Material block for an electrical plan is shown in figure 3-3.

Application Block

The Application block (fig. 3-4) is usually located near the Title block and identifies directly or by reference the larger units of which the detail part of assembly on the drawing forms a component. The Next Assembly column shows the drawing number or model number of the next larger assembly to which the drawing applies. The Used On column shows the model number or equivalent designation of the assembled units of which the part is a component.

NEXT ASS'Y	USED ON
APPLICATION	

Figure 3-4.-Application block.

Finish Marks

Finish marks (✓) are used on machine drawings to indicate surfaces that must be finished by machining. Machining provides a better surface appearance and provides the fit with closely mated parts. In manufacturing, during the finishing process, the required limits and tolerances must be observed. Machined finishes should not be confused with finishes

of paint, enamel, grease, chromium plating, and similar coatings.

Notes and Specifications

Blueprints contain all the information about an object or part that can be presented graphically-that is, in a drawing. A considerable amount of information can be presented this way, but supervisors, contractors, manufacturers, and craftsmen require more information that is not adaptable to the graphic form of presentation. Information of this type is given on the drawings as

BILL OF MATERIAL					
ITEM NO.	DESCRIPTION	UNIT	ASSEMBLY OR FSN NO.	QUANTITIES	
				TROP	NORTH
3 - 1	LIGHTING CIRCUIT - NAVFAC DWG NO. 283414	EA	3016	3	3
3 - 2	POWER BUS, 100A - NAVFAC DWG NO. 504131	EA	3047	1	1
3 - 3	RECEPTACLE CKT - NAVFAC DWG NO. 303668	EA	3019	2	2
3 - 4	BOX, RECEPTACLE W/CLAMP FOR NONMETALLIC SHEATH WIRE	EA	5325-102-604	5	5
3 - 5	LAMP ELECTRIC, MED BASE, INSIDE FROSTED, 200 W, 120 V	EA	6240-180-314	60	60
3 - 6	PLUG: ATTACHMENT, 3 WIRE, 15 AMP, 125 V	EA	5935-102-309	10	10
3 - 7	PLATE: BRASS, DUPLEX RECEPTACLE	EA	5325-600-101	5	5
3 - 8	RECEPTACLE, DUPLEX, 3 WIRE, 15 AMP, 125 V	EA	5325-100-102	5	5
3 - 9	ROD, GROUND, 3/4" x 10'-0"	EA	5306-200-180	12	12
3 - 10	WIRE, NO. 2 1/C STRANDED, HARD DRAWN, BARE	LB	6145-134-200	52	52
3 - 11	SWITCH, SAFETY, 2 P, ST 30 AMP, 250 V, PLUG FUSE	EA	5930-142-401	2	2
3 - 12	CLAMP, GROUND ROD	EA	5209-100-101	15	15
3 - 13	SWITCH, SAFETY, 200 AMP, 250 V, 3 P	EA	5930-201-903	1	1
3 - 14	FUSE, RENEWABLE, 200 AMP, 250 V	EA	5920-100-000	6	6
3 - 15	LINK, FUSE, 200 AMP, 250 V	EA	5920-100-001	6	6
	FUSE PLUG, 30 AMP, 125 V	EA	5920-100-102	12	12

Figure 3-3.-Bill of Material block.

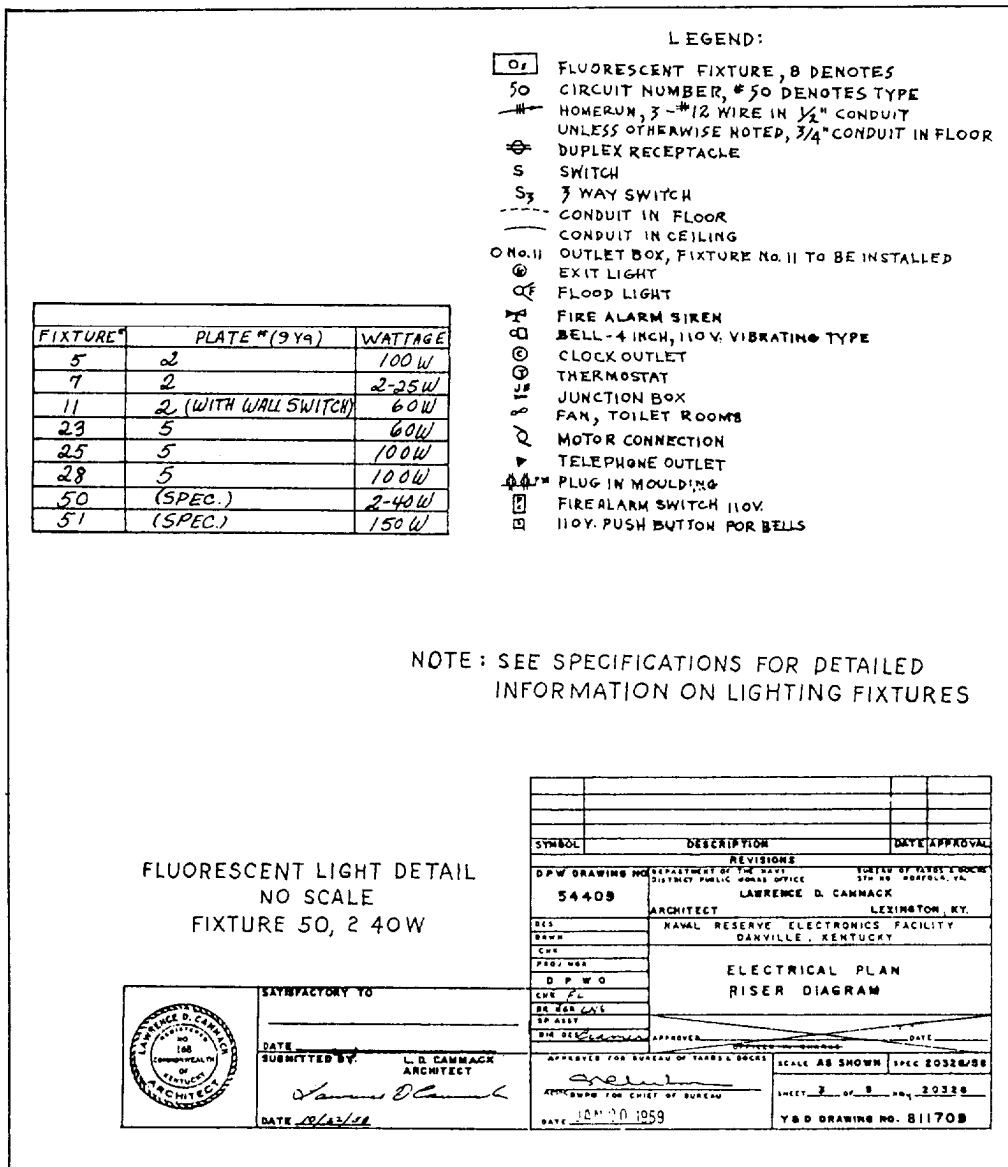


Figure 3-5.-An electrical plan.

notes or as a set of specifications attached to the drawings.

Notes are placed on drawings to give additional information to clarify the object on the blueprint. Leader lines are used to indicate the precise part being notated.

A specification is a statement or document containing a description or enumeration of particulars, as the terms of a contract or details of an object or objects not shown on a blueprint or drawing.

Specifications (specs) describe items so they may be procured, assembled, and maintained to function according to the performance requirements; furnish sufficient information to permit determination of conformance to the description; and furnish the information in sufficient completeness for accomplishment without the need of research,

development, design engineering, or help from the preparing organization.

Federal specifications cover the characteristics of material and supplies used jointly by the Navy and other government departments. All federal specifications used by the Navy Department as purchase specifications are listed in the Department of Defense Index of Specifications and Standards.

Legend or Symbols

The legend, if used, is placed on the upper right-hand corner of a blueprint below the Revision block. The legend explains or defines a symbol or special mark placed on a blueprint. Figure 3-5 shows a legend for an electrical plan.

Meaning of Lines

To be able to read and verify blueprints, you must acquire a knowledge of the use of lines. The alphabet of lines is the common language of the technician and the engineer.

In drawing an object, a draftsman not only arranges the different views in a certain reamer, but also uses different types of lines to convey information. Line characteristics, such as width, breaks in the line, and zigzags, have meaning, as shown by figure 3-6. Figure 3-7 shows the use of standard lines in a simple drawing.

SHIPBOARD BLUEPRINTS

Various types of blueprints (usually referred to as plans) are used in the construction, operation, and maintenance of Navy ships. The common types are as follows:

- Preliminary plans—Submitted with bids or other plans before award of a contract
- Contract plans—Illustrate design features of the ship that are mandatory requirements
- Contract guidance plans—Illustrate design features of the ship subject to development
- Standard plans—Illustrate arrangement or details of equipment, systems, or components for which specific requirements are mandatory
- Type plans—Illustrate general arrangement of equipment, systems, or components that are not necessarily subject to strict compliance as to details, provided the required results are accomplished
- Working plans—Contractor's construction plans that are necessary for construction of the ship
- Corrected plans—Working plans that have been corrected to illustrate the final ship and system arrangement, fabrication, and installation
- Onboard plans—A designated group of plans illustrating those features considered necessary for shipboard reference.

HANDLING BLUEPRINTS

Blueprints are valuable permanent records that can be used over and over if necessary. However, if you are to keep these prints as permanent records, you must

handle them with care. Here are a few simple rules to follow to preserve these prints.

- Keep prints out of strong sunlight because they will fade.
- Do not allow prints to become wet or smudged with oil or grease. Oil and grease seldom dry out completely; therefore, if the prints become wet or smudged with oil or grease, they become practically useless.
- Do not make pencil or crayon notations on a print without proper authority. If you receive instructions to mark a print, use an appropriate colored pencil and make the markings a permanent part of the print. Yellow is a good color to use on a print with a blue background (blueprint).
- Keep prints stowed in their proper place so they can be readily located the next time you want to refer to them.

Most of the prints you will handle will be received properly folded. Your main concern will be to refold them correctly. You may, however, have occasion to receive prints that have not been folded at all or that have been folded improperly.

The method of folding prints depends upon the type and size of the filing cabinet and the location of the identifying marks on the prints. It is preferable to place identifying marks at the top of prints when filing them vertically and at the bottom right-hand corner when filing (hem flat). In some cases, construction prints are stored in rolls.

ELECTRICAL PRINTS

Navy electrical prints are used by the IC Electrician in the installation, maintenance, and repair of shipboard electrical equipment and systems. These prints include various types of electrical diagrams as defined in the following paragraphs.

PICTORIAL WIRING DIAGRAM—A diagram that shows actual pictorial sketches of the various parts of a piece of equipment and the electrical connections between the parts.

ISOMETRIC WIRING DIAGRAM—A diagram that shows the outline of a ship or aircraft or other structure and the location of equipment, such as panels and connection boxes and cable run.


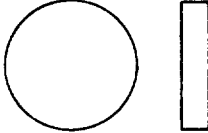



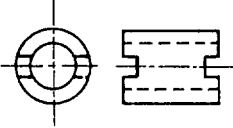

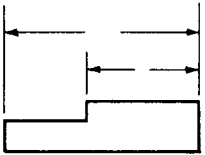

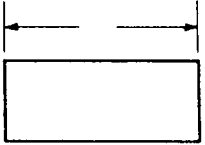
LINE STANDARDS			
NAME	CONVENTION	DESCRIPTION AND APPLICATION	EXAMPLE
VISIBLE LINES		HEAVY UNBROKEN LINES USED TO INDICATE VISIBLE EDGES OF AN OBJECT	
HIDDEN LINES		MEDIUM LINES WITH SHORT EVENLY SPACED DASHES USED TO INDICATE CONCEALED EDGES	
CENTER LINES		THIN LINES MADE UP OF LONG AND SHORT DASHES ALTERNATELY SPACED AND CONSISTENT IN LENGTH USED TO INDICATE SYMMETRY ABOUT AN AXIS AND LOCATION OF CENTERS	
DIMENSION LINES		THIN LINES TERMINATED WITH ARROW HEADS AT EACH END USED TO INDICATE DISTANCE MEASURED	
EXTENSION LINES		THIN UNBROKEN LINES USED TO INDICATE EXTENT OF DIMENSIONS	

Figure 3-6.-Line characteristics and conventions for MIL-STD drawings.

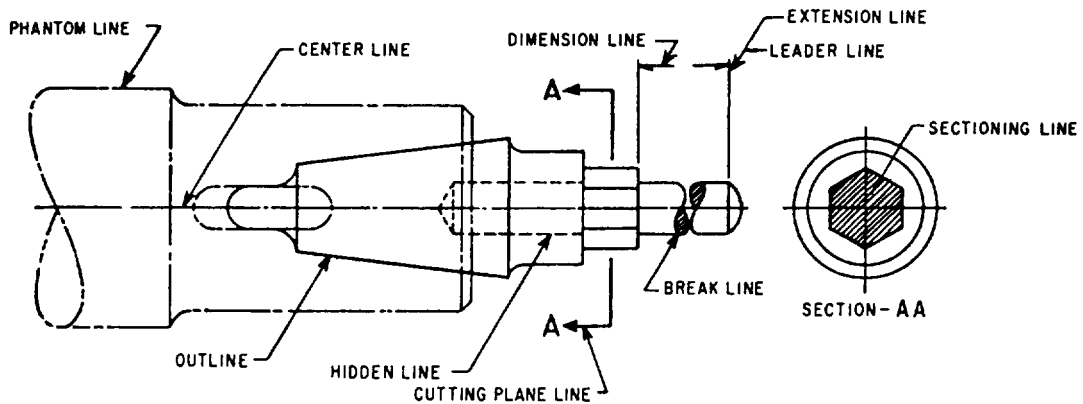


Figure 3-7.-Use of standard lines.

WIRING (CONNECTION) DIAGRAM—A diagram that shows the individual connections within a unit and the physical arrangement of the components.

SCHEMATIC DIAGRAM—A diagram that uses graphic symbols to show how a circuit functions electrically.

ELEMENTARY WIRING DIAGRAM—(1) A shipboard wiring diagram that shows how each conductor is connected within the various connection boxes of an electrical circuit or system. (2) A schematic diagram; the term *elementary wiring diagram* is sometimes used interchangeably with schematic diagram, especially a simplified schematic diagram.

BLOCK DIAGRAM—A diagram in which the major components of a piece of equipment or system are represented by squares, rectangles, or other geometric figures, and the normal order of progression of a signal or current flow is represented by lines.

SINGLE-LINE DIAGRAM—A diagram that uses single lines and graphic symbols to simplify a complex circuit or system.

To be able to read and verify the accuracy of any type of blueprint, you must be familiar with the standard symbols used for the type of print concerned. Reading electrical blueprints requires a knowledge of various types of standard symbols and, in addition, a knowledge of the methods of marking electrical conductors, cables, and equipments.

SHIPBOARD ELECTRICAL PRINTS

Various types of electrical drawings and diagrams are used in the installation and maintenance of shipboard electrical circuits, systems, and components.

To interpret shipboard electrical prints, you must be able to recognize the graphic symbols for electrical diagrams and the electrical wiring equipment symbols for ships as shown in ANSI/IEEE STD 315A-1986 and MIL-STD-15-2. Common symbols from these standards are shown in table 3-1. In addition, you must also be familiar with the shipboard system of numbering electrical units and marking electrical cables as described in the following paragraphs.

NUMBERING ELECTRICAL UNITS

Electrical units and other shipboard machinery and equipment are numbered as described in the following paragraphs.

All similar units in the ship comprise a group, and each group is assigned a separate series of consecutive numbers beginning with 1. Numbering begins in the lowest foremost starboard compartment, and the next compartment selected is to port of the first if it contains similar units; otherwise, the next aft on the same level.

Proceeding from starboard to port and from forward to aft, the numbering procedure continues until all similar units on the same level have been numbered; then it continues on the next upper level, and so on, until all similar units on all levels have been numbered. Within each compartment, the numbering of similar units proceeds from starboard to port, forward to aft, and from a lower to a higher level. Within a given compartment, then, the numbering of similar units follows the same rule; that is, lower takes precedence over aft, and starboard takes precedence over port.

Electrical distribution panels, control panels, and so on, are given identification numbers made up of three numbers separated by hyphens. The first number indicates the vertical level, at which the unit is normally accessible, by deck or platform number. Decks of Navy ships are numbered using the main deck as the starting point. The numeral 1 is used for the main deck. Each successive deck above the main deck is numbered 01, 02, 03, and so on, and each successive deck below the main deck is numbered 2, 3, 4, and so on.

The second number indicates the longitudinal location of the unit by frame number. The third number indicates the transverse location by the assignment of consecutive odd numbers for centerline and starboard locations and consecutive even numbers for port locations. The numeral 1 indicates the lowest centerline (or centermost) starboard component. Consecutive odd numbers are assigned components as they would be observed first as being above and then outboard of the preceding component. Consecutive even numbers similarly indicate components on the port side. For example, a distribution panel with the identification number 1-142-2 will be located on the main deck at frame 142 and will be the first distribution panel on the port side of the centerline at this frame on the main deck.

Main switchboards or switchgear groups supplied directly from ship's service generators are designated 1S, 2S, 3S, and so on, as necessary to designate all ship's service switchboards. Switchboards supplied directly by emergency generators are designated 1E, 2E, 3E, and so on, as necessary to designate all emergency switchboards. Switchboards for special frequency (other than the frequency of the ship's service system) have ac generators designated 1SF, 2SF, and so on, as necessary to designate all special frequency switchboards.

Table 3-1.-Electrical Symbols





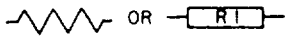









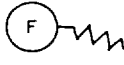





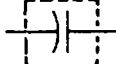
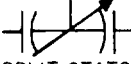




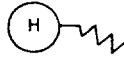
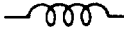

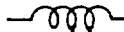

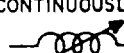
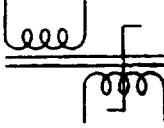














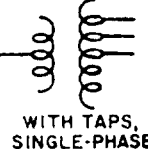








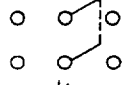
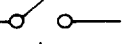











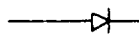
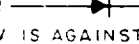
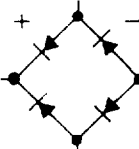


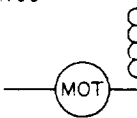

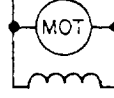









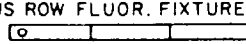









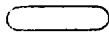
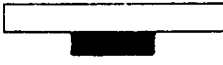
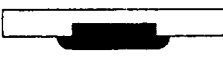




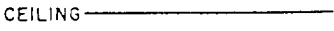
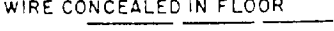
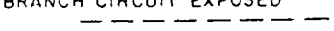
SHIPBOARD SYMBOLS		GRAPHIC SYMBOLS
<p>APPLIANCES; MISCELLANEOUS WIRING (GENERAL)</p> 	<p>CONTROLLER, MOTOR (GENERAL)</p>  <p>BUILDUP EXAMPLES</p> <p>CONTROLLER WITH LOW VOLTAGE RELEASE, RECLOSES UPON RETURN OF POWER</p>  <p>CONTROLLER WITH LOW VOLTAGE PROTECTION, REMAINS OPEN UPON RETURN OF POWER</p> 	<p>RESISTORS</p>  <p>GENERAL TAPPED </p> <p>ADJUSTABLE TAP </p> <p>CONTINUOUSLY VARIABLE </p> <p>NONLINEAR </p>
<p>BOXES, GENERAL</p>  <p>BRANCH </p> <p>CONNECTION </p> <p>DISTRIBUTION </p> <p>JUNCTION </p>	<p>FANS</p> <p>FAN, PORTABLE BRACKET</p>  <p>FAN, OVERHEAD</p> 	<p>CAPACITORS</p> <p>FIXED  VARIABLE  TRIMMER </p> <p>GANGED  SHIELDED </p> <p>SPLIT-STATOR  FEED-THROUGH </p>
<p>BUS TRANSFER EQUIPMENT</p> <p>NONAUTOMATIC OR PUSH BUTTON CONTROL</p> <p>AC </p> <p>DC </p>	<p>HEATERS</p> <p>HEATER, GENERAL</p>  <p>HEATER, PORTABLE RADIANT</p> 	<p>INDUCTIVE COMPONENTS</p> <p>GENERAL </p> <p>MAGNETIC CORE </p> <p>TAPPED </p> <p>ADJUSTABLE </p> <p>ADJUSTABLE OR CONTINUOUSLY ADJUSTABLE </p> <p>SATURABLE CORE REACTOR </p>
<p>COMMUNICATION EQUIPMENT</p> <p>BOX, SWITCH, TELEPHONE</p>  <p>JACKS </p> <p>PLUGS, TELEPHONE</p> 	<p>LIGHTING UNITS</p> <p>BULKHEAD</p>  <p>BULKHEAD, BERTH</p>  <p>HAND LANTERN</p>  <p>NAVIGATIONAL</p>  <p>NIGHT FLIGHT</p>  <p>OVERHEAD</p>  <p>PORTABLE</p>  <p>OVERHEAD, FLUORESCENT</p> 	<p>TRANSFORMERS</p> <p>GENERAL </p> <p>MAGNETIC CORE TRANSFORMER </p> <p>AUTOTransformer </p> <p>WITH TAPS, SINGLE-PHASE </p>
<p>RECEPTACLE OR OUTLET</p> 		
<p>SWITCH</p> <p>PUSH BUTTON </p> <p>ON-OFF </p> <p>SELECTOR</p> <p>CIRCUIT LETTER PANEL OR BULKHEAD NUMBER OF SECTIONS </p> <p>SNAP </p> <p>TRANSFER </p>		

Table 3-1.-Electrical Symbols-Continued

GRAPHIC SYMBOLS		
<p>SWITCHES</p> <p>GENERAL (SINGLE THROW) </p> <p>GENERAL (DOUBLE THROW) </p> <p>TWO POLE DOUBLE THROW SWITCH </p> <p>KNIFE SWITCH </p> <p>PUSHBUTTON (MAKE) </p> <p>PUSHBUTTON (BREAK) </p> <p>PUSHBUTTON TWO CIRCUIT </p> <p>CIRCUIT PROTECTORS</p> <p>FUSE </p> <p>FUSE OR OVERLOAD </p>	<p>CIRCUIT AIR BREAKERS</p> <p>SWITCH </p> <p>THERMAL </p> <p>GANGED </p> <p>BATTERIES</p> <p>ONE CELL </p> <p>MULTICELL </p> <p>TAPPED MULTICELL </p> <p>(LONG LINE IS ALWAYS POSITIVE)</p> <p>RECTIFIERS</p> <p>GENERAL </p> <p>SEMICONDUCTOR </p> <p>(ELECTRON FLOW IS AGAINST THE ARROW)</p> <p>FULL WAVE BRIDGE TYPE </p>	<p>ROTATING MACHINES</p> <p>MOTOR (MOT) </p> <p>GENERATOR (GEN) </p> <p>TYPES OF WINDINGS</p> <p>SERIES </p> <p>SEPARATELY EXCITED </p> <p>SHUNT </p> <p>DYNAMOTOR </p> <p>WINDING SYMBOLS</p> <p>SINGLE-PHASE </p> <p>TWO-PHASE </p> <p>THREE-PHASE (WYE) </p> <p>THREE-PHASE (DELTA) </p>
ARCHITECTURAL SYMBOLS		
<p>SINGLE RECPT. OUTLET </p> <p>DUPLEX RECPT. </p> <p>CEILING INCAN. LIGHT </p> <p>SINGLE FLUOR. FIXTURE </p> <p>CONTINUOUS ROW FLUOR. FIXTURE </p> <p>EXIT LIGHT (CEILING) </p> <p>EXIT LIGHT (WALL) </p> <p>JUNCTION BOX </p> <p>CLOTHES DRYER OUTLET </p>	<p>FLOOR DUPLEX RECPT. OUTLET </p> <p>SINGLE POLE SWITCH S </p> <p>THREE WAY SWITCH S₃ </p> <p>SWITCH FOR LOW VOLTAGE SYSTEM SL </p> <p>THERMOSTAT T </p> <p>PUSH BUTTON STATION MOTOR CONTROLLER </p> <p>WIRE CONCEALED IN FLOOR </p> <p>RECESSED PANEL </p>	<p>PUSH BUTTON BELL OR SIGNAL </p> <p>BUZZER </p> <p>CHIME CH </p> <p>BELL TRANSFORMER BT </p> <p>WIRE CONCEALED IN WALL OR CEILING </p> <p>WIRE CONCEALED IN FLOOR </p> <p>BRANCH CIRCUIT EXPOSED </p>

CABLE MARKING

Metal tags embossed with the cable designation are used to identify all permanently installed shipboard electrical cables. These tags (fig. 3-8) are placed on cables as close as practicable to each point of connection, on both sides of decks, bulkheads, and other barriers to provide identification of the cables for maintenance and replacement.

Two systems of cable marking (the old and the new) are in use aboard Navy ships. The old system uses the color of the tag to show cable classification (red-vital, yellow-semivital, and gray or no color-nonvital), and the following letters to designate power and lighting cables for the different services:

- C-Interior communications
- D-Degaussing
- F-Ship's service lighting and general power
- FB-Battle power
- G-Fire control
- MS-Minesweeping
- P-Electric propulsion
- R-Radio and radar
- RL-Running, anchor, and signal lights
- S-Sonar
- FE-Emergency light and power

Other letters and numbers are used with these basic letters to further identify the cable and complete the designation. Common marking of a power system for successive cables from a distribution switchboard to load would be feeder, FB-411; main, 1-FB-411; submain, 1-FB-411-A; branch, 1-FB-411-A1; and subbranch, 1-FB-411-A1A. The feeder number, 411, is indicative of the system voltage. The feeder numbers for a 117- or 120-volt system would range from 100 to 190; for a 220-volt system, from 200 to 299; and for a 450-volt system, from 400 to 499. The exact designation

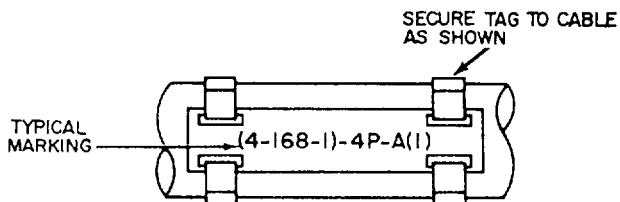


Figure 3-8.-Cable tag.

for each cable is shown on the ship's electrical wiring prints.

The new cable marking system for power and lighting cables consists of three parts in sequence: source, voltage, and service, and where practicable, destination. These parts are separated by hyphens.

The letters used to designate the different services are as follows:

- C-Interior communications
- D-Degaussing
- G-Fire control
- K-Control power
- L-Ship's service lighting
- N-Navigational lighting
- P-Ship's service power
- R-Electronics
- CP-Casualty power
- EL-Emergency lighting
- EP-Emergency power
- FL-Night flight
- MC-Coolant pump power
- MS-Minesweeping
- PP-Propulsion power
- SF-Special frequency power

In the new system, voltages below 100 volts are designated by the actual voltage; for example, 24 volts for a 24-volt circuit. The numeral 1 is used to indicate voltages between 100 and 199; 2 for voltages between 200 and 299; 4 for voltages between 400 and 499; and so on. For a three-wire (120/240) dc system or a three-wire 3-phase system, the number used indicates the higher voltage.

The destination of cables beyond panels and switchboards is not designated except that each circuit alternately receives a letter, a number, a letter, and a number, progressively, every time that it is fused. The destination of power cables to consuming equipment is not designated except that each cable to such equipment receives a single-letter alphabetical designation, beginning with the letter A.

Where two cables of the same power or lighting circuit are connected in a distribution panel or terminal box, the circuit classification is not changed. However, the cable markings have a suffix number (in parentheses) indicating the cable section. For example,

(4-168-1)-4P-A(1) (fig. 3-8) identifies a 450-volt power cable supplied from a power distribution panel on the fourth deck at frame 168 starboard. The letter *A* indicates that this is the first cable from the panel, and the (1) indicates that it is the first section of a power main with more than one section.

The power cables between generators and switchboards are labeled according to the generator designation. When only one generator supplies a switchboard, the generator will have the same number as the switchboard plus the letter *G*. Thus, 1SG denotes one ship's service generator that supplies the number 1 ship's service switchboard. When more than one ship's service generator supplies a switchboard, the first generator determined according to the general rule for numbering machinery will have the letter *A* immediately following the designation; the second generator that supplies the same switchboard will have the letter *B*. This procedure is continued for all generators that supply the switchboards. Thus, 1SG and 1SGB denote two ship's service generators that supply ship's service switchboard 1S.

Representative cable markings for power and lighting circuits are listed and explained in table 3-2.

PHASE AND POLARITY MARKINGS

Phase and polarity in ac and dc electrical systems are designated by a wiring color code as shown in table 3-2. Neutral polarity, where it exists, is identified by the white conductor.

ISOMETRIC WIRING DIAGRAM

An isometric wiring diagram is supplied for each shipboard electrical system. If the system is not too large, the isometric wiring diagram will be covered by one blueprint. For large systems, several prints may be required to show the complete system. An isometric wiring diagram shows the ship's decks arranged in tiers. Bulkheads and compartments are shown, the centerline is marked, and the frame numbers are shown (usually every five frames). The outer edge of each deck is drawn to show the general outline of the shape of the ship. All athwartship lines are shown at an angle of 30 degrees to the centerline. Cables running from one deck to another are drawn as lines at right angles to the centerline. A cable, regardless of the number of conductors, is represented on an isometric diagram by a single line. The various electrical fixtures are identified by a symbol number and their general location is shown. Thus, the isometric wiring diagram shows a rough picture of the entire circuit layout.

Table 3-2. Electrical Power and Lighting Cable Markings

Cable Marking	Remarks
6SG-4P-6S	450-volt generator power cable for ship service switchboard #6 supplied from ship service generator #6.
6S4P-7S	450-volt bus-tie power cable between ship service switchboard #6 and #7.
3SA-4P-3SB	450-volt switchboard inter-connecting power cable between sections A and B of the switchboard.
6S-4P-31	450-volt BUS FEEDER power cable from #6 switchboard supplying load center switchboard #1 in zone 3.
31-4P-(3-125-2)	450-volt power FEEDER cable from load center switchboard #1 in zone 3 supplying power distribution panel 3-125-2.
(3-125-2)-4P-C	450-volt MAIN power cable supplied from power distribution panel 3-125-2, the third cable from the panel.
(3-125-2)-1P-C1	120-volt SUBMAIN power cable supplied from power panel 3-125-2, the first cable fed through a transformer by the MAIN listed above.
(3-125-2)-1P-C1B	120-volt BRANCH power cable supplied from power panel 3-125-2, the second cable fed by the submain listed above.
(3-125-2)-1P-C1B2	120-volt SUBBRANCH power cable supplied from power panel 3-125-2, the second cable fed by the branch listed above.
1E-1EL-A	120-volt MAIN emergency, lighting cable supplied from #1 emergency switchboard-the first cable from the switchboard.
2-38-1)-1L-A1	120-voh SUBMAIN ship service lighting cable supplied from lighting panel 2-38-1.
(2-38-1)-1L-A1C3	120-volt SUBBRANCH ship service lighting cable supplied from lighting panel 2-38-1-the third cable supplied by BRANCH cable (2-38-1)-1L-A1C.

WIRING DECK PLAN

The wiring deck plan is the actual installation diagram for the deck or decks shown and is a blueprint used chiefly in ship construction. It enables the shipyard electrician to lay out the work for a number of cables without referring to each isometric wiring diagram. The plan includes a bill of material that lists all the materials and equipment necessary to complete the installation for the deck or decks concerned. Equipment and materials except cables are identified by a symbol number both on the drawing and in the bill of material.

Wiring deck plans are drawn to scale (usually 1/4 inch to the foot); therefore, they show the exact location of all fixtures. One blueprint usually shows from 150 to 200 feet of deck space on one deck only. Electrical wiring equipment symbols from MIL-STD-15-2 are used to represent fixtures as in the isometric wiring diagram.

ELEMENTARY WIRING DIAGRAM

The elementary wiring diagram shows in detail each conductor, terminal, and connection in a circuit. Elementary wiring diagrams are used to check for proper connections in a circuit or to make the initial hookup.

In IC circuits, for example, the lugs on the wires to each connection box are stamped with the conductor marking. The elementary wiring diagrams show the conductor markings alongside each conductor and how they are connected in the circuit. Elementary wiring diagrams usually do not show the location of connection boxes, panels, and soon; therefore, they are not drawn to any scale.

ELECTRICAL SYSTEMS DIAGRAMS

Various types of electrical systems are installed aboard Navy ships that include many types of electrical devices and components. These devices and components may be located throughout the ship. The electrical diagrams and drawings necessary to operate and maintain these systems are provided by the ship's electrical blueprints and by drawings and diagrams contained in *NSTMs* and manufacturers' technical manuals.

BLOCK DIAGRAMS

Block diagrams of electrical systems show the major units of the system in block form. These diagrams are used with text material to present a general description of the system and how it functions. Figure 3-9 shows a block diagram of the electrical steering system.

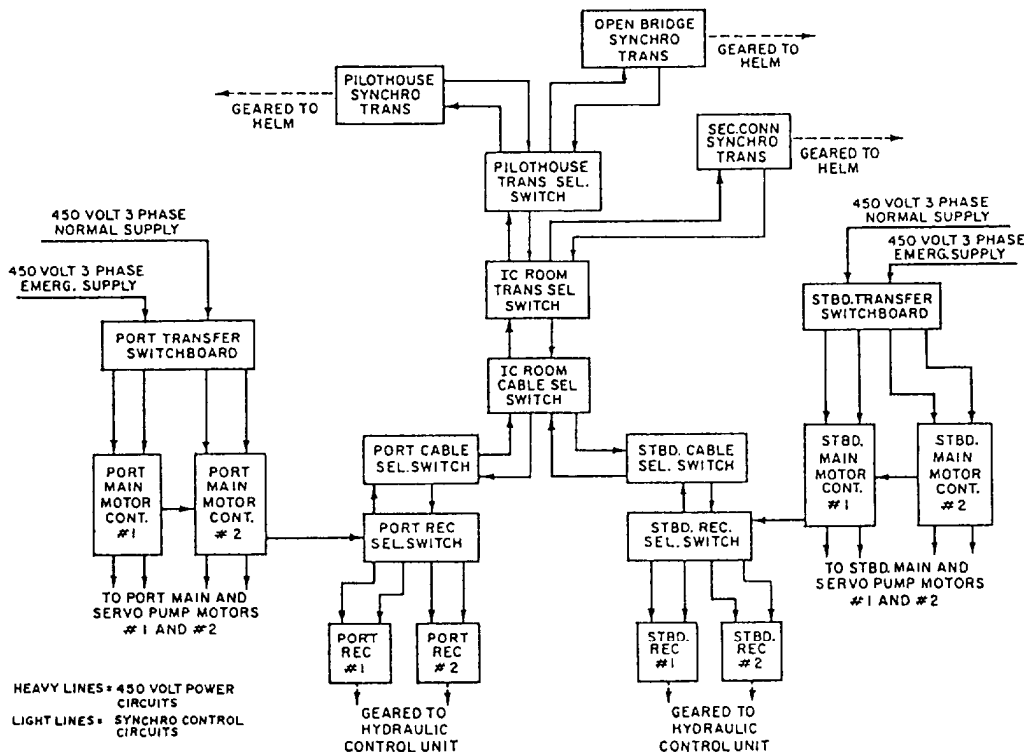
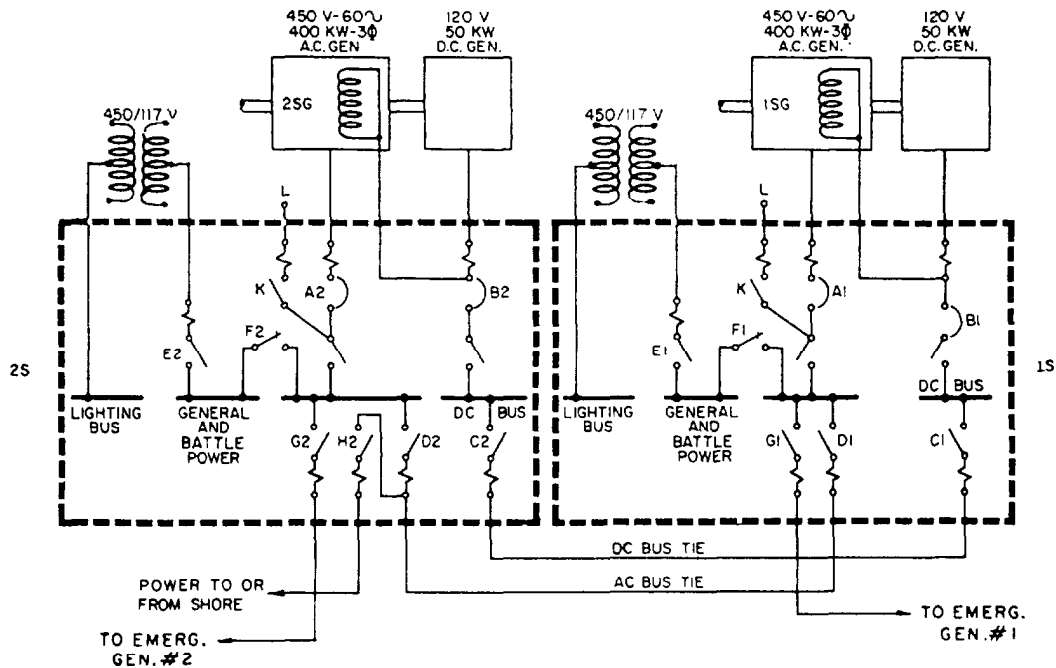


Figure 3-9.-Block diagram of a steering system.



- | | |
|--|---|
| <ul style="list-style-type: none"> A. Ac Generator Circuit Breaker B. Dc Generator Circuit Breaker C. Dc Bus Tie Circuit Breaker D. Ac Bus Tie Circuit Breaker E. Ac Lighting Circuit Breaker F. Ac Battle and General Power Circuit Breaker | <ul style="list-style-type: none"> G. Emergency Generator Bus Circuit Breaker H. Shore Power Circuit Breaker J. Emergency Generator Circuit Breaker K. AQB Casualty Power Breaker L. Casualty Power Terminal |
|--|---|

Figure 3-10. Single-line diagram of a ship's service generator and switchboard interconnections.

system for a large ship. This diagram along with the information in the following paragraph present the functional operation of the overall system.

The steering gear system (fig. 3-9) consists of one complete synchro-controlled electric hydraulic system for each rudder (port and starboard). The two steering systems are similar in all respects. They are separate systems, but they are normally controlled by the same steering wheel (helm) and operate to move both port and starboard rudders in unison.

SINGLE-LINE DIAGRAMS

Single-line diagrams are also used to present a general description of a system and to show how it functions. The single-line diagram presents more detail concerning the system than the block diagram, and thus requires less supporting text material.

Figure 3-10 shows a single-line diagram of the ship's service generator and switchboard connections for a destroyer. This diagram shows the type of ac and dc generators used to supply power for the ship and

presents, in simplified form, the actual switching arrangements for paralleling the generators, for supplying the different power and lighting busses, and for energizing the casualty power terminals.

EQUIPMENT WIRING DIAGRAMS

Equipment wiring diagrams are used to troubleshoot a system or a piece of equipment effectively. Where the block diagram is useful in presenting the functional operation of a system or equipment, the equipment wiring diagram gives a detailed representation of various components. The wiring diagram shows the relative location of resistors, transformers, diodes, terminal boards, and so on, and how each conductor is connected in the circuit.

Figure 3-11, view A, shows the main motor controller wiring diagram for the steering system in figure 3-9. The wiring diagram could be used to troubleshoot, check for proper electrical connections, or completely rewire the controller.

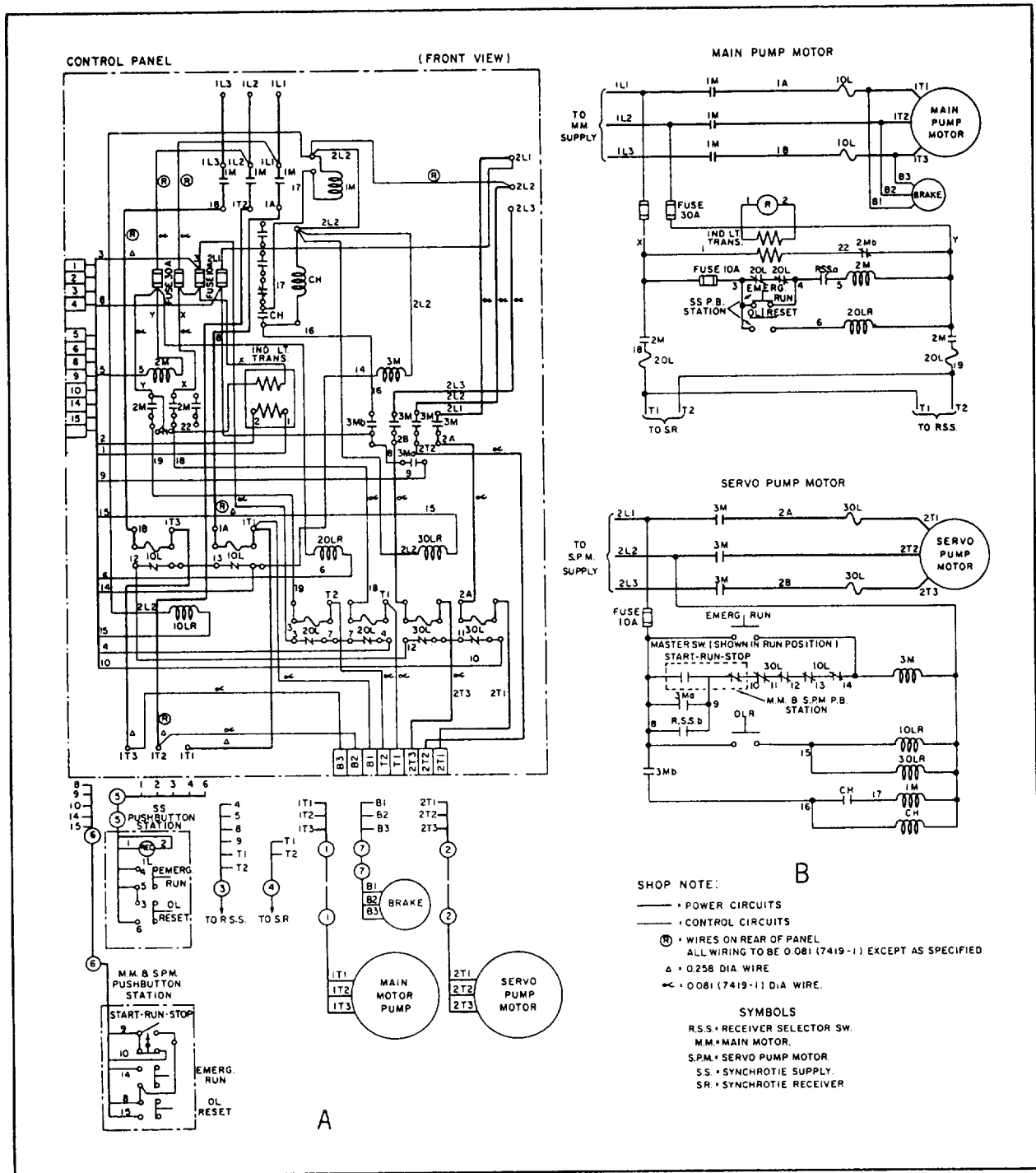


Figure 3-11.-Main motor controller: (A) Wiring diagram; (B) Schematic.

SCHEMATIC DIAGRAMS

The electrical schematic diagram is used to describe the electrical operation of a particular equipment, circuit, or system. It is not drawn to scale and usually does not show the relative positions of the various components. Parts and connections not essential to

understanding how the circuit operates are omitted for simplicity. Figure 3-11, view B, shows the schematic diagram for the steering system main motor controller.

ELECTRONIC PRINTS

Electronic prints are similar to electrical prints. However, they are usually more difficult to read than

electrical prints as they represent more complex circuitry and systems.

Shipboard electronic prints include isometric wiring diagrams that show the general location of electronic units and the interconnecting cable runs, and elementary wiring diagrams that show how each cable is connected. Also included among the common types of shipboard electronic prints are block diagrams, schematic diagrams, interconnection diagrams, electromechanical drawings, and logic diagrams.

The following paragraphs will discuss only those diagrams that were not discussed when we covered electrical prints.

INTERCONNECTION DIAGRAMS

Interconnection diagrams show the cabling between electronic units and how the units are interconnected. All terminal boards are assigned reference designations. Individual terminals on the terminal boards are assigned letters or numbers or both.

ELECTROMECHANICAL DRAWINGS

Electromechanical devices, such as synchros, gyros, accelerometers, and analog computing elements, are commonly used in IC equipment. For a complete understanding of these units, neither an electrical nor a mechanical drawing would be sufficient. Therefore, a combination type of drawing

called an electromechanical drawing is used. These drawings are usually simplified both electrically and mechanically, and only those items essential to the operation are indicated on the drawing.

LOGIC DIAGRAMS

Logic diagrams are used to show the operation of logic circuits in some IC equipment. They are used in the operation and maintenance of digital computers. Graphic symbols from American Standard Y32.14 are used.

Basic logic diagrams are used to show the operation of a particular unit or component. Basic logic symbols are shown in their proper relationship to show operation only in the most simplified form possible.

Detailed logic diagrams show all logic functions of the equipment concerned. In addition, they also include such information as socket locations, pin numbers, and test points to facilitate troubleshooting. The detailed logic diagram for a complete unit may consist of many separate sheets.

All input lines shown on each sheet of detailed logic diagrams are tagged to show the origin of the inputs. Likewise, all output lines are tagged to show destination. In addition, each logic function shown on the sheet is tagged to identify the function hardware and to show function location both on the diagram and within the equipment.

CHAPTER 4

MAINTENANCE

LEARNING OBJECTIVES

Upon completion of this chapter, you should be able to do the following:

1. Describe the different uses of schematics and drawings by IC Electricians when performing maintenance.
2. Describe the principles of testing, repairing, and replacing chassis wiring.
3. Recognize some of the fundamentals of preventive and corrective maintenance.
4. Identify the characteristics of amplifiers used in announcing systems, and discuss the principles of impedance matching.
5. Identify some of the fundamentals of modular assemblies and parts substitution in maintenance work.
6. Recognize some of the practices used to maintain and repair IC switchboards.

INTRODUCTION

Since IC Electricians are responsible for preventive and corrective maintenance of interior communications systems, they must be able to perform tasks such as repairing chassis wiring, matching speaker impedance, and servicing IC switchboards and associated equipment. This chapter describes general procedures for these tasks and for troubleshooting equipment in IC systems.

DRAWINGS AND SCHEMATICS

As a senior IC Electrician, you will use your ability to interpret schematics and drawings properly when accomplishing your maintenance tasks and when helping the less experienced personnel do the same. When working with these people, you will often need simplified versions of certain schematics and drawings.

Instruction books used by IC Electricians may contain diagrams of various types of schematic diagrams, block diagrams, wiring diagrams, interconnecting cable diagrams, mechanical drawings, and combinations of these. Diagrams are normally used for presenting information in a small space or for clarifying complex and detailed written explanations.

In chapter 3, we discussed various types of ship's drawings and diagrams and the procedures for verifying the accuracy of these drawings. The following

paragraphs will discuss the use of these drawings when you perform maintenance on IC equipment and systems.

SCHEMATICS

The diagrams IC Electricians use most often are the electrical and electronic schematics. From past experience, they should be familiar with the basic symbols, the building blocks of the schematics. There are new symbols for semiconductors, and future developments will undoubtedly bring more. *Graphic Symbols for Electrical and Electronic Diagrams*, USA Standard 432.16, has been adopted for mandatory use by the Department of Defense.

Wiring diagrams and equipment for integrated electronic systems are complex and require a knowledge of wire and cable identification markings and symbols that show the interconnection of units. Because of the increased use of computers and electronically controlled and mechanically operated automatic devices, the IC Electrician must recognize symbols and basic principles to interpret correctly mechanical drawings and electronic diagrams that show mechanical functions.

A complete schematic drawing of complex equipment may be too large for practical use. For this reason, most technical manuals present partial or simplified schematics for individual circuits or units.

As stated earlier in chapter 3, simplified schematics normally omit parts and connections that are not essential to understanding circuit operation. In studying or troubleshooting equipment, the technician often makes a simplified drawing, including only those items that contribute to the purpose of the drawing. When you are using the schematic drawings in this manual, technical manuals, textbooks, and other publications, notice the various techniques for simplifying schematics, thereby increasing their usefulness in maintenance work.

DRAWINGS

The drawings used by an IC Electrician include block diagrams, signal flow charts, wiring diagrams, and mechanical drawings. As with schematics, the IC Electrician will be familiar with some drawings from past experience. The use of block diagrams and signal flow charts to present the overall picture of equipment function is widespread. Although they do not contain the details that are needed in accomplishing maintenance tasks, they are obviously valuable in training situations and in providing overall continuity when personnel are working with partial schematics.

SYMBOLIC INTEGRATED MAINTENANCE MANUAL

The IC Electrician is responsible for maintaining many different types of complex electrical/electronics equipment. Usually, the diagnostic logic shortcomings of a young maintenance force result in longer than necessary equipment downtime. In some cases, equipment damage is introduced by trial-and-error maintenance actions. Some faults cannot be located and repaired by the unit level maintenance personnel because they lack experience or are not familiar with the equipment. Then too, personnel of all experience levels are frequently transferred and encounter new equipment. A relatively new troubleshooting aid, the *Symbolic Integrated Maintenance Manual (SIMM)*, should help the troubleshooter identify more readily the general location of a fault. Though this manual presents a rather complete circuit analysis, in no way does it prevent the requirement for local analysis and a well-informed technician. The SIMM represents a major change in the methods of presenting technical data and the methods of diagnosing electronic system faults. Through the use of new information display techniques and symbology, blocks, and color shading, the job of fault isolation in complex electronic systems is made easier, faster, and surer.

The overall objective of the *SIMM* is to display more descriptive and illustrative data per page; eliminate unnecessary words, discussion, and illustrations; organize all required data so rapid access is afforded, and display complete circuit element dependencies as simply as possible.

The *SIMM* helps organize the technical details of an equipment or system, providing users with all the information they need to learn to operate and maintain the equipment or system. The style of writing and the use of circuit-identifier codes (coding that assists recognition of the circuit character) and coded symbols enable the trainee to learn faster. Circuit diagrams and associated text are presented on facing pages.

The text is concise; yet it defines the circuit operation precisely. Block diagrams relate the level of physical containment (unit, assembly, subassembly, sub-subassembly) with the hardware to the functional circuits. Associated text is likewise presented on a facing page. Coded symbols and abbreviations indicate the kind of signals being processed, and circuit-identifier codes identify the circuit represented by uniquely shaped blocks. Maintenance dependency charts, based upon positive logic, provide a unique, fast method of trouble analysis, include operating procedures, and reveal to a degree the designed-in equipment maintainability. The emphasis on symbology, a concise writing style, and memory devices permit a reduction in page count with no loss in technical content.

The *SIMM* is developed around the following three basic building blocks:

- Blocked schematic
- Blocked text
- Precise-access blocked diagram

BLOCKED SCHEMATIC

By definition, a blocked schematic is a schematic diagram laid out in block form (fig. 4-1). It distinguishes the functions and physical aspects of the hardware by using shaded areas of blue and gray. The blue-shaded areas show the functional features of a circuit (lowest definable basic circuit, filter, voltage divider, oscillator, amplifier, relay contact, meter, coil, switch, and so on) and the gray-shaded areas show the hardware (chassis, drawer, module, and so on).

Each blue area includes ALL circuit elements that are involved in accomplishing the circuit function; these areas are called functional entities. Each functional

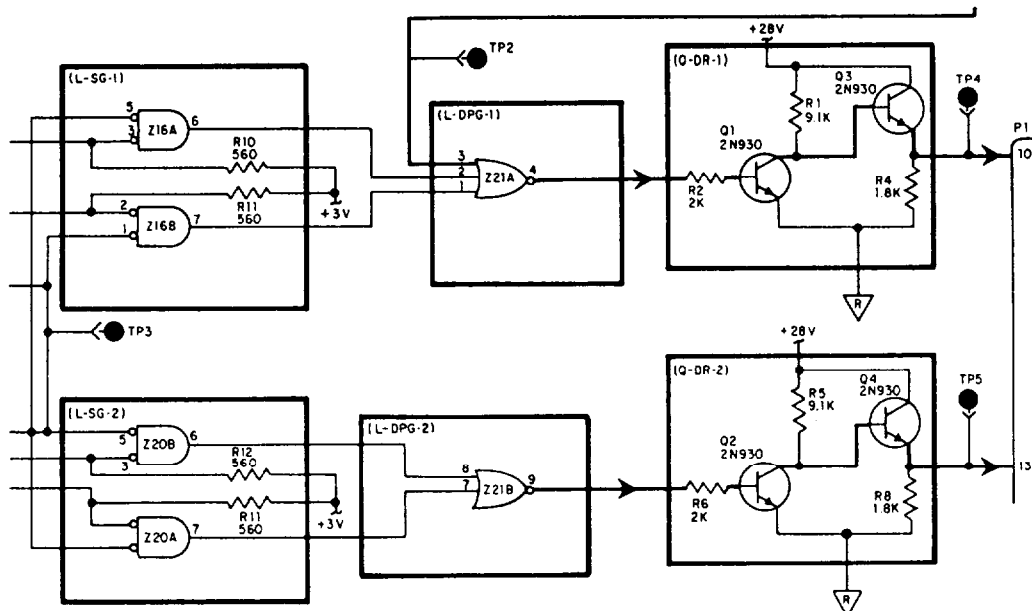


Figure 4-1.-Blocked schematic.

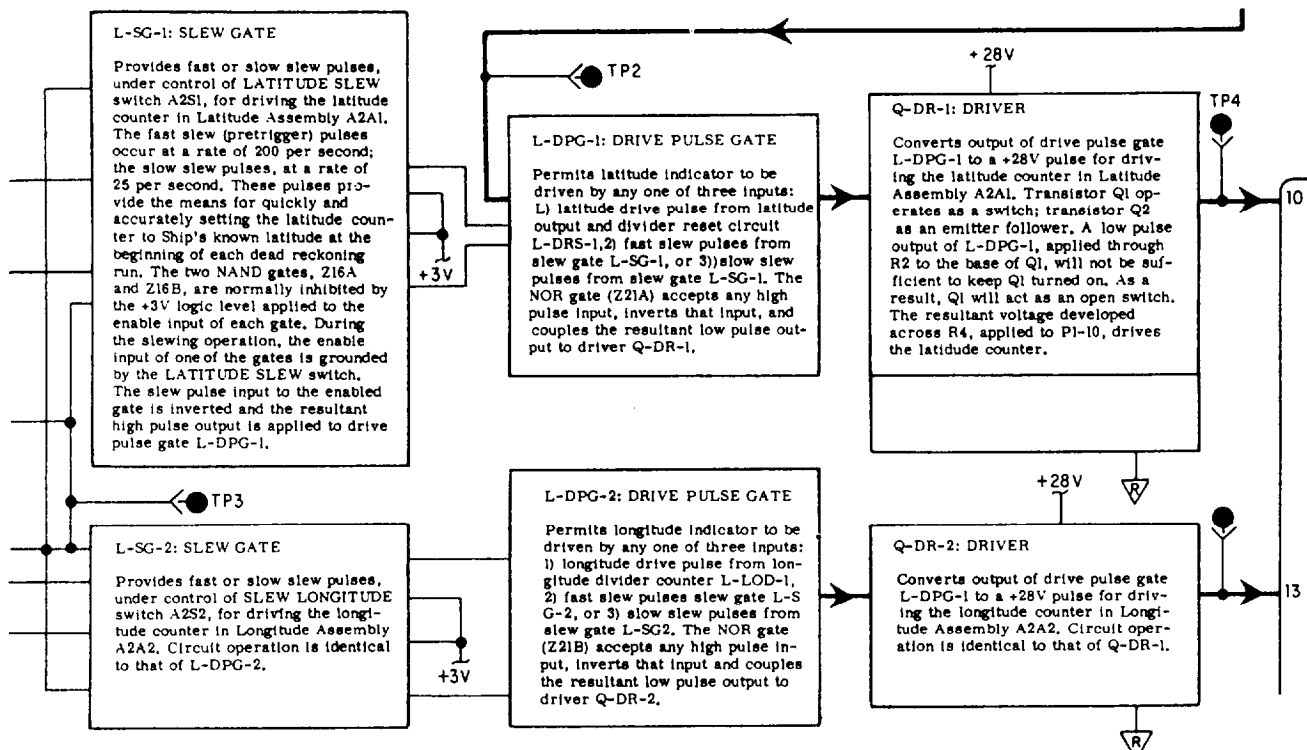


Figure 4-2.-Blocked text.

entity is easily and simply identified by a circuit-identifier code, such as Q-DR-1 or L-DPG-2. For example, in Q-DR-1 (a driver stage), Q is the active element (a transistor); DR is the abbreviation for driver; and 1 indicates the first occurrence of that type of functional entity in the assembly. Functional entities are connected by signal flow lines that show the kinds of

signals being processed by the coded shape of an arrowhead superimposed on the lines.

BLOCKED TEXT

The blocked text (fig. 4-2) is presented on a page facing the blocked schematic. The arrangement of the blocked text matches that of the blocked schematic.

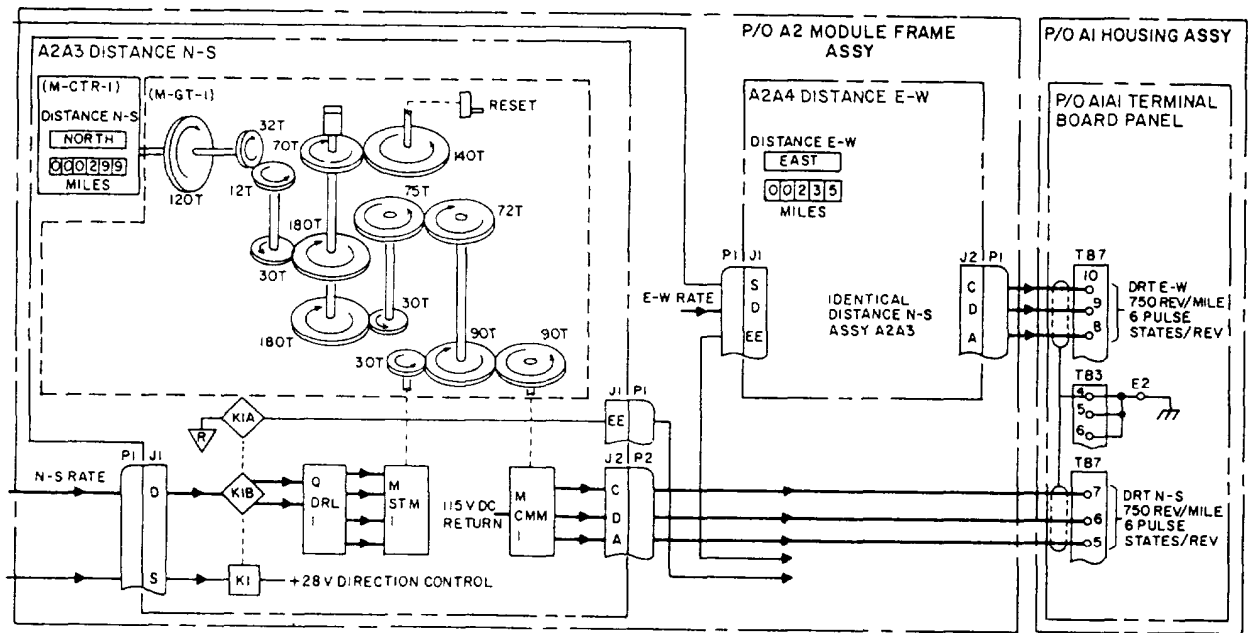


Figure 4-3. Precise-access blocked diagram.

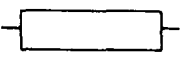
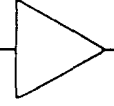
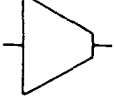

	INCLUDES ALL TYPES OF CIRCUIT ELEMENTS OTHER THAN THOSE SPECIFIED BELOW.
	CIRCUIT WHICH CHANGES THE VOLTAGE OR POWER LEVEL OF THE INCOMING SIGNAL. CIRCUIT MAY CONSIST OF AMPLIFIER STAGES, POWER AMPLIFIERS, EMITTER FOLLOWERS, ETC. THESE CIRCUITS ALWAYS CONTAIN ONE OR MORE NON-LINEAR ACTIVE ELEMENTS SUCH AS TRANSISTERS.
	CIRCUIT WHICH GENERATES A SIGNAL OR PROCESSES AN INCOMING SIGNAL IN SOME MANNER OTHER THAN TO CHANGE SIGNAL VOLTAGE OR POWER LEVEL. EXAMPLES ARE OSCILLATORS, CONSTANT CURRENT REGULATORS, ETC. THESE CIRCUITS ALWAYS CONTAIN ONE OR MORE NON-LINEAR ELEMENTS WHICH MAY BE ACTIVE (TRANSISTOR) OR PASSIVE (SEMICONDUCTOR DIODE).
	SWITCH

Figure 4-4. Functional circuit symbols used on precise-access block diagrams.

Notice that concise text, suitable to the component being described, replaces the circuit elements in the respective blue-shaded area. Paragraph numbers, references to illustrations, complete sentence structures, and formal grammatical rules are not necessary to impart all needed information. The use of facing pages, similar block arrangements of text and components being described, enables a rapid association between text and blocks, text and circuit detail, and circuit detail and blocks. Like the blocked schematic, each blue-shaded area includes a circuit-identifier code for identification of the components being described. The greatest value of this

code is realized on high-level diagrams where much information must be confined to a small space.

PRECISE-ACCESS BLOCKED DIAGRAM

A precise-access blocked diagram is the next higher level diagram (fig. 4-3). It emphasizes levels of physical containment (units, assemblies, and so on) of the components with respect to their enclosures. Four basic shapes are used as symbols on this diagram to show the kind of circuit through which the signal is being processed. These symbols are shown in figure 4-4.

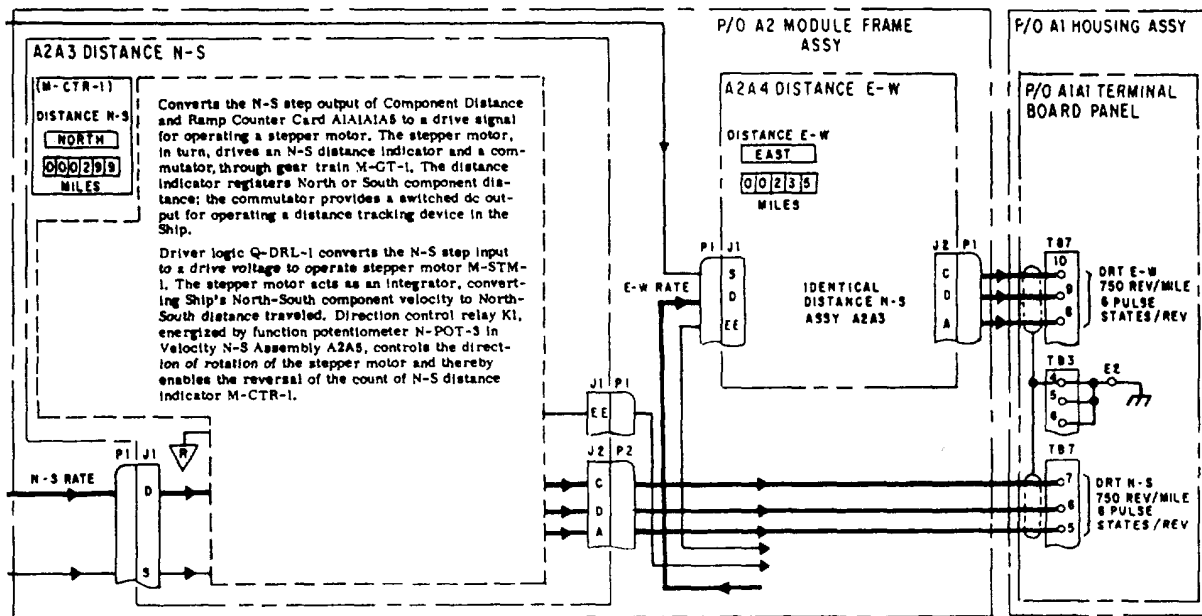


Figure 4-5. Precise-access blocked text.

In each basic shape is inscribed the circuit-identifier code that identifies the actual component. In addition, the coded arrows superimposed on the signal-flow lines that tie these shapes together are again used to identify the signals being processed. Also superimposed over these block diagrams are shades of gray that indicate the level of containment of the components or other circuit elements in the equipment through which the signal or signals pass. Again there is blocked text on the facing page (fig. 4-5).

Detailed cabling information between all assemblies is shown on the precise-access blocked diagram. In cases of large complex equipment, however, power circuit cabling is detailed on power distribution diagrams.

OPERATING PROCEDURES

Procedures that explain how to operate equipment under normal and emergency conditions are included in the operating procedures. Manuals for some equipment contain an operating chart that establishes a turn-on and checkout procedure. The chart displays chronologically all indications that can be recognized from outside the equipment. The indications are events, such as meter readings, lights, synchro rotating, or motor running noise, that can be recognized by the human senses. Shaded bands stretching across the chart show the time lapse between events. All simultaneous events for a given step of the procedure appear on one horizontal

line. Monitors are indicated in a solid black background box with white lettering.

Front panel indicators and other recognizable indications with front panel markings, as applicable, and their associated cabinet nomenclature are located along the top of the chart. If an event fails to happen, fault isolation is simplified by the indexing on the operator's chart. This indexing will lead the troubleshooter to the proper maintenance dependency chart and the circuit chain upon which the missing event depends. The troubleshooter merely associates the operational step and the event that did not occur to find the pertinent circuit chain. A vertical column on the left side of the page contains the turn-on procedure in a sequence of steps consistent with the engineering designed plan of turn-on. Also in the left-hand column, boxed and indented, are checkout procedural steps that can be performed at any time during operation. These checkout steps will give an indication of the functional performance and will provide a sound basis for selection of operator, preventive-maintenance checks.

MAINTENANCE DEPENDENCY CHART

One of the most important features of the *SIMM* is its troubleshooting tool, the maintenance dependency chart (MDC). In addition to front panel marked indicators displayed across the top of the page, it contains the various assemblies or circuit elements through which a signal passes, as well as their chassis

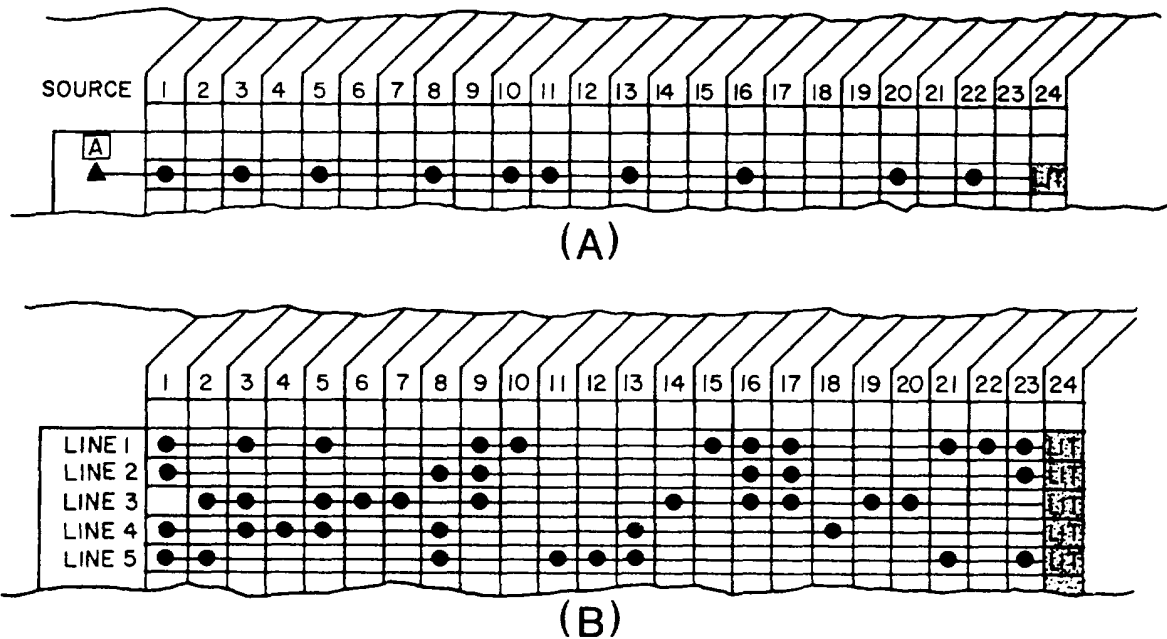


Figure 4-6.-Maintenance dependency charts: (A) Single event line showing dependency marker; (B) Multiple event lines showing parallel and unique functional items.

or cabinet locations. Each horizontal line results in an action, such as a lamp lighting, a synchro rotating, a meter indicating, or an indication of signal availability. These actions are called events. Each horizontal line (event line) is a representation of the circuit that develops the event on its line. The MDC has the unique advantage of permitting the simple display of many events and their relationships in a limited space.

The technique of isolating a fault is based upon a positive approach. It is an analysis of circuitry to verify whether the things that should have happened did happen. The event, if normal, is either readily observable or its signal can be measured. If either the action or signal is not present, components or circuits upon which the event is dependent can be readily ascertained. With other methods of troubleshooting, it was impractical to present all the combinations that could cause a malfunction; for example, a trouble in 1 of 43 events resulting from parallel actions could represent approximately one trillion possible symptoms. Accordingly, the negative approach to fault isolation or the so-called symptom-probable-cause-remedy method is inadequate for the complexities that often occur in electronic circuits.

MDCs, often more detailed and involved than the samples shown in figure 4-6, views A and B, are required to represent the complex circuitry of modern electronics systems. To help you understand an MDC, the

definitions of its key terms and symbols are given in the following sections:

EVENT—An action or an availability of a signal at a point in a circuit. The event may be characterized as motor running, temperature normal, lamps lit, lamps out, instruments indicating, signal or voltage available or not available, relay solenoids or thrusters energized, and so on.

FUNCTIONAL ENTITY—A group of circuit elements that together form a basic functional circuit, such as a filter network, a voltage divider network, an amplifier stage, an oscillator stage, and a flip-flop stage,

CIRCUIT ELEMENT—An individual piece or part for which no further breakdown can be made insofar as fault isolation is concerned. Relay or switch contacts, relay coils, resistors, capacitors, motors, and fuses are examples; printed-circuit boards are not.

DEPENDENCY MARKER—The solid black triangle (▲) is used as a dependency marker. On an event line, it shows that an action or availability of a signal occurring on its line is dependent upon the occurrence of an action or availability of a signal directly above its apex. The signal or action above the dependency marker must be available and within specification for the event on the line of the dependency marker to result, if all the circuits and parts symbolically represented along the line are also performing properly.

A solid black rectangle and white lettering represent a front panel indicator or an event recognizable from outside the cabinetry; an outlined rectangle with black lettering is a circuit point at which measurement might at some time be made. This circuit point may not be readily accessible. Internal test points that are readily accessible will be shown as gray-shaded rectangles.

The dot (·) represents a circuit element or a functional entity. One aspect or state of circuit or component is represented by (·), and relay contacts are shown by (/·) or (·/), for continuity with relay energized or de-energized, respectively.

HOW TO USE THE MAINTENANCE DEPENDENCY CHART

Assume that in the illustration of a signal event line, figure 4-6, view A, dots (·) represent the basic circuits (oscillator stages, amplifier stages, and soon) or circuit elements (relay contacts, relay cards, and so on) that provide an action LIT at the end of a circuit chain (event line). The solid triangle (▲) is a dependency marker.

The action LIT depends on the availability of a power source at the A block and on the proper operation of each of the circuits or circuit elements (·) represented along the event line. Now, if the lamp that indicates the action fails to light, any item along the event line, as well as the source, A, is a suspect item. Complex interrelated circuits often use some of the same circuits or circuit elements for more than one purpose. Thus, in multiple circuits, where many functional items are common to more than one circuit chain (event line), as shown in figure 4-6, view B, notice that actions (column 24) that occur at the end of these circuit chains are a result of certain common items employed in the parallel generation of the events shown on other circuit lines and some items that are unique to a single line.

Look again at the multiple event line illustration (fig. 4-6, view B) for the purpose of analysis. If the lamp does not light on line 4 but does light on lines 1, 2, 3, and 5, it becomes apparent that the circuits or circuit elements represented by the dots in columns 4 and 18 are the only ones that can be suspected as faulty. All items represented by dots in other columns are proven good because of the proper occurrence of the action LIT on lines 1, 2, 3, and 5.

For each major circuit, consistent with the precise-access blocked diagrams and blocked schematics, there is a corresponding MDC. Troubleshooting is accomplished by analyzing the

charts. Faults must lie between the first bad event and the last good event. Acetate coverings for MDCs may be provided, or the charts maybe plasticized, so a grease or carbon pencil can be used for marking out areas that prove good. Marking out all known areas and actions that can be proven good rapidly reveals suspect areas. The use of a pencil to mark out all proven good items is recommended because technicians cannot normally remember all the areas or dependencies that they have proven good.

INDEXING OF RELATED INFORMATION

Indexing is another important feature of the *SIMM*. The *SIMM* method of indexing (fig. 4-7) allows access to any bit of information relative to an assembly in a matter of seconds. The index is organized on the basis of major assemblies and then is broken down to the contained assemblies. Since each of the assemblies is fully treated within a four- or six-page data package, and the organization of details is always consistent, access to the desired kind of detail is almost immediate. The MDC is used to identify the functional entity or circuit element that is suspected, the assembly in which it is contained, and the cabinet containing the assembly. Accordingly, in using the index you need only find the cabinet nomenclature and look to the page number for the contained assembly data package.

ALIGNMENT PROCEDURES

Alignment procedures for each functional section of the set or system, as necessary, are included on as few pages as possible. The method of identifying alignment procedures is the same as for making other identifications from the MDC. The alignment procedures are directly keyed from the signal specifications listed on the MDC. If a particular event shown on the MDC is below specification and correctable by alignment, the step in the alignment chart is easy to find. Each part of the MDC treats a major functional segment of equipment. Likewise, the alignment actions are organized (charted) for each major fictional segment of the equipment. The identification system for the charts is used for the alignment procedure chart. For example, alignments that affect events on the MDC, part 2, will be found on the alignment chart, part 2, and so on. When required, alignment of subassemblies outside the set environment will be contained with the other details of individual assemblies in the data package for the assembly.

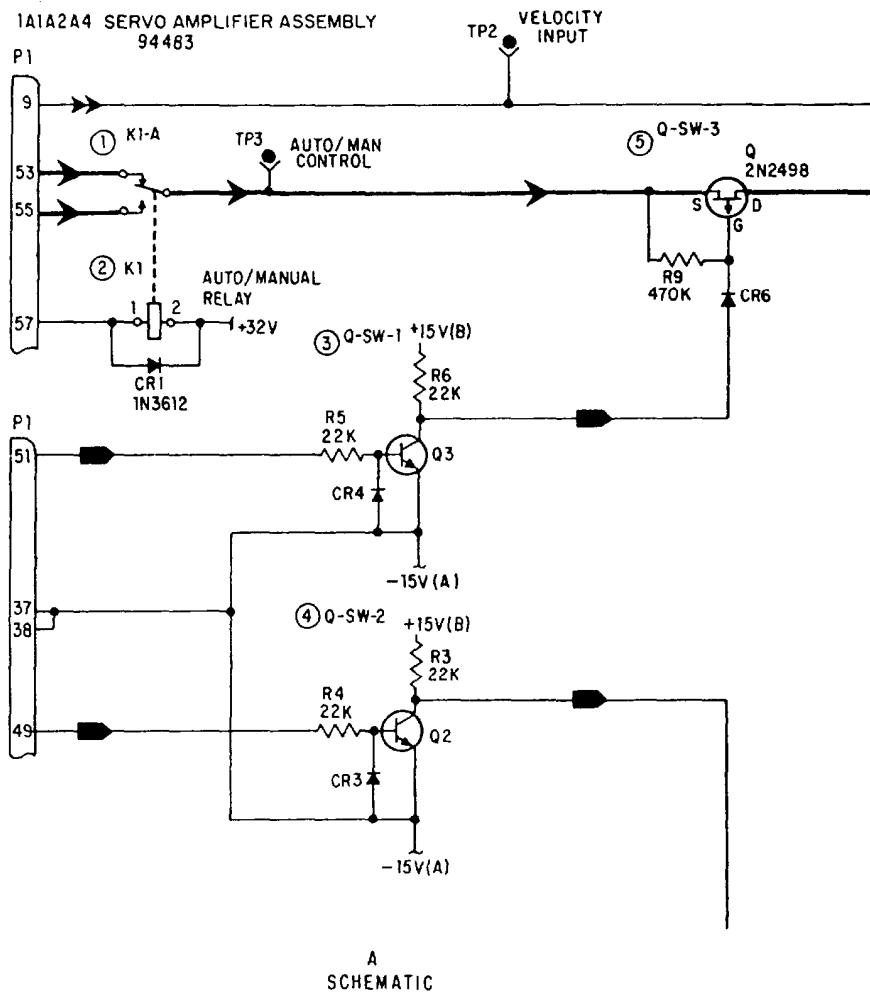
EXPLANATION OF CIRCUIT IDENTIFIER CODES

CATEGORY	DEFINITION
C	Composite circuit (one which is subfunctionalized): composite functional entities containing one or more of the functional entities (L, Q, X, N, M) given in this list are preceded by C.
L	Logic circuits.
Q	Circuits containing one or more nonlinear elements which may be either active or passive: functional entities containing transistors are preceded by Q.
X	Circuits containing one or more nonlinear elements which may be either active or passive: functional entities containing semiconductor diodes are preceded by X.
N	Linear networks: functional entities containing several linear components (resistor, capacitors, etc.) arranged in a network or containing a single element used as a network are preceded by N.
M	Circuits containing mechanical devices such as gears, clutches, cams, mechanical stops, etc. are preceded by M.

EQUIPMENT DATA

SUBJECT	PAGE(S)
Symbols/Shading/Logic Devices	3
Foreword	4
Equipment Description	5 - 6
Installation Data	7 - 8
Electrical Connections	7
Post-Installation Procedures	8
Operating Procedures	9 - 10
Weekly Operation Check	10
Preventive Maintenance Procedures	11
Equipment Accuracy Check	11
Operator's Checks and Adjustments	11
Operator Maintenance	11
Calibration/Alignment Procedures	12 - 13
Performance Check Chart	14 - 22
Power Distribution Function	14 - 15
OSS/Heading Function	15 - 16
Velocity/Distance Function	16 - 18
Latitude/Longitude Function	18 - 19
Comparator Card	19 - 20
Component Distance and Ramp Counter Card	20 - 21
Total Distance and Calibration Card	21
Divider Counter Card	21 - 22
Coincidence Card	22

Figure 4-7. Functional index and explanation of codes.



IA1A2A4 SERVO AMPLIFIER ASSEMBLY

COMPARES EITHER THE ANALOG DEPTH SIGNAL OR THE MANUAL DEPTH SIGNAL WITH THE ERROR VOLTAGE FEEDBACK. IF THERE IS ANY DIFFERENCE BETWEEN THESE TWO SIGNALS, A DIFFERENCE SIGNAL IS GENERATED, AMPLIFIED AND USED TO DRIVE THE SERVO MOTOR.

① K1A1-A

ENERGIZED: CONNECTS ANALOG DEPTH SIGNAL TO Q-SW-3. DE-ENERGIZED: CONNECTS MANUAL DEPTH SIGNAL TO Q-SW-3.

② K1

ENERGIZED WHEN THE MANUAL MODE IS SELECTED.

③ Q-SW-1 SWITCH

CONDUCTS FOR ONE HALF CYCLE OF THE INPUT CHOPPER REFERENCE. TURNED ON AND OFF AT A 400HZ RATE. CR4 PROTECTS Q3 FROM EXCESSIVE BASE TO EMITTER REVERSE VOLTAGE. CONDUCTION IS 180° OUT OF PHASE WITH CONDUCTION OF Q-SW-2. WHEN Q-SW-1 IS CUT OFF +15 VOLTS IS APPLIED TO THE GATE OF Q4, CUTTING OFF Q-SW-3.

④ Q-SW-2 SWITCH

OPERATION IDENTICAL TO Q-SW-1 EXCEPT CONDUCTS ON THE ALTERNATE HALF CYCLE OF THE CHOPPER REFERENCE.

⑤ Q-SW-3 SWITCH

TURNED ON AND OFF AT A 400HZ RATE BY THE OUTPUT OF Q-SW-1. SINCE POSITIVE VOLTAGE AT THE GATE WILL CUT OFF Q-SW-3, Q-SW-1 WILL BE TURNED ON AND OFF AT A 400HZ RATE. THUS, THE DEPTH VOLTAGE IS APPLIED TO C3 AT A 400HZ RATE.

A
SCHEMATIC

B
TEXT

Figure 4-8.-SIMM keyed text.

PARTS LOCATION AND IDENTIFICATION

Equipment and assembly halftones and line drawings are overlaid with a blue-colored grid on which coordinates are placed to assist in parts location. Associated with the parts-location illustration is a cross-reference table identifying the items by reference designations, their coordinate positions, and significant military-type numbers or manufacture' part numbers.

REPAIR OF MECHANICAL ASSEMBLY

Mechanical assemblies, gear trains, and so on, are illustrated to the extent necessary to assure sufficient data for repair. When assemblies are illustrated in exploded form, index numbers are cross-referenced to contractors' drawing numbers or to contractors' vendors' part numbers. Subassemblies, such as synchro motors, that frequently are identified by nonreadily translatable military-type numbers also include

sufficient meaningful data for ordering purposes. When complex assembly and disassembly procedures are involved but not obvious, detailed procedures are given. Exploded views on the same or facing pages will describe and illustrate these procedures.

IMPROVEMENTS

Compared to the already described *SIMM*, newer editions of the manual will show improvements in method of presentation, use of MDC, and size.

Instead of the blocked text, the improved manuals use a keyed text method of presentation in which the text material is arranged in tabular format and keyed to the diagram by circled numbers, as shown by figure 4-8. This method permits significantly more text material to be presented than the blocked text method. Besides being used with the schematic diagrams, the keyed text is also used with the precise-access block diagrams

(called functional block diagrams) and the overall block diagrams (called the function description diagrams).

Instead of only one MDC for each major function, newer manuals will have additional MDCs for the functional block and schematic diagrams. The MDCs also will be provided with an acetate or Mylar overlay so troubleshooters can use grease pencils to mark their progress. The size of the new *SIMM* will be 11 by 27 inches, instead of 15 by 35 inches. This new size gives it a folded dimension of 9 by 11 inches, the same size as conventional manuals.

CHASSIS WIRING

Chassis wiring is loosely defined as the wire or wires installed in an equipment cabinet that interconnect the assemblies of the cabinet. Chassis wiring varies in application and size of run. It may range from a harness or run of two wires, used in sound-powered amplifiers and telephone cases, to large cable runs, such as those in MC cabinets, dial telephone switchboards, and gyro binnacles. IC Electricians must be able to test, repair, and replace chassis wiring, regardless of its run size and application.

TESTING CHASSIS WIRING

In testing chassis wiring, it is not possible to substitute for good common sense. Your first step in testing chassis wiring of a faulty piece of equipment should always be a detailed visual inspection of the wiring harness, from terminal to terminal. A complete visual check will save you many hours of work looking for trouble that you could have detected in the first place by inspecting the equipment for visible damage. If certain wires are obviously at fault, you should replace them before going any further in the test.

Your sense of smell can help in pinpointing burned or damaged wire that you may not see when making the visual inspection. Most burned electrical insulation will give off a noticeable, unpleasant odor that is readily detectable. The location of a burned wire, however, does not necessarily reveal the cause of the trouble.

Signal tracing is the most reliable method of locating shorts, opens, or grounds in chassis wiring. The best method of making continuity tests for shorts and grounds in chassis wiring calls for the use of a multimeter and manufacturers' instruction books.

REPAIRING CHASSIS WIRING

A major consideration in repairing chassis wiring is the amount of time you have to complete the repair and get the equipment back in operation. If the equipment is to be "down" for a long time, be sure the repair is completed correctly. As a temporary repair, it is permissible to run a straight wire instead of following the original cable run. This temporary lead should be soldered in place, after you disconnect the faulty lead. This practice should only be done when there is insufficient time to make the proper repairs.

When a few wires are to be replaced, lace them to the outside of the existing cable run. When many wires are to be replaced, remove the damaged wiring and re-run the new wires along the route of the old cable run. After connecting the wires, you should lace or clamp them in their original positions.

You should avoid unnecessary slack in the cable runs and always try to keep your repairs neat and workmanlike. A properly replaced wire or cable run also will make it easier to trace later.

REPLACING CHASSIS WIRING

Sometimes your personnel may have to replace chassis wiring in components of IC systems, such as 21MC units. Chassis wiring is usually the last part to fail in electronic equipment, but it can wear out from minor friction and abrasion in the course of making other repairs, or it can be damaged by a malfunction that causes overheating or fire.

Individual leads in chassis wiring must be replaced wire for wire. This is a tedious job, but one that requires only skill with a soldering iron. A wiring harness containing damaged wires is best repaired by replacing it with a prefabricated harness. Prefabricating a replacement harness is usually easier than repairing individual wires in the old harness. An installed harness is hard to work on, and soldering on it may damage other wiring insulation or electronic components. If the unit to be repaired is still in working order, the replacement harness can be made, and then installed whenever it is convenient to have the unit off the line.

The first step in making a wiring harness is to make a wiring form or jig, as shown in figure 4-9. Build the form on a sheet of 1/4-inch plywood, using small (6d) finishing nails. Using a plastic ruler, measure the original harness and chassis in the unit to be repaired. Your measurements should let you outline the chassis and the location of the harness run and mark the

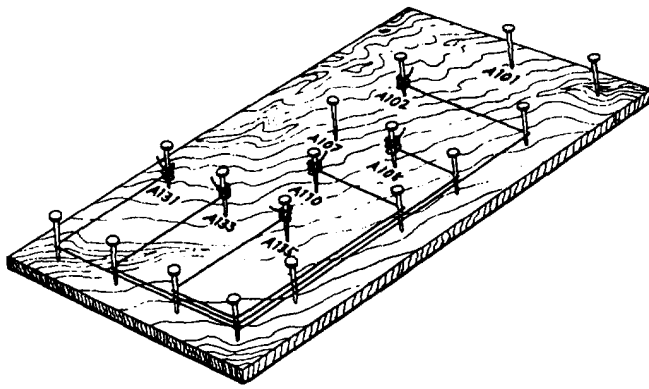


Figure 4-9.-Harness form.

positions of the terminals on the board. Drive nails at each terminal location and at points where the wires and harness bend. Write the terminal designations near the appropriate nails, using the wiring diagram from the equipment manual to double-check that terminal markings are correct. When this is done, you can return the unit to service until it is convenient to install the new harness.

The wires are run between the terminal points, following the route outlined by the nails. Do not stretch the wires tight. The bitter ends of each wire are wrapped around the nails located at its terminal positions. When all terminals have been connected, the harness is formed and can be laced. If terminal connectors are to be used, they are soldered in place after lacing is complete, and spaghetti put in place.

When the new harness is ready, you can install it in a relatively short time. If it is to replace a harness in equipment that is operating, the installation can be postponed until the ship is in port or the unit is not needed.

When installing or replacing wire or cable runs in equipment cabinets, make sure the slack between cable clamps is not excessive. Normally, wire should not sag by more than one-half of an inch when normal hand pressure is applied. Allow enough slack at each end to prevent strain on the wire and to permit removal and connection of plugs, replacement of terminal lugs, and free movement of shock and vibration-mounted equipment.

Bends in individual wires should not exceed a radius of 10 times the diameter of the wire or group of wires except where the wire is suitably supported at each end of the bend; the minimum bend radius is 3 times the diameter of the wire.

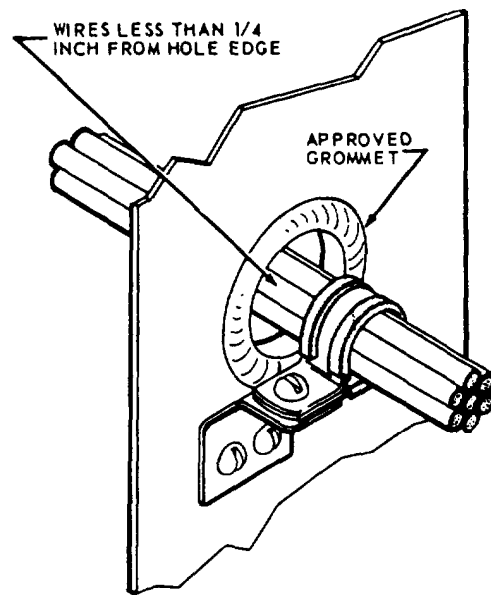


Figure 4-10.-Cable clamp and grommet.

Wires passing through partitions or supports inside a chassis must be supported at each hole by a cable clamp or other permanent support. If the clearance between the edge of the hole and the cable exterior is less than one-fourth of an inch, install a suitable grommet in the hole (fig. 4-10).

PREVENTIVE MAINTENANCE

The best maintenance is preventive, as potential failures are detected and not given a chance to develop. Preventive maintenance is defined as the measures taken periodically, or when needed, to achieve maximum efficiency in performance, to ensure continuity of service, and to lengthen the useful life of the equipment or system. This form of maintenance consists principally of cleaning, lubrication, and periodic inspections aimed at discovering conditions that, if not corrected, may lead to malfunctions requiring major repair.

EQUIPMENT INSPECTIONS

Equipment inspections fall into two main categories. First, there is the regular visual inspection of the mechanical aspects of the equipment. This inspection is conducted to find dirt, corrosion, loose connections, mechanical defects, and other sources of trouble. Second, there are functional inspections that are accomplished by periodic testing and less frequent bench testing. To realize the most effective results from

functional inspections, you should keep a careful record of the performance data on each piece of equipment.

PERFORMANCE DATA RECORDS

Locally prepared performance data records are valuable in several ways. By comparing data taken on a particular piece of equipment at different times, you can detect slow, progressive drifts that may not show in any one test. Though week-to-week changes may be slight, you should follow them carefully so necessary replacement or repair can be made before the lower limit of performance is reached. Any marked variation is abnormal, and it should be investigated immediately. Also, by keeping systematic records of performance and servicing data, maintenance personnel become acquainted with the equipment faster. Then too, the accumulated experience contained in the records furnishes a guide to swift and accurate troubleshooting.

Most of the actual work of organizing and implementing a system of testing and servicing of equipment is outlined in the 3-M Systems. However, testing and recordskeeping can apply to maintenance-related functions not covered by the 3-M Systems.

CORRECTIVE MAINTENANCE

Corrective maintenance consists of locating and correcting troubles in equipment or a system that fails to function properly. Location of troubles includes evaluation of equipment performance and troubleshooting.

EVALUATING PERFORMANCE

The manufacturer's instruction book for each particular piece of electrical/electronic equipment contains performance standards that enable the technician to make an intelligent evaluation of the operating capabilities and efficiency of the equipment. The standards are designed to make sure the equipment operates at maximum efficiency at all times; any reduction in performance indicates the need for corrective action. These instruction books also give the technician step-by-step performance checks, indicating clearly all the test connections and test equipment for each step.

When a discrepancy is brought to your attention through an operator's trouble call or as a result of an PMS check, you should first determine whether the equipment is faulty or not. It is a mistake to remove the

equipment from operation before checking it thoroughly, unless you suspect a malfunction that could cause further damage to the equipment.

IC Electricians should have a prescribed procedure to check a discrepancy or trouble call. You may find the following approach helpful in evaluating operating discrepancies.

- **Visual in-place inspection**—This inspection may disclose frayed or broken wiring and loose electrical or mechanical connections.

- **Operational check**—This check may pinpoint the trouble to a particular unit. In some cases, it may disclose the use of improper operating procedures, especially with new equipment by inexperienced personnel.

- **Performance test**—This test is an extension of the operational check and is conducted with portable test equipment and built-in meters; it can help localize the source of the trouble.

IC Electricians should conduct a quality control inspection of all overhauled or repaired equipment before it is reinstalled. This inspection combines the visual inspection, operational check, and performance test to assure the equipment is in proper operating condition and ready for use.

TROUBLESHOOTING

Corrective maintenance usually is concerned with the process of troubleshooting. There are several ways to describe troubleshooting. One description is as follows: several steps through which a technician gains information about a casualty, isolates and repairs the faulty component, and clearly understands the reason for the malfunction.

When the presence of a malfunction has been recognized, the first phase of troubleshooting has begun. The operation of the system is analyzed to determine which area of the equipment is causing the trouble.

When faulty operation of a piece of equipment has been traced to a particular stage or group of stages, the next phase of troubleshooting is begun—identifying, isolating, and repairing the faulty component or group of components.

To prevent the reoccurrence of the malfunction, you must clearly understand the reason the malfunction occurred so all faulty components can be replaced; not just the most obvious ones.

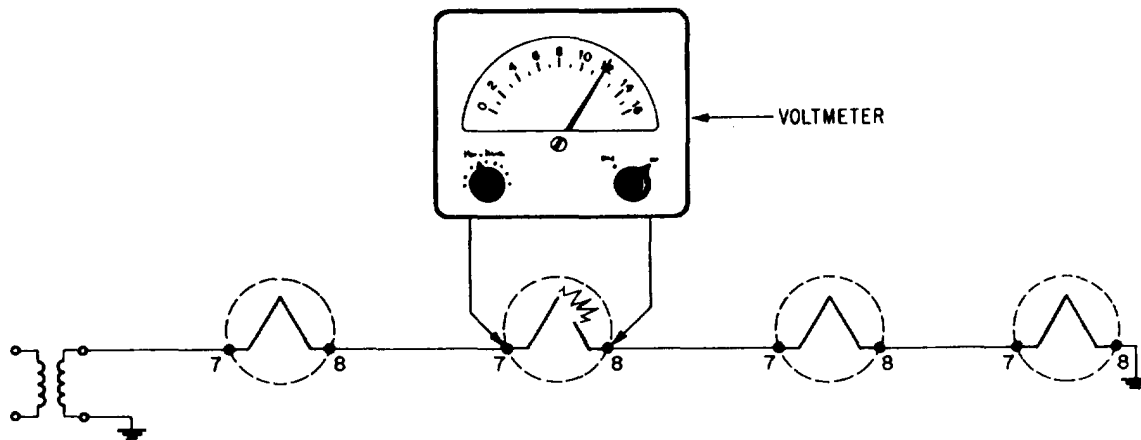


Figure 4-11.-Voltage check.

As a supervisor, you should make sure detailed trouble isolation procedures are performed according to the instruction manual for the equipment being repaired.

TESTING TUBES

Electron-tube failure accounts for most of the trouble in systems using tubes. It is impractical to try to locate faults by general tube checking. Only when the fault has been traced to a particular stage should tubes be tested. Then, only those tubes associated with the improperly functioning circuits should be tested.

MEASURING VOLTAGE

Since most troubles in equipment and systems result from, or produce, abnormal voltages, voltage measurements are considered indispensable in locating troubles. Testing techniques that use voltage measurements have the disadvantage of requiring work on an energized circuit. Point-to-point voltage measurement charts that show the normal operating voltages in the various stages of the equipment are available to the troubleshooter.

When voltage measurements are initially taken, it is good practice to set the voltmeter on the highest range so any excessive voltage in a circuit will not damage the meter. To obtain increased accuracy, the voltmeter may then be set to the range for the proper comparison with the values given in the voltage charts.

If the internal resistance of the voltmeter and multiplier is approximately the same in value to the resistance of the circuit under test, it will indicate a lower voltage than the actual voltage present when the meter is removed from the circuit. The sensitivity (in

ohms-per-volt) of the voltmeter used to prepare the voltage chart is always given on the charts. Therefore, if a meter of an approximately equal sensitivity is available, use it so the effects of loading will not have to be considered.

When you are checking voltages, you should remember that a voltage reading can be obtained across a resistance, even if the resistance is open. The resistance of the meter and the multipliers form a circuit resistance when the meter prods are placed across the open resistance (fig. 4-11).

MEASURING RESISTANCE

Defective components can usually be located by measuring the dc resistance between various points in the circuit and a reference point or points (usually ground). This is true because a fault will generally produce a change in resistance values. Point-to-point resistance charts can be used advantageously when you make resistance measurements. The values given, unless otherwise stated, are measured between the indicated points and ground.

Before making resistance measurements, the IC Electrician should make sure the power to the equipment under test has been turned off. Since an ohmmeter is essentially a low-range voltmeter and a battery, an ohmmeter connected to a circuit that already has voltages in it may be seriously harmed. The pointer may be deflected off-scale, and the meter movement maybe permanently damaged.

Filter capacitors must be discharged with a shorting probe before making resistance measurements. This is extremely important when you are testing power supplies that are disconnected from their loads. If a capacitor discharges through the meter, the surge may

burn out the meter movement. Furthermore, contact with a circuit containing a charged capacitor will endanger the life of the person making the test.

COMPARING WAVEFORMS

The measurement and comparison of waveforms are considered to be very important parts of the circuit analysis used in troubleshooting. In some circuits (for example, pulse circuits), waveform analysis is indispensable. Waveforms may be observed at test points, shown in the waveform charts that are part of the maintenance literature for the equipment. You should note that the waveforms given in the instruction books are often idealized and do not show some of the details that are normally present when the actual waveform is displayed on an oscilloscope.

By comparing the observed waveform with the reference waveform, faults can be localized rapidly. A departure from the normal waveform indicates a fault that is located between the point where the waveform is last seen to be normal and the point where it is observed to be abnormal. (For example, if a waveform is observed to be normal at the grid circuit and abnormal at the plate circuit of the same stage, this indicates that the trouble lies in that stage or possibly the input of the following stage.)

If there is no trouble present in an equipment or system, a waveform observed at a point in the equipment should closely resemble the reference waveform given for that test point. The reference waveforms supplied with maintenance literature are the criteria of proper equipment performance. However, test equipment characteristics of usage can cause distortion of the observed waveform, though the equipment or system is operating normally. Several of the most common causes of these conditions are summarized in the following sections:

- The leads of the test oscilloscope may not be placed in the same manner as those preparing the reference waveforms, or the lead lengths may differ considerably. This is particularly significant in shielded test leads, where the capacitance per unit length is a factor.
- A type of test oscilloscope having different values of input impedance, different sweep durations, or different frequency response may have been used.
- The equipment operating (and servicing) controls may not have settings identical to those used when the reference waveforms were prepared. This

condition is normally to be expected when servicing adjustments are made in terms of their effect on the shape and amplitude of an observed waveform.

- The vertical or horizontal amplitudes of the reference and test patterns may not be proportional. This will produce apparent differences between the waveforms when actually there is no difference.

Whether or not a minor waveform discrepancy may be disregarded depends upon the type of circuit being traced. A minor discrepancy is not regarded as significant unless the nature of the discrepancy indicates faulty operation of the equipment. In general, time should not be wasted in searching for faults when relatively minor differences are detected between the reference waveforms and those obtained by test.

AMPLIFIERS IN ANNOUNCING SYSTEMS

In purchasing a public address system, where you already know its power requirements, locations and types of microphones, and number and types of speakers, you may have to decide between a system that uses vacuum-tube amplifiers or one that uses transistor amplifiers. Your decision should be based on factors other than relative costs. Here are some reasons for the use of transistor amplifiers instead of vacuum-tube amplifiers:

- The life of a transistor is longer than that of a vacuum tube.
- Transistors consume less power than vacuum tubes.
- Transistor amplifiers use dc power more efficiently than vacuum-tube amplifiers.
- Transistors operate more efficiently at low voltages than vacuum tubes.
- Microphonics signals generated by shock or vibrations are almost completely lacking in transistors.
- Power is instantly available at the throw of a switch.
- Ac hum is minimized.

On the other hand, vacuum-tube amplifiers offer these advantages over transistor amplifiers:

- Vacuum-tube replacements take less time than transistor replacements.
- Vacuum-tube amplifiers are less likely to be affected by high ambient temperatures or to suffer heat damage.

- Vacuum-tube amplifiers are easier to service on the bench.

IMPEDANCE MATCHING IN AMPLIFIERS

Amplifiers must sufficiently amplify an input signal to the point where it may be applied to a power amplifier. Due to their high input impedance, electron tubes cause few impedance matching problems. While the input impedance for transistors may be high in some configurations, transistor circuits are nevertheless more troublesome in this respect. A more detailed discussion will now be given on how the effects of the input impedance determine the choice of transistor configurations.

The most desirable method of matching source impedance to input impedance is by transformer coupling; however, this is not always practical. When the preamplifier must be fed from a low-resistance source (20 to 1,500 ohms), without the benefit of transformer coupling, either the common base (CB) or the common emitter (CE) configuration may be used. The CB configuration has an input impedance that is normally between 30 and 150 ohms; the CE configuration has an input impedance that is normally between 500 and 1,500 ohms.

If the signal source has a high internal impedance, a high input impedance can then be obtained by using one of the three following circuit arrangements.

The easiest configuration to use would be the common collector (CC). The input resistance of the CC configuration is high because of the large negative voltage feedback in the base-emitter (BE) circuit. As the input voltage rises, the opposing voltage developed across the load resistance (fig. 4-12) substantially reduces the net voltage across the BE junction. By this action, the current drawn from the signal source remains low. From Ohm's law, you should know that a low current drawn by a relatively high voltage represents a

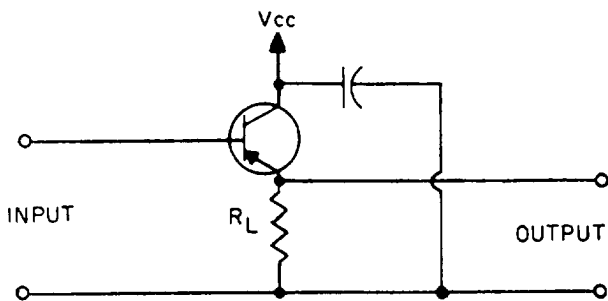


Figure 4-12.-Simplified schematic of a CC preamplifier.

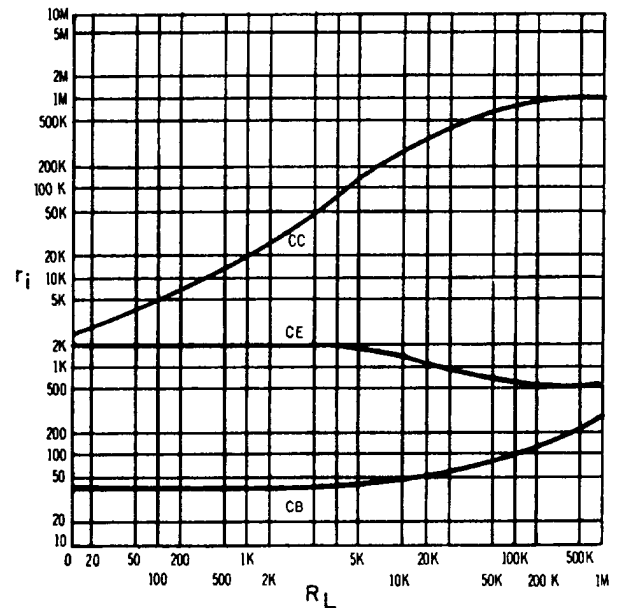


Figure 4-13.-Variations of r_i with R_L for each configuration.

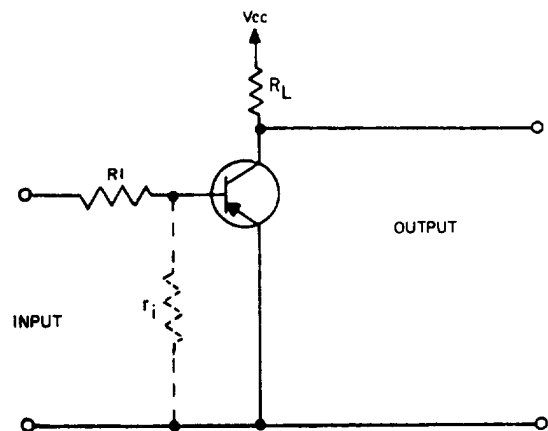


Figure 4-14.-Simplified schematic of a CE preamplifier with series resistor.

high impedance. If a load impedance of 500 ohms is used, the input resistance of a typical CC configuration will be over 30,000 ohms. The disadvantage of the CC configuration, however, is that small variations in the current drawn by the following stage cause large changes in the input impedance value.

The variation of input impedance, as a function of load impedance, for the CE, CB, and CC configurations is shown in figure 4-13.

The CE configuration maybe used to match a high source resistance by the addition of a series resistor in the base lead. The BE junction resistance (represented by r_i in fig. 4-14) for a typical CE configuration is approximate y 1,000 ohms if a load resistance of 30,000

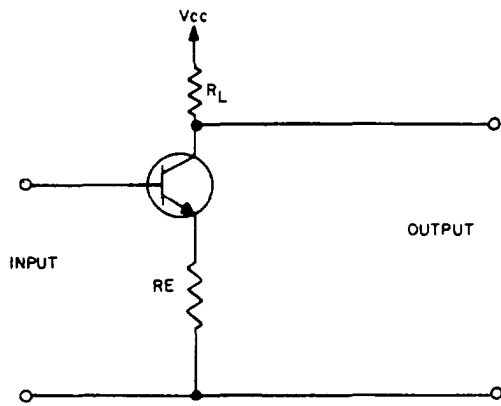


Figure 4-15.-Degenerated CE configuration.

ohms is used. The input resistance (r_i) may be increased by reducing the load resistance (R_L). For instance, decreasing the load resistance to approximately 10,000 ohms will increase r_i to approximately 1,500 ohms, as seen in the curve of figure 4-13.

Another method of increasing the input resistance (r_i) of a CE configuration is shown in figure 4-15. This type of circuit is the DEGENERATED CE configuration. If an unbypassed resistor (R_E) is inserted in the emitter lead, the signal voltage developed across this resistor opposes the input signal voltage.

As in the case of the CC configuration, this negative-feedback voltage or degenerative voltage causes an increase in the input resistance. With a bypassed resistor in the emitter lead, the input resistance of the CE configuration would be 2,000 ohms if a load resistor of 500 ohms were used (fig. 4-13). With an unbypassed resistor (R_E) of 500 ohms, the input resistance (r_i) will appear as approximately 20,000 ohms. The input resistance may be made to appear as any desired value (within practical limits) by the proper choice of R_L and R_E . Like the CE circuit with the series resistor, the total input resistance of the degenerated CE circuit will remain relatively constant with a varying load. However, the advantage of the degenerated CE configuration is that the unbypassed resistor (R_E) also acts as an emitter stabilizer and aids in stabilizing the transistor bias.

AUDIO OUTPUT STAGE

The voice coil of a dynamic speaker requires a low-impedance source, but the impedance of an output transistor is high. If the speaker is connected directly to the collector of the transistor, there is almost no audio because the transistor has no gain, due to the loss in

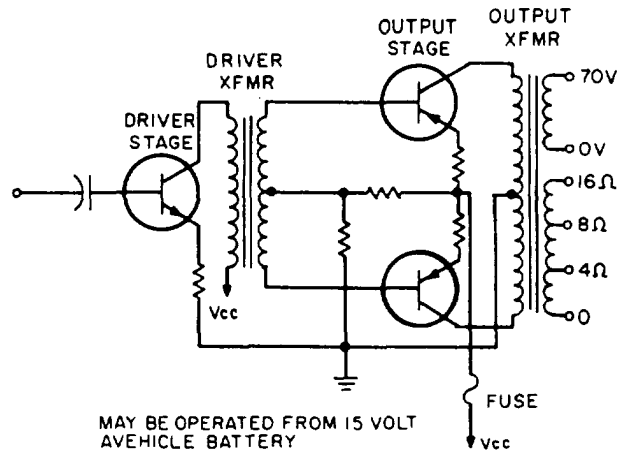


Figure 4-16.-Basic transistor output stages using two transformers.

mismatch of the transistor and the speaker. The output transformer in a basic audio output stage (fig. 4-16) matches the low impedance of the speaker coil to the high impedance of the output transistor. The primary of the transformer has more turns for high impedance; the secondary has fewer turns to provide the low impedance required by the speaker coil.

For a certain transistor, you can find the resistive value (impedance) that provides maximum gain with minimum distortion by consulting a transistor manual. Typical values range from approximately 2,000 to 5,000 ohms for one transistor, and they are doubled for push-pull outputs. Power to the secondary of a transformer is nearly equal to the power supplied by the primary due to the near unity coupling of the iron core in the transformer. The amount of power that an output transformer can handle is determined by the current and voltage ratings of its windings and by allowable losses.

IMPEDANCE RATIO

Recall that the output voltage of a transformer varies directly with the turns ratio and that the output current varies inversely with the turns ratio. The proportions in equation form are

$$\frac{E_p}{E_s} = \frac{N_p}{N_s} \text{ and } \frac{I_s}{I_p} = \frac{N_p}{N_s}$$

Multiply these proportions to get

$$\frac{E_p}{I_p} \times \frac{I_s}{E_s} = \frac{N_p^2}{N_s^2}$$

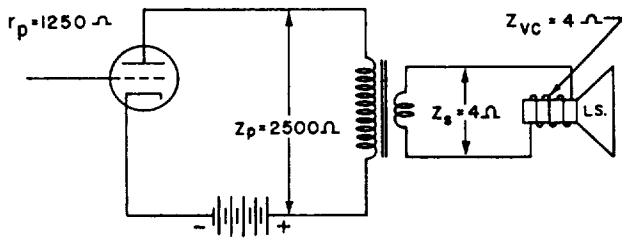


Figure 4-17.-Output transformer used as an Impedance matching device.

The primary impedance (Z) of a matching transformer is the ratio of rated primary voltage to rated primary current. Similarly, the secondary impedance (Z_s) is the ratio of rated secondary volts to rated secondary current. Substituting Z_p for

$$\frac{E_p}{I_p} \text{ and } \frac{1}{Z_s} \text{ for } \frac{I_s}{E_s},$$

you get the impedance ratio $\frac{Z_p}{Z_s} = \left(\frac{N_p}{N_s}\right)^2$

Thus, the ratio of the two impedances that a transformer can match is equal to the turns ratio squared. Also, the turns ratio is equal to the square root of the impedance ratio. Example: Find the turns ratio for the transformer shown in figure 4-17. The plate resistance is 1,250 ohms and the primary impedance is twice as much to permit maximum undistorted power output.

Solution:

$$\frac{N_p}{N_s} = \frac{\sqrt{Z_p}}{Z_s} = \frac{\sqrt{2,500}}{4} = \sqrt{625} = 25$$

MATCHING SPEAKER LOADS

Four equal impedances may be connected in a series-parallel arrangement to present the same impedance as one speaker to the amplifier (fig. 4-18, view A). In this case, the power delivered by the amplifier is divided equally among the four speakers. For better reliability, a series connection of two speakers in parallel is preferred. Should one speaker open up, the other three would continue to operate, but with a slight power change. However, in a parallel arrangement of two speakers in series (fig. 4-18, view A), if one speaker opens up, its other series member becomes inoperative and the system loses two speakers instead of one.

There may be times when speakers of unequal impedances are coordinated into an impedance-matched system because they may be the only kind available.

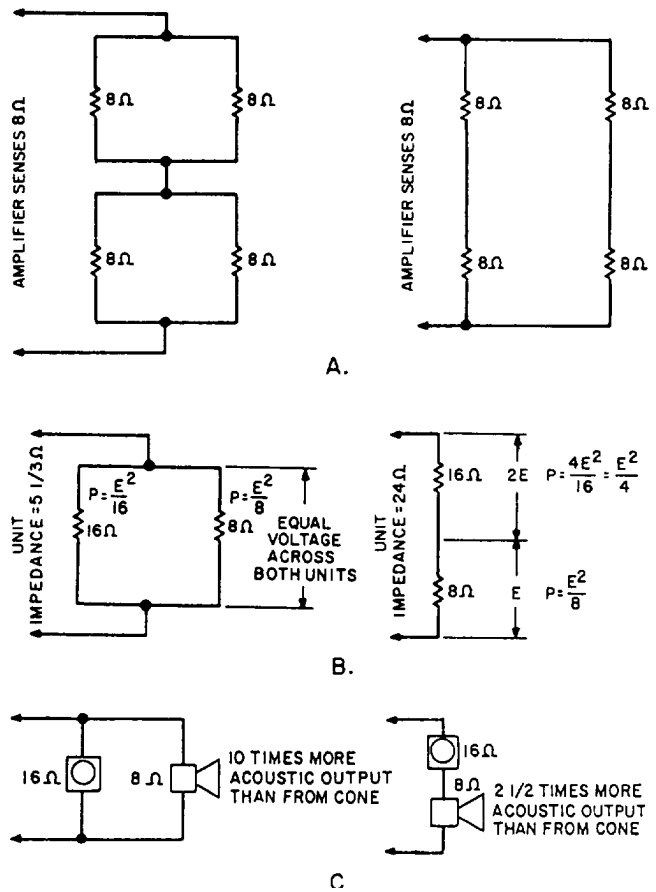


Figure 4-18.-Various speaker arrangements.

Such a combination might consist of an 8-ohm speaker and a 16-ohm speaker (fig. 4-18, view B). These two speakers in parallel result in an impedance of $5 \frac{1}{3}$ ohms. The voltage drop across the two speakers is the same for both and the power division would be 2:1 in favor of the 8-ohm speaker.

The alternate arrangement of series connection of the unequal-impedance speakers produces a branch impedance of 24 ohms with a power distribution that is 2:1 in favor of the 16-ohm speaker.

The ratio of power conversion efficiencies of the 8-ohm speaker to the 16-ohm speaker is at least 5:1. Combining this output efficiency ratio with the actual power taken by the two units gives

$$\frac{5}{1} \times \frac{2}{1} = 10$$

for the parallel connection (fig. 4-18, view C). This shows that the 8-ohm speaker, taking twice as much electrical power as the 16-ohm speaker, is putting out 10 times as much acoustic power.

The situation is not quite so upsetting in the series connection where the 8-ohm speaker accepts only one-half the power of the 16-ohm speaker. The power efficiency/power input ratio now becomes

$$\frac{5}{1} \times \frac{1}{2} = 2\frac{1}{2}$$

Taking only one-half the input power of the 16-ohm speaker, the 8-ohm speaker is producing 2 1/2 times as much acoustic power.

CONSTANT VOLTAGE SYSTEMS

With the constant-voltage distribution system, you can distribute audio power without having to match impedances or be too concerned about the effect of changes or additions on one part of the distribution system.

Assuming that the line voltage from the amplifier is constant, you can make easy, on-the-spot level adjustments of an individual speaker to suit the needs of the particular area served by that speaker on the line. In addition, you conserve audio power.

There are disadvantages to the system, too. Though wire runs are economical, each speaker or group of speakers requires its own line tie-in transformer and the main amplifier requires one master transformer.

In a matched-impedance system, the impedance must be calculated on each speaker group. Various speaker configurations will be necessary to get a usable impedance for any one branch. In a constant-voltage system, such as the 70.7-volt system (fig. 4-19), these values are precalculated by the manufacturer of the amplifiers and transformer. The line-matching transformer has taps on the primary, marked in units of power (watts), that will be delivered from the 70.7-volt line when the secondary is connected to a 4-, 8-, or 16-ohm speaker (fig. 4-19).

The precalculated values for the transformer will hold if the input voltage of the transformer is maintained at 70.7 volts. The amplifier gain control should be set at the point where the loaded amplifier delivers 70.7 volts RMS across the line at maximum load.

Though you need not do the calculating for impedance, it is easy to do. By formula, power P across an impedance equals the square of the voltage divided by the impedance; that is

$$\frac{E^2}{Z}$$

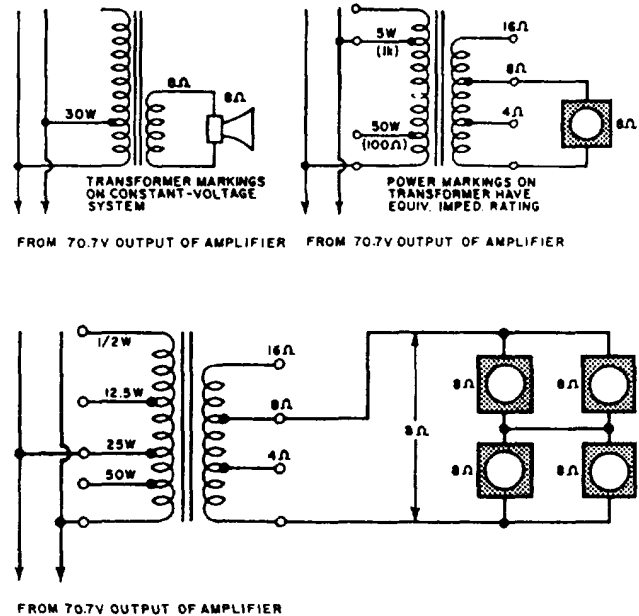


Figure 4-19.-Network mesh systems may be employed with the constant-voltage system where speaker group may be considered single load.

In a 70.7-volt system, power delivered is

$$\frac{(70.7)^2}{Z} \text{ or } \frac{5,000}{Z}$$

$$\text{impedance } Z \text{ equals } \frac{5,000}{P}$$

Problem: You have a transformer whose 8-ohm secondary is connected to an 8-ohm speaker. What should be the impedance of the primary to deliver 50 watts to the speaker from a 70.7-volt line?

Solution:

$$Z = \frac{5,000}{P} = \frac{5,000}{50} = 100 \text{ ohms}$$

If you wanted to draw 5 watts from the 70.7-volt line, the impedance of the transformer primary must be

$$\frac{5,000}{5} \text{ or } 1,000 \text{ ohms}$$

The individual constant-voltage transformer at each speaker makes it possible to quickly adjust the power into the speaker for a given sound coverage. Also, where there is a mix of cone speakers and horn speakers, you

can compensate quickly for the efficiency of the horn being greater than the cone's (fig. 4-18, view C). Suppose you want to get as much power out of a horn as the cone is delivering, and the cone is tied to the 5-watt tap of its transformer. Tying the horn to the 1-watt tap of its transformer would take into account the 5:1 efficiency ratio. Now you can make the horn twice as loud as the cone by stepping up its tapped position to the 2-watt level.

There is a limit to how many speakers you can tie across the line in this system, a limit that holds for the transformerless matched system as well. The total load on the system by all the speaker transformers and the speakers should not exceed the total power capacity of the amplifier. In the transformer system, you find the limit by adding the rating capacities of the transformers. In the matched-impedance system, you must measure the voltage across voltages to power values, then add them up.

On a constant-voltage line, what do you do with a transformer that is marked in impedance with no mention of power? Using the formula,

$$P = \frac{E^2}{Z}$$

convert the primary impedance of the transformer to power. As an example, suppose the transformer has a primary marked 167 ohms and a secondary marked 8 ohms. How much power does this transformer take from the 70.7-volt line for its 8-ohm speaker load?

Solution:

$$P = \frac{E^2}{Z} = \frac{5,000}{167} = 30 \text{ watts}$$

MODULAR UNITS

The demand for small, maintainable circuitry in military equipment has led to many different construction techniques. One of the most popular is modular construction. Since modular assemblies incorporate several subminiaturized features not found in conventional equipment, some specialized knowledge and tools are required for efficient repair and maintenance.

MAINTENANCE CONCEPT

A few definitions are helpful in understanding the terms involved. A module is, in the electronic sense, a

packaged functional assembly of wired electronic components for use with other such assemblies. A modular assembly is constructed with standardized units or modules. An equipment that consists of replaceable assemblies (any type) is said to be of unitized construction. Modular construction is a type of unitized construction that consists of modular assemblies.

For example, think of a carton of cigarettes. If each pack were a module, the carton would be an equipment of modular construction. Notice that the packs can be arranged differently without changing the outside dimensions of the carton. Although the cigarette packs are all the same size, the assemblies in many pieces of equipment are not.

By their original concept, many modular assemblies were not to be maintained in the field. The intention was to replace a faulty assembly and ship it to a repair facility. As assemblies became more complex, the point was reached where the supply system required for the replacement was too costly. Many of the original modules were potted to discourage maintenance personnel from tampering with the insides.

When the Navy reassessed this concept and called for shipboard maintenance of as much equipment as possible, most manufacturers began to make components accessible. However, it is difficult to dispel the conviction that modular assemblies are impossible to repair. This conviction may stem from a lack of experience in working with the printed circuits and the other components in modular assemblies. It is true that special tools and techniques are required. It is also true that satisfactory repairs can be made to any printed circuit by using a little care and common sense. With a little experience, repairs can be made as easily as in conventional assemblies, and often more easily because of improved accessibility.

REPAIR OF DEFECTIVE COMPONENTS

One of the time-consuming steps of troubleshooting is the identification of specific components. In conventionally wired equipment, components are not always easy to locate. The circuitry in the chassis can become confusing since related components are often positioned in different areas of the chassis.

In equipment that includes printed-circuit boards, identification of circuitry and components may be relatively simple. This type of circuit construction allows uniform placement of components. Just a quick, once-over glance of the circuitry is often all you need to

see to place the overall layout of the chassis in your mind and to quickly focus your attention on the area of concern.

Many commercial manufacturers have developed methods for quick identification. One of the most common is to impose a grid over a drawing of the board and a corresponding table that lists the part location. Another technique is to number points of interest on the schematic, then provide a guide to locate the points on the board.

Circuit tracing of the printed-circuit board maybe simpler than that of conventional wiring, due to increased uniformity. If the circuit board is translucent, a 60-watt light bulb placed under the side being traced will simplify circuit tracing. However, be careful not to overheat delicate circuit components. In this way, you can locate test points without viewing both sides of the board.

Resistance or continuity measurements can be made from the component side of the board. In some cases, a magnifying glass will help in locating very small breaks in the wiring. Voltage measurements can be made on either side of the board. However, a needlepoint probe is needed to penetrate the protective coating on the wiring. You also can locate hairline cracks by making continuity checks.

As a supervisor, you should make sure the people in your shop or maintenance crews observe the following precautions:

- Observe power supply polarities when measuring the resistance of the circuits containing transistors or other semiconductors. Such parts are polarity and voltage sensitive. Reversing the plate voltage polarity of a triode vacuum tube will keep the stage from operating, but generally will not injure the tube. Reversing the voltage applied to a transistor or other semiconductor will ruin it very quickly.

CAUTION: Ohmmeter voltage for checking transistors and their circuits should be 3 volts or less.

- Make certain power line leakage current is not excessive before applying ac power-operated test equipment or soldering irons. Use an isolation transformer with all test equipment and soldering irons operated on ac power, unless the equipment contains a transformer in its power supply or shows no leakage current. With all test equipment (whether transformer operated or not), connect a ground lead from the ground of the circuit to be tested to the test equipment ground.

- Apply a signal from test equipment by starting with a low output signal setting, then proceeding to the required signal level. Be sure the signal applied is below the rating given for the circuit under test.

- Make sure all parts in a circuit are secure before starting to test the circuit or turning on the equipment power. Do not cause an inductive kickback or transient current by moving loose connections, disconnecting parts, inserting or removing transistors or similar components, or changing modular units while the equipment power is on or under test.

- Remove all capacitance charges from parts and test equipment before attaching them to a modular assembly.

SUBSTITUTION OF PARTS

If a specified part cannot be obtained a suitable substitute part may be used temporarily, provided the substitute is replaced with the specified part as soon as it can be obtained. Make sure the failed part is the source of trouble and not the symptom of another failure.

RESISTORS AND CAPACITORS

The use of two or more resistors or capacitors in either series or parallel combinations to replace a burned-out component is a common practice.

When the proper size resistor or capacitor is not available, check your spare parts drawer to see if you can use what you have on hand in a series or parallel combination.

Tubes and Transistors

Substitution for defective tubes or transistors is usually an easy task. By consulting the proper substitution manual, and using the specifications for the tube or transistor you wish to replace, you can normally locate an acceptable substitute. Be certain to match the minimum specifications for the tube or transistor that you are trying to replace.

Relays and Switches

When replacing a relay, switch, or similar control device, be sure to consult the proper instruction book or blueprint to check the voltage and current ratings before you start looking for a substitute. When replacing a relay, also consider the resistance of the coil and the type and arrangement of the contacts. It may also be possible to make the replacement part yourself or do something

else that will reduce downtime. Remember, you are only looking for a temporary replacement.

SWITCHBOARD MAINTENANCE

Another duty of an IC Electrician is the maintenance of the power distribution systems assigned to your division. Normally, the required inspections and cleanings are outlined on maintenance requirement cards (MRCs). When the inspection and cleaning is due, you often think only of the main IC switchboard. The small local IC switchboards located in the engineering spaces and remote sections of the ship are forgotten. Auxiliary IC panels may have their own MRCs. You, as a supervisor, should make sure all power panels receive the attention needed.

INSPECTION AND CLEANING

At least once a year and during overhaul, each switchboard propulsion control cubicle, distribution panel, and motor controller should be de-energized and tagged out for a complete inspection and cleaning of all bus equipment. Inspection of the de-energized equipment should not be limited to visual examination but should include grasping and shaking electrical connections and mechanical parts to be certain that all connections are tight and that mechanical parts are free to function. Be certain no loose tools or articles are left in or around switchboards or distribution panels.

Check the supports of bus work to be certain the supports will prevent contact between bus bars of opposite polarity or contact between bus bars and grounded parts during periods of mechanical shock. Clean the bus work and the creepage surfaces of insulating material; be certain creepage distances (across which leakage currents can flow) are ample to prevent arcing. Bus bars and insulating materials can be cleaned with dry wiping clothes and a vacuum cleaner. Make sure the switchboard or distribution panel is completely de-energized and will remain so until the work is completed; avoid cleaning live parts because of the danger to personnel and equipment.

The insulated front panels of switchboards can be cleaned without de-energizing the switchboard. These panels can usually be cleaned by wiping with a dry cloth. However, a damp, soapy cloth can be used to remove grease and fingerprints. Then wipe the surface with a cloth dampened in clear water to remove all soap and dry with a clean, dry cloth. Cleaning cloths must be rung out thoroughly so no water runs down the panel. Clean a small section at a time and then wipe dry.

Rheostats and Resistors

Be certain the ventilation of rheostats and resistors is not obstructed. Replace broken or burned-out resistors. Temporary repairs of rheostats can be made by bridging burned-out sections when replacements are not available. Apply a light coat of petrolatum to the faceplate contacts of rheostats to reduce friction and wear. Be certain no petrolatum is left in the spaces between the contact buttons, as this may cause burning or arcing. Check all electrical connections for tightness and wiring for frayed or broken leads.

Instruments

The pointer of each switchboard instrument should read zero when the instrument is disconnected from the circuit. The pointer may be brought to zero by external screwdriver adjustment.

CAUTION: This should not be done unless proper authorization is given. Repairs to the switchboard instruments should be made only by the manufacturers, shore-repair activities, or tenders.

Fuses

Be certain fuses are the right size; clips make firm contact with the times; lock-in devices (if provided) are properly fitted; and all connections in the wiring to the fuses are tight.

Control Circuits

Control circuits should be checked to ensure circuit continuity and proper relay and contactor operation. Because of the numerous types of control circuits installed in naval ships, it is impractical to set up any definite operating test procedures in this training manual. In general, certain control circuits, such as those for starting motors or motor-generator sets, or voltmeter switching circuits are best tested by using the circuits as they are intended to operate under service conditions.

Protective circuits, such as overcurrent, reverse power, or reverse current circuits, usually cannot be tested by actual operation because of the danger involved to the equipment. These circuits should be visually checked and, when possible, relays should be operated manually to be certain the rest of the protective circuit performs its intended functions. Exercise extreme care not to disrupt vital power service or damage electrical equipment. Normally these checks and inspections are outlined on MRCs.

Bus Transfer Equipment

Bus transfer equipment should be tested weekly. For manual bus transfer equipment, manually transfer a load from one power source to another and check the mechanical operation and mechanical interlocks. For automatic bus transfer equipment, check the operation with the control switches. The test should include operation initiated by cutting off power (opening a normal feeder circuit breaker) to ascertain if an automatic transfer occurs. These tests and inspections are normally outlined on MRCs.

DIAGNOSTIC MAINTENANCE

When you must perform electrical repair on energized switchboards, first be sure to obtain the approval of the commanding officer. Personnel with telephone headsets should be stationed by circuit breakers to de-energize the switchboard immediately and call for help in case of emergency. The person doing the work should wear rubber gloves and should not wear loose clothing or metal articles.

Current Transformers

The secondary of a current transformer should never be open while the primary is carrying current. Failure to observe this precaution results in possible damage to the transformer and the generation of a secondary voltage that may be sufficient magnitude to injure personnel or damage insulation. A current transformer energized with an open-circuited secondary will overheat due to magnetic saturation of the core. Even though the overheating may have been insufficient to produce permanent damage, the transformer should be carefully demagnetized and recalibrated to ensure

accurate measurements. The secondary should always be short-circuited when it is not connected to a current coil.

Potential Transformers

The secondary of a potential transformer should never be short-circuited. The secondary circuit should be completed only through a high resistance, such as a voltmeter or a potential coil circuit, or should be open when the primary is energized. A short-circuited secondary allows excessive current to flow, which may damage the transformer.

IC GYRO WATCHSTANDING

As an IC1 or ICC, you will be required to set up and train an IC gyro room watch. This training should be tailored to the needs of your command with the commanding officer's authorization. This training should be documented and conducted according to the requirements of the *Standard Organization and Regulations of the U.S. Navy*, OPNAVINST 3120.32B.

ENGINEERING OFFICER OF THE WATCH

The engineering officer of the watch (EOOW) is a watch of great importance and responsibility. We will not cover it in great depth in this manual because it is covered by PQS. The EOOW requires qualification in other engineering watch areas before becoming qualified in that watch station. The important thing to remember is that the EOOW is responsible for the proper and safe operation and maintenance of all engineering equipment aboard ship.

APPENDIX I

GLOSSARY

ALIGNED SECTION– A section view in which some internal features are revolved into or out of the plane of the view.

APPLICATION BLOCK– A part of a drawing of a subassembly showing the reference number for the drawing of the assembly or adjacent subassembly.

ARCHITECT'S SCALE– Scale used when dimensions or measurements are to be expressed in feet and inches.

AUXILIARY VIEW– An additional plane of an object, drawn as if viewed from a different location. It is used to show features not visible in the normal projections.

AXONOMETRIC PROJECTION– A set of three or more views in which the object appears to be rotated at an angle, so that more than one side is seen.

BILL OF MATERIAL– A list of standard parts or raw materials needed to fabricate an item.

BLOCK DIAGRAM– A diagram in which the major components of a piece of equipment or a system are represented by squares, rectangles, or other geometric figures, and the normal order of progression of a signal or current flow is represented by lines.

BLUEPRINTS– Copies of mechanical or other types of technical drawings. Although blueprints used to be blue, modern reproduction techniques now permit printing of black on white as well as colors.

BODY PLAN– An end view of a ship's hull, composed of superimposed frame lines.

BREAK LINES– Lines to reduce graphic size of an object, generally to conserve paper space.

CASUALTY– An event or series of events in progress during which equipment damage and/or personnel injury has occurred. The nature and speed of these events are such that proper and correct procedural steps will only serve to limit equipment damage and/or personnel injury.

CENTER LINES– Lines that indicate the center of a circle, arc, or any symmetrical object; consist of alternate long and short dashes evenly spaced.

COMPUTER LOGIC– The electrical processes used by a computer to perform calculations and other functions.

DIGITAL– The processing of data by numerical or discrete units.

DRAWING NUMBER– An identifying number assigned to a drawing or a series of drawings.

DRAWING– The original graphic design from which a blueprint may be made; also called plans.

ELECTROMECHANICAL DRAWING– A special type of drawing combining electrical symbols and mechanical drawing to show the composition of equipment that combines electrical and mechanical features.

ELEMENTARY WIRING DIAGRAM– (1) A shipboard wiring diagram showing how each individual conductor is connected within the various connection boxes of an electrical circuit or system. (2) A schematic diagram; the term is sometimes used interchangeably with schematic diagram, especially a simplified schematic diagram.

EMERGENCY– Event or series of events in progress that will cause damage to equipment unless immediate, timely, and correct procedural steps are taken.

FAIL POSITION– Operating or physical position to which a device will go upon loss of its control signal.

FAIL– Loss of control signal or power to a component. Also breakage or breakdown of a component or component part.

FINISH MARKS– Marks used to indicate the degree of smoothness of the finish to be achieved on surfaces to be machined.

FORMAT– The general makeup or style of a drawing.

FUNCTION– To perform the normal or characteristic action of something, or a special duty or performance required of a person or thing in the course of work.

- INTERCONNECTION DIAGRAM**– Diagrams that show the cabling between electronic units, as well as how the terminals are connected.
- ISOMETRIC DRAWING**– A type of pictorial drawing. See isometric wiring diagram.
- ISOMETRIC WIRING DIAGRAM**– A diagram showing the outline of a ship, an aircraft, or other structure, and the location of equipment, such as panels and connection boxes and cable runs.
- LEADER LINES**– Thin, unbroken lines used to connect numbers, references, or notes to appropriate surfaces or lines.
- LEGEND**– A description of any special or unusual marks, symbols, or line connections used in the drawing.
- LOGIC DIAGRAM**– A type of schematic diagram using special symbols to show components that perform a logic or information processing function.
- MECHANICAL DRAWING**– See drawings. Applies to scale drawings or mechanical objects.
- MIL-STD**– Military standards. A formalized set of standards for supplies, equipment, and design work purchased by the United States Armed Forces.
- MODULE**– Subassemblies mounted in a section.
- MONITOR**– One of the principal operating modes of a data logger that provides a constant check of plant conditions.
- NORMAL MODE**– Operating condition at normal ahead speeds, differing from maneuvering, where certain functions, pumps, or valves are not required, while others are for proper operation of ship and machinery.
- NOTES**– Descriptive writing on a drawing to give verbal instructions or additional information.
- OBLIQUE DRAWING**– A type of pictorial drawing in which one view is an orthographic projection and the views of the sides have receding lines at an angle.
- ONE-LINE SKETCH**– Drawing using one line to outline the general relationship of various components to each other.
- ONE-LINE SCHEMATIC**– Drawing of a system using only one line to show the tie-in of various components; for example, the three conductors needed to transmit 3-phase power are represented by a single line.
- PERIPHERAL**– Existing on or near the boundary of a surface or area.
- PICTORIAL DRAWING**– A drawing that gives the real appearance of an object, showing the general location, function, and appearance of parts and assemblies.
- PLAN VIEW**– A view of an object or area as it would appear from directly above.
- REFERENCE NUMBERS**– Numbers used on one drawing to refer the reader to another drawing for more detail or other information.
- REVISION BLOCK**– Located in the upper right corner of a print. Provides a space to record any changes made to the original print.
- SCALE**– The ratio between the measurement used on a drawing and the measurement of the object it represents. A measuring device, such as a ruler, having special gradations.
- SCALING**– Applying a factor of proportionality to data or signal levels.
- SCHEMATIC DIAGRAM**– A diagram using graphic symbols to show how a circuit functions electrically.
- SHIP'S PLANS**– A set of drawings of all significant construction features and equipment of a ship, as needed to operate and maintain the ship. Also called onboard plans.
- SPAN**– Distance between two points.
- SPECIFICATION**– Detailed description or identification relating to quality, strength, or similar performance requirement.
- STATUS LOG**– Record of the instantaneous values of important conditions having analog values.
- SYMBOL**– Stylized graphical representation of commonly used component parts shown in a drawing.
- SYSTEM**– Major functioned section of an installation.
- SYSTEM INTERRELATION**– Specific individual operations in one system affecting the operation in another system.
- TITLE BLOCK**– A blocked area in the lower right corner of a print. Provides information to identify the drawing, its subject matter, origins, scale, and other data.
- VIEW**– A drawing of a side or plane of an object as seen from one point.

WATCH STATION- Duties, assignments, or responsibilities that an individual or group of individuals may be called upon to carry out; not necessarily a normally manned position with a watch bill assignment.

WIRING (CONNECTION) DIAGRAM- A diagram showing the individual connection within a unit and the physical arrangement of the components.

ZONE NUMBERS- Numbers and letters on the border of a drawing to provide reference points to aid in indicating or locating specific points on the drawing.

APPENDIX II

REFERENCES USED TO DEVELOP THIS NRTC

NOTE: Although the following references were current when this NRTC was published, their continued currency cannot be assured. When consulting these references, keep in mind that they may have been revised to reflect new technology or revised methods, practices, or procedures; therefore, you need to ensure that you are studying the latest references.

Chapter One

Electronics Technician 1 & C, NAVEDTRA 10192-F, Naval Education and Training Program Management Support Activity, Pensacola, Fla., 1987.

Engineering Administration, NAVEDTRA 10858-F1, Naval Education and Training Program Management Support Activity, Pensacola, Fla., 1988.

IC Electrician 2 & 1, NAVEDTRA 10561-1, Naval Education and Training Program Management Support Activity, Pensacola, Fla., 1988.

Molder 1 & C, NAVEDTRA 10585-C1, Naval Education and Training Program Management Support Activity, Pensacola, Fla., 1987.

Operational Reports, NWP 10-1-10, Chief of Naval Operations, Washington, D.C., November 1987.

Ships' Maintenance and Material Management (3-M) Manual, OPNAVINST 4790.4B, Chief of Naval Operations, Washington, D.C., August 1987.

Chapter Two

Opticalman 1 & C, NAVEDTRA 12217, Naval Education and Training Program Management Support Activity, Pensacola, Fla., 1991.

Quality Assurance Manual, COMNAVSURFLANTINST 9090.2, Commander Naval Surface Force United States Atlantic Fleet, Norfolk, Va., November 1985.

Chapter Three

Blueprint Reading and Sketching, NAVEDTRA 10077-F1, Naval Education and Training Program Management Support Activity, Pensacola, Fla., 1988.

Chapter Four

Blueprint Reading and Sketching, NAVEDTRA 10077-F1, Naval Education and Training program Management Support Activity, Pensacola, Fla., 1988.

IC Electrician 2 & 1, NAVEDTRA 10561-1, Naval Education and Training Program Management Support Activity, Pensacola, Fla., 1988.

INDEX

A

Amplifiers in announcing systems, 4-14 to 4-19
audio output stage, 4-16
constant voltage systems, 4-18 to 4-19
impedance matching in amplifiers, 4-15 to 4-16
impedance ratio, 4-16 to 4-17
matching speaker loads, 4-17

B

Blocked schematic, 4-2
Blocked text, 4-3
Blueprint parts, 3-2 to 3-8
application block, 3-6
bill of material, 3-4
drawing number, 3-2
finish marks, 3-6
legend or symbols, 3-7
meaning of lines, 3-8
notes and specifications, 3-6
reference numbers, 3-3
revision block, 3-2
scale, 3-4
title block, 3-2
zone numbers, 3-4
Blueprints, 3-1 to 3-17
handling of, 3-8
how prints are made, 3-1 to 3-2
parts of, 3-2 to 3-8
shipboard blueprints, 3-8

C

Cable marking, 3-13 to 3-14
Capacitors and resistors, 4-20
Casualty reports, 1-8 to 1-17
addressal procedures, 1-17
CANCEL CASREP, 1-16
casualty categories, 1-9
CORRECT CASREP, 1-16
INITIAL CASREP, 1-11 to 1-14
message format, 1-9 to 1-11
precedence, 1-17
reporting criteria, 1-11 to 1-17
rules and procedures, 1-9
timeliness, 1-17
UPDATE CASREP, 1-14 to 1-15
Chassis wiring, 4-10 to 4-11
repairing, 4-10
replacing, 4-10 to 4-11
testing, 4-10
Controlled material petty officers, 2-8
Controlled work package, 2-9 to 2-10
Corrective maintenance, 4-12 to 4-21
comparing waveforms, 4-14

evaluating performance, 4-12
maintenance concept, 4-19
measuring resistance, 4-13
measuring voltage, 4-13
modular units, 4-19
repair of defective components, 4-19 to 4-20
resistors and capacitors, 4-20
substitution of parts, 4-20
testing tubes, 4-13
troubleshooting, 4-12

D

Departure from specifications, 2-12 to 2-13
definition, 2-12
major departure, 2-12
minor departure, 2-13
reporting procedures, 2-12 to 2-13
Diagnostic maintenance, 4-22
current transformers, 4-22,
potential transformers, 4-22
Diagrams, 3-8 to 3-18
block, 3-15
electrical systems, 3-15
elementary wiring, 3-15
equipment wiring, 3-16
interconnection, 3-18
isometric wiring, 3-14
logic, 3-18
pictorial wiring, 3-8
schematic, 3-17
shipboard electrical prints, 3-10
single-line, 3-16
wiring deck plan, 3-15
Division officers, 2-7
Drawings and schematics, 4-1 to 4-3
drawings, 4-2
schematics, 4-1 to 4-3

E

Electrical prints, 3-8 to 3-17
block diagrams, 3-15
cable marking, 3-13 to 3-14
electrical systems diagrams, 3-15
elementary wiring diagram, 3-15
equipment wiring diagrams, 3-16
isometric wiring diagram, 3-14
numbering electrical units, 3-10
phase and polarity markings, 3-14
pictorial wiring diagram, 3-8
schematic diagrams, 3-17
shipboard electrical prints, 3-10
single-line diagrams, 3-16
wiring deck plan, 3-15
Electronic prints, 3-17 to 3-18
electromechanical drawings, 3-18

electronic prints, 3-18
logic diagrams, 3-18
Engineering officer of the watch, 4-22
Equipment inspections, 4-11

I

Inspection and cleaning, 4-21 to 4-22
bus transfer equipment, 4-22
control circuits, 4-21
fuses, 4-21
instruments, 4-21
rheostats and resistors, 4-21

L

Levels of essentiality, assurance, and control, 2-10 to 2-12
controlled material, 2-11
levels of assurance, 2-10
levels of control, 2-11
levels of essentiality, 2-10
SUBSAFE, 2-11 to 2-12

M

Maintenance, 4-1 to 4-22
amplifiers in announcing systems, 4-14 to 4-19
chassis wiring, 4-10 to 4-11
corrective maintenance, 4-12 to 4-21
drawings and schematics, 4-1 to 4-2
engineering officer of the watch, 4-22
preventive maintenance, 4-11 to 4-12
switchboard maintenance, 4-21 to 4-22
Symbolic Integrated Maintenance Manual (SIMM), 4-2 to 4-10
watch standing, 4-22
Maintenance dependency chart (MDC), 4-5 to 4-7
use of the MDC, 4-6 to 4-7
Message Format, 1-9 to 1-11
message errors, 1-10
message serialization, 1-10
message text structure, 1-11

P

Performance data records, 4-12
Planning, 1-2
PMS System, 1-2
Preventive maintenance, 4-11 to 4-12
equipment inspections, 4-11
performance data records, 4-12

Q

QA forms and records, 2-13 to 2-25
 QA Form 1, Material Receipt Control Record, 2-13
 QA Form 2, Material In-Process Control Tag, 2-13
 QA Form 3, Controlled Material Reject Tag, 2-13
 QA Form 4, Controlled Material Ship-to-Shop Tag, 2-13
 QA Form 4A, Ship-to-Shop Tag (General Use), 2-13
 QA Form 7, Controlled Material Inventory/Record, 2-16
 QA Form 8, Production Task Control Form, 2-16
 QA Form 8A, Material Requirements (Controlled Work Package Only), 2-16
 QA Form 9, Re-entry Control Form, 2-17
 QA Form 9A, Re-entry Control Supplement Sheet, 2-17
 QA Form 10, Re-entry Control Log, 2-17
 QA Form 12, Departure from Specification Report, 2-13
 QA Form 13, Quality Assurance Information Sheet, 2-17
 QA Form 15, Request for Release of Rejected Material or Workmanship, 2-17
 QA Form 16, Material Deficiency Report, 2-22
 QA Form 17, Test and Inspection Form-other than NDT, 2-22
Quality assurance, 2-1 to 2-25
 controlled work package, 2-9 to 2-10
 departure from specifications, 2-12 to 2-13
 levels of essentiality, assurance, and control, 2-10 to 2-12
 QA forms and records, 2-13 to 2-25
 quality assurance organization, 2-3 to 2-4
 quality assurance program, 2-1 to 2-3
 quality assurance requirements, training, and qualification, 2-6 to 2-8
 quality assurance terms and definitions, 2-8 to 2-9
 responsibilities for quality of maintenance, 2-5 to 2-6
Quality assurance officer, 2-4 to 2-7
Quality assurance organization, 2-3 to 2-4
Quality Assurance Program, 2-1 to 2-3
 concept of quality assurance, 2-2
 goals, 2-3
 operation of, 2-8
 program components, 2-2
 quality assurance link to maintenance, 2-3

Quality assurance requirements, training, and qualification, 2-6 to 2-8
Quality assurance supervisors, 2-7
Quarterly reports, 1-8

R

Repair officer, 2-7
Reports, 1-8 to 1-19
 casualty reports, 1-8 to 1-17
 quarterly reports, 1-8
 situation reports, 1-18 to 1-19
Resistors and capacitors, 4-20

S

Scales, 3-4
 architects', 3-4
 engineers', 3-4
 graphic, 3-4
 metric, 3-4
Scheduling of work, 1-3 to 1-6
Schematics, 4-1 to 4-3
 blocked schematic, 4-2 to 4-3
Ship quality control inspectors, 2-4 to 2-6
Ships' drawings and diagrams, 3-1 to 3-18
 blueprints, 3-1 to 3-8
 electrical prints, 3-8 to 3-17
 electronic prints, 3-17 to 3-18
Shop supervision, 1-1 to 1-8
 estimating work 1-6 to 1-7
 information on incoming work 1-3
 maintenance and repair, 1-1
 materials and repair parts, 1-7 to 1-8
 planning, 1-2
 priority of jobs, 1-3
 scheduling of work, 1-3 to 1-6
Situation reports, 1-18 to 1-19
Submarine Safety Program (SUBSAFE), 2-11 to 2-12
Switchboard maintenance, 4-21 to 4-22
 diagnostic maintenance, 4-22
 inspection and cleaning, 4-21
Symbolic Integrated Maintenance Manual (SIMM), 4-2 to 4-10
 alignment procedures, 4-7
 blocked schematic, 4-2 to 4-3
 blocked text, 4-3 to 4-4
 improvements, 4-9 to 4-10
 indexing of related information, 4-7
 maintenance dependency chart, 4-5 to 4-7
 operating procedures, 4-5
 parts location and identification, 4-9
 precise-access blocked diagram, 4-4 to 4-5
 repair of mechanical assembly, 4-9

T

Technical administration, 1-1 to 1-19
 preparation of reports, 1-8 to 1-19

shop supervision, 1-1
Troubleshooting, 4-12

W

Watch standing, 4-22
Wiring chassis, 4-10 to 4-11

ASSIGNMENT 1

Textbook Assignment: "Technical Administration," and "Quality Assurance," chapters 1 and 2, pages 1-1 through 2-5.

- 1-1. The shop supervisor is responsible for checking and inspecting completed repairs.
1. True
 2. False
- 1-2. You can ensure proper personnel employment by the use of which of the following documents?
1. Quarterly schedule
 2. Cycle schedule
 3. Weekly work schedule
 4. MRC (job card)
- 1-3. Which of the following statements is true concerning an MRC (job card)?
1. Cards are made out for a standard system and cannot be modified
 2. Card job procedures are not in any sequential order
 3. Cards can only be used on certain ships
 4. Cards should be tailored for use on your ship through the use of the PMS feedback report
- 1-4. What person must give permission for emergency repairs?
1. The executive officer
 2. The officer of the deck
 3. The division officer
 4. The chief engineer
- 1-5. When a job is received by a repair facility, when should the planning commence?
1. As soon as possible
 2. When the job is started
 3. One week after receipt of the job
 4. The same day the job is received
- 1-6. Except when dealing with a sincere personal problem, what is the correct procedure to use when you must talk with one of a subgroup supervisor's subordinates?
1. Talk to the person alone
 2. Talk to the subgroup supervisor; then talk to the person
 3. Have the subgroup supervisor accompany the person
 4. Talk to the person alone; then talk to the subgroup supervisor
- 1-7. Which of the following is the correct priority for planning and scheduling work?
1. Routine, deferred, urgent
 2. Urgent, routine, deferred
 3. Urgent, deferred, routine
 4. Routine, urgent, deferred
- 1-8. Which of the following information should be considered in determining the priority of a task (job)?
1. The ship's schedule and the effect the equipment will have on the ability of the ship to perform its mission
 2. Whether the work requires someone with special skills
 3. Whether or not all the required parts and materials are available
 4. All of the above
- 1-9. What OPNAV form is used to defer a maintenance action?
1. 4790/2K
 2. 4790/2R
 3. 4790/P1
 4. 4790/2L

- 1-10. What is the advantage of assigning a difficult or complex job to a less experienced person working under close supervision instead of to a more experienced person?
1. You can assign a low priority to the job
 2. You will give the less experienced person a chance to gain experience in such tasks
 3. You will not have to furnish a drawing or general statement about the job
 4. You will not have to inspect the job after it is completed
- 1-11. Which of the following factors should you consider when planning a shipboard maintenance action or repair work?
1. Size of the job
 2. Material needed and what material is available
 3. Priority of the job
 4. Each of the above
- 1-12. The work center supervisor should review the week's work with which of the following personnel to determine which jobs need to be done right away?
1. The division officer
 2. The chief engineer
 3. The executive officer
 4. The commanding officer
- 1-13. Which of the following is one of the main purposes for inspecting a job after it is finished?
1. To sign off the job order
 2. To evaluate the worker's skills and knowledge
 3. To evaluate the priority assigned to the job
 4. To estimate the man-hours for the job
- 1-14. In estimating time to complete a task, which of the following factors is NOT your responsibility?
1. Time for another shop to do its job
 2. Time to be spent in other activities, such as drills
 3. Rate at which personnel can do the work
 4. Priority of the various jobs assigned to your shop
- 1-15. The number of individuals who can work effectively on a job at the same time is an important factor when making which of the following estimates?
1. The amount of material that will be wasted on the job
 2. The kind of materials the job requires
 3. The time it takes to complete a job
 4. The time that will be lost to drills, inspections, and work parties
- 1-16. When work is sent to an outside activity, what OPNAV form should you use?
1. 4790/2Q
 2. 4790/2K
 3. 4790/2R
 4. 4790/2L
- 1-17. Estimating the materials required for a certain repair job is often more difficult than estimating the time and labor required for the job.
1. True
 2. False

- 1-18. Which of the following is a good way to get a handle on what is happening during each step of a job?
1. Ask the commanding officer
 2. Question the chief engineer
 3. Talk to the command master chief
 4. Consult the ship's master training schedule and monthly training plan
- 1-19. Which of the following documents are NOT useful in planning a job?
1. Rate training manuals
 2. Ship's drawings
 3. Blueprints
 4. Manufacturers' technical manuals
- 1-20. Which of the following is NOT a duty of supply officers?
1. Buy material
 2. Stow material
 3. Make out the abandon ship bill
 4. Account for most types of stores
- 1-21. Which of the following information will you NOT likely find on the nameplate of a piece of equipment?
1. Serial number, stock number, and model number
 2. Operating values, such as volts, current, and speed
 3. Manufacturer's name
 4. Materials required for repairs
- 1-22. To locate repair materials not specified in the instructions accompanying a job, which of the following is/are excellent sources to use?
1. Ships' plans, blueprints, and drawings
 2. Engineering log book
 3. Engineer's bell book
 4. Gyro maintenance log
- 1-23. All materials in the supply system are assigned which of the following numbers?
1. Part number
 2. Job sequence number
 3. Stock number
 4. Social security number
- 1-24. The administration and supervision of maintenance and repair of the gyrocompass is the responsibility of which of the following personnel?
1. Gyro technician
 2. Gyro shop personnel
 3. Commanding officer
 4. Gyro officer
- 1-25. After a casualty occurs, a CASREP should be submitted within what maximum period of time?
1. 12 hr
 2. 18 hr
 3. 24 hr
 4. 48 hr
- 1-26. Once a casualty is reported, what person/office should receive hard copies of CASREP messages?
1. CNO, fleet commanders, and ship's parts control center
 2. CNO, squadron commanders, and commanding officer
 3. CNO, fleet commanders, and commanding officer
 4. Commanding officer, squadron commanders, and ship's parts control center
- 1-27. What is the maximum number of casualty categories used by all commands except for NAVEDTRACOMs?
1. Five
 2. Two
 3. Three
 4. Four

- 1-28. An UPDATE CASREP contains information similar to that submitted in which of the following documents?
1. CASCOR
 2. CASCAAN
 3. SITREP
 4. INITIAL CASREP
- 1-29. What type of CASREP identifies the status of the casualty and parts and/or assistance requirements?
1. UPDATE
 2. INITIAL
 3. CANCEL
 4. CORRECT
- 1-30. A CORRECT CASREP should be submitted in which of the following situations?
1. When the casualty has been corrected
 2. Within 24 hours of discovery of a casualty
 3. When a casualty is over 48 hours old
 4. When there is more information to report than originally known
- 1-31. What total number of casualty categories do NAVEDTRACOM activities use?
1. Six
 2. Five
 3. Three
 4. Four
- 1-32. For additional information on the Status of Resources and Training System (SORTS), you should refer to what chapters of NWP 10-1-10?
1. 3 and 4
 2. 1 and 4
 3. 1 and 5
 4. 5 and 6
- 1-33. The casualty category is NOT required in the casualty set in all CASREPs.
1. True
 2. False
- 1-34. The decision logic tree is used for which of the following purposes?
1. To determine the unit's overall status category
 2. To determine the M-rating
 3. To determine the casualty category and whether or not a casualty is required
 4. Each of the above
- 1-35. The serialization for a CASREP will appear in which, if any, of the following places?
1. After the message classification line
 2. Before the message classification line
 3. In the message classification line
 4. None of the above
- 1-36. Which of the following statements is true concerning the serial numbers for CASREPs?
1. They are in nonsequential order
 2. They are sequential from 1 through 99
 3. New sequence numbers start after submission of number 99
 4. They are sequential from 1 through 999
- 1-37. CASREP messages transmitted with errors can only be corrected with what document?
1. CORRECT CASREP
 2. CANCEL CASREP
 3. UPDATE CASREP
 4. Routine message
- 1-38. How many different types of data sets are used in CASREP messages?
1. One
 2. Two
 3. Three
 4. Four

- 1-39. What casualty set is used to report whether or not a unit requires outside assistance to repair an equipment casualty?
1. 1PARTS
 2. 1STRIP
 3. ASSIST
 4. AMPN
- 1-40. When a unit requires assistance and/or parts to repair a casualty, schedule information must be reported in the RMKS set for what specific period of time?
1. 7 days
 2. 14 days
 3. 20 days
 4. 30 days
- 1-41. What total number of casualties can be updated per UPDATE CASREP message?
1. One
 2. Two
 3. Three
 4. Four
- 1-42. When must a unit submit a CANCEL CASREP?
1. When additional malfunctions are discovered
 2. When equipment that has been the subject of a CASREP is scheduled to be repaired during an overhaul period
 3. When parts are received
 4. When there is a need to complete information reporting requirements
- 1-43. CASREP messages must be assigned the highest precedence consistent with the importance of the types of report, the location, and the tactical situation.
1. True
 2. False
- 1-44. What are situation reports (SITREPs)?
1. Reports required to report outstanding casualties
 2. Reports required when there is a need to revise previously submitted information
 3. One-time reports required when certain situations arise
 4. Reports that allow operational and staff authorities to request necessary resources
- 1-45. Which of the following programs provides maintenance personnel with information and guidance necessary to administer a uniform policy of maintenance and repair?
1. 3-M
 2. QA
 3. IEM
 4. COSAL
- 1-46. The achievement of an effective QA program depends on which of the following factors?
1. Speed of repair, special skills, and knowledge
 2. Speed of repair, special skills, and prevention of maintenance problems
 3. Knowledge, prevention of maintenance problems, and speed of repairs
 4. Knowledge, prevention of maintenance problems, and special skills
- 1-47. What number is assigned to the SQCI by the QAO for use on all forms and tags that require initials as proof that certified tests and inspections were completed?
1. Social security number
 2. Stock number
 3. Personal serial number
 4. Personal pin number

- 1-48. The QA manual for each TYCOM sets forth which of the following requirements?
1. Maximum QA requirements
 2. Minimum QA requirements
 3. Specific QA requirements for ships
 4. Specific QA requirements for shore
- 1-49. The instructions contained in the QA manual apply to what organizations?
1. Shore activities only
 2. Combat ships only
 3. Repair ships only
 4. Every ship and activity of the force
- 1-50. If conflicts exist between the QA manual and previously issued letters and transmittals by appropriate force commanders, the letters and transmittals take precedence.
1. True
 2. False
- 1-51. Which of the following is considered part of job execution?
1. Completing QA forms
 2. Meeting controlled material requirements
 3. Training personnel
 4. Auditing programs
- 1-52. The administrative part of the QA program consists of which of the following parts?
1. Preparing work procedures
 2. Requisitioning material
 3. Monitoring programs
 4. Testing and recertifying
- 1-53. Technical specifications can be ruled out in the interest of completing the job quickly.
1. True
 2. False
- 1-54. Which of the following factors spawned the need for the development of the QA program?
1. The ever-increasing technical complexity of present-day surface ships and submarines
 2. The ever-increasing workload of the work centers aboard ship
 3. The ever-increasing lack of formal training for technicians aboard ship
 4. Each of the above
- 1-55. A certain level of confidence required in the reliability of repairs made is known as what type of level?
1. Level of assurance
 2. Level of control
 3. Level of essentiality
 4. Level of reliability
- 1-56. Which of the following is one of the main goals of the QA program?
1. To ensure every repair of any failed equipment is documented
 2. To decrease the time between equipment failure
 3. To ensure the safety of personnel while working on SUBSAFE items
 4. To protect personnel from hazardous conditions
- 1-57. What is the most difficult part of planning a job?
1. Determining which technical specification sources are applicable to a particular job
 2. Determining the number of personnel required to accomplish a specific job
 3. Determining what material is needed
 4. Determining how much time is required to accomplish the job

- 1-58. What person is responsible for maintaining the ship's QA records and test and inspection reports?
1. The type commander
 2. The commanding officer
 3. The repair officer
 4. The quality assurance officer
- 1-59. The QA program (Navy) begins with which of the following personnel?
1. The commanding officer of the ship
 2. The type commander
 3. The quality assurance officer
 4. The commanders in chief of the fleet
- 1-60. What person is responsible to the force commander for QA in the maintenance and repair of the ship?
1. The type commander
 2. The commanding officer
 3. The quality assurance officer
 4. The ship quality control inspector
- 1-61. What person(s) provide(s) instruction, policy, and overall direction for implementation and operation of the force QA program?
1. The commanders in chief of the fleet
 2. The type commanders
 3. The commanding officer
 4. The quality assurance officer
- 1-62. Which of the following personnel is responsible for initiating a departure from specification report?
1. The work center supervisor
 2. The quality control inspector
 3. The person finding or causing the departure
 4. The quality assurance officer
- 1-63. The quality assurance officer is responsible to the commanding officer for which of the following tasks?
1. Coordinating the ship's 3-M training
 2. Conducting the ship's QA training
 3. Reviewing procedures and work packages prepared by the ship before submission to the engineer
 4. Reviewing personnel records to ensure that everyone is qualified as quality assurance inspectors
- 1-64. The SQCI is responsible for which of the following actions?
1. Planning work for the work center
 2. Scheduling preventive maintenance
 3. Assigning work to maintenance personnel
 4. Inspecting all work for conformance to specifications
- 1-65. Which of the following personnel must know the specifications limits of a job and the purpose of these limits?
1. Executive officer only
 2. Leading petty officer only
 3. Chief petty officer only
 4. Each person involved in the job
- 1-66. Any technical or administrative directive that defines repair criteria is known as a/an
1. calibration
 2. acceptance
 3. specification
 4. inspection record
- 1-67. What term is defined as a written instruction designed to produce acceptable and reliable products, whether produced or repaired?
1. Inspection
 2. Procedure
 3. Process
 4. SUBSAFE

- 1-68. The effective operation of a successful QA program requires the effort of which of the following personnel?
1. Commanding officer only
 2. Quality assurance officer only
 3. Engineering officer only
 4. All hands
- 1-69. The person with the most direct concern for quality workmanship within a work center is which of the following personnel?
1. The production supervisor
 2. The shop craftsmen
 3. The division officer
 4. The department head
- 1-70. Which of the following is an example of a QA action performed following the completion of a series of tasks?
1. Final inspection
 2. In-process inspection
 3. Receiving inspection
 4. Screening inspection
- 1-71. What type of inspection determines the condition of material, maintenance requirements, and disposition and correctness of accompanying records and documents?
1. Final inspection
 2. Midterm inspection
 3. In-process inspection
 4. Receiving or screening inspection
- 1-72. Which of the following actions is NOT considered to be part of the in-process inspection?
1. A periodic or special evaluation of details, plans, policies, procedures, product directives, and records
 2. The witnessing of task performance
 3. The application of torque and functional testing
 4. Adjusting, assembling, servicing, and installation
- 1-73. What person is responsible for coordinating and administering the QA program within a work center?
1. SQCI
 2. QAO
 3. Work center supervisor
 4. Division officer

ASSIGNMENT 2

Textbook Assignment: "Quality Assurance (continued)," and "Ship's Drawings and Diagrams," chapters 2 and 3, pages 2-6 through 3-18.

- 2-1. Which of the following is NOT a responsibility of the SQCI?
1. Developing a thorough understanding of the QA program
 2. Assigning jobs that require a work package
 3. Maintaining records and files to support the QA program
 4. Ensuring that all work center personnel are familiar with applicable QA manuals by conducting training
- 2-2. What term describes a management function that attempts to eliminate defective products?
1. Quality assurance
 2. Quality control
 3. Audit
 4. Controlled material
- 2-3. Which of the following personnel is/are responsible for conducting internal audits as required and taking corrective action on noted discrepancies?
1. Division officer
 2. Quality assurance officer
 3. SQCI
 4. All of the above
- 2-4. Which of the following personnel is responsible for inspecting, segregating, stowing, and issuing controlled material?
1. CMPO
 2. SQCI
 3. Division officer
 4. Work center supervisor
- 2-5. What QA function is performed to identify production standards or material characteristics during manufacture or a repair cycle that may not be detectable during final inspection?
1. Quality assurance
 2. Quality control
 3. In-process inspection
 4. Technical repair standardization
- 2-6. Alternate SQCIs (backup personnel) do not need to have the same degree of qualifications and will not be given the same responsibilities as normally assigned SQCIs.
1. True
 2. False
- 2-7. CMPOs are trained and qualified by the QA supervisor and are normally of what paygrade(s)?
1. E3 and E4
 2. E4 only
 3. E5 only
 4. E4 and E5
- 2-8. The commanding officer assigns the primary duty of which of the following personnel in writing according to the QA manual?
1. SQCI
 2. QAO
 3. CMPO
 4. PAO
- 2-9. What person is responsible for training and qualifying the work center SQCI?
1. Quality assurance officer
 2. Division officer
 3. Ship quality control inspector
 4. Quality assurance supervisor

- 2-10. Which of the following personnel is/are given a written examination as well as an interview before becoming qualified to do the assigned job?
1. QAO
 2. CMPO only
 3. SQCI only
 4. CMPO and SQCI
- 2-11. In addition to a good personnel orientation program, which of the following elements are required for an effective QA program?
1. A comprehensive training program, use of proper repair procedures, and a uniform liberty policy
 2. A comprehensive training program, use of proper repair procedures, and uniform inspection procedures
 3. Use of proper repair procedures, use of new tools and equipment, and uniform inspection procedures
 4. Use of new tools and equipment, proper working environment, and uniform liberty policy
- 2-12. What number provides traceability from the work package to other certification documentation?
1. Job control number
 2. Identification number
 3. Serial number
 4. Stock number
- 2-13. What term best describes when an authorized representative approves specific services rendered?
1. Quality control
 2. Inspection
 3. Acceptance
 4. Inspection record
- 2-14. The examination and listing of components and services to determine whether they conform to specified requirements is defined by what term?
1. Acceptance
 2. Inspection
 3. In-process inspection
 4. Calibration
- 2-15. If, during the repair process, you must change the original scope of the work to be performed, what procedure must you initiate?
1. Revision
 2. Addendum
 3. Automated work request
 4. Controlled work package
- 2-16. Which of the following information is NOT provided to a supervisor in a CWP?
1. QA form instructions
 2. QC procedures
 3. QC techniques
 4. Stowage location of SUBSAFE material
- 2-17. What procedure should you follow if, during a repair process involving simultaneous performance of procedure steps, the steps are in different locations?
1. Reject the job and send the CWP back to planning
 2. Make a copy of the CWP with its documentation for each job site
 3. Use locally developed practices
 4. Have the CWP at one job site only
- 2-18. What term describes the documentation contained inside a CWP?
1. Revision
 2. Enclosures
 3. Addendum
 4. Specifications

- 2-19. What term indicates the impact that catastrophic failure of the associated part or equipment would have on the ship's mission capability and personnel safety?
1. Levels of assurance
 2. Levels of essentiality
 3. Levels of necessity
 4. Levels of controls
- 2-20. Which, if any, of the following levels of assurance normally requires both quality control and tests and/or inspection methods?
1. A
 2. B
 3. C
 4. None of the above
- 2-21. What level of assurance provides for "as necessary" verification techniques?
1. A
 2. B
 3. C
 4. I
- 2-22. Which of the following is NOT a description of controlled material?
1. It has special markings
 2. It has accountability throughout the repair or manufacturing process
 3. It is stowed separately
 4. It must be open purchased
- 2-23. What term is defined as the degrees of control measures required to assure reliability of repairs made to a system, subsystem, or component?
1. In-process inspection
 2. Levels of assurance
 3. Levels of control
 4. Levels of essentiality
- 2-24. What person must inspect controlled material for required attributes before it can be used in a system or component?
1. QAO
 2. SQCI
 3. CMPO
 4. DCPO
- 2-25. SUBSAFE requirements are split into what total number of categories?
1. Five
 2. Two
 3. Three
 4. Four
- 2-26. What term is defined as any submarine system determined by NAVSEA to require the special material or operability requirements of the SUBSAFE program?
1. SUBSAFE boundary
 2. SUBSAFE barrier
 3. SUBSAFE material
 4. SUBSAFE system
- 2-27. What term is defined as the record of objective evidence establishing the requisite quality of the material, component, or work done?
1. Procedure
 2. Documentation
 3. Controlled work package
 4. Departure from specification
- 2-28. Which of the following problems may cause a worker to fail to report a departure from specification?
1. Lack of training
 2. Lack of time for adequate planning
 3. Lack of adequate inspection
 4. Each of the above

- 2-29. When there is a lack of compliance with cognizant technical documents, drawings, or work procedures during a maintenance action that will not be corrected before the ship gets underway, what document is required?
1. OPNAV Form 4790/2
 2. OPNAV Form 4790/21
 3. ACN
 4. Departure from specification
- 2-30. What type of departure from specification must be approved by the appropriate authority?
1. Major only
 2. Minor only
 3. Semiminor only
 4. Any departure from specification
- 2-31. What are the two types of departure from specifications?
1. Major and minor
 2. Major and semiminor
 3. Minor and semiminor
 4. Semiminor and minimal
- 2-32. What person is responsible for reporting a departure from specification?
1. SQCI
 2. CMPO
 3. QAO
 4. The person who discovered or caused the departure
- 2-33. Which of the following terms is defined as a set of actions written in a special sequential order by which maintenance action, a test, or an inspection is done using specific guidelines, tools, and equipment?
1. Process
 2. Procedure
 3. Documentation
 4. Audit
- 2-34. What QA form lists all tests and inspections that must be at each step?
1. 12
 2. 13
 3. 16
 4. 17
- 2-35. What QA form is attached by supply QA, or shop personnel to provide traceability of accepted controlled material from receipt inspection through final inspection?
1. 7
 2. 2
 3. 3
 4. 4A
- 2-36. What QA form is used by the CMPO to provide a standard inventory record of controlled material received and issued?
1. 7
 2. 8
 3. 8A
 4. 9
- 2-37. What QA form is used to identify and control material and equipment in a positive manner from ship to repair shop?
1. 9
 2. 9A
 3. 4A
 4. 4
- 2-38. Which of the following are reproduced copies of mechanical or other types of technical drawings?
1. Electrical prints
 2. Electronic prints
 3. Blueprints
 4. Electromechanical drawings

- 2-39. What is the meaning of the term "blueprint reading"?
1. Reading aloud the printed matter in the legends
 2. Giving oral directions to the operator of the machine reproducing the blueprint
 3. Interpreting the ideas expressed on drawings
 4. Reading related matter to help you understand the blueprint symbols
- 2-40. Which of the following printing processes produces prints with black, blue, or maroon lines on a white background?
1. VanDyke printing
 2. Ozalid printing
 3. Black-and-white printing
 4. Mimeograph printing
- 2-41. Which of the following processes may be used for reproducing small drawings or sketches?
1. Mimeographing
 2. Dittoing
 3. Photostating
 4. Each of the above
- 2-42. Blueprints are printed directly on sensitized paper from which of the following sources?
1. A drawing or tracing on translucent paper or cloth
 2. An original drawing on a steel plate
 3. A photographic negative of a drawing
 4. A drawing copied onto a clear glass sheet
- 2-43. Which of the following references gives the list of graphic symbols for electrical and electronic diagrams?
1. MIL-STD-100E
 2. MIL-STD-15 (Part No. 2)
 3. ANSI Y32.2
 4. ANSI Y39.2
- 2-44. In which corner of a blueprint is the title block located?
1. Upper right
 2. Lower left
 3. Upper left
 4. Lower right
- 2-45. In which corner of a blueprint is the revision block usually found?
1. Lower right
 2. Lower left
 3. Upper right
 4. Upper left
- 2-46. If a blueprint bearing the drawing number 5123476-C is revised, what will be the revised drawing number of the revised print?
1. 5123476-C1
 2. 5123476-D
 3. 5123476-1C
 4. 1-5123476
- 2-47. If the actual length of an object is 5 inches, what is the length of its drawing on a blueprint with a scale of 2" = 1"?
1. 1/2 in.
 2. 2 1/2 in.
 3. 5 in.
 4. 10 in.
- 2-48. What number on a blueprint serves the same purpose as numbers and letters printed on the borders of maps?
1. Zone
 2. Reference
 3. Scale
 4. Drawing

- 2-49. Although the scale of a blueprint indicates the dimensions of the drawing relative to the actual size of the object, you should not measure the drawing to determine the actual size of the object because of which of the following reasons?
1. You must verify the accuracy of the scale
 2. You must verify the accuracy of the blueprint
 3. You must avoid errors made because of incorrect interpretation of the scale
 4. You must avoid any errors made in the original drawing
- 2-50. Which scale is divided into decimal graduations?
1. Graphic
 2. Engineers'
 3. Metric
 4. Architects'
- 2-51. Which scale indicates the number of feet or miles represented by an inch?
1. Architects'
 2. Engineers'
 3. Graphic
 4. Metric
- 2-52. Which block of a blueprint lists the parts and materials used on or required by the print concerned?
1. Application
 2. Title
 3. Notes and Specifications
 4. Bill of material
- 2-53. What information appears in the Used On column of a blueprint's application block?
1. Model number or equivalent designation of the assembled unit of which the part is a component
 2. Drawing or model number of the next larger assembly to which the drawing applies
 3. Authentication for the blueprint
 4. Second part of a two-detail blueprint
- 2-54. In which corner of a blueprint is the legend of symbols located?
1. Upper right
 2. Lower right
 3. Upper left
 4. Lower left
- 2-55. A finish mark on a blueprint indicates that the surface of the part must be
1. tempered
 2. painted or plated
 3. machined
 4. polished and painted
- 2-56. What type of plan is submitted with bids, or other plans, before award of a contract?
1. Standard plans
 2. Preliminary plans
 3. Working plans
 4. Contract plans
- 2-57. What type of plans are a designated group of plans illustrating features considered necessary for shipboard reference?
1. Standard plans
 2. Corrected plans
 3. Type plans
 4. On board plans

- 2-58. Plans that illustrate the general arrangement of equipment, systems, or components that are not necessarily subject to strict compliance as to details are what type of plans?
1. Type
 2. Working
 3. Contract
 4. Contract guidance
- 2-59. Which of the following is NOT a necessary practice in the handling and stowage of blueprints?
1. Keep prints out of strong sunlight
 2. Keep prints stowed in their proper place
 3. Keep prints out of strong, magnetic fields
 4. Keep prints folded properly
- 2-60. Which type of diagram shows the individual connections within a unit and the physical arrangement of the component?
1. Isometric wiring diagram
 2. Pictorial wiring diagram
 3. Schematic diagram
 4. Wiring (connection) diagram
- 2-61. Which type of diagram uses graphic symbols to show how a circuit functions electrically?
1. Schematic diagram
 2. Isometric wiring diagram
 3. Wiring (connection) diagram
 4. Pictorial wiring diagram
- 2-62. Which type of diagram shows how each conductor is connected within the various connection boxes of an electrical circuit or system?
1. Elementary wiring diagram
 2. Schematic diagram
 3. Isometric wiring diagram
 4. Single-line diagram
- 2-63. A cable classified as semivital has what color tag?
1. Gray
 2. Yellow
 3. Red
 4. Blue
- 2-64. In the new electrical cable numbering system in use aboard navy ships, what letter designation is used for ship's service lighting?
1. C
 2. D
 3. L
 4. N
- 2-65. Aboard ship, a cable designated 2-FB-411B3 has what voltage?
1. 120
 2. 220
 3. 350
 4. 450
- 2-66. What is the significance of the number 2 in parentheses in a cable designated (1-132-1)-3E-4P-A(2)?
1. Second deck of a power main
 2. Second deck of the ship
 3. Port side of the ship
 4. 220-volt cable
- 2-67. What does the C in the cable designation 4SGC-2N-4S indicate?
1. Type of service, communications
 2. Third switchboard
 3. Cable
 4. Third generator supplying the switchboard
- 2-68. Electrical prints are usually more difficult to read than electronic prints.
1. True
 2. False

- 2-69. For a complete understanding of synchros, gyros, analog computing elements, and accelerometers, what type of drawing should you use?
1. Electromechanical
 2. Interconnection
 3. Mechanical
 4. Electrical
- 2-70. What type of diagrams are used in the operation and maintenance of digital computers?
1. Schematic diagrams
 2. Logic diagrams
 3. Isometric wiring diagrams
 4. Block diagrams
- 2-71. Which of the following diagrams uses geometric figures to represent major components of a piece of equipment or system?
1. Single-line diagrams
 2. Schematic diagrams
 3. Block diagrams
 4. Isometric wiring diagrams
- 2-72. Similar unit and other shipboard machinery and equipment that comprise a group is assigned a separate series of consecutive numbers beginning with 1. Which of the following is the correct way to start and end the numbering?
1. Port to starboard, aft to forward
 2. Forward to aft, starboard to port
 3. Forward to aft, port to starboard
 4. Aft port, forward starboard
- 2-73. Electrical distribution panels and control panels are given identification numbers made up of three numbers separated by hyphens. What does the first number indicate?
1. Longitudinal location
 2. Transverse location
 3. Port location
 4. Vertical level unit is normally accessible
- 2-74. Main switchboard or switchgear groups supplied power directly from ship's service generators have which of the following designations?
1. 1S
 2. 1A
 3. 2K
 4. 2E

ASSIGNMENT 3

Textbook Assignment: "Maintenance," chapter 4, pages 4-1 through 4-22.

- 3-1. What diagrams are most often used by IC Electricians?
1. Block diagrams
 2. Electronic and electrical schematics
 3. Mechanical drawings
 4. Wiring diagrams
- 3-2. Block diagrams and signal flow charts are least useful for which of the following functions?
1. To describe functions of IC equipment
 2. To help personnel understand how IC systems work
 3. To show personnel how to maintain IC equipment
 4. To show the relationship of one partial schematic to another
- 3-3. The SIMM, through use of symbology, blocks, and color shading, is a new information display technique that eliminates the requirements for a well-informed technician.
1. True
 2. False
- 3-4. The index of the SIMM is organized on what basis?
1. According to cabinet nomenclature and circuit elements
 2. According to functional entity
 3. According to main assemblies and contained assemblies
 4. According to circuit elements only
- 3-5. Which of the following is NOT a building block of the SIMM?
1. Blocked schematic
 2. Blocked text
 3. Blocked diagram
 4. Precise-access blocked diagram
- 3-6. The blue-shaded area of a blocked schematic shows the functional features of a circuit.
1. True
 2. False
- 3-7. Detailed cabling information between all assemblies is shown on which of following types of illustrations?
1. Blocked schematic
 2. Electrical/electronic schematic
 3. Mechanical drawing
 4. Precise-access blocked diagram
- 3-8. Where are the turn-on and checkout procedures located on the operating procedures page?
1. On one horizontal line across the top of the page
 2. Down the left-hand side of the page
 3. Down the right-hand side of the page
 4. In the lower right-hand corner
- 3-9. On a maintenance dependency chart, what does a solid black rectangle with white lettering represent?
1. A front panel indicator or event recognizable from outside of the cabinet
 2. An event recognizable inside of the cabinet
 3. An external test point
 4. An internal test point

- 3-10. Subassemblies, such as synchro motors, that frequently are identified by nonreadily translatable military-type numbers also include what other information?
1. Navy standard stock numbers
 2. Suitable substitute assembly numbers
 3. Allowance parts list number of the equipment
 4. Sufficient meaningful data for ordering purposes
- 3-11. The technique of isolating a fault is based upon a positive approach, which is an analysis of circuitry to verify that things that should have happened did happen.
1. True
 2. False
- 3-12. An action or availability of a signal at a point in a circuit is the definition of what term?
1. Circuit element
 2. Functional entity
 3. Event
 4. Dependency marker
- 3-13. An individual piece or part for which no further breakdown can be made insofar as fault isolation is concerned is the definition of what term?
1. Event
 2. Functional entity
 3. Circuit element
 4. Functional marker
- 3-14. For each major circuit, there is a corresponding MDC consistent with which of the following diagrams?
1. Precise-access blocked diagrams
 2. Electronic schematics
 3. Electrical schematics
 4. Blueprints
- 3-15. Equipment and assembly halftones and line drawings are overlaid with a grid, on which coordinates are placed to assist in parts location. What color is the grid?
1. Yellow
 2. Green
 3. Red
 4. Blue
- 3-16. The keyed text method of presentation is used with all EXCEPT which of the following diagrams?
1. Schematic diagram
 2. Precise-access blocked diagram
 3. Wiring diagram
 4. Overall block diagram
- 3-17. What is the name given to wiring that interconnects subassemblies in IC equipment cabinets?
1. Chassis wiring
 2. Cabinet wiring
 3. Cable wiring
 4. Harness wiring
- 3-18. Which of the following is the first step of troubleshooting chassis wiring?
1. Smell the components
 2. Visually inspect the wiring harness from terminal to terminal
 3. Conduct continuity tests
 4. Replace the circuit cards
- 3-19. What is the best way to repair an installed wiring harness that contains damaged wires?
1. Remove the old harness completely, pull the damaged wires, and replace them one at a time, form fitting each replacement wire as it is installed
 2. Fabricate another harness to replace it, using a plywood jig
 3. Remove the damaged wires one at a time and replace each with a new straight wire
 4. Install a new harness alongside the old one

- 3-20. You have replaced wires in a chassis wiring harness. When hand pressure is applied, the replacement wire between cable clamps should sag by what amount?
1. 1 in.
 2. 3/4 in.
 3. 1/2 in.
 4. 1/4 in.
- 3-21. What is the most reliable method for locating faults in chassis wiring?
1. Trial and error
 2. Substitution of parts
 3. Signal tracing
 4. Ground checking
- 3-22. Measures taken to achieve maximum efficiency, ensure continuity of service, and lengthen useful life of equipment or systems are known as
1. general repair
 2. major repair
 3. corrective maintenance
 4. preventive maintenance
- 3-23. Locating and correcting troubles on malfunctioning systems or equipment is referred to as
1. preventive maintenance
 2. corrective maintenance
 3. major repair
 4. general repair
- 3-24. Equipment inspections fall into what total number of categories?
1. One
 2. Two
 3. Three
 4. Four
- 3-25. Which of the following items enables the technician to make an intelligent evaluation of the operating capabilities and efficiency of equipment?
1. Manufacturer's instruction book
 2. Maintenance requirement card
 3. Isometric diagram
 4. Block diagram
- 3-26. Which of the following methods of checking a discrepancy may disclose frayed or broken wiring?
1. Operational check
 2. Performance test
 3. Equipment light-off
 4. Visual in-place inspection
- 3-27. The steps through which a technician gains information about a casualty, isolates and repairs the faulty component, and clearly understands the reason for the malfunction is known as
1. troubleshooting
 2. corrective maintenance
 3. preventive maintenance
 4. system analyzing
- 3-28. Before reinstalling a piece of equipment, the senior IC Electrician should make sure which of the following operations is/are carried out?
1. Visual inspection
 2. Operational check
 3. Performance test
 4. All of the above
- 3-29. To avoid damaging a voltmeter when testing a circuit of unknown voltage, what should you do?
1. Set the voltmeter on the highest scale first and work to a lower scale
 2. Set the voltmeter on the lowest scale first and work to a higher scale
 3. Check the manufacturers' technical manuals for proper voltage levels
 4. Ensure the meter is set to read resistance and not voltage

- 3-30. If the internal resistance of the voltmeter and multiplier is approximately the same in value to the resistance of the circuit under test, what will be the indication when the meter is removed?
1. A lower voltage than the actual voltage present
 2. A higher voltage than the actual voltage present
 3. The voltage will be the same as the actual voltage
 4. The voltage will vary in the circuit
- 3-31. Which of the following is a disadvantage of taking voltage measurements?
1. It is time consuming
 2. It is less accurate
 3. It requires working on an energized circuit
 4. There is no way of knowing the correct voltage
- 3-32. At which of the following times should you discharge filter capacitors with a shorting probe?
1. Before resistance checks
 2. Before capacitor leads are disconnected
 3. Both 1 and 2 above
 4. Before voltage checks
- 3-33. The waveforms shown in maintenance books should match exactly the actual waveform displayed on an oscilloscope?
1. True
 2. False
- 3-34. Equipment characteristics and usage can cause distortion of an observed waveform. Which of the following situations can cause this distortion?
1. The leads of the test oscilloscope may not be placed in the same manner as those preparing the reference waveform
 2. A type of test oscilloscope having different values of input impedance, sweep duration, or frequency response may have been used
 3. The vertical or horizontal amplitudes of the reference and test amplitudes of the reference and test patterns may not be proportional
 4. Each of the above
- 3-35. Which of the following is NOT an advantage of using a transistor amplifier over a vacuum-tube amplifier?
1. Transistors have longer life and less power consumption
 2. Transistors are more efficient in using dc power and operating at low voltages
 3. Transistors lack microphonics signals and have little or no ac hum
 4. Transistors can dissipate more heat
- 3-36. The most desirable method of matching source impedance to input impedance is by what type of coupling?
1. Resistor-capacitor
 2. Transformer
 3. Direct
 4. Resistor

3-37. The most common emitter configuration may be used to match a high source resistance by the addition of what component in the base lead?

1. Series capacitor
2. Parallel capacitor
3. Series resistor
4. Parallel resistor

3-38. If a speaker is connected directly to the output of a transistor, there is little or no audio gain due to which of the following factors?

1. Characteristics of the transistor
2. High impedance of the speaker
3. Low impedance of the speaker
4. Circuit configuration

3-39. What type of connection should you use to get a highly reliable 4-speaker system?

1. Series connection of two sets of speakers in parallel
2. Series strip connection
3. Parallel speakers in series with another speaker
4. Parallel connection of two sets of speakers in series

3-40. In a constant-voltage speaker system, the distribution of audio power is affected only slightly or not at all by which of the following factors?

1. Addition to the system
2. Changes to the system
3. Unmatched impedance
4. Each of the above

IN ANSWERING QUESTION 3-41, REFER TO FIGURE 4-19 OF THE TEXT.

3-41. What is the output voltage of the speaker system shown?

1. 120.0 V
2. 90.0 V
3. 70.0 V
4. 50.0 V

3-42. You have a transformer whose 8-ohm secondary is connected to an 8-ohm speaker. What should be the impedance of the primary to deliver 50 watts from a 70-volt line?

1. 50 ohms
2. 100 ohms
3. 150 ohms
4. 200 ohms

3-43. What is an electronic module?

1. A piece of electronic equipment consisting of replaceable assemblies
2. An assembly constructed of standardized electronic components
3. A package of wired electronic components capable of functioning as an assembly when used with other assemblies
4. A package of standardized electronic units assembled to function as a self-contained system

3-44. What is one of the most common quick part identification methods developed by commercial manufacturers?

1. Number points of interest on the schematic, and a guide provided to locate the numbered points
2. A grid imposed over a drawing of the board and a corresponding table that lists the part location
3. Parts labeled directly on the schematic
4. Each of the above

3-45. When you are circuit tracing a translucent printed-circuit board, which of the following methods will make the job easier?

1. Use a mirror to observe the opposite side
2. Use an ohmmeter for point to point tracing
3. Use a lighted bulb under the board
4. Use a grid over the printed circuit portion

- 3-46. The shop supervisor should ensure that personnel using test equipment on printed-circuit boards employ which of the following safe work practices?
1. Observe polarities in measuring circuit resistance
 2. Start signal application at a sufficiently low level
 3. Secure all components before turning the power on
 4. Each of the above
- 3-47. When you are trying to find an acceptable substitute for a specific relay, which of the following specifications should be considered?
1. Coil resistance only
 2. Current rating only
 3. Voltage rating only
 4. Voltage rating, current rating, coil resistance, contact type, and arrangement of contacts
- 3-48. When you are inspecting a de-energized IC switchboard, in addition to a close visual inspection, what other check(s) should you perform?
1. Shake all electrical connections to see that they are tight
 2. Shake all mechanical parts to see that they work properly
 3. Make sure the supports of bus work will keep bus bars from touching grounded parts
 4. All of the above
- 3-49. By virtue of the rating, an IC Electrician is authorized to repair switchboard instruments.
1. True
 2. False
- 3-50. In general, why are protective circuits NOT tested under actual operating conditions?
1. Too many different types of circuits are involved
 2. Equipment damage is likely to result
 3. Repair parts are not available
 4. The possibility of human error is too high
- 3-51. Before You start repairing an energized switchboard, permission to do so must come from your commanding officer.
1. True
 2. False
- 3-52. Which of the following practices will help prevent damage to a current transformer, but NOT a potential transformer?
1. Short circuiting the secondary of the transformer
 2. Short circuiting the primary of the transformer
 3. Opening the secondary of the transformer while the current is flowing through the primary
 4. Each of the above